

Academy at Anderson Creek 1112 - 173 Scholar Drive, Spring Lake, 28390  
 Harnett County  
 Created: 4/5/2021

House Plan: Mixon III  
 Elevation: A  
 Stone/Brick Option: Option #1 see MSS  
 Foundation: Crawl  
 Foundation Finish: 3 Sides Parged  
 Garage Hand: Right  
 Garage: 2 Car Front  
 Garage Door: (2) 8x8  
 Front Porch: Concrete  
 Roof: Truss  
 Siding: Fiber Cement  
 Ceiling Height 1st Floor: 9'  
 Ceiling Height 2nd Floor: 9'  
 Door Frame Height 1st Floor: 83"  
 Door Frame Height 2nd Floor: 83"  
 Windows 1st Floor: 6/0 Front only, 5/0 side&rear  
 Windows 2nd Floor: 5/0

**OPTIONS**  
 Screen Porch  
 Study in Lieu of Bedroom #5  
 Rec Room  
 Trey Ceiling in Master Bedroom

Total Heated SQ FT: 2981  
 Total Unheated SQ FT: 640  
 Total SQ FT: 3621

Bedrooms: 4+ Rec Room + Study  
 Full Bathrooms: 3  
 Half Bathrooms: 0



THIS PLAN CONFORMS TO THE 2018 EDITION OF THE I.R.C. / NORTH CAROLINA RESIDENTIAL CODE.  
**FRONT ELEVATION "A"**  
 SCALE: ----- 1/8" = 1'-0"  
 STONE OPTION #1

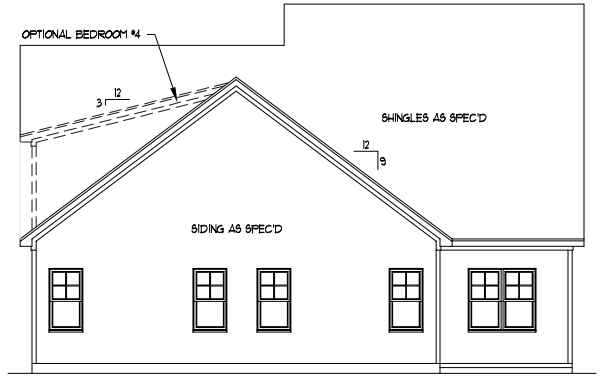
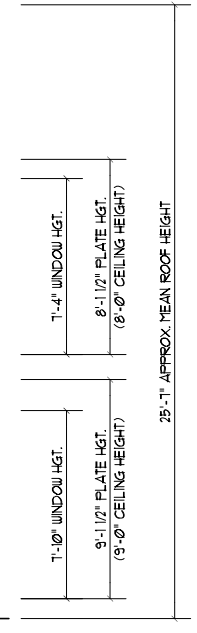

**REAR ELEVATION**  
 SCALE: ----- 1/16" = 1'-0"  
 WITH BEDROOM #4 OPTION

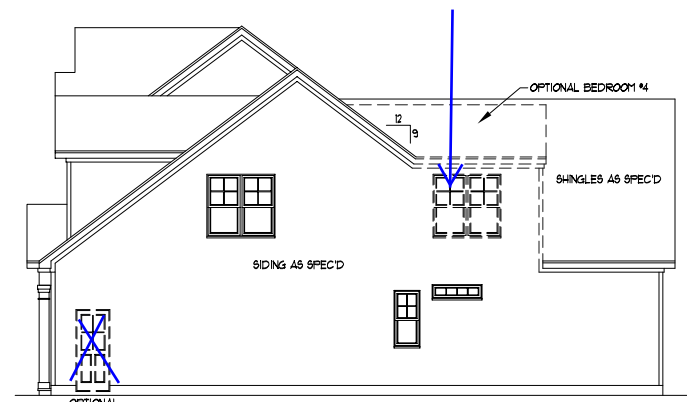

**RIGHT SIDE ELEVATION**  
 SCALE: ----- 1/16" = 1'-0"  
 WITH BEDROOM #4 OPTION

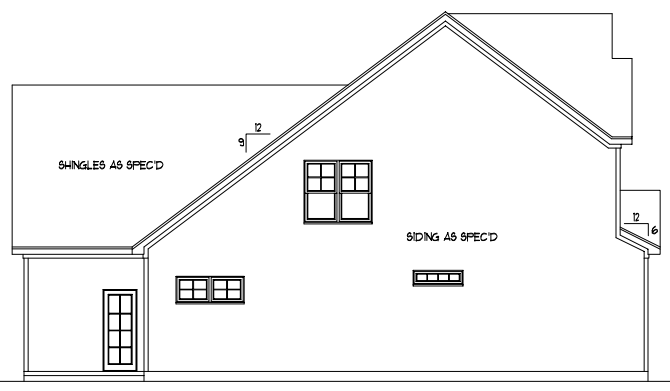

**LEFT SIDE ELEVATION**  
 SCALE: ----- 1/16" = 1'-0"

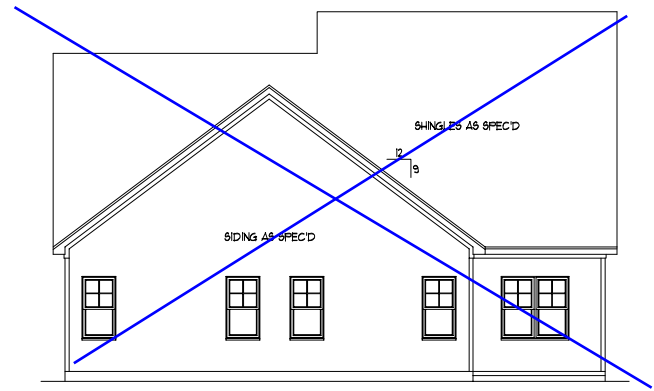

**REAR ELEVATION**  
 SCALE: ----- 1/16" = 1'-0"

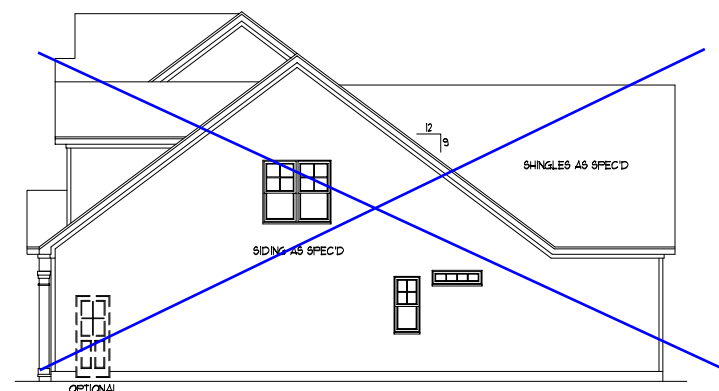

**RIGHT SIDE ELEVATION**  
 SCALE: ----- 1/16" = 1'-0"

Include Windows

**DYNAMIC DESIGN GROUP, INC**  
 David D Grorud  
 (919) 601-1406  
 DynamicDesignGroup@gmail.com

The drawings and specifications (plans) contained on these pages are the property of Dynamic Design Group and are offered to the named client or contractor for a conditional one time use. The conditional use is limited to the lot and subdivision specified herein, and only for said location. COPYRIGHT 2021  
 Contractor shall verify all conditions and dimensions prior to construction. Any error or omissions shall be reported to Dynamic Design Group for corrections or justification. Once construction has commenced, the contractor shall assume all responsibility. Dimensions govern over scale, code governs over dimensions.

CAPITOL  
 PROJECT FOR: CITY HOMES  
 LOCATION: MULTI  
 LOT: MULTI  
 SUBDIVISION: MULTI  
 COUNTY: MULTI

**MIXON III**  
 PLAN NAME  
**B-2287-45GR**  
 PLAN I.D.  
**1-28-21**  
 DATE

**A-1A**  
 SHEET

The drawings and specifications (plans) contained on these pages are the property of Dynamic Design Group and are offered to the named client or contractor for a conditional one time use. The conditional use is limited to the lot and subdivision specified herein, and only for said location. COPYRIGHT 2021  
 Contractor shall verify all conditions and dimensions prior to construction. Any error or omissions shall be reported to Dynamic Design Group for corrections or justification. Once construction has commenced, the contractor shall assume all responsibility. Dimensions govern over scale, code governs over dimensions.

CAPITOL  
 PROJECT FOR: CITY HOMES  
 LOCATION: MULTI  
 LOT: MULTI  
 SUBDIVISION: MULTI  
 COUNTY: MULTI

**MIXON III**  
 PLAN NAME  
**B-2287-45GR** 1-28-21 DATE  
 PLAN I.D.

**A-2A**  
 SHEET

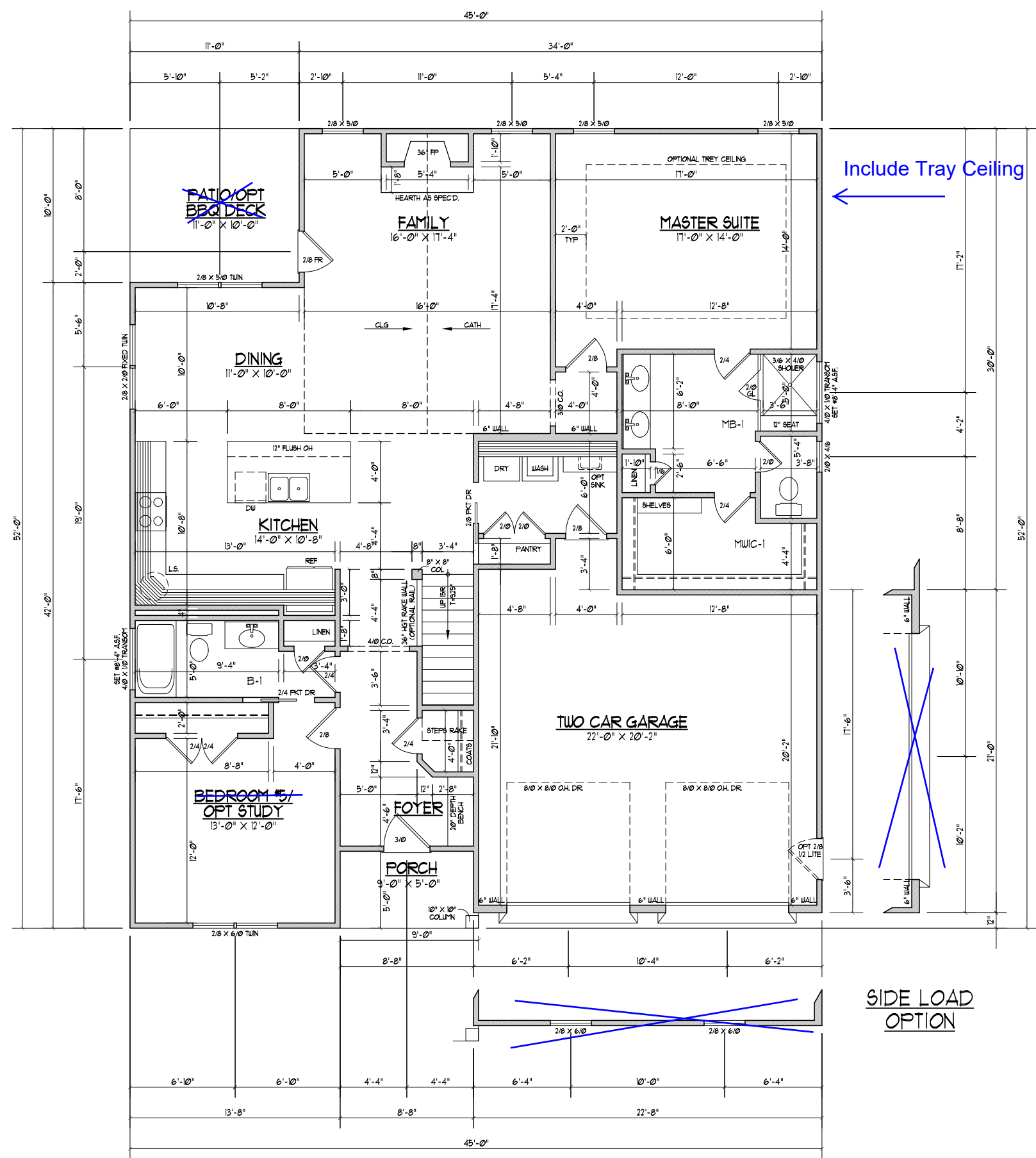

Include Screened Porch →

← Include Tray Ceiling

Study in Lieu of Bedroom #5 →

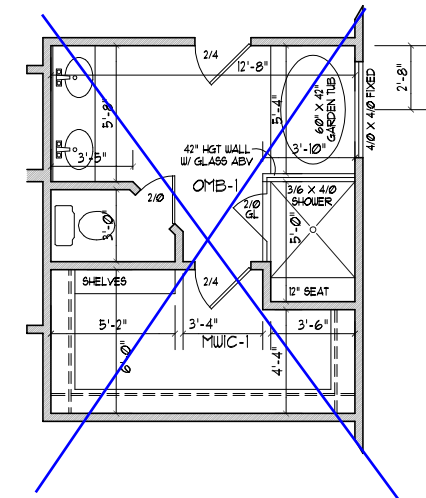

MASTER BATH OPTION

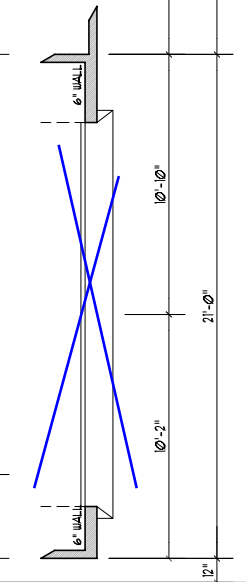

SIDE LOAD OPTION

ELEVATION "A" & "B"  
 FIRST FLOOR PLAN  
 SCALE: ----- 1/8" = 1'-0"

1611 HEATED SQ. FT.  
 486 SQ. FT. GARAGE  
 44 SQ. FT. COVERED PORCH  
 110 SQ. FT. PATIO / OPT BBQ DECK

- NOTES:
- 9'-0" CLG. HGT. (9' - 1 1/2" FLT. HGT.) UNLESS OTHERWISE NOTED.
  - ALL WALLS DRAIN AT 4" WIDTHS
  - SET WINDOWS AT 1'-10" A.S.F. UNLESS OTHERWISE NOTED.
  - DIMENSIONS ARE TO FRAMING UNLESS OTHERWISE NOTED.
  - CONSULT WINDOW MANUFACTURER'S SPECS. FOR EGRESS REQUIREMENTS, PRESSURE RATINGS, & ROUGH OPNG'S.

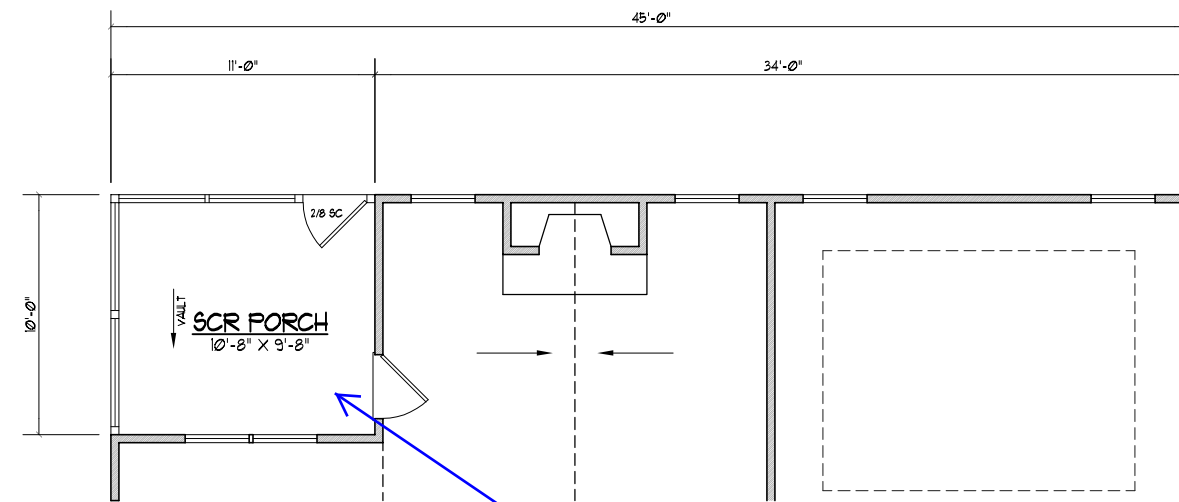

**Include**  
**SCREEN PORCH**  
 SCALE: ----- 1/8" = 1'-0"  
 110 SQ. FT. SCREEN PORCH

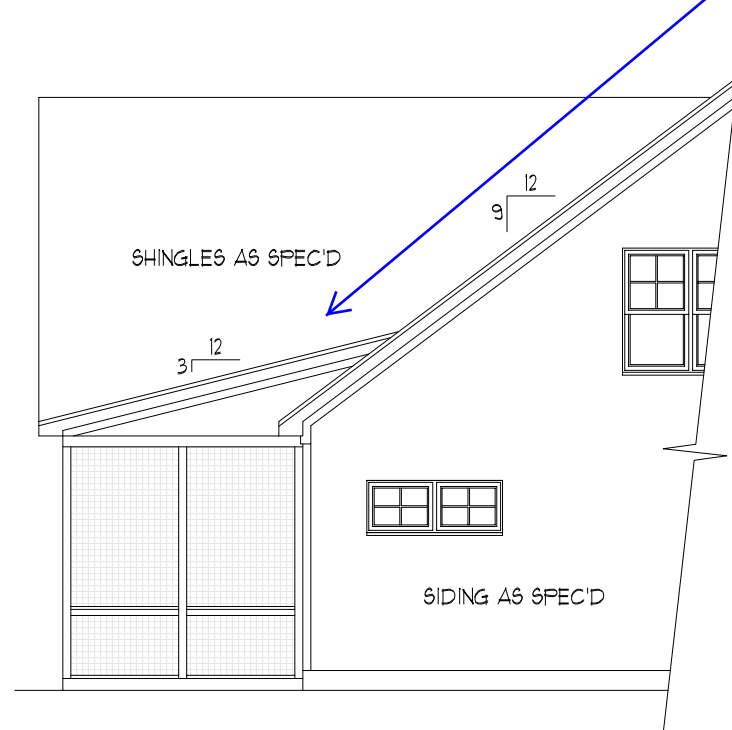

**LEFT SIDE**

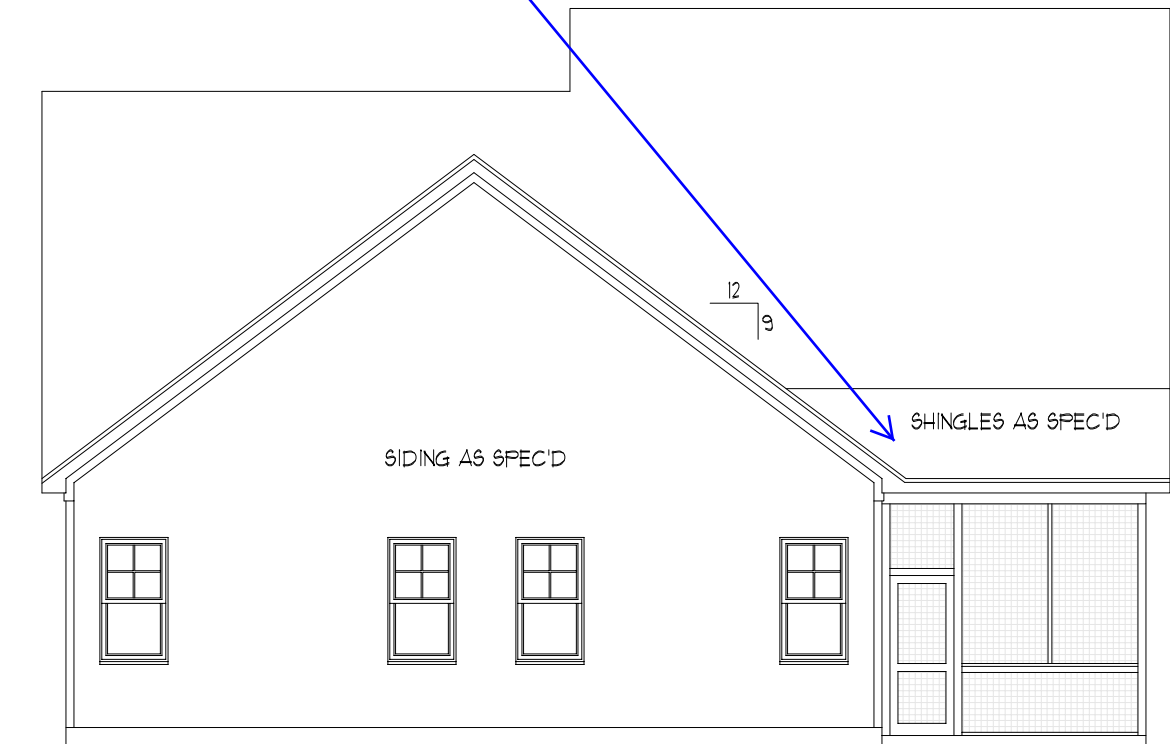

**REAR ELEVATION**  
 SCALE: ----- 1/8" = 1'-0"

~~OPTIONAL~~  
**SCREEN PORCH**

**DYNAMIC DESIGN GROUP, INC**  
 David D Grorud  
 (919) 601-1406  
 DynamicDesignGroup@gmail.com

The drawings and specifications (plans) contained on these pages are the property of Dynamic Design Group and are offered to the named client or contractor for a conditional one time use. The conditional use is limited to the lot and subdivision specified herein, and only for said location. COPYRIGHT 2021  
 Contractor shall verify all conditions and dimensions prior to construction. Any error or omissions shall be reported to Dynamic Design Group for corrections or justification. Once construction has commenced, the contractor shall assume all responsibility. Dimensions govern over scale, code governs over dimensions.

CAPITOL  
 PROJECT FOR: CITY HOMES  
 LOCATION: MULTI  
 LOT: MULTI  
 SUBDIVISION: MULTI  
 COUNTY: MULTI

**MIXON III**  
 PLAN NAME  
**B-2287-45GR** 1-28-21  
 PLAN I.D. DATE

**A-2** SCREEN PORCH OPTION  
 SHEET

The drawings and specifications (plans) contained on these pages are the property of Dynamic Design Group and are offered to the named client or contractor for a conditional one time use. The conditional use is limited to the lot and subdivision specified herein, and only for said location. COPYRIGHT 2021  
 Contractor shall verify all conditions and dimensions prior to construction. Any error or omissions shall be reported to Dynamic Design Group for corrections or justification. Once construction has commenced, the contractor shall assume all responsibility. Dimensions govern over scale, code governs over dimensions.

CAPITOL  
 PROJECT FOR: CITY HOMES  
 LOCATION: MULTI  
 LOT: MULTI  
 SUBDIVISION: MULTI  
 COUNTY: MULTI

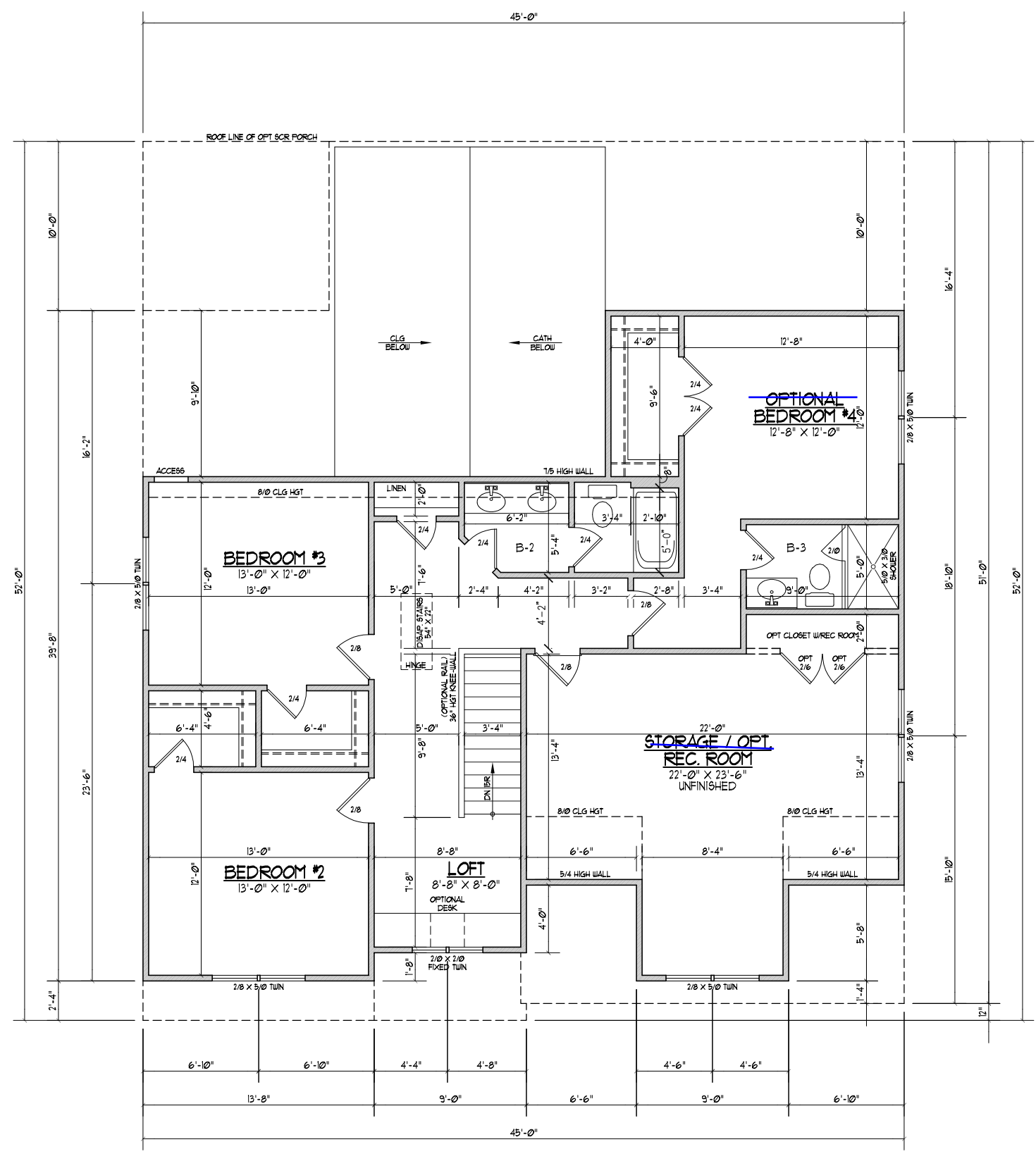

← Include Bedroom #4

← Include Rec Room and Closet

**ELEVATION "A"**  
**SECOND FLOOR PLAN**  
**W/ BEDROOM #4 / BATH OPTION**  
 SCALE ----- 1/8"=1'-0"

992 HEATED SQ. FT.  
 378 UNFIN. STORAGE SQ. FT.

- NOTES:
- 1) 8'-0" CLG. HGT. (8' - 1 1/2" FLT. HGT.) UNLESS OTHERWISE NOTED.
  - 2) ALL WALLS DRAWN AT 4" WIDTHS UNLESS OTHERWISE NOTED.
  - 3) SET WINDOWS AT 1'-4" A.S.F. UNLESS OTHERWISE NOTED.
  - 4) DIMENSIONS ARE TO FRAMING UNLESS OTHERWISE NOTED.
  - 5) CONSULT WINDOW MANUFACTURER'S SPECS. FOR EGRESS REQUIREMENTS, PRESSURE RATINGS, & ROUGH OPENINGS.

**MIXON III**  
 PLAN NAME  
**B-2287-45GR** 1-28-21  
 PLAN I.D. DATE

**A-3A**  
 SHEET

The drawings and specifications (plans) contained on these pages are the property of Dynamic Design Group and are offered to the named client or contractor for a conditional one time use. The conditional use is limited to the lot and subdivision specified herein, and only for said location. COPYRIGHT 2021  
 Contractor shall verify all conditions and dimensions prior to construction. Any error or omissions shall be reported to Dynamic Design Group for corrections or justification. Once construction has commenced, the contractor shall assume all responsibility. Dimensions govern over scale, code governs over dimensions.

CAPITOL  
 PROJECT FOR: CITY HOMES  
 LOCATION: MULTI  
 LOT: MULTI  
 SUBDIVISION: MULTI  
 COUNTY: MULTI

**MIXON III**  
 PLAN NAME  
**B-2287-45GR** 1-28-21  
 PLAN I.D. DATE

**E-1**  
 SHEET

ELECTRICAL SYMBOLS	
	CEILING MOUNTED LIGHT FIXTURE
	DIRECTIONAL EYEBALL LIGHT FIXTURE
	RECESSED LIGHT FIXTURE
	MINI RECESSED LIGHT FIXTURE
	WALL MOUNTED LIGHT FIXTURE
	FLUORESCENT LIGHT
	1/2 -- 1 BULB @ 2'
	2/2 -- 2 BULB @ 2'
	1/4 -- 1 BULB @ 4'
	2/4 -- 2 BULB @ 4'
	4/4 -- 4 BULB @ 4'
	HANGING LIGHT FIXTURE
	TELEPHONE JACK
	CABLE JACK
	KEYLESS LIGHT FIXTURE
	CEILING FAN WITH LIGHT FIXTURE
	UNDER CABINET LIGHT
	EXHAUST FAN
	RECESSED SHOWER LIGHT
	EXTERIOR FLOOD LIGHT
	SMOKE DETECTOR
	CARBON MONOXIDE DETECTOR
	DOOR CHIMES
	METERBOX
	A/C UNIT
	110 OUTLET
	220V OUTLET
	SINGLE SWITCH
	3-WAY SWITCH
	4-WAY SWITCH
	OUTDOOR OUTLET
	GFI

Include Screened Porch

Study in Lieu of Bedroom #5

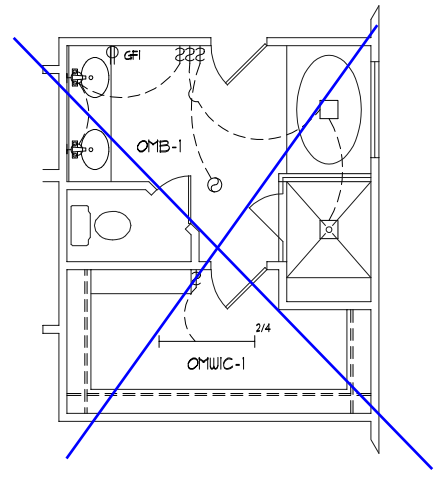
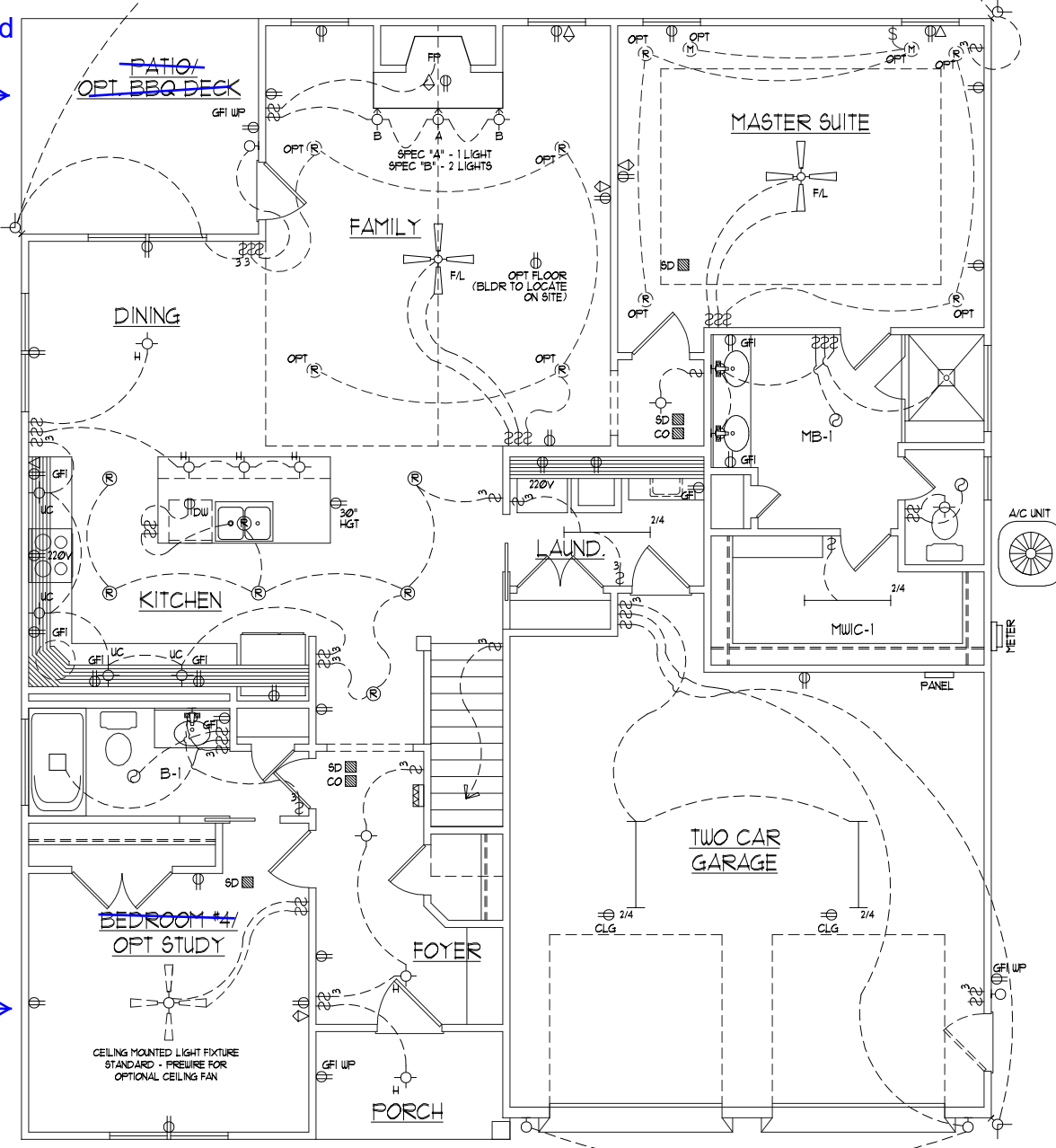

MASTER BATH OPTION

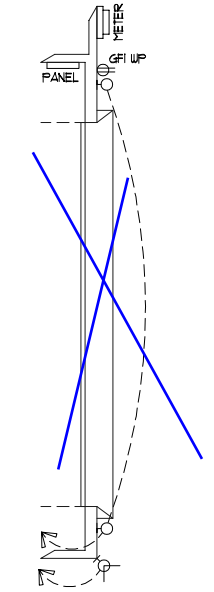

OPTIONAL SIDE LOAD

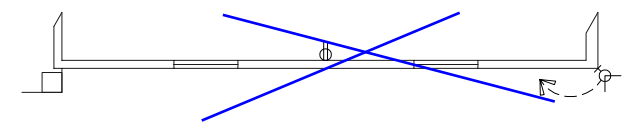

OPTIONAL ELECTRICAL ITEMS	
WITH ALL LIGHTS LISTED RESPECTIVE SWITCHES ARE ASSUMED	
RECESSED LIGHTS	
FLUORESCENT LIGHT IN LIEU OF RECESSED CANS @ KITCHEN ONLY	
CEILING FANS IN LIEU OF FLUSH MOUNT	
FLOODLIGHTS	
HANGING LIGHTS @ KITCHEN	
UNDER CABINET LIGHTS	
EXTERIOR LIGHTS AT GARAGE DOOR	

FIRST FLOOR ELECTRICAL LAYOUT

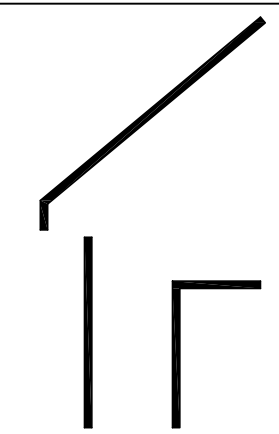

**DYNAMIC DESIGN GROUP, INC**

David D Grorud  
 (919) 601-1406  
 DynamicDesignGroup@gmail.com

The drawings and specifications (plans) contained on these pages are the property of Dynamic Design Group and are offered to the named client or contractor for a conditional one time use. The conditional use is limited to the lot and subdivision specified herein, and only for said location. COPYRIGHT 2021  
 Contractor shall verify all conditions and dimensions prior to construction. Any error or omissions shall be reported to Dynamic Design Group for corrections or justification. Once construction has commenced, the contractor shall assume all responsibility. Dimensions govern over scale, code governs over dimensions.

CAPITOL  
 PROJECT FOR: CITY HOMES  
 LOCATION: MULTI  
 LOT: MULTI  
 SUBDIVISION: MULTI  
 COUNTY: MULTI

**MIXON III**  
 PLAN NAME  
**B-2287-45GR** 1-28-21  
 PLAN I.D. DATE

**E-1** SCREEN PORCH OPTION  
 SHEET

ELECTRICAL SYMBOLS	
	CEILING MOUNTED LIGHT FIXTURE
	DIRECTIONAL EYEBALL LIGHT FIXTURE
	RECESSED LIGHT FIXTURE
	MINI RECESSED LIGHT FIXTURE
	WALL MOUNTED LIGHT FIXTURE
	FLUORESCENT LIGHT 1/2 -- 1 BULB @ 2' 2/2 -- 2 BULB @ 2' 1/4 -- 1 BULB @ 4' 2/4 -- 2 BULB @ 4' 4/4 -- 4 BULB @ 4'
	HANGING LIGHT FIXTURE
	TELEPHONE JACK
	CABLE JACK
	KEYLESS LIGHT FIXTURE
	CEILING FAN WITH LIGHT FIXTURE
	UNDER CABINET LIGHT
	EXHAUST FAN
	RECESSED SHOWER LIGHT
	EXTERIOR FLOOD LIGHT
	SMOKE DETECTOR
	CARBON MONOXIDE DETECTOR
	DOOR CHIMES
	METERBOX
	A/C UNIT
	110 OUTLET
	220 OUTLET
	SINGLE SWITCH
	3-WAY SWITCH
	4-WAY SWITCH
	OUTDOOR OUTLET
	GFI

Include Screened Porch

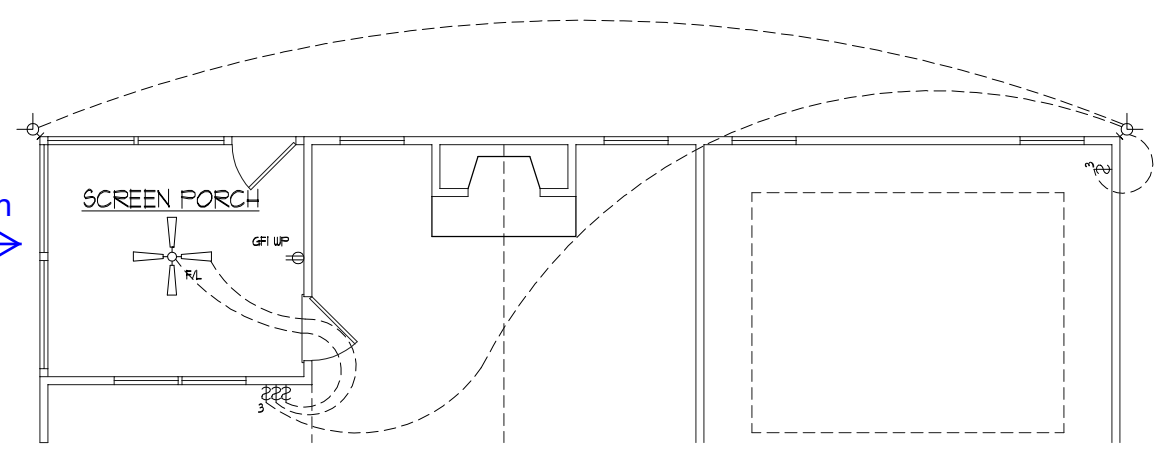

OPTIONAL SCREEN PORCH

The drawings and specifications (plans) contained on these pages are the property of Dynamic Design Group and are offered to the named client or contractor for a conditional one time use. The conditional use is limited to the lot and subdivision specified herein, and only for said location. COPYRIGHT 2021  
 Contractor shall verify all conditions and dimensions prior to construction. Any error or omissions shall be reported to Dynamic Design Group for corrections or justification. Once construction has commenced, the contractor shall assume all responsibility. Dimensions govern over scale, code governs over dimensions.

CAPITOL  
 PROJECT FOR: CITY HOMES  
 LOCATION: MULTI  
 LOT: MULTI  
 SUBDIVISION: MULTI  
 COUNTY: MULTI

**MIXON III**  
 PLAN NAME  
**B-2287-45GR** 1-28-21  
 PLAN I.D. DATE

**E-2**  
 SHEET

ELECTRICAL SYMBOLS	
	CEILING MOUNTED LIGHT FIXTURE
	DIRECTIONAL EYEBALL LIGHT FIXTURE
	RECESSED LIGHT FIXTURE
	MINI RECESSED LIGHT FIXTURE
	WALL MOUNTED LIGHT FIXTURE
	FLUORESCENT LIGHT
	1/2 -- 1 BULB @ 2'
	2/2 -- 2 BULB @ 2'
	1/4 -- 1 BULB @ 4'
	2/4 -- 2 BULB @ 4'
	4/4 -- 4 BULB @ 4'
	HANGING LIGHT FIXTURE
	TELEPHONE JACK
	CABLE JACK
	KEYLESS LIGHT FIXTURE
	CEILING FAN WITH LIGHT FIXTURE
	UNDER CABINET LIGHT
	EXHAUST FAN
	RECESSED SHOWER LIGHT
	EXTERIOR FLOOD LIGHT
	SMOKE DETECTOR
	CARBON MONOXIDE DETECTOR
	DOOR CHIMES
	METERBOX
	A/C UNIT
	110 OUTLET
	220 OUTLET
	SINGLE SWITCH
	3-WAY SWITCH
	4-WAY SWITCH
	OUTDOOR OUTLET
	GFI

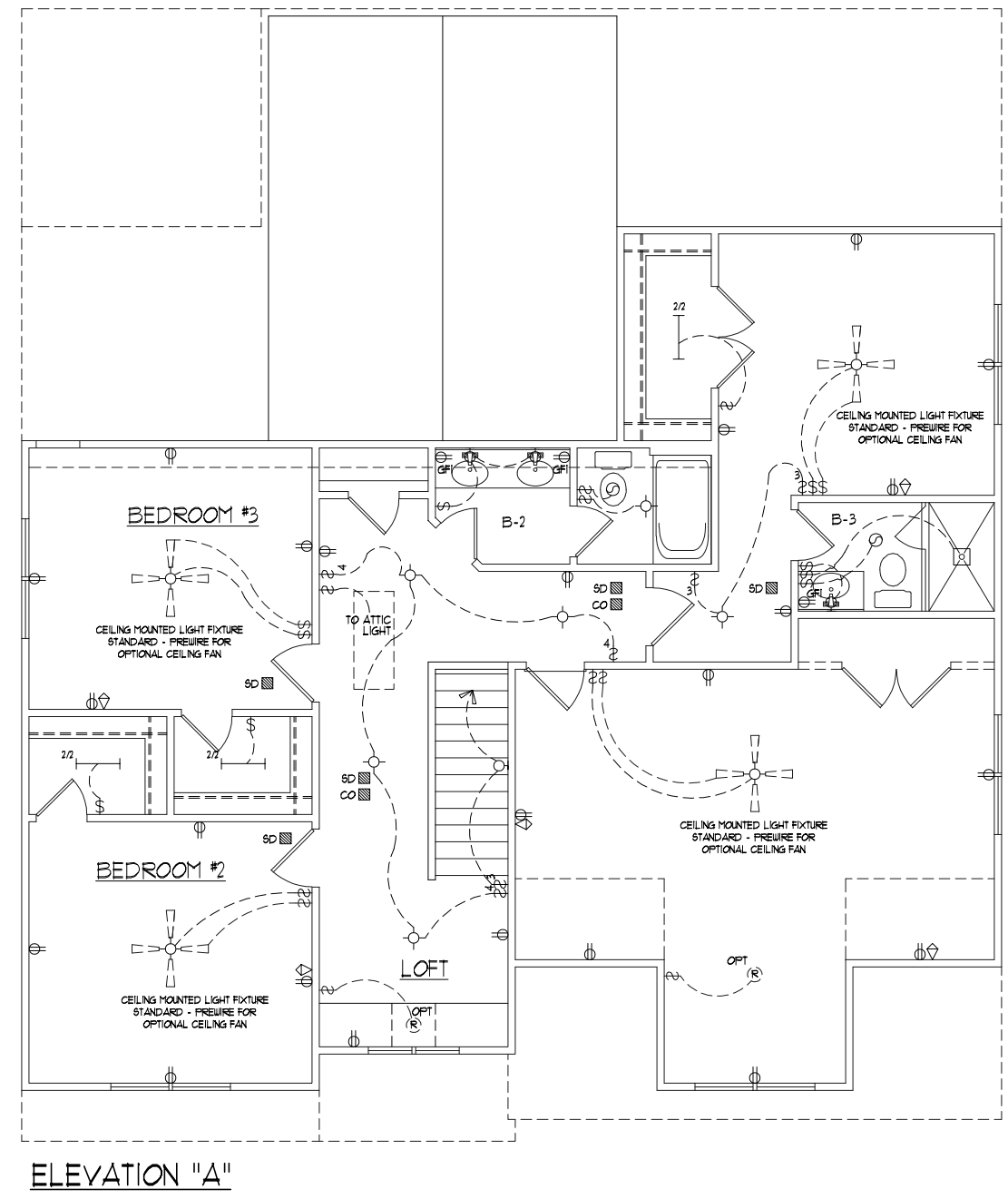

← Include Bedroom #4

← Include Rec Room and Closet

SECOND FLOOR  
 ELECTRICAL LAYOUT  
 W/ BEDROOM #4 / BATH OPTION

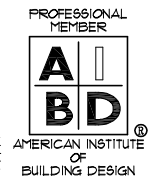
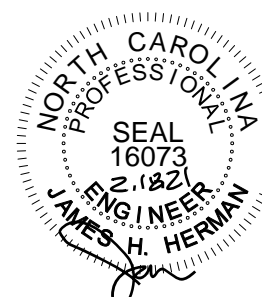

Include Screened Porch

4x4 P.T. POST ON 16"x16"x8" CONCRETE FTG. (TYP). BRACE POSTS PER APPENDIX M.

**FOUNDATION STRUCTURAL NOTES**  
NC (2018 NCRS); Wind: 115-120 mph

1. (3) 2x10 SYP#2 OR SPF#2 GIRDER, TYPICAL UNO.
2. CONCRETE BLOCK PIER SIZE SHALL BE:
 

SIZE	HOLLOW	SOLID
8x16	UP TO 32"	UP TO 5'-0"
12x16	UP TO 48"	UP TO 9'-0"
16x16	UP TO 64"	UP TO 12'-0"
24x24	UP TO 64"	UP TO 46"

 WITH 30" x 30" x 10" CONCRETE FOOTING, UNO.
3. WALL FOOTING AS FOLLOWS
 

DEPTH:	8" - UP TO 2 STORY 10" - 3 STORY
WIDTH:	16" - UP TO 2 STORY 20" - 3 STORY
SIDING:	16" - 1 STORY 20" - 2 STORY 24" - 3 STORY
BRICK:	
- FOR FOUNDATION WALL HEIGHT AND BACKFILL REQUIREMENTS, REFER TO CODE TABLE R404.1.1 (1 THRU 4) NOTE: ASSUMED SOIL BEARING CAPACITY = 2000 PSF. CONTRACTOR MUST VERIFY SITE CONDITIONS AND CONTACT SOILS ENGINEER IF MARGINAL OR UNSTABLE SOILS ARE ENCOUNTERED.
4. (4) 2x10 SPF #2 OR SYP #2 GIRDER
5. (2) 1.75x4.25 LVL OR LSL GIRDER
6. (3) 1.75x4.25 LVL OR LSL GIRDER
7. ■ DESIGNATES A SIGNIFICANT POINT LOAD TO HAVE SOLID BLOCKING TO PIER. SOLID BLOCK ALL BEAM BEARING POINTS NOTED TO HAVE THREE OR MORE STUDS TO FND, TYPICAL.
8. ABBREVIATIONS:
  - "S.J." = SINGLE JOIST
  - "D.J." = DOUBLE JOIST
  - "T.J." = TRIPLE JOIST

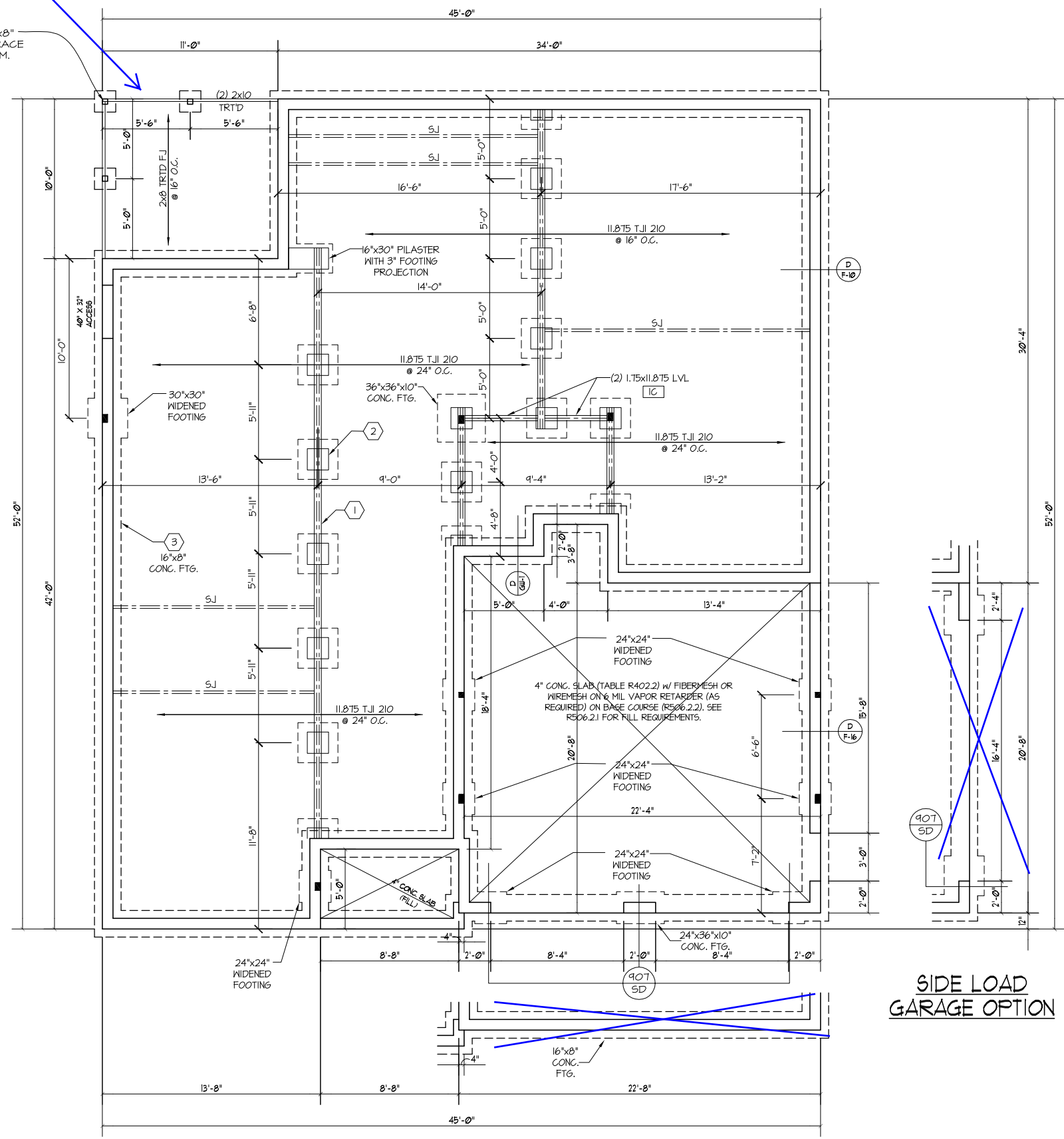

STRUCTURAL DESIGN BY:  
SOUTHERN ENGINEERS, P.A.  
3716 BENSON DR., RALEIGH, NC 27604  
LICENSE: C-1287, PHONE: 919-878-1611  
PROJECT # 21-2282 GR

- Engineers seal applies only to structural components on this document. Seal does not include construction means, methods, techniques, sequences, procedures or safety precautions.
- Any deviations or discrepancies on plans are to be brought to the immediate attention of Southern Engineers. Failure to do so will void Southern Engineer's liability.
- Seal is valid for a project permitted within one year from date of seal.
- Use of these plans constitutes approval of terms & conditions as defined in the customer agreement.

REFER TO "SD" SHEET(S) FOR STANDARD DETAILS, BRACING DETAILS AND STRUCTURAL NOTES.

LVL SCHEDULE	
1C	(2) 1.75x11.875 - 10'

**WOOD "I" JOISTS**

- (SHALL BE ONE OF THE FOLLOWING):
- TJI 210 BY I-LEVEL
  - LPI 20 PLUS BY LP
  - BCI 5000s 1.8 BY BC
- ALL WOOD "I" JOISTS SHALL BE INSTALLED ACCORDING TO MANUFACTURER'S SPECIFICATIONS.
  - INSTALL SQUASH BLOCKS, WEB STIFFENERS, ETC. AS REQUIRED BY AND ACCORDING TO THE I-JOIST MANUFACTURER'S SPECIFICATIONS AND INSTRUCTIONS.
  - HANGERS FOR I-JOISTS ARE THE RESPONSIBILITY OF THE I-JOIST SUPPLIER.

WALL VENTED CRAWL SPACE	
REQUIRED	
1678	SQ. FT. / 150 = 9.84
	SQ. FT. OF VENTILATION

CLOSED CRAWL SPACE VENTILATION METHODS	
(SEE REFERENCED SECTIONS IN CODE BOOK FOR DETAILED INSTRUCTIONS)	
(R409.5.1) DEHUMIDIFIER	A PERMANENTLY INSTALLED DEHUMIDIFIER SHALL BE PROVIDED IN THE CRAWL SPACE WITH THE MINIMUM RATED CAPACITY OF 5 PANTS PER DAY.
(R409.5.2) SUPPLY AIR	1678 SQ. FT. / 30 = 50 CFM
(R409.5.3) HOUSE AIR	1678 SQ. FT. / 50 = 30 CFM
(R409.5.4) EXHAUST FAN	1678 SQ. FT. / 50 = 30 CFM
(R409.5.5) CONDITIONED SPACE	THE CRAWL SPACE SHALL BE DESIGNED AS A HEATED AND COOLED, CONDITIONED SPACE WITH WALL INSULATION INSTALLED AS PER THE REQUIREMENTS OF SECTION R409.5.1.

**CRAWL SPACE FOUNDATION PLAN**  
SCALE: 1/8"=1'-0"

- NOTES:
- 1) SEE SHEET D-1 FOR DETAILS.
  - 2) DIMENSIONS ARE TO EXTERIOR OF FOUNDATION.

**DYNAMIC DESIGN GROUP, INC**

David D Grorud  
(919) 601-1406  
DynamicDesignGroup@gmail.com

The drawings and specifications (plans) contained on these pages are the property of Dynamic Design Group and are offered to the named client or contractor for a conditional one time use. The conditional use is limited to the lot and subdivision specified herein, and only for said location. COPYRIGHT 2021

Contractor shall verify all conditions and dimensions prior to construction. Any error or omissions shall be reported to Dynamic Design Group for corrections or justification. Once construction has commenced, the contractor shall assume all responsibility. Dimensions govern over scale, code governs over dimensions.

CAPITOL  
PROJECT FOR: CITY HOMES  
LOCATION: MULTI  
LOT: MULTI  
SUBDIVISION: MULTI  
COUNTY: MULTI

**MIXON III**

PLAN NAME: B-2287-45GR  
DATE: 1-28-21

PLAN I.D.: \_\_\_\_\_

**S-1**  
SHEET



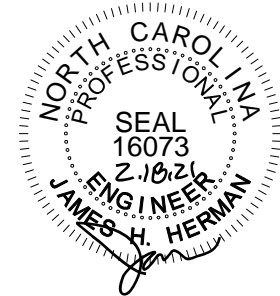

STRUCTURAL DESIGN BY:  
 SOUTHERN ENGINEERS, P.A.  
 3716 BENSON DR., RALEIGH, NC 27604  
 LICENSE: C-1287, PHONE: 919-878-1617  
 PROJECT # 21-2282 GR

\* Engineers seal applies only to structural components on this document. Seal does not include construction means, methods, techniques, sequences, procedures or safety precautions.  
 \* Any deviations or discrepancies on plans are to be brought to the immediate attention of Southern Engineers. Failure to do so will void Southern Engineers' liability.  
 \* Seal is valid for a project permitted within one year from date of seal.  
 \* Use of these plans constitutes approval of terms & conditions as defined in the customer agreement.

REFER TO "SD" SHEET(S) FOR STANDARD DETAILS, BRACING DETAILS AND STRUCTURAL NOTES.

**DYNAMIC DESIGN GROUP, INC**

David D Grorud  
 (919) 601-1406  
 DynamicDesignGroup@gmail.com

The drawings and specifications (plans) contained on these pages are the property of Dynamic Design Group and are offered to the named client or contractor for a conditional one time use. The conditional use is limited to the lot and subdivision specified herein, and only for said location. COPYRIGHT 2021

Contractor shall verify all conditions and dimensions prior to construction. Any error or omissions shall be reported to Dynamic Design Group for corrections or justification. Once construction has commenced, the contractor shall assume all responsibility. Dimensions govern over scale, code governs over dimensions.

CAPITOL  
 PROJECT FOR: CITY HOMES  
 LOCATION: MULTI  
 LOT: MULTI  
 SUBDIVISION: MULTI  
 COUNTY: MULTI

**MIXON III**  
 PLAN NAME  
**B-2287-45GR** 1-28-21  
 PLAN I.D. DATE

**S-1** SCREEN PORCH OPTIONS  
 SHEET

6x6 P.T. POST ON 24"x24"x8" CONCRETE FTG. (TYP). BRACE POSTS PER APPENDIX M.

Include Screened Porch →

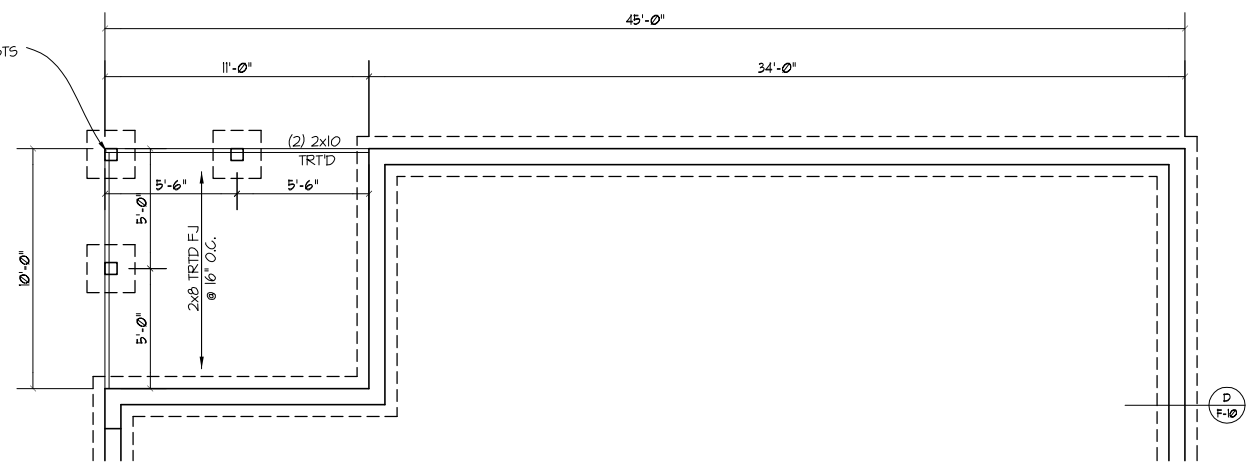

CRAWLSPACE FOUNDATION

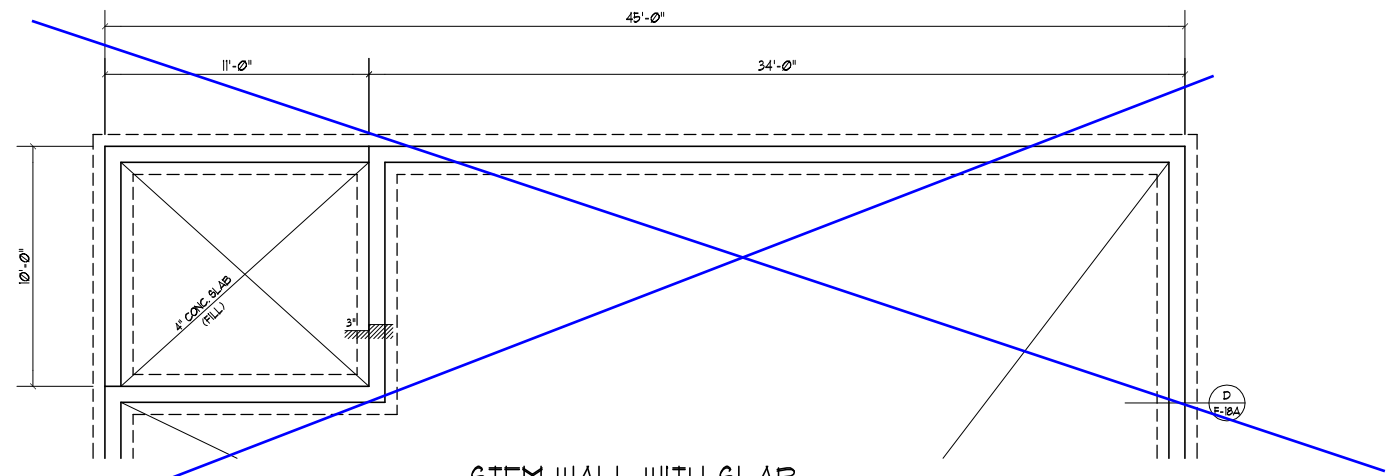

STEM WALL WITH SLAB FOUNDATION

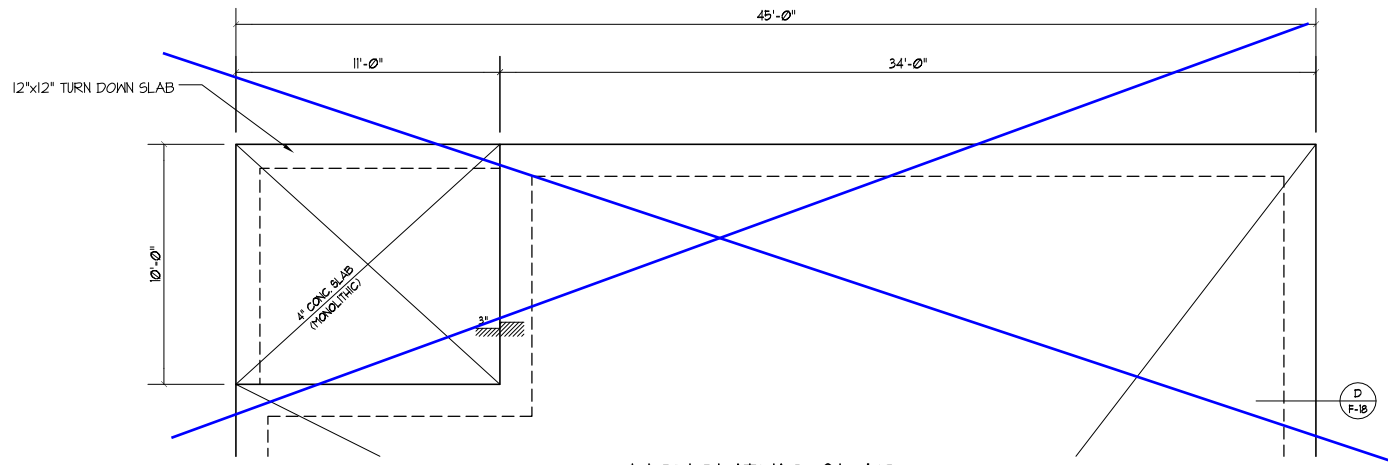

MONOLITHIC SLAB FOUNDATION

OPTIONAL SCREEN PORCH FOUNDATION PLANS  
 SCALE: ..... 1/8"=1'-0"

**FRAMING NOTES**

NC (2018 NCRC): Wind: 115-120 mph

- BRACING METHOD AND TYPE: CONTINUOUSLY SHEATHED WSP. GS-WSP. NOTE THAT THE WALL BRACING AMOUNT PROVIDED ON THE PLANS (DETAILS AND SPECIFICATIONS) IS GREATER THAN THE AMOUNT OF WALL BRACING REQUIRED BY THE CODE. SEE NOTES BELOW FOR DETAILS AND SPECIFICATIONS FOR WALL BRACING AND WALL FRAMING.
- EXTERIOR WALL SHEATHING: WALLS SHALL BE BRACED BY SHEATHING WALLS ON ALL STORIES WITH WOOD STRUCTURAL PANEL SHEATHING (WSP) (EXPOSURE B: 7/16", EXPOSURE C: 15/32"). SHEATHING SHALL BE ATTACHED WITH 8d NAILS AT A 6"X12" NAILING PATTERN (6" OC AT PANEL EDGES AND 12" OC AT INTERMEDIATE SUPPORTS). INSTALL BLOCKING AT ALL PANEL EDGES.
- WSP SHEATHING SHALL EXTEND TO THE UPPERMOST DOUBLE BEARING PLATE, BLOCK AT ROOF AND ATTACH BRACED WALLS PER CODE. WSP SHEATHING BETWEEN FLOORS SHALL BE SPLICED ALONG CONTINUOUS BAND OR THE WSP SHEATHING MAY BE SPLICED ACROSS STUDS (CONTINUOUS ACROSS FLOOR SYSTEM) WITH BLOCKING AT PANEL EDGES. (MINIMUM 12" BEYOND FLOOR BREAK) OR OTHER APPROVED METHOD.
- "HD" = HOLD-DOWN: HOLD-DOWN DEVICE (NOTED AS "HD" ON PLANS) SHALL BE AN 800 POUND CAPACITY ASSEMBLY AS NOTED ON PLANS. SEE DETAILS FOR HD ASSEMBLY.
  - \*\*GROUND/FIRST FLOOR: USE "HD HOLD-DOWN DETAIL" ON SD SHEET (OR EQUIV.)
  - \*\*UPPER FLOORS: ATTACH BASE OF KING STUD WITH A SIMPSON C522 STRAP DOWN ACROSS THE BAND AND DOWN TO A STUD BELOW OR HEADER BELOW. EXTEND STRAP 1" MIN ALONG EACH STUD (OR HEADER) AND ATTACH EACH END W/ (7) 8d NAILS.
- INTERIOR BRACED WALL: (NOTED AS "IBW" ON PLANS) ATTACH 1/2" GYPSUM BOARD (GB) ON EACH SIDE OF WALL WITH A MIN. OF 5d COOLER NAILS OR #6 SCREWS @ 1" O.C. ALONG THE EDGES AND AT INTERMEDIATE SUPPORTS.
- INTERIOR BRACED WALL-WOOD STRUCTURAL PANEL: (NOTED AS "IBW-WSP" ON PLANS). ATTACH ONE SIDE WITH 3/8" WSP SHEATHING WITH 8d NAILS AT A 6"X12" NAILING PATTERN (6" OC AT PANEL EDGES AND 12" OC AT INTERMEDIATE SUPPORTS). INSTALL BLOCKING AT ALL PANEL EDGES. ATTACH GB OVER WSP AS REQUIRED. ATTACH OPPOSITE SIDE WITH 1/2" GB WITH A MIN. OF 5d COOLER NAILS OR #6 SCREWS @ 1" OC ALONG THE EDGES AND AT INTERMEDIATE SUPPORTS.

**WHOLE HOUSE BRACING SUMMARY**  
 TOTAL REQUIRED BRACING: 56  
 TOTAL PROVIDED BRACING: 46  
 (IN FEET)

**HEADER / BEAM NOTES**

- ALL EXTERIOR AND LOAD BEARING HEADERS SHALL BE MIN. (2)2x6 (4" WALL) OR (3)2x6 (6" WALL) WITH (1) SUPPORT STUD AND (1) KING STUD, UNLESS NOTED OTHERWISE.
- THE NUMBER SHOWN AT BEAM AND HEADER SUPPORTS INDICATES THE NUMBER OF SUPPORT STUDS REQUIRED IN STUD POCKET OR COLUMN. THE NUMBER OF KING STUDS FOR HEADERS SHALL BE ACCORDING TO ITEM "a" IN TABLE R602.3(5) OR AS BELOW:
  - UP TO 4' SPAN: (1) KING STUD E/E
  - OVER 4' AND TO 8' SPAN: (2) KING STUDS E/E
  - OVER 8' AND UP TO 10' SPAN: (3) KING STUDS E/E
  - OVER 10' SPAN: (4) KING STUDS E/E

**TRUSS SYSTEM REQUIREMENTS**

NC (2018 NCRC): Wind: 115-120 mph

- TRUSS SYSTEM LAYOUTS (PLACEMENT PLANS) SHALL BE DESIGNED IN ACCORDANCE WITH SEALED STRUCTURAL PLANS. ANY NEED TO CHANGE TRUSSES SHALL BE COORDINATED WITH SOUTHERN ENGINEERS.
- TRUSS SCHEMATICS (PROFILES) SHALL BE PREPARED AND SEALED BY TRUSS MANUFACTURER.
- ALL TRUSSES SHALL BE DESIGNED FOR BEARING ON SPF #2 OR #3 PLATES OR LEDGERS (UNO).
- ALL REQUIRED ANCHORS FOR TRUSSES DUE TO UPLIFT OR BEARING SHALL MEET THE REQUIREMENTS AS SPECIFIED ON THE TRUSS SCHEMATICS.

**WOOD "I" JOISTS**

(SHALL BE ONE OF THE FOLLOWING):

- TJI 210 BY I-LEVEL
- LFI 20 FLUS BY LF
- BC1 5000s 1.8 BY BC
- ALL WOOD "I" JOISTS SHALL BE INSTALLED ACCORDING TO MANUFACTURER'S SPECIFICATIONS.
- INSTALL SQUASH BLOCKS, WEB STIFFENERS, ETC. AS REQUIRED BY AND ACCORDING TO THE I-JOIST MANUFACTURER'S SPECIFICATIONS AND INSTRUCTIONS.
- HANGERS FOR I-JOISTS ARE THE RESPONSIBILITY OF THE I-JOIST SUPPLIER.

LVL SCHEDULE	
IH	(2) 1.75x24 - 24'
4H	(4) 1.75x16 - 24'
5H	(2) 1.75x14 - 10'
6H	(2) 1.75x14 - 10'
7H	(2) 1.75x14 - 14'

Study in Lieu of Bedroom #5

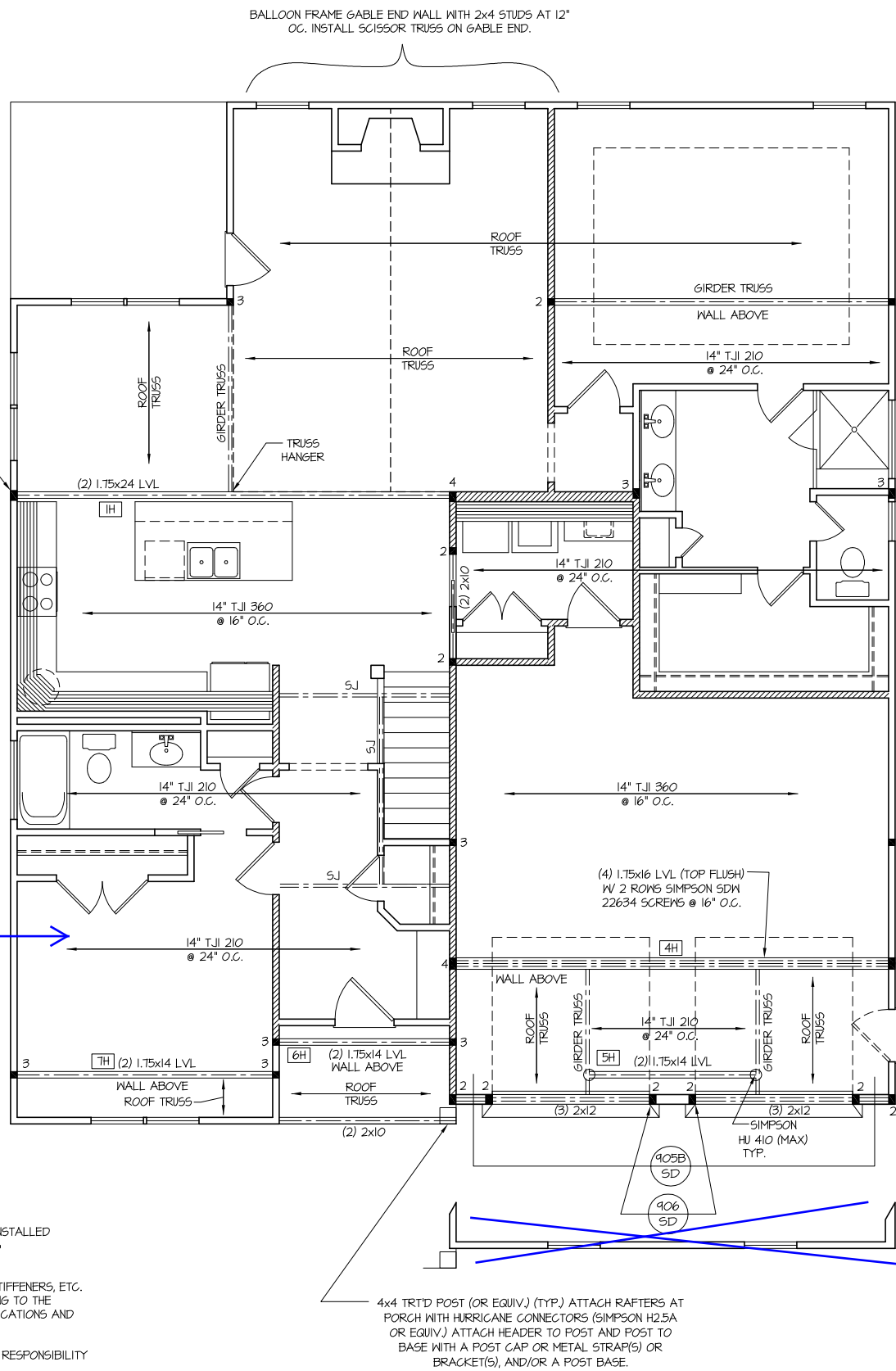

Include Tray Ceiling

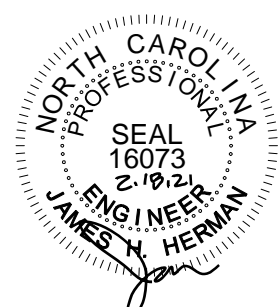

STRUCTURAL DESIGN BY:  
 SOUTHERN ENGINEERS, P.A.  
 3716 BENSON DR., RALEIGH, NC 27604  
 LICENSE: C-1287, PHONE: 919-878-1617  
 PROJECT # 21-2282 GR

- Engineer's seal applies only to structural components on this document. Seal does not include construction means, methods, techniques, sequences, procedures or safety precautions.
- Any deviations or discrepancies on plans are to be brought to the immediate attention of Southern Engineers. Failure to do so will void Southern Engineer's liability.
- Seal is valid for a project permitted within one year from date of seal.
- Use of these plans constitutes approval of terms & conditions as defined in the customer agreement.

REFER TO "SD" SHEET(S) FOR STANDARD DETAILS, BRACING DETAILS AND STRUCTURAL NOTES.

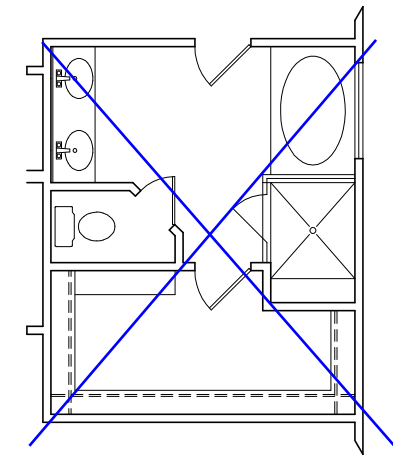

LVL SCHEDULE - SIDE LOAD	
ADD SLIV	(3) 1.75x18 - 20'

**ELEVATION "A"**  
**FIRST FLOOR CEILING /**  
**STRUCTURAL PLAN**  
**W/ BEDROOM #4 / BATH OPTION**

SCALE ..... 1/8"=1'-0"

- NOTES:**
- SHADED WALLS DENOTE LOAD BEARING WALLS.
  - DENOTES SOLID STUDS.

**DYNAMIC DESIGN GROUP, INC**  
 David D Grorud  
 (919) 601-1406  
 DynamicDesignGroup@gmail.com

The drawings and specifications (plans) contained on these pages are the property of Dynamic Design Group and are offered to the named client or contractor for a conditional one time use. The conditional use is limited to the lot and subdivision specified herein, and only for said location. COPYRIGHT 2021  
 Contractor shall verify all conditions and dimensions prior to construction. Any error or omissions shall be reported to Dynamic Design Group for corrections or justification. Once construction has commenced, the contractor shall assume all responsibility. Dimensions govern over scale, code governs over dimensions.

**CAPITOL**  
 PROJECT FOR: CITY HOMES  
 LOCATION: MULTI  
 LOT: MULTI  
 SUBDIVISION: MULTI  
 COUNTY: MULTI

**MIXON III**  
 PLAN NAME  
**B-2287-45GR**  
 PLAN I.D.  
**1-28-21**  
 DATE

**S-2A**  
 SHEET

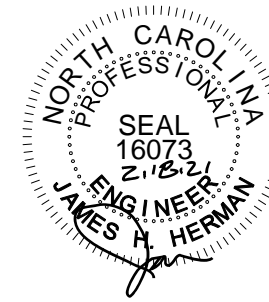

STRUCTURAL DESIGN BY:  
 SOUTHERN ENGINEERS, P.A.  
 3716 BENSON DR., RALEIGH, NC 27604  
 LICENSE: C-1287, PHONE: 919-878-1617  
 PROJECT # 21-2282 GR

- Engineers seal applies only to structural components on this document. Seal does not include construction means, methods, techniques, sequences, procedures or safety precautions.
- Any deviations or discrepancies on plans are to be brought to the immediate attention of Southern Engineers. Failure to do so will void Southern Engineer's liability.
- Seal is valid for a project permitted within one year from date of seal.
- Use of these plans constitutes approval of terms & conditions as defined in the customer agreement.

REFER TO "SD" SHEET(S) FOR STANDARD DETAILS, BRACING DETAILS AND STRUCTURAL NOTES.

Include Screened Porch

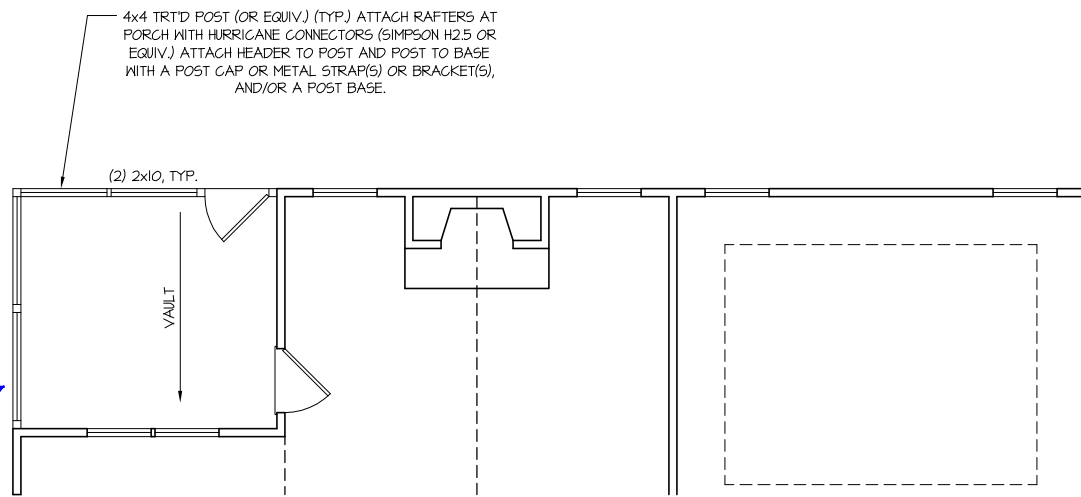

CEILING / STRUCTURAL PLAN

SCALE: ----- 1/8" = 1'-0"

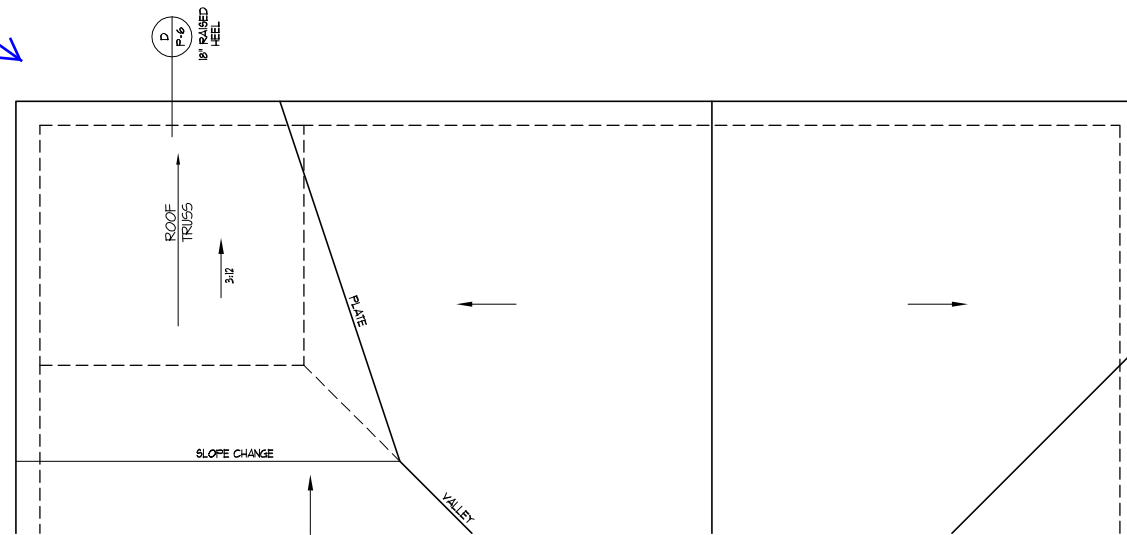

ROOF FRAMING PLAN

SCALE: ----- 1/8" = 1'-0"

ROOF FRAMING NOTES:

NC (2018 NCRG): Wind: 115-120 mph

- 2x8 @ 16" O.C. WITH 2x10 RIDGE, UNO.
- (2) 2x10 OR 1.75x11.875 LVL HIP. (2) 2x10 HIPs MAY BE SPLICED WITH A MIN. 6'-0" OVERLAP AT CENTER
- (2) 2x10 OR 1.75x9.25 LVL VALLEY. DO NOT SPLICE VALLEYS
- 1.75x11.875 LVL OR (2) 1.75x9.25 LVL VALLEY
- FALSE FRAME VALLEY ON 2x10 FLAT PLATE
- 2x6 RAFTERS @ 16" O.C. W/ 2x8 RIDGE, UNO.
- 2x10 RAFTERS @ 16" O.C. W/ 2x12 RIDGE, UNO.
- EXTEND RIDGE 12" BEYOND INTERSECTION

- "SR" = SINGLE RAFTER
- "DR" = DOUBLE RAFTER
- "TR" = TRIPLE RAFTER
- "RS" = ROOF SUPPORT
- "■" = (3) STUD OR 4x4 POST FOR ROOF SUPPORT (USE 2x6 OR 6x6 FOR SUPPORT POSTS OVER 10'-0" IN HEIGHT)
- ATTACH VAULTED RAFTERS WITH HURRICANE CLIPS: SIMPSON "H-2.5A" OR EQUIVALENT
- INSTALL RAFTER TIES AND COLLAR TIES PER SECTION R802.3.1 OF THE 2018 NC RESIDENTIAL CODE.

OPTIONAL  
SCREEN PORCH

The drawings and specifications (plans) contained on these pages are the property of Dynamic Design Group and are offered to the named client or contractor for a conditional one time use. The conditional use is limited to the lot and subdivision specified herein, and only for said location. COPYRIGHT 2021

Contractor shall verify all conditions and dimensions prior to construction. Any error or omissions shall be reported to Dynamic Design Group for corrections or justification. Once construction has commenced, the contractor shall assume all responsibility. Dimensions govern over scale, code governs over dimensions.

CAPITOL  
PROJECT FOR: CITY HOMES  
LOCATION: MULTI  
LOT: MULTI  
SUBDIVISION: MULTI  
COUNTY: MULTI

MIXON III  
PLAN NAME  
B-2287-45GR 1-28-21  
PLAN I.D. DATE

S-2 SCREEN PORCH OPTION SHEET

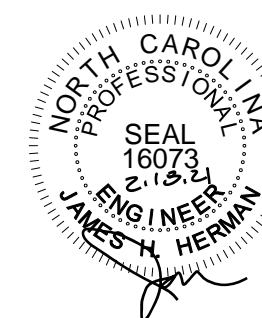

STRUCTURAL DESIGN BY:  
 SOUTHERN ENGINEERS, P.A.  
 3716 BENSON DR., RALEIGH, NC 27604  
 LICENSE: C-1287, PHONE: 919-878-1617  
 PROJECT # 21-2282 GL

- Engineers seal applies only to structural components on this document. Seal does not include construction means, methods, techniques, sequences, procedures or safety precautions.
- Any deviations or discrepancies on plans are to be brought to the immediate attention of Southern Engineers. Failure to do so will void Southern Engineer's liability.
- Seal is valid for a project permitted within one year from date of seal.
- Use of these plans constitutes approval of terms & conditions as defined in the customer agreement.

REFER TO "SD" SHEET(S) FOR STANDARD DETAILS, BRACING DETAILS AND STRUCTURAL NOTES.

**HEADER / BEAM NOTES**

- ALL EXTERIOR AND LOAD BEARING HEADERS SHALL BE MIN. (2)2x6 (4" WALL) OR (3)2x6 (6" WALL) WITH (1) SUPPORT STUD AND (1) KING STUD, UNLESS NOTED OTHERWISE.
- THE NUMBER SHOWN AT BEAM AND HEADER SUPPORTS INDICATES THE NUMBER OF SUPPORT STUDS REQUIRED IN STUD POCKET OR COLUMN. THE NUMBER OF KING STUDS FOR HEADERS SHALL BE ACCORDING TO ITEM "d" IN TABLE R602.3(5) OR AS BELOW:
  - UP TO 4' SPAN: (1) KING STUD E/E
  - OVER 4' AND TO 8' SPAN: (2) KING STUDS E/E
  - OVER 8' AND UP TO 10' SPAN: (3) KING STUDS E/E
  - OVER 10' SPAN: (4) KING STUDS E/E

**TRUSS SYSTEM REQUIREMENTS**  
 NC (2018 NGRG): Wind: 115-120 mph

- TRUSS SYSTEM LAYOUTS (PLACEMENT PLANS) SHALL BE DESIGNED IN ACCORDANCE WITH SEALED STRUCTURAL PLANS. ANY NEED TO CHANGE TRUSSES SHALL BE COORDINATED WITH SOUTHERN ENGINEERS.
- TRUSS SCHEMATICS (PROFILES) SHALL BE PREPARED AND SEALED BY TRUSS MANUFACTURER.
- ALL TRUSSES SHALL BE DESIGNED FOR BEARING ON SPF #2 OR #3 PLATES OR LEDGERS (NO).
- ALL REQUIRED ANCHORS FOR TRUSSES DUE TO UPLIFT OR BEARING SHALL MEET THE REQUIREMENTS AS SPECIFIED ON THE TRUSS SCHEMATICS.

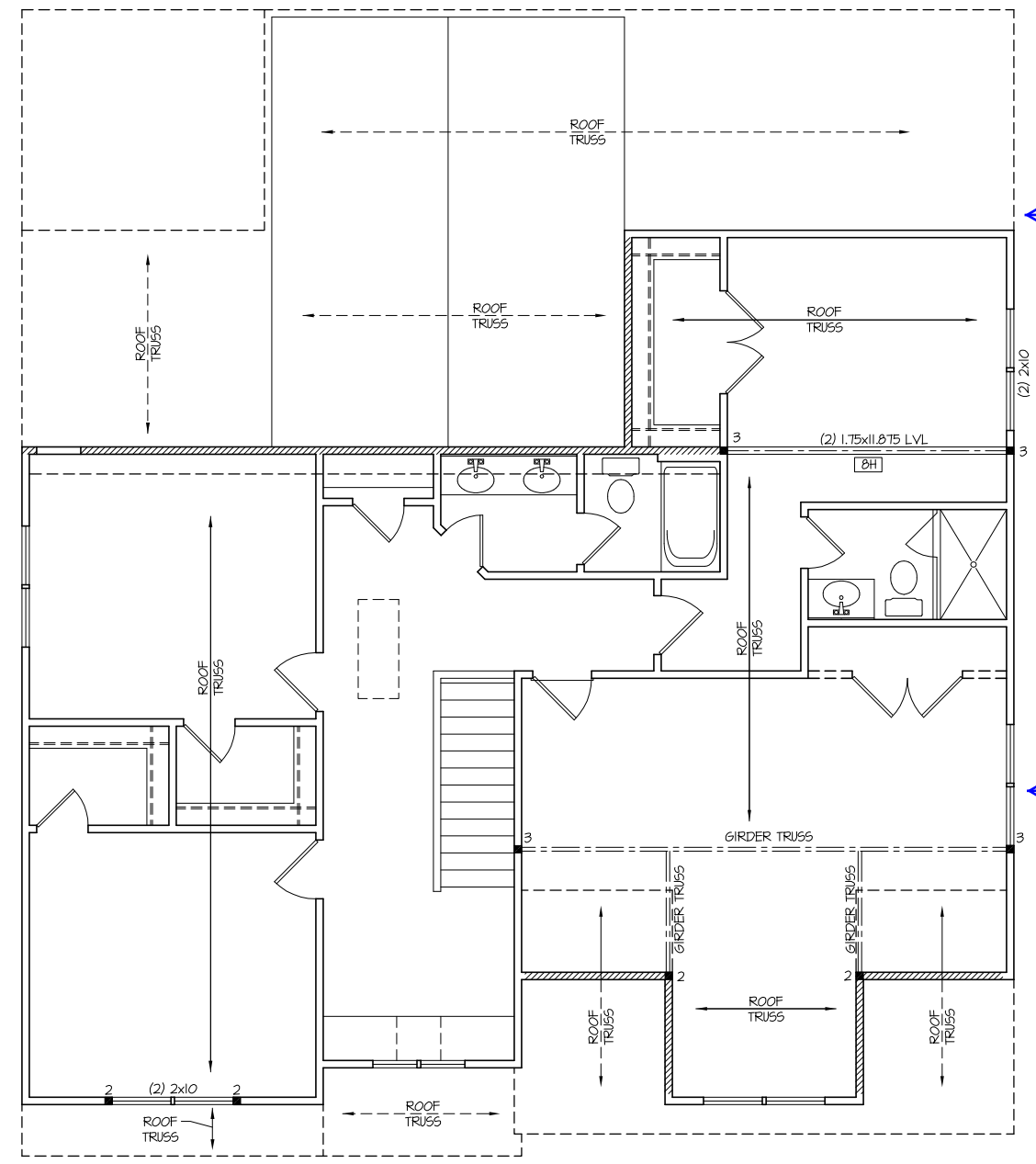

LVL. SCHEDULE	
8H	(2) 1.75x11.875 - 14'-0"

ELEVATION "A"  
 SECOND FLOOR CEILING /  
 STRUCTURAL PLAN  
 W/ BEDROOM #4 / BATH OPTION  
 SCALE ----- 1/8"=1'-0"

NOTES:  
 1) SHADED WALLS DENOTE LOAD BEARING WALLS.  
 2) ■ DENOTES SOLID STUDS.

**DYNAMIC DESIGN GROUP, INC**  
 David D Grorud  
 (919) 601-1406  
 DynamicDesignGroup@gmail.com

The drawings and specifications (plans) contained on these pages are the property of Dynamic Design Group and are offered to the named client or contractor for a conditional one time use. The conditional use is limited to the lot and subdivision specified herein, and only for said location. COPYRIGHT 2021

Contractor shall verify all conditions and dimensions prior to construction. Any error or omissions shall be reported to Dynamic Design Group for corrections or justification. Once construction has commenced, the contractor shall assume all responsibility. Dimensions govern over scale, code governs over dimensions.

CAPITOL  
 PROJECT FOR: CITY HOMES  
 LOCATION: MULTI  
 LOT: MULTI  
 SUBDIVISION: MULTI  
 COUNTY: MULTI

**MIXON III**  
 PLAN NAME  
**B-2287-45GR** 1-28-21  
 PLAN I.D. DATE

**S-3A**  
 SHEET

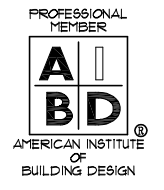
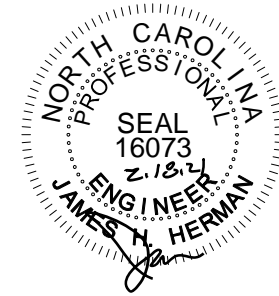

STRUCTURAL DESIGN BY:  
 SOUTHERN ENGINEERS, P.A.  
 3716 BENSON DR., RALEIGH, NC 27604  
 LICENSE: C-1287, PHONE: 419-878-1617  
 PROJECT # 21-2282 GR

- Engineers seal applies only to structural components on this document. Seal does not include construction means, methods, techniques, sequences, procedures or safety precautions.
- Any deviations or discrepancies on plans are to be brought to the immediate attention of Southern Engineers. Failure to do so will void Southern Engineer's liability.
- Seal is valid for a project permitted within one year from date of seal.
- Use of these plans constitutes approval of terms & conditions as defined in the customer agreement.

REFER TO "SD" SHEET(S) FOR STANDARD DETAILS, BRACING DETAILS AND STRUCTURAL NOTES.

**TRUSS SYSTEM REQUIREMENTS**  
 NC (2018 NCRC): Wind: 115-120 mph

- TRUSS SYSTEM LAYOUTS (PLACEMENT PLANS) SHALL BE DESIGNED IN ACCORDANCE WITH SEALED STRUCTURAL PLANS. ANY NEED TO CHANGE TRUSSES SHALL BE COORDINATED WITH SOUTHERN ENGINEERS.
- TRUSS SCHEMATICS (PROFILES) SHALL BE PREPARED AND SEALED BY TRUSS MANUFACTURER.
- ALL TRUSSES SHALL BE DESIGNED FOR BEARING ON SFF #2 OR #3 PLATES OR LEDGERS (UNO).
- ALL REQUIRED ANCHORS FOR TRUSSES DUE TO UPLIFT OR BEARING SHALL MEET THE REQUIREMENTS AS SPECIFIED ON THE TRUSS SCHEMATICS.

Include Screened Porch

Include Bedroom #4 & Rec Room and Closet

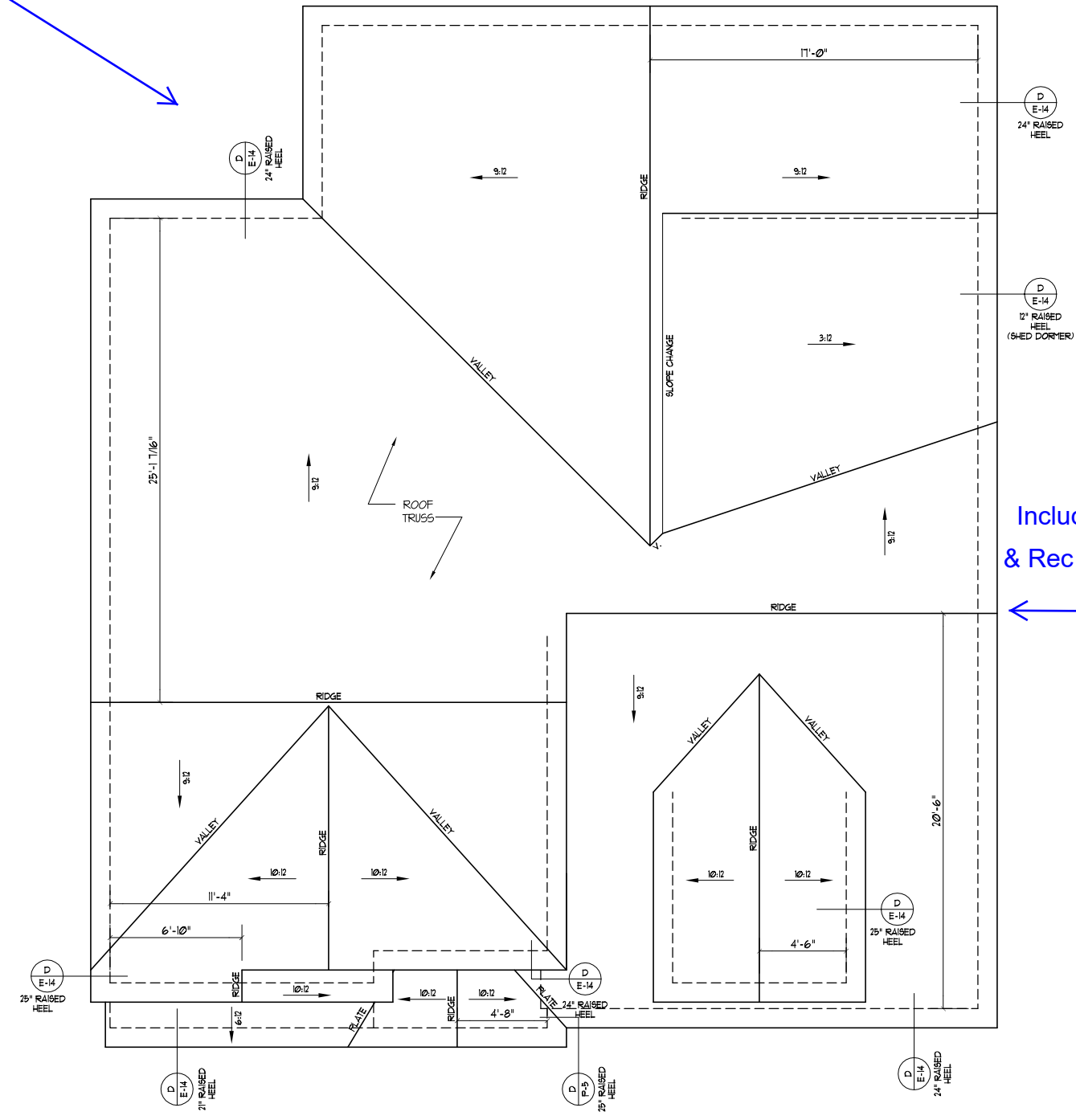

ATTIC VENTILATION	
REQUIRED	* 2318 SQ FT OF ATTIC / 300 = 7.73 SQ FT. OF INLET & OUTLET
PROVIDED (INLET)	SOFFIT 07 SQ. FT. PER x 72 LINEAR FT. = 504 SQ. FT. 45% (TOTAL OF LINEAR FT. OF VENT. OF VENT. (TOTAL OF
(OUTLET)	RIDGE 11 SQ. FT. PER x 50 LINEAR FT. = 616 SQ. FT. 55% (TOTAL OF LINEAR FT. OF VENT. OF VENT. (TOTAL OF
	1120 TOTAL SQ. FT. OF VENT.

\* INCLUDES OPT SCREEN PORCH

**ELEVATION "A"  
 ROOF FRAMING PLAN  
 W/ BEDROOM #4 / BATH OPTION**  
 SCALE ----- 1/8"=1'-0"

- NOTES:
- SEE SHEET D-1 FOR DETAILS.
  - DIMENSIONS ARE FROM EXT. OF FRAMING TO CENTER LINE OF RIDGE.

**DYNAMIC DESIGN GROUP, INC**  
 David D Grorud  
 (919) 601-1406  
 DynamicDesignGroup@gmail.com

The drawings and specifications (plans) contained on these pages are the property of Dynamic Design Group and are offered to the named client or contractor for a conditional one time use. The conditional use is limited to the lot and subdivision specified herein, and only for said location. COPYRIGHT 2021  
 Contractor shall verify all conditions and dimensions prior to construction. Any error or omissions shall be reported to Dynamic Design Group for corrections or justification. Once construction has commenced, the contractor shall assume all responsibility. Dimensions govern over scale, code governs over dimensions.

CAPITOL  
 PROJECT FOR: CITY HOMES  
 LOCATION: MULTI  
 LOT: MULTI  
 SUBDIVISION: MULTI  
 COUNTY: MULTI

**MIXON III**  
 PLAN NAME  
**B-2287-45GR** 1-28-21  
 PLAN I.D. DATE

**S-4A**  
 SHEET

**STRUCTURAL NOTES**  
NC (2018 NCRG): Wind: 115-120 mph

- ENGINEER'S SEAL APPLIES ONLY TO STRUCTURAL COMPONENTS INCLUDING ROOF RAFTERS, HIPs, VALLEYS, RIDGES, FLOORS, WALLS, BEAMS AND HEADERS, COLUMNS, CANTILEVERS, OFFSET LOAD BEARING WALLS, PIER & GIRDER SYSTEM, FOOTING, AND PILING SYSTEM. ENGINEER'S SEAL DOES NOT CERTIFY DIMENSIONAL ACCURACY OR ARCHITECTURAL LAYOUT INCLUDING ROOF SYSTEM. ALL REQUIREMENTS FOR PROFESSIONAL CERTIFICATION SHALL BE PROVIDED BY THE APPROPRIATE PROFESSIONAL SOUTHERN ENGINEERS, P.A. CERTIFIES ONLY THE STRUCTURAL COMPONENTS AS SPECIFICALLY STATED.
- ALL CONSTRUCTION SHALL CONFORM TO THE LATEST REQUIREMENTS OF RESIDENTIAL CODE, PLUS ALL LOCAL CODES AND REGULATIONS. THE STRUCTURAL ENGINEER IS NOT RESPONSIBLE FOR, AND WILL NOT HAVE CONTROL OF, CONSTRUCTION MEANS, METHODS, TECHNIQUES, SEQUENCES OR PROCEDURES, OR FOR SAFETY PRECAUTIONS AND PROGRAMS IN CONNECTION WITH THE CONSTRUCTION WORK, NOR WILL THE ENGINEER BE RESPONSIBLE FOR THE CONTRACTOR'S FAILURE TO CARRY OUT THE CONSTRUCTION WORK IN ACCORDANCE WITH THE CONTRACT DOCUMENTS. "CONSTRUCTION REVIEW" SERVICES ARE NOT PART OF OUR CONTRACT. ALL MEMBERS SHALL BE FRAMED ANCHORED, TIED AND BRACED IN ACCORDANCE WITH GOOD CONSTRUCTION PRACTICE AND THE BUILDING CODE.
- DESIGN LOADS (LISTED AS: LIVE LOAD, DEAD LOAD, DEFLECTION)
  - ROOMS OTHER THAN SLEEPING ROOMS: (40 PSF, 10 PSF, L/360)
  - SLEEPING ROOMS: (30 PSF, 10 PSF, L/360)
  - ATTIC WITH PERMANENT STAIR: (40 PSF, 10 PSF, L/360)
  - ATTIC WITHOUT PERMANENT STAIR: (20 PSF, 10 PSF, L/360)
  - ATTIC WITHOUT STORAGE: (10 PSF, 10 PSF, L/240)
  - STAIRS: (40 PSF, 10 PSF, L/360)
  - EXTERIOR BALCONIES: (60 PSF, 10 PSF, L/360)
  - DECKs: (40 PSF, 10 PSF, L/360)
  - GUARDRAILS AND HANDRAILS: (200 LBS)
  - PASSENGER VEHICLE GARAGES: (50 PSF, 10 PSF, L/360)
  - FIRE ESCAPES: (40 PSF, 10 PSF, L/360)
  - SNOW: (20 PSF)
- WALLS SHALL BE BRACED BY SHEATHING WALLS ON ALL STORIES WITH WOOD STRUCTURAL PANELS. SEE FRAMING NOTES FOR THICKNESS AND NAILING REQUIREMENTS.
- SEE APPENDIX M (DCA6) FOR EXTERIOR DECK REQUIREMENTS INCLUDING ATTACHMENTS FOR LATERAL LOADS.
- CONCRETE SHALL HAVE A MINIMUM 28 DAY STRENGTH OF 3000 PSI AND A MAXIMUM SLUMP OF 5 INCHES UNLESS NOTED OTHERWISE (NO). AIR ENTRAINED PER TABLE 402.2. ALL CONCRETE SHALL BE PROPORTIONED, MIXED, HANDLED, SAMPLED, TESTED, AND PLACED IN ACCORDANCE WITH ACI STANDARDS. ALL SAMPLES FOR PUMPING SHALL BE TAKEN FROM THE EXIT END OF THE PUMP. CONTROL JOINTS IN SLABS SHALL BE SPACED ON A GRID OF +30 TIMES THE DEPTH (D). CONTROL JOINTS SHALL BE SAWCUT TO A DEPTH OF 1/D. (I.E. 4" CONCRETE SLABS SHALL HAVE 1/4" DEEP CONTROL JOINTS SAWCUT IN SLAB ON A +10'-0" x +10'-0" GRID).
- ALLOWABLE SOIL BEARING PRESSURE ASSUMED TO BE 2000 PSF. THE CONTRACTOR MUST CONTACT A GEOTECHNICAL ENGINEER AND THE STRUCTURAL ENGINEER IF UNSATISFACTORY SUBSURFACE CONDITIONS ARE ENCOUNTERED. THE SURFACE AREA ADJACENT TO THE FOUNDATION WALL SHALL BE PROVIDED WITH ADEQUATE DRAINAGE, AND SHALL BE GRADED SO AS TO DRAIN SURFACE WATER AWAY FROM FOUNDATION WALLS.
- ALL FRAMING LUMBER SHALL BE SPP #2 (Fb = 875 PSI) UNLESS NOTED OTHERWISE (NO). ALL TREATED LUMBER SHALL BE SYP #2. PLATE MATERIAL MAY BE SYP #3 OR SYP #3 (Fc(perp) = 425 PSI - MIN).
  - L.V.L. SHALL BE LAMINATED VENEER LUMBER: Fb=2600 PSI, Fv=285 PSI, E=1.4x10<sup>6</sup> PSI.
  - P.S.L. SHALL BE PARALLEL STRAND LUMBER: Fb=2400 PSI, Fv=240 PSI, E=2.0x10<sup>6</sup> PSI.
  - L.S.L. SHALL BE LAMINATED STRAND LUMBER: Fb=2250 PSI, Fv=400 PSI, E=1.55x10<sup>6</sup> PSI. INSTALL ALL CONNECTIONS PER MANUFACTURER'S INSTRUCTIONS.
- ALL ROOF TRUSS AND I-JOIST LAYOUTS SHALL BE PREPARED IN ACCORDANCE WITH THE SEALED STRUCTURAL DRAWINGS. TRUSSES AND I-JOISTS SHALL BE INSTALLED ACCORDING TO THE MANUFACTURER'S SPECIFICATIONS. ANY CHANGE IN TRUSS OR I-JOIST LAYOUT SHALL BE COORDINATED WITH SOUTHERN ENGINEERS.
- ALL STRUCTURAL STEEL SHALL BE ASTM A-36. STEEL BEAMS SHALL BE SUPPORTED AT EACH END WITH A MINIMUM BEARING LENGTH OF 3 1/2" INCHES AND FULL FLANGE WIDTH. PROVIDE SOLID BEARING FROM BEAM SUPPORT TO FOUNDATION. BEAMS SHALL BE ATTACHED TO EACH SUPPORT WITH TWO LAG SCREWS (1/2" DIAMETER x 4" LONG). LATERAL SUPPORT IS CONSIDERED ADEQUATE PROVIDING THE JOIST ARE TOE NAILED TO THE SOLE PLATE, AND SOLE PLATE IS NAILED OR BOLTED TO THE BEAM FLANGE @ 48" O.C. ALL STEEL TUBING SHALL BE ASTM A500. LAP ALL REBAR SPLICES 30 BAR DIAMETERS.
- REBAR SHALL BE DEFORMED STEEL, ASTM615, GRADE 60.
- FLITCH BEAMS SHALL BE BOLTED TOGETHER USING (2) ROWS OF 1/2" DIAMETER BOLTS (ASTM A325) WITH WASHERS PLACED UNDER THE THREADED END OF BOLT. BOLTS SHALL BE SPACED AT 24" O.C. (MAX), AND STAGGERED AT THE TOP AND BOTTOM OF BEAM (2" EDGE DISTANCE), WITH 2 BOLTS LOCATED AT 6" FROM EACH END.
- BRICK LINTELS (WHEN REQUIRED) SHALL BE 3 1/2"x3 1/2"x1/4" STEEL ANGLE FOR UP TO 6'-0" SPAN AND 6"x4"x5/16" STEEL ANGLE WITH 6" LEG VERTICAL FOR SPANS UP TO 9'-0". SEE PLANS FOR SPANS OVER 9'-0". SEE ALSO SECTION R703.13 LINTELS.

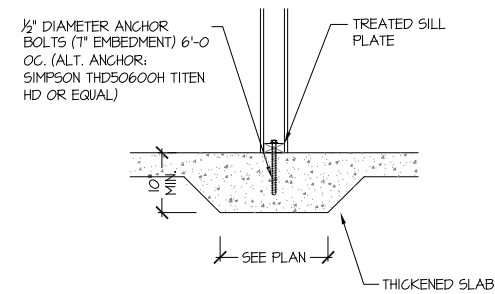

115-120 MPH 104A SD THICKENED SLAB (INTERIOR BEARING WALL)

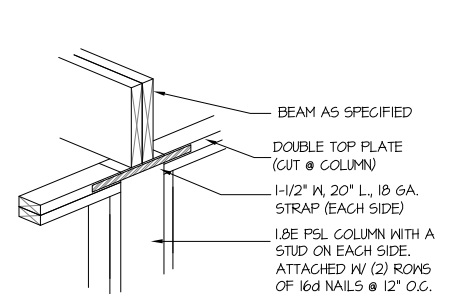

205B SD DIRECT BEAM BEARING NT5

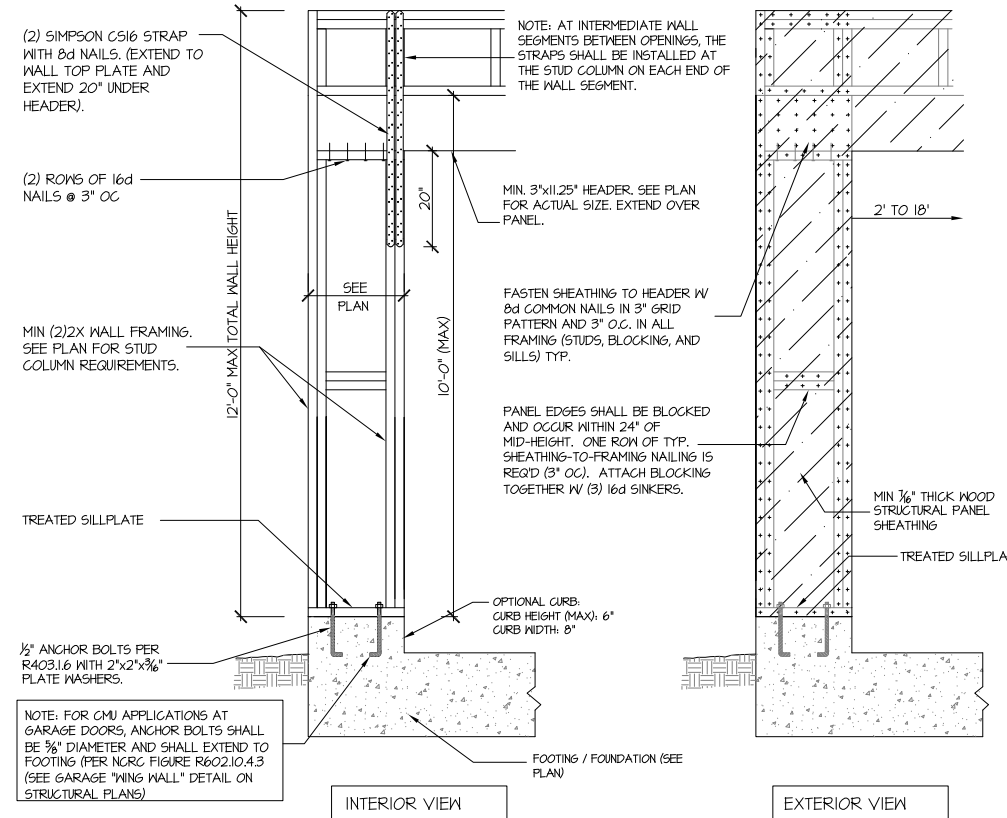

905B SD CS-PF: CONTINUOUS PORTAL FRAME CONSTRUCTION DETAIL AND APPLICATION BASED ON NCRG FIGURE R602.10.1 - PORTAL FRAME CONSTRUCTION

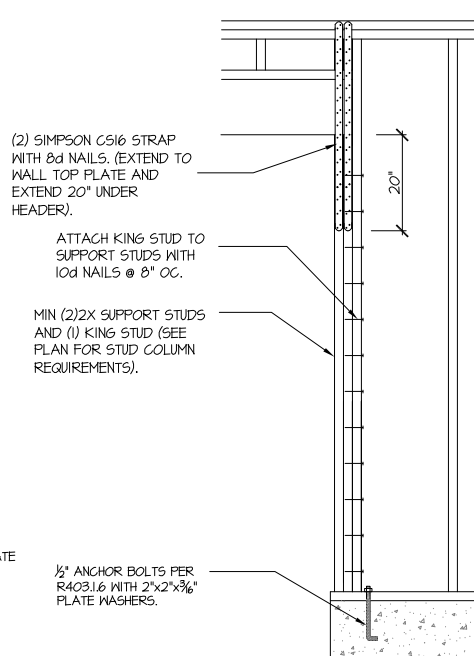

906 SD CS-PF: END CONDITION DETAIL (FOR USE WITH SINGLE CS-PF CONDITION) DETAIL AND APPLICATION BASED ON NCRG FIGURE R602.10.1 - PORTAL FRAME CONSTRUCTION

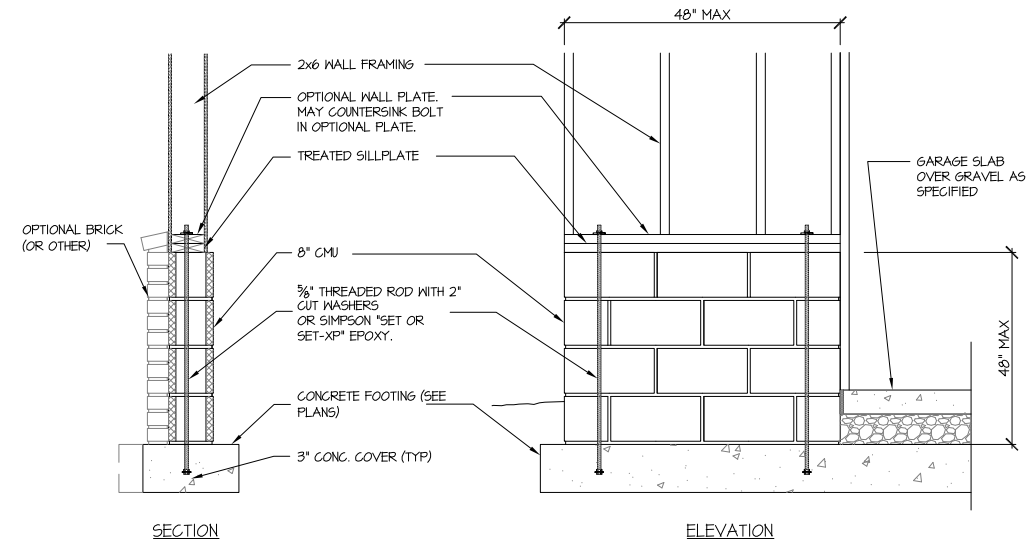

907 SD GARAGE 'WING WALL' REINFORCING PER IRC FIGURE R602.10.4.3

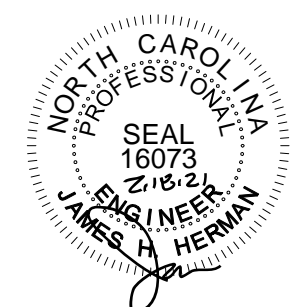

STRUCTURAL DESIGN BY:  
SOUTHERN ENGINEERS, P.A.  
3716 BENSON DR., RALEIGH, NC 27609  
LICENSE: C-1287, PHONE: 919-878-1617  
PROJECT # 21-2282 GR

Engineer's seal applies only to structural components on this document. Seal does not include construction means, methods, techniques, sequences, procedures or safety precautions. Any deviations or discrepancies on plans are to be brought to the immediate attention of Southern Engineers. Failure to do so will void Southern Engineer's liability. Seal is valid for a project permitted within one year from date of seal. Use of these plans constitutes approval of terms & conditions as defined in the customer agreement.

**DYNAMIC DESIGN GROUP, INC**

David D Grorud  
(919) 601-1406  
DynamicDesignGroup@gmail.com

The drawings and specifications (plans) contained on these pages are the property of Dynamic Design Group and are offered to the named client or contractor for a conditional one time use. The conditional use is limited to the lot and subdivision specified herein, and only for said location. COPYRIGHT 2021

Contractor shall verify all conditions and dimensions prior to construction. Any error or omissions shall be reported to Dynamic Design Group for corrections or justification. Once construction has commenced, the contractor shall assume all responsibility. Dimensions govern over scale, code governs over dimensions.

CAPITOL PROJECT FOR: CITY HOMES  
LOCATION: MULTI  
LOT: MULTI  
SUBDIVISION: MULTI  
COUNTY: MULTI

**MIXON III**

PLAN NAME: B-2287-45GR  
DATE: 1-28-21

PLAN I.D.: 45GR

**SD SHEET**

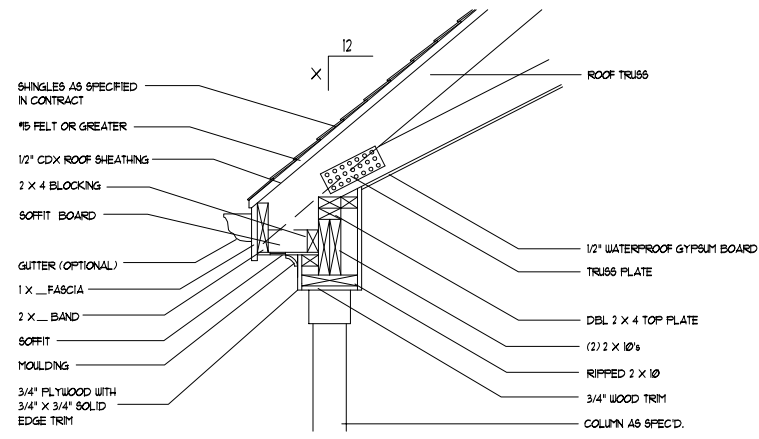

D  
P-6 (NTS)

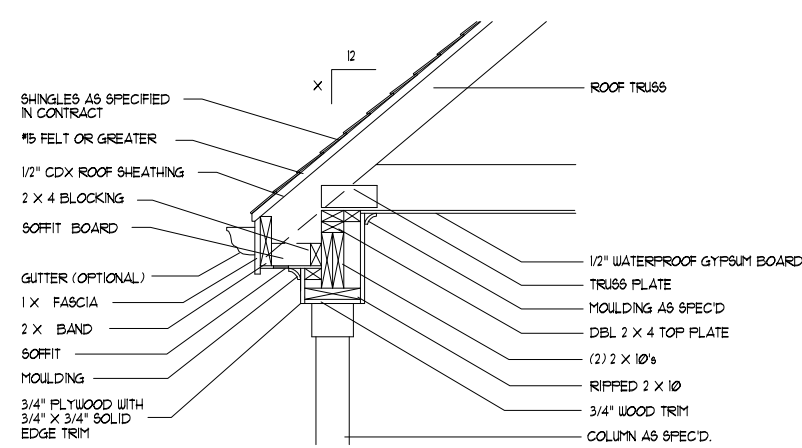

D  
P-5 (NTS)

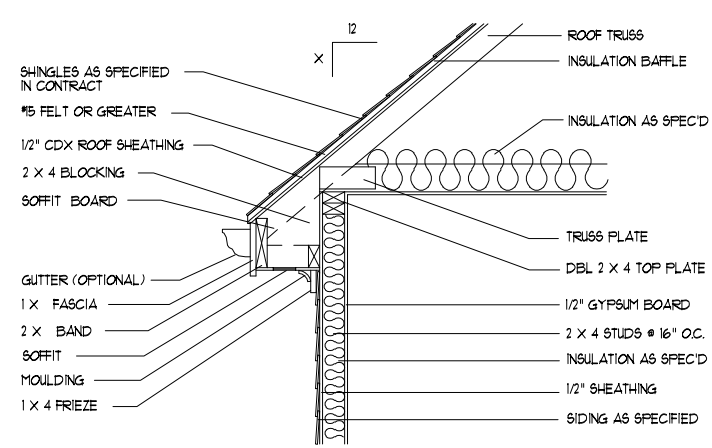

D  
E-14 (NTS)

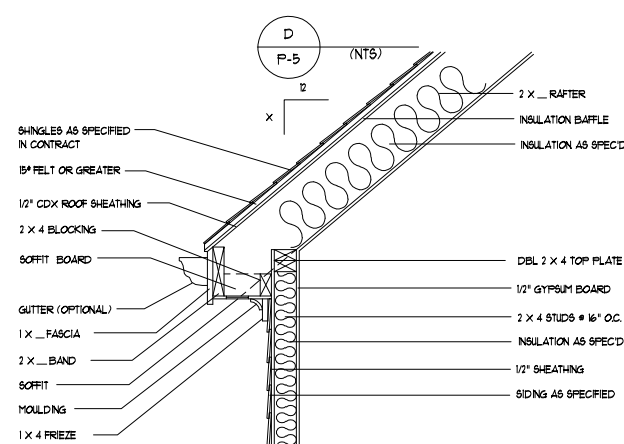

D  
E-13 (NTS)

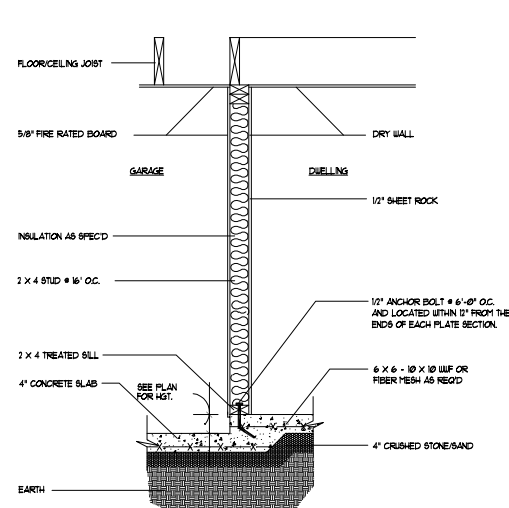

D  
GU-14 (NTS)

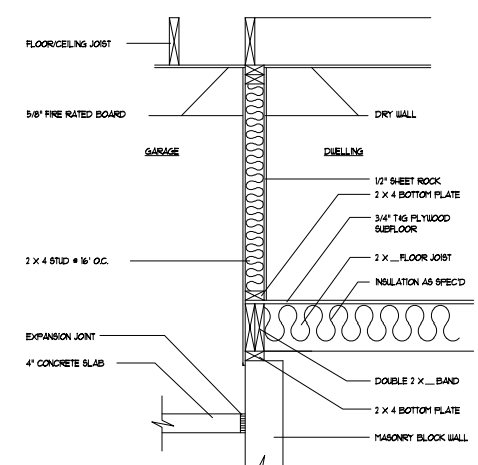

D  
GU-1 (NTS)

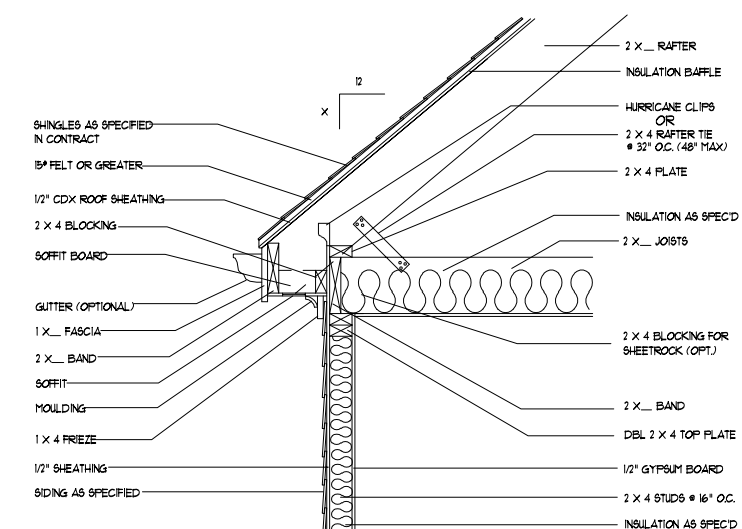

D  
E-10 (NTS)

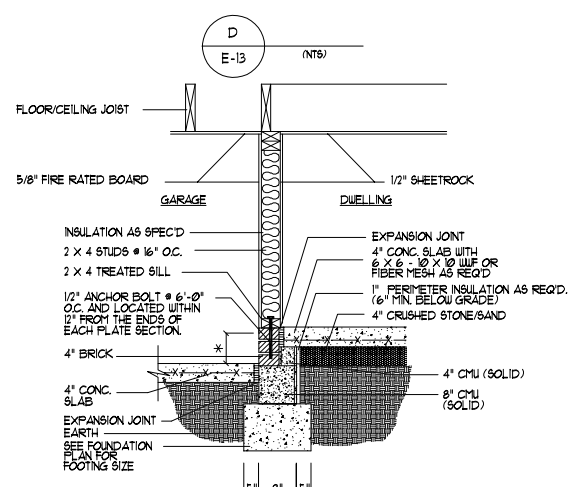

D  
GU-13 (NTS)

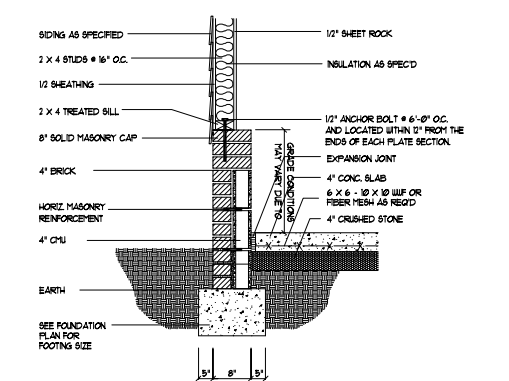

D  
F-16 (NTS)

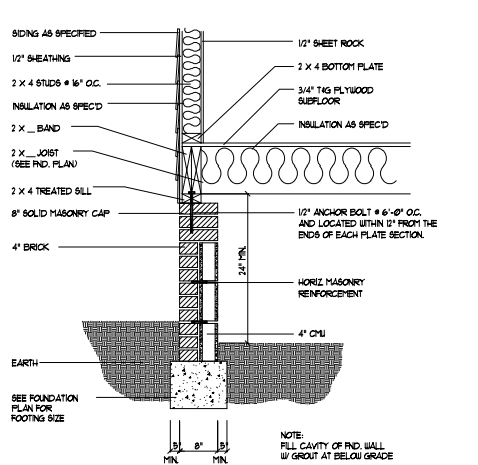

D  
F-10 (NTS)

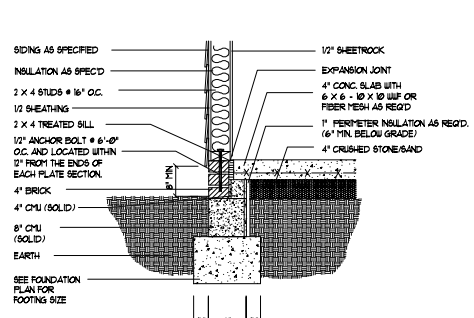

D  
F-18A (NTS)

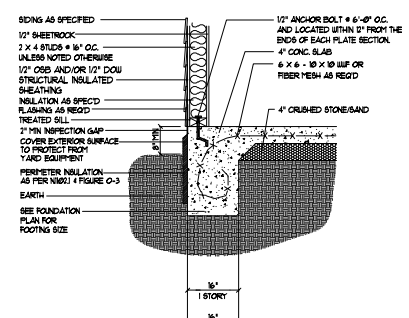

D  
F-18 (NTS)

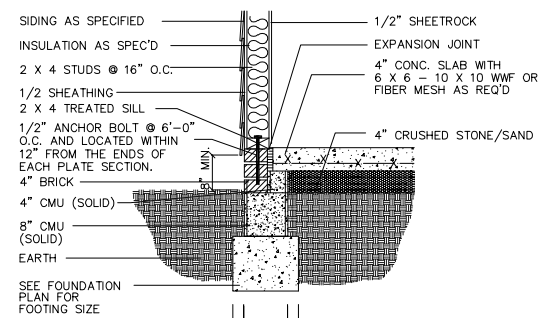

D  
F-16A (NTS)

**DYNAMIC DESIGN GROUP, INC**  
David D Grorud  
(919) 601-1406  
DynamicDesignGroup@gmail.com

The drawings and specifications (plans) contained on these pages are the property of Dynamic Design Group and are offered to the named client or contractor for a conditional one time use. The conditional use is limited to the lot and subdivision specified herein, and only for said location. COPYRIGHT 2021  
Contractor shall verify all conditions and dimensions prior to construction. Any error or omissions shall be reported to Dynamic Design Group for corrections or justification. Once construction has commenced, the contractor shall assume all responsibility. Dimensions govern over scale, code governs over dimensions.

PROJECT FOR: CAPITOL CITY HOMES  
LOCATION: MULTI  
LOT: MULTI  
SUBDIVISION: MULTI  
COUNTY: MULTI

**MIXON III**  
PLAN NAME  
**B-2287-45GR** 1-28-21  
DATE  
PLAN I.D.

**D-1A**  
SHEET

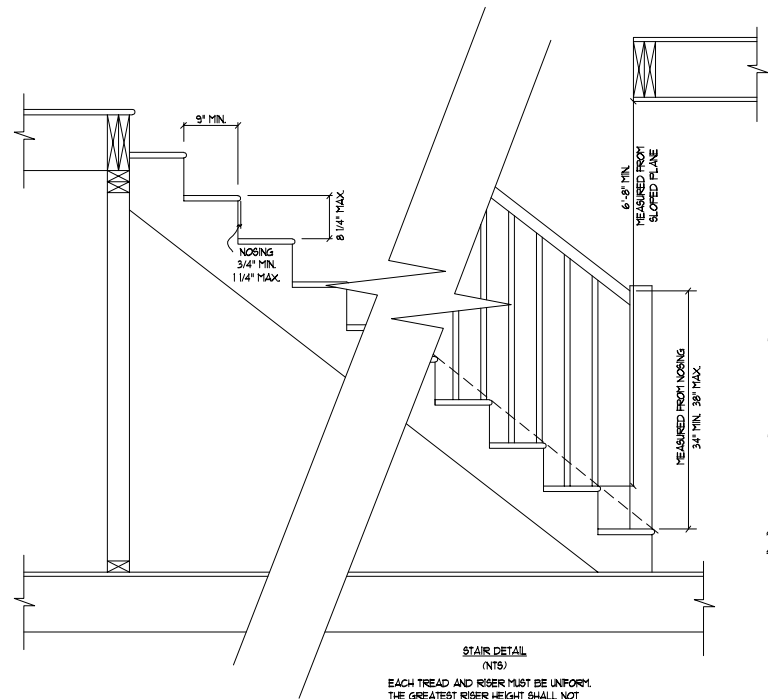

**STAIRS DETAIL (NTS)**  
 EACH TREAD AND RISER MUST BE UNIFORM. THE GREATEST RISER HEIGHT SHALL NOT EXCEED THE SMALLEST BY MORE THAN 3/8\". THE GREATEST TREAD DEPTH SHALL NOT EXCEED THE SMALLEST BY MORE THAN 3/8\". THE TOP AND BOTTOM RISER OF INTERIOR STAIRS SHALL NOT EXCEED THE SMALLEST RISER BY MORE THAN 3/4\". SEE FLOOR PLAN FOR ACTUAL SPECIFICATIONS.

**OPTIONAL TRELLIS KIT**

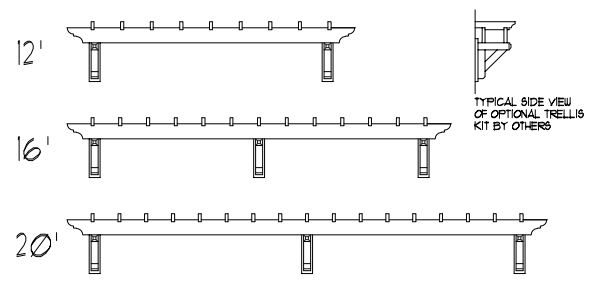

**SCREEN PORCH DECK PANELS**

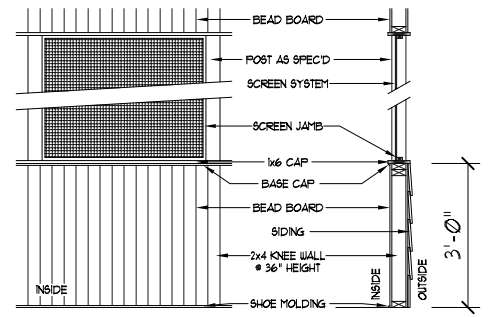

**OPTIONAL BENCH WITH CUBBIES**

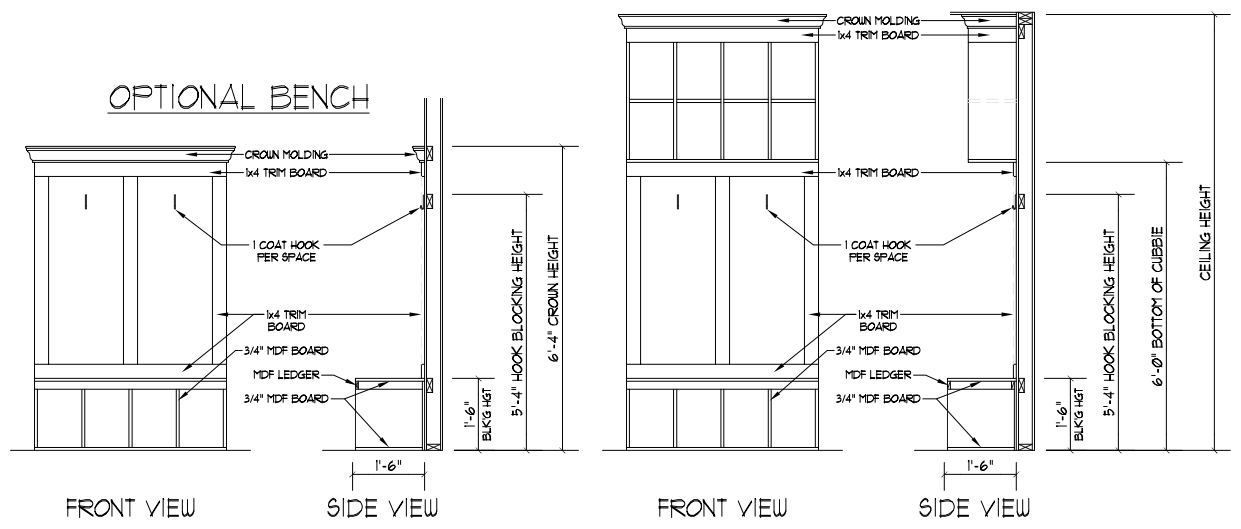

**OPTIONAL BUILT-INS @ FIREPLACE**

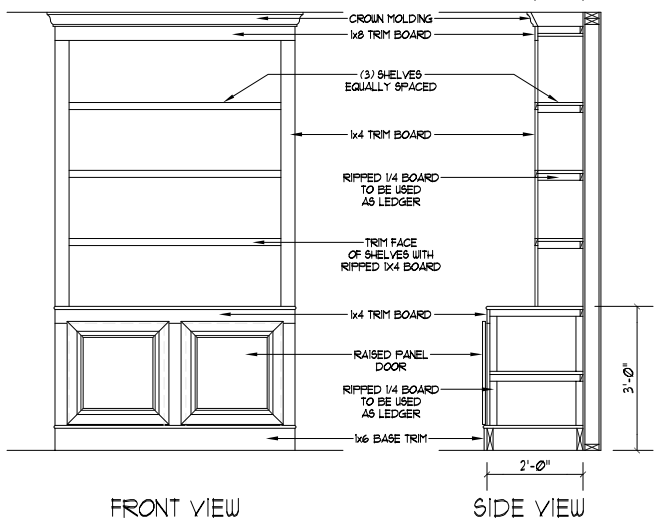

**DROPPED SOFFIT @ PERIMETER**

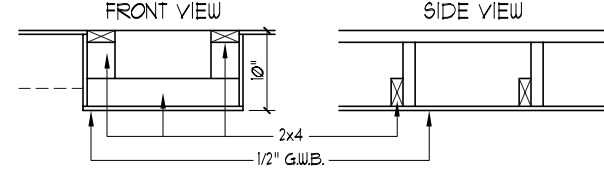

**FAUX BEAM**

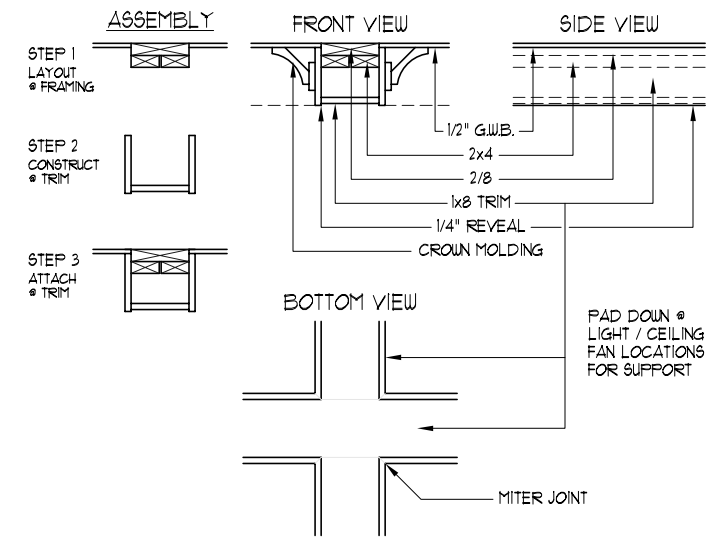

**OPTIONAL BENCH**

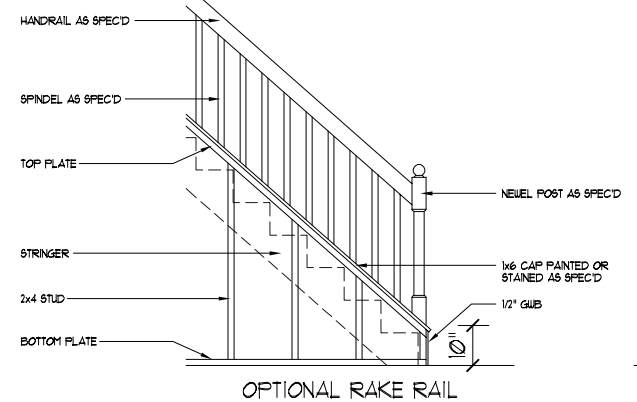
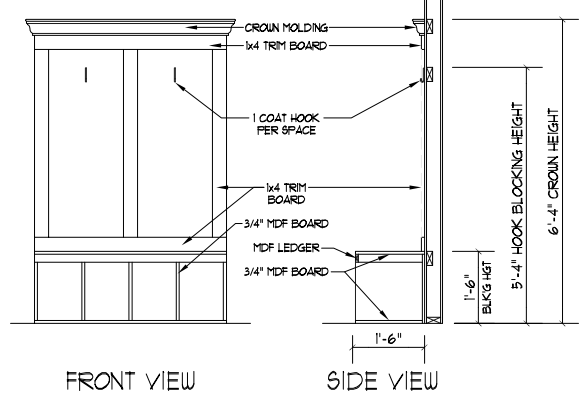

**OPTIONAL RAISED HEARTH WITH STONE**

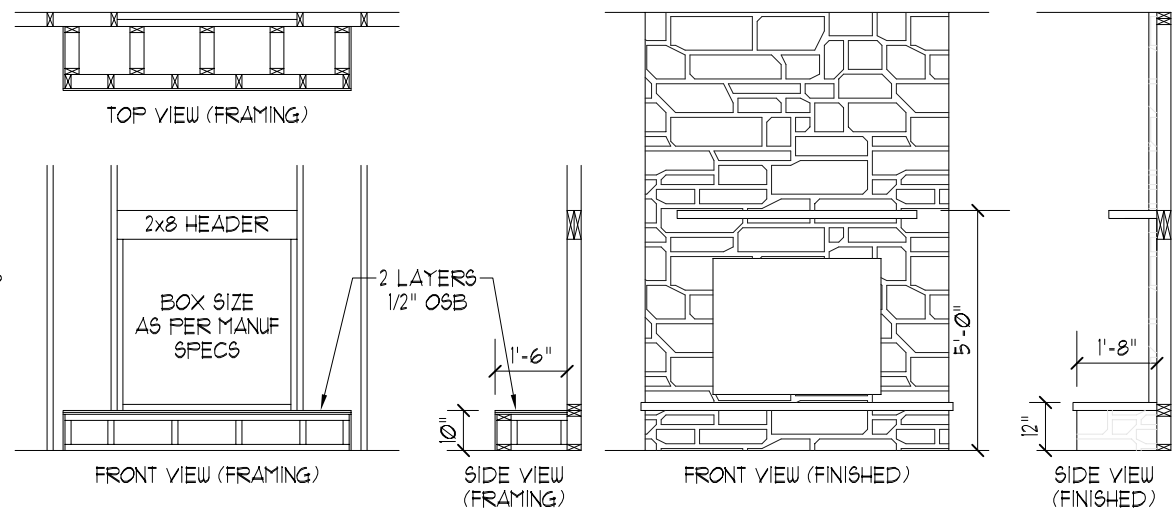

**DYNAMIC DESIGN GROUP, INC**

David D Grorud  
 (919) 601-1406  
 DynamicDesignGroup@gmail.com

The drawings and specifications (plans) contained on these pages are the property of Dynamic Design Group and are offered to the named client or contractor for a conditional one time use. The conditional use is limited to the lot and subdivision specified herein, and only for said location. COPYRIGHT 2021

Contractor shall verify all conditions and dimensions prior to construction. Any error or omissions shall be reported to Dynamic Design Group for corrections or justification. Once construction has commenced, the contractor shall assume all responsibility. Dimensions govern over scale, code governs over dimensions.

CAPITOL PROJECT FOR: CITY HOMES  
 LOCATION: MULTI  
 LOT: MULTI  
 SUBDIVISION: MULTI  
 COUNTY: MULTI

**MIXON III**  
 PLAN NAME  
**B-2287-45GR** 1-28-21 DATE  
 PLAN I.D.  
**D-1B**  
 SHEET