

DATE	9/1/16	UPDATED PER KN REDLINES
REVISION		
BY	AW	

SMITH DOUGLAS HOMES
 110 VILLAGE TRAIL
 SUITE 115
 WOODBRIDGE, VA 20188
 www.smithdouglashomes.com

SMITH DOUGLAS HOMES
 expressly reserves its
 property rights in these plans
 and drawings. These plans
 are to be used for the project
 to be reproduced without
 written consent from SMITH
 DOUGLAS HOMES.

DATE:	6/17/16
PACKAGE QTY:	
PLAN ID:	ALL
FILE:	ALL
REV:	ALL
PROJECT:	D1

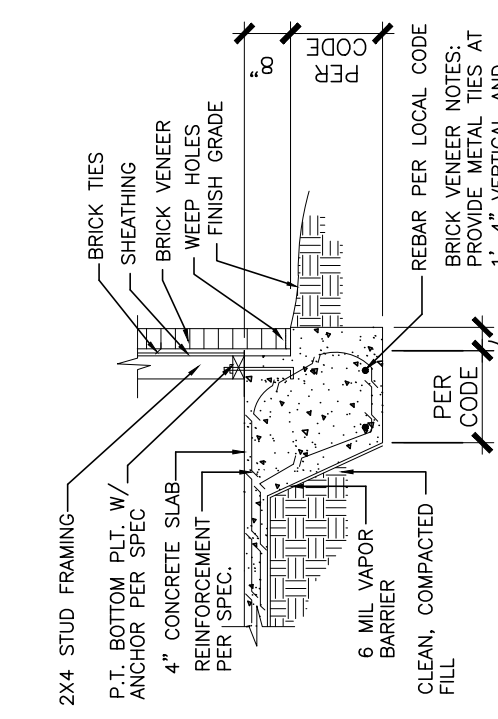

3 SECTION W/ BRICK LEDGE
 N.T.S.

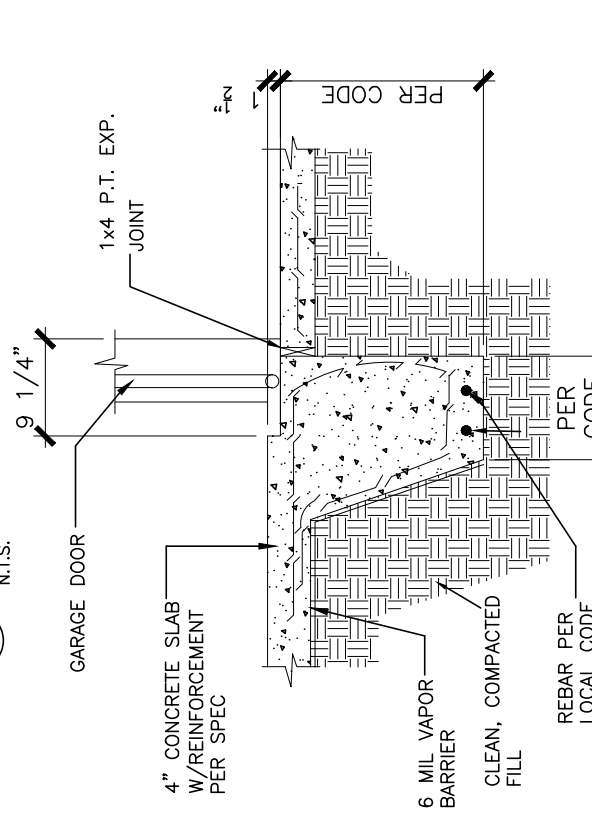

6 TYPICAL GARAGE DOOR DETAIL
 N.T.S.

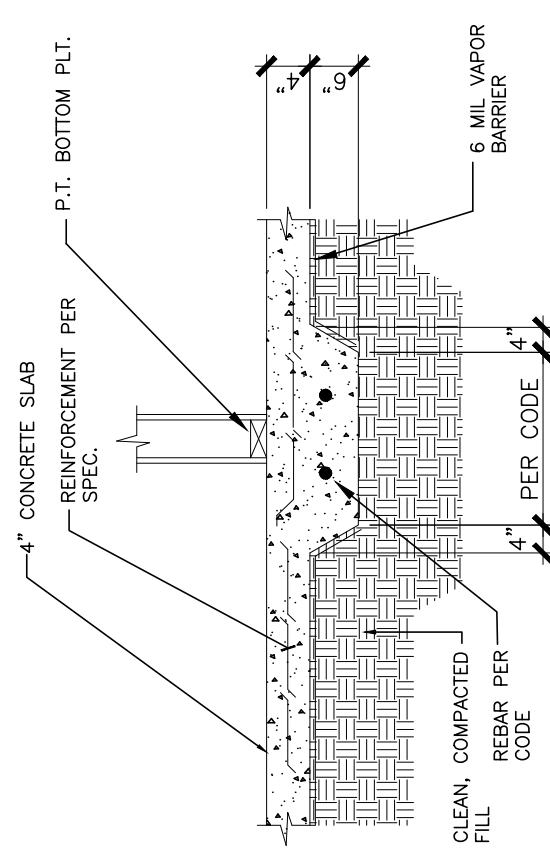

9 SECTION @ GRADE BEAM
 N.T.S.

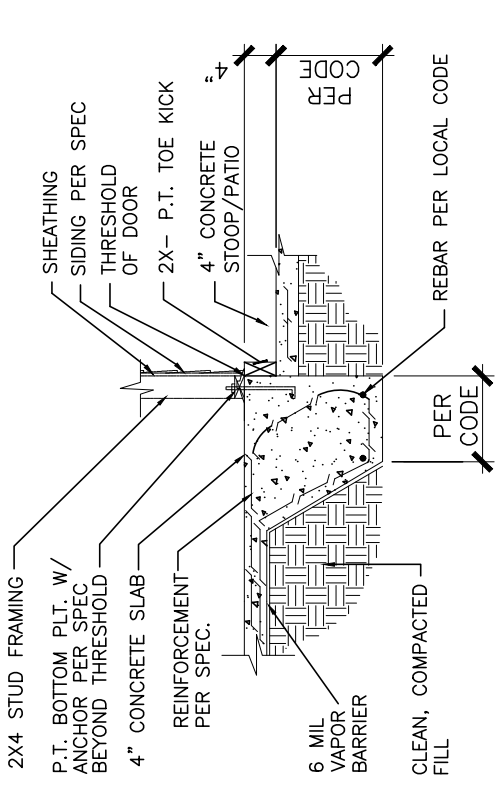

2 SECTION @ PORCH/PATIO
 N.T.S.

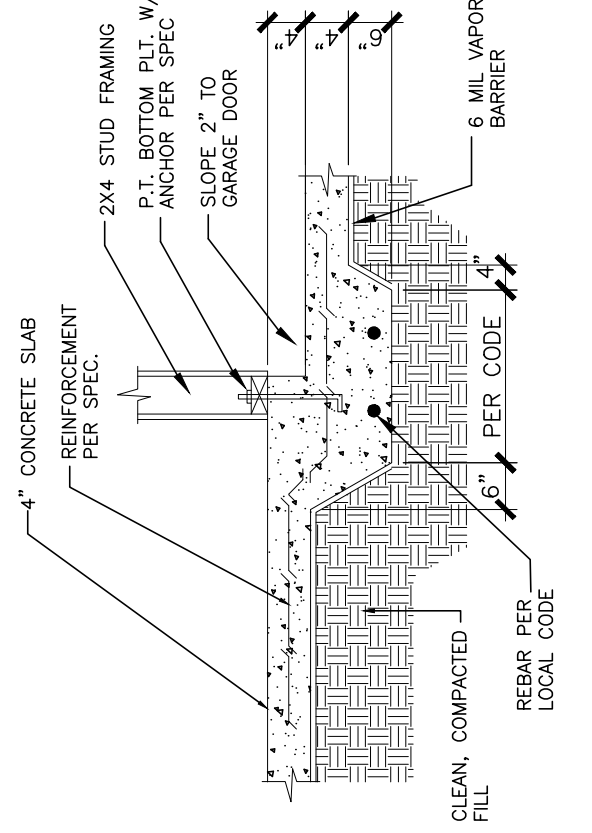

5 SECTION @ GARAGE
 N.T.S.

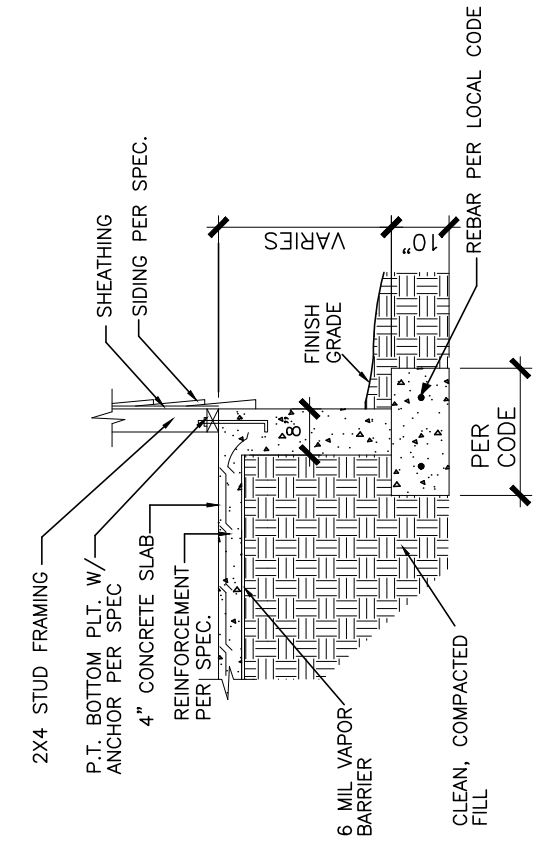

8 TYPICAL STEM WALL DETAIL
 N.T.S.

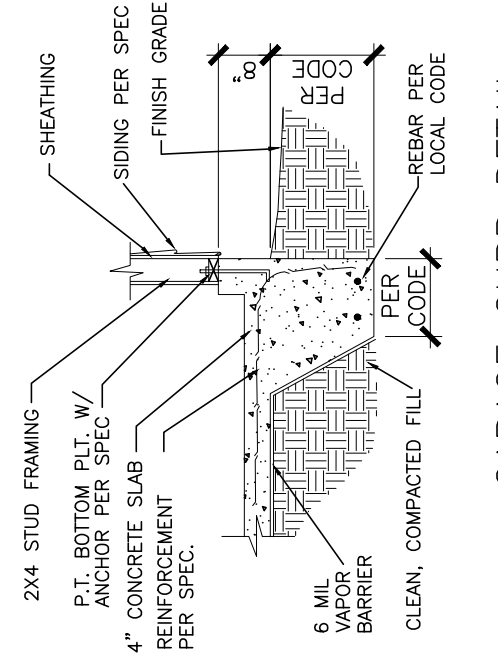

1 GARAGE CURB DETAIL
 N.T.S.

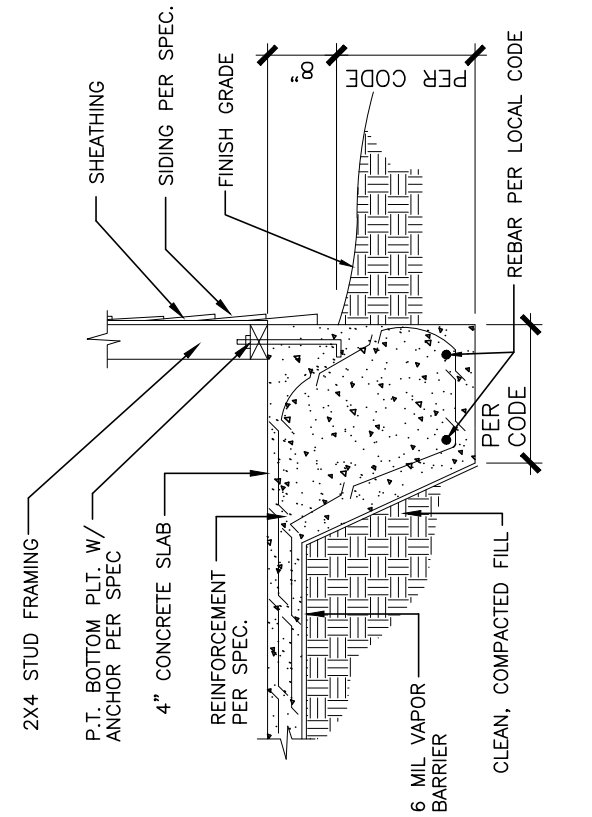

4 TYPICAL SLAB DETAIL
 N.T.S.

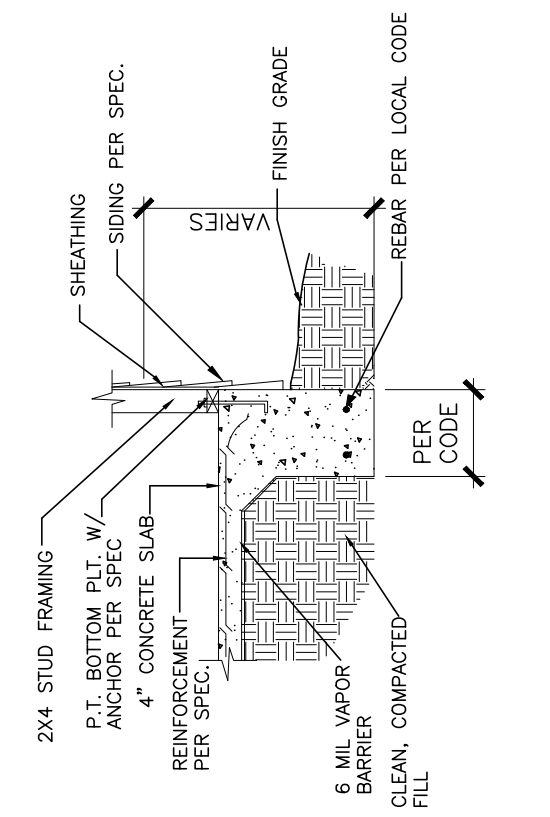

7 TYPICAL TURNDOWN SLAB DETAIL
 N.T.S.