

RE: J0221-0897
Lot 5 Spartan Ridge

Trenco
818 Soundside Rd
Edenton, NC 27932

Site Information:

Customer: Project Name: J0221-0897
Lot/Block: Model:
Address: Subdivision:
City: State:

General Truss Engineering Criteria & Design Loads (Individual Truss Design Drawings Show Special Loading Conditions):

Design Code: IRC2015/TPI2014 Design Program: MiTek 20/20 8.3
Wind Code: N/A Wind Speed: N/A mph
Roof Load: N/A psf Floor Load: 55.0 psf

This package includes 12 individual, dated Truss Design Drawings and 0 Additional Drawings.

No.	Seal#	Truss Name	Date
1	E15028364	ET1	2/23/2021
2	E15028365	ET2	2/23/2021
3	E15028366	F1	2/23/2021
4	E15028367	F2	2/23/2021
5	E15028368	F2A	2/23/2021
6	E15028369	F3	2/23/2021
7	E15028370	F4	2/23/2021
8	E15028371	F5	2/23/2021
9	E15028372	F6	2/23/2021
10	E15028373	F7	2/23/2021
11	E15028374	F7A	2/23/2021
12	E15028375	FG1	2/23/2021

The truss drawing(s) referenced above have been prepared by Truss Engineering Co. under my direct supervision based on the parameters provided by Comtech, Inc - Fayetteville.

Truss Design Engineer's Name: Gilbert, Eric

My license renewal date for the state of North Carolina is December 31, 2021.

North Carolina COA: C-0844

IMPORTANT NOTE: The seal on these truss component designs is a certification that the engineer named is licensed in the jurisdiction(s) identified and that the designs comply with ANSI/TPI 1. These designs are based upon parameters shown (e.g., loads, supports, dimensions, shapes and design codes), which were given to TRENCO. Any project specific information included is for TRENCO customers file reference purpose only, and was not taken into account in the preparation of these designs. TRENCO has not independently verified the applicability of the design parameters or the designs for any particular building. Before use, the building designer should verify applicability of design parameters and properly incorporate these designs into the overall building design per ANSI/TPI 1, Chapter 2.

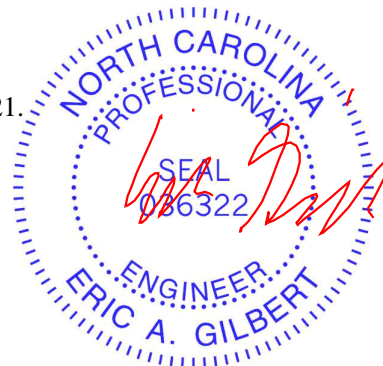

February 23, 2021

Job	Truss	Truss Type	Qty	Ply	Lot 5 Spartan Ridge	E15028364
J0221-0897	ET1	Floor Supported Gable	1	1	Job Reference (optional)	

Comtech, Inc., Fayetteville, NC - 28314,

8.330 s Oct 7 2020 MiTek Industries, Inc. Wed Oct 28 09:07:21 2020 Page 1
ID:Y_aRO?Cxgl9gUrIHW7gHdzqoOe-ltOfOXN38jJhPhfRRo1o?8dghzCY56JswybLyOwta

0'-1'-8"

0'-1'-8"

Scale = 1:18.0

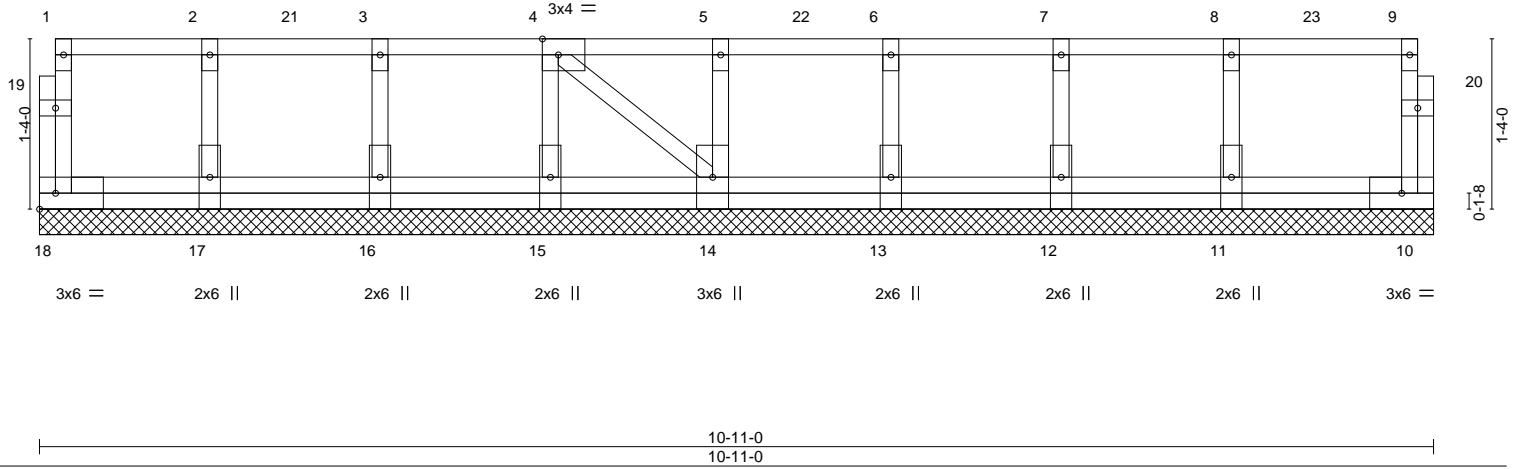

Plate Offsets (X,Y)-- [4:0-1-8,Edge]

LOADING (psf)	SPACING-	2-0-0	CSI.	DEFL.	in (loc)	l/defl	L/d	PLATES	GRIP
TCLL 40.0	Plate Grip DOL	1.00	TC 0.18	Vert(LL)	n/a	-	n/a	MT20	244/190
TCDL 10.0	Lumber DOL	1.00	BC 0.00	Vert(CT)	n/a	-	n/a		
BCLL 0.0	Rep Stress Incr	YES	WB 0.05	Horz(CT)	0.00	10	n/a		
BCDL 5.0	Code IRC2015/TPI2014		Matrix-S					Weight: 66 lb	FT = 20%F, 11%E

LUMBER-
TOP CHORD 2x4 SP No.1(flat)
BOT CHORD 2x4 SP No.1(flat)
WEBS 2x4 SP No.3(flat)
OTHERS 2x4 SP No.3(flat)

BRACING-
TOP CHORD Structural wood sheathing directly applied or 6-0-0 oc purlins, except end verticals.
BOT CHORD Rigid ceiling directly applied or 10-0-0 oc bracing.

REACTIONS. All bearings 10-11-0.
(lb) - Max Grav All reactions 250 lb or less at joint(s) 18, 10, 17, 16, 15, 14, 13, 12, 11

FORCES. (lb) - Max. Comp./Max. Ten. - All forces 250 (lb) or less except when shown.

- NOTES-**
- All plates are 1.5x3 MT20 unless otherwise indicated.
 - Plates checked for a plus or minus 1 degree rotation about its center.
 - Gable requires continuous bottom chord bearing.
 - Truss to be fully sheathed from one face or securely braced against lateral movement (i.e. diagonal web).
 - Gable studs spaced at 1'-4-0 oc.
 - Recommend 2x6 strongbacks, on edge, spaced at 10'-0-0 oc and fastened to each truss with 3-10d (0.131" X 3") nails. Strongbacks to be attached to walls at their outer ends or restrained by other means.

LOAD CASE(S) Standard
1) Dead + Floor Live (balanced): Lumber Increase=1.00, Plate Increase=1.00
Uniform Loads (plf)
Vert: 10-18=-10, 1-9=-100
Concentrated Loads (lb)
Vert: 4=-92 7=-92 21=-92 22=-92 23=-95



October 28, 2020

WARNING - Verify design parameters and READ NOTES ON THIS AND INCLUDED MITEK REFERENCE PAGE MII-7473 rev. 5/19/2020 BEFORE USE.
Design valid for use only with MiTek® connectors. This design is based only upon parameters shown, and is for an individual building component, not a truss system. Before use, the building designer must verify the applicability of design parameters and properly incorporate this design into the overall building design. Bracing indicated is to prevent buckling of individual truss web and/or chord members only. Additional temporary and permanent bracing is always required for stability and to prevent collapse with possible personal injury and property damage. For general guidance regarding the fabrication, storage, delivery, erection and bracing of trusses and truss systems, see **ANSI/TPI1 Quality Criteria, DSB-89 and BCSI Building Component Safety Information** available from Truss Plate Institute, 2670 Crain Highway, Suite 203 Waldorf, MD 20601

ENGINEERING BY
TRENCO
A MiTek Affiliate
818 Soundside Road
Edenton, NC 27932

Job	Truss	Truss Type	Qty	Ply	Lot 5 Spartan Ridge	E15028365
J0221-0897	ET2	Floor Supported Gable	1	1	Job Reference (optional)	

Comtech, Inc., Fayetteville, NC - 28314,

8.330 s Oct 7 2020 MiTek Industries, Inc. Wed Oct 28 09:07:23 2020 Page 1
ID:Y_aRO?Cxglt9gUrlHW7gHdzqoOe-FGWQpxZebiz1x0Z3nsTG6D4W1UNOGSuPmAP3gEyOwtY

0-1-8

0-1-8

Scale = 1:66.9

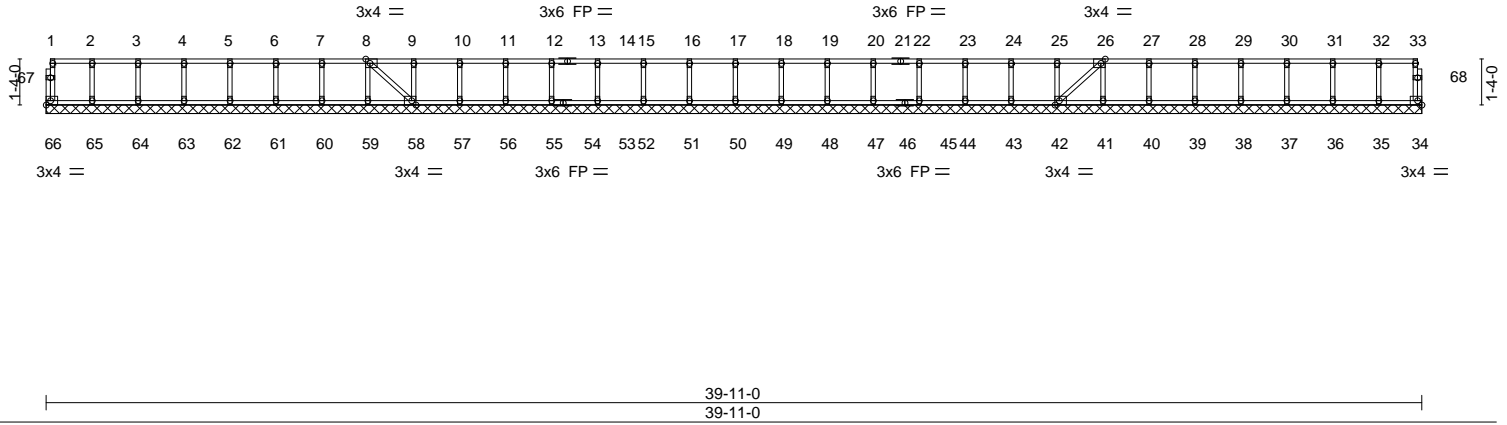

Plate Offsets (X,Y)-- [8:0-1-8,Edge], [26:0-1-8,Edge], [42:0-1-8,Edge], [58:0-1-8,Edge]

LOADING (psf)	SPACING-	CSI.	DEFL.	in (loc)	l/defl	L/d	PLATES	GRIP
TCLL 40.0	Plate Grip DOL 1.00	TC 0.06	Vert(LL) n/a	-	n/a	999	MT20	244/190
TCDL 10.0	Lumber DOL 1.00	BC 0.01	Vert(CT) n/a	-	n/a	999		
BCLL 0.0	Rep Stress Incr YES	WB 0.03	Horz(CT) -0.00	42	n/a	n/a		
BCDL 5.0	Code IRC2015/TPI2014	Matrix-S					Weight: 176 lb	FT = 20%F, 11%E

LUMBER-
TOP CHORD 2x4 SP No.1(flat)
BOT CHORD 2x4 SP No.1(flat)
WEBS 2x4 SP No.3(flat)
OTHERS 2x4 SP No.3(flat)

BRACING-
TOP CHORD Structural wood sheathing directly applied or 6-0-0 oc purlins, except end verticals.
BOT CHORD Rigid ceiling directly applied or 6-0-0 oc bracing.

REACTIONS. All bearings 39-11-0.
(lb) - Max Grav All reactions 250 lb or less at joint(s) 66, 34, 65, 64, 63, 62, 61, 60, 59, 58, 57, 56, 55, 53, 52, 51, 50, 49, 48, 47, 45, 44, 43, 42, 41, 40, 39, 38, 37, 36, 35

FORCES. (lb) - Max. Comp./Max. Ten. - All forces 250 (lb) or less except when shown.

- NOTES-**
- 1) All plates are 1.5x3 MT20 unless otherwise indicated.
 - 2) Plates checked for a plus or minus 1 degree rotation about its center.
 - 3) Gable requires continuous bottom chord bearing.
 - 4) Truss to be fully sheathed from one face or securely braced against lateral movement (i.e. diagonal web).
 - 5) Gable studs spaced at 1-4-0 oc.
 - 6) Recommend 2x6 strongbacks, on edge, spaced at 10-0-0 oc and fastened to each truss with 3-10d (0.131" X 3") nails. Strongbacks to be attached to walls at their outer ends or restrained by other means.



October 28, 2020

WARNING - Verify design parameters and READ NOTES ON THIS AND INCLUDED MITEK REFERENCE PAGE MII-7473 rev. 5/19/2020 BEFORE USE.
Design valid for use only with MiTek® connectors. This design is based only upon parameters shown, and is for an individual building component, not a truss system. Before use, the building designer must verify the applicability of design parameters and properly incorporate this design into the overall building design. Bracing indicated is to prevent buckling of individual truss web and/or chord members only. Additional temporary and permanent bracing is always required for stability and to prevent collapse with possible personal injury and property damage. For general guidance regarding the fabrication, storage, delivery, erection and bracing of trusses and truss systems, see **ANSI/TPI1 Quality Criteria, DSB-89 and BCSI Building Component Safety Information** available from Truss Plate Institute, 2670 Crain Highway, Suite 203 Waldorf, MD 20601

ENGINEERING BY
TRENCO
A MiTek Affiliate
818 Soundside Road
Edenton, NC 27932

Job	Truss	Truss Type	Qty	Ply	Lot 5 Spartan Ridge	E15028366
J0221-0897	F1	Floor	4	1	Job Reference (optional)	

Comtech, Inc., Fayetteville, NC - 28314,

8.330 s Oct 7 2020 MiTek Industries, Inc. Wed Oct 28 09:07:24 2020 Page 1
ID:Y_aRO?Cxglt9gUrhHW7gHdzqoOe-jS4o0GZGM35uYA8GLZ_VeQdcmuedPr3Y?q8cCgyOwtX

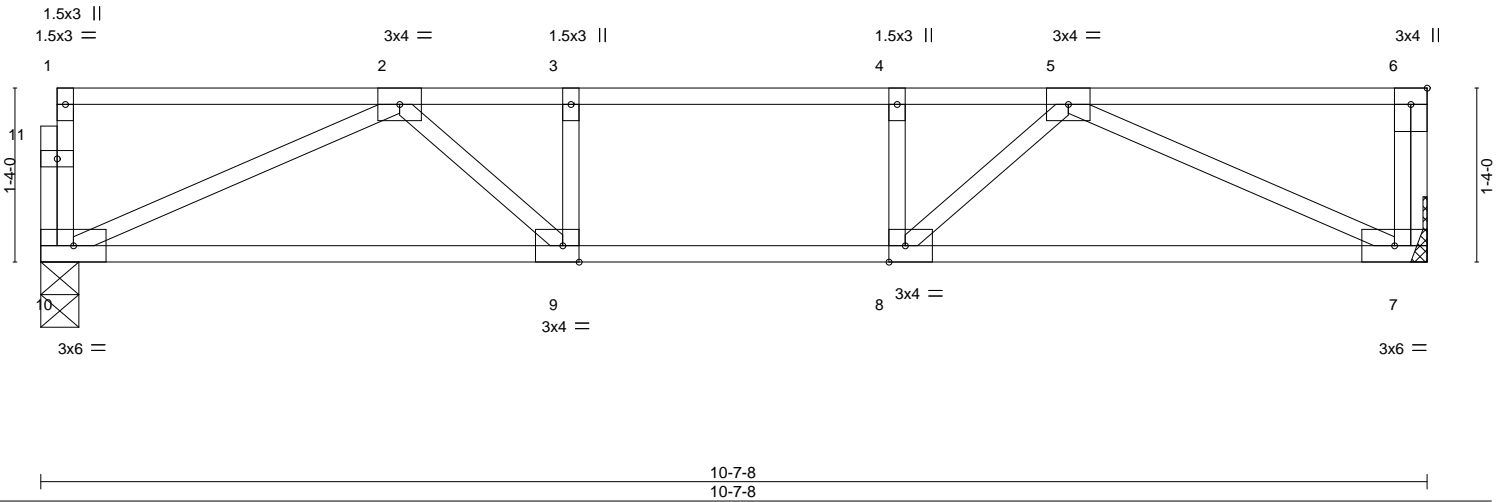
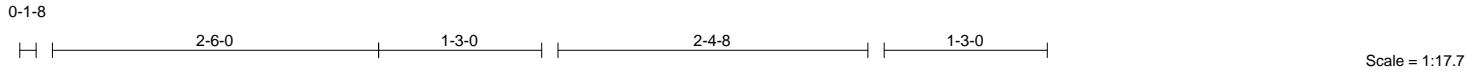

Plate Offsets (X,Y)-- [8:0-1-8,Edge], [9:0-1-8,Edge]

LOADING (psf)	SPACING-	2-0-0	CSI.	DEFL.	in (loc)	l/defl	L/d	PLATES	GRIP	
TCLL 40.0	Plate Grip DOL	1.00	TC 0.38	Vert(LL)	-0.07	9-10	>999	480	MT20	244/190
TCDL 10.0	Lumber DOL	1.00	BC 0.33	Vert(CT)	-0.10	9-10	>999	360		
BCLL 0.0	Rep Stress Incr	YES	WB 0.29	Horz(CT)	0.02	7	n/a	n/a		
BCDL 5.0	Code	IRC2015/TPI2014	Matrix-S							
									Weight: 54 lb	FT = 20%F, 11%E

LUMBER-
TOP CHORD 2x4 SP No.1(flat)
BOT CHORD 2x4 SP No.1(flat)
WEBS 2x4 SP No.3(flat)

BRACING-
TOP CHORD Structural wood sheathing directly applied or 6-0-0 oc purlins, except end verticals.
BOT CHORD Rigid ceiling directly applied or 10-0-0 oc bracing.

REACTIONS. (size) 10=0-3-8, 7=Mechanical
Max Grav 10=564(LC 1), 7=571(LC 1)

FORCES. (lb) - Max. Comp./Max. Ten. - All forces 250 (lb) or less except when shown.

TOP CHORD 2-3=-1188/0, 3-4=-1188/0, 4-5=-1188/0
BOT CHORD 9-10=0/958, 8-9=0/1188, 7-8=0/961
WEBS 2-10=-1048/0, 5-7=-1057/0, 5-8=0/454, 2-9=0/455

- NOTES-**
- 1) Unbalanced floor live loads have been considered for this design.
 - 2) Plates checked for a plus or minus 1 degree rotation about its center.
 - 3) Refer to girder(s) for truss to truss connections.
 - 4) Recommend 2x6 strongbacks, on edge, spaced at 10-0-0 oc and fastened to each truss with 3-10d (0.131" X 3") nails. Strongbacks to be attached to walls at their outer ends or restrained by other means.
 - 5) CAUTION, Do not erect truss backwards.



October 28, 2020

WARNING - Verify design parameters and READ NOTES ON THIS AND INCLUDED MITEK REFERENCE PAGE MII-7473 rev. 5/19/2020 BEFORE USE.

Design valid for use only with MiTek® connectors. This design is based only upon parameters shown, and is for an individual building component, not a truss system. Before use, the building designer must verify the applicability of design parameters and properly incorporate this design into the overall building design. Bracing indicated is to prevent buckling of individual truss web and/or chord members only. Additional temporary and permanent bracing is always required for stability and to prevent collapse with possible personal injury and property damage. For general guidance regarding the fabrication, storage, delivery, erection and bracing of trusses and truss systems, see

ANSI/TPI1 Quality Criteria, DSB-89 and BCSI Building Component

Safety Information available from Truss Plate Institute, 2670 Crain Highway, Suite 203 Waldorf, MD 20601



818 Soundside Road
Edenton, NC 27932

Job	Truss	Truss Type	Qty	Ply	Lot 5 Spartan Ridge	E15028367
J0221-0897	F2	Floor	2	1	Job Reference (optional)	

Comtech, Inc, Fayetteville, NC - 28314,

8.330 s Oct 7 2020 MiTek Industries, Inc. Wed Oct 28 09:07:25 2020 Page 1
ID:Y_aRO?Cxglt9gUrIHW7gHdzqoOe-BedAEcau7NEIAKjSuGvkBeAkVIt78EHIEUuAk6yOwtW

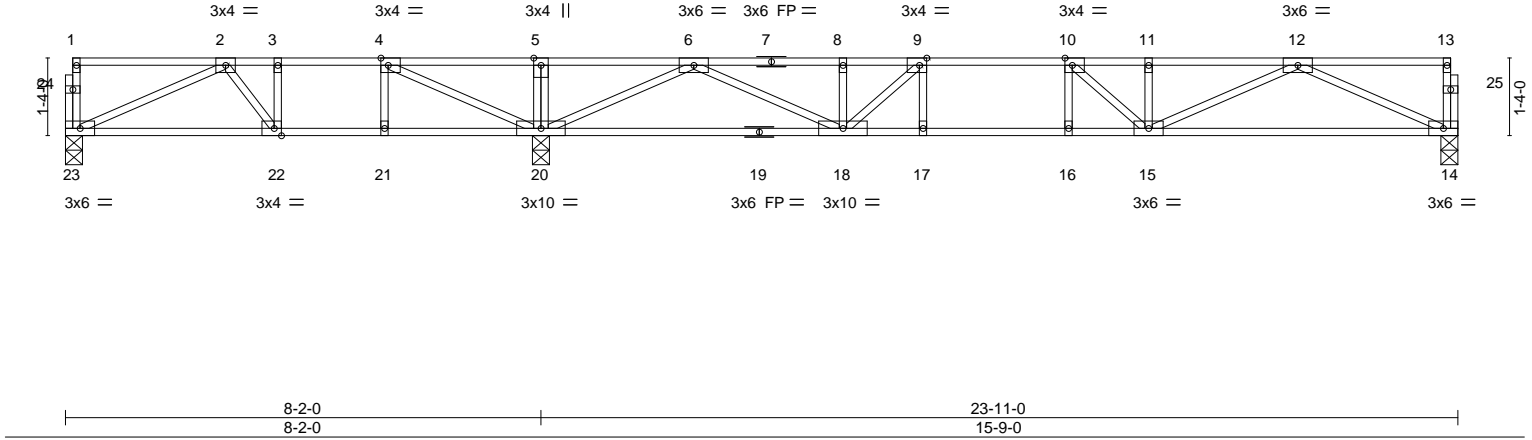

LOADING (psf)	SPACING-	CSI.	DEFL.	PLATES	GRIP
TCLL 40.0	2-0-0	TC 0.57	in (loc) l/defl L/d	MT20	244/190
TCDL 10.0	Plate Grip DOL 1.00	BC 0.76	Vert(LL) -0.17 15-16 >999 480		
BCLL 0.0	Lumber DOL 1.00	WB 0.55	Vert(CT) -0.22 15-16 >838 360		
BCDL 5.0	Rep Stress Incr YES	Matrix-S	Horz(CT) 0.04 14 n/a n/a		
	Code IRC2015/TPI2014			Weight: 121 lb	FT = 20%F, 11%E

LUMBER-	BRACING-
TOP CHORD 2x4 SP No.1(flat)	TOP CHORD Structural wood sheathing directly applied or 6-0-0 oc purlins, except end verticals.
BOT CHORD 2x4 SP No.1(flat)	BOT CHORD Rigid ceiling directly applied or 6-0-0 oc bracing.
WEBS 2x4 SP No.3(flat)	

REACTIONS. (size) 23=0-3-8, 20=0-3-8, 14=0-3-8
Max Grav 23=399(LC 3), 20=1476(LC 1), 14=807(LC 7)

FORCES. (lb) - Max. Comp./Max. Ten. - All forces 250 (lb) or less except when shown.
TOP CHORD 2-3=-576/210, 3-4=-576/210, 4-5=0/819, 5-6=0/819, 6-8=-2093/0, 8-9=-2093/0, 9-10=-2436/0, 10-11=-2309/0, 11-12=-2309/0
BOT CHORD 22-23=-67/604, 21-22=-210/576, 20-21=-210/576, 18-20=0/1100, 17-18=0/2436, 16-17=0/2436, 15-16=0/2436, 14-15=0/1491
WEBS 5-20=-251/0, 2-23=-659/75, 4-20=-1113/0, 2-22=-273/0, 6-20=-1846/0, 6-18=0/1156, 12-14=-1636/0, 12-15=0/904, 11-15=-251/25, 10-15=-400/107, 9-18=-679/0

- NOTES-**
- 1) Unbalanced floor live loads have been considered for this design.
 - 2) All plates are 1.5x3 MT20 unless otherwise indicated.
 - 3) Plates checked for a plus or minus 1 degree rotation about its center.
 - 4) Recommend 2x6 strongbacks, on edge, spaced at 10-0-0 oc and fastened to each truss with 3-10d (0.131" X 3") nails. Strongbacks to be attached to walls at their outer ends or restrained by other means.
 - 5) CAUTION, Do not erect truss backwards.



October 28, 2020

WARNING - Verify design parameters and READ NOTES ON THIS AND INCLUDED MITEK REFERENCE PAGE MII-7473 rev. 5/19/2020 BEFORE USE.
Design valid for use only with MiTek® connectors. This design is based only upon parameters shown, and is for an individual building component, not a truss system. Before use, the building designer must verify the applicability of design parameters and properly incorporate this design into the overall building design. Bracing indicated is to prevent buckling of individual truss web and/or chord members only. Additional temporary and permanent bracing is always required for stability and to prevent collapse with possible personal injury and property damage. For general guidance regarding the fabrication, storage, delivery, erection and bracing of trusses and truss systems, see **ANSI/TPI1 Quality Criteria, DSB-89 and BCSI Building Component Safety Information** available from Truss Plate Institute, 2670 Crain Highway, Suite 203 Waldorf, MD 20601

ENGINEERING BY
TRENCO
A MiTek Affiliate
818 Soundside Road
Edenton, NC 27932

Job	Truss	Truss Type	Qty	Ply	Lot 5 Spartan Ridge	E15028368
J0221-0897	F2A	Floor	1	1	Job Reference (optional)	

Comtech, Inc., Fayetteville, NC - 28314,

8.330 s Oct 7 2020 MiTek Industries, Inc. Wed Oct 28 09:07:27 2020 Page 1
ID:Y_aRO?Cxlgt9UrHW7gHdzqoOe-71lwfic8f_UTPetr0hYCG3F6e5fMc4R?hnNGp?yOwtU

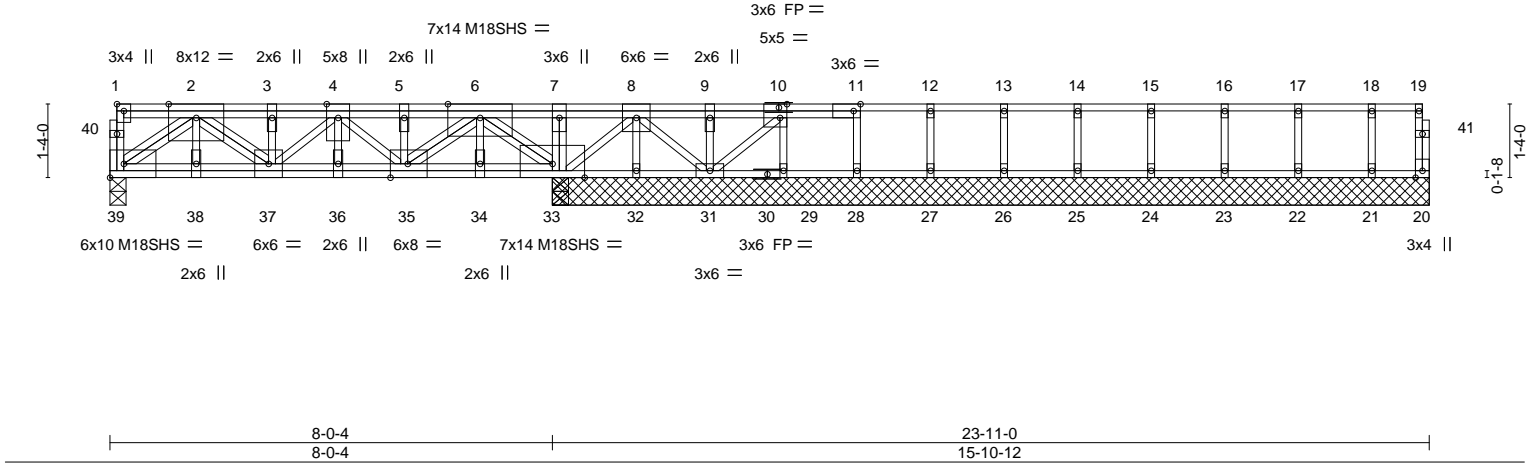
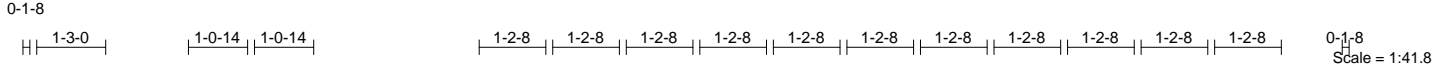

LOADING (psf)	SPACING-	CSL	DEFL.	in (loc)	l/defl	L/d	PLATES	GRIP
TCLL 40.0	Plate Grip DOL 1.00	TC 0.40	Vert(LL) -0.03	36	>999	480	MT20	244/190
TCDL 10.0	Lumber DOL 1.00	BC 0.32	Vert(CT) -0.06	36	>999	360	M18SHS	244/190
BCLL 0.0	Rep Stress Incr NO	WB 0.83	Horz(CT) 0.01	33	n/a	n/a		
BCDL 5.0	Code IRC2015/TPI2014	Matrix-S						
							Weight: 163 lb	FT = 20%F, 11%E

LUMBER-
TOP CHORD 2x4 SP 2400F 2.0E(flat)
BOT CHORD 2x4 SP 2400F 2.0E(flat)
WEBS 2x4 SP No.3(flat)

BRACING-
TOP CHORD Structural wood sheathing directly applied or 6-0-0 oc purlins, except end verticals.
BOT CHORD Rigid ceiling directly applied or 10-0-0 oc bracing, Except: 6-0-0 oc bracing: 32-33,31-32.

REACTIONS. All bearings 15-10-12 except (jt=length) 39=0-3-8.
(lb) - Max Grav All reactions 250 lb or less at joint(s) except 39=3198(LC 1), 20=266(LC 1), 33=6051(LC 1), 33=6051(LC 1), 32=470(LC 1), 31=1404(LC 1), 29=648(LC 1), 28=1270(LC 1), 27=1238(LC 1), 26=1241(LC 1), 25=1239(LC 1), 24=1242(LC 1), 23=1232(LC 1), 22=1270(LC 1), 21=1125(LC 1)

FORCES. (lb) - Max. Comp./Max. Ten. - All forces 250 (lb) or less except when shown.
TOP CHORD 1-39=-520/0, 19-20=-264/0, 2-3=-5006/0, 3-4=-5068/0, 4-5=-4015/0, 5-6=-3949/0, 6-7=0/2814, 7-8=0/2639, 8-9=0/628, 9-10=0/628
BOT CHORD 38-39=0/3531, 37-38=0/3531, 36-37=0/5150, 35-36=0/5150, 34-35=0/1265, 33-34=0/1265, 32-33=-1102/0, 31-32=-1102/0
WEBS 7-33=-1527/0, 2-39=-4385/0, 2-37=0/1912, 3-37=-1098/0, 6-33=-5289/0, 6-35=0/3479, 5-35=-1167/0, 8-33=-1887/0, 8-32=-462/0, 8-31=0/625, 9-31=-1151/0, 10-31=-934/0, 10-29=-640/0, 11-28=-1255/0, 12-27=-1225/0, 13-26=-1227/0, 14-25=-1226/0, 15-24=-1229/0, 16-23=-1219/0, 17-22=-1257/0, 18-21=-1112/0, 4-35=-1498/0

- NOTES-**
- Unbalanced floor live loads have been considered for this design.
 - All plates are MT20 plates unless otherwise indicated.
 - All plates are 1.5x3 MT20 unless otherwise indicated.
 - The Fabrication Tolerance at joint 28 = 3%, joint 27 = 3%, joint 12 = 3%, joint 26 = 3%, joint 13 = 3%, joint 25 = 3%, joint 14 = 3%, joint 24 = 3%, joint 15 = 3%, joint 23 = 7%, joint 16 = 7%, joint 22 = 3%, joint 17 = 3%
 - Plates checked for a plus or minus 1 degree rotation about its center.
 - Load case(s) 1, 2, 3, 4, 5, 6, 7, 8, 9, 10, 11, 12, 13, 14, 15, 16, 17, 18, 19, 20, 21, 22, 23, 24, 25, 26, 27, 28, 29, 30, 31, 32, 33, 34, 35, 36, 37, 38 has/have been modified. Building designer must review loads to verify that they are correct for the intended use of this truss.
 - Recommend 2x6 strongbacks, on edge, spaced at 10-0-0 oc and fastened to each truss with 3-10d (0.131" X 3") nails. Strongbacks to be attached to walls at their outer ends or restrained by other means.
 - CAUTION, Do not erect truss backwards.

LOAD CASE(S) Standard Except:
1) Dead + Floor Live (balanced): Lumber Increase=1.00, Plate Increase=1.00
Uniform Loads (plf)
Vert: 20-39=-10, 1-19=-920
2) Dead: Lumber Increase=1.00, Plate Increase=1.00



October 28, 2020

Job	Truss	Truss Type	Qty	Ply	Lot 5 Spartan Ridge	E15028368
J0221-0897	F2A	Floor	1	1	Job Reference (optional)	

Comtech, Inc., Fayetteville, NC - 28314,

8.330 s Oct 7 2020 MiTek Industries, Inc. Wed Oct 28 09:07:28 2020 Page 2
 ID:Y_aRO?CxglT9gUrhHW7gHdzqoOe-bDJIsedmQlck1oS1aP3RpGoHOV?bLXh8wR7qLRyOwt

LOAD CASE(S) Standard

- Uniform Loads (plf)
 - Vert: 20-39=-10, 1-19=-570
- 3) 1st chase Dead + Floor Live (unbalanced): Lumber Increase=1.00, Plate Increase=1.00
 - Uniform Loads (plf)
 - Vert: 20-39=-10, 1-19=-570
- 4) 2nd chase Dead + Floor Live (unbalanced): Lumber Increase=1.00, Plate Increase=1.00
 - Uniform Loads (plf)
 - Vert: 20-39=-10, 1-19=-570
- 5) 3rd chase Dead + Floor Live (unbalanced): Lumber Increase=1.00, Plate Increase=1.00
 - Uniform Loads (plf)
 - Vert: 20-39=-10, 1-19=-570
- 6) 4th chase Dead + Floor Live (unbalanced): Lumber Increase=1.00, Plate Increase=1.00
 - Uniform Loads (plf)
 - Vert: 20-39=-10, 1-19=-570
- 7) 5th chase Dead + Floor Live (unbalanced): Lumber Increase=1.00, Plate Increase=1.00
 - Uniform Loads (plf)
 - Vert: 20-39=-10, 1-19=-570
- 8) 6th chase Dead + Floor Live (unbalanced): Lumber Increase=1.00, Plate Increase=1.00
 - Uniform Loads (plf)
 - Vert: 20-39=-10, 1-19=-570
- 9) 7th chase Dead + Floor Live (unbalanced): Lumber Increase=1.00, Plate Increase=1.00
 - Uniform Loads (plf)
 - Vert: 20-39=-10, 1-19=-570
- 10) 8th chase Dead + Floor Live (unbalanced): Lumber Increase=1.00, Plate Increase=1.00
 - Uniform Loads (plf)
 - Vert: 20-39=-10, 1-19=-570
- 11) 9th chase Dead + Floor Live (unbalanced): Lumber Increase=1.00, Plate Increase=1.00
 - Uniform Loads (plf)
 - Vert: 20-39=-10, 1-19=-570
- 12) 10th chase Dead + Floor Live (unbalanced): Lumber Increase=1.00, Plate Increase=1.00
 - Uniform Loads (plf)
 - Vert: 20-39=-10, 1-19=-570
- 13) 11th chase Dead + Floor Live (unbalanced): Lumber Increase=1.00, Plate Increase=1.00
 - Uniform Loads (plf)
 - Vert: 20-39=-10, 1-19=-570
- 14) 12th chase Dead + Floor Live (unbalanced): Lumber Increase=1.00, Plate Increase=1.00
 - Uniform Loads (plf)
 - Vert: 20-39=-10, 1-19=-570
- 15) 13th chase Dead + Floor Live (unbalanced): Lumber Increase=1.00, Plate Increase=1.00
 - Uniform Loads (plf)
 - Vert: 20-39=-10, 1-19=-570
- 16) 14th chase Dead + Floor Live (unbalanced): Lumber Increase=1.00, Plate Increase=1.00
 - Uniform Loads (plf)
 - Vert: 20-39=-10, 1-19=-570
- 17) 15th chase Dead + Floor Live (unbalanced): Lumber Increase=1.00, Plate Increase=1.00
 - Uniform Loads (plf)
 - Vert: 20-39=-10, 1-19=-570
- 18) 16th chase Dead + Floor Live (unbalanced): Lumber Increase=1.00, Plate Increase=1.00
 - Uniform Loads (plf)
 - Vert: 20-39=-10, 1-19=-570
- 19) 17th chase Dead + Floor Live (unbalanced): Lumber Increase=1.00, Plate Increase=1.00
 - Uniform Loads (plf)
 - Vert: 20-39=-10, 1-19=-570
- 20) 18th chase Dead + Floor Live (unbalanced): Lumber Increase=1.00, Plate Increase=1.00
 - Uniform Loads (plf)
 - Vert: 20-39=-10, 1-19=-570
- 21) 19th chase Dead: Lumber Increase=1.00, Plate Increase=1.00
 - Uniform Loads (plf)
 - Vert: 20-39=-10, 1-19=-570
- 22) 20th chase Dead: Lumber Increase=1.00, Plate Increase=1.00
 - Uniform Loads (plf)
 - Vert: 20-39=-10, 1-19=-570
- 23) 21st chase Dead: Lumber Increase=1.00, Plate Increase=1.00
 - Uniform Loads (plf)
 - Vert: 20-39=-10, 1-19=-570
- 24) 22nd chase Dead: Lumber Increase=1.00, Plate Increase=1.00
 - Uniform Loads (plf)
 - Vert: 20-39=-10, 1-19=-570
- 25) 23rd chase Dead: Lumber Increase=1.00, Plate Increase=1.00
 - Uniform Loads (plf)
 - Vert: 20-39=-10, 1-19=-570
- 26) 24th chase Dead: Lumber Increase=1.00, Plate Increase=1.00
 - Uniform Loads (plf)
 - Vert: 20-39=-10, 1-19=-570
- 27) 25th chase Dead: Lumber Increase=1.00, Plate Increase=1.00

Continued on page 3

WARNING - Verify design parameters and READ NOTES ON THIS AND INCLUDED MITEK REFERENCE PAGE MII-7473 rev. 5/19/2020 BEFORE USE.

Design valid for use only with MiTek® connectors. This design is based only upon parameters shown, and is for an individual building component, not a truss system. Before use, the building designer must verify the applicability of design parameters and properly incorporate this design into the overall building design. Bracing indicated is to prevent buckling of individual truss web and/or chord members only. Additional temporary and permanent bracing is always required for stability and to prevent collapse with possible personal injury and property damage. For general guidance regarding the fabrication, storage, delivery, erection and bracing of trusses and truss systems, see **ANSI/TPI1 Quality Criteria, DSB-89 and BCSI Building Component**

Safety Information available from Truss Plate Institute, 2670 Crain Highway, Suite 203 Waldorf, MD 20601



818 Soundside Road
 Edenton, NC 27932

Job	Truss	Truss Type	Qty	Ply	Lot 5 Spartan Ridge	E15028368
J0221-0897	F2A	Floor	1	1	Job Reference (optional)	

Comtech, Inc, Fayetteville, NC - 28314,

8.330 s Oct 7 2020 MiTek Industries, Inc. Wed Oct 28 09:07:28 2020 Page 3
 ID:Y_aRO?Cxglt9gUrhHW7gHdzqoOe-bDJIsedmQlck1oS1aP3RpGoHOV?bLXh8wR7qLRyOwtT

LOAD CASE(S) Standard

- Uniform Loads (plf)
 - Vert: 20-39=-10, 1-19=-570
- 28) 26th chase Dead: Lumber Increase=1.00, Plate Increase=1.00
 - Uniform Loads (plf)
 - Vert: 20-39=-10, 1-19=-570
- 29) 27th chase Dead: Lumber Increase=1.00, Plate Increase=1.00
 - Uniform Loads (plf)
 - Vert: 20-39=-10, 1-19=-570
- 30) 28th chase Dead: Lumber Increase=1.00, Plate Increase=1.00
 - Uniform Loads (plf)
 - Vert: 20-39=-10, 1-19=-570
- 31) 29th chase Dead: Lumber Increase=1.00, Plate Increase=1.00
 - Uniform Loads (plf)
 - Vert: 20-39=-10, 1-19=-570
- 32) 30th chase Dead: Lumber Increase=1.00, Plate Increase=1.00
 - Uniform Loads (plf)
 - Vert: 20-39=-10, 1-19=-570
- 33) 31st chase Dead: Lumber Increase=1.00, Plate Increase=1.00
 - Uniform Loads (plf)
 - Vert: 20-39=-10, 1-19=-570
- 34) 32nd chase Dead: Lumber Increase=1.00, Plate Increase=1.00
 - Uniform Loads (plf)
 - Vert: 20-39=-10, 1-19=-570
- 35) 33rd chase Dead: Lumber Increase=1.00, Plate Increase=1.00
 - Uniform Loads (plf)
 - Vert: 20-39=-10, 1-19=-570
- 36) 34th chase Dead: Lumber Increase=1.00, Plate Increase=1.00
 - Uniform Loads (plf)
 - Vert: 20-39=-10, 1-19=-570
- 37) 35th chase Dead: Lumber Increase=1.00, Plate Increase=1.00
 - Uniform Loads (plf)
 - Vert: 20-39=-10, 1-19=-570
- 38) 36th chase Dead: Lumber Increase=1.00, Plate Increase=1.00
 - Uniform Loads (plf)
 - Vert: 20-39=-10, 1-19=-570

WARNING - Verify design parameters and READ NOTES ON THIS AND INCLUDED MITEK REFERENCE PAGE MII-7473 rev. 5/19/2020 BEFORE USE.

Design valid for use only with MiTek® connectors. This design is based only upon parameters shown, and is for an individual building component, not a truss system. Before use, the building designer must verify the applicability of design parameters and properly incorporate this design into the overall building design. Bracing indicated is to prevent buckling of individual truss web and/or chord members only. Additional temporary and permanent bracing is always required for stability and to prevent collapse with possible personal injury and property damage. For general guidance regarding the fabrication, storage, delivery, erection and bracing of trusses and truss systems, see **ANSI/TPI1 Quality Criteria, DSB-89 and BCSI Building Component Safety Information** available from Truss Plate Institute, 2670 Crain Highway, Suite 203 Waldorf, MD 20601



818 Soundside Road
 Edenton, NC 27932

Job	Truss	Truss Type	Qty	Ply	Lot 5 Spartan Ridge	E15028369
J0221-0897	F3	Floor Girder	1	1	Job Reference (optional)	

Comtech, Inc., Fayetteville, NC - 28314,

8.330 s Oct 7 2020 MiTek Industries, Inc. Wed Oct 28 09:07:29 2020 Page 1
ID:Y_aRO?CxglT9gUrHW7gHdzqoOe-3QtH3_dOBbkBfx1D76agLUKOSvDX4xFH95sNtTyOwtS

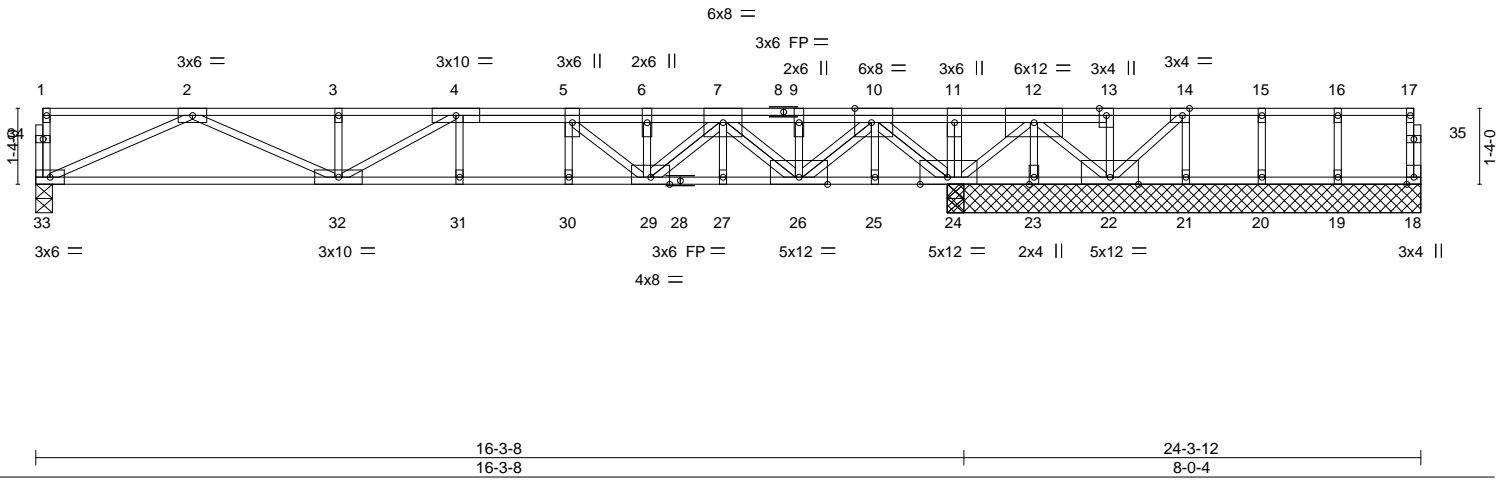

LOADING (psf)	SPACING-	CSL	DEFL.	PLATES	GRIP
TCLL 40.0	Plate Grip DOL 1.00	TC 0.70	Vert(LL) -0.15 30 >999 480	MT20	244/190
TCDL 10.0	Lumber DOL 1.00	BC 0.86	Vert(CT) -0.21 30 >903 360		
BCLL 0.0	Rep Stress Incr NO	WB 1.00	Horz(CT) 0.03 24 n/a n/a		
BCDL 5.0	Code IRC2015/TPI2014	Matrix-S			
				Weight: 155 lb	FT = 20%F, 11%E

LUMBER-
TOP CHORD 2x4 SP No.1(flat)
BOT CHORD 2x4 SP No.1(flat)
WEBS 2x4 SP No.3(flat)

BRACING-
TOP CHORD Structural wood sheathing directly applied or 6-0-0 oc purlins, except end verticals.
BOT CHORD Rigid ceiling directly applied or 10-0-0 oc bracing, Except: 6-0-0 oc bracing: 25-26,24-25,23-24,22-23.

REACTIONS. All bearings 8-3-12 except (jt=length) 33=0-3-8.
(lb) - Max Uplift All uplift 100 lb or less at joint(s) except 23=897(LC 1), 22=547(LC 1), 21=476(LC 1)
Max Grav All reactions 250 lb or less at joint(s) 18, 20, 19 except 33=925(LC 1), 24=4523(LC 1), 24=4523(LC 1)

FORCES. (lb) - Max. Comp./Max. Ten. - All forces 250 (lb) or less except when shown.
TOP CHORD 2-3=-2807/0, 3-4=-2807/0, 4-5=-3273/0, 5-6=-3213/0, 6-7=-3151/0, 7-9=0/616, 9-10=0/616, 10-11=0/5015, 11-12=0/5015, 12-13=0/699, 13-14=0/694
BOT CHORD 32-33=0/1744, 31-32=0/3272, 30-31=0/3272, 29-30=0/3272, 27-29=0/1413, 26-27=0/1413, 25-26=-2700/0, 24-25=-2700/0, 23-24=-2286/0, 22-23=-2286/0
WEBS 11-24=-321/0, 10-24=-2995/0, 10-26=0/2825, 7-26=-2598/0, 7-29=0/2330, 6-29=-1612/0, 5-29=-145/431, 12-24=-3530/0, 2-33=-1914/0, 2-32=0/1175, 12-23=0/877, 12-22=0/2099, 14-22=-940/0, 14-21=0/487, 4-32=-786/0

- NOTES-**
- Unbalanced floor live loads have been considered for this design.
 - All plates are 1.5x3 MT20 unless otherwise indicated.
 - Plates checked for a plus or minus 1 degree rotation about its center.
 - Provide mechanical connection (by others) of truss to bearing plate capable of withstanding 897 lb uplift at joint 23, 547 lb uplift at joint 22 and 476 lb uplift at joint 21.
 - Recommend 2x6 strongbacks, on edge, spaced at 10-0-0 oc and fastened to each truss with 3-10d (0.131" X 3") nails. Strongbacks to be attached to walls at their outer ends or restrained by other means.
 - CAUTION, Do not erect truss backwards.
 - Hanger(s) or other connection device(s) shall be provided sufficient to support concentrated load(s) 1330 lb down at 10-9-4 on top chord. The design/selection of such connection device(s) is the responsibility of others.
 - In the LOAD CASE(S) section, loads applied to the face of the truss are noted as front (F) or back (B).

LOAD CASE(S) Standard
1) Dead + Floor Live (balanced): Lumber Increase=1.00, Plate Increase=1.00
Uniform Loads (plf)
Vert: 18-33=-10, 1-17=-100
Concentrated Loads (lb)
Vert: 6=-1250(F)

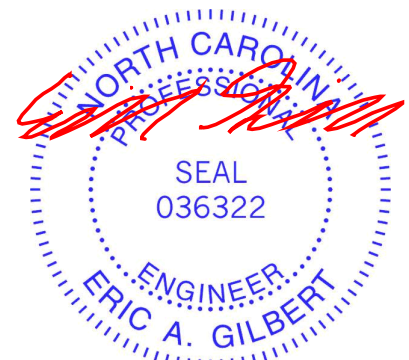

Job	Truss	Truss Type	Qty	Ply	Lot 5 Spartan Ridge	E15028370
J0221-0897	F4	Floor	2	1	Job Reference (optional)	

Comtech, Inc, Fayetteville, NC - 28314,

8.330 s Oct 7 2020 MiTek Industries, Inc. Wed Oct 28 09:07:30 2020 Page 1
ID:Y_aRO?CxglT9gUrhHW7gHdzqoOe-XcR3HKe1yvs2G5cQhq5vuhdtoJa6pUXRNlcwPKyOwtR

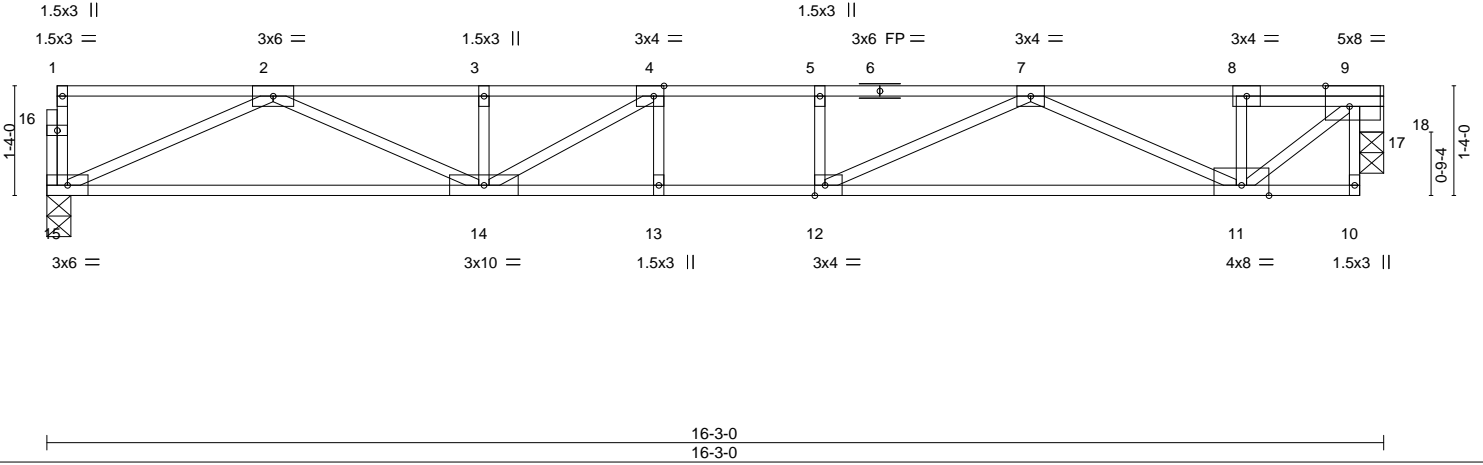
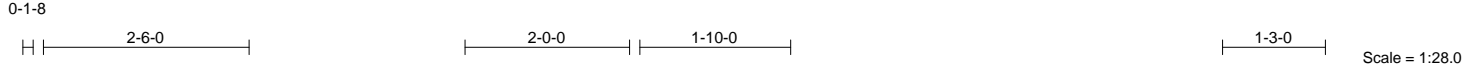

Plate Offsets (X,Y)-- [4:0-1-8,Edge], [9:0-3-8,Edge], [12:0-1-8,Edge]

LOADING (psf)	SPACING-	CSL.	DEFL.	in (loc)	l/defl	L/d	PLATES	GRIP
TCLL 40.0	Plate Grip DOL 1.00	TC 0.41	Vert(LL) -0.20	13-14	>970	480	MT20	244/190
TCDL 10.0	Lumber DOL 1.00	BC 0.77	Vert(CT) -0.25	11-12	>757	360		
BCLL 0.0	Rep Stress Incr YES	WB 0.61	Horz(CT) 0.03	18	n/a	n/a		
BCDL 5.0	Code IRC2015/TPI2014	Matrix-S					Weight: 84 lb	FT = 20%F, 11%E

LUMBER-
TOP CHORD 2x4 SP No.1(flat)
BOT CHORD 2x4 SP No.1(flat)
WEBS 2x4 SP No.3(flat)
OTHERS 4x4 SP No.2(flat)

BRACING-
TOP CHORD Structural wood sheathing directly applied or 6-0-0 oc purlins, except end verticals.
BOT CHORD Rigid ceiling directly applied or 10-0-0 oc bracing.

REACTIONS. (size) 15=0-3-8, 18=0-3-8
Max Grav 15=868(LC 1), 18=861(LC 1)

FORCES. (lb) - Max. Comp./Max. Ten. - All forces 250 (lb) or less except when shown.
TOP CHORD 2-3=-2577/0, 3-4=-2577/0, 4-5=-2848/0, 5-7=-2848/0, 7-8=-1040/0, 8-9=-1040/0
BOT CHORD 14-15=0/1620, 13-14=0/2848, 12-13=0/2848, 11-12=0/2214
WEBS 9-11=0/1289, 2-15=-1777/0, 2-14=0/1058, 3-14=-282/10, 7-11=-1298/0, 7-12=0/848, 4-14=-606/55, 9-18=-875/0

- NOTES-**
- 1) Unbalanced floor live loads have been considered for this design.
 - 2) Plates checked for a plus or minus 1 degree rotation about its center.
 - 3) Bearing at joint(s) 18 considers parallel to grain value using ANSI/TPI 1 angle to grain formula. Building designer should verify capacity of bearing surface.
 - 4) Recommend 2x6 strongbacks, on edge, spaced at 10-0-0 oc and fastened to each truss with 3-10d (0.131" X 3") nails. Strongbacks to be attached to walls at their outer ends or restrained by other means.
 - 5) CAUTION, Do not erect truss backwards.

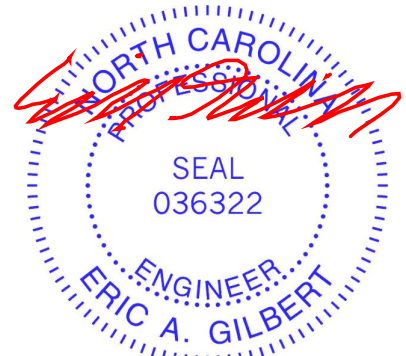

October 28, 2020

WARNING - Verify design parameters and READ NOTES ON THIS AND INCLUDED MITEK REFERENCE PAGE MII-7473 rev. 5/19/2020 BEFORE USE.
Design valid for use only with MiTek® connectors. This design is based only upon parameters shown, and is for an individual building component, not a truss system. Before use, the building designer must verify the applicability of design parameters and properly incorporate this design into the overall building design. Bracing indicated is to prevent buckling of individual truss web and/or chord members only. Additional temporary and permanent bracing is always required for stability and to prevent collapse with possible personal injury and property damage. For general guidance regarding the fabrication, storage, delivery, erection and bracing of trusses and truss systems, see **ANSI/TPI1 Quality Criteria, DSB-89 and BCSI Building Component Safety Information** available from Truss Plate Institute, 2670 Crain Highway, Suite 203 Waldorf, MD 20601



818 Soundside Road
Edenton, NC 27932

Job	Truss	Truss Type	Qty	Ply	Lot 5 Spartan Ridge	E15028371
J0221-0897	F5	Floor	1	1	Job Reference (optional)	

Comtech, Inc., Fayetteville, NC - 28314,

8.330 s Oct 7 2020 MiTek Industries, Inc. Wed Oct 28 09:07:31 2020 Page 1
ID:Y_aRO?Cxgl9gUrhHW7gHdzqOe-0o?RUgffiD_vuFAcFXc8RvQkliuUYyGacPLUymyOwtQ

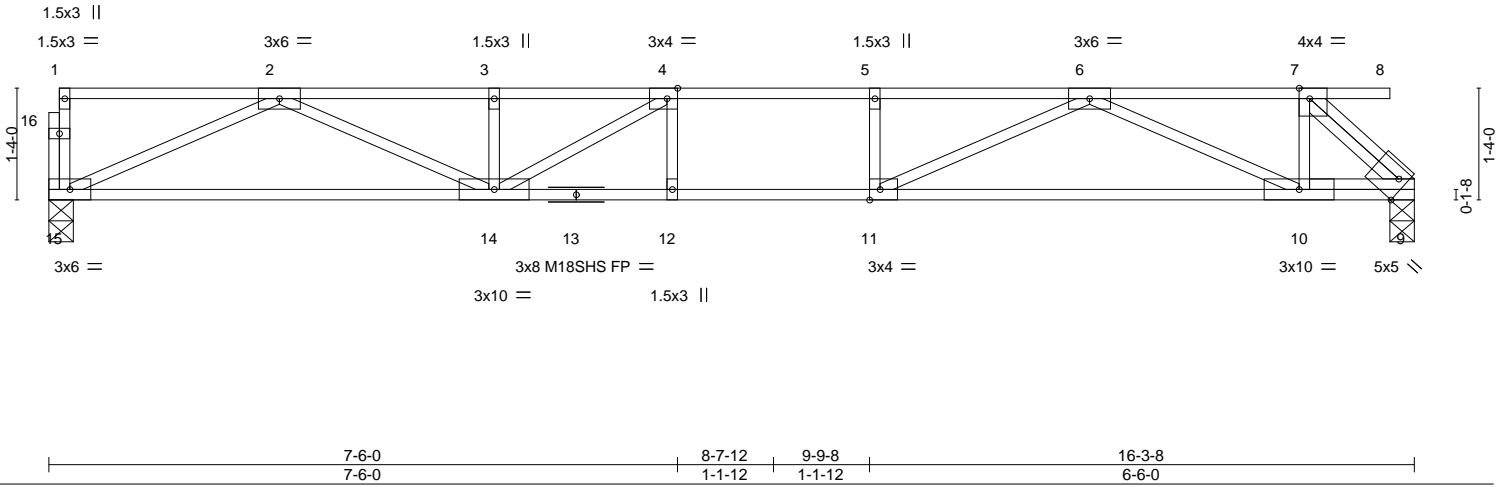
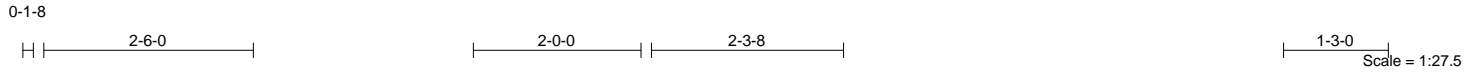

Plate Offsets (X,Y)-- [4:0-1-8,Edge], [7:0-1-8,Edge], [9:Edge,0-3-0], [11:0-1-8,Edge]

LOADING (psf)	SPACING-	CSI.	DEFL.	in (loc)	l/defl	L/d	PLATES	GRIP
TCLL 40.0	Plate Grip DOL 1.00	TC 0.65	Vert(LL) -0.25	12-14	>761	480	MT20	244/190
TCDL 10.0	Lumber DOL 1.00	BC 0.89	Vert(CT) -0.32	12-14	>609	360	M18SHS	244/190
BCLL 0.0	Rep Stress Incr YES	WB 0.52	Horz(CT) 0.05	9	n/a	n/a		
BCDL 5.0	Code IRC2015/TPI2014	Matrix-S						
							Weight: 83 lb	FT = 20%F, 11%E

LUMBER-
TOP CHORD 2x4 SP No.1(flat)
BOT CHORD 2x4 SP No.1(flat)
WEBS 2x4 SP No.3(flat)

BRACING-
TOP CHORD Structural wood sheathing directly applied or 6-0-0 oc purlins, except end verticals.
BOT CHORD Rigid ceiling directly applied or 10-0-0 oc bracing.

REACTIONS. (size) 15=0-3-8, 9=0-3-8
Max Grav 15=880(LC 1), 9=862(LC 1)

FORCES. (lb) - Max. Comp./Max. Ten. - All forces 250 (lb) or less except when shown.
TOP CHORD 2-3=-2631/0, 3-4=-2631/0, 4-5=-2908/0, 5-6=-2908/0, 6-7=-908/0
BOT CHORD 14-15=0/1646, 12-14=0/2908, 11-12=0/2908, 10-11=0/2165, 9-10=0/909
WEBS 7-10=0/589, 7-9=-1225/0, 2-15=-1807/0, 2-14=0/1088, 3-14=-289/18, 6-10=-1389/0, 6-11=0/960, 5-11=-285/0, 4-14=-642/44

- NOTES-**
- 1) Unbalanced floor live loads have been considered for this design.
 - 2) All plates are MT20 plates unless otherwise indicated.
 - 3) Plates checked for a plus or minus 1 degree rotation about its center.
 - 4) Recommend 2x6 strongbacks, on edge, spaced at 10-0-0 oc and fastened to each truss with 3-10d (0.131" X 3") nails.
Strongbacks to be attached to walls at their outer ends or restrained by other means.
 - 5) CAUTION, Do not erect truss backwards.



October 28, 2020

WARNING - Verify design parameters and READ NOTES ON THIS AND INCLUDED MITEK REFERENCE PAGE MII-7473 rev. 5/19/2020 BEFORE USE.
Design valid for use only with MiTek® connectors. This design is based only upon parameters shown, and is for an individual building component, not a truss system. Before use, the building designer must verify the applicability of design parameters and properly incorporate this design into the overall building design. Bracing indicated is to prevent buckling of individual truss web and/or chord members only. Additional temporary and permanent bracing is always required for stability and to prevent collapse with possible personal injury and property damage. For general guidance regarding the fabrication, storage, delivery, erection and bracing of trusses and truss systems, see **ANSI/TPI1 Quality Criteria, DSB-89 and BCSI Building Component Safety Information** available from Truss Plate Institute, 2670 Crain Highway, Suite 203 Waldorf, MD 20601



818 Soundside Road
Edenton, NC 27932

Job	Truss	Truss Type	Qty	Ply	Lot 5 Spartan Ridge	E15028372
J0221-0897	F6	Floor	3	1	Job Reference (optional)	

Comtech, Inc, Fayetteville, NC - 28314,

8.330 s Oct 7 2020 MiTek Industries, Inc. Wed Oct 28 09:07:31 2020 Page 1
ID:Y_aRO?Cxglt9gUrlHW7gHdzqoOe-0o?RUgffiD_vuFACfXc8RvQnMiwDYzoacPLUymyOwtQ

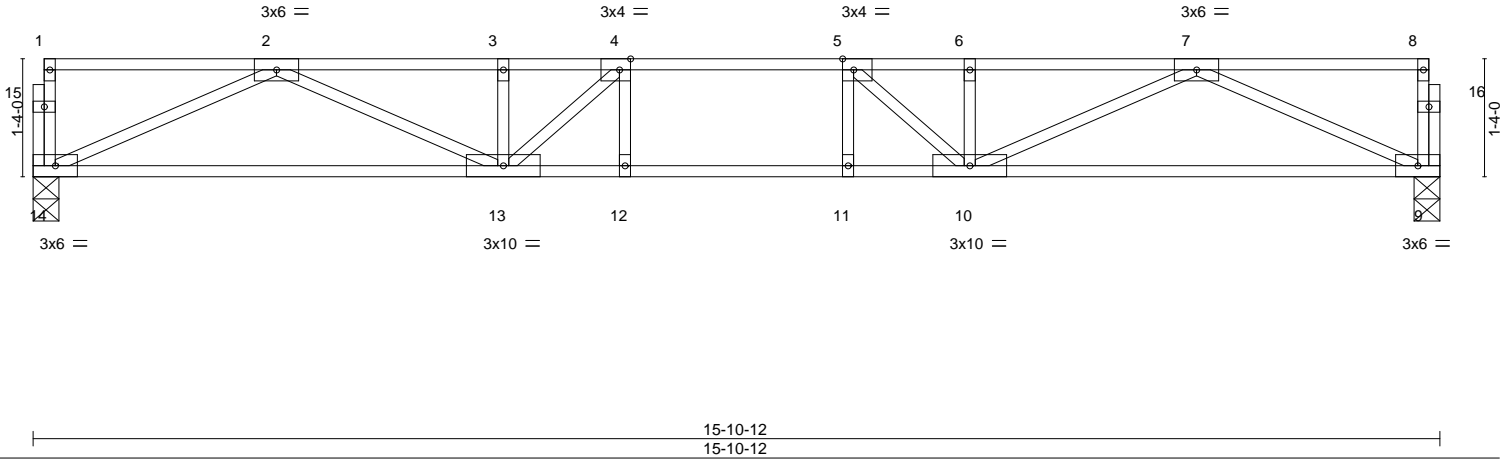
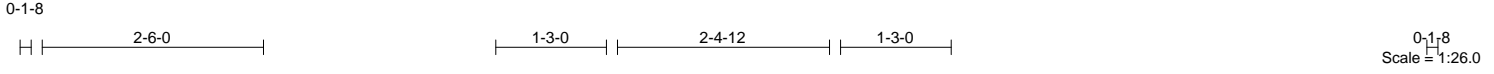

Plate Offsets (X,Y)-- [4:0-1-8,Edge], [5:0-1-8,Edge]

LOADING (psf)	SPACING-	CSI.	DEFL.	in (loc)	l/defl	L/d	PLATES	GRIP
TCLL 40.0	Plate Grip DOL 1.00	TC 0.48	Vert(LL) -0.17	12-13	>999	480	MT20	244/190
TCDL 10.0	Lumber DOL 1.00	BC 0.71	Vert(CT) -0.22	12-13	>849	360		
BCLL 0.0	Rep Stress Incr YES	WB 0.48	Horz(CT) 0.04	9	n/a	n/a		
BCDL 5.0	Code IRC2015/TPI2014	Matrix-S						
							Weight: 80 lb	FT = 20%F, 11%E

LUMBER-
TOP CHORD 2x4 SP No.1 (flat)
BOT CHORD 2x4 SP No.1 (flat)
WEBS 2x4 SP No.3 (flat)

BRACING-
TOP CHORD Structural wood sheathing directly applied or 6-0-0 oc purlins, except end verticals.
BOT CHORD Rigid ceiling directly applied or 10-0-0 oc bracing.

REACTIONS. (size) 14=0-3-8, 9=0-3-8
Max Grav 14=854(LC 1), 9=854(LC 1)

FORCES. (lb) - Max. Comp./Max. Ten. - All forces 250 (lb) or less except when shown.
TOP CHORD 2-3=-2503/0, 3-4=-2503/0, 4-5=-2738/0, 5-6=-2503/0, 6-7=-2503/0
BOT CHORD 13-14=0/1593, 12-13=0/2738, 11-12=0/2738, 10-11=0/2738, 9-10=0/1593
WEBS 2-14=-1748/0, 2-13=0/1006, 7-9=-1748/0, 7-10=0/1006, 5-10=-599/29, 4-13=-599/29

- NOTES-**
- 1) Unbalanced floor live loads have been considered for this design.
 - 2) All plates are 1.5x3 MT20 unless otherwise indicated.
 - 3) Plates checked for a plus or minus 1 degree rotation about its center.
 - 4) Recommend 2x6 strongbacks, on edge, spaced at 10-0-0 oc and fastened to each truss with 3-10d (0.131" X 3") nails. Strongbacks to be attached to walls at their outer ends or restrained by other means.

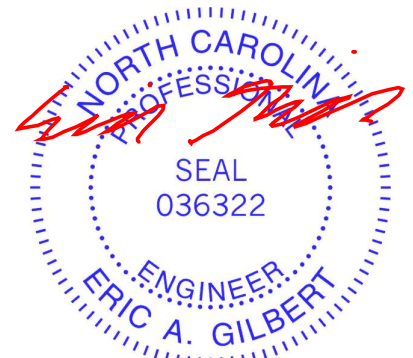

October 28, 2020

WARNING - Verify design parameters and READ NOTES ON THIS AND INCLUDED MITEK REFERENCE PAGE MII-7473 rev. 5/19/2020 BEFORE USE.
Design valid for use only with MiTek® connectors. This design is based only upon parameters shown, and is for an individual building component, not a truss system. Before use, the building designer must verify the applicability of design parameters and properly incorporate this design into the overall building design. Bracing indicated is to prevent buckling of individual truss web and/or chord members only. Additional temporary and permanent bracing is always required for stability and to prevent collapse with possible personal injury and property damage. For general guidance regarding the fabrication, storage, delivery, erection and bracing of trusses and truss systems, see **ANSI/TPI1 Quality Criteria, DSB-89 and BCSI Building Component Safety Information** available from Truss Plate Institute, 2670 Crain Highway, Suite 203 Waldorf, MD 20601



818 Soundside Road
Edenton, NC 27932

Job	Truss	Truss Type	Qty	Ply	Lot 5 Spartan Ridge	E15028373
J0221-0897	F7	Floor	8	1	Job Reference (optional)	

Comtech, Inc., Fayetteville, NC - 28314,

8.330 s Oct 7 2020 MiTek Industries, Inc. Wed Oct 28 09:07:33 2020 Page 1
ID:Y_aRO?CxglT9gUrlHW7gHdzqoOe-yB6BvLgvEqEc7ZK_MyfcWKV21Wcl0mf4jqb0fyOwTO

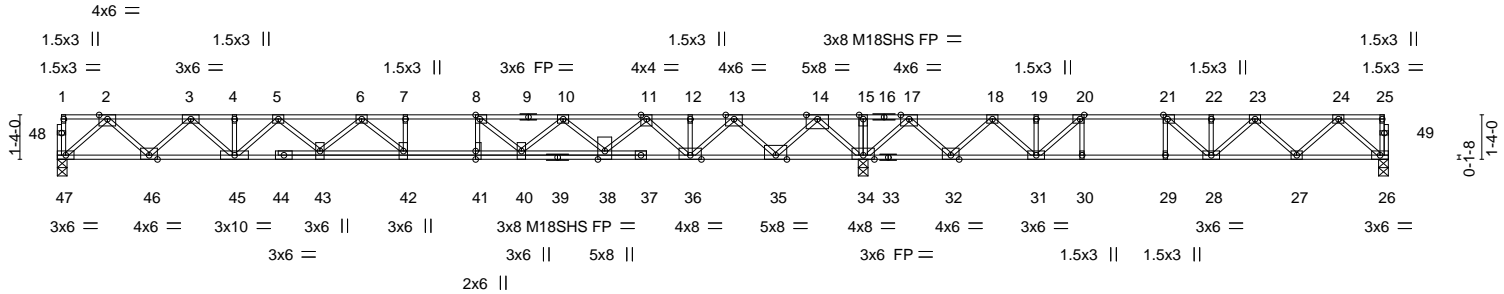
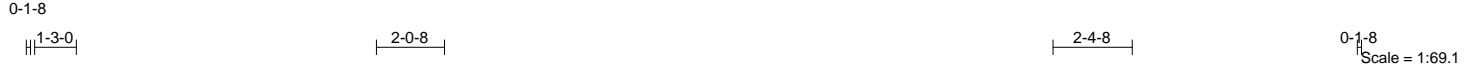

Plate Offsets (X,Y)--	[8:0-1-8,Edge], [20:0-1-8,Edge], [21:0-1-8,Edge], [41:0-3-0,0-0-0]
-----------------------	--------------------------------------------------------------------

LOADING (psf)	SPACING-	CSI.	DEFL.	in (loc)	l/defl	L/d	PLATES	GRIP
TCLL 40.0	Plate Grip DOL 1.00	TC 0.79	Vert(LL) -0.38	42	>752	480	MT20	244/190
TCDL 10.0	Lumber DOL 1.00	BC 0.74	Vert(CT) -0.52	42	>559	360	M18SHS	244/190
BCLL 0.0	Rep Stress Incr YES	WB 0.85	Horz(CT) 0.06	34	n/a	n/a		
BCDL 5.0	Code IRC2015/TPI2014	Matrix-S						
							Weight: 222 lb	FT = 20%F, 11%E

LUMBER-	BRACING-
TOP CHORD 2x4 SP 2400F 2.0E(flat)	TOP CHORD Structural wood sheathing directly applied or 6-0-0 oc purlins, except end verticals.
BOT CHORD 2x4 SP 2400F 2.0E(flat)	BOT CHORD Rigid ceiling directly applied or 6-0-0 oc bracing.
WEBS 2x4 SP No.3(flat)	

REACTIONS. (size) 47=0-3-8, 34=0-3-8, 26=0-3-8
Max Uplift 26=-9(LC 3)
Max Grav 47=1159(LC 3), 34=2662(LC 1), 26=725(LC 4)

FORCES. (lb) - Max. Comp./Max. Ten. - All forces 250 (lb) or less except when shown.

TOP CHORD
2-3=-2191/0, 3-4=-3744/0, 4-5=-3744/0, 5-6=-4866/0, 6-7=-5296/0, 7-8=-5296/0,
8-10=-4832/0, 10-11=-3721/0, 11-12=-1983/85, 12-13=-1983/85, 13-14=0/997,
14-15=0/3786, 15-17=0/3786, 17-18=-149/2166, 18-19=-1325/1462, 19-20=-1325/1462,
20-21=-1908/812, 21-22=-1936/310, 22-23=-1936/310, 23-24=-1242/108

BOT CHORD
46-47=0/1269, 45-46=0/3068, 43-45=0/4424, 42-43=0/5202, 41-42=0/5296, 40-41=0/5296,
38-40=0/4414, 36-38=0/2967, 35-36=-417/959, 34-35=-2150/0, 32-34=-2683/0,
31-32=-1777/852, 30-31=-812/1908, 29-30=-812/1908, 28-29=-812/1908,
27-28=-203/1689, 26-27=-30/774

WEBS
2-47=-1687/0, 2-46=0/1283, 3-46=-1219/0, 3-45=0/920, 5-45=-924/0, 5-43=0/599,
6-43=-474/0, 6-42=-345/475, 14-34=-2178/0, 14-35=0/1776, 13-35=-1735/0,
13-36=0/1444, 11-36=-1379/0, 11-38=0/1061, 10-38=-981/0, 10-40=0/691, 8-40=-1067/0,
8-41=-157/483, 17-34=-1626/0, 17-32=0/1262, 18-32=-1205/0, 18-31=0/835,
19-31=0/278, 20-31=-1430/0, 20-30=0/387, 24-26=-1028/40, 24-27=-109/652,
23-27=-621/131, 23-28=-145/336, 22-28=-324/0, 21-28=0/770, 21-29=-349/0

- NOTES-**
- 1) Unbalanced floor live loads have been considered for this design.
 - 2) All plates are MT20 plates unless otherwise indicated.
 - 3) All plates are 3x4 MT20 unless otherwise indicated.
 - 4) Plates checked for a plus or minus 1 degree rotation about its center.
 - 5) Provide mechanical connection (by others) of truss to bearing plate capable of withstanding 9 lb uplift at joint 26.
 - 6) Required 2x6 strongbacks, on edge, spaced at 10-0-0 oc and fastened to each truss with 3-10d (0.131" X 3") nails. Strongbacks to be attached to walls at their outer ends or restrained by other means.
 - 7) CAUTION, Do not erect truss backwards.



Job	Truss	Truss Type	Qty	Ply	Lot 5 Spartan Ridge	E15028374
J0221-0897	F7A	Floor	1	1	Job Reference (optional)	

Comtech, Inc., Fayetteville, NC - 28314,

8.330 s Oct 7 2020 MiTek Industries, Inc. Wed Oct 28 09:07:35 2020 Page 1
ID:Y_aRO?CxglT9gUrhHW7gHdzqoOe-uZEyK1i9mRUKNsUNUNh4blaQKQGYUknAX1Jh5XyOwtM

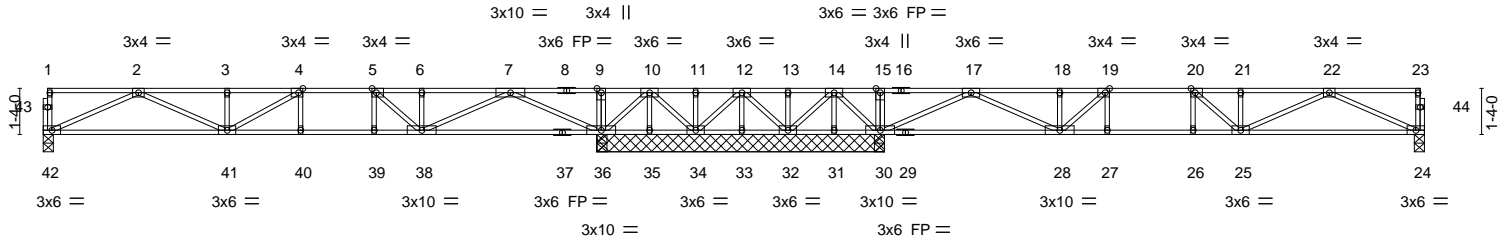
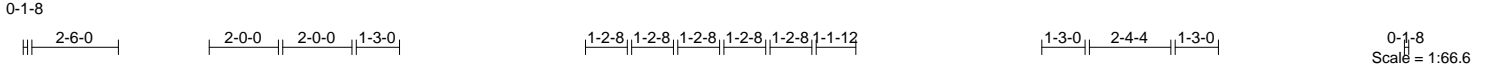

16-0-0	24-3-12	39-11-0
16-0-0	8-3-12	15-7-4
Plate Offsets (X,Y)--	[4:0-1-8,Edge], [5:0-1-8,Edge], [19:0-1-8,Edge], [20:0-1-8,Edge]	

LOADING (psf)	SPACING-	CSI.	DEFL.	in (loc)	l/defl	L/d	PLATES	GRIP
TCLL 40.0	Plate Grip DOL 1.00	TC 0.61	Vert(LL) -0.19	40-41	>996	480	MT20	244/190
TCDL 10.0	Lumber DOL 1.00	BC 0.85	Vert(CT) -0.26	40-41	>737	360		
BCLL 0.0	Rep Stress Incr YES	WB 0.61	Horz(CT) 0.05	24	n/a	n/a		
BCDL 5.0	Code IRC2015/TPI2014	Matrix-S					Weight: 209 lb	FT = 20%F, 11%E

LUMBER-	BRACING-
TOP CHORD 2x4 SP No.1(flat)	TOP CHORD Structural wood sheathing directly applied or 6-0-0 oc purlins, except end verticals.
BOT CHORD 2x4 SP No.1(flat)	BOT CHORD Rigid ceiling directly applied or 6-0-0 oc bracing.
WEBS 2x4 SP No.3(flat)	

REACTIONS. All bearings 8-3-12 except (jt=length) 42=0-3-8, 24=0-3-8.
 (lb) - Max Uplift All uplift 100 lb or less at joint(s) 34, 33 except 35=211(LC 9), 32=188(LC 4), 31=285(LC 4)
 Max Grav All reactions 250 lb or less at joint(s) 34, 33, 32, 31 except 42=762(LC 3), 36=1745(LC 3), 36=1734(LC 1), 30=1703(LC 7), 30=1694(LC 1), 24=743(LC 4)

FORCES. (lb) - Max. Comp./Max. Ten. - All forces 250 (lb) or less except when shown.
 TOP CHORD 2-3=-2141/0, 3-4=-2141/0, 4-5=-2108/0, 5-6=-1561/0, 6-7=-1561/0, 7-9=0/1388, 9-10=0/1382, 10-11=0/321, 11-12=0/321, 12-13=0/328, 13-14=0/328, 14-15=0/1405, 15-17=0/1411, 17-18=-1530/0, 18-19=-1530/0, 19-20=-2020/0, 20-21=-2042/0, 21-22=-2042/0
 BOT CHORD 41-42=0/1391, 40-41=0/2108, 39-40=0/2108, 38-39=0/2108, 36-38=0/398, 35-36=-674/0, 34-35=-674/0, 31-32=-697/0, 30-31=-697/0, 28-30=0/416, 27-28=0/2020, 26-27=0/2020, 25-26=0/2020, 24-25=0/1351
 WEBS 2-42=-1525/0, 2-41=0/830, 3-41=-294/0, 7-36=-1967/0, 7-38=0/1287, 5-38=-808/0, 10-36=-946/0, 10-34=0/504, 14-32=0/524, 14-31=-18/261, 14-30=-945/0, 17-30=-1915/0, 17-28=0/1234, 22-24=-1482/0, 22-25=0/763, 21-25=-261/0, 19-28=735/0

- NOTES-**
- 1) Unbalanced floor live loads have been considered for this design.
 - 2) All plates are 1.5x3 MT20 unless otherwise indicated.
 - 3) Plates checked for a plus or minus 1 degree rotation about its center.
 - 4) Provide mechanical connection (by others) of truss to bearing plate capable of withstanding 100 lb uplift at joint(s) 34, 33 except (jt=lb) 35=211, 32=188, 31=285.
 - 5) Recommend 2x6 strongbacks, on edge, spaced at 10-0-0 oc and fastened to each truss with 3-10d (0.131" X 3") nails. Strongbacks to be attached to walls at their outer ends or restrained by other means.
 - 6) CAUTION, Do not erect truss backwards.

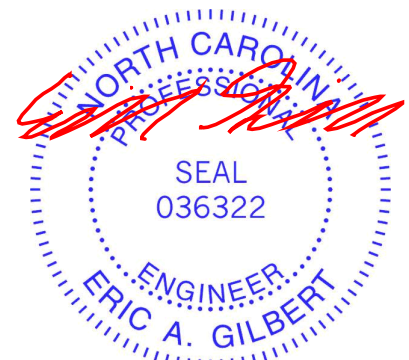

October 28, 2020

Job	Truss	Truss Type	Qty	Ply	Lot 5 Spartan Ridge	E15028375
J0221-0897	FG1	Floor Girder	1	1	Job Reference (optional)	

Comtech, Inc., Fayetteville, NC - 28314,

8.330 s Oct 7 2020 MiTek Industries, Inc. Wed Oct 28 09:07:36 2020 Page 1
ID:Y_aRO?CxglT9gUrIHW7gHdzqOe-MmoKXNjnXlCB_03Z24CJ7y7gNjhiDCHJmh3FdzyOwL

0-1-8



Scale = 1:16.3

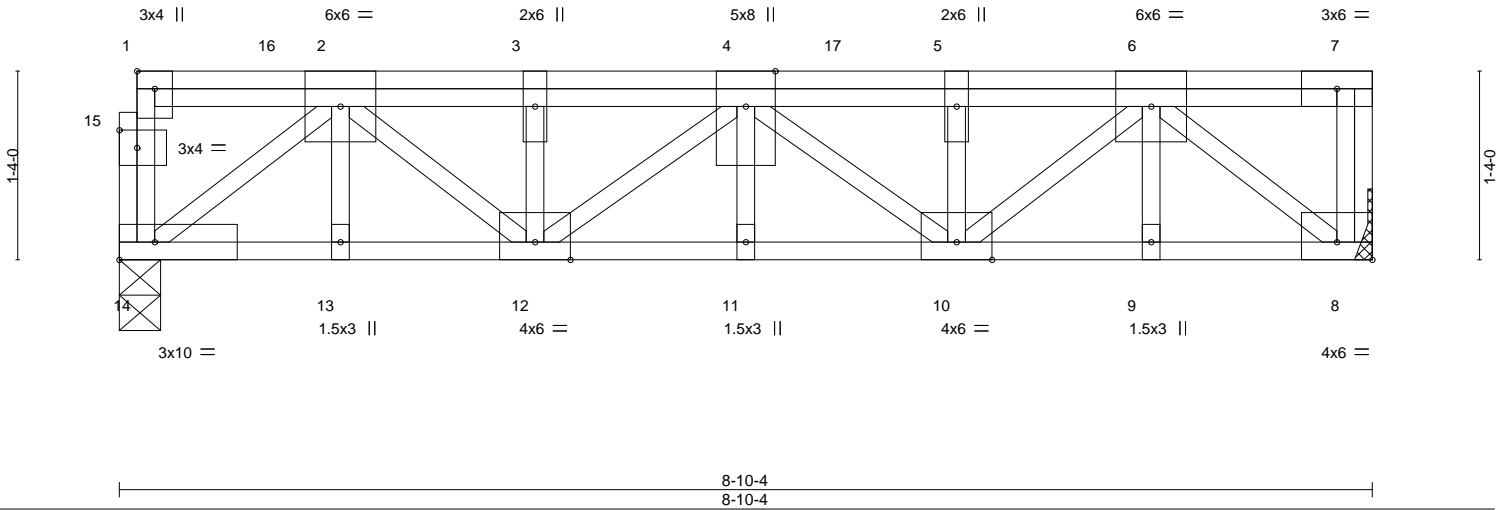

Plate Offsets (X,Y)-- [1:Edge,0-1-8], [8:Edge,0-1-8], [15:0-1-8,0-1-8]

LOADING (psf)	SPACING-	2-0-0	CSI.	DEFL.	in (loc)	l/defl	L/d	PLATES	GRIP
TCLL 40.0	Plate Grip DOL	1.00	TC 0.27	Vert(LL)	-0.04	11	>999	MT20	244/190
TCDL 10.0	Lumber DOL	1.00	BC 0.57	Vert(CT)	-0.06	11	>999		
BCLL 0.0	Rep Stress Incr	NO	WB 0.53	Horz(CT)	0.02	8	n/a		
BCDL 5.0	Code	IRC2015/TPI2014	Matrix-P					Weight: 66 lb	FT = 20%F, 11%E

LUMBER-
TOP CHORD 2x4 SP No.1(flat)
BOT CHORD 2x4 SP No.1(flat)
WEBS 2x4 SP No.3(flat)

BRACING-
TOP CHORD Structural wood sheathing directly applied or 6-0-0 oc purlins, except end verticals.
BOT CHORD Rigid ceiling directly applied or 10-0-0 oc bracing.

REACTIONS. (size) 14=0-3-8, 8=Mechanical
Max Grav 14=1475(LC 1), 8=1350(LC 1)

FORCES. (lb) - Max. Comp./Max. Ten. - All forces 250 (lb) or less except when shown.
TOP CHORD 2-3=-2485/0, 3-4=-2485/0, 4-5=-2414/0, 5-6=-2414/0
BOT CHORD 13-14=0/1625, 12-13=0/1625, 11-12=0/2734, 10-11=0/2734, 9-10=0/1566, 8-9=0/1566
WEBS 2-14=-2067/0, 2-12=0/1119, 3-12=-500/0, 6-8=-2003/0, 6-10=0/1104, 5-10=-436/0, 4-10=-404/0, 4-12=-315/0

- NOTES-**
- Plates checked for a plus or minus 1 degree rotation about its center.
 - Refer to girder(s) for truss to truss connections.
 - Recommend 2x6 strongbacks, on edge, spaced at 10-0-0 oc and fastened to each truss with 3-10d (0.131" X 3") nails. Strongbacks to be attached to walls at their outer ends or restrained by other means.
 - CAUTION, Do not erect truss backwards.
 - Hanger(s) or other connection device(s) shall be provided sufficient to support concentrated load(s) 473 lb down at 1-1-12, 471 lb down at 3-1-12, and 471 lb down at 5-1-12, and 471 lb down at 7-1-12 on top chord. The design/selection of such connection device(s) is the responsibility of others.
 - In the LOAD CASE(S) section, loads applied to the face of the truss are noted as front (F) or back (B).

LOAD CASE(S) Standard
1) Dead + Floor Live (balanced): Lumber Increase=1.00, Plate Increase=1.00
Uniform Loads (plf)
Vert: 8-14=-10, 1-7=-100
Concentrated Loads (lb)
Vert: 3=-471(B) 6=-471(B) 16=-473(B) 17=-471(B)



October 28, 2020

WARNING - Verify design parameters and READ NOTES ON THIS AND INCLUDED MITEK REFERENCE PAGE MII-7473 rev. 5/19/2020 BEFORE USE.
Design valid for use only with MiTek® connectors. This design is based only upon parameters shown, and is for an individual building component, not a truss system. Before use, the building designer must verify the applicability of design parameters and properly incorporate this design into the overall building design. Bracing indicated is to prevent buckling of individual truss web and/or chord members only. Additional temporary and permanent bracing is always required for stability and to prevent collapse with possible personal injury and property damage. For general guidance regarding the fabrication, storage, delivery, erection and bracing of trusses and truss systems, see **ANSI/TPI1 Quality Criteria, DSB-89 and BCSI Building Component Safety Information** available from Truss Plate Institute, 2670 Crain Highway, Suite 203 Waldorf, MD 20601



818 Soundside Road
Edenton, NC 27932

Symbols

PLATE LOCATION AND ORIENTATION

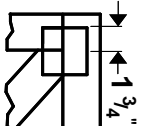

Center plate on joint unless x, y offsets are indicated. Dimensions are in ft-in-sixteenths. Apply plates to both sides of truss and fully embed teeth.

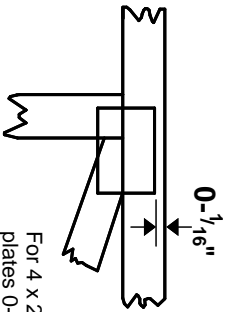

For 4 x 2 orientation, locate plates 0- 1/16" from outside edge of truss.



This symbol indicates the required direction of slots in connector plates.

* Plate location details available in **MITek 20/20 software** or upon request.

PLATE SIZE

4 X 4

The first dimension is the plate width measured perpendicular to slots. Second dimension is the length parallel to slots.

LATERAL BRACING LOCATION

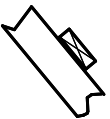

Indicated by symbol shown and/or by text in the bracing section of the output. Use T or I bracing if indicated.

BEARING



Indicates location where bearings (supports) occur. Icons vary but reaction section indicates joint number where bearings occur. Min size shown is for crushing only.

Industry Standards:

ANSI/TFP 1: National Design Specification for Metal Plate Connected Wood Truss Construction.
DSB-89: Design Standard for Bracing, Building Component Safety Information, Guide to Good Practice for Handling, Installing & Bracing of Metal Plate Connected Wood Trusses.

Numbering System

6-4-8
dimensions shown in ft-in-sixteenths
(Drawings not to scale)



JOINTS ARE GENERALLY NUMBERED/LETTERED CLOCKWISE AROUND THE TRUSS STARTING AT THE JOINT FARTHEST TO THE LEFT.

CHORDS AND WEBS ARE IDENTIFIED BY END JOINT NUMBERS/LETTERS.

PRODUCT CODE APPROVALS

ICC-ES Reports:

ESR-1311, ESR-1352, ESR1988
ER-3907, ESR-2362, ESR-1397, ESR-3282

Trusses are designed for wind loads in the plane of the truss unless otherwise shown.

Lumber design values are in accordance with ANSI/TFP 1 section 6.3 These truss designs rely on lumber values established by others.

© 2012 MITteK® All Rights Reserved



MITek Engineering Reference Sheet: MII-7473 rev. 5/19/2020



General Safety Notes

Failure to Follow Could Cause Property Damage or Personal Injury

1. Additional stability bracing for truss system, e.g. diagonal or X-bracing, is always required. See BCSI.
2. Truss bracing must be designed by an engineer. For wide truss spacing, individual lateral braces themselves may require bracing, or alternative Tor I bracing should be considered.
3. Never exceed the design loading shown and never stack materials on inadequately braced trusses.
4. Provide copies of this truss design to the building designer, erection supervisor, property owner and all other interested parties.
5. Cut members to bear tightly against each other.
6. Place plates on each face of truss at each joint and embed fully. Knots and wane at joint locations are regulated by ANSI/TFP 1.
7. Design assumes trusses will be suitably protected from the environment in accord with ANSI/TFP 1.
8. Unless otherwise noted, moisture content of lumber shall not exceed 19% at time of fabrication.
9. Unless expressly noted, this design is not applicable for use with fire retardant, preservative treated, or green lumber.
10. Camber is a non-structural consideration and is the responsibility of truss fabricator. General practice is to camber for dead load deflection.
11. Plate type, size, orientation and location dimensions indicated are minimum plating requirements.
12. Lumber used shall be of the species and size, and in all respects, equal to or better than that specified.
13. Top chords must be sheathed or purlins provided at spacing indicated on design.
14. Bottom chords require lateral bracing at 10 ft. spacing, or less, if no ceiling is installed, unless otherwise noted.
15. Connections not shown are the responsibility of others.
16. Do not cut or alter truss member or plate without prior approval of an engineer.
17. Install and load vertically unless indicated otherwise.
18. Use of green or treated lumber may pose unacceptable environmental, health or performance risks. Consult with project engineer before use.
19. Review all portions of this design (front, back, words and pictures) before use. Rewriting pictures alone is not sufficient.
20. Design assumes manufacture in accordance with ANSI/TFP 1 Quality Criteria.
21. The design does not take into account any dynamic or other loads other than those expressly stated.