

GENERAL NOTES:

GENERAL: ALL NOTES ARE FOR SUPPLEMENTING THE PLANS AND SPECIFICATIONS AND ARE IN NO WAY TO BE CONSIDERED AS EXCLUDING ANY ITEM IN THEM.

CONTRACTOR TO OBTAIN ALL MISC. UTILITIES AND UTILITY CLEARANCES AND EXCAVATION PERMITS.

CODE: DESIGN AND CONSTRUCTION TO BE IN ACCORD WITH THE 2018 NC RESIDENTIAL CODE (NCRS) AND THE PARTICULAR CODES AS REFERENCED IN NCRS.

DESIGN CRITERIA:
 FLOOR LIVE: 40 PSF
 ROOF LIVE: 20 PSF
 ATTIC LOAD: 20 PSF
 WIND SPEED: 110 MPH
 WALL COMPONENT: 24 PSF
 NET UPLIFT: 20 PSF

FOUNDATION: EXCAVATION FOR AND BEARING MATERIAL FOR FOUNDATIONS SHOULD BE SUPERVISED AND APPROVED BY PWD PRIOR TO FOOTING INSTALLATION.

MATERIAL SATISFACTORY FOR CONTROLLED FILL AND BACKFILL MATERIAL AROUND AND ABOVE FOOTINGS SHALL INCLUDE CLEAN SOIL OR BANKRUN SAND AND GRAVEL (GW, GC, SG, SM, ML & CL), BUT EXCLUDE HIGHLY PLASTIC CLAYS (MH & CH) OR HIGH SHRINK SWELL SOILS. THE FILL MATERIALS SHALL BE FREE FROM TOPSOIL, ORGANIC CONTAMINATED SOIL AND ROCK FRAGMENTS HAVING A MAJOR DIMENSION GREATER THAN FOUR (4) INCHES, AND SHALL CONTAIN NO ICE OR SNOW.

FOOTINGS ARE DESIGNED FOR AN ASSUMED SOIL BEARING PRESSURE OF 2000 PSF.

CARE SHOULD BE TAKEN TO ASSURE THAT DURING PLACING OF CONCRETE FOOTINGS ON GRADE NO ORGANIC MATTER, SALTS, OR CLAYS ARE MIXED WITH THE CONCRETE.

CONCRETE: REINFORCED CONCRETE TO HAVE THE FOLLOWING COMPRESSIVE STRENGTH (F_c)

SLAB ON GRADE: 3000 PSI
 FOOTINGS: 3000 PSI

EXPOSED CONCRETE SHALL BE AIR-ENTRAINED.

GROUT FOR BASE PLATES SHALL BE NON-SHRINKABLE GROUT AND SHALL HAVE A MINIMUM SPECIFIED COMPRESSIVE STRENGTH AT 28 DAYS OF 5,000 P.S.I.

REINFORCING STEEL: ASTM A615 GRADE 60.

WELDED WIRE FABRIC SHALL CONFORM TO ASTM A-185.

REINFORCING STEEL MARKED CONTINUOUS (CONT.) SHALL BE LAPPED 48 X BAR DIAMETER AT SPLICES. ALL REINFORCING STEEL SHALL BE HELD SECURELY IN PLACE TO PREVENT DISLOCATION DURING THE POURING OPERATION.

SLAB REINFORCING BARS SHALL BE SUPPORTED ON HIGH CHAIRS AND BAR SPACERS OF SUITABLE DESIGN. "HOOKING" OF WELDED WIRE FABRIC SHALL NOT BE PERMITTED.

DETAILING OF ALL CONCRETE STEEL REINFORCEMENT SHALL BE IN ACCORDANCE WITH THE MANUAL OF STANDARD PRACTICE FOR DETAILING REINFORCED CONCRETE STRUCTURES (A.C.I. 315-89).

NO CONCRETE SHALL BE PLACED UNTIL ALL EMBEDDED WORK HAS BEEN INSTALLED, TESTED AND INSPECTED.

EXCEPT AS OTHERWISE SHOWN, MINIMUM PROTECTION (CONCRETE COVER) FOR REINFORCING STEEL SHALL BE AS FOLLOWS:

CONCRETE SURFACES EXPOSED TO SOIL:
 1 1/2" FOR SLABS
 3" FOR FOOTINGS

INTERIOR CONCRETE SURFACES:
 3/4" FOR SLABS

CONCRETE SURFACES EXPOSED TO WEATHER:
 1 1/2" FOR SLABS

WOOD: ALL WOOD TO BE SOUTHERN YELLOW PINE (SYP) NO. 2 OR HIGHER. ALL FASTENERS AND HANGERS TO BE HOT DIPPED GALVANIZED (AT A MINIMUM), PRESERVATIVE PRESSURE TREATMENT TO BE IN ACCORDANCE WITH AWPA STANDARD M4-D6 & U1-D7. MINIMUM PRESERVATION TREATMENTS:
 POSTS: UC4A
 ALL OTHER WOOD MEMBERS: UC3B

ROOF SHEATHING C-D GRADE "APA" EXTERIOR STRUCTURAL PANELS OR APPROVED EQUAL. PLACE WITH LONG DIMENSION PERPENDICULAR TO FRAMING. STAGGER END JOINTS. FASTEN WITH 8d HOT-DIPPED GALVANIZED BOX NAILS AT 6" O.C. AT ALL SUPPORTED EDGES, EXCEPT WITHIN THE FIRST 4' FROM ROOF EDGE. FASTENERS WITHIN THE FIRST 4' SHALL BE AT 4" O.C.

ALL MULTI-PLY LAMINATED VENEER LUMBER (LVL) HEADERS LINTELS & STUD COLUMNS SHALL BE CONNECTED SUCH THAT THEY ACT AS A SINGLE MEMBER.

LVL SPECS: F_b=2900 PSI F_v=285 PSI E=1,900,000 PSI

TIMBER TRUSS

- TRUSS FABRICATOR TO VERIFY FIELD DIMENSIONS WITH GENERAL CONTRACTOR.
- ALL TIMBER TRUSSES SHALL BE DESIGNED FOR:
 110 MPH WIND SPEED
 TOP CHORD LL = 30 PSF
 TOP CHORD DL = 10 PSF
 BOT CHORD LL = 20 PSF (GENERAL ATTIC)
 BOT CHORD DL = 15 PSF
 NET UPLIFT = 25 PSF
 IN ACCORDANCE WITH GOVERNING LOAD COMBINATIONS PER IBC 1605.
- TRUSS SUPPLIER SHALL SUBMIT SHOP DRAWINGS WITH NORTH CAROLINA REGISTERED ENGINEER SEAL BEFORE FABRICATION.
- ALL MEMBERS TO BE SYP NO. 2 OR HIGHER

MASONRY: LOAD BEARING CONCRETE MASONRY CONSTRUCTION TO BE IN ACCORDANCE WITH ASCE 5/ACI 530/TMS 402-08, "BUILDING CODE REQUIREMENTS FOR MASONRY STRUCTURES", AND ASCE 6/ACI 530.1/TMS/602-08, SPECIFICATIONS FOR MASONRY STRUCTURES." BEARING WALLS AND PIERS TO CONSIST ENTIRELY OF LOAD BEARING UNITS.

ALL MASONRY CONSTRUCTION TO BE IN ACCORDANCE WITH ACCEPTABLE INDUSTRY STANDARDS AND METHODS OF CONSTRUCTION.

PROVIDE DUR D WAL OR EQUAL EVERY BLOCK COURSE BELOW FINISHED FLOOR AND EVERY OTHER COURSE ABOVE FINISHED FLOOR UNLESS OTHERWISE SHOWN ON THE ARCHITECTURAL SECTION. ALL HORIZONTAL WALL REINFORCING TO BE TRUSSED AND GALVANIZED. AT CORNERS AND INTERSECTIONS HORIZONTAL WALL REINFORCING TO BE FULLY LAPPED WITH TRUSSED GALVANIZED CORNERS AND TEES.

HOLLOW LOAD BEARING MASONRY UNITS SHALL CONFORM TO ASTM C90 REGULAR WEIGHT (UNLESS NOTED OTHERWISE). SOLID LOAD BEARING CONCRETE MASONRY UNITS SHALL CONFORM TO ASTM C145. THE UNIT MASONRY SHALL HAVE A NET UNIT COMPRESSIVE STRENGTH OF 2,000 PSI. THE COMPRESSIVE STRENGTH OF THE UNITS SHALL BE DETERMINED IN ACCORDANCE WITH ASTM C140 '70, STANDARD METHODS OF SAMPLING AND TESTING CONCRETE MASONRY UNITS. A 28 DAY PRISM STRENGTH VALUE OF 1500 PSI HAS BEEN USED IN THE DESIGN.

MORTAR FOR CONCRETE MASONRY SHALL CONFORM TO THE REQUIREMENTS OF THE ASTM SPECIFICATION FOR MORTAR UNIT MASONRY ASTM C270, TYPE M OR S. GROUT SHALL CONFORM TO ASTM C476. CONCRETE GROUT USED TO FILL CORES IN MASONRY UNITS SHALL HAVE A 28 DAY STRENGTH OF 3,000 PSI MIN.

ALL MASONRY TO BE LAID IN TYPE M OR S MORTAR WITH FULL HEAD AND BED JOINT.

No floor plan submitted. All bedroom windows must meet egress. Must have one side hinged min 3/0 6/8 exterior door. All habitable space doors must be min 2/6 x 6/8. All floor spaces must meet minimum code.

NOTICE TO CONTRACTOR
 All construction must comply with current NC Building Codes and is subject to field inspection and verification.

APPROVED
 Limited building only review
 Permit holder responsible for
 full compliance with the code

04/14/2021

Signature

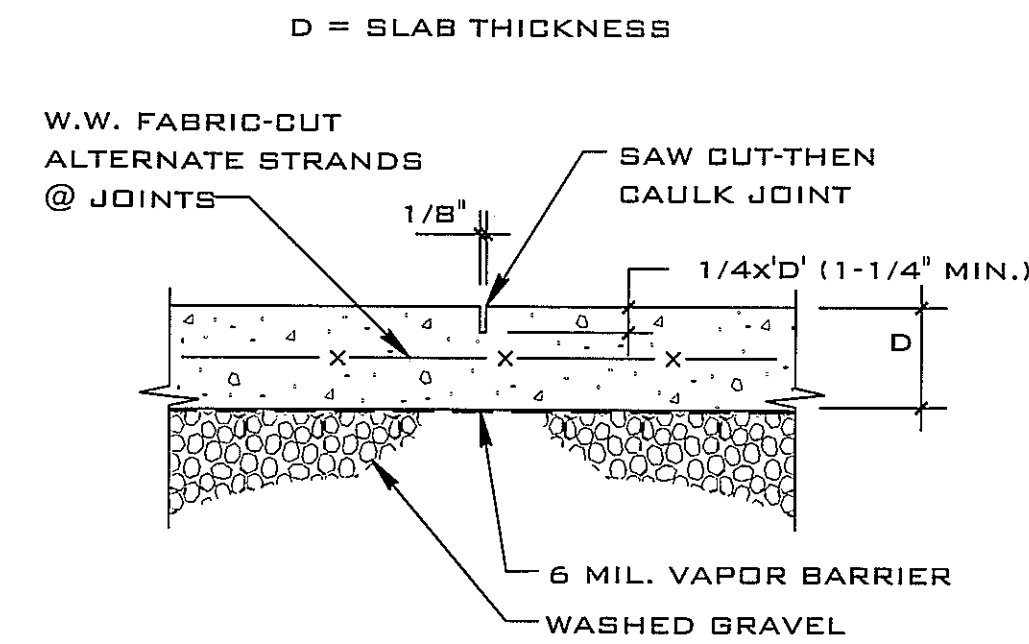

PROVIDE CONTROL JOINTS BETWEEN CONSTRUCTION JOINTS WITH SPACING NOT TO EXCEED IN FEET 3 TIMES THE SLAB THICKNESS IN INCHES IN EACH DIRECTION. CONTROL JOINTS TO BE FORMED WHILE CONCRETE IS STILL PLASTIC OR SAW CUT WITHIN 8 HOURS OF PLACING CONCRETE.

D1A SAWED CONTROL JOINT (S.J.)
 DET

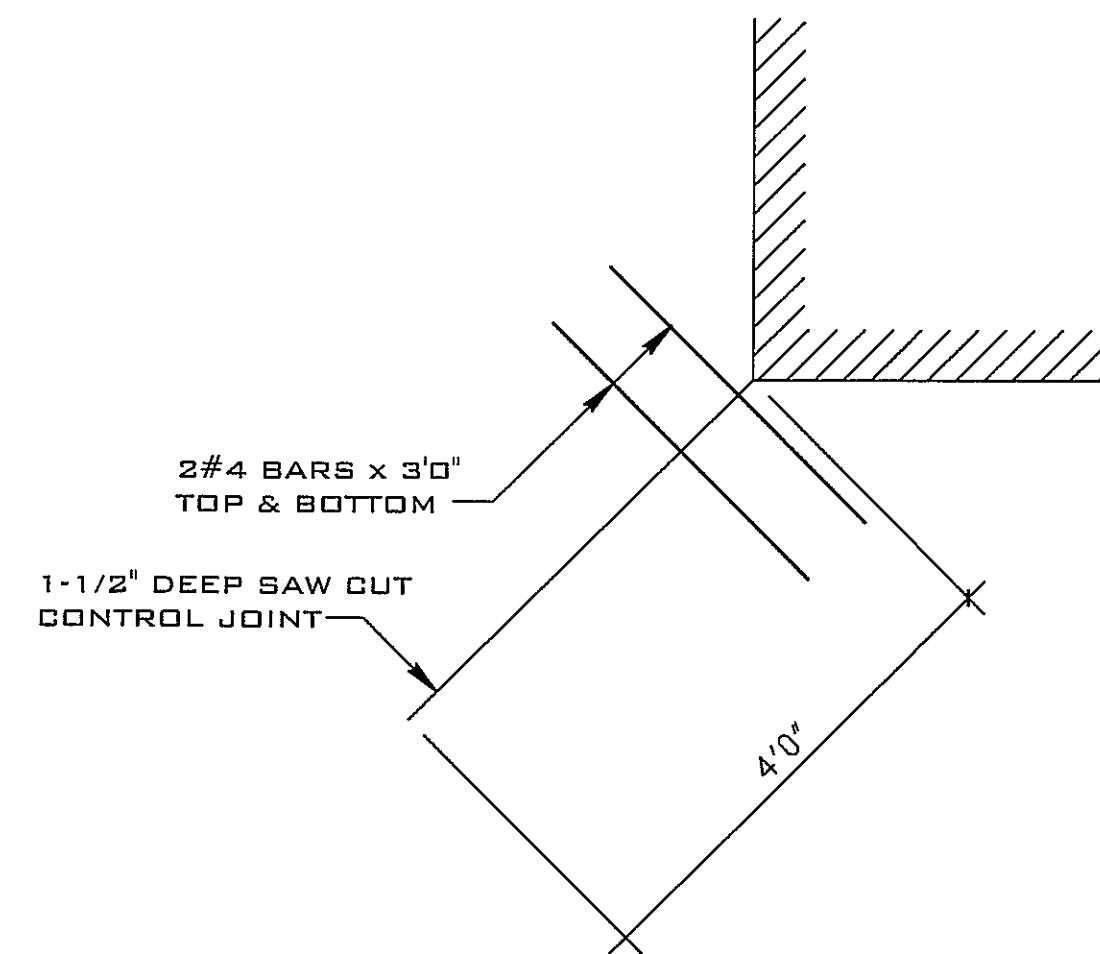

D1B TYPICAL DIAGONAL SAW CUT
 DET SLAB CONTROL JOINT DETAIL

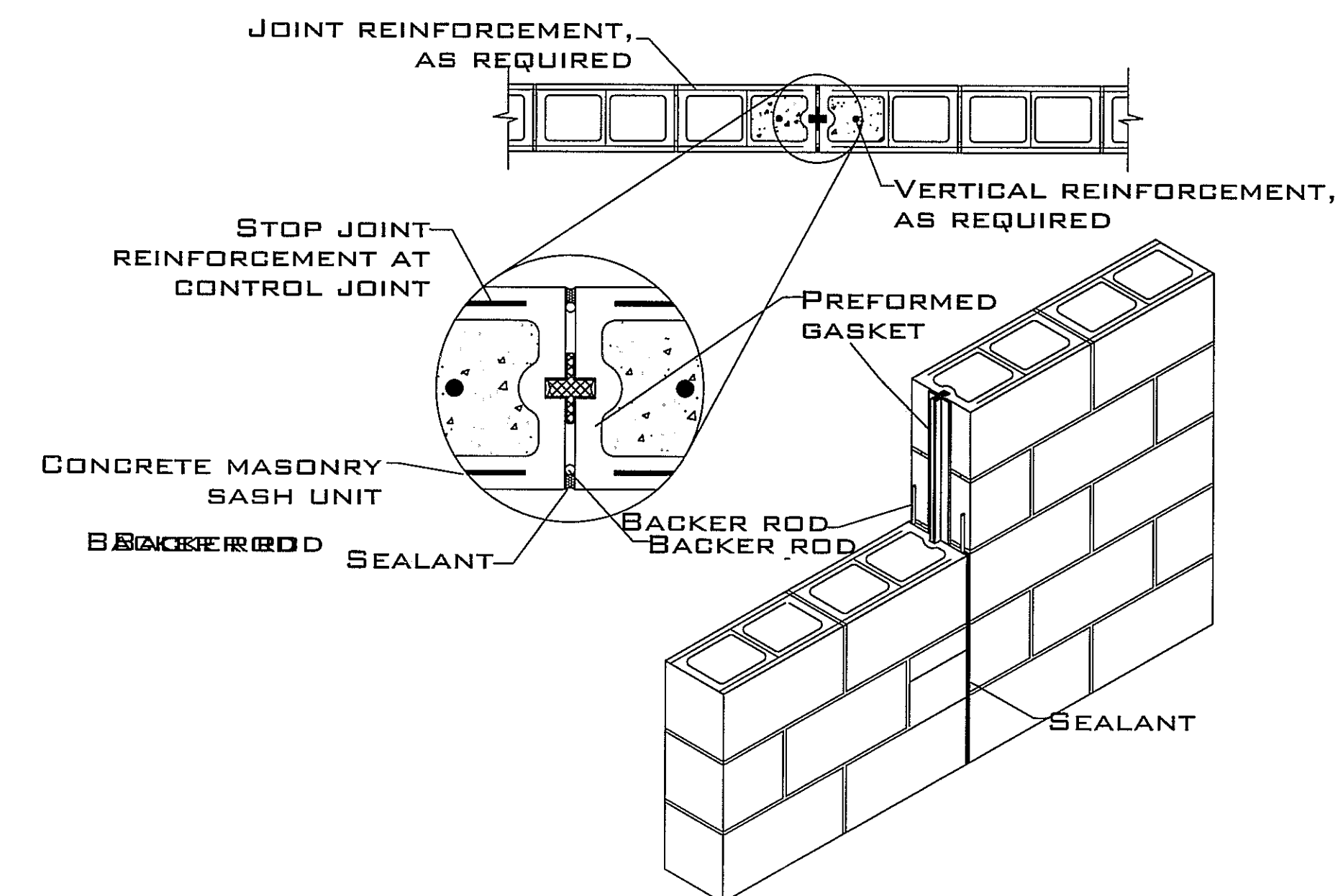

D40 MASONRY CONTROL JOINT
 DET PROVIDE AT 16' INTERVAL MAX

MARK	DATE	REVISION

PERMIT HOLDER REVIEWED BY: JERRARD RUFARD REDMOND, PE
 DESIGN REVIEWED BY: JERRARD RUFARD REDMOND, PE
 CHECKED BY: JERRARD RUFARD REDMOND, PE
 DRAWN BY: JERRARD RUFARD REDMOND, PE
 PROJECT NO: 2019173
 SHEET NO: S1

JEROME RUFARD REDMOND, PE
 BUILDING ENGINEERING & DESIGN
 8209A MARKET STREET STE. 222
 WILMINGTON, NC 28411
 910.915.6529
 JREDNCS@YAHOO.COM

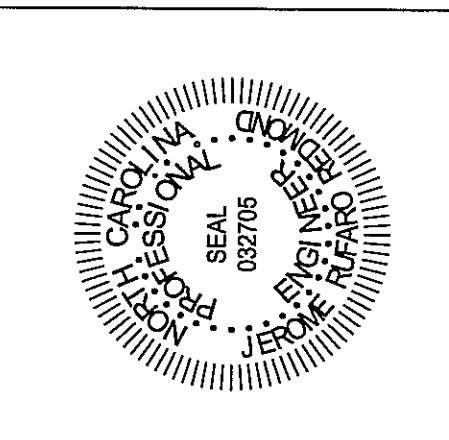

BB 1675-2 PLAN
 HARNETT COUNTY, NC

DRAWING TITLE
 GENERAL NOTES

DRAWN BY:	JRR
CHECKED BY:	JRR
SCALE:	AS SHOWN
DATE:	06.02.19
PROJECT	SHEET
02019173	S1

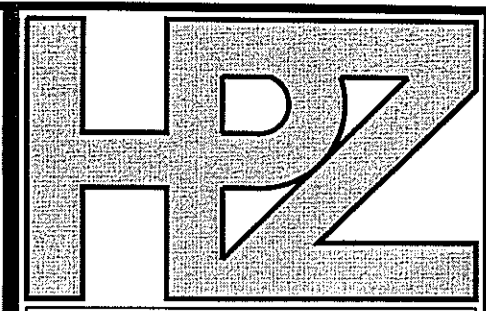

House Plan Zone, LLC

House Plan Zone, LLC. Email: HPZplans@comcast.net Fax: 1-800-574-1387



Plan ID:

BB-1675-2

Date: 06.06.13

Drawn By: C.T.B.

SHEET NUMBER

2

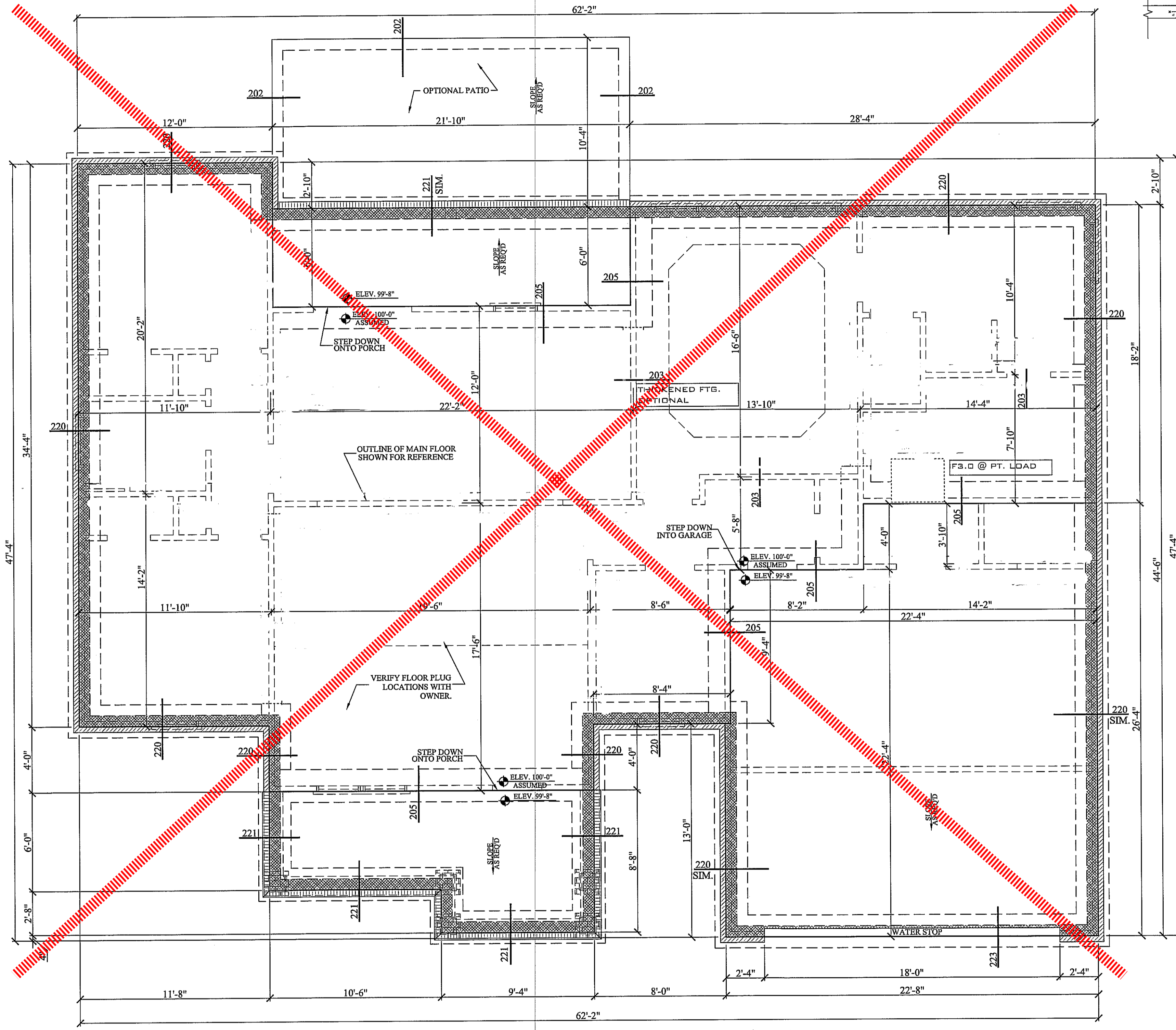

201 FOUNDATION PLAN SCALE 1/4" = 1'-0"

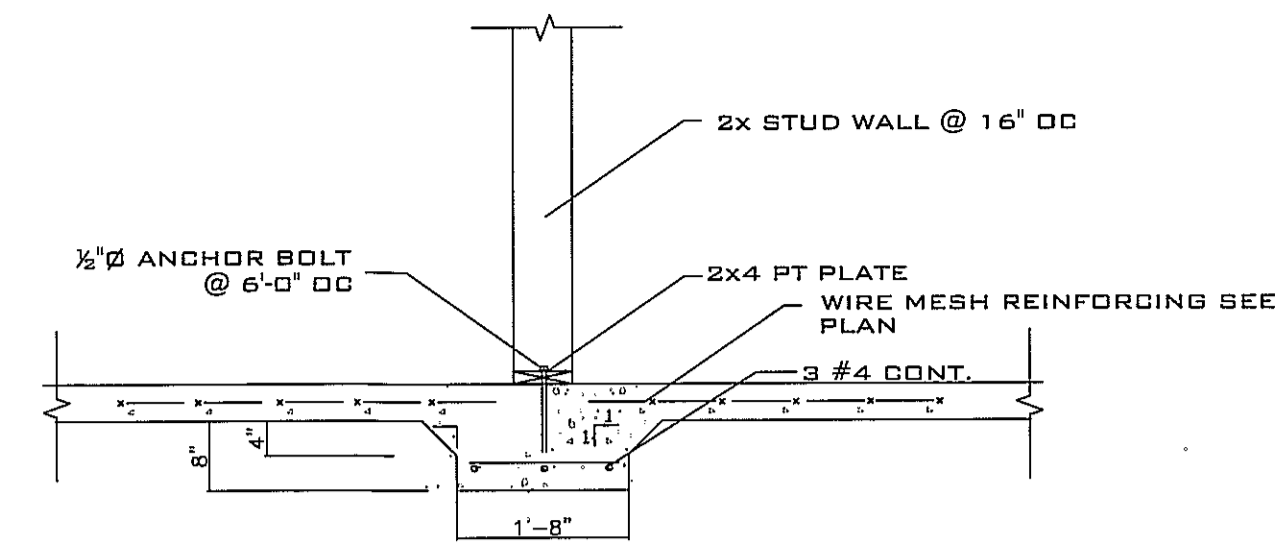

203 THICKENED SLAB SCALE: NTS

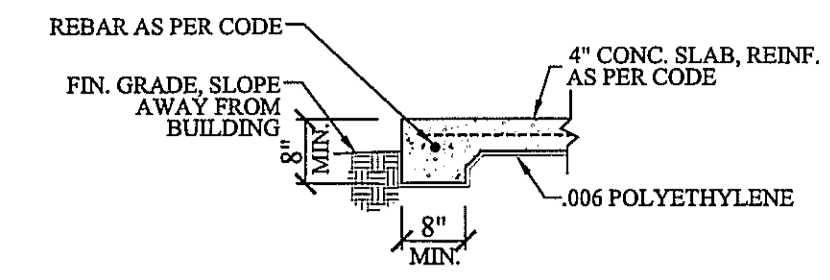

202 FTG. DET.

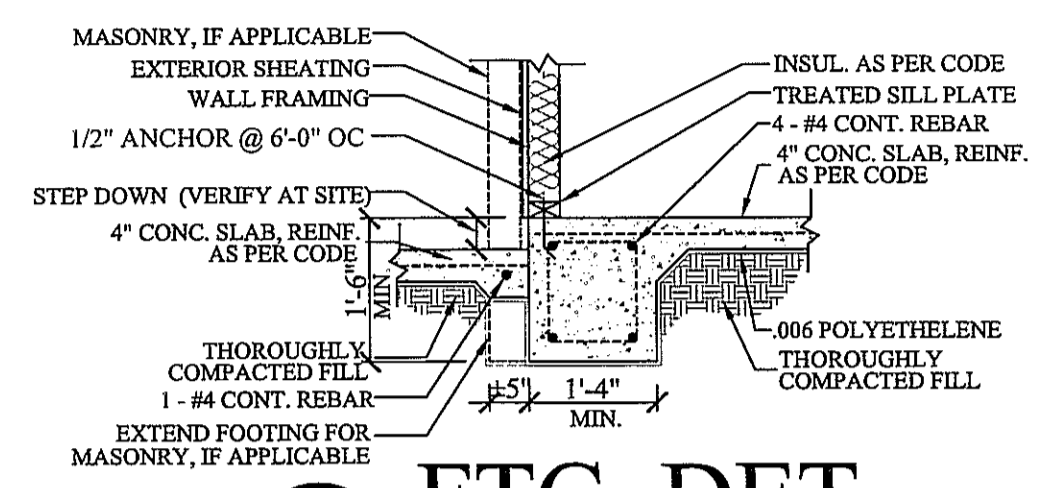

205 FTG. DET.

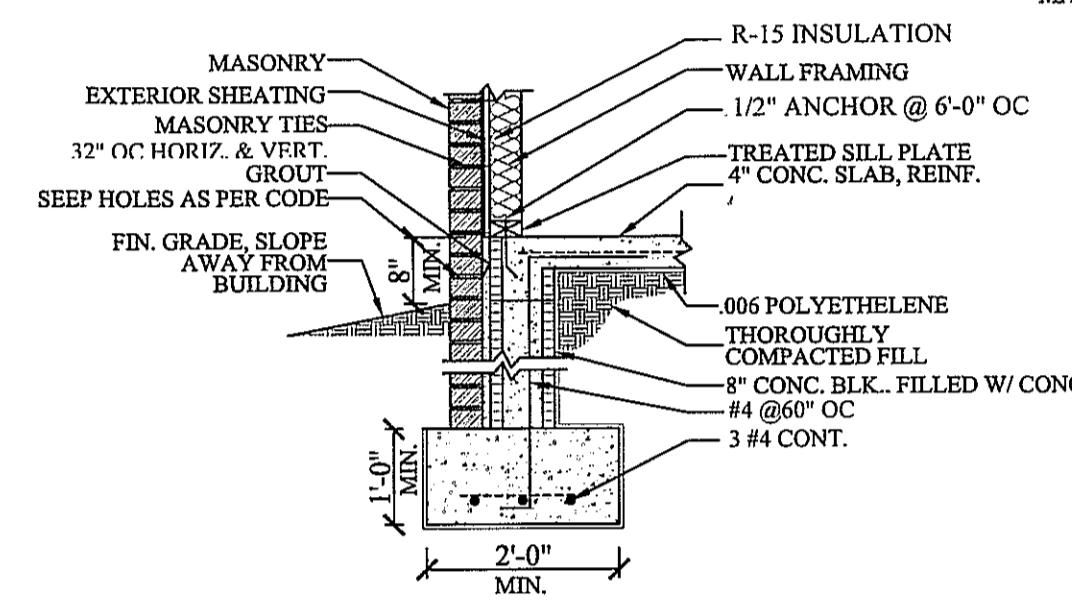

220 FTG. DET.

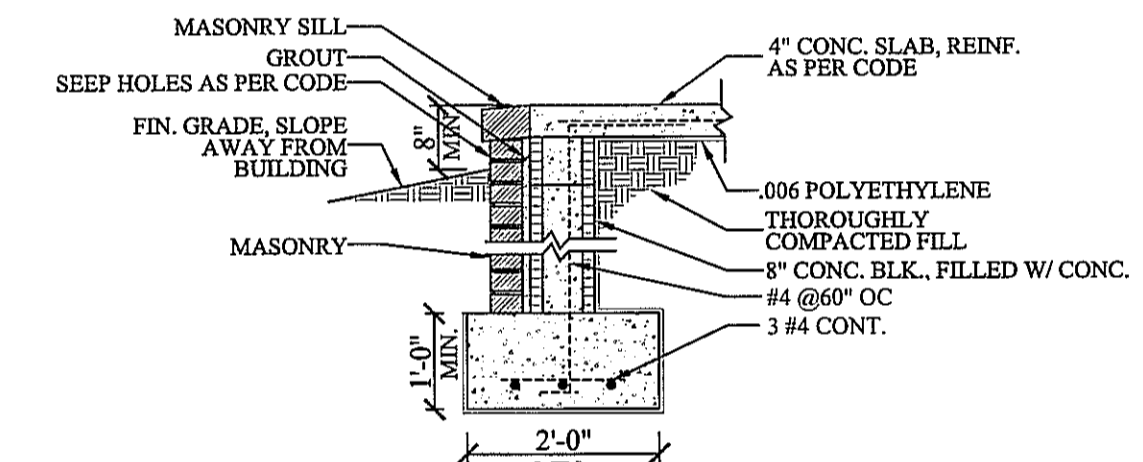

221 FTG. DET.

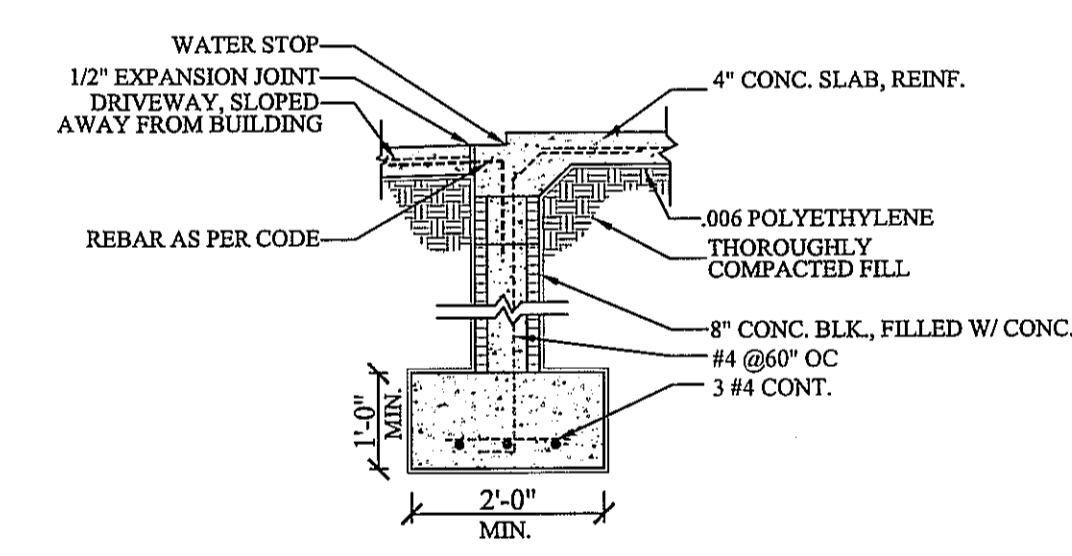

223 FTG. DET.

FOUNDATION NOTES:

- 1. FLOOR LIVE LOAD 40 PSF
2. ROOF LIVE 20 PSF
3. WF2.0 - 2'-0"WX16"D CONT. WALL FOOTING W/3 #4 OR 2 #5 CONT.
WF1.8 - 1'-8"WX16"D CONT. WALL FOOTING W/3 #4 OR 2 #5 CONT.
F3.0 - 36"X36"X12"D W/ 4 #4 EW
4. WALL: 2X4@16" OC
5. WOOD: SPF NO. 2 OR HIGHER
6. CONCRETE: f'c = 3000 PSI
7. MASONRY: f'm = 1500 PSI
8. ASSUMED SOIL BEARING: 2000 PSF
9. 4" CONCRETE SLAB ON GRADE CONCRETE W/6X6-W1.4XW1.4 REINFORCING OVER 6 MIL VAPOR BARRIER ON COMPACTED FILL
10. SLAB PERIMETER INSULATION: R-15 FOR 24"

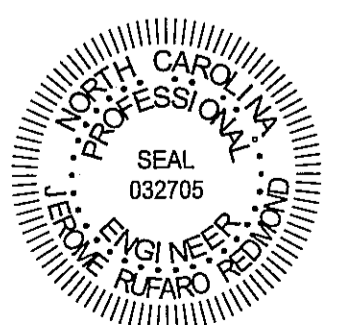

JEROME RUFARD REDMOND, PE BUILDING ENGINEERING & DESIGN 8209A MARKET ST. STE 222 WILMINGTON, NC 28411 P: 910.915.6529 JRUFARD@JUFARDAE.COM

MARK	DATE	REVISION

DESIGNED AND ENGINEERED BY
 JEROME RUFARO REDMOND, PE
 LICENSE NO. 002705
 STATE OF NORTH CAROLINA
 REGISTERED PROFESSIONAL ENGINEER
 IN THE MECHANICAL AND ELECTRICAL
 DISCIPLINES
 8209A MARKET STREET, STE. 222
 WILMINGTON, NC 28411
 910.915.6529
 JREDMOND5@YAHOO.COM

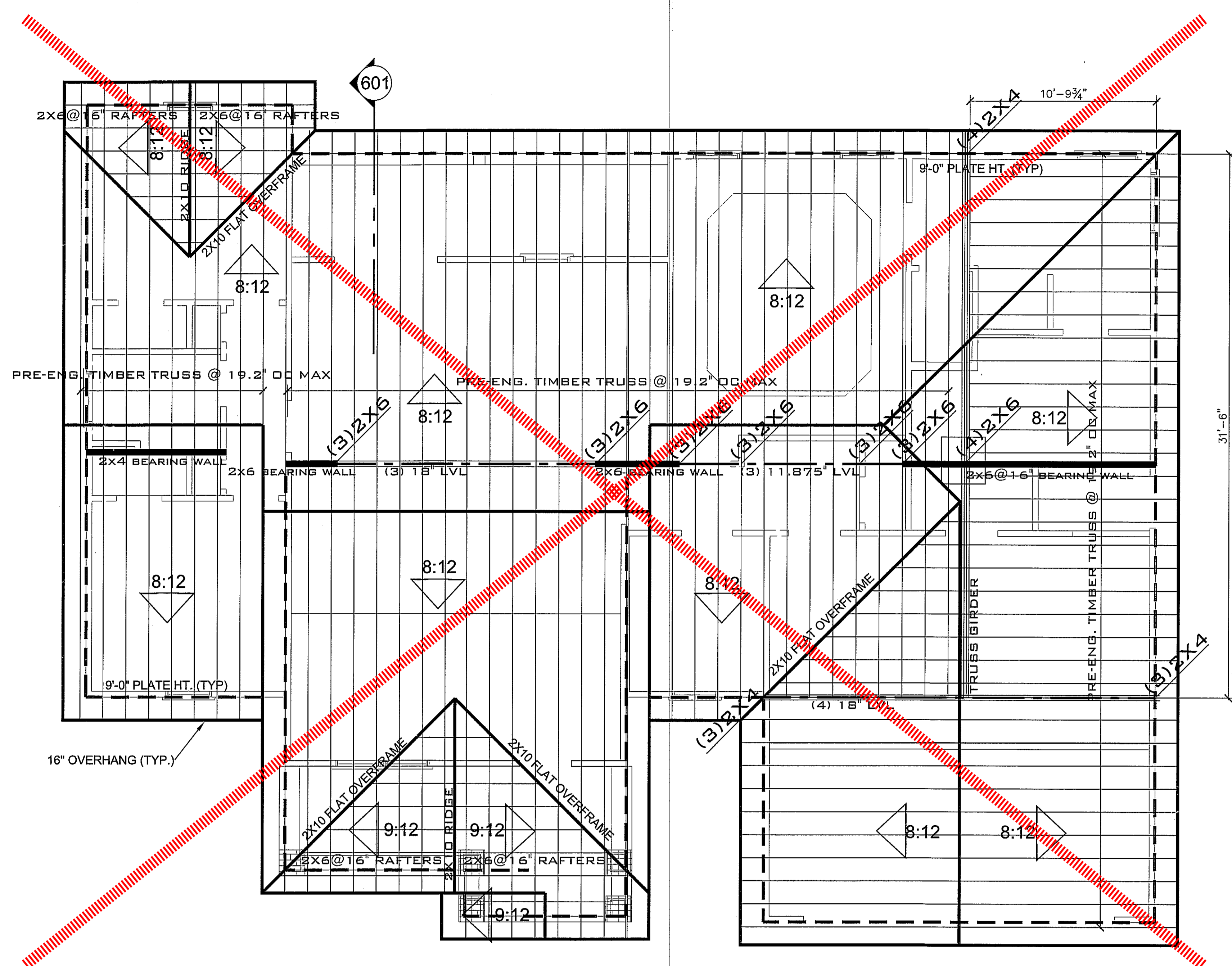

ROOF FRAMING PLAN

SCALE: 1/4" = 1'-0"
 NOTE:

1. ROOF LIVE LOAD 20 PSF
2. CEILING LIVE: 10 PSF ATTIC STORAGE: 20 PSF
3. WINDOW HEADER: (2)2X8 W/ 1 JACK AND 1 KING STUD SUPPORT
4. HEADERS TO BE (2) 2X8 HEADER UND
5. ATTIC INSULATION: R-42

TIMBER TRUSS

1. TRUSS FABRICATOR TO VERIFY FIELD DIMENSIONS WITH GENERAL CONTRACTOR.
2. ALL TIMBER TRUSSES SHALL BE DESIGNED FOR:
 - 110 MPH WIND SPEED
 - TOP CHORD LL = 30 PSF
 - TOP CHORD DL = 10 PSF
 - BOT CHORD LL = 20 PSF (GENERAL ATTIC)
 - BOT CHORD DL = 15 PSF
 - NET UPLIFT = 25 PSF
 IN ACCORDANCE WITH GOVERNING LOAD COMBINATIONS PER IBC 1605.
3. TRUSS SUPPLIER SHALL SUBMIT SHOP DRAWINGS WITH NORTH CAROLINA REGISTERED ENGINEER SEAL BEFORE FABRICATION.
4. ALL MEMBERS TO BE SYP NO. 2 OR HIGHER
5. PROVIDE ANCHORAGE AT ALL BEARING LOCATIONS
6. SEE SHEET 5 FOR CATHEDRAL CEILING PROFILE IN GREAT ROOM

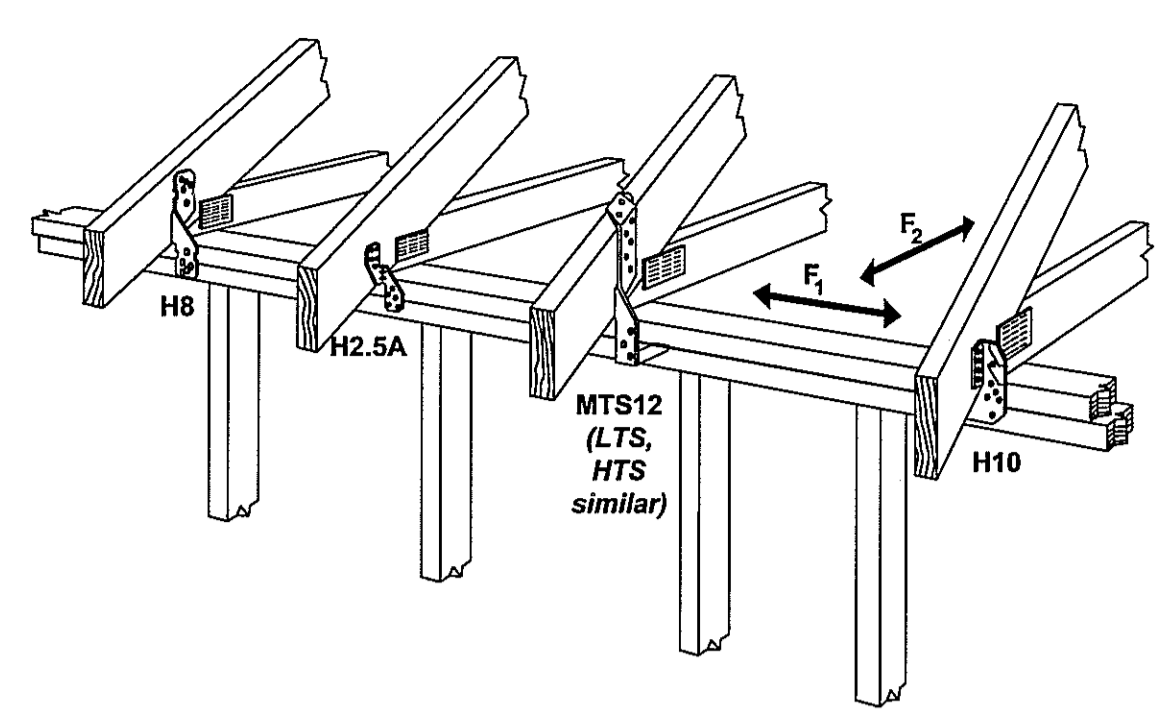

D30 DET HURRICANE TIE OPTIONS

NOTE: FASTENING SCHEDULE PER MANUFACTURER'S RECOMMENDATIONS

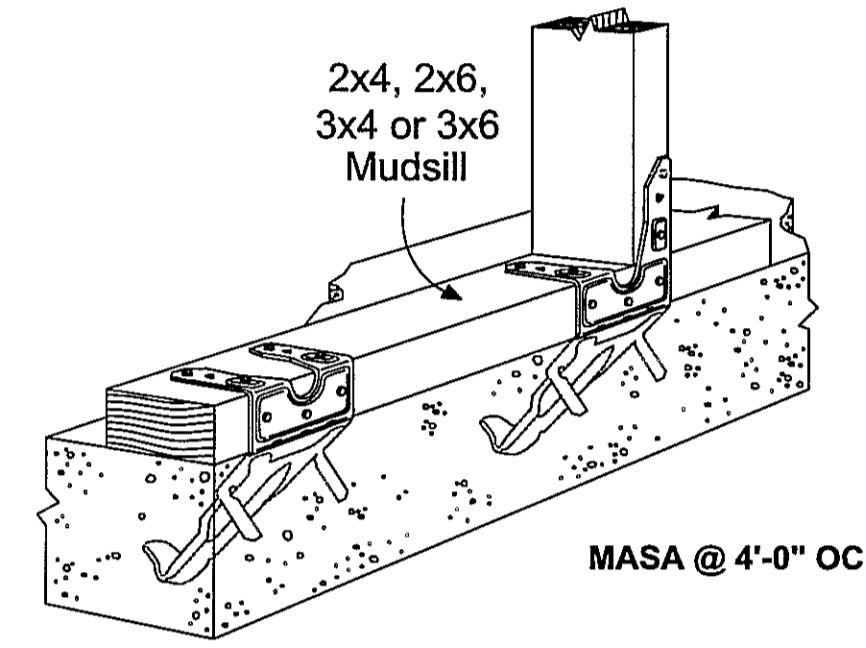

D32 DET ANCHORAGE - ALTERNATIVE

NOTE: FASTENING SCHEDULE PER MANUFACTURER'S RECOMMENDATIONS

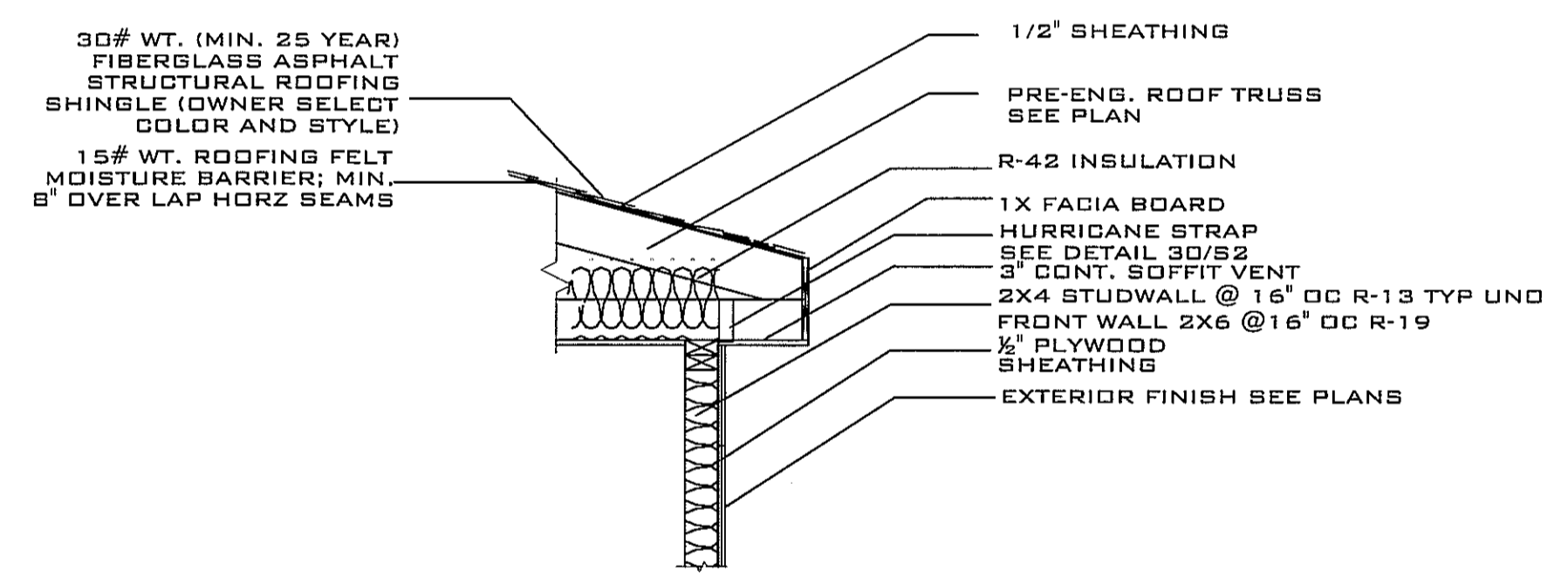

3 ROOF @ BEARING WALL DETAIL

SCALE: NTS

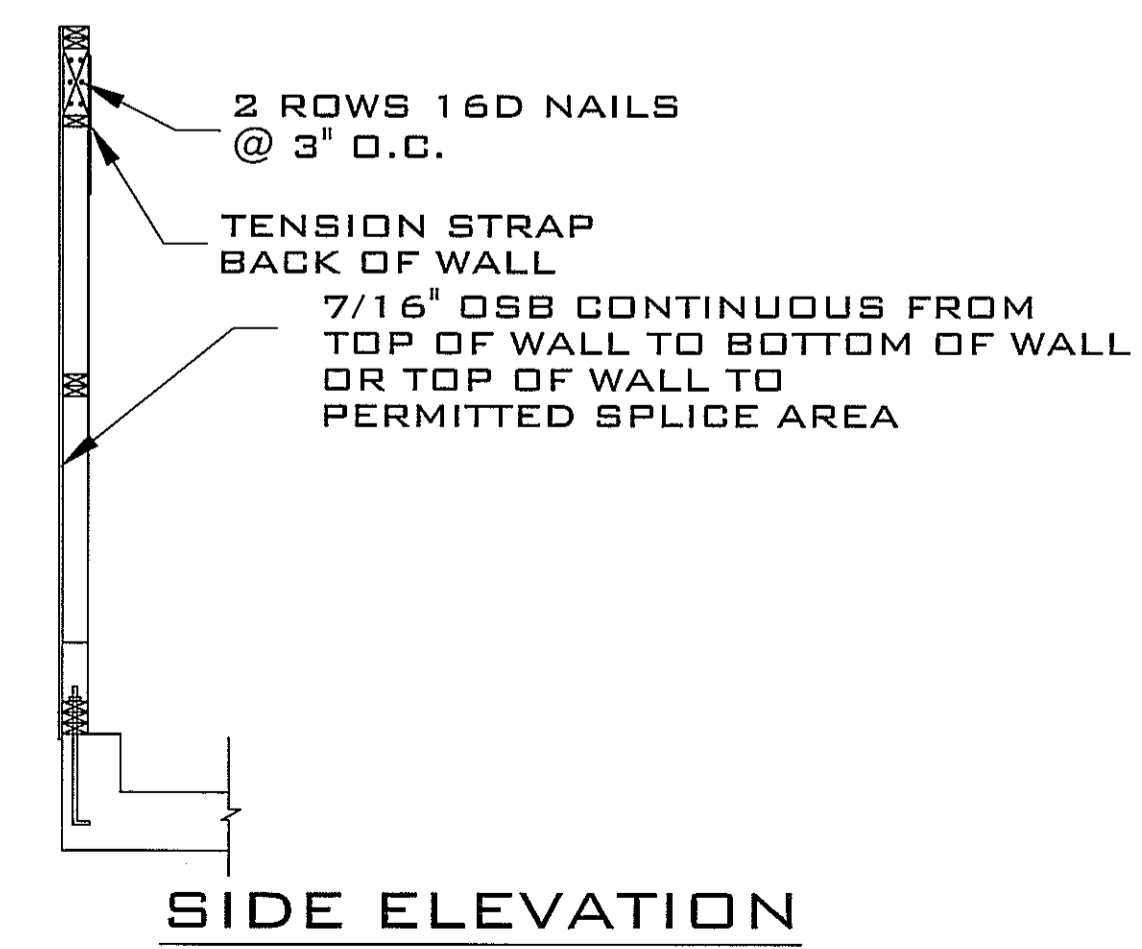

SIDE ELEVATION

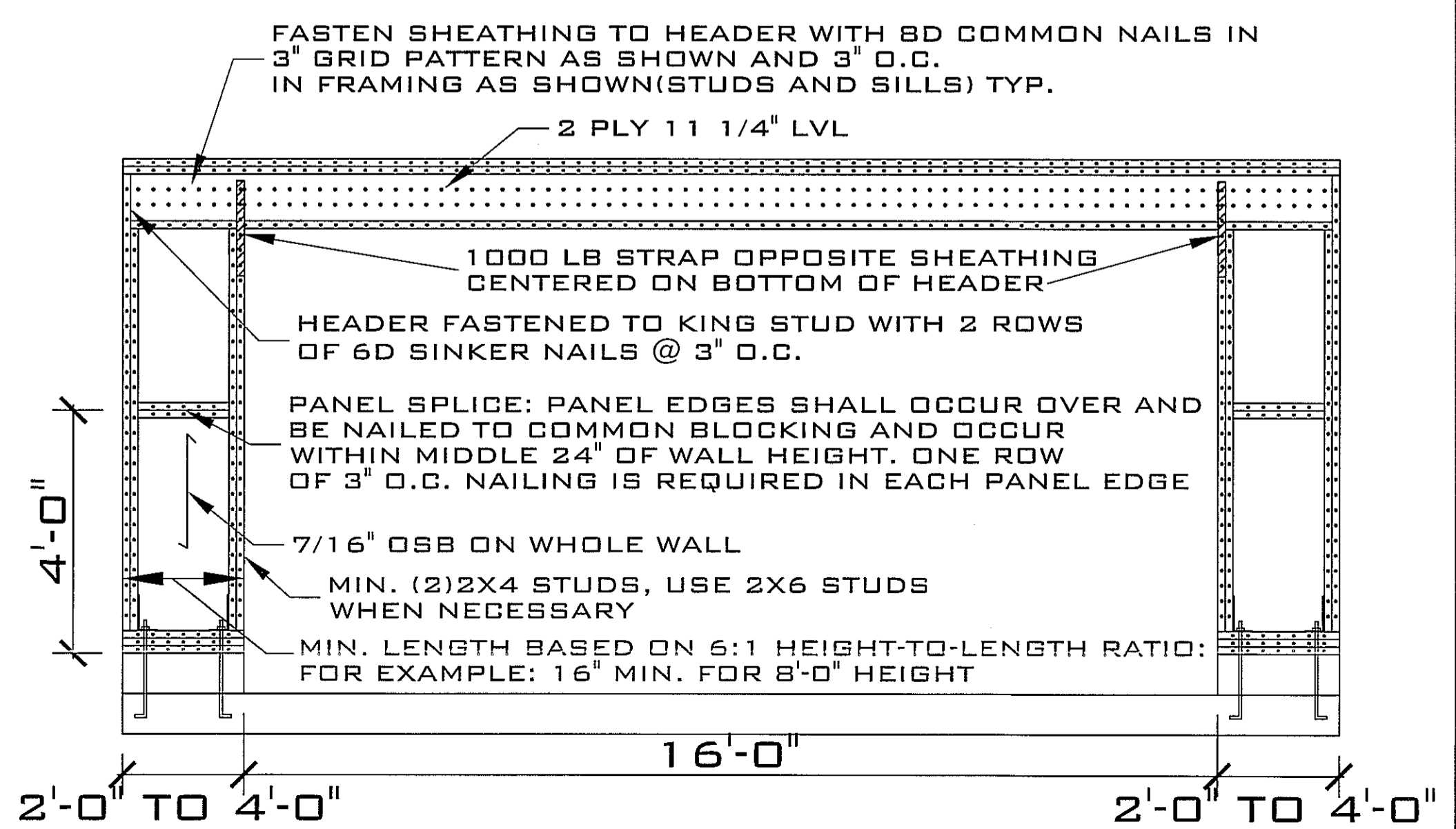

GARAGE PORTAL FRAME DETAIL

JEROME RUFARO REDMOND, PE
 BUILDING ENGINEERING & DESIGN
 8209A MARKET STREET, STE. 222
 WILMINGTON, NC 28411
 910.915.6529
 JREDMOND5@YAHOO.COM

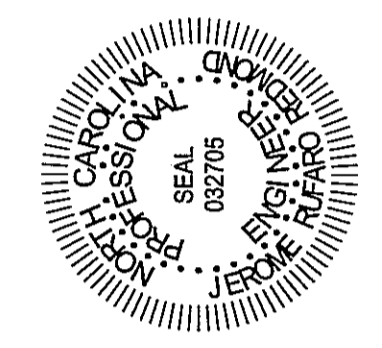

BB 1675-2 PLAN
HARNETT COUNTY, NC

DRAWING TITLE	
ROOF FRAMING PLAN AND STRUCTURAL DETAILS	
DRAWN BY:	JRR
CHECKED BY:	JRR
SCALE:	AS SHOWN
DATE:	06.02.19
PROJECT	SHEET
02019173	S2

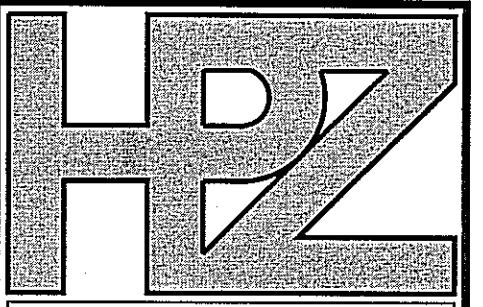

House Plan Zone, LLC

House Plan Zone, LLC. Email: HPZplans@comcast.net Fax: 1-800-574-1387



Plan ID:

BB-1675-2

Date: 06.06.13

Drawn By: C.T.B.

SHEET NUMBER

2

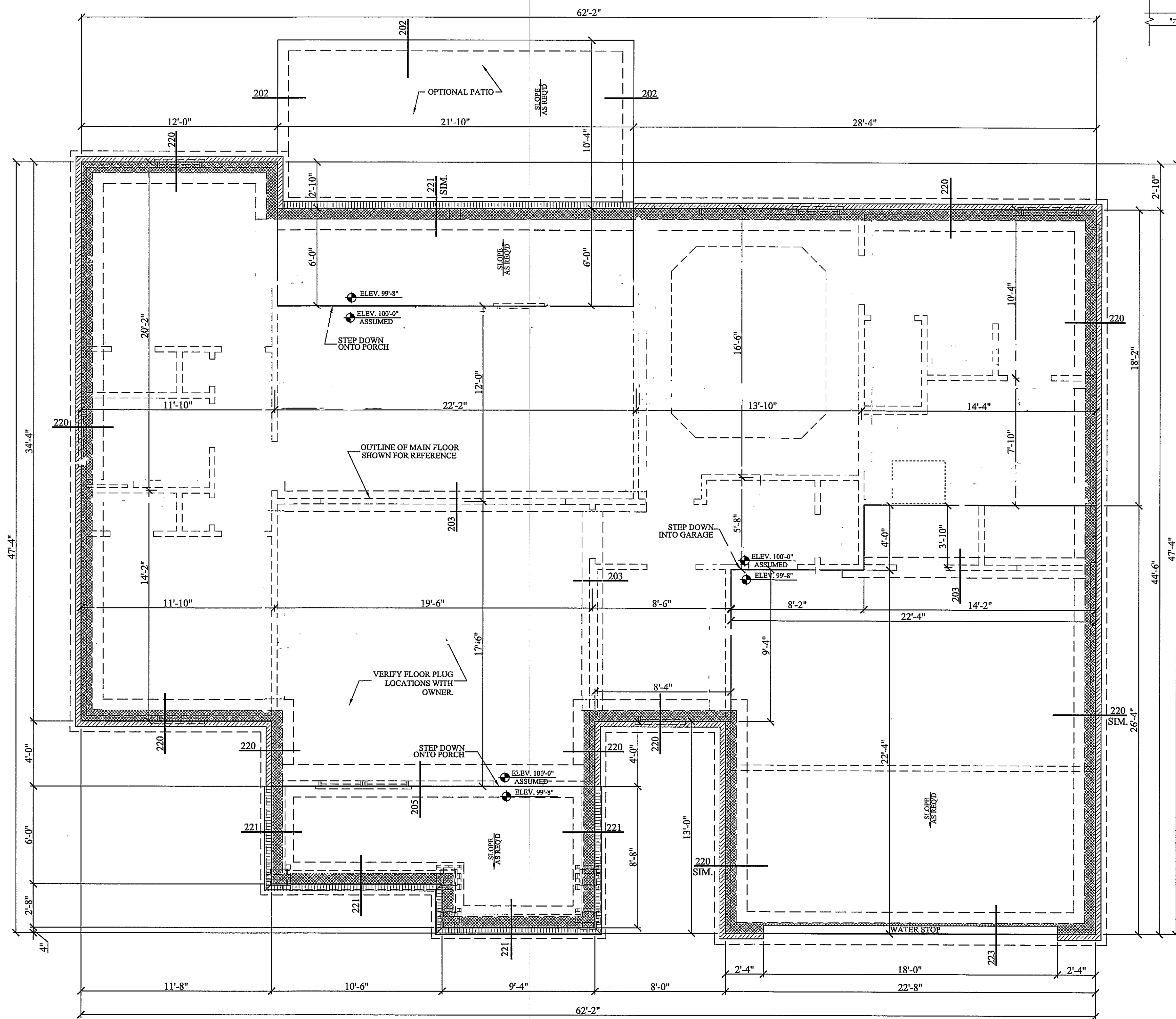

201 FOUNDATION PLAN SCALE: 1/4" = 1'-0"

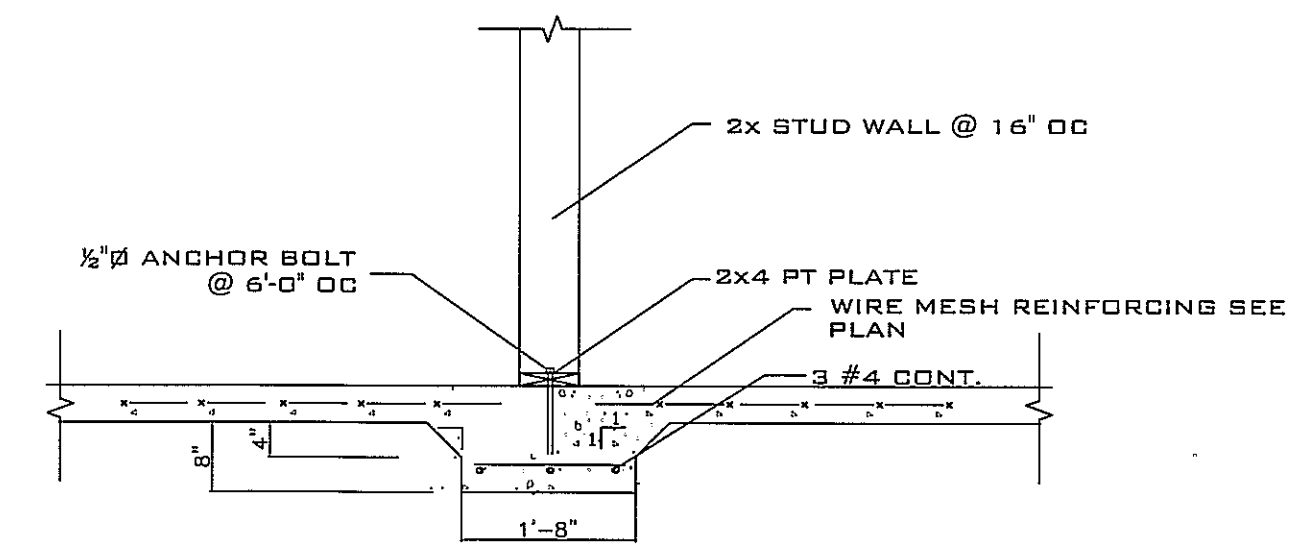

203 THICKENED SLAB SCALE: NTS

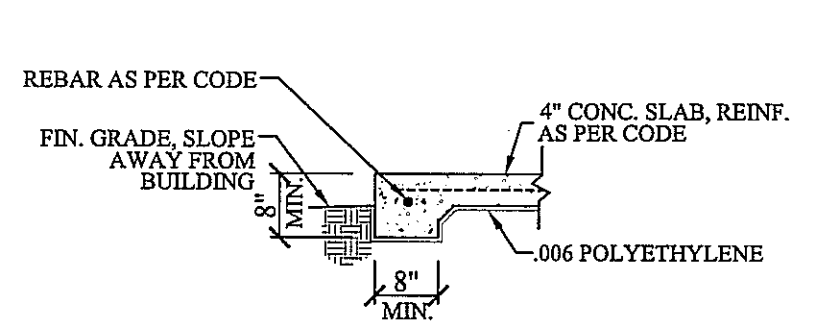

202 FTG. DET.

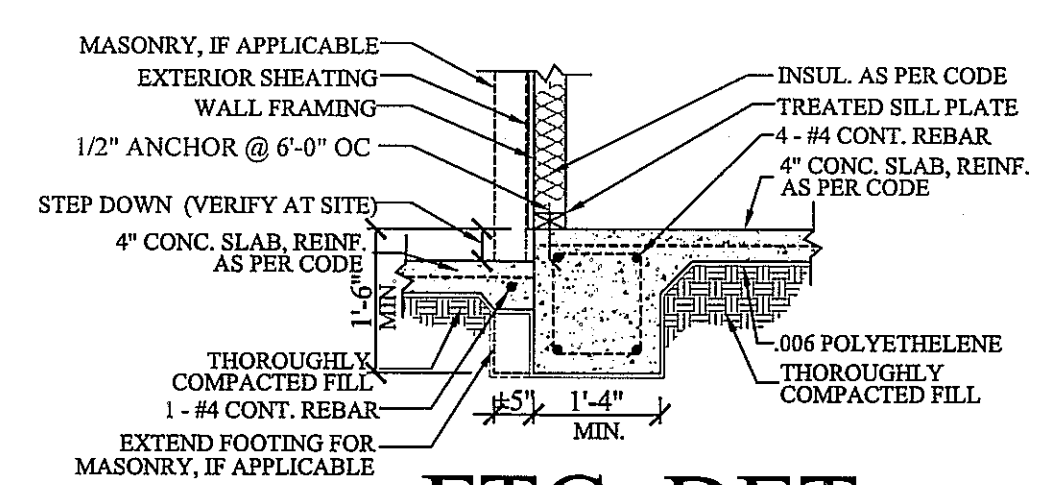

205 FTG. DET.

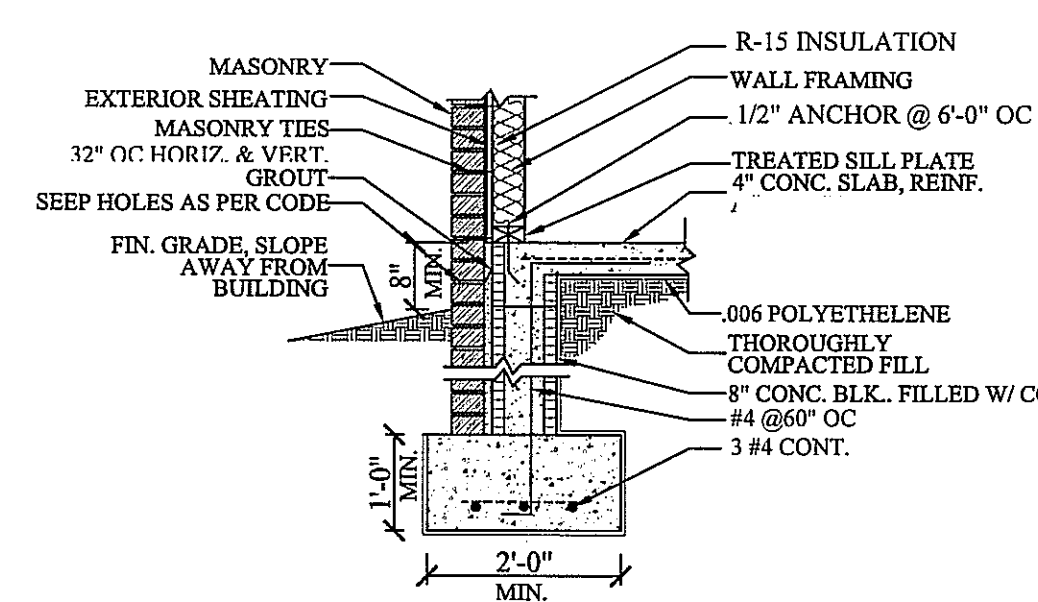

220 FTG. DET.

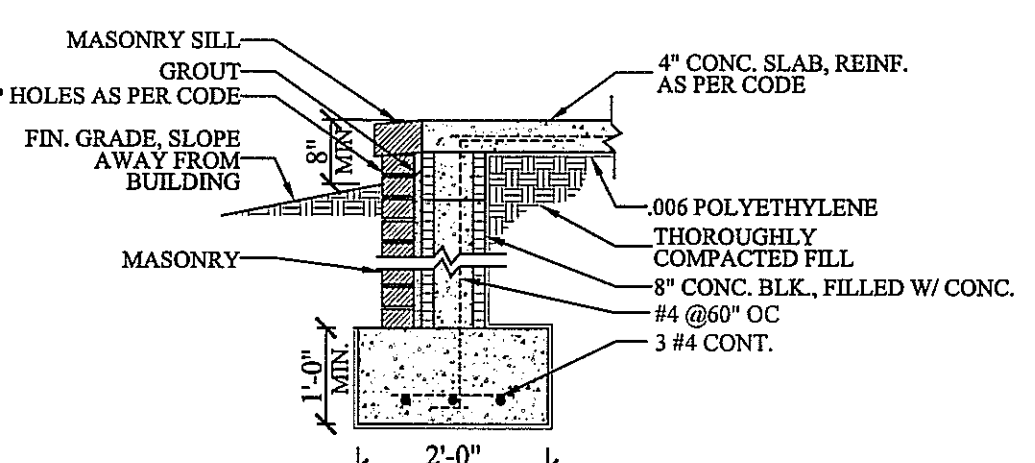

221 FTG. DET.

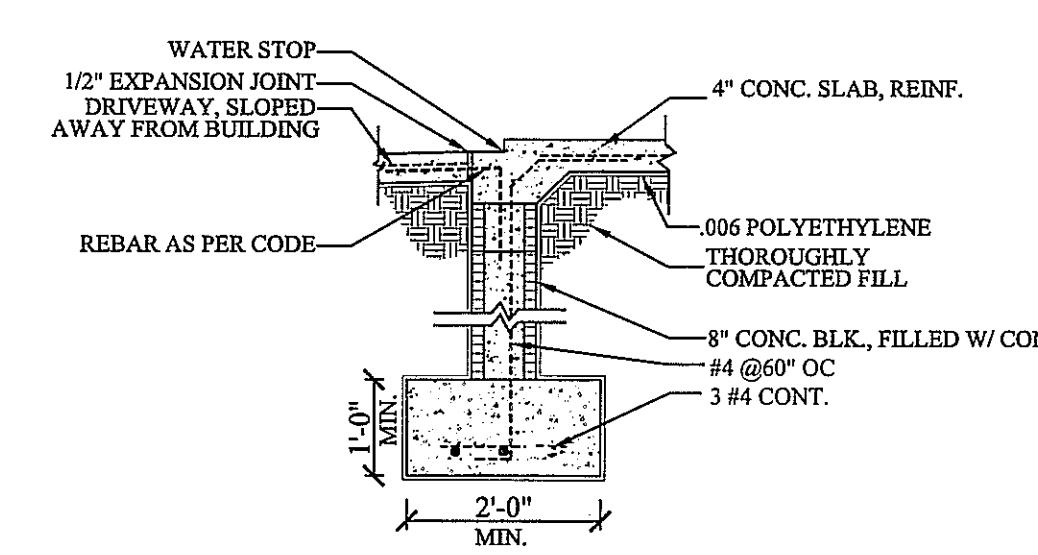

223 FTG. DET.

FOUNDATION NOTES:

1. FLOOR LIVE LOAD 40 PSF
2. ROOF LIVE 20 PSF
3. WF2.0 - 2'-0"WX16"D CONT. WALL FOOTING W/3 #4 OR 2 # 5 CONT.
- WF1.8 - 1'-8"WX16"D CONT. WALL FOOTING W/3 #4 OR 2 # 5 CONT.
- F3.0 - 36"X36"X12"D W/ 4 #4 EW
4. WALL: 2X4@16" OC
5. WOOD: SPF NO. 2 OR HIGHER
6. CONCRETE: F'c = 3000 PSI
7. MASONRY: F'm = 1500 PSI
8. ASSUMED SOIL BEARING: 2000 PSF
9. 4" CONCRETE SLAB ON GRADE CONCRETE W/6X6-W1.4XW1 4 REINFORCING OVER 6 MIL VAPOR BARRIER ON COMPACTED FILL
10. SLAB PERIMETER INSULATION: R-15 FOR 24"

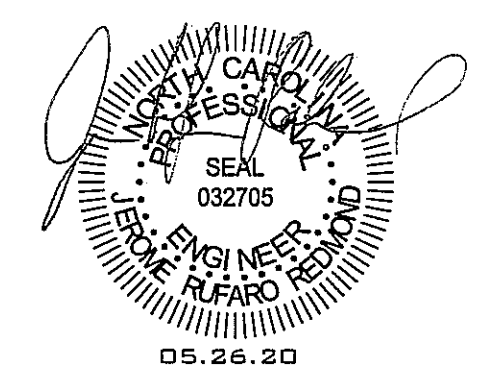

JEROME RUFARD REDMOND, PE BUILDING ENGINEERING & DESIGN 8209A MARKET ST. STE 222 WILMINGTON, NC 28411 P: 910.915.6529 JRUFARD@JRUFARDAE.COM

Floor Area: 0 SF
 Floor Plywood: 0
 Roof Area: 3779.14 SF
 Roof Plywood: 90 sheets
 Roof Shingles: 47 Squares

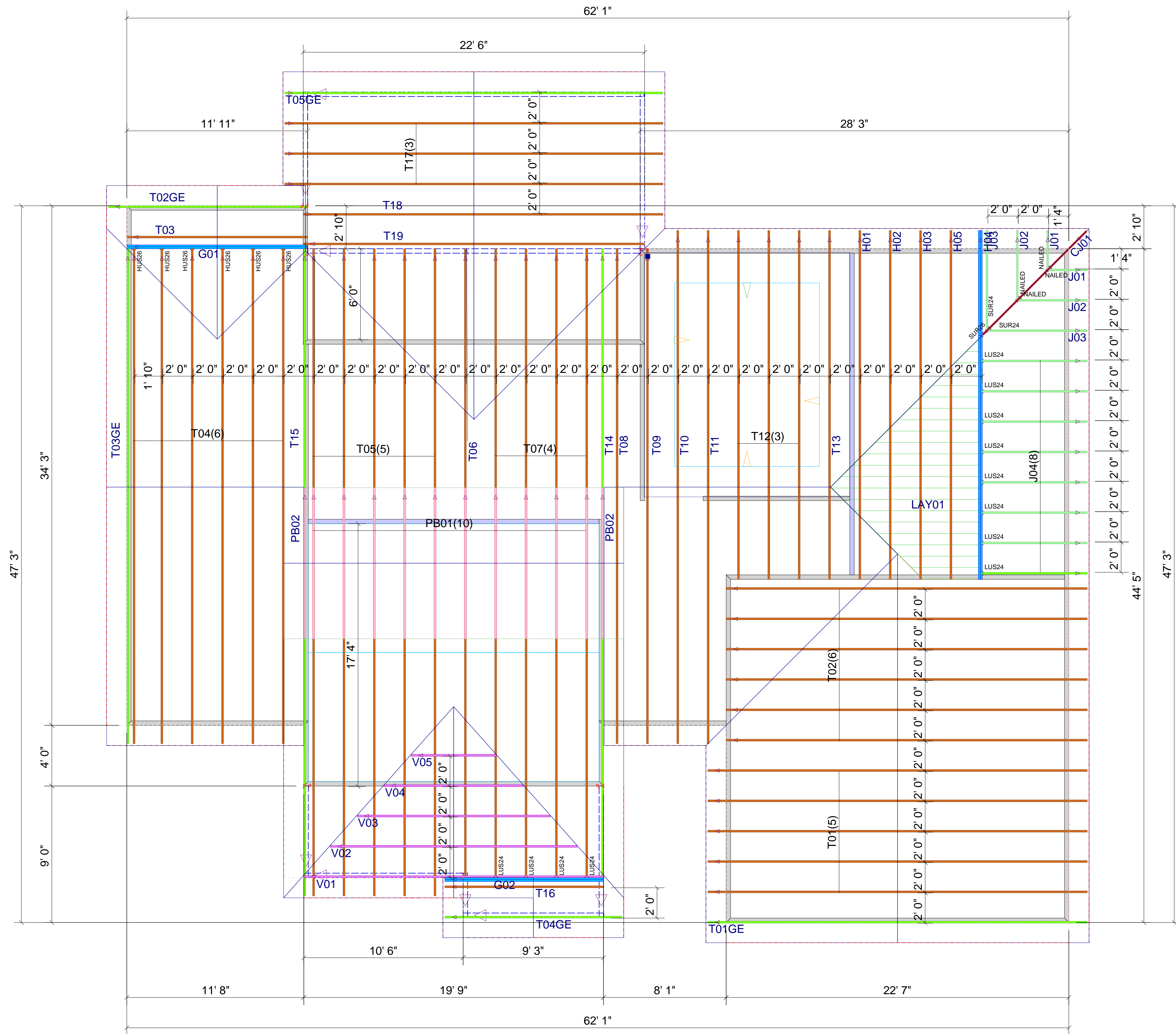

ROOF TRUSS LAYOUT

1/4" = 1'-0"

Client: J. E. WOMBLE AND SONS

Project: 802 IRI'S BRYANT RD

Model:

Lot #: Subdivision:

Order #: Designer:

Date: / /

P21-04008



4476 Hwy. 21 W
 West End, NC 27376
 (910) 673-4711

NOTE

IT IS THE RESPONSIBILITY OF THE BUILDING DESIGNER OR ARCHITECT TO PROVIDE AN APPROPRIATE CONNECTION FOR TRUSSES TO SUPPORTING STRUCTURE PERFECTIONS SHOWN ON TRUSS ENGINEERING SPECIAL CONSIDERATIONS FOR MECHANICAL EQUIPMENT AND/OR PLUMBING (AND THEIR CONNECTIONS) IN TRUSS SPACE MUST BE DIAGRAMMED BY BUILDER ON APPROVED TRUSS LAYOUT PRIOR TO FABRICATION.
 THIS COMPANY IS A TRUSS MANUFACTURER WHOSE RESPONSIBILITIES ARE LIMITED TO THOSE DESCRIBED IN WTCAL-1995 "DESIGN RESPONSIBILITIES". ACCORDINGLY, IT DISCLAIMS ANY RESPONSIBILITIES AND/OR LIABILITY FOR THE CONSTRUCTION, DESIGN, DRAWINGS, DOCUMENTS INCLUDING THE INSTALLATION AND BRACING OF TRUSSES MANUFACTURED BY THIS COMPANY. SEE <http://support.sbindustry.com/pubs/TTBDResp-D>