



Boise Cascade
www.bldr.com

1135 ROBESON STREET
FAYETTEVILLE, NC 28305
V (910) 485-1111

7601 BOEING DRIVE
GREENSBORO, NC 27409
V (336) 884-5454

3189 NC HIGHWAY 5
ABERDEEN NC 28315
V (910) 944-2516

This layout and associated materials list has been prepared based on project plans and/or information provided to Builders FirstSource (BFS). It remains the responsibility of the builder, architect, designer, or other responsible persons to review this information to assure that it is appropriate, accurate, complete and complies with applicable building codes.

- GENERAL NOTES:**
- 1.) READ THE INSTALLATION GUIDE BEFORE FRAMING.
 - 2.) ALL WALLS SHOWN ARE LOAD BEARING UNLESS NOTED OTHERWISE. WALLS NOT SHOWN ARE CONSIDERED NON-LOAD BEARING.
 - 3.) UNLESS STATED OTHERWISE ALL CEILING & ROOF LOADS BRACE DIRECTLY TO LOAD BEARING WALLS SUPPORTED BY FOUNDATION.
 - 4.) CONTACT BUILDERS FIRSTSOURCE BEFORE MAKING ANY ALTERATIONS OR ADJUSTMENTS...FAILURE TO DO SO MAY RESULT IN COSTLY REPAIRS.

A&G RESIDENTIAL
FRR010 CAMDEN L
2ND FLOOR EWP PLACEMENT PLAN
Builders FirstSource, Central Carolina Markets
DRAWN BY: AJ Napier DATE: 2/28/2021
JOB NUMBER:
SCALE: NTS

MINIMUM DESIGN DATA
LIVE LOAD 40 PSF
DEAD LOAD 10 PSF

TOTAL LOAD 50 PSF
DOL = 100%

DEFLECTION CRITERIA
L/480 (MINIMUM)

ARCHITECTURAL PLAN DATE
XX-XX-XX

REVISED ARCH. PLAN DATE
XX-XX-XX

SD011619

Sheet
1 of 1

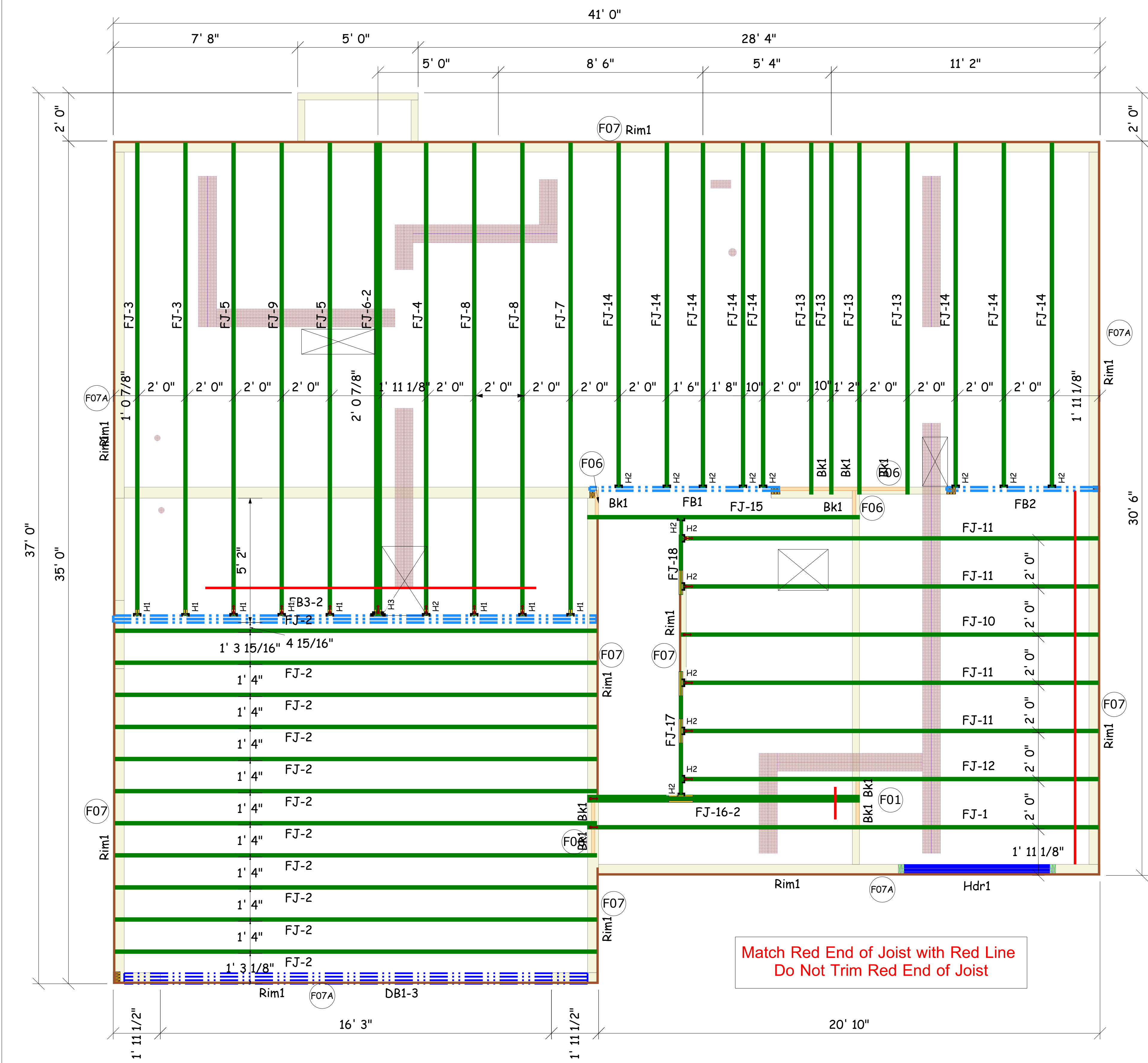
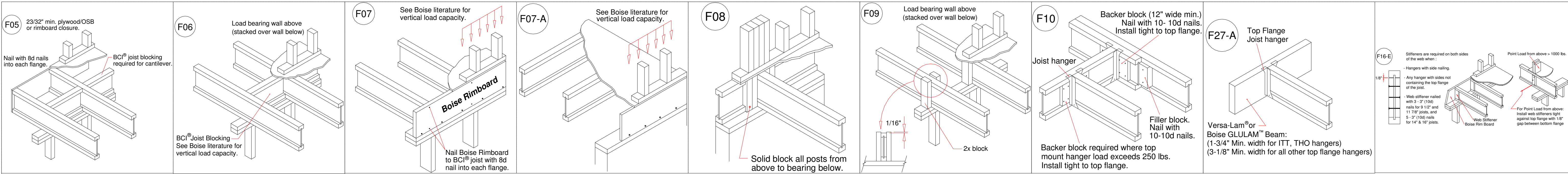

Match Red End of Joist with Red Line
Do Not Trim Red End of Joist

Products					
PlotID	Length	Product	Plies	Net Qty	Fab Type
FJ-1	21' 2 1/2"	14" BCI® 4500s-1.8	1	1	FF
FJ-2	20' 0"	14" BCI® 4500s-1.8	1	11	FF
FJ-3	19' 7 3/4"	14" BCI® 4500s-1.8	1	2	FF
FJ-4	19' 7 3/4"	14" BCI® 4500s-1.8	1	1	FF
FJ-5	19' 7 3/4"	14" BCI® 4500s-1.8	1	2	FF
FJ-6-2	19' 7 3/4"	14" BCI® 4500s-1.8	2	2	FF
FJ-7	19' 7 1/2"	14" BCI® 4500s-1.8	1	1	FF
FJ-8	19' 7 1/2"	14" BCI® 4500s-1.8	1	2	FF
FJ-9	19' 7 1/2"	14" BCI® 4500s-1.8	1	1	FF
FJ-10	17' 4"	14" BCI® 4500s-1.8	1	1	FF
FJ-11	17' 3 1/4"	14" BCI® 4500s-1.8	1	4	FF
FJ-12	17' 3 1/4"	14" BCI® 4500s-1.8	1	1	FF
FJ-13	14' 7"	14" BCI® 4500s-1.8	1	4	FF
FJ-14	14' 3 1/2"	14" BCI® 4500s-1.8	1	8	FF
FJ-15	11' 3 1/2"	14" BCI® 4500s-1.8	1	1	FF
FJ-16-2	11' 3 1/2"	14" BCI® 4500s-1.8	2	2	FF
FJ-17	5' 1 1/2"	14" BCI® 4500s-1.8	1	1	FF
FJ-18	3' 1 3/4"	14" BCI® 4500s-1.8	1	1	FF
DB1-3	20' 0"	1-3/4" x 11-7/8" VERSA-LAM® 2.0 3100 SP	3	3	FF
FB1	8' 0"	1-3/4" x 14" VERSA-LAM® 2.0 3100 SP	1	1	FF
FB2	7' 0"	1-3/4" x 14" VERSA-LAM® 2.0 3100 SP	1	1	FF
FB3-2	22' 0"	1-3/4" x 16" VERSA-LAM® 2.0 3100 SP	2	2	FF
Rim1	12' 0"	1" x 14" BC RIM BOARD OSB	1	14	FF
Bk1	11' 0"	14" BCI® 4500s-1.8	1	1	FF

Wall Framing					
PlotID	Length	Product	Plies	Net Qty	Fab Type
Hdr1	8' 0"	1-3/4" x 9-1/4" VERSA-LAM® 2.0 3100 SP	2	2	MFD

Hangers			
PlotID	Qty	Manuf	Product
H1	8	Simpson	HU14
H2	16	Simpson	IUS1.81/14
H3	1	Simpson	MIU3.56/14

CAMDEN
2nd FLOOR I-JOIST LAYOUT