

RE: J1220-5672
Lot 31 Forest Ridge

Trenco
818 Soundside Rd
Edenton, NC 27932

Site Information:

Customer: Project Name: J1220-5672
Lot/Block: Model:
Address: Subdivision:
City: State:

General Truss Engineering Criteria & Design Loads (Individual Truss Design Drawings Show Special Loading Conditions):

Design Code: IRC2015/TPI2014 Design Program: MiTek 20/20 8.3
Wind Code: N/A Wind Speed: N/A mph
Roof Load: N/A psf Floor Load: 55.0 psf

This package includes 13 individual, dated Truss Design Drawings and 0 Additional Drawings.

No.	Seal#	Truss Name	Date
1	E14305209	ET1	1/7/2021
2	E14305210	ET2	1/7/2021
3	E14305211	F1	1/7/2021
4	E14305212	F2	1/7/2021
5	E14305213	F2A	1/7/2021
6	E14305214	F3	1/7/2021
7	E14305215	F4	1/7/2021
8	E14305216	F4A	1/7/2021
9	E14305217	F5	1/7/2021
10	E14305218	F6	1/7/2021
11	E14305219	F7	1/7/2021
12	E14305220	FG1	1/7/2021
13	E14305221	FG2	1/7/2021

The truss drawing(s) referenced above have been prepared by Truss Engineering Co. under my direct supervision based on the parameters provided by Comtech, Inc - Fayetteville.

Truss Design Engineer's Name: Gilbert, Eric

My license renewal date for the state of North Carolina is December 31, 2021.

North Carolina COA: C-0844

IMPORTANT NOTE: The seal on these truss component designs is a certification that the engineer named is licensed in the jurisdiction(s) identified and that the designs comply with ANSI/TPI 1. These designs are based upon parameters shown (e.g., loads, supports, dimensions, shapes and design codes), which were given to TRENCO. Any project specific information included is for TRENCO customers file reference purpose only, and was not taken into account in the preparation of these designs. TRENCO has not independently verified the applicability of the design parameters or the designs for any particular building. Before use, the building designer should verify applicability of design parameters and properly incorporate these designs into the overall building design per ANSI/TPI 1, Chapter 2.



January 07, 2021

Job J1220-5672	Truss ET1	Truss Type Floor Supported Gable	Qty 1	Ply 1	Lot 31 Forest Ridge Job Reference (optional)	E14305209
-------------------	--------------	-------------------------------------	----------	----------	---	-----------

Comtech, Inc, Fayetteville, NC - 28314,

8.330 s Mar 23 2020 MiTek Industries, Inc. Thu Apr 16 14:03:04 2020 Page 1
ID:J6aSr?qB6etazEy6hKRskZzPTZ_-8e9c3elmFH5OOJ7cEOUt?nvVTkX855eZj55VTizQ76L

0-1-8

0-1-8

Scale = 1:50.0

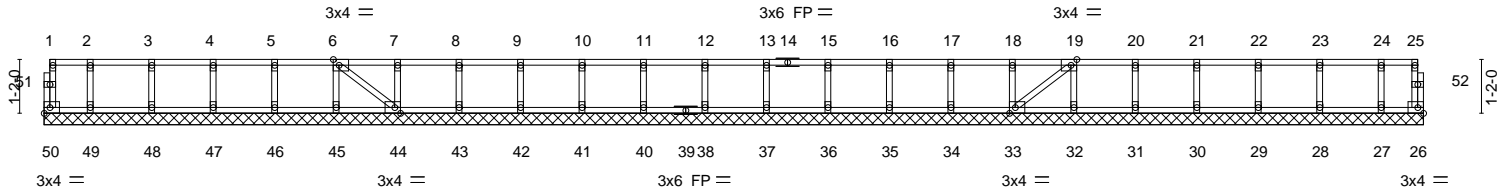

29-11-0
29-11-0

Plate Offsets (X,Y)-- [6:0-1-8,Edge], [19:0-1-8,Edge], [33:0-1-8,Edge], [44:0-1-8,Edge]

LOADING (psf)	SPACING-	CSL.	DEFL.	in (loc)	l/defl	L/d	PLATES	GRIP
TCLL 40.0	Plate Grip DOL 1.00	TC 0.06	Vert(LL) n/a	-	n/a	999	MT20	244/190
TCDL 10.0	Lumber DOL 1.00	BC 0.01	Vert(CT) n/a	-	n/a	999		
BCLL 0.0	Rep Stress Incr YES	WB 0.03	Horz(CT) -0.00	33	n/a	n/a		
BCDL 5.0	Code IRC2015/TPI2014	Matrix-S					Weight: 128 lb	FT = 20%F, 11%E

LUMBER-
TOP CHORD 2x4 SP No.1(flat)
BOT CHORD 2x4 SP No.1(flat)
WEBS 2x4 SP No.3(flat)
OTHERS 2x4 SP No.3(flat)

BRACING-
TOP CHORD Structural wood sheathing directly applied or 6-0-0 oc purlins, except end verticals.
BOT CHORD Rigid ceiling directly applied or 6-0-0 oc bracing.

REACTIONS. All bearings 29-11-0.
(lb) - Max Grav All reactions 250 lb or less at joint(s) 50, 26, 49, 48, 47, 46, 45, 44, 43, 42, 41, 40, 38, 37, 36, 35, 34, 33, 32, 31, 30, 29, 28, 27

FORCES. (lb) - Max. Comp./Max. Ten. - All forces 250 (lb) or less except when shown.

- NOTES-**
- 1) All plates are 1.5x3 MT20 unless otherwise indicated.
 - 2) Plates checked for a plus or minus 1 degree rotation about its center.
 - 3) Gable requires continuous bottom chord bearing.
 - 4) Truss to be fully sheathed from one face or securely braced against lateral movement (i.e. diagonal web).
 - 5) Gable studs spaced at 1-4-0 oc.
 - 6) Recommend 2x6 strongbacks, on edge, spaced at 10-0-0 oc and fastened to each truss with 3-10d (0.131" X 3") nails. Strongbacks to be attached to walls at their outer ends or restrained by other means.

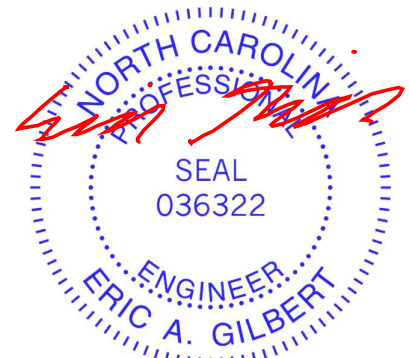

April 16, 2020

WARNING - Verify design parameters and READ NOTES ON THIS AND INCLUDED MITEK REFERENCE PAGE MII-7473 rev. 5/19/2020 BEFORE USE.

Design valid for use only with MiTek® connectors. This design is based only upon parameters shown, and is for an individual building component, not a truss system. Before use, the building designer must verify the applicability of design parameters and properly incorporate this design into the overall building design. Bracing indicated is to prevent buckling of individual truss web and/or chord members only. Additional temporary and permanent bracing is always required for stability and to prevent collapse with possible personal injury and property damage. For general guidance regarding the fabrication, storage, delivery, erection and bracing of trusses and truss systems, see

ANSI/TPI1 Quality Criteria, DSB-89 and BCSI Building Component

Safety Information available from Truss Plate Institute, 2670 Crain Highway, Suite 203 Waldorf, MD 20601



818 Soundside Road
Edenton, NC 27932

Job J1220-5672	Truss ET2	Truss Type GABLE	Qty 1	Ply 1	Lot 31 Forest Ridge	E14305210
					Job Reference (optional)	

Comtech, Inc, Fayetteville, NC - 28314,

8.330 s Mar 23 2020 MiTek Industries, Inc. Thu Apr 16 14:03:06 2020 Page 1
ID:J6aSr?qB6etazEy6hKRSkZzPTZ_-51HNUKK0nuL6dcH_LpXL4C?rwYDcZ?6sAPabYazQ76J

0-1-8

Scale = 1:41.7

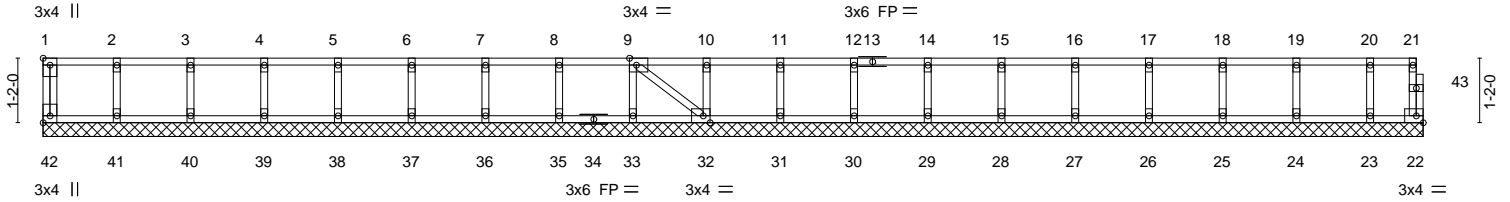

24-11-8

24-11-8

Plate Offsets (X,Y)-- [1:Edge,0-1-8], [9:0-1-8,Edge], [32:0-1-8,Edge], [42:Edge,0-1-8]

LOADING (psf)	SPACING-	CSL.	DEFL.	in (loc)	l/defl	L/d	PLATES	GRIP
TCLL 40.0	Plate Grip DOL 1.00	TC 0.06	Vert(LL) n/a	-	n/a	999	MT20	244/190
TCDL 10.0	Lumber DOL 1.00	BC 0.01	Vert(CT) n/a	-	n/a	999		
BCLL 0.0	Rep Stress Incr YES	WB 0.03	Horz(CT) 0.00	22	n/a	n/a		
BCDL 5.0	Code IRC2015/TPI2014	Matrix-S						
							Weight: 106 lb	FT = 20%F, 11%E

LUMBER-
TOP CHORD 2x4 SP No.1(flat)
BOT CHORD 2x4 SP No.1(flat)
WEBS 2x4 SP No.3(flat)
OTHERS 2x4 SP No.3(flat)

BRACING-
TOP CHORD Structural wood sheathing directly applied or 6-0-0 oc purlins, except end verticals.
BOT CHORD Rigid ceiling directly applied or 10-0-0 oc bracing.

REACTIONS. All bearings 24-11-8.
(lb) - Max Grav All reactions 250 lb or less at joint(s) 42, 22, 41, 40, 39, 38, 37, 36, 35, 33, 32, 31, 30, 29, 28, 27, 26, 25, 24, 23

FORCES. (lb) - Max. Comp./Max. Ten. - All forces 250 (lb) or less except when shown.

- NOTES-**
- 1) All plates are 1.5x3 MT20 unless otherwise indicated.
 - 2) Plates checked for a plus or minus 1 degree rotation about its center.
 - 3) Gable requires continuous bottom chord bearing.
 - 4) Truss to be fully sheathed from one face or securely braced against lateral movement (i.e. diagonal web).
 - 5) Gable studs spaced at 1-4-0 oc.
 - 6) Recommend 2x6 strongbacks, on edge, spaced at 10-0-0 oc and fastened to each truss with 3-10d (0.131" X 3") nails. Strongbacks to be attached to walls at their outer ends or restrained by other means.
 - 7) CAUTION, Do not erect truss backwards.

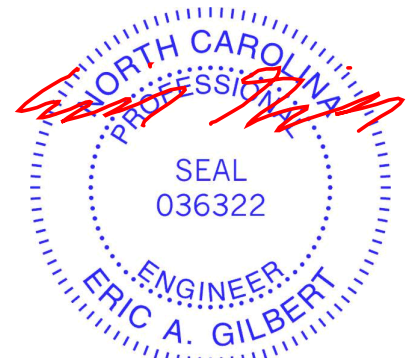

April 16, 2020

WARNING - Verify design parameters and READ NOTES ON THIS AND INCLUDED MITEK REFERENCE PAGE MII-7473 rev. 5/19/2020 BEFORE USE.

Design valid for use only with MiTek® connectors. This design is based only upon parameters shown, and is for an individual building component, not a truss system. Before use, the building designer must verify the applicability of design parameters and properly incorporate this design into the overall building design. Bracing indicated is to prevent buckling of individual truss web and/or chord members only. Additional temporary and permanent bracing is always required for stability and to prevent collapse with possible personal injury and property damage. For general guidance regarding the fabrication, storage, delivery, erection and bracing of trusses and truss systems, see

ANSI/TPI1 Quality Criteria, DSB-89 and BCSI Building Component

Safety Information available from Truss Plate Institute, 2670 Crain Highway, Suite 203 Waldorf, MD 20601



818 Soundside Road
Edenton, NC 27932

Job J1220-5672	Truss F1	Truss Type Floor	Qty 8	Ply 1	Lot 31 Forest Ridge Job Reference (optional)	E14305211
-------------------	-------------	---------------------	----------	----------	---	-----------

Comtech, Inc, Fayetteville, NC - 28314,

8.330 s Mar 23 2020 MiTek Industries, Inc. Thu Apr 16 14:03:08 2020 Page 1
ID:J6aSr?qB6etazEy6hKRskZzPTZ_-1QP7v0LHVcqtWQNTDZp9d4_?Liu1l_9dj3icTzQ76H

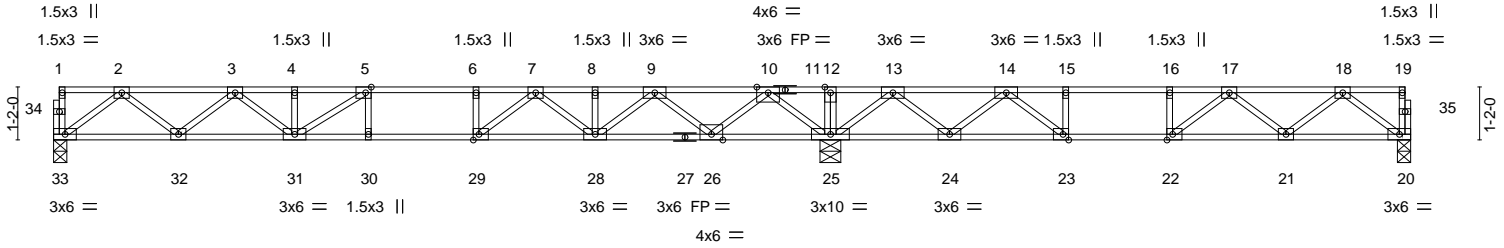

Plate Offsets (X,Y)--	[5:0-1-8,Edge], [22:0-1-8,Edge], [23:0-1-8,Edge], [29:0-1-8,Edge]
-----------------------	---

LOADING (psf)	SPACING-	2-0-0	CSI.	DEFL.	in (loc)	l/defl	L/d	PLATES	GRIP
TCLL 40.0	Plate Grip DOL	1.00	TC 0.86	Vert(LL)	-0.20	30	>999	MT20	244/190
TCDL 10.0	Lumber DOL	1.00	BC 0.85	Vert(CT)	-0.28	30	>735		
BCLL 0.0	Rep Stress Incr	YES	WB 0.58	Horz(CT)	0.05	20	n/a		
BCDL 5.0	Code	IRC2015/TPI2014	Matrix-S						
								Weight: 149 lb	FT = 20%F, 11%E

LUMBER-	BRACING-
TOP CHORD 2x4 SP No.1(flat)	TOP CHORD Structural wood sheathing directly applied or 6-0-0 oc purlins, except end verticals.
BOT CHORD 2x4 SP No.1(flat)	BOT CHORD Rigid ceiling directly applied or 6-0-0 oc bracing.
WEBS 2x4 SP No.3(flat)	

REACTIONS. (size) 33=0-3-8, 25=0-5-8, 20=0-3-8
Max Grav 33=826(LC 3), 25=1934(LC 1), 20=608(LC 4)

FORCES. (lb) - Max. Comp./Max. Ten. - All forces 250 (lb) or less except when shown.

TOP CHORD 2-3=-1695/0, 3-4=-2732/0, 4-5=-2732/0, 5-6=-2963/0, 6-7=-2963/0, 7-8=-2067/0, 8-9=-2067/0, 9-10=-539/303, 10-12=0/2152, 12-13=0/2152, 13-14=-551/972, 14-15=-1575/269, 15-16=-1575/269, 16-17=-1575/269, 17-18=-1162/0

BOT CHORD 32-33=0/1030, 31-32=0/2330, 30-31=0/2963, 29-30=0/2963, 28-29=0/2561, 26-28=-37/1417, 25-26=-833/0, 24-25=-1263/0, 23-24=-662/1135, 22-23=-269/1575, 21-22=-24/1515, 20-21=0/747

WEBS 2-33=-1290/0, 2-32=0/866, 3-32=-826/0, 3-31=0/514, 10-25=-1655/0, 10-26=0/1228, 9-26=-1188/0, 9-28=0/878, 7-28=-685/0, 7-29=0/807, 6-29=-359/0, 5-31=-475/153, 13-25=-1321/0, 13-24=0/882, 14-24=-926/0, 14-23=0/942, 18-20=-935/0, 18-21=0/540, 17-21=-460/99, 17-22=-345/76, 15-23=-417/0

- NOTES-**
- 1) Unbalanced floor live loads have been considered for this design.
 - 2) All plates are 3x4 MT20 unless otherwise indicated.
 - 3) Plates checked for a plus or minus 1 degree rotation about its center.
 - 4) Recommend 2x6 strongbacks, on edge, spaced at 10-0-0 oc and fastened to each truss with 3-10d (0.131" X 3") nails. Strongbacks to be attached to walls at their outer ends or restrained by other means.
 - 5) CAUTION, Do not erect truss backwards.

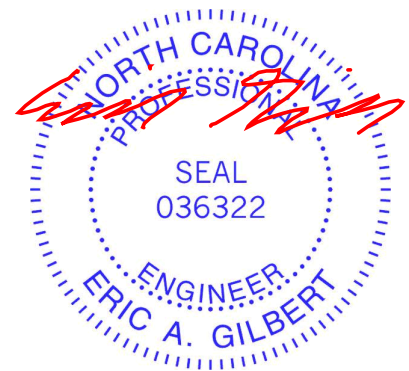

April 16, 2020

<p>WARNING - Verify design parameters and READ NOTES ON THIS AND INCLUDED MITEK REFERENCE PAGE MII-7473 rev. 5/19/2020 BEFORE USE.</p> <p>Design valid for use only with MiTek® connectors. This design is based only upon parameters shown, and is for an individual building component, not a truss system. Before use, the building designer must verify the applicability of design parameters and properly incorporate this design into the overall building design. Bracing indicated is to prevent buckling of individual truss web and/or chord members only. Additional temporary and permanent bracing is always required for stability and to prevent collapse with possible personal injury and property damage. For general guidance regarding the fabrication, storage, delivery, erection and bracing of trusses and truss systems, see ANSI/TPI1 Quality Criteria, DSB-89 and BCSI Building Component Safety Information available from Truss Plate Institute, 2670 Crain Highway, Suite 203 Waldorf, MD 20601</p>	<p>ENGINEERING BY TRENCO A MiTek Affiliate</p> <p>818 Soundside Road Edenton, NC 27932</p>
--	---

Job J1220-5672	Truss F2	Truss Type Floor	Qty 1	Ply 1	Lot 31 Forest Ridge	E14305212
-------------------	-------------	---------------------	----------	----------	---------------------	-----------

Comtech, Inc, Fayetteville, NC - 28314,

8.330 s Mar 23 2020 MiTek Industries, Inc. Thu Apr 16 14:03:11 2020 Page 1

ID:J6aSr?qB6etazEy6hKRSkZzPTZ_-R?4GX1O9cQ_PkO9y8M6WnFiv2ZjZE7_bKhIMDozQ76E

Job Reference (optional)

1-3-0

2-3-0

2-3-0

0-1-8

Scale = 1:49.8

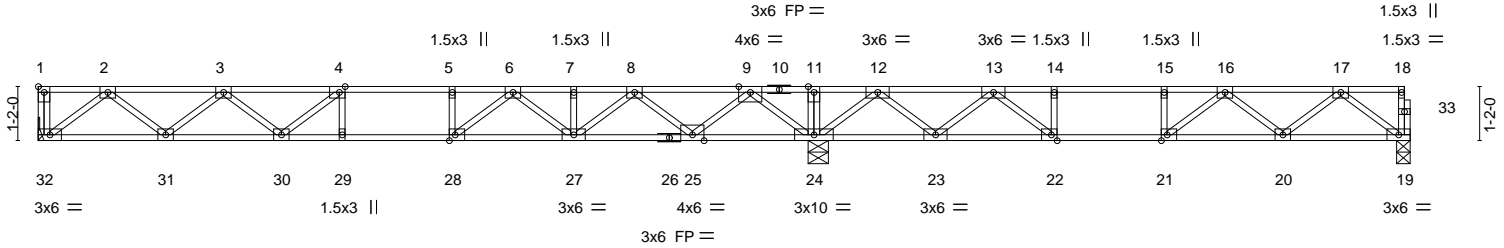

Plate Offsets (X,Y)--		[1:Edge,0-1-8], [4:0-1-8,Edge], [21:0-1-8,Edge], [22:0-1-8,Edge], [28:0-1-8,Edge]	
LOADING (psf)	SPACING-	CSI.	DEFL.
TCLL 40.0	Plate Grip DOL 1.00	TC 0.87	in (loc) l/defl L/d
TCDL 10.0	Lumber DOL 1.00	BC 0.85	Vert(LL) -0.18 28-29 >999 480
BCLL 0.0	Rep Stress Incr YES	WB 0.57	Vert(CT) -0.25 28-29 >810 360
BCDL 5.0	Code IRC2015/TPI2014	Matrix-S	Horz(CT) 0.05 19 n/a n/a
		Weight: 146 lb FT = 20%F, 11%E	

LUMBER-
 TOP CHORD 2x4 SP No.1(flat)
 BOT CHORD 2x4 SP No.1(flat)
 WEBS 2x4 SP No.3(flat)

BRACING-
 TOP CHORD Structural wood sheathing directly applied or 6-0-0 oc purlins, except end verticals.
 BOT CHORD Rigid ceiling directly applied or 6-0-0 oc bracing.

REACTIONS. (size) 32=Mechanical, 19=0-3-8, 24=0-5-4
 Max Grav 32=814(LC 3), 19=615(LC 4), 24=1907(LC 1)

FORCES. (lb) - Max. Comp./Max. Ten. - All forces 250 (lb) or less except when shown.
TOP CHORD 2-3=-1658/0, 3-4=-2582/0, 4-5=-2848/0, 5-6=-2848/0, 6-7=-2034/0, 7-8=-2034/0, 8-9=-563/296, 9-11=0/2082, 11-12=0/2082, 12-13=-578/905, 13-14=-1611/221, 14-15=-1611/221, 15-16=-1611/221, 16-17=-1179/0
BOT CHORD 31-32=0/1002, 30-31=0/2282, 29-30=0/2848, 28-29=0/2848, 27-28=0/2500, 25-27=-36/1414, 24-25=-810/0, 23-24=-1188/0, 22-23=-602/1165, 21-22=-221/1611, 20-21=0/1540, 19-20=0/756
WEBS 2-32=-1257/0, 2-31=0/854, 3-31=-813/0, 3-30=0/392, 4-30=-431/27, 9-24=-1619/0, 9-25=0/1194, 8-25=-1155/0, 8-27=0/843, 6-27=-652/0, 6-28=0/750, 5-28=-323/0, 17-19=-946/0, 17-20=0/550, 16-20=-470/84, 16-21=-317/90, 12-24=-1316/0, 12-23=0/876, 13-23=-920/0, 13-22=0/936, 14-22=-417/0

- NOTES-**
- Unbalanced floor live loads have been considered for this design.
 - All plates are 3x4 MT20 unless otherwise indicated.
 - Plates checked for a plus or minus 1 degree rotation about its center.
 - Refer to girder(s) for truss to truss connections.
 - Recommend 2x6 strongbacks, on edge, spaced at 10-0-0 oc and fastened to each truss with 3-10d (0.131" X 3") nails. Strongbacks to be attached to walls at their outer ends or restrained by other means.
 - CAUTION, Do not erect truss backwards.

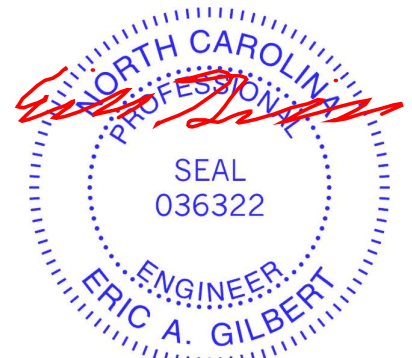

April 16, 2020

WARNING - Verify design parameters and READ NOTES ON THIS AND INCLUDED MITEK REFERENCE PAGE MII-7473 rev. 5/19/2020 BEFORE USE.

Design valid for use only with MiTek® connectors. This design is based only upon parameters shown, and is for an individual building component, not a truss system. Before use, the building designer must verify the applicability of design parameters and properly incorporate this design into the overall building design. Bracing indicated is to prevent buckling of individual truss web and/or chord members only. Additional temporary and permanent bracing is always required for stability and to prevent collapse with possible personal injury and property damage. For general guidance regarding the fabrication, storage, delivery, erection and bracing of trusses and truss systems, see

ANSI/TPI1 Quality Criteria, DSB-89 and BCSI Building Component

Safety Information available from Truss Plate Institute, 2670 Crain Highway, Suite 203 Waldorf, MD 20601



818 Soundside Road
 Edenton, NC 27932

Job J1220-5672	Truss F2A	Truss Type Floor	Qty 1	Ply 1	Lot 31 Forest Ridge	E14305213
-------------------	--------------	---------------------	----------	----------	---------------------	-----------

Comtech, Inc, Fayetteville, NC - 28314,

8.330 s Mar 23 2020 MiTek Industries, Inc. Thu Apr 16 14:03:15 2020 Page 1

ID:J6aSr?qB6etazEy6hKRskZzPTZ_-KmKmNPRgffUqD?TjNCBSx5tEDABIAv4BEIGaMZzQ76A

Job Reference (optional)

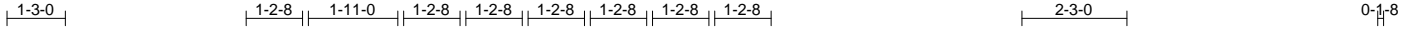

Scale = 1:49.4

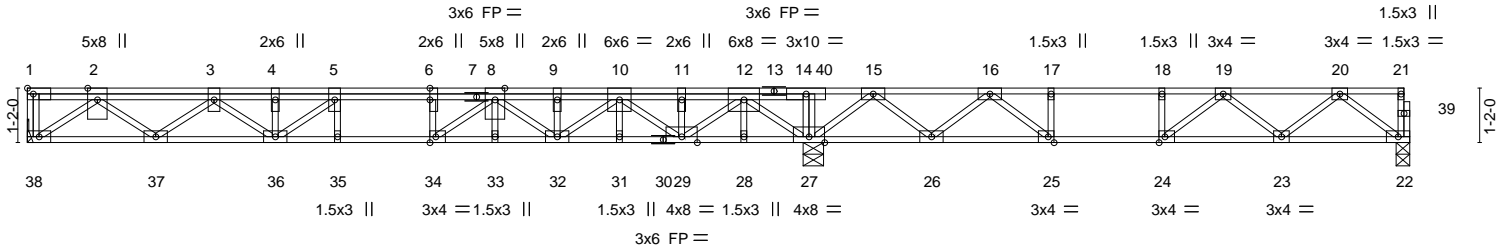

Plate Offsets (X, Y)--	[6:0-3-0,Edge], [24:0-1-8,Edge], [25:0-1-8,Edge], [34:0-1-8,Edge]
------------------------	---

LOADING (psf)	SPACING-	CSI.	DEFL.	in (loc)	l/defl	L/d	PLATES	GRIP
TCLL 40.0	Plate Grip DOL 1.00	TC 0.66	Vert(LL) -0.15	34	>999	480	MT20	244/190
TCDL 10.0	Lumber DOL 1.00	BC 0.48	Vert(CT) -0.20	34-35	>993	360		
BCLL 0.0	Rep Stress Incr NO	WB 0.69	Horz(CT) 0.04	22	n/a	n/a		
BCDL 5.0	Code IRC2015/TP12014	Matrix-S						

Weight: 175 lb FT = 20%F, 11%E

LUMBER-

TOP CHORD 2x4 SP 2400F 2.0E(flat)
 BOT CHORD 2x4 SP 2400F 2.0E(flat)
 WEBS 2x4 SP No.3(flat)

BRACING-

TOP CHORD Structural wood sheathing directly applied or 6-0-0 oc purlins, except end verticals.
 BOT CHORD Rigid ceiling directly applied or 6-0-0 oc bracing.

REACTIONS.

(size) 38=Mechanical, 27=0-5-4, 22=0-3-8
 Max Grav 38=951(LC 3), 27=2436(LC 1), 22=579(LC 4)

FORCES. (lb) - Max. Comp./Max. Ten. - All forces 250 (lb) or less except when shown.

TOP CHORD 2-3=-2097/0, 3-4=-3319/0, 4-5=-3319/0, 5-6=-3521/0, 6-8=-3521/0, 8-9=-2750/0, 9-10=-2750/0, 10-11=-1201/0, 11-12=-1201/0, 12-14=0/2484, 14-15=0/2500, 15-16=-224/1085, 16-17=-1394/330, 17-18=-1394/330, 18-19=-1394/330, 19-20=-1095/0
 BOT CHORD 37-38=0/1249, 36-37=0/2909, 35-36=0/3521, 34-35=0/3521, 33-34=0/3180, 32-33=0/3180, 31-32=0/2041, 29-31=0/2041, 28-29=-501/77, 27-28=-501/77, 26-27=-1403/0, 25-26=-753/865, 24-25=-330/1394, 23-24=-59/1406, 22-23=0/710
 WEBS 2-38=-1534/0, 2-37=0/1077, 3-37=-1031/0, 3-36=0/512, 4-36=-257/13, 12-27=-2425/0, 12-29=0/1449, 10-29=-1115/0, 10-32=0/936, 8-32=-593/0, 8-34=0/799, 6-34=-397/0, 15-27=-1479/0, 5-36=-372/209, 15-26=0/905, 16-26=-970/0, 16-25=0/989, 17-25=-436/0, 20-22=-888/0, 20-23=-6/501, 19-23=-405/117, 19-24=-370/0

NOTES-

- Unbalanced floor live loads have been considered for this design.
- All plates are 3x6 MT20 unless otherwise indicated.
- Plates checked for a plus or minus 1 degree rotation about its center.
- Refer to girder(s) for truss to truss connections.
- Recommend 2x6 strongbacks, on edge, spaced at 10-0-0 oc and fastened to each truss with 3-10d (0.131" X 3") nails. Strongbacks to be attached to walls at their outer ends or restrained by other means.
- CAUTION, Do not erect truss backwards.
- Hanger(s) or other connection device(s) shall be provided sufficient to support concentrated load(s) 222 lb down at 4-1-4, and 576 lb down at 15-1-12 on top chord. The design/selection of such connection device(s) is the responsibility of others.
- In the LOAD CASE(S) section, loads applied to the face of the truss are noted as front (F) or back (B).

LOAD CASE(S) Standard

- Dead + Floor Live (balanced): Lumber Increase=1.00, Plate Increase=1.00
 Uniform Loads (plf)
 Vert: 22-38=-10, 1-21=-100
 Concentrated Loads (lb)
 Vert: 3=-142(F) 12=-496(F)

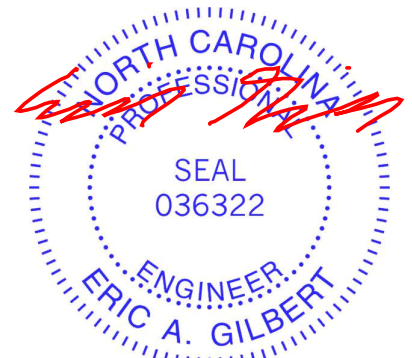

April 16, 2020

WARNING - Verify design parameters and READ NOTES ON THIS AND INCLUDED MITEK REFERENCE PAGE MII-7473 rev. 5/19/2020 BEFORE USE.

Design valid for use only with MiTek® connectors. This design is based only upon parameters shown, and is for an individual building component, not a truss system. Before use, the building designer must verify the applicability of design parameters and properly incorporate this design into the overall building design. Bracing indicated is to prevent buckling of individual truss web and/or chord members only. Additional temporary and permanent bracing is always required for stability and to prevent collapse with possible personal injury and property damage. For general guidance regarding the fabrication, storage, delivery, erection and bracing of trusses and truss systems, see **ANSI/TP1 Quality Criteria, DSB-89 and BCSI Building Component Safety Information** available from Truss Plate Institute, 2670 Crain Highway, Suite 203 Waldorf, MD 20601



818 Soundside Road
 Edenton, NC 27932

Job J1220-5672	Truss F3	Truss Type Floor	Qty 1	Ply 1	Lot 31 Forest Ridge Job Reference (optional)	E14305214
-------------------	-------------	---------------------	----------	----------	---	-----------

Comtech, Inc, Fayetteville, NC - 28314,

8.330 s Mar 23 2020 MiTek Industries, Inc. Thu Apr 16 14:03:18 2020 Page 1
ID:J6aSr?qB6etazEy6hKRSkZzPTZ_-kL?v?RTYasP4SBI2Kk9ZkVIVN6uNLfdxGUEzuzQ767

1-3-0

2-4-0

0-1-8

Scale: 1/2"=1'

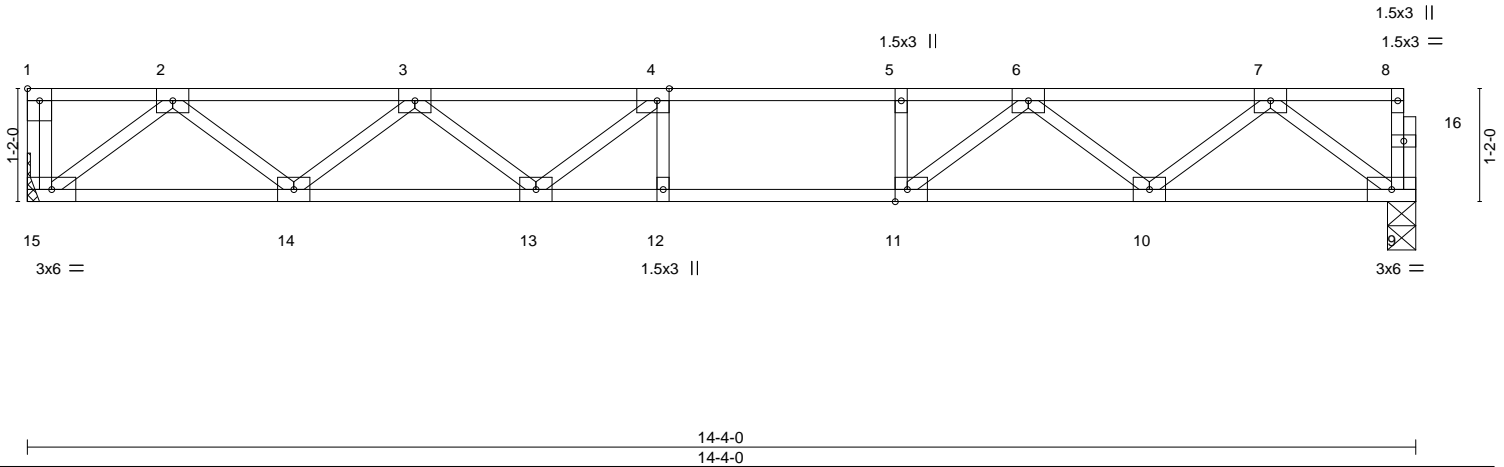

Plate Offsets (X,Y)--		[1:Edge,0-1-8], [4:0-1-8,Edge], [11:0-1-8,Edge]	
LOADING (psf)	SPACING-	2-0-0	CSL.
TCLL 40.0	Plate Grip DOL 1.00	TC 0.60	DEFL. in (loc) l/defl L/d
TCDL 10.0	Lumber DOL 1.00	BC 0.87	Vert(LL) -0.19 12-13 >906 480
BCLL 0.0	Rep Stress Incr YES	WB 0.38	Vert(CT) -0.25 12-13 >687 360
BCDL 5.0	Code IRC2015/TPI2014	Matrix-S	Horz(CT) 0.04 9 n/a n/a
			PLATES GRIP
			MT20 244/190
			Weight: 71 lb FT = 20%F, 11%E

LUMBER-
TOP CHORD 2x4 SP No.1(flat)
BOT CHORD 2x4 SP No.1(flat)
WEBS 2x4 SP No.3(flat)

BRACING-
TOP CHORD Structural wood sheathing directly applied or 6-0-0 oc purlins, except end verticals.
BOT CHORD Rigid ceiling directly applied or 10-0-0 oc bracing.

REACTIONS. (size) 15=Mechanical, 9=0-3-8
Max Grav 15=775(LC 1), 9=768(LC 1)

FORCES. (lb) - Max. Comp./Max. Ten. - All forces 250 (lb) or less except when shown.
TOP CHORD 2-3=-1559/0, 3-4=-2384/0, 4-5=-2550/0, 5-6=-2550/0, 6-7=-1538/0
BOT CHORD 14-15=0/947, 13-14=0/2143, 12-13=0/2550, 11-12=0/2550, 10-11=0/2118, 9-10=0/954
WEBS 2-15=-1188/0, 2-14=0/797, 3-14=-761/0, 3-13=0/398, 7-9=-1194/0, 7-10=0/760,
6-10=-755/0, 6-11=0/740, 5-11=-317/0, 4-13=-437/18

- NOTES-**
- 1) Unbalanced floor live loads have been considered for this design.
 - 2) All plates are 3x4 MT20 unless otherwise indicated.
 - 3) Plates checked for a plus or minus 1 degree rotation about its center.
 - 4) Refer to girder(s) for truss to truss connections.
 - 5) Recommend 2x6 strongbacks, on edge, spaced at 10-0-0 oc and fastened to each truss with 3-10d (0.131" X 3") nails. Strongbacks to be attached to walls at their outer ends or restrained by other means.
 - 6) CAUTION, Do not erect truss backwards.

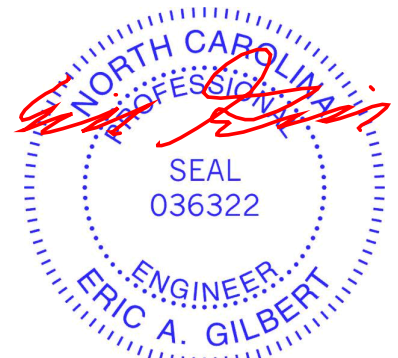

April 16, 2020

WARNING - Verify design parameters and READ NOTES ON THIS AND INCLUDED MITEK REFERENCE PAGE MII-7473 rev. 5/19/2020 BEFORE USE.

Design valid for use only with MiTek® connectors. This design is based only upon parameters shown, and is for an individual building component, not a truss system. Before use, the building designer must verify the applicability of design parameters and properly incorporate this design into the overall building design. Bracing indicated is to prevent buckling of individual truss web and/or chord members only. Additional temporary and permanent bracing is always required for stability and to prevent collapse with possible personal injury and property damage. For general guidance regarding the fabrication, storage, delivery, erection and bracing of trusses and truss systems, see

Safety Information available from Truss Plate Institute, 2670 Crain Highway, Suite 203 Waldorf, MD 20601
ANSI/TPI1 Quality Criteria, DSB-89 and BCSI Building Component

ENGINEERING BY
TRENCO
A MiTek Affiliate

818 Soundside Road
Edenton, NC 27932

Job J1220-5672	Truss F4	Truss Type Floor	Qty 4	Ply 1	Lot 31 Forest Ridge	E14305215
-------------------	-------------	---------------------	----------	----------	---------------------	-----------

Comtech, Inc, Fayetteville, NC - 28314,

8.330 s Mar 23 2020 MiTek Industries, Inc. Thu Apr 16 14:03:20 2020 Page 1
ID:J6aSr?qB6etazEy6hKRSkZzPTZ_-gj7fQ6UoUB67JmLgAlnde9a12BodrChwOazL1nzQ765



Scale = 1:41.8

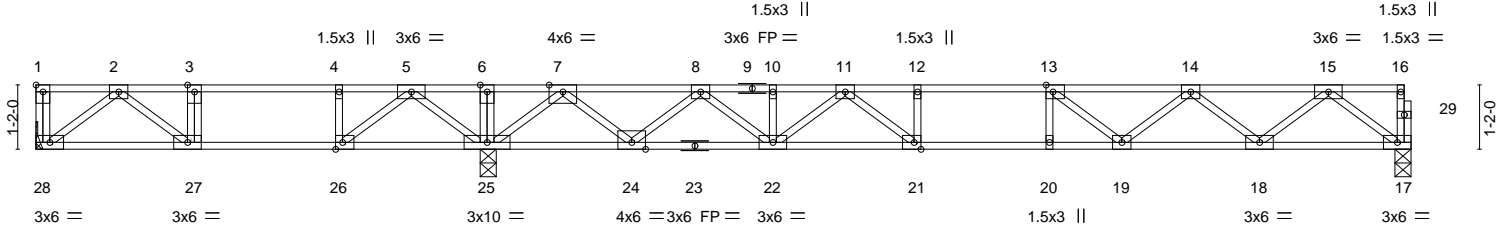

Plate Offsets (X,Y)--	[1:Edge,0-1-8], [13:0-1-8,Edge], [21:0-1-8,Edge], [26:0-1-8,Edge]
-----------------------	---

LOADING (psf)	SPACING- 2-0-0	CSI.	DEFL. in (loc) l/defl L/d	PLATES	GRIP
TCLL 40.0	Plate Grip DOL 1.00	TC 0.85	Vert(LL) -0.21 21-22 >964 480	MT20	244/190
TCDL 10.0	Lumber DOL 1.00	BC 0.86	Vert(CT) -0.28 21-22 >719 360		
BCLL 0.0	Rep Stress Incr NO	WB 0.54	Horz(CT) 0.05 17 n/a n/a		
BCDL 5.0	Code IRC2015/TPI2014	Matrix-S			
				Weight: 125 lb	FT = 20%F, 11%E

LUMBER-	BRACING-
TOP CHORD 2x4 SP No.1(flat)	TOP CHORD Structural wood sheathing directly applied or 6-0-0 oc purlins, except end verticals.
BOT CHORD 2x4 SP No.1(flat)	BOT CHORD Rigid ceiling directly applied or 6-0-0 oc bracing.
WEBS 2x4 SP No.3(flat)	

REACTIONS. (size) 28=Mechanical, 25=0-3-8, 17=0-3-8
Max Grav 28=1746(LC 3), 25=1571(LC 1), 17=851(LC 7)

FORCES. (lb) - Max. Comp./Max. Ten. - All forces 250 (lb) or less except when shown.
TOP CHORD 1-28=-1403/0, 2-3=-629/297, 3-4=-629/297, 4-5=-629/297, 5-6=0/1219, 6-7=0/1219, 7-8=-1123/0, 8-10=-2493/0, 10-11=-2493/0, 11-12=-3157/0, 12-13=-3157/0, 13-14=-2793/0, 14-15=-1763/0
BOT CHORD 27-28=-55/424, 26-27=-297/629, 25-26=-730/183, 24-25=-35/277, 22-24=0/1926, 21-22=0/2904, 20-21=0/3157, 19-20=0/3157, 18-19=0/2432, 17-18=0/1059
WEBS 2-28=-532/70, 2-27=-303/257, 5-25=-823/0, 5-26=0/878, 4-26=-429/0, 15-17=-1326/0, 15-18=0/917, 14-18=-871/0, 14-19=0/501, 7-25=-1524/0, 7-24=0/1128, 8-24=-1076/0, 8-22=0/753, 11-22=-559/0, 11-21=0/624, 12-21=-277/0, 13-19=-602/0

- NOTES-**
- 1) Unbalanced floor live loads have been considered for this design.
 - 2) All plates are 3x4 MT20 unless otherwise indicated.
 - 3) Plates checked for a plus or minus 1 degree rotation about its center.
 - 4) Refer to girder(s) for truss to truss connections.
 - 5) Recommend 2x6 strongbacks, on edge, spaced at 10-0-0 oc and fastened to each truss with 3-10d (0.131" X 3") nails. Strongbacks to be attached to walls at their outer ends or restrained by other means.
 - 6) CAUTION, Do not erect truss backwards.

LOAD CASE(S) Standard
 1) Dead + Floor Live (balanced): Lumber Increase=1.00, Plate Increase=1.00
 Uniform Loads (plf)
 Vert: 17-28=-10, 1-16=-100
 Concentrated Loads (lb)
 Vert: 1=-1350

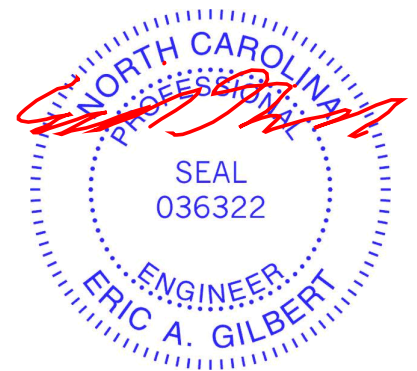

Job J1220-5672	Truss F4A	Truss Type Floor Girder	Qty 1	Ply 1	Lot 31 Forest Ridge	E14305216
-------------------	--------------	----------------------------	----------	----------	---------------------	-----------

Comtech, Inc, Fayetteville, NC - 28314,

8.330 s Mar 23 2020 MiTek Industries, Inc. Thu Apr 16 14:03:24 2020 Page 1
ID:J6aSr?qB6etazEy6hKRskZzPTZ_-ZVNAGUYJYQdYoNfSPbrZp?kk1oAEn_fWJCyYAYzQ761

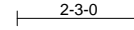
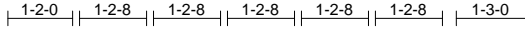

0-1-8

Scale = 1:41.5

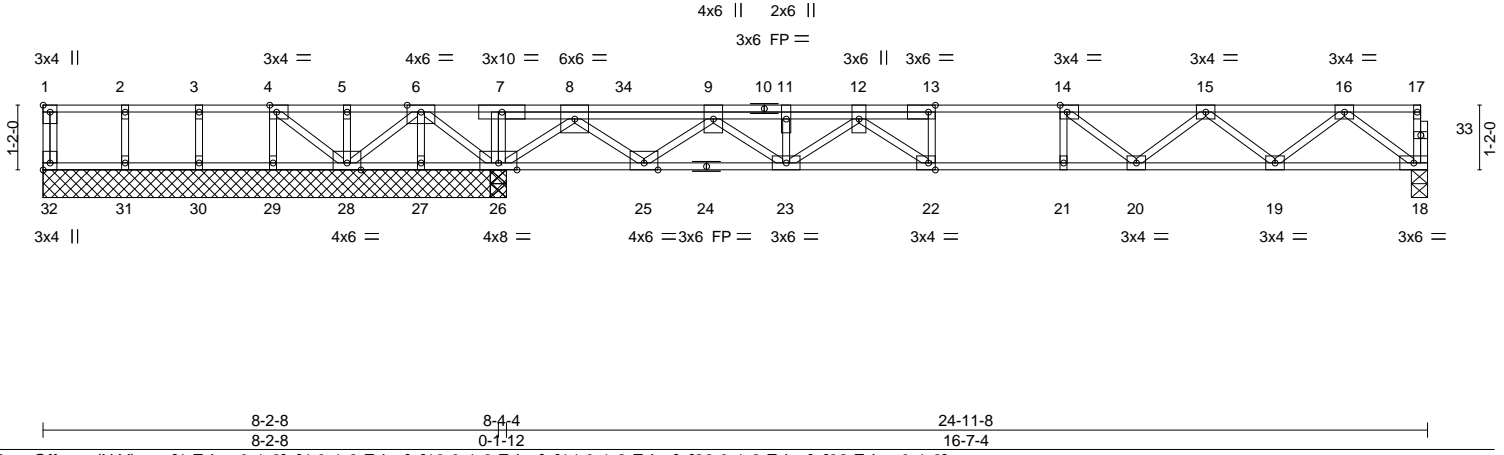

Plate Offsets (X,Y)--		[1:Edge,0-1-8], [4:0-1-8,Edge], [13:0-1-8,Edge], [14:0-1-8,Edge], [22:0-1-8,Edge], [32:Edge,0-1-8]							
LOADING (psf)	SPACING-	2-0-0	CSI.	DEFL.	in (loc)	l/defl	L/d	PLATES	GRIP
TCLL 40.0	Plate Grip DOL	1.00	TC 0.79	Vert(LL)	-0.17	20-21	>999	MT20	244/190
TCDL 10.0	Lumber DOL	1.00	BC 0.81	Vert(CT)	-0.23	21	>881		
BCLL 0.0	Rep Stress Incr	NO	WB 0.67	Horz(CT)	0.03	18	n/a		
BCDL 5.0	Code	IRC2015/TPI2014	Matrix-S						
								Weight: 136 lb	FT = 20%F, 11%E

LUMBER-
TOP CHORD 2x4 SP No.1(flat)
BOT CHORD 2x4 SP No.1(flat)
WEBS 2x4 SP No.3(flat)

BRACING-
TOP CHORD Structural wood sheathing directly applied or 6-0-0 oc purlins, except end verticals.
BOT CHORD Rigid ceiling directly applied or 10-0-0 oc bracing, Except: 6-0-0 oc bracing: 27-28,26-27,25-26.

REACTIONS. All bearings 8-4-4 except (jt=length) 18=0-3-8.
(lb) - Max Uplift All uplift 100 lb or less at joint(s) except 27=-448(LC 4), 28=-344(LC 4), 29=-254(LC 4)
Max Grav All reactions 250 lb or less at joint(s) 32, 28, 29, 30, 31 except 26=2622(LC 1), 26=2622(LC 1), 18=775(LC 4)

FORCES. (lb) - Max. Comp./Max. Ten. - All forces 250 (lb) or less except when shown.
TOP CHORD 4-5=0/391, 5-6=0/391, 6-7=0/2930, 7-8=0/2937, 9-11=-1767/0, 11-12=-1767/0, 12-13=-2619/0, 13-14=-2617/0, 14-15=-2418/0, 15-16=-1576/0
BOT CHORD 27-28=-1260/0, 26-27=-1260/0, 25-26=-1151/0, 23-25=0/1119, 22-23=0/2282, 21-22=0/2617, 20-21=0/2617, 19-20=0/2166, 18-19=0/956
WEBS 6-26=-2091/0, 6-27=0/434, 6-28=0/1122, 4-28=-496/0, 4-29=0/265, 8-26=-2311/0, 8-25=0/1401, 9-25=-1369/0, 9-23=0/808, 16-18=-1196/0, 16-19=0/807, 15-19=-768/0, 15-20=0/383, 14-20=-417/0, 12-23=-643/0, 12-22=0/580

- NOTES-**
- Unbalanced floor live loads have been considered for this design.
 - All plates are 1.5x3 MT20 unless otherwise indicated.
 - Plates checked for a plus or minus 1 degree rotation about its center.
 - Provide mechanical connection (by others) of truss to bearing plate capable of withstanding 448 lb uplift at joint 27, 344 lb uplift at joint 28 and 254 lb uplift at joint 29.
 - Recommend 2x6 strongbacks, on edge, spaced at 10-0-0 oc and fastened to each truss with 3-10d (0.131" X 3") nails. Strongbacks to be attached to walls at their outer ends or restrained by other means.
 - CAUTION, Do not erect truss backwards.
 - Hanger(s) or other connection device(s) shall be provided sufficient to support concentrated load(s) 407 lb down at 10-5-12 on top chord. The design/selection of such connection device(s) is the responsibility of others.
 - In the LOAD CASE(S) section, loads applied to the face of the truss are noted as front (F) or back (B).

LOAD CASE(S) Standard
1) Dead + Floor Live (balanced): Lumber Increase=1.00, Plate Increase=1.00
Uniform Loads (plf)
Vert: 18-32=-10, 1-17=-100
Concentrated Loads (lb)
Vert: 34=-327(B)

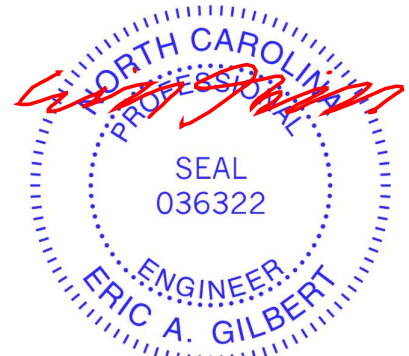

April 16, 2020

WARNING - Verify design parameters and READ NOTES ON THIS AND INCLUDED MITEK REFERENCE PAGE MII-7473 rev. 5/19/2020 BEFORE USE.

Design valid for use only with MiTek® connectors. This design is based only upon parameters shown, and is for an individual building component, not a truss system. Before use, the building designer must verify the applicability of design parameters and properly incorporate this design into the overall building design. Bracing indicated is to prevent buckling of individual truss web and/or chord members only. Additional temporary and permanent bracing is always required for stability and to prevent collapse with possible personal injury and property damage. For general guidance regarding the fabrication, storage, delivery, erection and bracing of trusses and truss systems, see

ANSI/TPI1 Quality Criteria, DSB-89 and BCSI Building Component

Safety Information available from Truss Plate Institute, 2670 Crain Highway, Suite 203 Waldorf, MD 20601



818 Soundside Road
Edenton, NC 27932

Job J1220-5672	Truss F5	Truss Type Floor	Qty 6	Ply 1	Lot 31 Forest Ridge	E14305217
-------------------	-------------	---------------------	----------	----------	---------------------	-----------

Comtech, Inc, Fayetteville, NC - 28314,

8.330 s Mar 23 2020 MITek Industries, Inc. Thu Apr 16 14:03:27 2020 Page 1
ID:J6aSr?qB6etazEy6hKRSkZzPTZ_-z42JuVaBrl?7frN04jPGRdMG0?CU_MQy?AACntzQ76_



Scale = 1:41.8

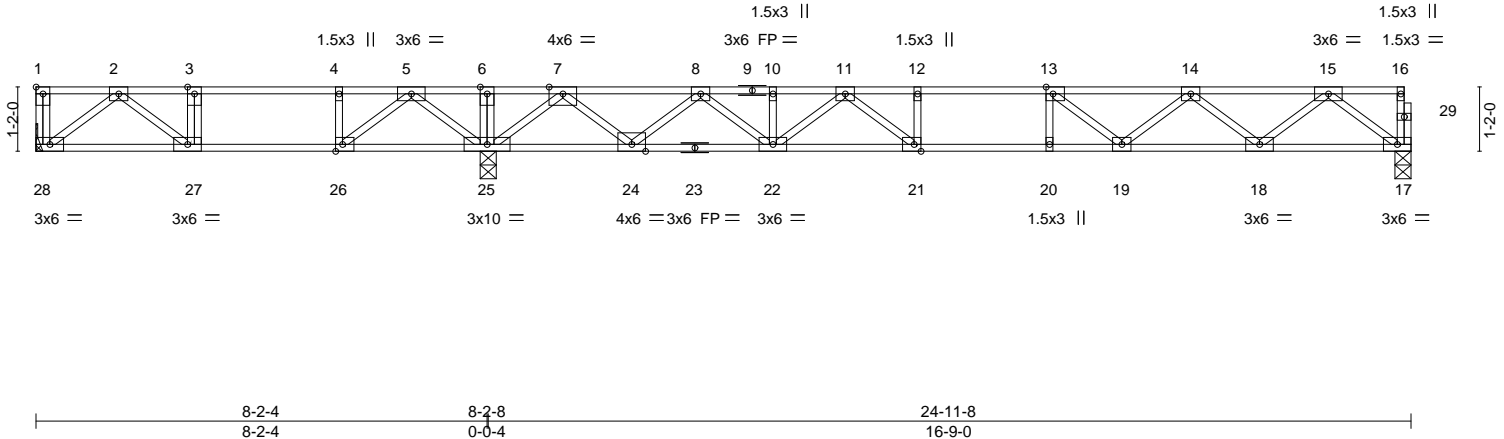

Plate Offsets (X,Y)--	[1:Edge,0-1-8], [13:0-1-8,Edge], [21:0-1-8,Edge], [26:0-1-8,Edge]
-----------------------	---

LOADING (psf)	SPACING-	2-0-0	CSI.	DEFL.	in (loc)	l/defl	L/d	PLATES	GRIP	
TCLL 40.0	Plate Grip DOL	1.00	TC 0.74	Vert(LL)	-0.21	21-22	>964	480	MT20	244/190
TCDL 10.0	Lumber DOL	1.00	BC 0.78	Vert(CT)	-0.28	21-22	>719	360		
BCLL 0.0	Rep Stress Incr	YES	WB 0.54	Horz(CT)	0.05	17	n/a	n/a		
BCDL 5.0	Code	IRC2015/TPI2014	Matrix-S							
									Weight: 125 lb	FT = 20%F, 11%E

LUMBER-	BRACING-
TOP CHORD 2x4 SP No.1(flat)	TOP CHORD Structural wood sheathing directly applied or 6-0-0 oc purlins, except end verticals.
BOT CHORD 2x4 SP No.1(flat)	BOT CHORD Rigid ceiling directly applied or 6-0-0 oc bracing.
WEBS 2x4 SP No.3(flat)	

REACTIONS. (size) 28=Mechanical, 25=0-3-8, 17=0-3-8
 Max Uplift 28=14(LC 4)
 Max Grav 28=396(LC 3), 25=1571(LC 1), 17=851(LC 7)

FORCES. (lb) - Max. Comp./Max. Ten. - All forces 250 (lb) or less except when shown.
 TOP CHORD 2-3=-629/297, 3-4=-629/297, 4-5=-629/297, 5-6=0/1219, 6-7=0/1219, 7-8=-1123/0, 8-10=-2493/0, 10-11=-2493/0, 11-12=-3157/0, 12-13=-3157/0, 13-14=-2793/0, 14-15=-1763/0
 BOT CHORD 27-28=-56/423, 26-27=-297/629, 25-26=-730/184, 24-25=-34/277, 22-24=0/1927, 21-22=0/2904, 20-21=0/3157, 19-20=0/3157, 18-19=0/2432, 17-18=0/1059
 WEBS 2-28=-531/70, 2-27=-302/259, 5-25=-823/0, 5-26=0/878, 4-26=-429/0, 15-17=-1326/0, 15-18=0/917, 14-18=-871/0, 14-19=0/501, 7-25=-1524/0, 7-24=0/1128, 8-24=-1076/0, 8-22=0/753, 11-22=-559/0, 11-21=0/624, 12-21=-277/0, 13-19=-603/0

- NOTES-**
- 1) Unbalanced floor live loads have been considered for this design.
 - 2) All plates are 3x4 MT20 unless otherwise indicated.
 - 3) Plates checked for a plus or minus 1 degree rotation about its center.
 - 4) Refer to girder(s) for truss to truss connections.
 - 5) Provide mechanical connection (by others) of truss to bearing plate capable of withstanding 14 lb uplift at joint 28.
 - 6) Recommend 2x6 strongbacks, on edge, spaced at 10-0-0 oc and fastened to each truss with 3-10d (0.131" X 3") nails. Strongbacks to be attached to walls at their outer ends or restrained by other means.
 - 7) CAUTION, Do not erect truss backwards.

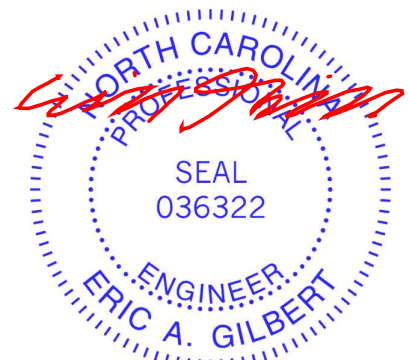

April 16, 2020

WARNING - Verify design parameters and READ NOTES ON THIS AND INCLUDED MITEK REFERENCE PAGE MII-7473 rev. 5/19/2020 BEFORE USE.
 Design valid for use only with MITek® connectors. This design is based only upon parameters shown, and is for an individual building component, not a truss system. Before use, the building designer must verify the applicability of design parameters and properly incorporate this design into the overall building design. Bracing indicated is to prevent buckling of individual truss web and/or chord members only. Additional temporary and permanent bracing is always required for stability and to prevent collapse with possible personal injury and property damage. For general guidance regarding the fabrication, storage, delivery, erection and bracing of trusses and truss systems, see **ANSI/TPI1 Quality Criteria, DSB-89 and BCSI Building Component Safety Information** available from Truss Plate Institute, 2670 Crain Highway, Suite 203 Waldorf, MD 20601

ENGINEERING BY
TRENCO
 A MITek Affiliate
 818 Soundside Road
 Edenton, NC 27932

Job J1220-5672	Truss F6	Truss Type Floor	Qty 2	Ply 1	Lot 31 Forest Ridge	E14305218
-------------------	-------------	---------------------	----------	----------	---------------------	-----------

Comtech, Inc, Fayetteville, NC - 28314,

8.330 s Mar 23 2020 MiTek Industries, Inc. Thu Apr 16 14:03:30 2020 Page 1
ID:J6aSr?qB6etazEy6hKRSkZzPTZ_-OfkRWXc47GNiWl6lryz2G_skDL3Bo4Oh8PINBzQ75x

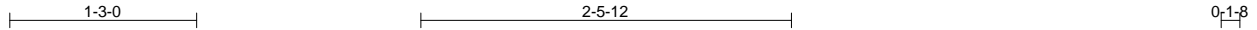

Scale = 1:15.4

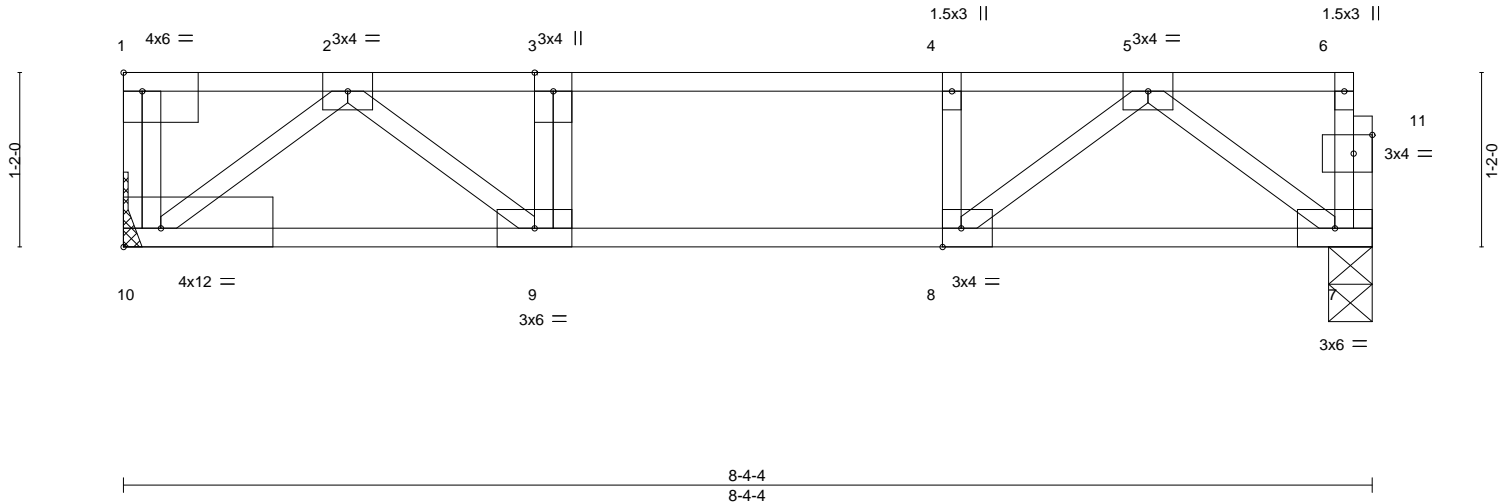

Plate Offsets (X,Y)-- [1:Edge,0-1-8], [8:0-1-8,Edge], [10:Edge,0-1-8], [11:0-1-8,0-1-8]

LOADING (psf)	SPACING-	2-0-0	CSI.	DEFL.	in (loc)	l/defl	L/d	PLATES	GRIP
TCLL 40.0	Plate Grip DOL	1.00	TC 0.39	Vert(LL)	-0.04	9-10	>999	MT20	244/190
TCDL 10.0	Lumber DOL	1.00	BC 0.27	Vert(CT)	-0.05	9-10	>999		
BCLL 0.0	Rep Stress Incr	NO	WB 0.22	Horz(CT)	0.01	7	n/a		
BCDL 5.0	Code	IRC2015/TPI2014	Matrix-S						
								Weight: 43 lb	FT = 20%F, 11%E

LUMBER-	BRACING-
TOP CHORD 2x4 SP No.1(flat)	TOP CHORD Structural wood sheathing directly applied or 6-0-0 oc purlins, except end verticals.
BOT CHORD 2x4 SP No.1(flat)	BOT CHORD Rigid ceiling directly applied or 10-0-0 oc bracing.
WEBS 2x4 SP No.3(flat)	

REACTIONS. (size) 10=Mechanical, 7=0-3-8
Max Grav 10=3846(LC 1), 7=440(LC 1)

FORCES. (lb) - Max. Comp./Max. Ten. - All forces 250 (lb) or less except when shown.
TOP CHORD 1-10=-3459/0, 2-3=-821/0, 3-4=-821/0, 4-5=-821/0
BOT CHORD 9-10=0/493, 8-9=0/821, 7-8=0/489
WEBS 2-10=-619/0, 2-9=0/460, 5-7=-609/0, 5-8=0/469

- NOTES-**
- Unbalanced floor live loads have been considered for this design.
 - Plates checked for a plus or minus 1 degree rotation about its center.
 - Refer to girder(s) for truss to truss connections.
 - Recommend 2x6 strongbacks, on edge, spaced at 10-0-0 oc and fastened to each truss with 3-10d (0.131" X 3") nails. Strongbacks to be attached to walls at their outer ends or restrained by other means.
 - CAUTION, Do not erect truss backwards.

LOAD CASE(S) Standard
1) Dead + Floor Live (balanced): Lumber Increase=1.00, Plate Increase=1.00
Uniform Loads (plf)
Vert: 7-10=-10, 1-6=-100
Concentrated Loads (lb)
Vert: 1=-3400



April 16, 2020

Job J1220-5672	Truss F7	Truss Type Floor	Qty 1	Ply 1	Lot 31 Forest Ridge	E14305219
-------------------	-------------	---------------------	----------	----------	---------------------	-----------

Comtech, Inc, Fayetteville, NC - 28314,

8.330 s Mar 23 2020 MiTek Industries, Inc. Thu Apr 16 14:03:32 2020 Page 1
ID:J6aSr?qB6etazEy6hKRSkZzPTZ_-K1sCxDeKftdQlCg_tG_R7h4HJ05sflDh9SuzR4zQ75v

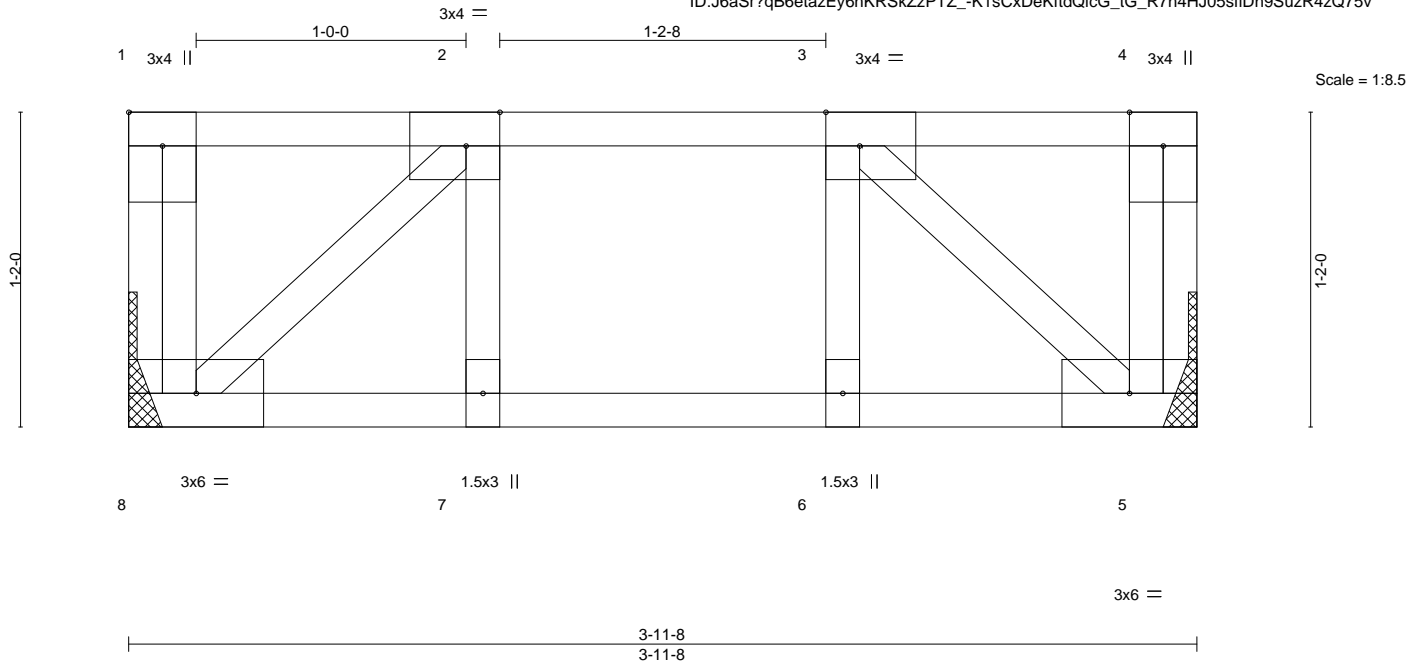

Plate Offsets (X,Y)--	[1:Edge,0-1-8], [2:0-1-8,Edge], [3:0-1-8,Edge]
LOADING (psf)	SPACING- 2-0-0
TCLL 40.0	Plate Grip DOL 1.00
TCDL 10.0	Lumber DOL 1.00
BCLL 0.0	Rep Stress Incr YES
BCDL 5.0	Code IRC2015/TPI2014
	CSI.
	TC 0.06
	BC 0.06
	WB 0.05
	Matrix-S
	DEFL. in (loc) l/defl L/d
	Vert(LL) -0.00 7 >999 480
	Vert(CT) -0.00 7 >999 360
	Horz(CT) 0.00 5 n/a n/a
	PLATES GRIP
	MT20 244/190
	Weight: 24 lb FT = 20%F, 11%E

LUMBER-
TOP CHORD 2x4 SP No.1(flat)
BOT CHORD 2x4 SP No.1(flat)
WEBS 2x4 SP No.3(flat)

BRACING-
TOP CHORD Structural wood sheathing directly applied or 3-11-8 oc purlins, except end verticals.
BOT CHORD Rigid ceiling directly applied or 10-0-0 oc bracing.

REACTIONS. (size) 8=Mechanical, 5=Mechanical
Max Grav 8=204(LC 1), 5=204(LC 1)

FORCES. (lb) - Max. Comp./Max. Ten. - All forces 250 (lb) or less except when shown.

- NOTES-**
- 1) Unbalanced floor live loads have been considered for this design.
 - 2) Plates checked for a plus or minus 1 degree rotation about its center.
 - 3) Refer to girder(s) for truss to truss connections.
 - 4) Recommend 2x6 strongbacks, on edge, spaced at 10-0-0 oc and fastened to each truss with 3-10d (0.131" X 3") nails. Strongbacks to be attached to walls at their outer ends or restrained by other means.

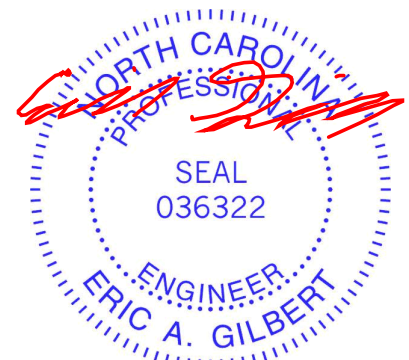

April 16, 2020

Job J1220-5672	Truss FG1	Truss Type Floor Girder	Qty 1	Ply 1	Lot 31 Forest Ridge	E14305220
-------------------	--------------	----------------------------	----------	----------	---------------------	-----------

Comtech, Inc, Fayetteville, NC - 28314,

8.330 s Mar 23 2020 MiTek Industries, Inc. Thu Apr 16 14:03:35 2020 Page 1

ID:J6aSr?qB6etazEy6hKRSkZzPTZ_-kcXKaFgDyo??c4?ZY0Y8lJioiE7ds5k7rQ6e2PzQ75s

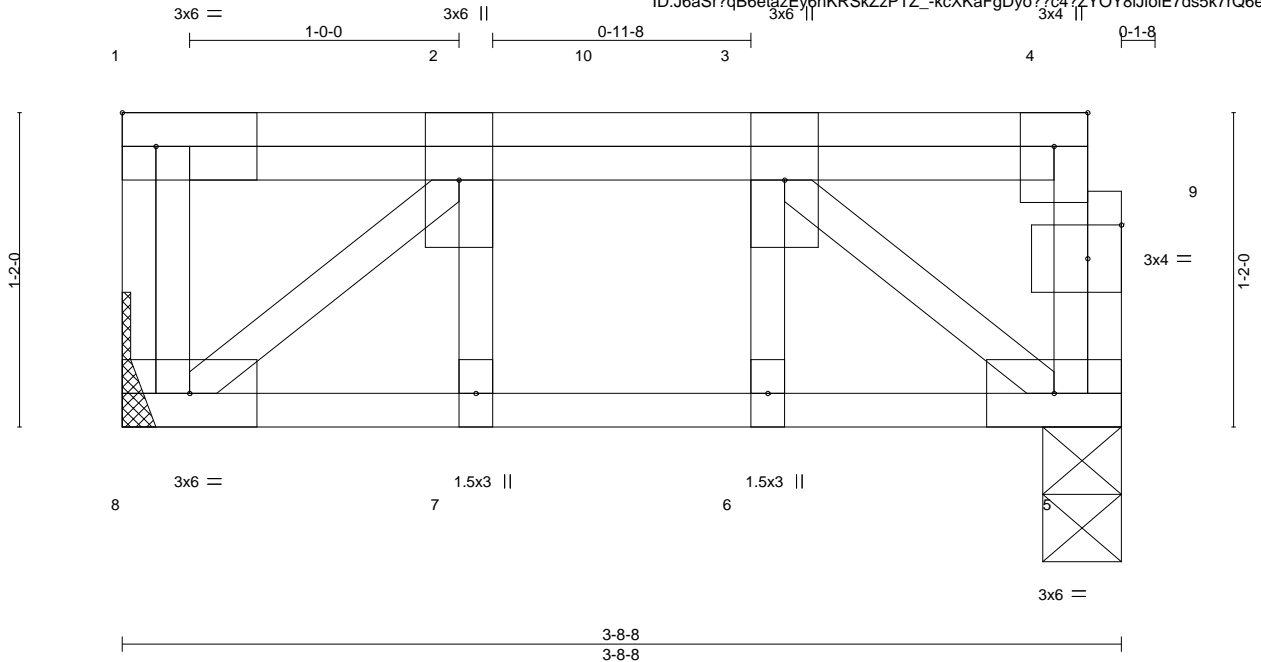

Plate Offsets (X,Y)--	[9:0-1-8,0-1-8]				
LOADING (psf)	SPACING- 2-0-0	CSI.	DEFL. in (loc) l/defl L/d	PLATES	GRIP
TCLL 40.0	Plate Grip DOL 1.00	TC 0.05	Vert(LL) -0.00 7 >999 480	MT20	244/190
TCDL 10.0	Lumber DOL 1.00	BC 0.06	Vert(CT) -0.00 7 >999 360		
BCLL 0.0	Rep Stress Incr NO	WB 0.07	Horz(CT) 0.00 5 n/a n/a		
BCDL 5.0	Code IRC2015/TPI2014	Matrix-S		Weight: 27 lb	FT = 20%F, 11%E

LUMBER-	BRACING-
TOP CHORD 2x4 SP No.1(flat)	TOP CHORD Structural wood sheathing directly applied or 3-8-8 oc purlins, except end verticals.
BOT CHORD 2x4 SP No.1(flat)	BOT CHORD Rigid ceiling directly applied or 10-0-0 oc bracing.
WEBS 2x4 SP No.3(flat)	

REACTIONS. (size) 8=Mechanical, 5=0-3-8
Max Grav 8=242(LC 1), 5=236(LC 1)

FORCES. (lb) - Max. Comp./Max. Ten. - All forces 250 (lb) or less except when shown.
WEBS 2-8=-294/0, 3-5=-291/0

- NOTES-**
- 1) Unbalanced floor live loads have been considered for this design.
 - 2) Plates checked for a plus or minus 1 degree rotation about its center.
 - 3) Refer to girder(s) for truss to truss connections.
 - 4) Recommend 2x6 strongbacks, on edge, spaced at 10-0-0 oc and fastened to each truss with 3-10d (0.131" X 3") nails. Strongbacks to be attached to walls at their outer ends or restrained by other means.
 - 5) CAUTION, Do not erect truss backwards.
 - 6) Hanger(s) or other connection device(s) shall be provided sufficient to support concentrated load(s) 122 lb down at 1-10-4 on top chord. The design/selection of such connection device(s) is the responsibility of others.
 - 7) In the LOAD CASE(S) section, loads applied to the face of the truss are noted as front (F) or back (B).

LOAD CASE(S) Standard
1) Dead + Floor Live (balanced): Lumber Increase=1.00, Plate Increase=1.00
Uniform Loads (plf)
Vert: 5-8=10, 1-4=-100
Concentrated Loads (lb)
Vert: 10=-104(F)



April 16, 2020

Job J1220-5672	Truss FG2	Truss Type Floor Girder	Qty 1	Ply 1	Lot 31 Forest Ridge	E14305221
-------------------	--------------	----------------------------	----------	----------	---------------------	-----------

Comtech, Inc, Fayetteville, NC - 28314,

8.330 s Mar 23 2020 MiTek Industries, Inc. Thu Apr 16 14:03:38 2020 Page 1

ID:J6aSr?QB6etazEy6hKRSkZzPTZ_-9BDTCGisFjNXTXj8DX5rNyKHLR5_3R3aXOLIfkzQ75p

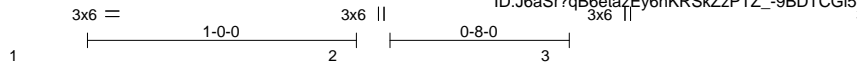

Scale = 1:8.6

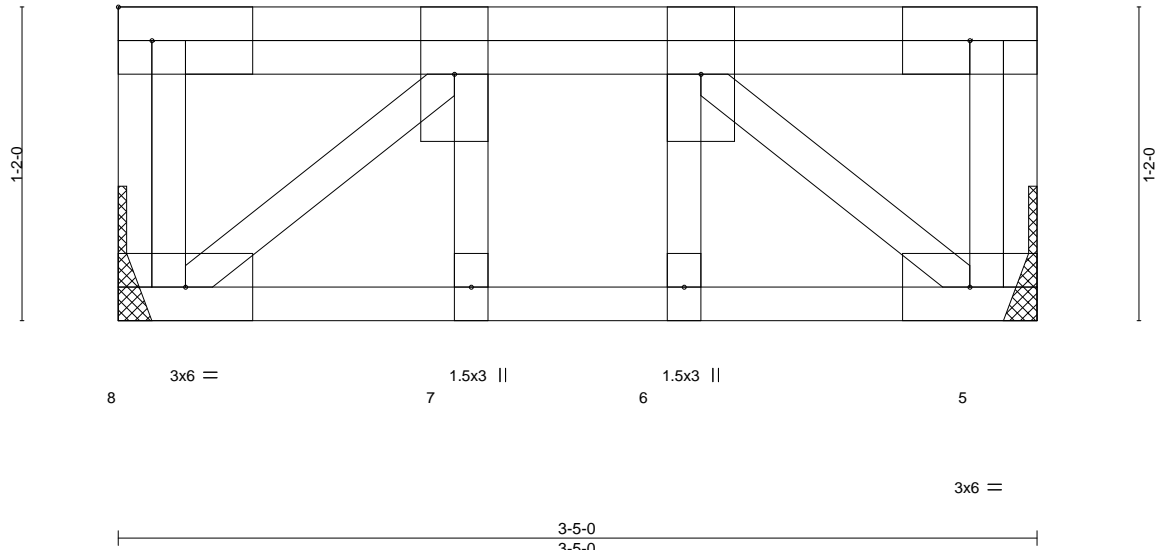

LOADING (psf)	SPACING-	CSI.	DEFL.	in (loc)	l/defl	L/d	PLATES	GRIP
TCLL 40.0	Plate Grip DOL 1.00	TC 0.16	Vert(LL) -0.01	7	>999	480	MT20	244/190
TCDL 10.0	Lumber DOL 1.00	BC 0.21	Vert(CT) -0.01	7	>999	360		
BCLL 0.0	Rep Stress Incr NO	WB 0.16	Horz(CT) 0.00	5	n/a	n/a		
BCDL 5.0	Code IRC2015/TPI2014	Matrix-S					Weight: 26 lb	FT = 20%F, 11%E

LUMBER-
 TOP CHORD 2x4 SP No.1(flat)
 BOT CHORD 2x4 SP No.1(flat)
 WEBS 2x4 SP No.3(flat)

BRACING-
 TOP CHORD Structural wood sheathing directly applied or 3-5-0 oc purlins, except end verticals.
 BOT CHORD Rigid ceiling directly applied or 10-0-0 oc bracing.

REACTIONS. (size) 8=Mechanical, 5=Mechanical
 Max Grav 8=596(LC 1), 5=427(LC 1)

FORCES. (lb) - Max. Comp./Max. Ten. - All forces 250 (lb) or less except when shown.
 TOP CHORD 2-3=-528/0
 BOT CHORD 7-8=0/528, 6-7=0/528, 5-6=0/528
 WEBS 2-8=-684/0, 3-5=-684/0

- NOTES-**
- 1) Unbalanced floor live loads have been considered for this design.
 - 2) Plates checked for a plus or minus 1 degree rotation about its center.
 - 3) Refer to girder(s) for truss to truss connections.
 - 4) Recommend 2x6 strongbacks, on edge, spaced at 10-0-0 oc and fastened to each truss with 3-10d (0.131" X 3") nails. Strongbacks to be attached to walls at their outer ends or restrained by other means.
 - 5) Hanger(s) or other connection device(s) shall be provided sufficient to support concentrated load(s) 705 lb down at 1-6-12 on top chord. The design/selection of such connection device(s) is the responsibility of others.
 - 6) In the LOAD CASE(S) section, loads applied to the face of the truss are noted as front (F) or back (B).

LOAD CASE(S) Standard
 1) Dead + Floor Live (balanced): Lumber Increase=1.00, Plate Increase=1.00
 Uniform Loads (plf)
 Vert: 5-8=-10, 1-4=-100
 Concentrated Loads (lb)
 Vert: 2=-675(B)

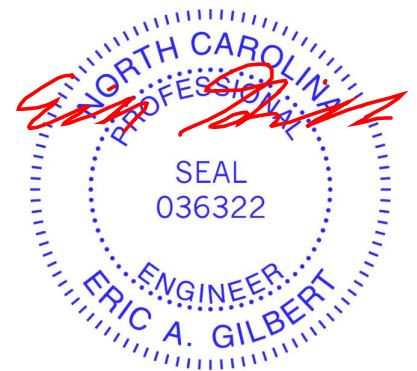

April 16, 2020

Symbols

PLATE LOCATION AND ORIENTATION

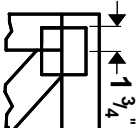

Center plate on joint unless x, y offsets are indicated. Dimensions are in ft-in-sixteenths. Apply plates to both sides of truss and fully embed teeth.

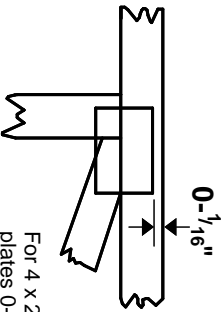

For 4 x 2 orientation, locate plates 0- 1/16" from outside edge of truss.



This symbol indicates the required direction of slots in connector plates.

* Plate location details available in **MITek 20/20 software** or upon request.

PLATE SIZE

4 X 4

The first dimension is the plate width measured perpendicular to slots. Second dimension is the length parallel to slots.

LATERAL BRACING LOCATION



Indicated by symbol shown and/or by text in the bracing section of the output. Use T or I bracing if indicated.

BEARING

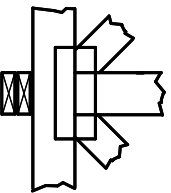

Indicates location where bearings (supports) occur. Icons vary but reaction section indicates joint number where bearings occur. Min size shown is for crushing only.

Industry Standards:

ANSI/TP1: National Design Specification for Metal Plate Connected Wood Truss Construction.
DSB-89: Design Standard for Bracing, Building Component Safety Information, Guide to Good Practice for Handling, Installing & Bracing of Metal Plate
BCSI: Connected Wood Trusses.

Numbering System

6-4-8
dimensions shown in ft-in-sixteenths
(Drawings not to scale)

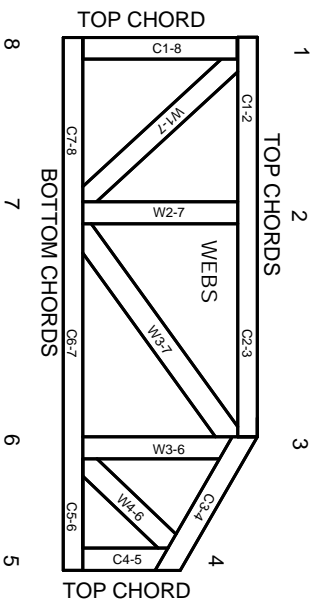

JOINTS ARE GENERALLY NUMBERED/LETTERED CLOCKWISE AROUND THE TRUSS STARTING AT THE JOINT FARTHEST TO THE LEFT.

CHORDS AND WEBS ARE IDENTIFIED BY END JOINT NUMBERS/LETTERS.

PRODUCT CODE APPROVALS

ICC-ES Reports:

ESR-1311, ESR-1352, ESR1988
ER-3907, ESR-2362, ESR-1397, ESR-3282

Trusses are designed for wind loads in the plane of the truss unless otherwise shown.

Lumber design values are in accordance with ANSI/TP1 section 6.3 These truss designs rely on lumber values established by others.

© 2012 MITteK® All Rights Reserved



MITek Engineering Reference Sheet: Mill-7473 rev. 5/19/2020



General Safety Notes

Failure to Follow Could Cause Property Damage or Personal Injury

1. Additional stability bracing for truss system, e.g. diagonal or X-bracing, is always required. See BCSI.
2. Truss bracing must be designed by an engineer. For wide truss spacing, individual lateral braces themselves may require bracing, or alternative Tor I bracing should be considered.
3. Never exceed the design loading shown and never stack materials on inadequately braced trusses.
4. Provide copies of this truss design to the building designer, erection supervisor, property owner and all other interested parties.
5. Cut members to bear tightly against each other.
6. Place plates on each face of truss at each joint and embed fully. Knots and wane at joint locations are regulated by ANSI/TP1 1.
7. Design assumes trusses will be suitably protected from the environment in accord with ANSI/TP1 1.
8. Unless otherwise noted, moisture content of lumber shall not exceed 19% at time of fabrication.
9. Unless expressly noted, this design is not applicable for use with fire retardant, preservative treated, or green lumber.
10. Camber is a non-structural consideration and is the responsibility of truss fabricator. General practice is to camber for dead load deflection.
11. Plate type, size, orientation and location dimensions indicated are minimum plating requirements.
12. Lumber used shall be of the species and size, and in all respects, equal to or better than that specified.
13. Top chords must be sheathed or purlins provided at spacing indicated on design.
14. Bottom chords require lateral bracing at 10 ft. spacing, or less, if no ceiling is installed, unless otherwise noted.
15. Connections not shown are the responsibility of others.
16. Do not cut or alter truss member or plate without prior approval of an engineer.
17. Install and load vertically unless indicated otherwise.
18. Use of green or treated lumber may pose unacceptable environmental, health or performance risks. Consult with project engineer before use.
19. Review all portions of this design (front, back, words and pictures) before use. Rewriting pictures alone is not sufficient.
20. Design assumes manufacture in accordance with ANSI/TP1 1 Quality Criteria.
21. The design does not take into account any dynamic or other loads other than those expressly stated.