



Front Elevation
Scale: 1/4" = 1'0"

6" PVC COLUMNS

NOTICE TO CONTRACTOR
All construction must comply with current NC Building Codes and be subject to local inspections and setbacks.
APPROVED
Limited building only review.
Permit holder responsible for full compliance with the code.
06/29/2021
Harnett COUNTY NORTH CAROLINA

Revised floor layout 10/29/2020

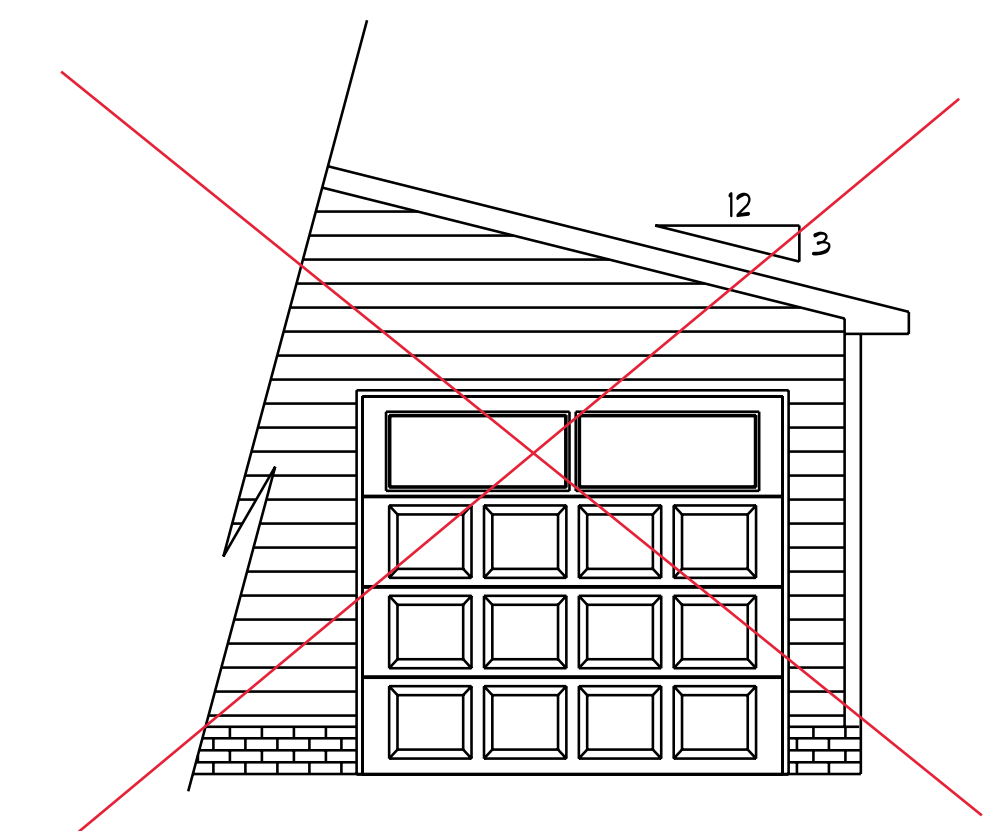

Optional 3rd Garage

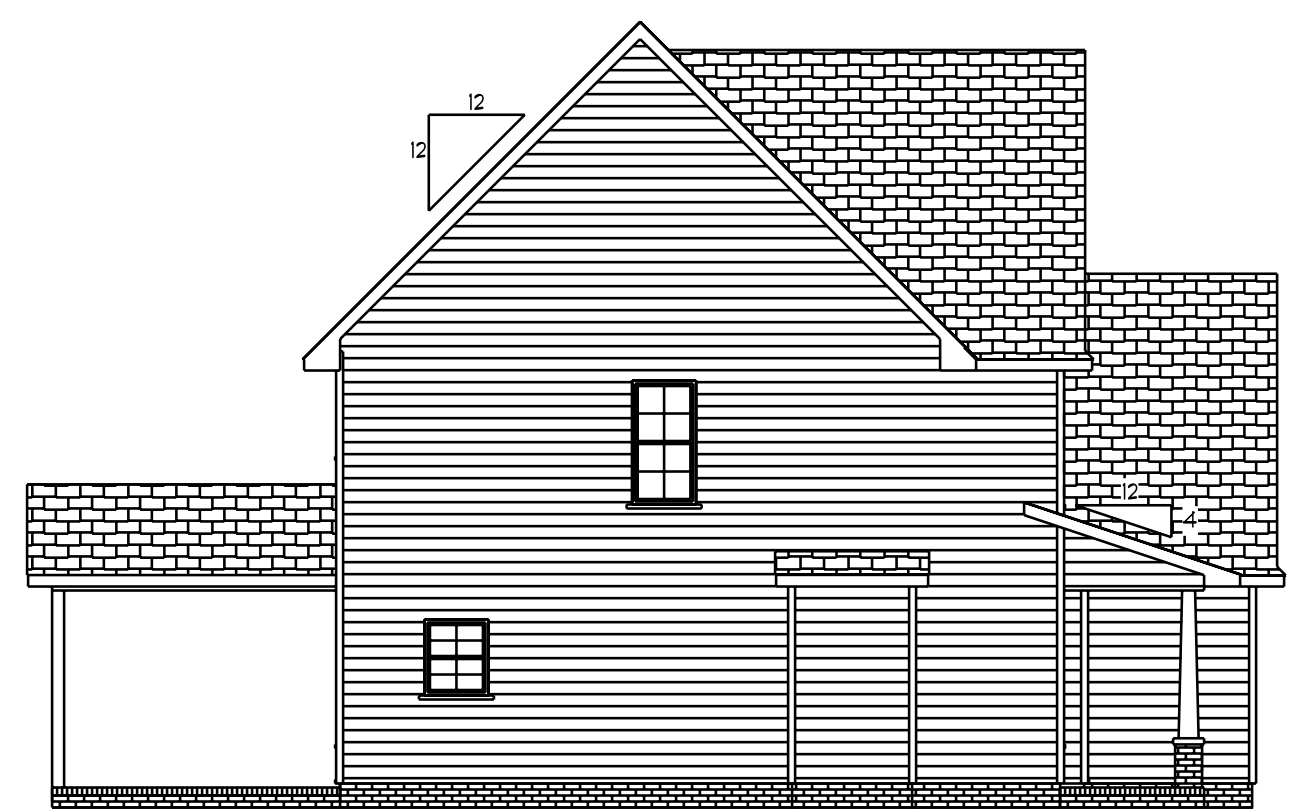

Left Elevation
Scale: 1/8" = 1'0"



Rear Elevation
Scale: 1/8" = 1'0"

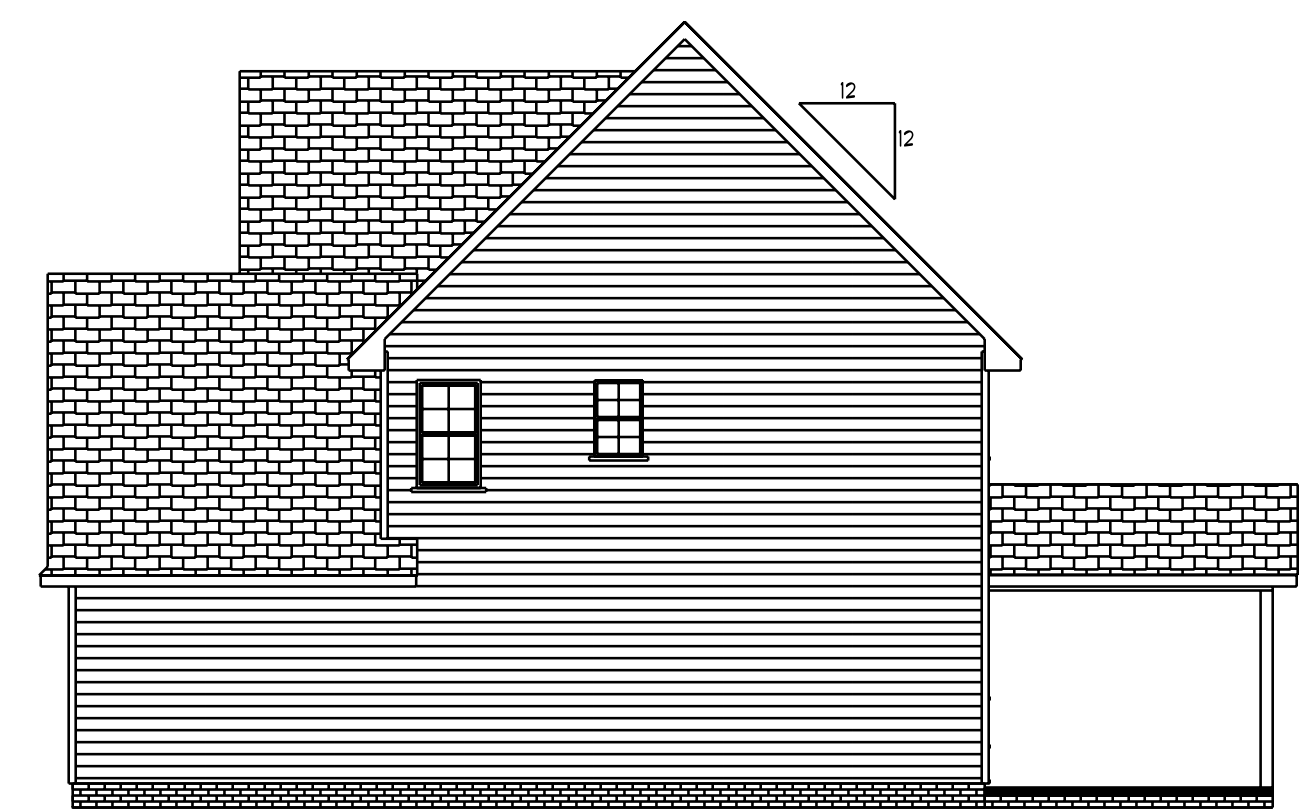

Right Elevation
Scale: 1/8" = 1'0"

DATE: 4/16/2020

REVISED

DRAWING#

SCALE: 1/4"

DRAWN BY

APPROVED

The Ashville

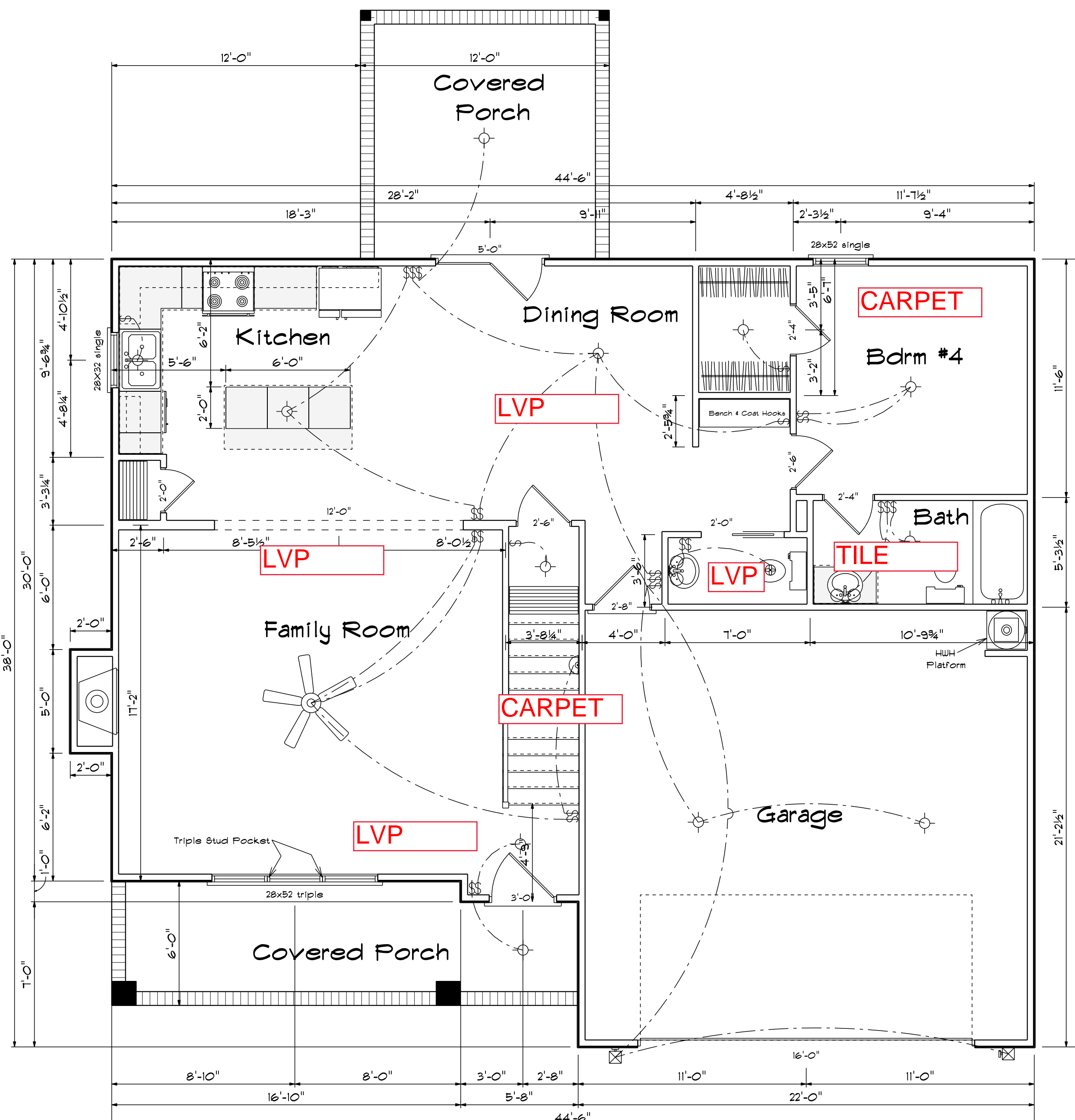

Kitchen Cabinets

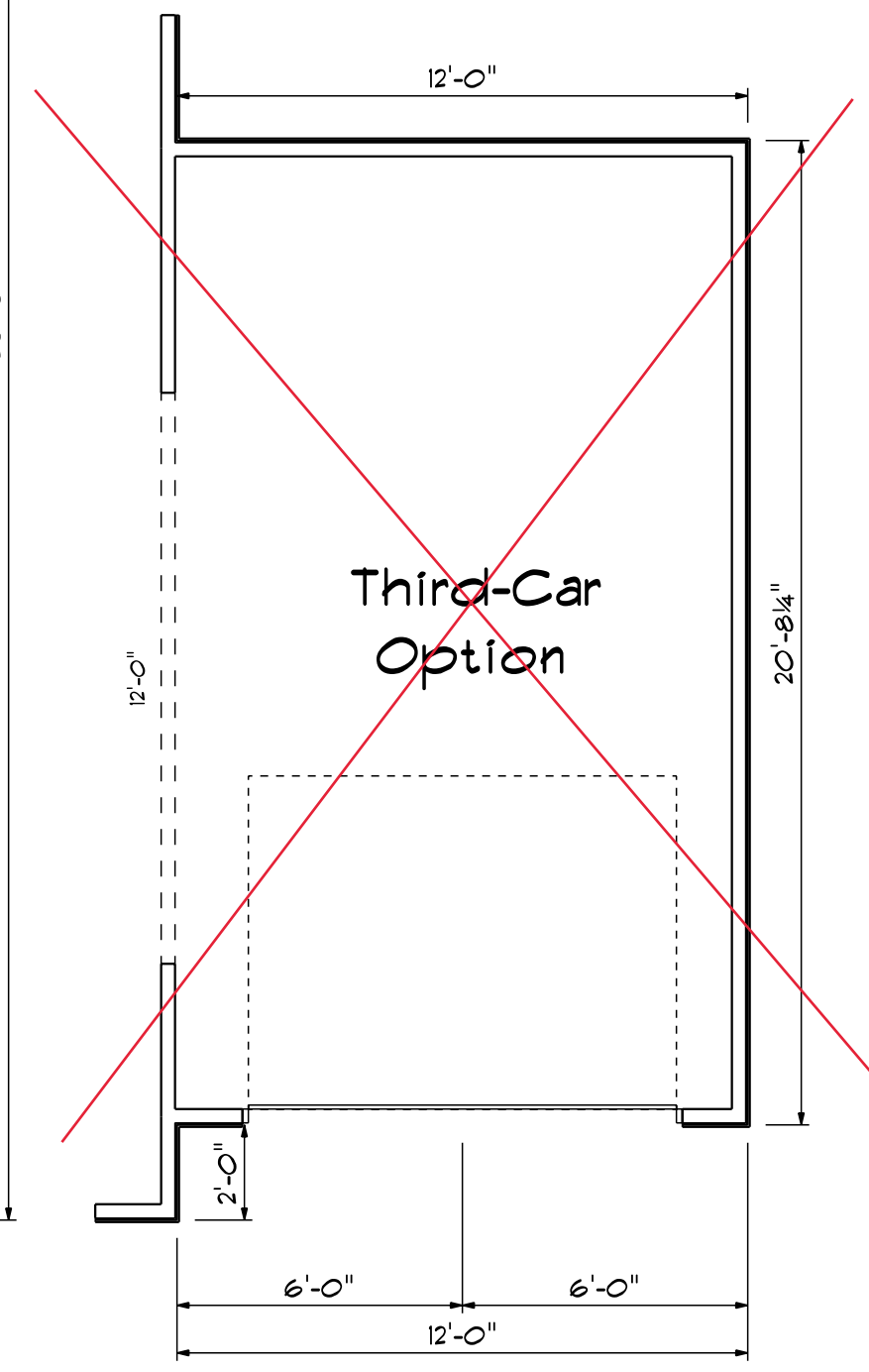
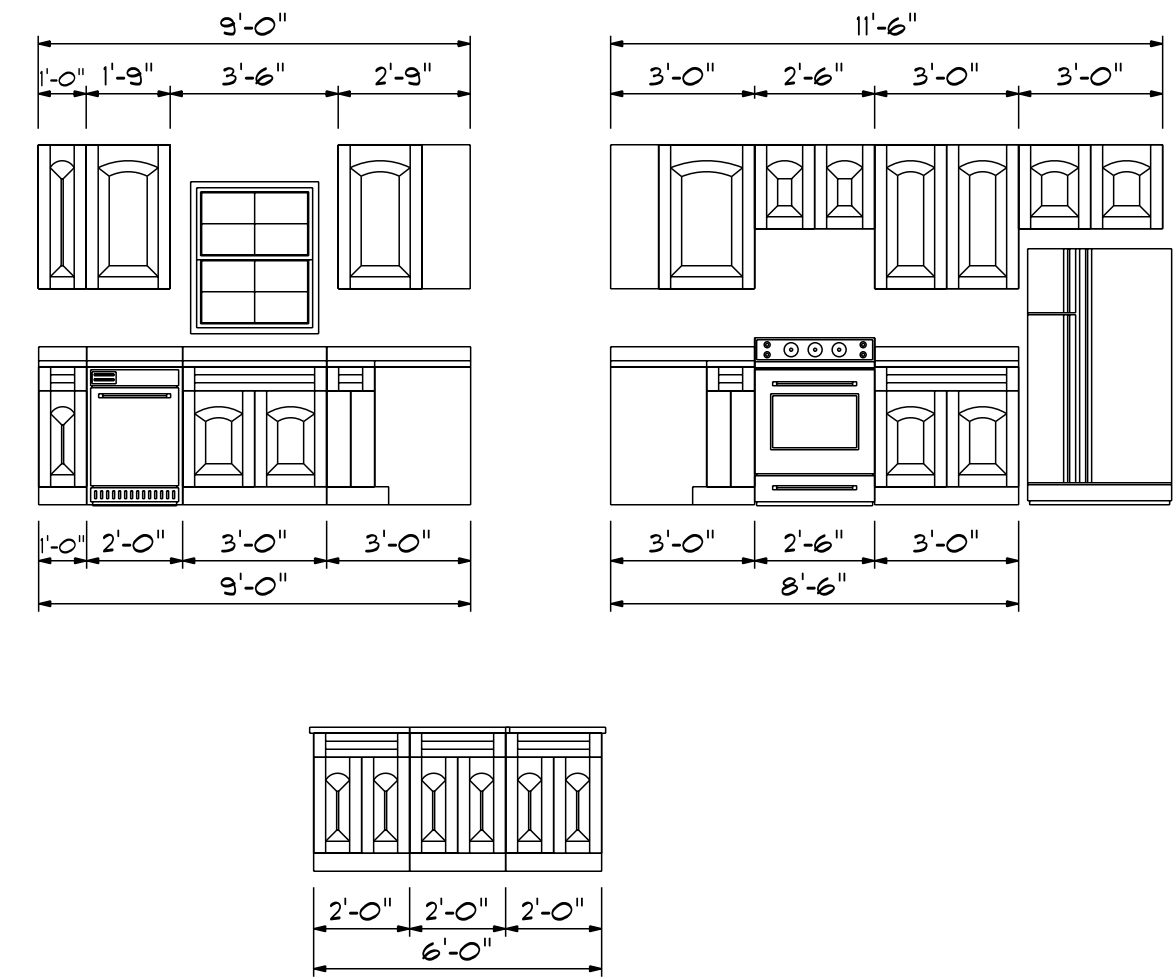

FIRST FLOOR OPENING SCHEDULE			
PRODUCT CODE	SIZE	HINGE	COUNT
36X80 COLONIAL A 1	3'-0"	R	1
60X80 FRENCH A 2	5'-0"	RN	1
192X84 - 8 PANEL - 4 WINDOW	16'-0"	U	1
2-4 Door Unit	2'-4"	R	1
2-4 Door Unit	2'-4"	L	1
2-6 Door Unit	2'-6"	R	2
2-8 Door Unit	2'-8"	L	1
3-0 Doublehung Door Unit	3'-0"	LR	1
20 pocket	2'-0"	N	1
28X32 single	2'-8" x 3'-2"	N	1
28x52 single	2'-8" x 5'-2"	N	1
28x52 triple	8'-0" x 5'-2"	NA	1

Areas	
First Floor	1063
Second Floor	1344
=====	
Total Heated	2407
Garage	461
Front Porch	128
Covered Porch	144
Optionag Garage	257

DATE: 4/16/2020
REVISED
DRAWING#

SCALE: 1/4"
DRAWN BY
APPROVED

Ashville

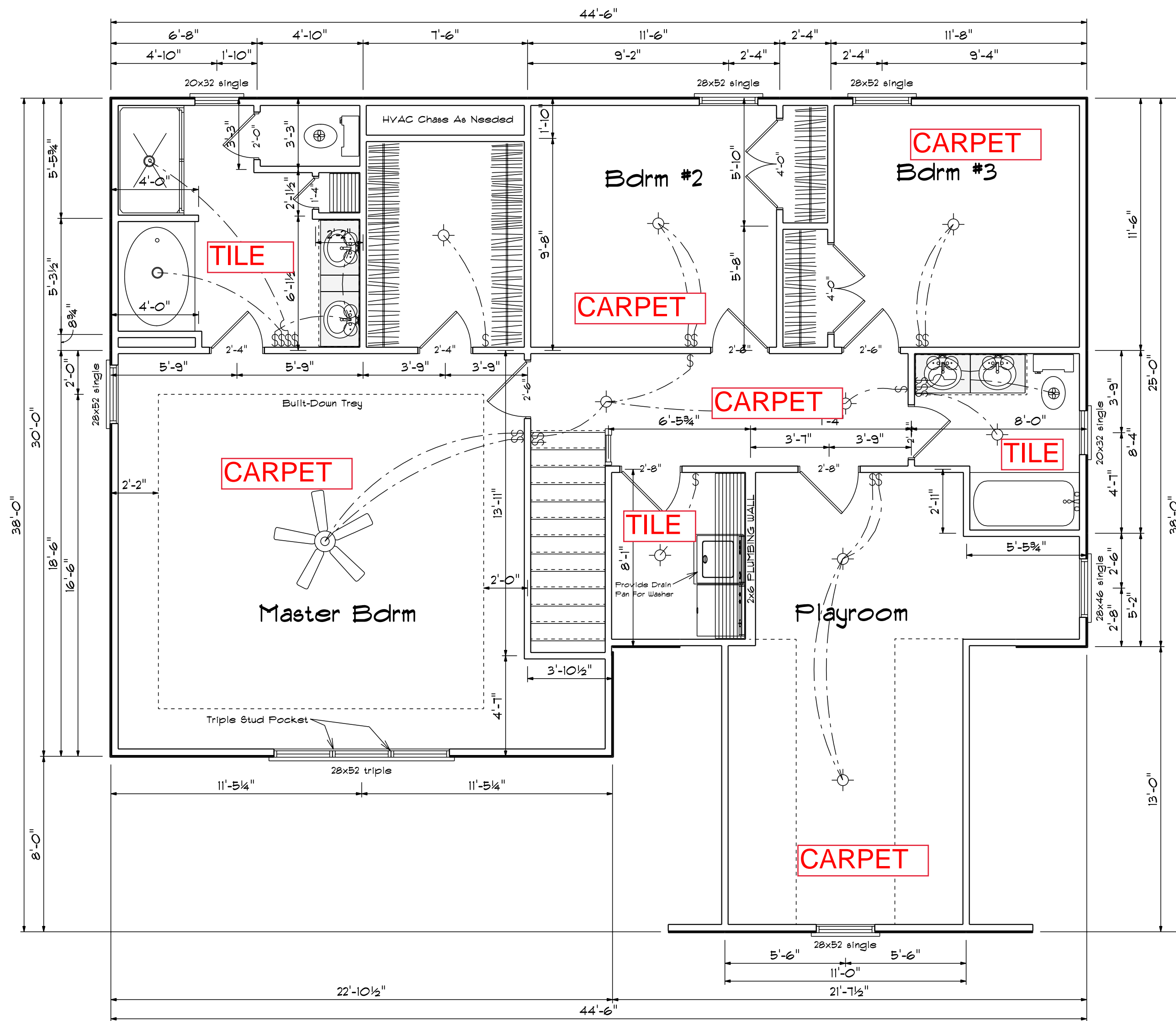

SECOND FLOOR OPENING SCHEDULE			
PRODUCT CODE	SIZE	HINGE	COUNT
1-6 Door Unit	1'-4"	R	1
2-0 Door Unit	2'-0"	R	1
2-4 Door Unit	2'-4"	R	1
2-4 Door Unit	2'-4"	L	2
2-6 Door Unit	2'-6"	R	2
2-6 Door Unit	2'-6"	L	1
2-8 Door Unit	2'-8"	R	2
4-0 Doublehung Door Unit	4'-0"	LR	2
20x32 single	2'-0" x 3'-2"	N	2
28x52 single	2'-8" x 5'-2"	N	5
28x52 triple	8'-0" x 5'-2"	NA	1

Second Floor Plan
 Scale: 1/4" = 1'-0"

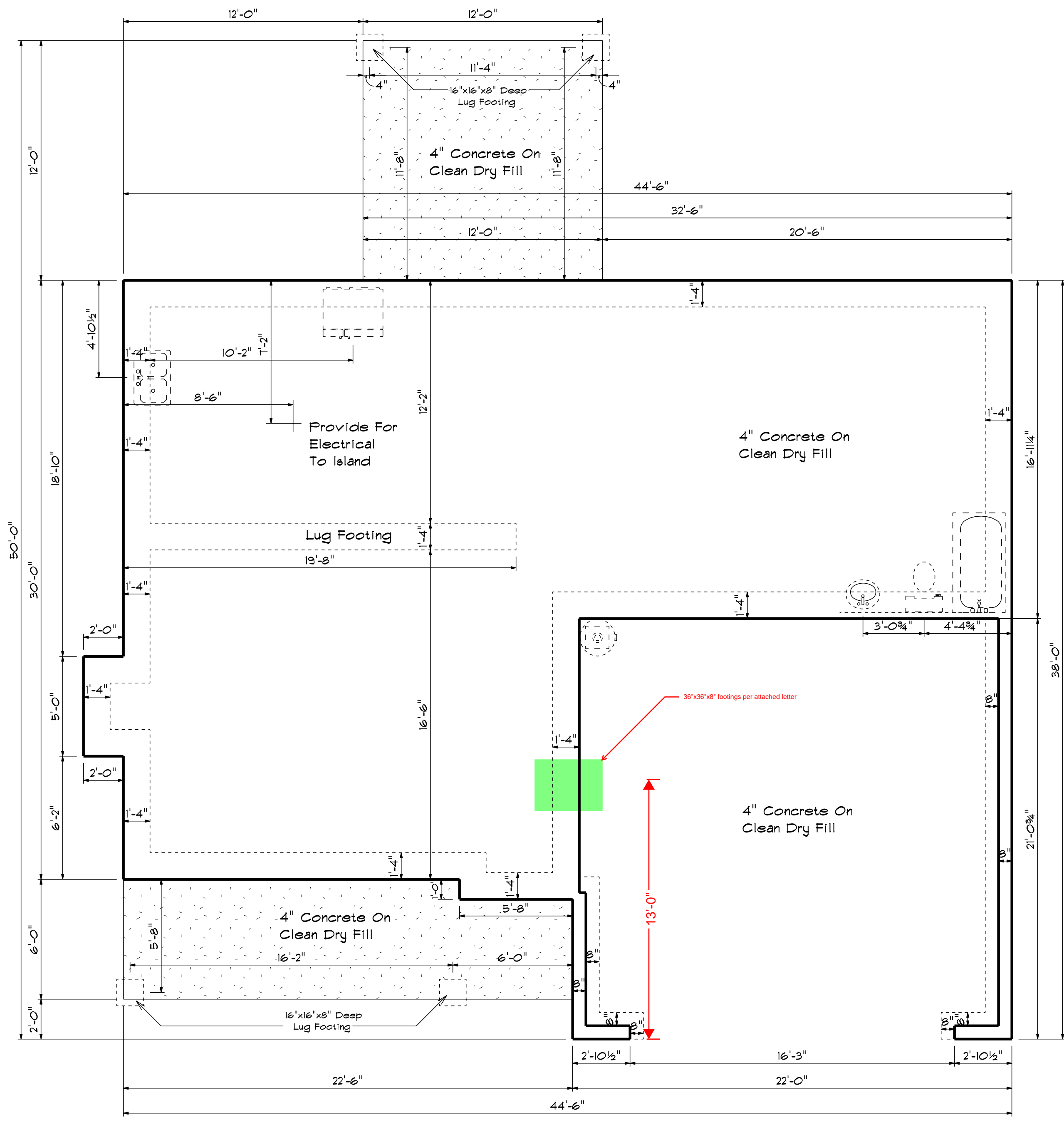

Foundation Plan
 Scale: 1/4" = 1'-0"

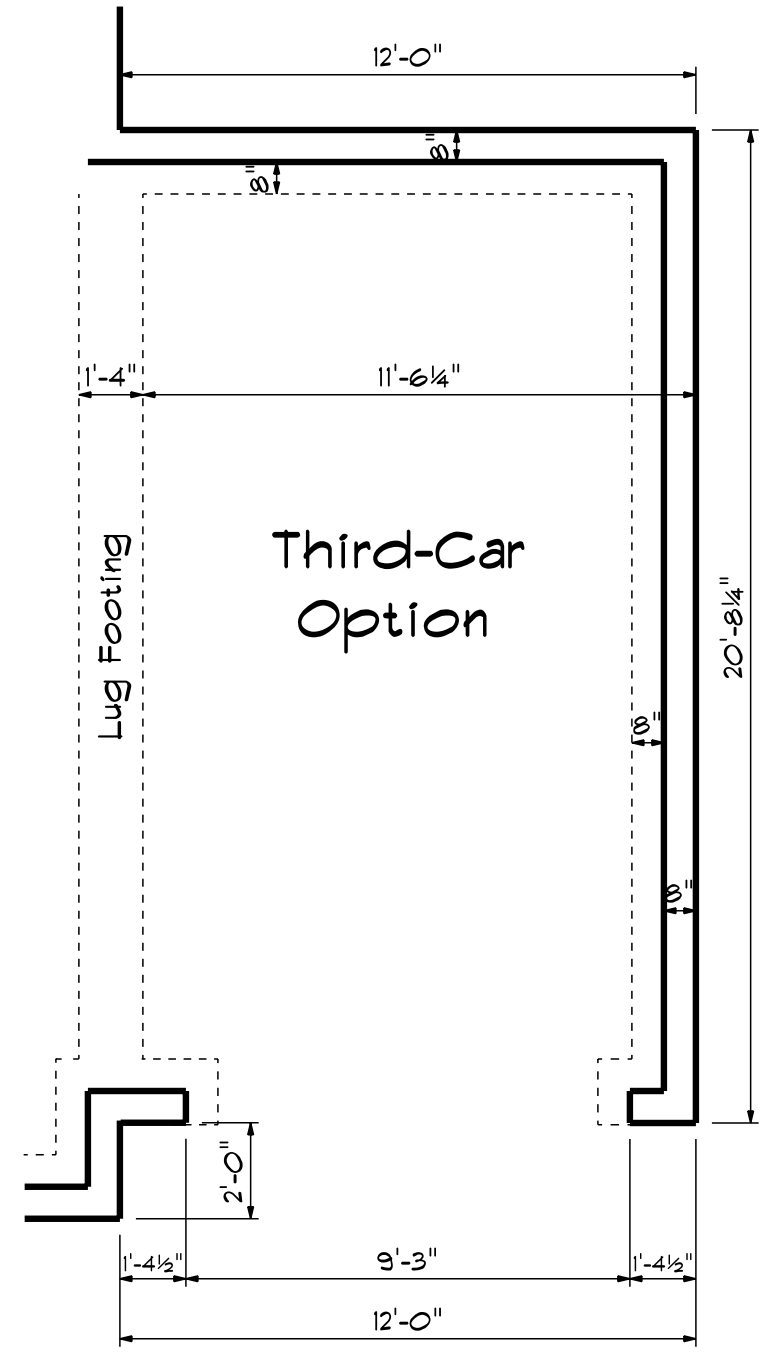
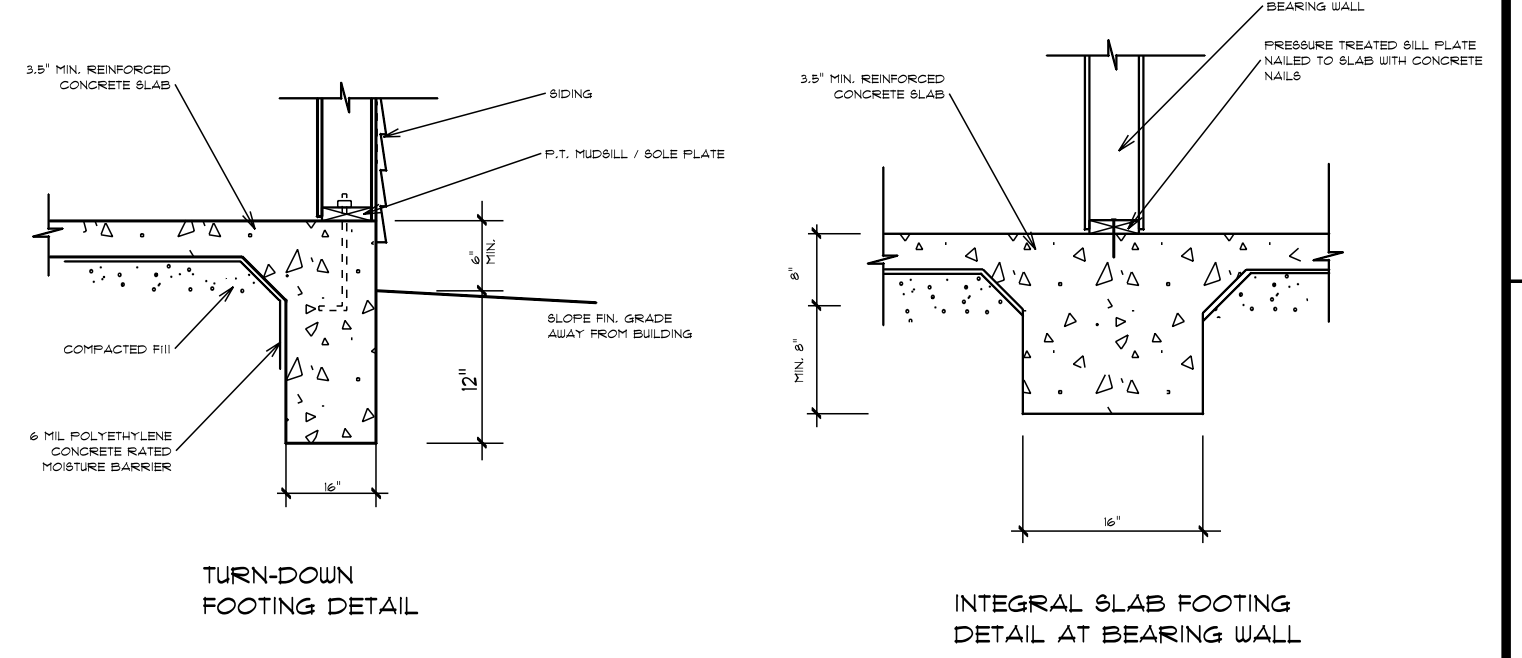

DATE: 4/16/2020
 REVISED
 DRAWING#

SCALE: 1/4"
 DRAWN BY
 APPROVED

The Ashville

Foundation Detail Siding

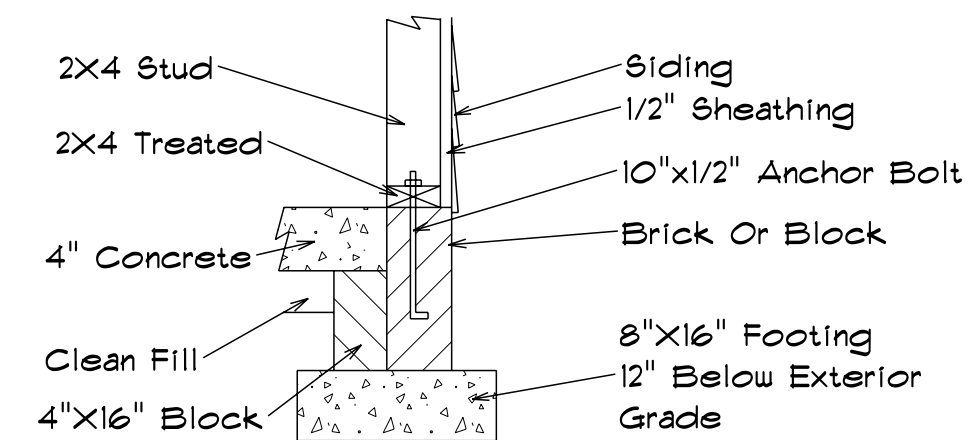

Lug Footing Detail

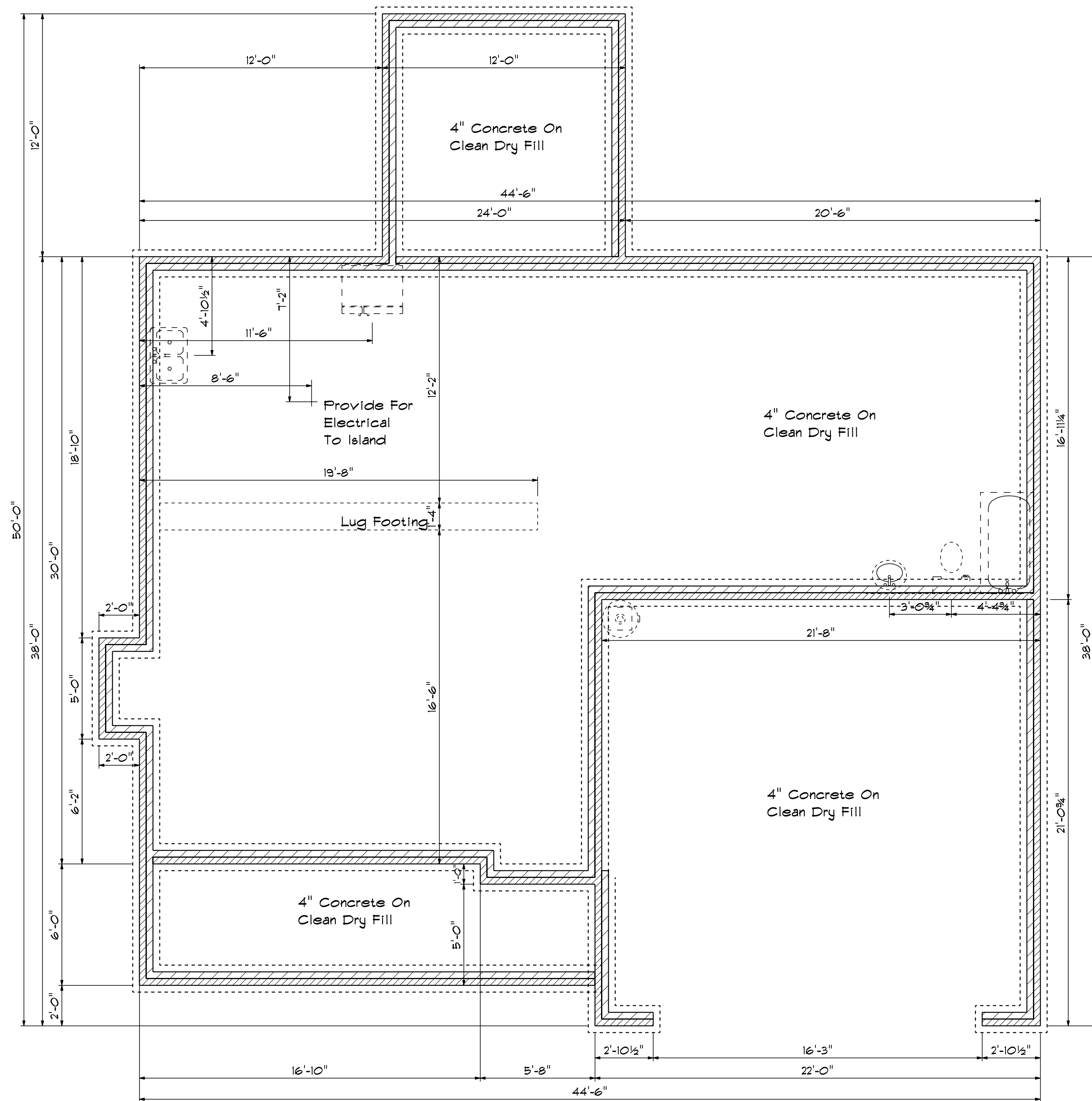
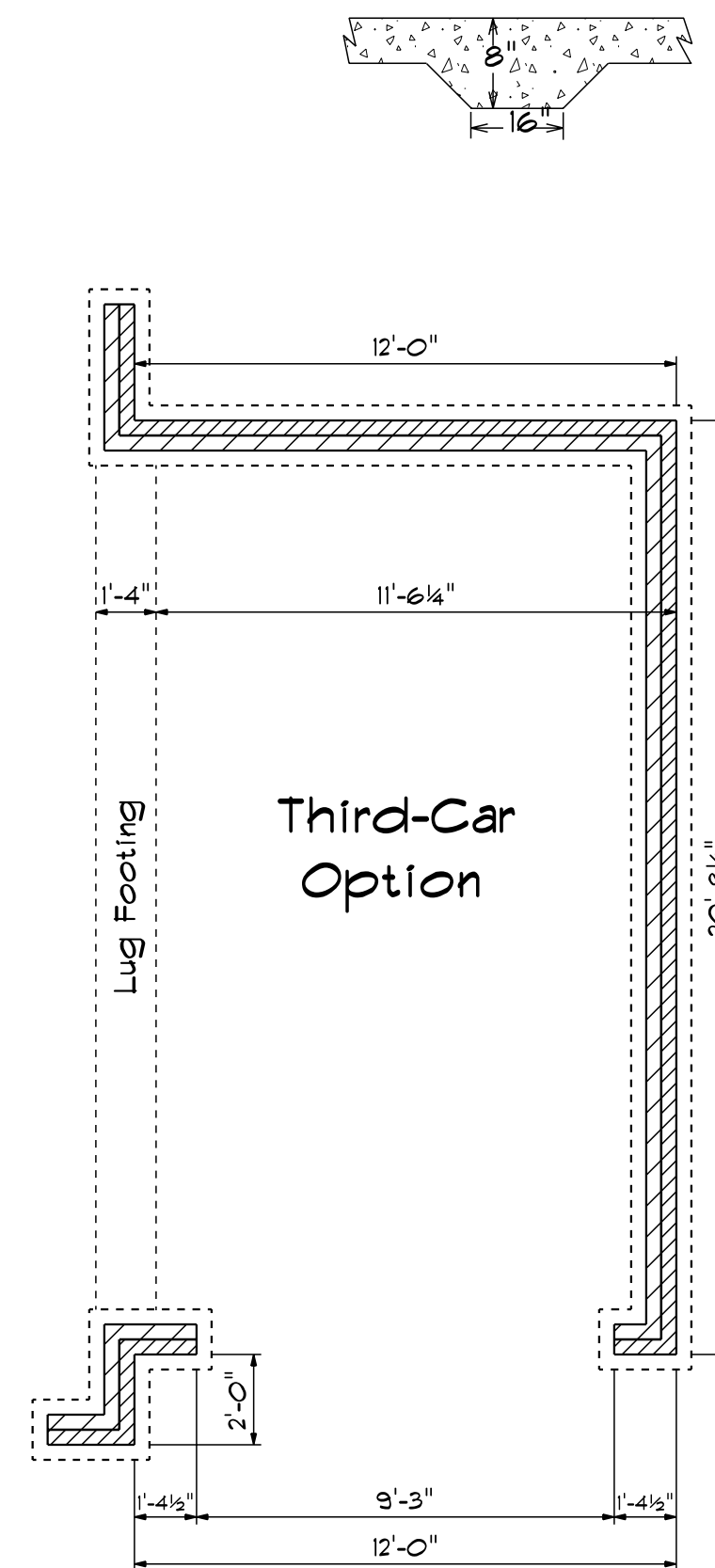

Foundation Plan

Scale: 1/4" = 1'-0"

DATE: 4/16/2020
 REVISED
 DRAWING#

SCALE: 1/4"
 DRAWN BY
 APPROVED

The Ashville



ROOF & FLOOR TRUSSES & BEAMS

Reilly Road Industrial Park
 Fayetteville, N.C. 28309
 Phone: (910) 864-8787
 Fax: (910) 864-4444

Bearing reactions less than or equal to 3000# are deemed to comply with the prescriptive Code requirements. The contractor shall refer to the attached Tables (derived from the prescriptive Code requirements) to determine the minimum foundation size and number of wood studs required to support reactions greater than 3000# but not greater than 15000#. A registered design professional shall be retained to design the support system for any reaction that exceeds those specified in the attached Tables. A registered design professional shall be retained to design the support system for all reactions that exceed 15000#.

Signature _____
David Landry

LOAD CHART FOR JACK STUDS

(BASED ON TABLES ROU0111 & 013)

NUMBER OF JACK STUDS REQUIRED @ EA END OF HEADERS/STROPS		NUMBER OF JACK STUDS REQUIRED @ EA END OF HEADERS/STROPS	
END REACTION (IP TO)	REQ'D STUDS FOR (IP TO) BEAM	END REACTION (IP TO)	REQ'D STUDS FOR (IP TO) BEAM
1700	1	2550	1
3400	2	5100	2
5100	3	7650	3
6800	4	10200	4
8500	5	12750	5
10200	6	15300	6
11900	7		
13600	8		
15300	9		

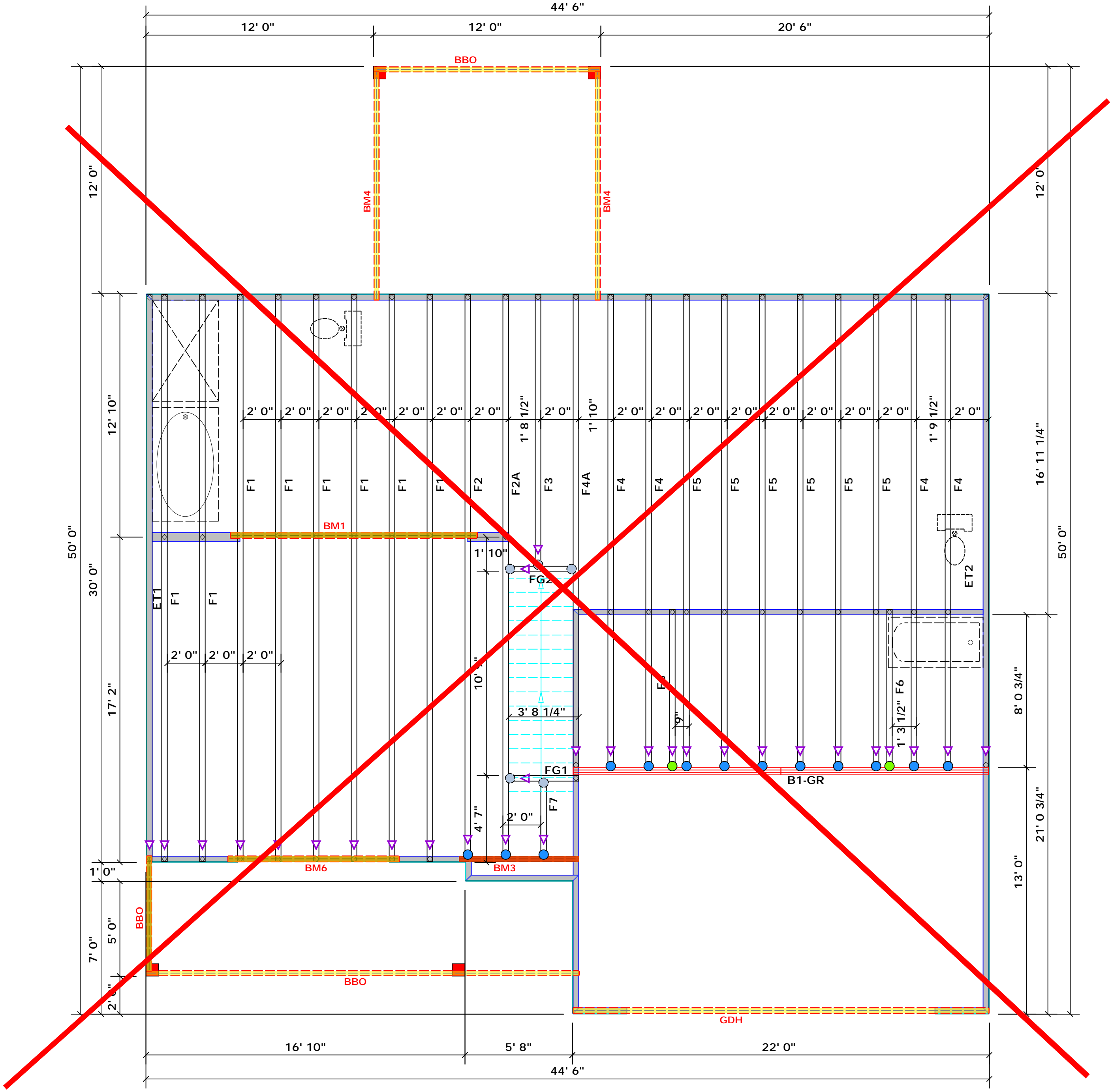

Products				
PlotID	Length	Product	Plies	Net Qty
BM1	13' 0"	1-3/4"x 14" LVL Kerto-S	2	2
BM3	7' 0"	1-3/4"x 14" LVL Kerto-S	2	2
BM4	14' 0"	2x12 SPF No.2	2	4
BM6	9' 0"	1-3/4"x 9-1/4" LVL Kerto-S	2	2
GDH	22' 0"	1-3/4"x 11-7/8" LVL Kerto-S	2	2

1 Truss Placement Plan
 Scale: 1/4"=1'

Dimension Notes

- All exterior wall to wall dimensions are to face of sheathing unless noted otherwise
- All interior wall dimensions are to face of frame wall unless noted otherwise
- All exterior wall to truss dimensions are to face of frame wall unless noted otherwise

All Walls Shown Are Considered Load Bearing

Connector Information					Nail Information	
Sym	Product	Manuf	Qty	Supported Member	Header	Truss
●	HUS410	USP	13	Varies	16d/3-1/2"	16d/3-1/2"
●	MSH422	USP	5	Varies	10d/3"	10d/3"
●	THD410	USP	2	Varies	16d/3-1/2"	10d/3"

Plumbing Drop Notes

- Plumbing drop locations shown are NOT exact.
- Contractor to verify ALL plumbing drop locations prior to setting Floor Trusses.
- Adjust spacing as needed not to exceed 24"oc.

BUILDER	Ben Stout Real Estate	COUNTY	Harnett
JOB NAME	Lot 31 Forest Ridge	ADDRESS	Tanna Place
PLAN	The Ashville	MODEL	Floor
SEAL DATE	N/A	DATE REV.	01/07/21
QUOTE #	Quote #	DRAWN BY	David Landry
JOB #	J1220-5670	SALESMAN	Marshall Naylor

THIS IS A TRUSS PLACEMENT DIAGRAM ONLY. These trusses are designed as individual building components to be incorporated into the building design at the specification of the building designer. See individual design sheets for each truss design identified on the placement drawing. The building designer is responsible for temporary and permanent bracing of the roof and floor system and for the overall structure. The design of the truss support structure including headers, beams, walls, and columns is the responsibility of the building designer. For general guidance regarding bracing, consult BCSI-B1 and BCSI-B3 provided with the truss delivery package or online @ sbcindustry.com



ROOF & FLOOR TRUSSES & BEAMS

Reilly Road Industrial Park
Fayetteville, N.C. 28309
Phone: (910) 864-8787
Fax: (910) 864-4444

Bearing reactions less than or equal to 3000# are deemed to comply with the prescriptive Code requirements. The contractor shall refer to the attached Tables (derived from the prescriptive Code requirements) to determine the minimum foundation size and number of wood studs required to support reactions greater than 3000# but not greater than 15000#. A registered design professional shall be retained to design the support system for any reaction that exceeds those specified in the attached Tables. A registered design professional shall be retained to design the support system for all reactions that exceed 15000#.

Signature _____
David Landry

LOAD CHART FOR JACK STUDS

(BASED ON TABLES R001L1 & R13)

NUMBER OF JACK STUDS REQUIRED @ EA END OF HEADERS/GIRDERS		NUMBER OF JACK STUDS REQUIRED @ EA END OF HEADERS/GIRDERS	
END REACTION (IP-TON)	REQ'D STUDS FOR 10' BY BEAM	END REACTION (IP-TON)	REQ'D STUDS FOR 10' BY BEAM
1700	1	2550	1
3400	2	5100	2
5100	3	7650	3
6800	4	10200	4
8500	5	12750	5
10200	6	15300	6
11900	7		
13600	8		
15300	9		

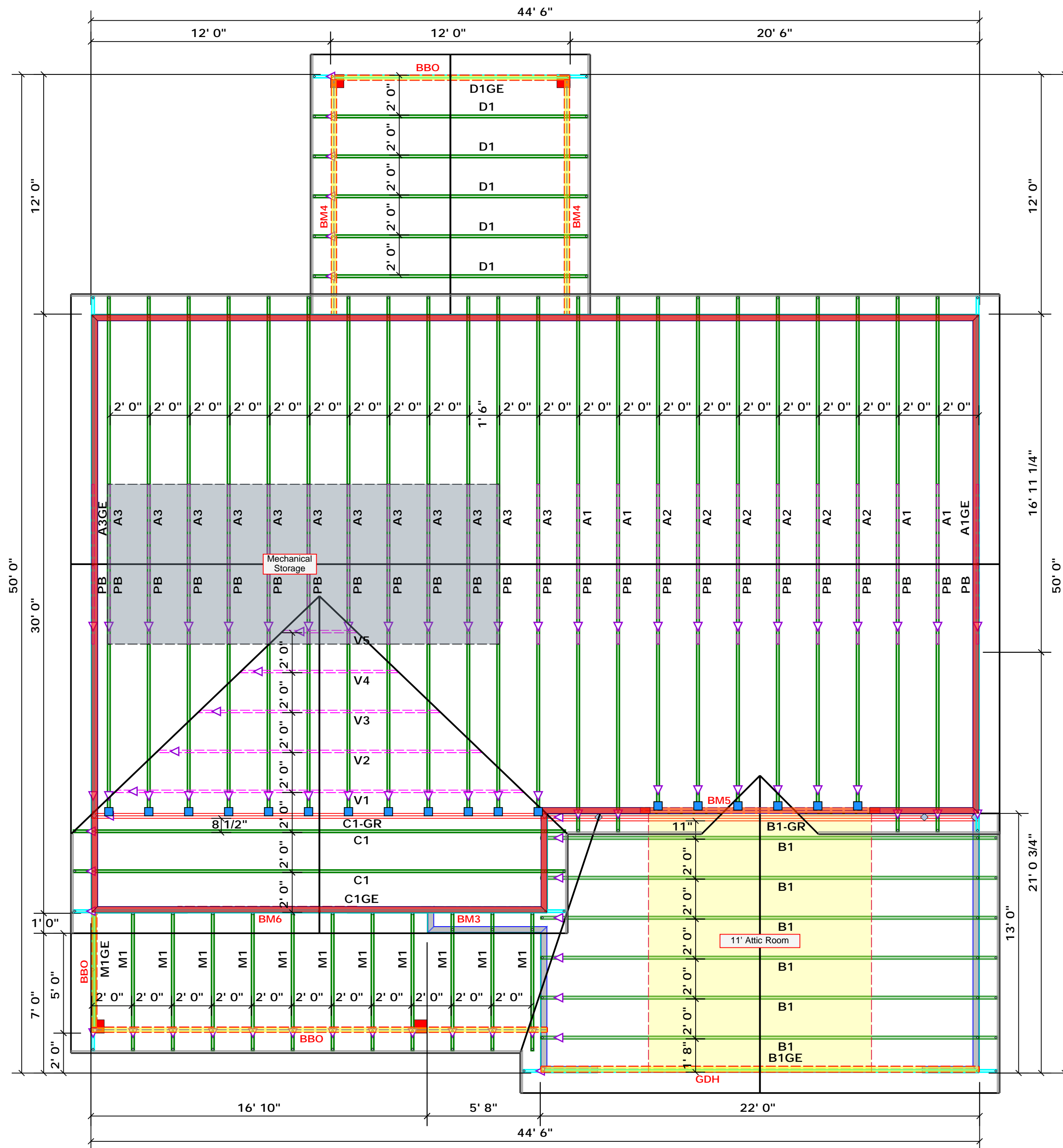

Products				
PlotID	Length	Product	Plies	Net Qty
BM5	12' 0"	1-3/4"x 11-7/8" LVL Kerto-S	2	2

Hatch Legend	
	Padded HVAC
	Second Floor Walls

Roof Area = 2768.4 sq.ft.
Ridge Line = 92.31 ft.
Hip Line = 0 ft.
Horiz. OH = 137.81 ft.
Raked OH = 181.25 ft.
Decking = 95 sheets

1 Truss Placement Plan
Scale: 1/4"=1'

- Dimension Notes**
- All exterior wall to wall dimensions are to face of sheathing unless noted otherwise
 - All interior wall dimensions are to face of frame wall unless noted otherwise
 - All exterior wall to truss dimensions are to face of frame wall unless noted otherwise

All Walls Shown Are Considered Load Bearing

Connector Information					Nail Information	
Sym	Product	Manuf	Qty	Supported Member	Header	Truss
	HUS26	USP	18	Varies	16d/3-1/2"	16d/3-1/2"

BUILDER	Ben Stout Real Estate	COUNTY	Harnett
JOB NAME	Lot 31 Forest Ridge	ADDRESS	Tanna Place
PLAN	The Ashville	MODEL	Roof
SEAL DATE	N/A	DATE REV.	01/07/21
QUOTE #	Quote #	DRAWN BY	David Landry
JOB #	J1220-5670	SALESMAN	Marshall Naylor

THIS IS A TRUSS PLACEMENT DIAGRAM ONLY. These trusses are designed as individual building components to be incorporated into the building design at the specification of the building designer. See individual design sheets for each truss design identified on the placement drawing. The building designer is responsible for temporary and permanent bracing of the roof and floor system and for the overall structure. The design of the truss support structure including headers, beams, walls, and columns is the responsibility of the building designer. For general guidance regarding bracing, consult BCSI-B1 and BCSI-B3 provided with the truss delivery package or online @ sbcindustry.com

E. Randolph Marshall
7575 McArtans Ford
Linden, NC 28356
(910) 850 5874

Randolph@RandolphMarshall.com

Cody Sharpless
Ben Stout Construction
409 Chicago Drive
Unit 103
Fayetteville, NC

June 20, 2021

Subject: The Ashville House Plan
Harnett County

I reviewed the construction drawings and the truss and beam designs furnished by Comtech. Comtech also provided the reaction loads.

At the junction where trusses C1GR and B1GR meet, there is a significant load being transferred to the footing below. However, the 36" x 36" x 8" footing will support the load.

Truss C1GR is a two-ply, and truss B1GR is a three-ply truss. Fasten the truss members together according to the note on the truss design sheets.

Both trusses require larger support columns. Follow the dimensions on the truss drawings and install the correct number of studs. Fasten the studs together with two rows of 10d nails in each stud.

The design depicted in the drawings and trusses cut-sheets is structurally adequate. I have no structural concerns regarding this house.

Please call my office if you have questions or need additional engineering support.

Sincerely,



E. Randolph Marshall, PE

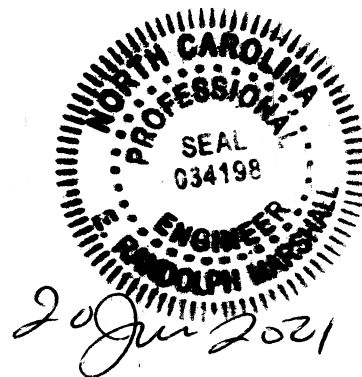



ROOF & FLOOR TRUSSES & BEAMS

Reilly Road Industrial Park
Fayetteville, N.C. 28309
Phone: (910) 864-8787
Fax: (910) 864-4444

Bearing reactions less than or equal to 3000# are deemed to comply with the prescriptive Code requirements. The contractor shall refer to the attached Tables (derived from the prescriptive Code requirements) to determine the minimum foundation size and number of wood studs required to support reactions greater than 3000# but not greater than 15000#. A registered design professional shall be retained to design the support system for any reaction that exceeds those specified in the attached Tables. A registered design professional shall be retained to design the support system for all reactions that exceed 15000#.

Signature _____
David Landry

LOAD CHART FOR JACK STUDS

(BASED ON TABLES ROEHLIC & CO.)
NUMBER OF JACK STUDS REQUIRED @ EA END OF HEADERS/STRIPS

END REACTION (IP / FT)	REQ'D STUDS FOR 10' HEADERS	END REACTION (IP / FT)	REQ'D STUDS FOR 10' STRIPS	END REACTION (IP / FT)	REQ'D STUDS FOR 10' HEADERS
1700	1	2550	1	3400	1
3400	2	5100	2	6800	2
5100	3	7650	3	10200	3
6800	4	10200	4	13600	4
8500	5	12750	5	17000	5
10200	6	15300	6		
11900	7				
13600	8				
15300	9				

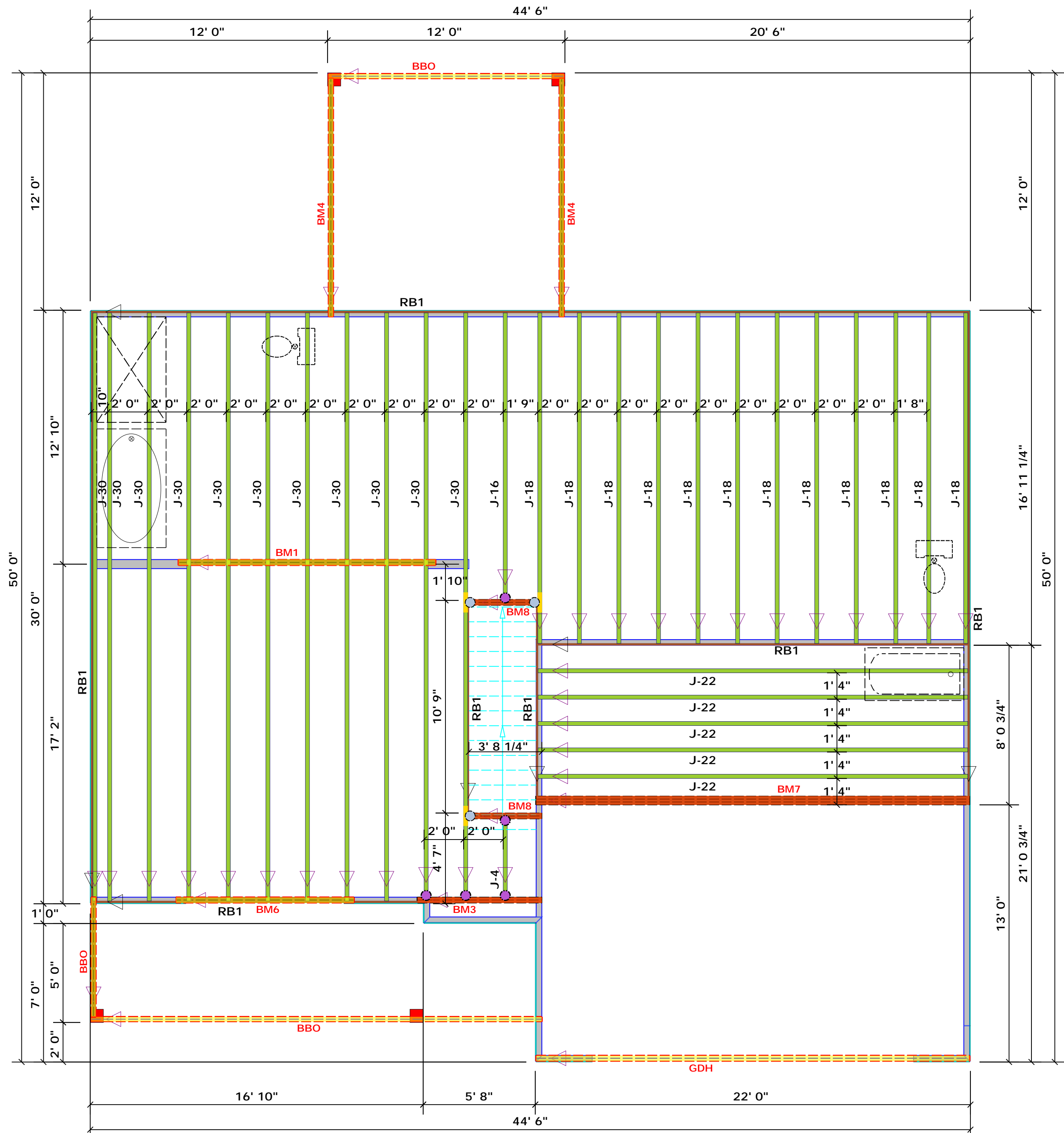

Products				
PlotID	Length	Product	Plies	Net Qty
BM1	13' 0"	1-3/4"x 14" LVL Kerto-S	2	2
BM3	7' 0"	1-3/4"x 14" LVL Kerto-S	2	2
BM4	14' 0"	2x12 SPF No.2	2	4
BM6	9' 0"	1-3/4"x 9-1/4" LVL Kerto-S	2	2
BM7	22' 0"	1-3/4"x 18" LVL Kerto-S	3	3
BM8	4' 0"	1-3/4"x 14" LVL Kerto-S	2	4
GDH	22' 0"	1-3/4"x 11-7/8" LVL Kerto-S	2	2
J-4	4' 0"	14" NI-40x	1	1
J-16	16' 0"	14" NI-40x	1	1
J-18	18' 0"	14" NI-40x	1	12
J-22	22' 0"	14" NI-40x	1	5
J-30	30' 0"	14" NI-40x	1	11
RB1	12' 0"	1 1/8" x 14" Rim Board	1	14

1 Truss Placement Plan
Scale: 1/4"=1'

Dimension Notes

- All exterior wall to wall dimensions are to face of sheathing unless noted otherwise
- All interior wall dimensions are to face of frame wall unless noted otherwise
- All exterior wall to truss dimensions are to face of frame wall unless noted otherwise

All Walls Shown Are Considered Load Bearing

Connector Information					Nail Information	
Sym	Product	Manuf	Qty	Supported Member	Header	Truss
THF25140	USP	5	NA	10d/3"	10d/3"	
MSH422	USP	3	Varies	10d/3"	10d/3"	

Plumbing Drop Notes

- Plumbing drop locations shown are NOT exact.
- Contractor to verify ALL plumbing drop locations prior to setting Floor Trusses.
- Adjust spacing as needed not to exceed 24"oc.

BUILDER	Ben Stout Real Estate	COUNTY	Harnett
JOB NAME	Lot 31 Forest Ridge	ADDRESS	Tanna Place
PLAN	The Ashville	MODEL	Floor
SEAL DATE	N/A	DATE REV.	08/02/21
QUOTE #	Quote #	DRAWN BY	David Landry
JOB #	J1220-5672	SALESMAN	Marshall Naylor

THIS IS A TRUSS PLACEMENT DIAGRAM ONLY. These trusses are designed as individual building components to be incorporated into the building design at the specification of the building designer. See individual design sheets for each truss design identified on the placement drawing. The building designer is responsible for temporary and permanent bracing of the roof and floor system and for the overall structure. The design of the truss support structure including headers, beams, walls, and columns is the responsibility of the building designer. For general guidance regarding bracing, consult BCSI-B1 and BCSI-B3 provided with the truss delivery package or online @ sbcindustry.com