

REGES

CANE MILL ESTATES
LOT 26



PLAN ID 070120

**110 VILLAGE TRAIL SUITE 215
WOODSTOCK, GA. 30188**

DRAWING INDEX	
A0.0	COVER SHEET
A1.1	FRONT ELEVATIONS
A2.1	SIDE & REAR ELEVATIONS
A3.1	SLAB FOUNDATIONS
A5.1	FIRST FLOOR PLANS & DETAILS
A5.2	SECOND FLOOR PLANS & DETAILS
A6.1	ROOF PLANS
A7.2-A7.3	ELECTRICAL PLANS

AREA TABULATION	
FIRST FLOOR	1404
SECOND FLOOR	1128
TOTAL	2532
GARAGE	389
FRONT PORCH (COVERED)	146
REAR PAD	9

PLAN REVISIONS			
DATE	BY	REVISION	PAGE #
4/17/2018	AW	Redesigned layout - see revision sheet	ALL
9/25/2018	AW	Prototype walk changes - see revision sheet	ALL
3/14/2019	AW	Moved PDS toward rear of house so not over stairs	A5.2
3/26/2019	AW	Flipped swing of Owner's W.I.C. door	A5.1, A7.2
7/23/2019	AW	Added grade beam next to Laundry to match engineered slab plan	A3.1
7/1/2020	AW	PCR #3856 changed rear wall of garage to 2x6	A3.1-A8.1
2/1/2021	AW	PCR #4265 Revised material note on B massing dormer, added 2 chases to 2nd floor	A1.2,A1.5,A1.8, A5.2,A7.4-4.1

GOVERNMENTAL CODES & STANDARDS
HOME TO BE BUILT TO CONFORM TO ALL APPLICABLE LOCAL CODES, PRACTICES AND STANDARDS

BUILDING CODE ANALYSIS / DESIGN CRITERIA
HOME TO BE BUILT TO MEET OR EXCEED ALL LOCAL CODES AND DESIGN CRITERIA

CANE MILL ESTATES LOT 26

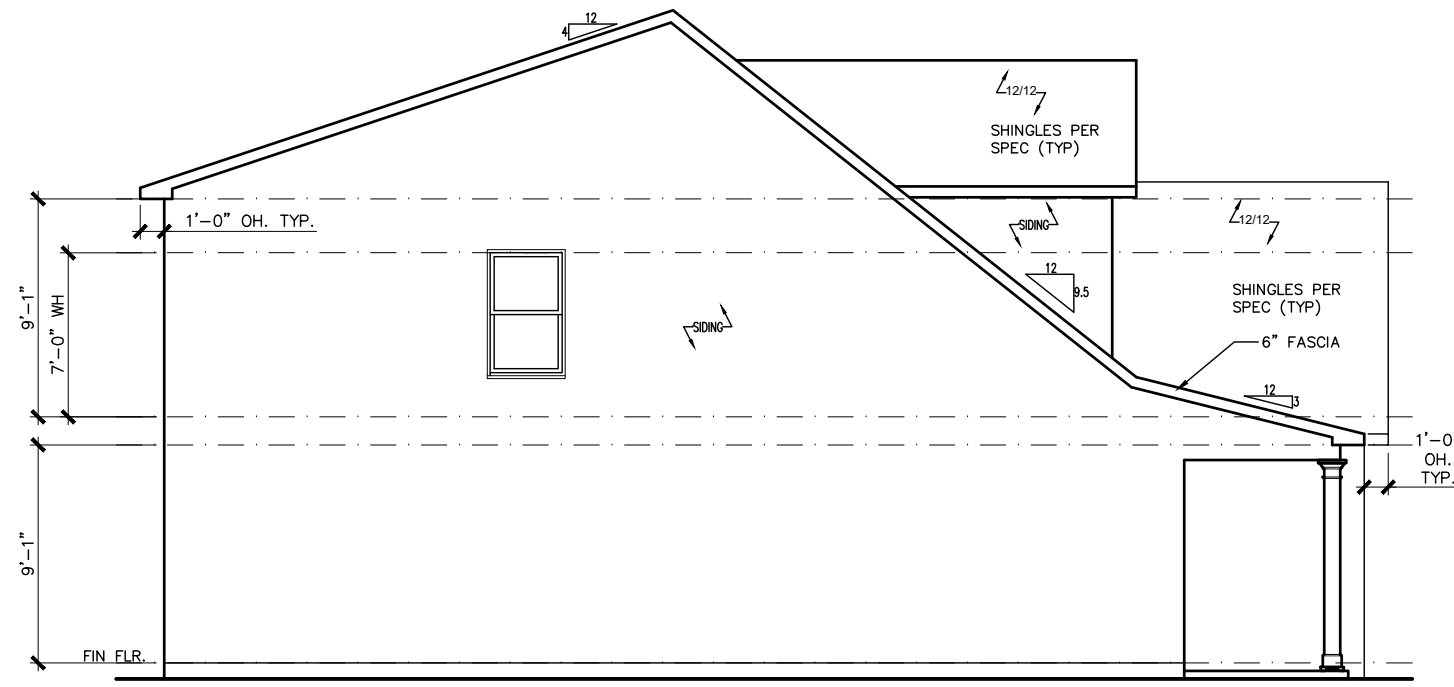

LEFT ELEVATION "E"

SCALE: 1/8" = 1'-0"

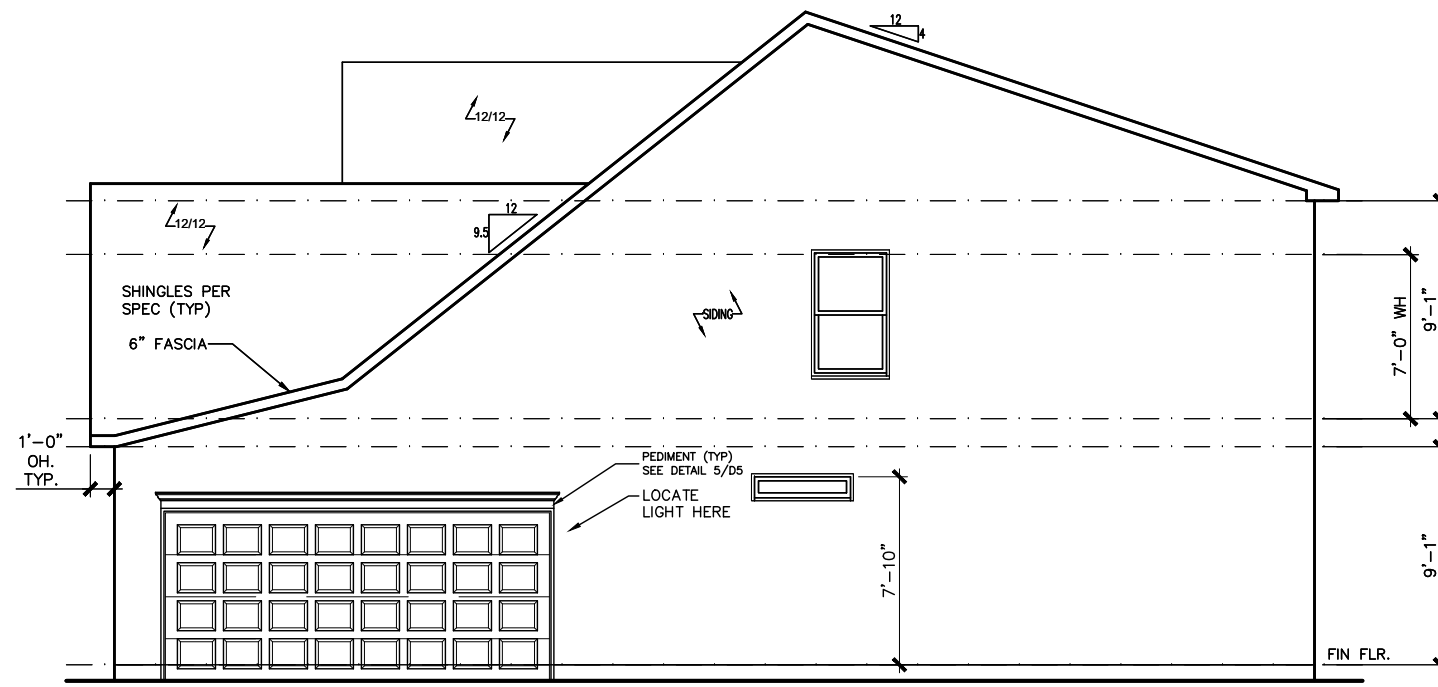

RIGHT ELEVATION "E"

SCALE: 1/8" = 1'-0"

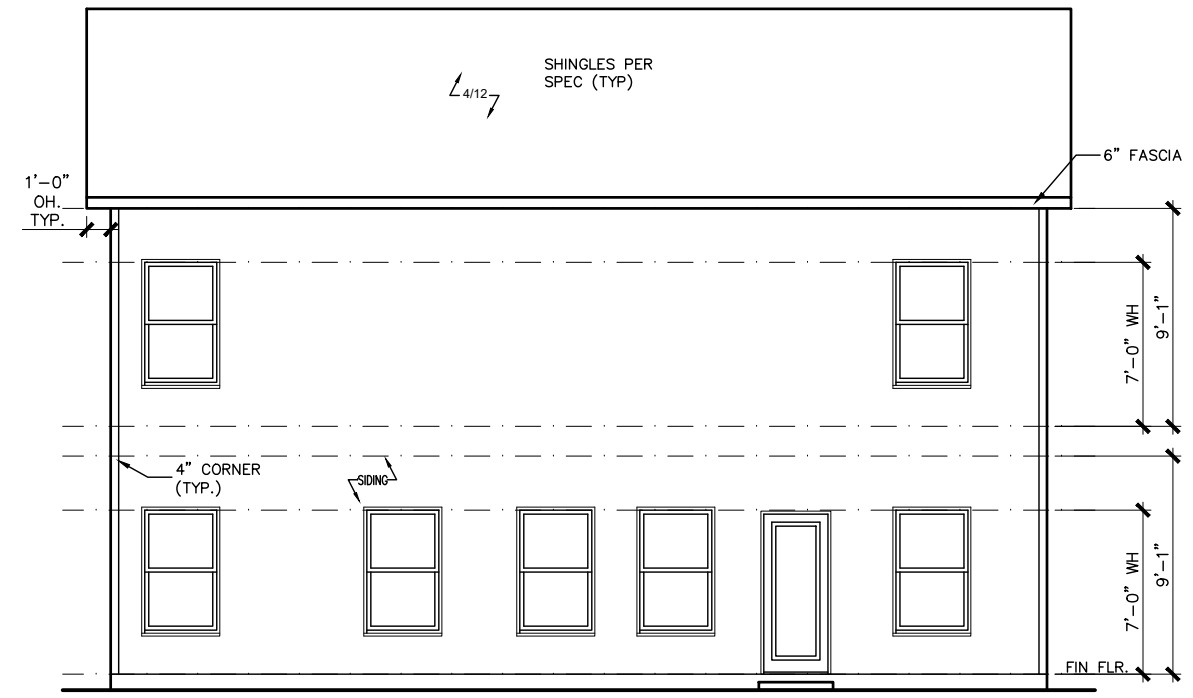

REAR ELEVATION "E"

SCALE: 1/8" = 1'-0"

DATE	REVISION	BY	#	#	#	#	#



ELEVATIONS
SIDES AND REAR
REGES

SMITH DOUGLAS HOMES
110 VILLAGE TRAIL
SUITE 115
WOODSTOCK, GA 30188
www.smithdouglas.com

SMITH DOUGLAS HOMES
expressly reserves it's
property rights in these
plans and drawings.
These plans and related
drawings are not to be
reproduced without written
consent from SMITH
DOUGLAS HOMES.

BY: ED	CHK: AW
DATE: 5/26/21	
FACADE OPT: B	
PLAN ID:	
FND: ALL	ELEV: E
PAGE NO: A2.1	

CANE MILL ESTATES LOT 26

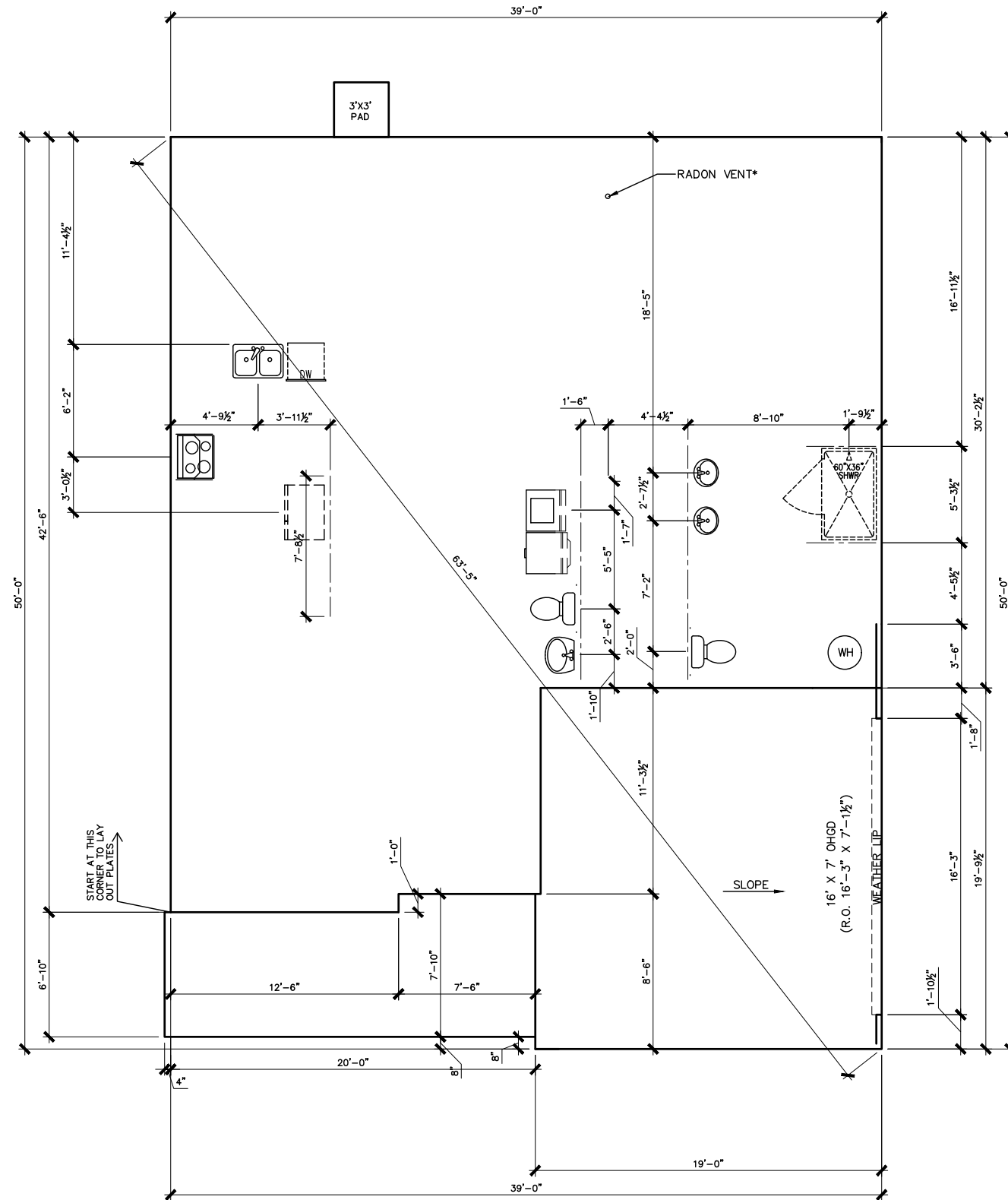

*RADON VENT
PROVIDED PER
LOCAL CODE

REFER TO DETAIL 3/D1 FOR
BRICK LEDGE DETAIL WHEN
BRICK VENEER IS CHOSEN

SLAB PLAN

SCALE: 1/8" = 1'-0"

DATE	REVISION	BY	#



FOUNDATION PLAN
SLAB PLAN
REGES

SMITH DOUGLAS HOMES
110 VILLAGE TRAIL
SUITE 115
WOODSTOCK, GA 30188
www.smithdouglas.com

SMITH DOUGLAS HOMES
expressly reserves its
property rights in these
plans and drawings.
These plans and related
drawings are not to be
reproduced without written
consent from SMITH
DOUGLAS HOMES.

BY: ED	CHK: AW
DATE: 5/26/21	
FACADE OPT: B	
PLAN ID:	
FND: ALL	ELEV: E
PAGE NO: A3.1	

CANE MILL ESTATES LOT 26

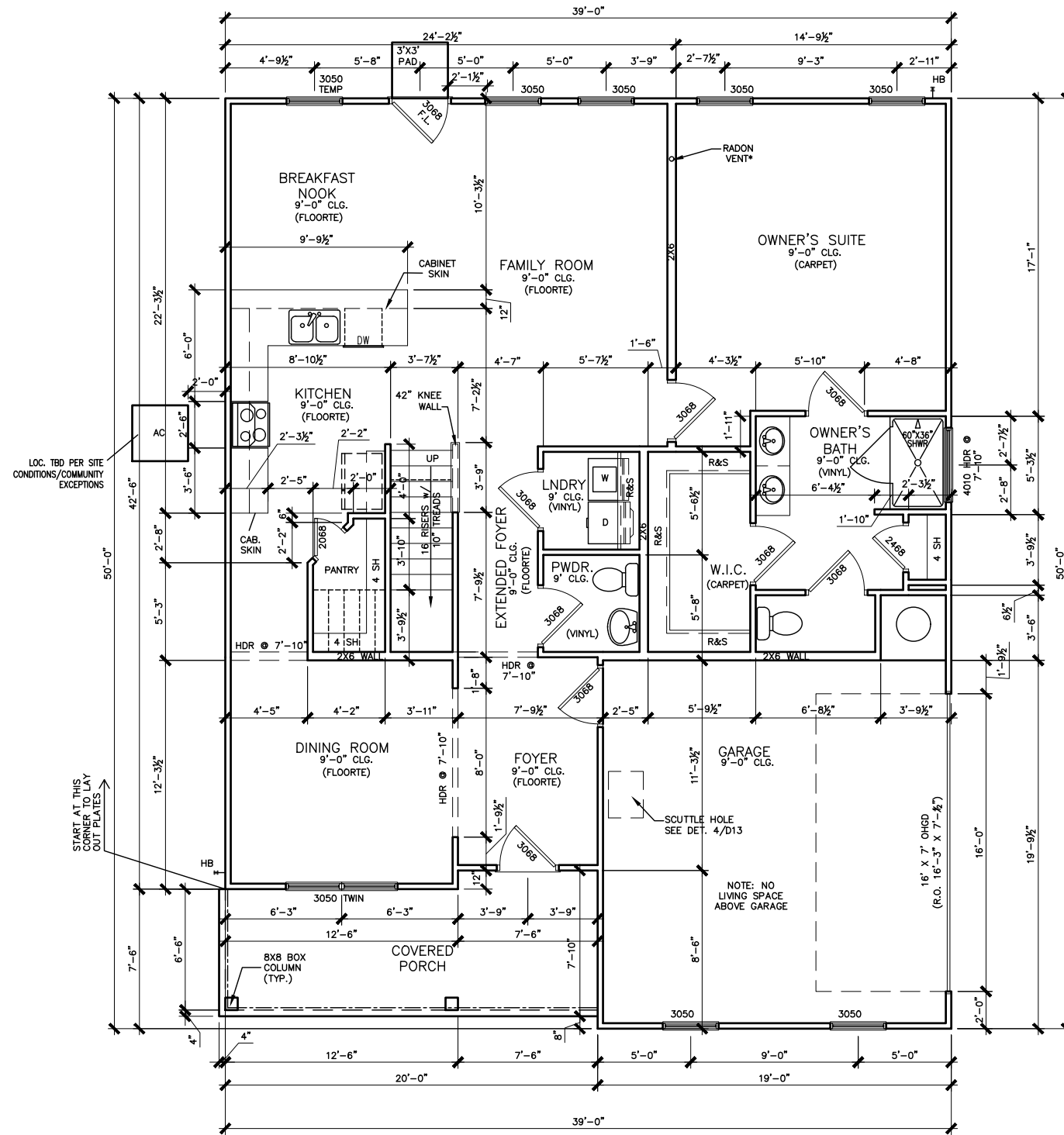

*RADON VENT PROVIDED
PER LOCAL CODE

REFER TO MANUFACTURER'S
SPECS. FOR DRAIN LOCATIONS
ON DETAIL SHEETS
D12,D12.1,D12.2 & D12.3

FIRST FLOOR PLAN

SCALE: 1/8" = 1'-0"

BY	#	REVISION	DATE



FLOOR PLAN
FIRST FLOOR
REGES

SMITH DOUGLAS HOMES
110 VILLAGE TRAIL
SUITE 115
WOODSTOCK, GA 30188
www.smithdouglas.com

SMITH DOUGLAS HOMES
expressly reserves it's
property rights in these
plans and drawings.
These plans and related
drawings are not to be
reproduced without written
consent from SMITH
DOUGLAS HOMES.

BY: ED	CHK: AW
DATE: 5/26/21	
FACADE OPT: B	
PLAN ID:	
FND: ALL	ELEV: E
PAGE NO: A5.1	

CANE MILL ESTATES LOT 26

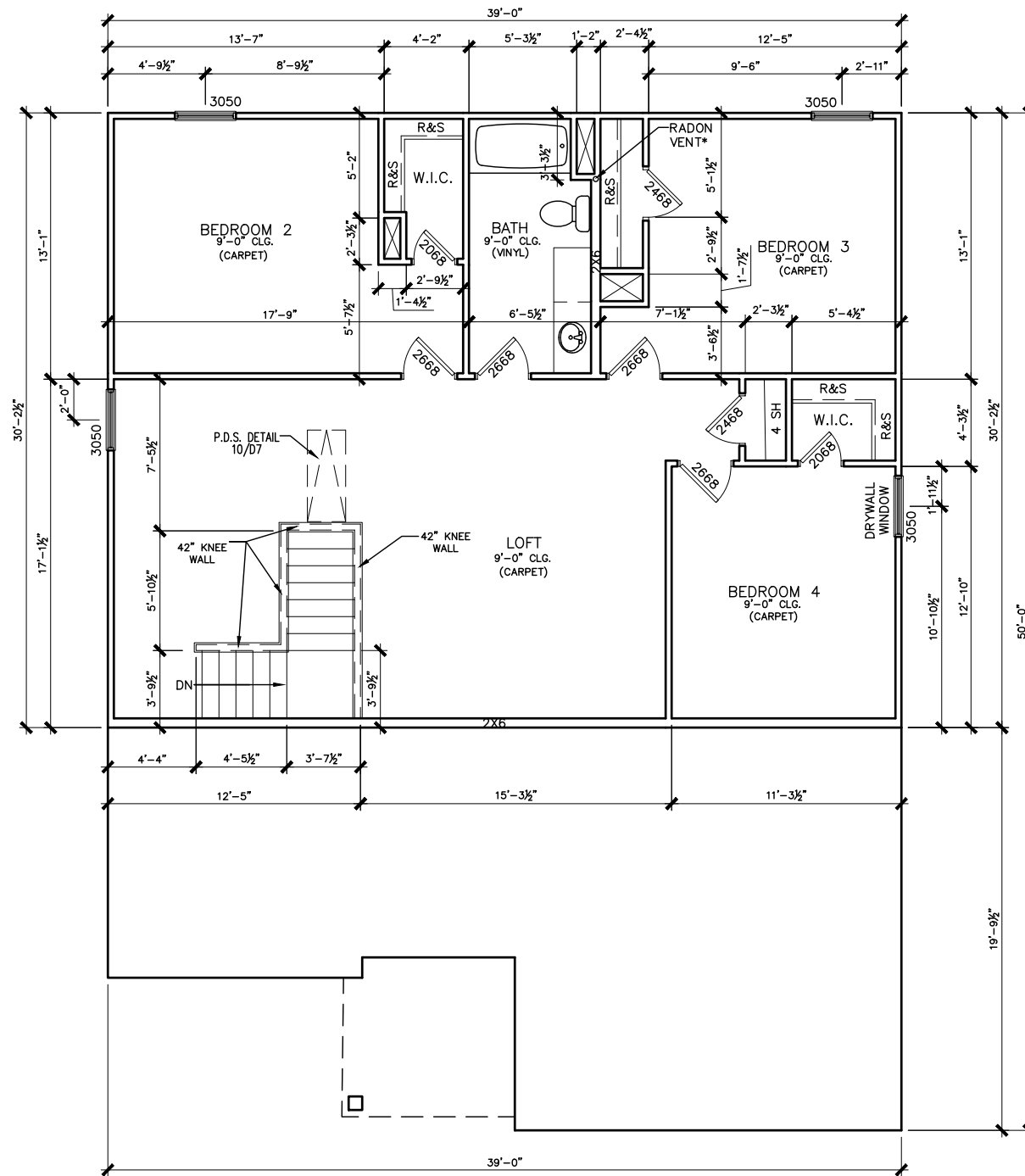

*RADON VENT
PROVIDED PER
LOCAL CODE

SECOND FLOOR PLAN

SCALE: 1/8" = 1'-0"

DATE	REVISION	BY	#



FLOOR PLAN
SECOND FLOOR
REGES

SMITH DOUGLAS HOMES
110 VILLAGE TRAIL
SUITE 115
WOODSTOCK, GA 30188
www.smithdouglas.com

SMITH DOUGLAS HOMES
expressly reserves its
property rights in these
plans and drawings.
These plans and related
drawings are not to be
reproduced without written
consent from SMITH
DOUGLAS HOMES.

BY: ED	CHK: AW
DATE: 5/26/21	
FACADE OPT: B	
PLAN ID:	
FND: ALL	ELEV: E
PAGE NO: A5.2	

CANE MILL ESTATES LOT 26

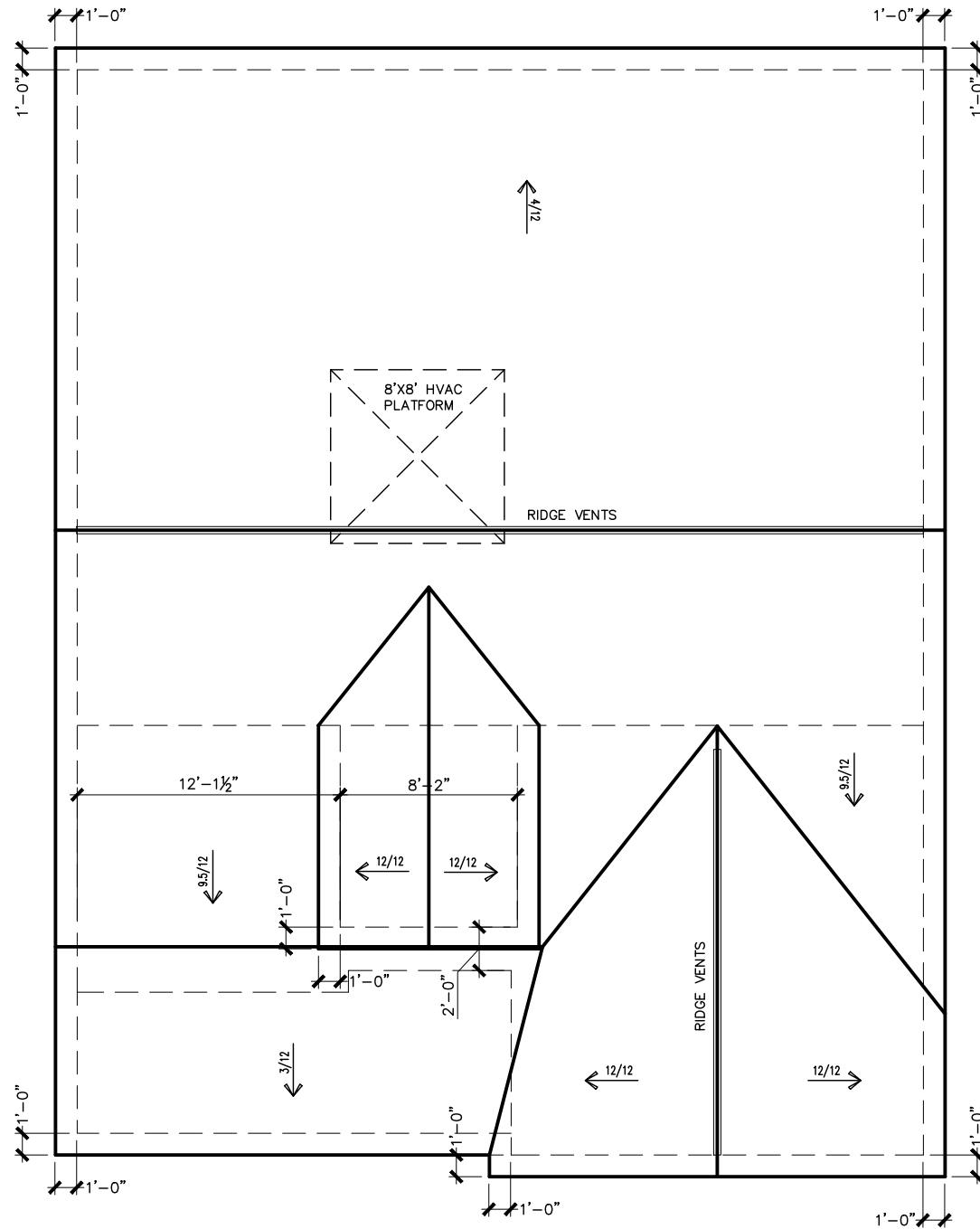

ROOF LAYOUT "E"

SCALE : 1/8" = 1'-0"

DATE	REVISION	BY
#	#	#
#	#	#
#	#	#
#	#	#
#	#	#



ROOF PLAN
ROOF PLAN
REGES

SMITH DOUGLAS HOMES
110 VILLAGE TRAIL
SUITE 115
WOODSTOCK, GA 30188
www.smithdouglas.com

SMITH DOUGLAS HOMES expressly reserves its property rights in these plans and drawings. These plans and related drawings are not to be reproduced without written consent from SMITH DOUGLAS HOMES.

BY: ED	CHK: AW
DATE: 5/26/21	
FACADE OPT: B	
PLAN ID:	
FND: ALL	ELEV: E
PAGE NO: A6.1	

CANE MILL ESTATES LOT 26

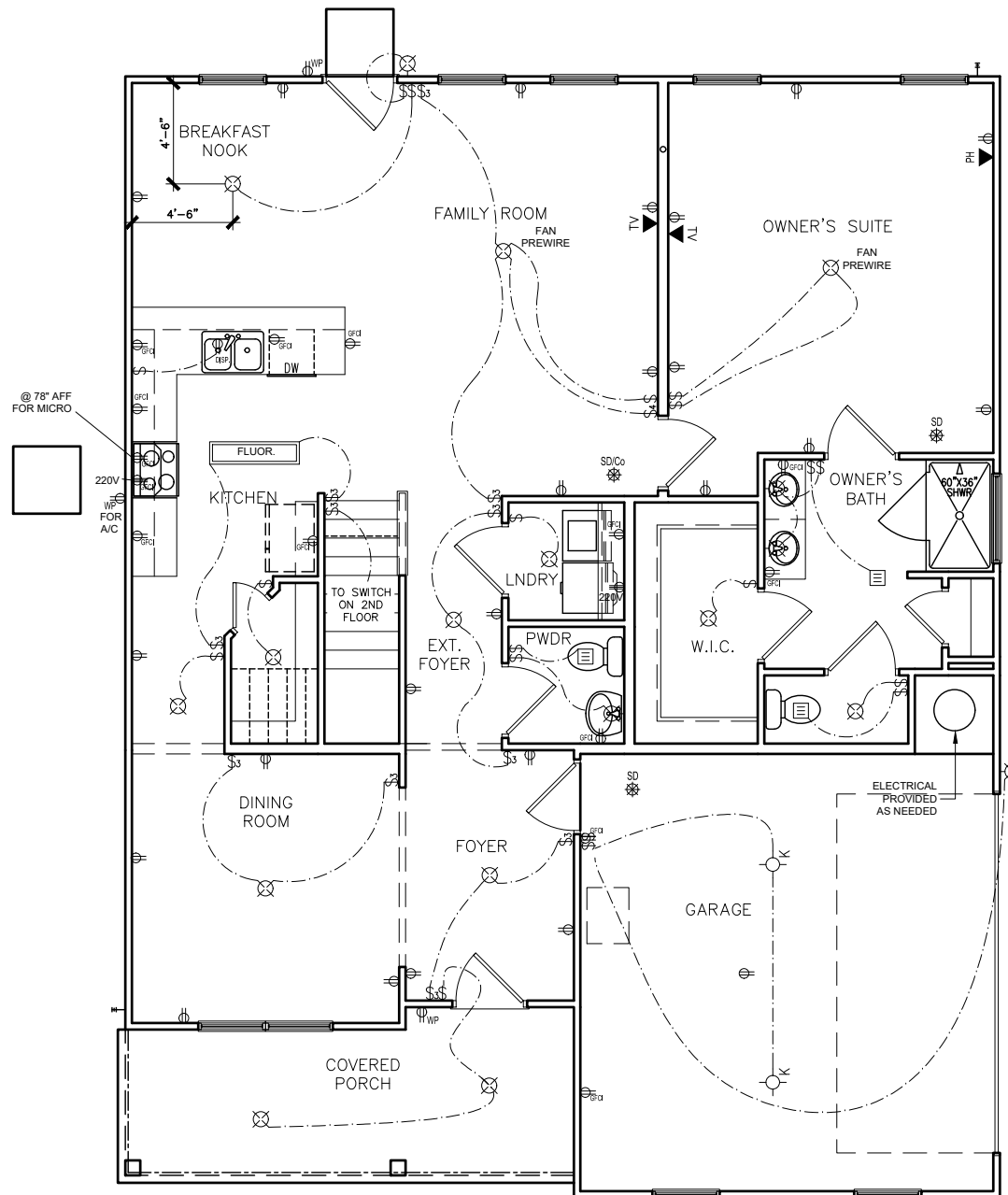

ELECTRICAL LEGEND

\$	SWITCH	TV	TV
\$3	3 WAY SWITCH	⊙	120V RECEPTACLE
\$4	4 WAY SWITCH	⊙	120V SWITCHED RECEPTACLE
⊗	CEILING FIXTURE	⊙	220V RECEPTACLE
⊙	KEYLESS	⊙	GFCI OUTLET
⊗	WALL MOUNT FIXTURE	⊙	ARCH FAULT CIRCUIT INTERRUPTER
⊙	CEILING FIXTURE	†	GAS LINE
●	FLEX CONDUIT	†	WATER LINE
CH	CHIMES	⊥	HOSE BIBB
PH	TELEPHONE	⊙	FLOOD LIGHT
SD/Co	SMOKE DETECTOR & CARBON MONOXIDE	⊙	1x4 LUMINOUS FIXTURE
SO	SECURITY OUTLET	⊗	CEILING FAN
□	GARAGE DOOR OPENER	—	ELECTRICAL WIRING
⊙	EXHAUST FAN	⊙	CEILING FIXTURE
⊙	FAN/LIGHT		

ELECTRICAL PLANS TO FOLLOW ALL LOCAL CODES

APPROX. FIXTURE HGTS (MEASURED FROM BOTTOM OF FIXTURE)

BREAKFAST/DINING ROOM	63" ABOVE FINISHED FLOOR
KITCHEN PENDANT LIGHTS	33" ABOVE COUNTER TOP
TWO STORY FOYER FIXTURE	96" ABOVE FINISHED FLOOR
CEILING FAN	96" ABOVE FINISHED FLOOR

NOTE: FINAL PLACEMENT OF PHONE/CABLE T.B.D. ON SITE BY THE BUILDER

FIRST FLOOR ELECTRICAL PLAN

SCALE: 1/8" = 1'-0"

BY	#	#	#	#	#
REVISION					
DATE					



ELECTRICAL PLAN
FIRST FLOOR
REGES

SMITH DOUGLAS HOMES
110 VILLAGE TRAIL
SUITE 115
WOODSTOCK, GA 30188
www.smithdouglas.com

SMITH DOUGLAS HOMES expressly reserves it's property rights in these plans and drawings. These plans and related drawings are not to be reproduced without written consent from SMITH DOUGLAS HOMES.

BY: ED	CHK: AW
DATE: 5/26/21	
FACADE OPT: B	
PLAN ID:	
FND: ALL	ELEV: E
PAGE NO: A7.2	

CANE MILL ESTATES LOT 26

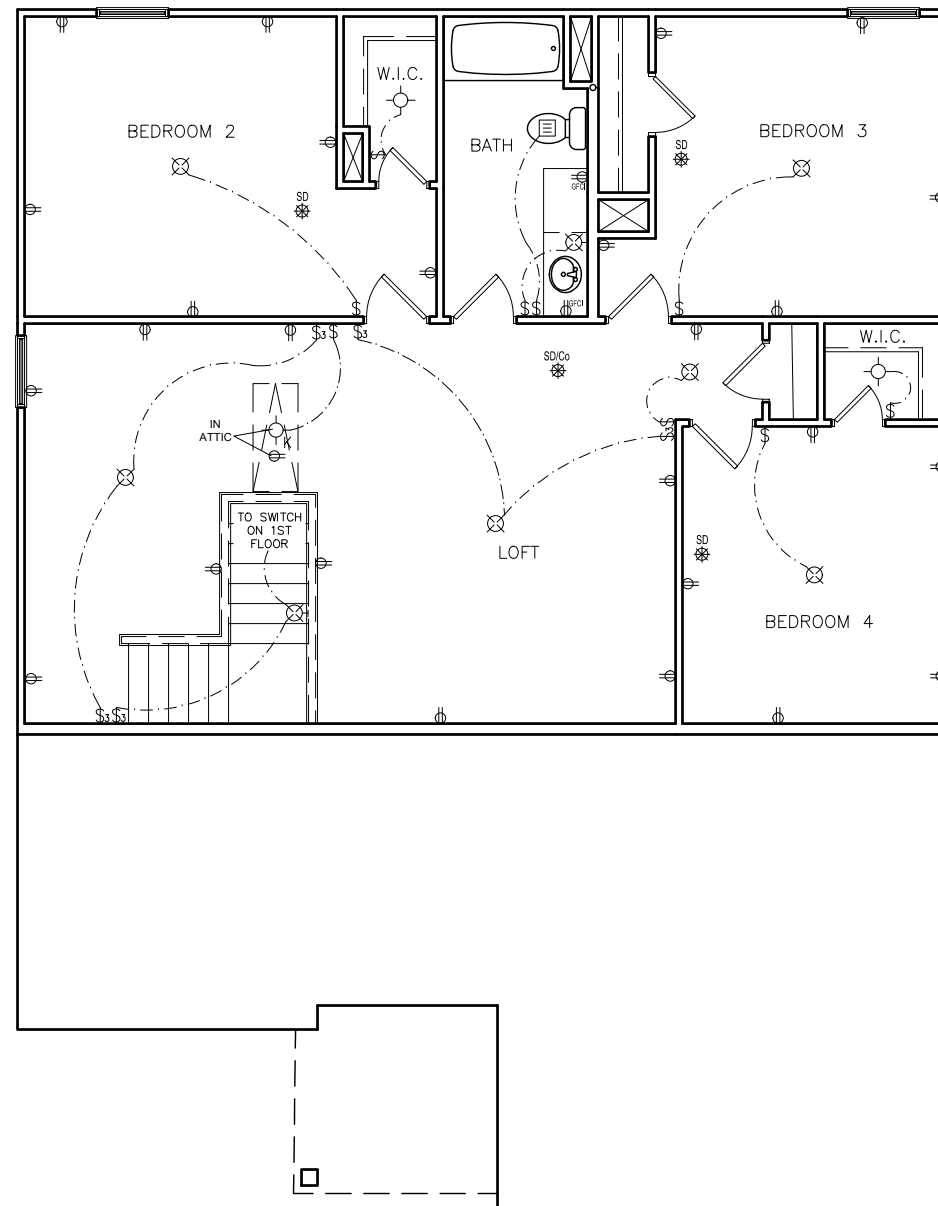

SECOND FLOOR ELECTRICAL PLAN

SCALE: 1/8" = 1'-0"

ELECTRICAL LEGEND

\$	SWITCH	TV	TV
\$3	3 WAY SWITCH	⊕	120V RECEPTACLE
\$4	4 WAY SWITCH	⊕	120V SWITCHED RECEPTACLE
⊗	CEILING FIXTURE	⊕	220V RECEPTACLE
⊕	KEYLESS	⊕	GFCI
⊕	WALL MOUNT FIXTURE	⊕	AFCI
⊕	CEILING FIXTURE	†	GL
●	FLEX CONDUIT	†	WL
CH	CHIMES	⊥	HOSE BIBB
PH	TELEPHONE	⊕	FLOOD LIGHT
SD/Co	SMOKE DETECTOR & CARBON MONOXIDE	⊕	1x4 LUMINOUS FIXTURE
SO	SECURITY OUTLET	⊕	CEILING FAN
□	GARAGE DOOR OPENER	—	ELECTRICAL WIRING
⊕	EXHAUST FAN	⊕	CEILING FIXTURE
⊕	FAN/LIGHT		

ELECTRICAL PLANS TO FOLLOW ALL LOCAL CODES

APPROX. FIXTURE HGTS (MEASURED FROM BOTTOM OF FIXTURE)

BREAKFAST/DINING ROOM	63" ABOVE FINISHED FLOOR
KITCHEN PENDANT LIGHTS	33" ABOVE COUNTER TOP
TWO STORY FOYER FIXTURE	96" ABOVE FINISHED FLOOR
CEILING FAN	96" ABOVE FINISHED FLOOR

NOTE: FINAL PLACEMENT OF PHONE/CABLE T.B.D. ON SITE BY THE BUILDER

BY	#	REVISION	DATE



ELECTRICAL PLAN
SECOND FLOOR
REGES

SMITH DOUGLAS HOMES
110 VILLAGE TRAIL
SUITE 115
WOODSTOCK, GA 30188
www.smithdouglas.com

SMITH DOUGLAS HOMES expressly reserves its property rights in these plans and drawings. These plans and related drawings are not to be reproduced without written consent from SMITH DOUGLAS HOMES.

BY: ED	CHK: AW
DATE: 5/26/21	
FACADE OPT: B	
PLAN ID:	
FND: ALL	ELEV: E
PAGE NO: A7.3	

CANE MILL ESTATES LOT 26

Lot Definition

Project: Cane Mill Estates		Community: Cane Mill Estates	
Building: 000		Builder: Thomas Kenneth Barlow	
Unit: 0026		Status: Sold	
Plan: Reges E Side Entry		RTeam: Raleigh West	
Orientation: Garage Right	Sq. Ft: 2,532	Slot: 5510	
Bedrooms: 4	Bathrooms: 2.5	Permit:	
Address: 82 Trolley Lane		Notes:	
Coats			
NC 27521			

Sales Data	Dates
Contract: 89634	Rectified: 04/13/2021
Buyer: Marilu Lopez	Original Start: 05/21/2021
Sales Agent: Nicole Stinard	Start: 05/21/2021
	Scheduled Complete: 09/30/2021

Option	Description	Quantity
36" Cabinet (0) Standard	Note: Bath cabinets to match	1
Chrome Interior Finish Color Package	Includes chrome kitchen faucet, bath faucets, & fixtures, brushed nickel door hardware (knobs, bumps, knobset/levers, deadbolts), Pkg1 (bn) lighting fixtures, & pewter oval mirror. Separate options also affected: shower door, bath hardware (bowl hairring, tp holder), shower grab bar, cabinet hardware	1
FPkg 5AA-Floorte Pro, StdCpt (FPkg1)	Flooring Package 5AA - Floorte Pro, Standard Carpet (from Package 1). SPC (solid polymer core) 0.5 mm vinyl top layer plank	1
Granite-Kitchen Countertops - Lvl 1 (0)	Kitchen Granite Countertops - Level 1-where Lamante is Std.	1
Owner Bath Marble 1 Double ilo LamSgl	***Includes Vanity Double Bowl Option Do Not Select Bath***	1
Stone 19 A ExtColPkg(f)		1

User Name: Kerry DeCarlo 1 of 2 05/19/2021
Database: SmithDouglasCommunities 09:35:57 AM

Lot Definition

Activity	Description	Selection Description
Del&Install AppliancePkg	Appliance Package Select - All	Appliance Package Selected
Install Cabinets Complet	Cabinet Finish - Standard Aris	Standard-Sinclair Birch- Saddle
Install Cabinets Complet	Secondary Bath Vanity Tops-All	4550-01 Granite
Install Carpet	Carpet - Standard ALL	Smith Grove II Trade Wind 00502
Install Floorte Pro (LP)	Floorte Pro 1stUpgr ALL	Presto Plus - 709 Modeled Oak
Install Granite Tops	RDU Granite CounterKitchenLvl1	Dallie-Crema Caramel
Install Marble Tops	RDU Marble Vanity Top Lvl 1	Matte-#153 White w/ice Grey w/oval bowl
Paint Interior Complete	Interior Paint (Trim)	SW 7006 Extra White
Paint Interior Complete	Interior Paint (Walls) - Base	SW 6105 Divine White
PM Install Vinyl Floor	VinylPkg-Option Baths	Highlands II Shadow Grey 557
PM Install Vinyl Floor	VinylPkg-Owner Bath	Highlands II Shadow Grey 557
PM Install Vinyl Floor	VinylPkg-Std 2nd Baths/Laundry	Highlands II Shadow Grey 557

User Name: Kerry DeCarlo 2 of 2 05/19/2021
Database: SmithDouglasCommunities 09:35:57 AM

BY	REVISION	#	#	#	#	#
#	#	#	#	#	#	#



DETAILS
 LOT DEFINITION
 REGES

SMITH DOUGLAS HOMES
 110 VILLAGE TRAIL
 SUITE 115
 WOODSTOCK, GA 30188
 www.smithdouglas.com

SMITH DOUGLAS HOMES expressly reserves it's property rights in these plans and drawings. These plans and related drawings are not to be reproduced without written consent from SMITH DOUGLAS HOMES.

BY: ED	CHK: AW
DATE: 5/26/21	
FACADE OPT: B	
PLAN ID:	
FND: ALL	ELEV: E
PAGE NO: A9.1	

GENERAL STRUCTURAL NOTES:

- The design professional whose seal appears on these drawings is the structural engineer of record (SER) for this project. The SER bears the responsibility of the primary structural elements and the performance of this structure. No other party may revise, alter, or delete any structural aspects of these construction documents without written permission of SUMMIT Engineering, Laboratory & Testing, P.C. (SUMMIT) or the SER. For the purposes of these construction documents the SER and SUMMIT shall be considered the same entity.
The structure is only stable in its completed form. The contractor shall provide all required temporary bracing during construction to stabilize the structure.
- The SER is not responsible for construction sequences, methods, or techniques in connection with the construction of this structure. The SER will not be held responsible for the contractor's failure to conform to the contract documents, should any non-conformities occur.
- Any structural elements or details not fully developed on the construction drawings shall be completed under the direction of a licensed professional engineer. These shop drawings shall be submitted to SUMMIT for review before any construction begins. The shop drawings will be reviewed for overall compliance as it relates to the structural design of this project. Verification of the shop drawings for dimensions, or for actual field conditions, is not the responsibility of the SER or SUMMIT.
- Verification of assumed field conditions is not the responsibility of the SER. The contractor shall verify the field conditions for accuracy and report any discrepancies to SUMMIT before construction begins.
- The SER is not responsible for any secondary structural elements or non-structural elements, except for the elements specifically noted on the structural drawings.
- This structure and all construction shall conform to all applicable sections of the International Residential Code.
- This structure and all construction shall conform to all applicable sections of local building codes.
- All structural assemblies are to meet or exceed to requirements of the current local building code.

FOUNDATIONS:

- The structural engineer has not performed a subsurface investigation. Verification of this assumed value is the responsibility of the owner or the contractor. Should any adverse soil condition be encountered the SER must be contacted before proceeding.
- The bottom of all footings shall extend below the frost line for the region in which the structure is to be constructed. However, the bottom of all footings shall be a minimum of 12" below grade.
- Any fill shall be placed under the direction or recommendation of a licensed professional engineer.
- The resulting soil shall be compacted to a minimum of 95% maximum dry density.
- Excavations of footings shall be lined temporarily with a 6 mil polyethylene membrane if placement of concrete does not occur within 24 hours of excavation.
- No concrete shall be placed against any subgrade containing water, ice, frost, or loose material.

STRUCTURAL STEEL:

- Structural steel shall be fabricated and erected in accordance with the American Institute of Steel Construction "Code of Standard Practice for Steel Buildings and Bridges" and the manual of Steel Construction "Load Resistance Factor Design" latest editions.
- Structural steel shall receive one coat of shop applied rust-inhibitive paint.
- All steel shall have a minimum yield stress (F_y) of 36 ksi unless otherwise noted.
- Welding shall conform to the latest edition of the American Welding Society's Structural Welding Code AWS D11. Electrodes for shop and field welding shall be class E70XX. All welding shall be performed by a certified welder per the above standards.

CONCRETE:

- Concrete shall have a normal weight aggregate and a minimum compressive strength (f_c) at 28 days of 3000 psi, unless otherwise noted on the plan.
- Concrete shall be proportioned, mixed, and placed in accordance with the latest editions of ACI 318: "Building Code Requirements for Reinforced Concrete" and ACI 301: "Specifications for Structural Concrete for Buildings".
- Air entrained concrete must be used for all structural elements exposed to freeze/thaw cycles and deicing chemicals. Air entrainment amounts (in percent) shall be within -1% to +2% of target values as follows:
31. Footings: 5%
32. Exterior Slabs: 5%
- No admixtures shall be added to any structural concrete without written permission of the SER.
- Concrete slabs-on-grade shall be constructed in accordance with ACI 302.1R-96: "Guide for Concrete Slab and Slab Construction".
- The concrete slab-on-grade has been designed using a subgrade modulus of $k=250$ pci and a design loading of 200 psi. The SER is not responsible for differential settlement, slab cracking or other future defects resulting from unreported conditions not in accordance with the above assumptions.
- Control or saw cut joints shall be spaced in interior slabs-on-grade at a maximum of 15'-0" O.C. and in exterior slabs-on-grade at a maximum of 10'-0" unless otherwise noted.
- Control or saw cut joints shall be produced using conventional process within 4 to 12 hours after the slab has been finished.
- Reinforcing steel may not extend through a control joint.
- Reinforcing steel may extend through a saw cut joint.
- All welded wire fabric (WUJF) for concrete slabs-on-grade shall be placed at mid-depth of slab. The WUJF shall be securely supported during the concrete pour.

CONCRETE REINFORCEMENT:

- Fibrous concrete reinforcement, or fibermesh, specified in concrete slabs-on-grade may be used for control of cracking due to shrinkage and thermal expansion/contraction, lowered water migration, an increase in impact capacity, increased abrasion resistance, and residual strength.
- Fibermesh reinforcing to be 100% virgin polypropylene fibers containing no reprocessed olefin materials and specifically manufactured for use as concrete secondary reinforcement.
- Application of fibermesh per cubic yard of concrete shall equal a minimum of 0.1% by volume (15 pounds per cubic yard).
- Fibermesh shall comply with ASTM C116, any local building code requirements, and shall meet or exceed the current industry standard.
- Steel reinforcing bars shall be new billet steel conforming to ASTM A615, grade 60.
- Detailing, fabrication, and placement of reinforcing steel shall be in accordance with the latest edition of ACI 315: "Manual of Standard Practice for Detailing Concrete Structures".
- Horizontal footing and wall reinforcement shall be continuous and shall have 90° bends, or corner bars with the same size/spacing as the horizontal reinforcement with a class B tension splice.
- Lap reinforcement as required, a minimum of 40 bar diameters for tension or compression unless otherwise noted. Splices in masonry shall be a minimum of 48 bar diameters.
- Where reinforcing dowels are required, they shall be equivalent in size and spacing to the vertical reinforcement. The dowel shall extend 48 bar diameters vertically and 20 bar diameters into the footing.
- Where reinforcing steel is required vertically, dowels shall be provided unless otherwise noted.

WOOD FRAMING:

- Solid sawn wood framing members shall conform to the specifications listed in the latest edition of the "National Design Specification for Wood Construction" (NDS). Unless otherwise noted, all wood framing members are designed to be Southern-Yellow-Pine (SYP) #2.
- LVL or PSL engineered wood shall have the following minimum design values:
2.1. $E = 1900000$ psi
2.2. $F_b = 2600$ psi
2.3. $F_v = 285$ psi
2.4. $F_c = 100$ psi
- Wood in contact with concrete, masonry, or earth shall be pressure treated in accordance with AIA/PA standard C-15. All other moisture exposed wood shall be treated in accordance with AIA/PA standard C-2
- Nails shall be common wire nails unless otherwise noted.
- Lag screws shall conform to ANSI/AYIE standard B182.1-1981. Lead holes for lag screws shall be in accordance with NDS specifications.
- All beams shall have full bearing on supporting framing members unless otherwise noted.
- Exterior and load bearing stud walls are to be 2x4 SYP #2 @ 16" O.C. unless otherwise noted. Studs shall be continuous from the sole plate to the double top plates. Studs shall only be discontinuous at headers for window/door openings. A minimum of one king stud shall be placed at each end of the header. King studs shall be continuous.
- Individual studs forming a column shall be attached with one 10d nail @ 6" O.C. staggered. The stud column shall be continuous to the foundation or beam. The column shall be properly blocked at all floor levels to ensure proper load transfer.
- Multi-ply beams shall have each ply attached with (3) 10d nails @ 24" O.C.
- Four and five ply beams shall be bolted together with (2) rows of 1/2" diameter through bolts staggered @ 16" O.C. unless noted otherwise.

WOOD TRUSSES:

- The wood truss manufacturer/fabricator is responsible for the design of the wood trusses. Submit sealed shop drawings and supporting calculations to the SER for review prior to fabrication. The SER shall have a minimum of five (5) days for review. The review by the SER shall review for overall compliance with the design documents. The SER shall assume no responsibility for the correctness for the structural design for the wood trusses.
- The wood trusses shall be designed for all required loadings as specified in the local building code, the ASCE Standard "Minimum Design Loads for Buildings and Other Structures." (ASCE 7-10) and the loading requirements shown on these specifications. The truss drawings shall be coordinated with all other construction documents and provisions provided for loads shown on these drawings including but not limited to HVAC equipment, piping, and architectural fixtures attached to the trusses.
- The trusses shall be designed, fabricated, and erected in accordance with the latest edition of the "National Design Specification for Wood Construction" (NDS) and "Design Specification for Metal Plate Connected Wood Trusses." (ASCE 7-10).
- The truss manufacturer shall provide adequate bracing information in accordance with "Commentary and Recommendations for Handling, Installing, and Bracing Metal Plate Connected Wood Trusses" (HLB-9). This bracing, both temporary and permanent, shall be shown on the shop drawings. Also, the shop drawings shall show the required attachments for the trusses.
- Any chords or truss webs shown on these drawings have been shown as a reference only. The final design of the trusses shall be per the manufacturer.

EXTERIOR WOOD FRAMED DECKS:

- Decks are to be framed in accordance with local building codes and as referenced on the structural plans, either through code references or construction details.

WOOD STRUCTURAL PANELS:

- Fabrication and placement of structural wood sheathing shall be in accordance with the APA Design/Construction Guide "Residential and Commercial", and all other applicable APA standards. All structurally required wood sheathing shall bear the mark of the APA.
- Wood wall sheathing shall comply with the requirements of local building codes for the appropriate state as indicated on these drawings. Refer to wall bracing notes in plan set for more information. Sheathing shall be applied with the long direction perpendicular to framing, unless noted otherwise.
- Roof sheathing shall be APA rated sheathing exposure 1 or 2. Roof sheathing shall be continuous over two supports and attached to its supporting roof framing with (1)-8d CC nail at 6" o/c at panel edges and at 12" o/c in panel field unless otherwise noted on the plans. Sheathing shall be applied with the long direction perpendicular to framing. Sheathing shall have a span rating consistent with the framing spacing. Use suitable edge support by use of plywood clips or lumber blocking unless otherwise noted. Panel end joints shall occur over framing. Apply building paper over the sheathing as required by the state Building Code.
- Wood floor sheathing shall be APA rated sheathing exposure 1 or 2. Attach sheathing to its supporting framing with (1)-8d CC ringshank nail at 6" o/c at panel edges and at 12" o/c in panel field unless otherwise noted on the plans. Sheathing shall be applied perpendicular to framing. Sheathing shall have a span rating consistent with the framing spacing. Use suitable edge support by use of T&G plywood or lumber blocking unless otherwise noted. Panel end joints shall occur over framing. Apply building paper over the sheathing as required by the state Building Code.
- Sheathing shall have a 1/8" gap at panel ends and edges as recommended in accordance with the APA.

STRUCTURAL FIBERBOARD PANELS:

- Fabrication and placement of structural fiberboard sheathing shall be in accordance with the applicable AFA standards.
- All structurally required fiberboard sheathing shall bear the mark of the AFA.
- Fiberboard wall sheathing shall comply with the requirements of local building codes for the appropriate state as indicated on these drawings. Refer to wall bracing notes in plan set for more information.
- Sheathing shall have a 1/8" gap at panel ends and edges as recommended in accordance with the AFA.

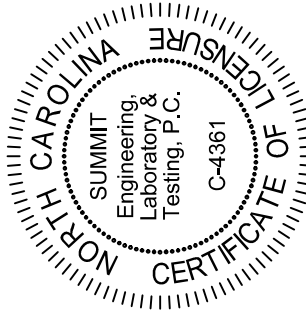

PROJECT: 2520 Reliance Ave. Raleigh, NC 27539
COVER SHEET
DATE: 6/26/20
SCALE: 1/8"=1'-0"
PROJECT #: 3832.350
DRAWN BY: LBV
CHECKED BY: LAG

DRAWING

DATE: 6/26/20
SCALE: 1/8"=1'-0"
PROJECT #: 3832.350
DRAWN BY: LBV
CHECKED BY: LAG

ORIGINAL INFORMATION
PROJECT #: 3832.146
DATE: 6/25/2018

REFER TO COVER SHEET FOR A COMPLETE LIST OF REVISIONS

SHEET

CS2

Cane Mill
Lot 26

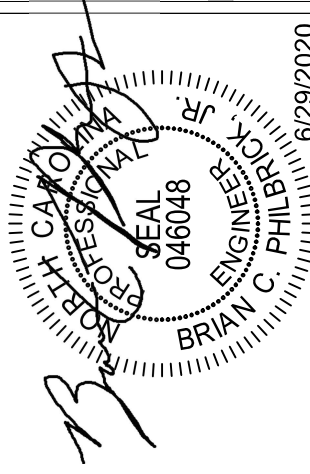

6/29/2020

STRUCTURAL MEMBERS ONLY

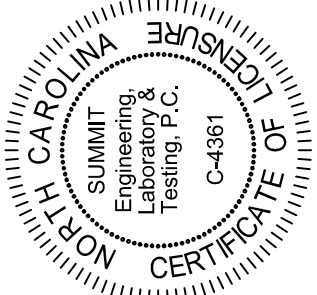

PROJECT: Reges #1
FIRST Floor Framing
CLIENT: Smith Douglas Homes - Raleigh
2520 Reliance Ave.
Apex, NC 27539

DRAWING DATE: 6/26/20
SCALE: 1/8"=1'-0"
PROJECT #: 3832.350
DRAIN BY: LBV
CHECKED BY: LAG

ORIGINAL INFORMATION
PROJECT #: 3832.146
DATE: 6/25/2018
REFER TO COVER SHEET FOR A COMPLETE LIST OF REVISIONS

SHEET
S3.1

SEE SHEET S3.0 FOR NOTES AND MORE INFORMATION

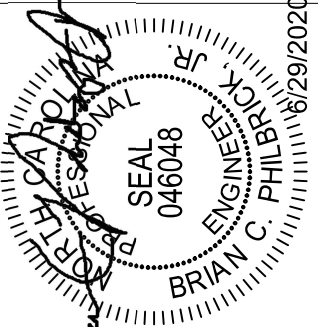
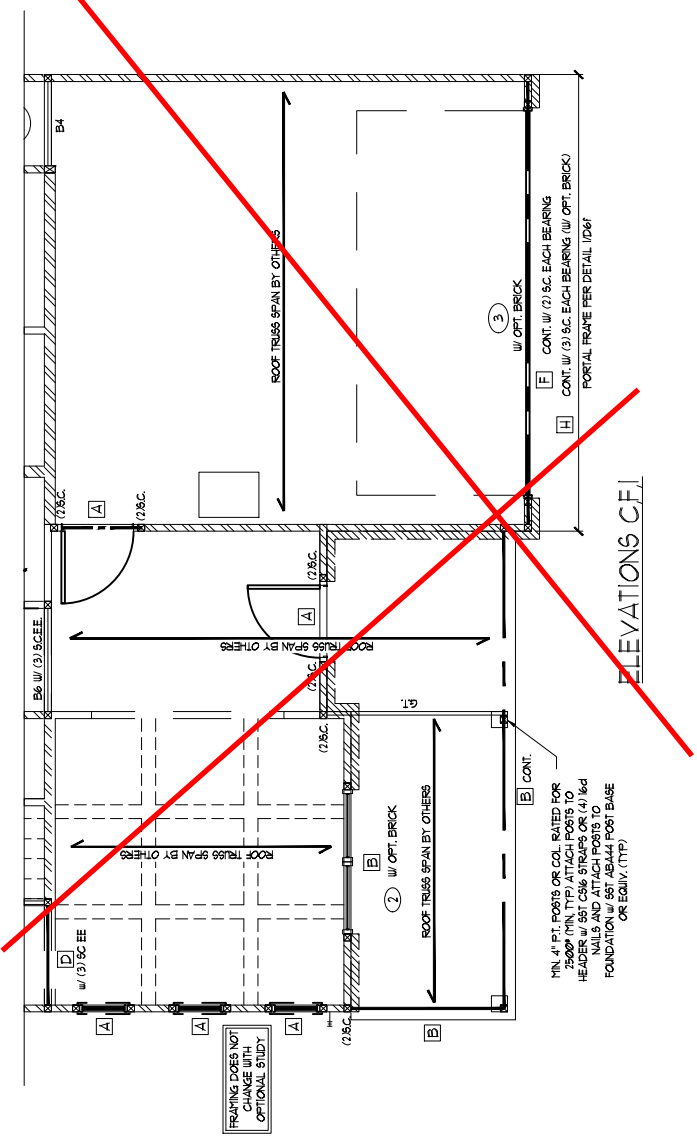
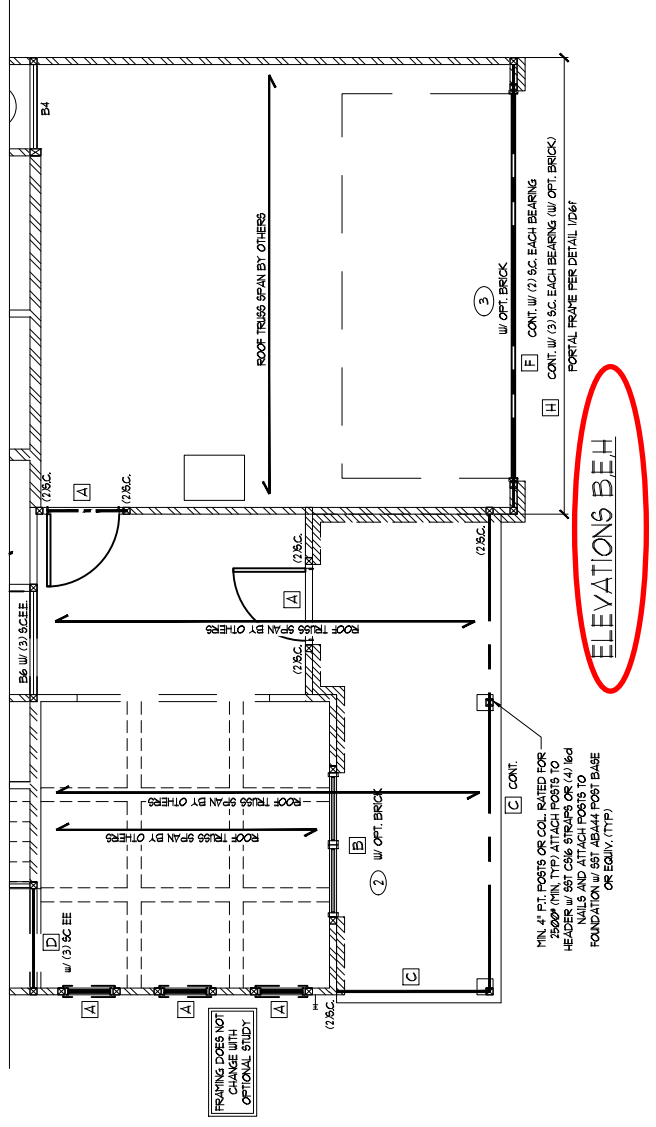

Cane Mill
Lot 26

STRUCTURAL MEMBERS ONLY

STRUCTURAL ANALYSIS BASED ON 2018 NCRS.
ENGINEERING SEAL APPLIES ONLY TO STRUCTURAL COMPONENTS ON THIS DOCUMENT. SEAL DOES NOT INCLUDE CONSTRUCTION MEANS, METHODS, TECHNIQUES, SEQUENCES PROCEDURES OR SAFETY PRECAUTIONS. ENGINEER'S DESIGNATION DOES NOT IMPLY TO BE BOUND TO THE DOCUMENT'S CONTENTS OR TO BE HELD RESPONSIBLE FOR ANY FAILURE OF THE STRUCTURE TO DO SO WILL VOID SUMMIT LIABILITY.

STRUCTURAL MEMBERS ONLY
FIRST FLOOR FRAMING PLAN
SCALE: 1/8"=1'

HEADER/BEAM SCHEDULE		
HEADER TAG	BEAM TAG	SIZE
-	B1	(1) 14" FLOOR JOIST
-	B2	(2) 14" FLOOR JOISTS
A	B3	(2) 2x6
B	B4	(2) 2x6
C	B5	(2) 2x6
D	B6	(2) 2x6
E	B7	(2) 9-1/4" L.S.L./L.V.L.
F	B8	(2) 11-1/8" L.S.L./L.V.L.
G	B9	(2) 14" L.S.L./L.V.L.
H	B10	(2) 16" L.V.L.
I	B11	(2) 18" L.V.L.
J	B12	(2) 24" L.V.L.
K	B13	(3) 9-1/4" L.S.L./L.V.L.
L	B14	(3) 11-1/8" L.S.L./L.V.L.
M	B15	(3) 14" L.S.L./L.V.L.
N	B16	(3) 16" L.V.L.
O	B18	(3) 18" L.V.L.
P	B19	(3) 24" L.V.L.

NOTES:
 1. BEAM SPAN ON PLANS ARE MINIMUMS. GREATER SIZES MAY BE USED FOR EASE OF CONSTRUCTION.
 2. ALL HEADERS TO BE DROPPED (UNO).
 3. STD. COLUMNS NOTED ON PLAN OVERLAP STD. COLUMNS LISTED ABOVE (UNO).

KING STUD SCHEDULE		
MAXIMUM HEADER SPAN	MINIMUM KING STUDS E.E.	
3'-0"	(1)	
4'-0"	(2)	
8'-0"	(3)	
11'-0"	(5)	
16'-0"	(6)	

WALL STUD SCHEDULE (Ø FT HEIGHT)				
STUD SIZE	STUD SPACING (O.C.)	ROOF & FLOOR	ROOF & NON-LOAD BEARING	NON-LOAD BEARING
2x4	24"	16"	12"	24"
2x6	24"	24"	18"	24"

NOTES:
 1. BRICKED WALLS SHALL BE A MAX. OF 16" O.C.
 2. STUDS SUPPORTS OPTIONAL WALK-UP ATTIC SHALL BE SPACED A MAX. OF 16" O.C.
 3. TWO STORY WALLS SHALL BE REINFORCED WITH 2x4 STUDS @ 12" O.C. VERTICALLY.
 4. HORIZONTAL BLOCKING @ 6'-0" O.C. VERTICALLY.

LINTEL SCHEDULE	
TAG	OPENING SIZE
①	13x31/4"
②	13x31/4"
③	13x3-1/2x51/8"
④	13x3-1/2x51/8"

NOTES:
 1. SECURE LINTEL TO HEADER W/ (2) 1/2" DIAMETER LAG BOLTS STAGGERED AT 16" O.C. (TOP FOR OPENINGS GREATER THAN 6'-0").
 2. ALL HEADERS WHERE BRICK IS PRESENT, TO BE (U)NO.
 SHADOWED WALLS INDICATED LOAD BEARING WALLS

NOTE: FLOOR JOISTS SHALL BE DESIGNED TO SUPPORT ADDITIONAL LOAD UNDER TILE FLOORS, GRANITE COUNTERTOPS AND/OR ISLANDS.

THESE PLANS ARE DESIGNED IN ACCORDANCE WITH ARCHITECTURAL PLANS PROVIDED BY SMITH DOUGLAS HOMES. COMPLETED/REVISED ON 6/27/20. IT IS THE RESPONSIBILITY OF THE ARCHITECT TO VERIFY ALL DIMENSIONS AND MATERIALS. ANY CHANGES ARE MADE TO THE ARCHITECTURAL PLANS PRIOR TO CONSTRUCTION. SUBMITTEE CANNOT GUARANTEE THE ACCURACY OF THESE STRUCTURAL PLANS WHEN USED WITH ARCHITECTURAL PLANS DATED DIFFERENTLY THAN THE DATE LISTED ABOVE.

STRUCTURAL MEMBERS ONLY

ENGINEERING SEAL APPLIES ONLY TO STRUCTURAL COMPONENTS ON THIS DOCUMENT. SEAL DOES NOT INCLUDE CONSTRUCTION MEANS, METHODS, TECHNIQUES, SEQUENCES, PROCEDURES OR SAFETY PRECAUTIONS. TO VERIFY ALL DIMENSIONS AND MATERIALS, REFER TO ARCHITECTURAL PLANS PROVIDED TO THE ARCHITECTURE. SUBMITTEE CANNOT BE HELD RESPONSIBLE FOR ANY CONSTRUCTION DEFICIENCIES, ENGINEERING, LABORATORY TESTING, P.C. FAILURE TO DO SO WILL VOID SUMMIT LIABILITY.

STRUCTURAL ANALYSIS BASED ON 2018 NCRC.

SECOND FLOOR FRAMING PLAN

SCALE: 1/8"=1'

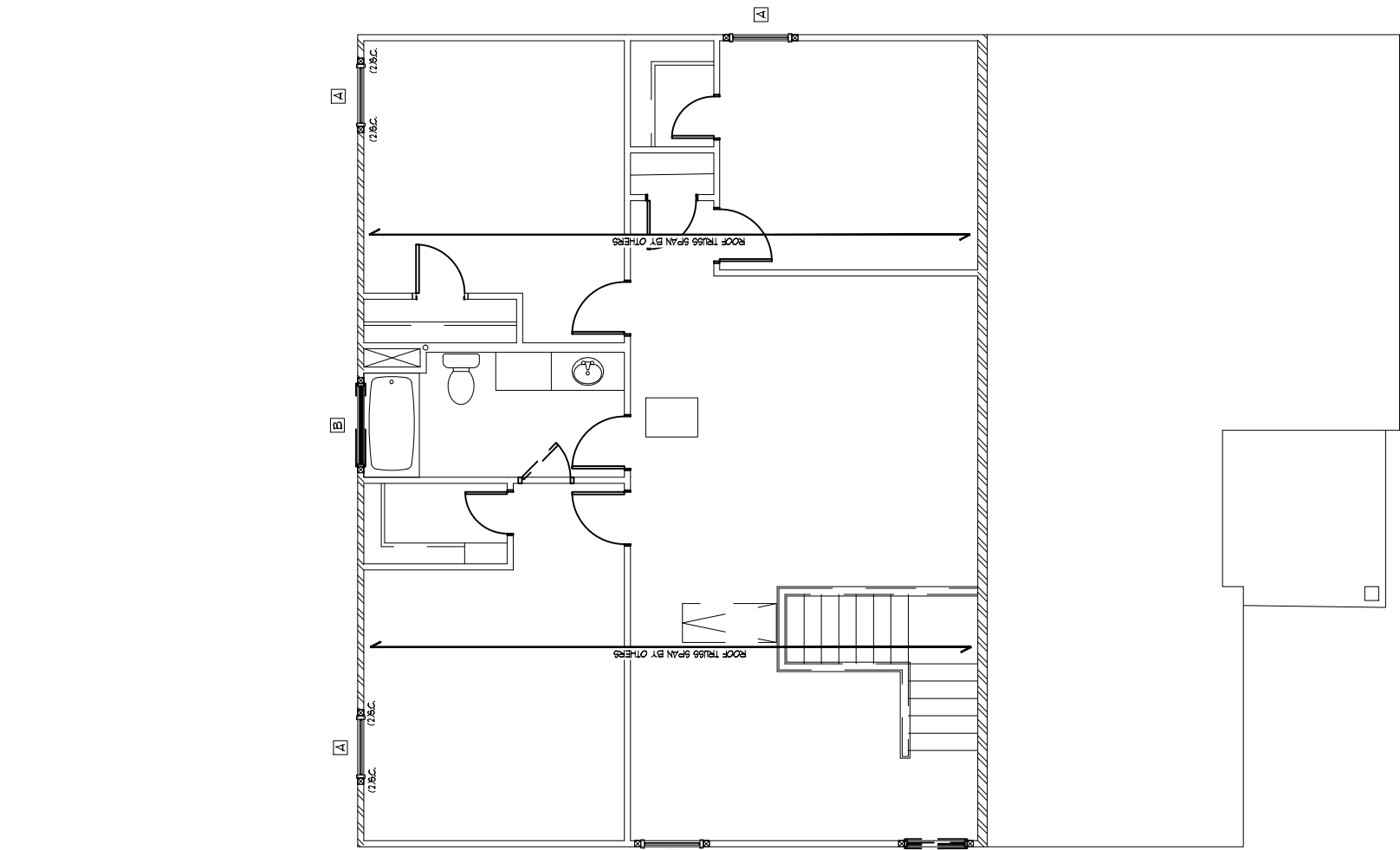

ALL ELEVATIONS

Cane Mill
Lot 26

STRUCTURAL MEMBERS ONLY

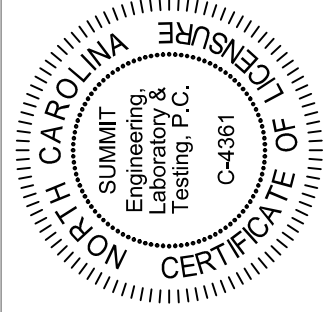

PROJECT: Reg 971
 Second Floor Framing
 CLIENT: Smith Douglas Homes - Raleigh
 2520 Reliance Ave.
 Apex, NC 27539

DRAWING DATE: 6/26/20
 SCALE: 1/8"=1'-0"
 PROJECT #: 3832.350
 DRAIN BY: LBV
 CHECKED BY: LAG

ORIGINAL INFORMATION
 PROJECT #: 3832.146 DATE: 6/25/2018
 REFER TO COVER SHEET FOR A COMPLETE LIST OF REVISIONS

9 SHEET
S4.0

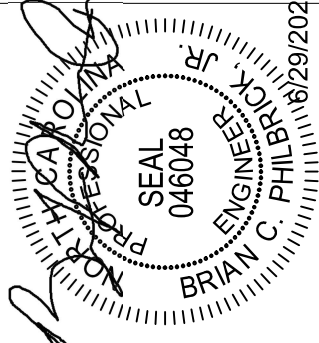

TRUSS UPLIFT CONNECTOR SCHEDULE			
MAX. UPLIFT	ROOF TO WALL	FLOOR TO FLOOR	FLOOR TO RD
600 LBS	H2A	PER WALL SHEATHING & FASTENERS	
1000 LBS	(2) H2A	C546 (END • 1')	DTTZ
1400 LBS	HT500	C546 (END • 1')	DTTZ
2000 LBS	(1) HT500	(1) C546 (END • 1')	DTTZ
2500 LBS	(2) HT500	(2) C546 (END • 1')	HT4
3600 LBS	L673-50/515	H91C2	HT4

- ALL PRODUCTS LISTED ARE SIMPSON STRONG-TIE EQUIVALENT PRODUCTS MAY BE USED PER MANUFACTURER'S SPECIFICATIONS.
- UPLIFT VALUES LISTED ARE FOR S1P # GRADE MEMBERS AND INCLUDE SHEATHING AND FASTENERS. REFER TO THE MANUFACTURER'S LITERATURE FOR WALLING REQUIREMENTS FOR THE CONNECTED TRUSS TO TOP PLATE CONNECTIONS.
- REFER TO TRUSS LAYOUT PER MANUFACTURER FOR UPLIFT VALUES AND TRUSS TO TRUSS CONNECTIONS. CONNECTIONS SPECIFIED BY TRUSS MANUFACTURER OVERRIDE THOSE LISTED ABOVE.
- ALL TRUSS CONNECTIONS SHALL BE VERIFIED BY AN INDEPENDENT ENGINEER. ALL TRUSS REQUIREMENTS SHALL BE VERIFIED BY AN INDEPENDENT ENGINEER. CONTACT SUMPIT FOR REQUIRED CONNECTORS WHEN LOADS EXCEED THOSE LISTED ABOVE.

NOTE: 18" FLY OF ALL SHOWN GIRDERS TRUSSES TO ALIGN WITH INSIDE FACE OF WALL (TYP. UNO)

NOTE: ROOF TRUSSES SHALL BE SPACED TO SUPPORT FALSE FRAMED DORMER WALLS (TYP. UNO)

NOTE: TRUSS UPLIFT LOADS SHALL BE DETERMINED PER TRUSS MANUFACTURER IN ACCORDANCE WITH SECTION 906.0111 WALL SHEATHING AND FASTENERS HAVE BEEN DESIGNED TO RESIST THE WIND UPLIFT LOAD PATH IN ACCORDANCE WITH METHOD 3 OF SECTION 906.0135 OF THE 2008 NRC. REFER TO BRACED WALL PLANS FOR SHEATHING AND FASTENER REQUIREMENTS.

THESE PLANS ARE DESIGNED IN ACCORDANCE WITH ARCHITECTURAL PLANS PROVIDED BY SMITH DOUGLAS HOMES COMPLETED/REVISED ON 6/27/20. IT IS THE RESPONSIBILITY OF THE ARCHITECT TO OBTAIN ALL NECESSARY LABORATORY & TESTING, P.C. IF ANY CHANGES ARE MADE TO THE ARCHITECTURAL PLANS PRIOR TO CONSTRUCTION, SUMPIT CANNOT GUARANTEE THE ACCURACY OF THESE STRUCTURAL PLANS WHEN USED WITH ARCHITECTURAL PLANS DATED DIFFERENTLY THAN THE DATE LISTED ABOVE.

STRUCTURAL MEMBERS ONLY

ENGINEERING SEAL APPLIES ONLY TO STRUCTURAL COMPONENTS ON THIS DOCUMENT. SEAL DOES NOT INCLUDE CONSTRUCTION MEANS, METHODS, TECHNIQUES, SEQUENCES PROCEDURES OR SAFETY PRECAUTIONS. TO VERIFY THIS DOCUMENT'S ACCURACY OTHER PLANS TO BE REFERRED TO THE REGULATORY AGENCY OR SUMPIT ENGINEERING LABORATORY TESTING. P.C. FAILURE TO DO SO WILL VOID SUMPIT LIABILITY.

STRUCTURAL ANALYSIS BASED ON 2018 NRC.

ROOF FRAMING PLAN

SCALE: 1/8"=1'

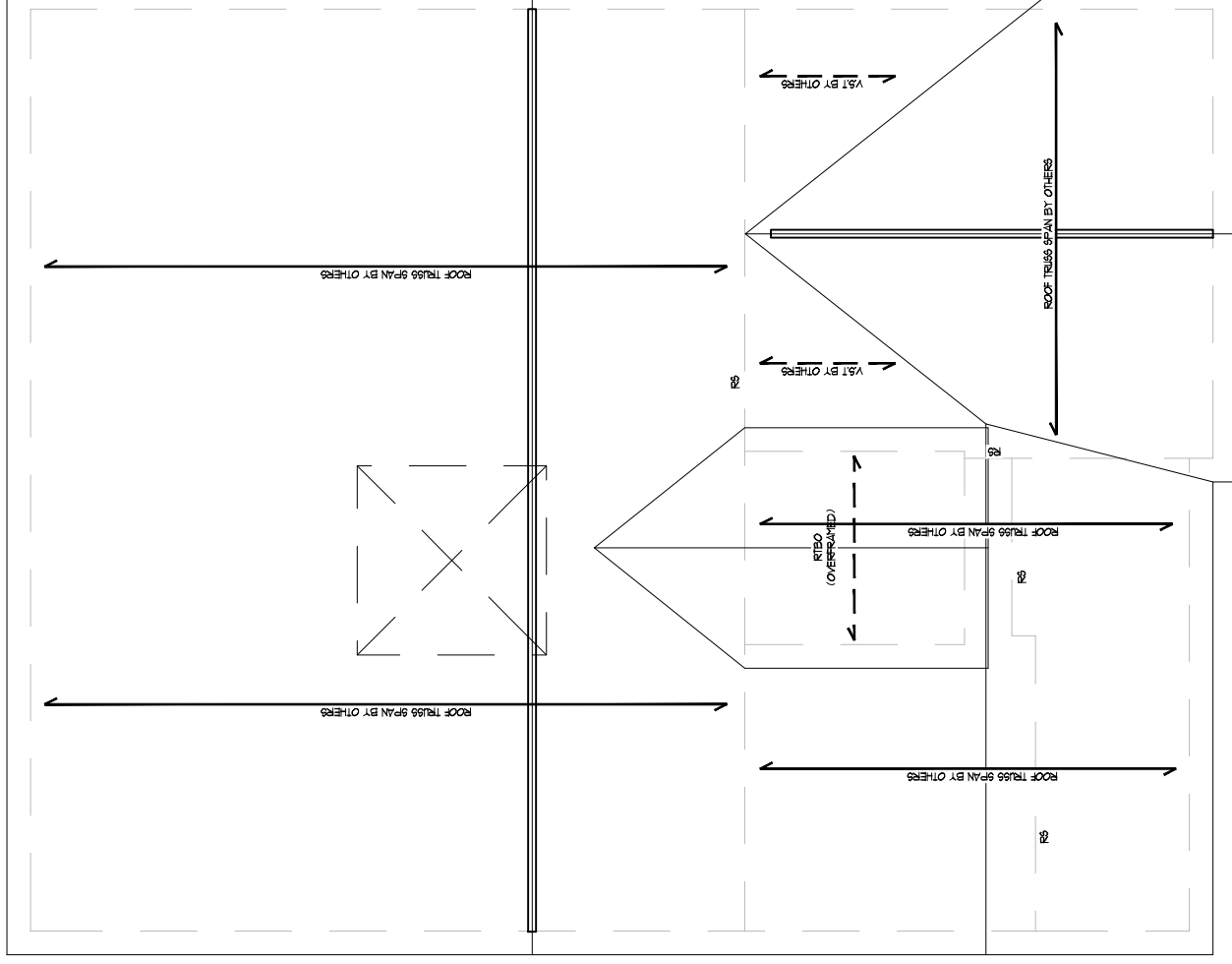

ELEVATION BEH

RS - ROOF SUPPORT

Cane Mill
Lot 26

STRUCTURAL MEMBERS ONLY

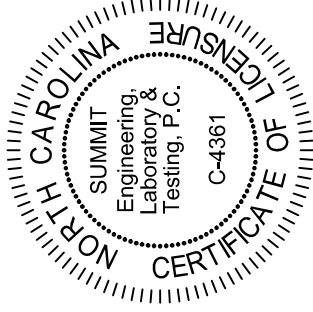

PROJECT: Reges 71
Roof Framing Plan
CLIENT: Smith Douglas Homes - Raleigh
2520 Reliance Ave.
Apex, NC 27539

DRAWING

DATE: 6/26/20

SCALE: 1/8"=1'-0"

PROJECT #: 3832.350

DRAWN BY: LBV

CHECKED BY: LAG

ORIGINAL INFORMATION

PROJECT # 3832.146 DATE 6/25/2018

REFER TO COVER SHEET FOR A COMPLETE LIST OF REVISIONS

SHEET

S5.1

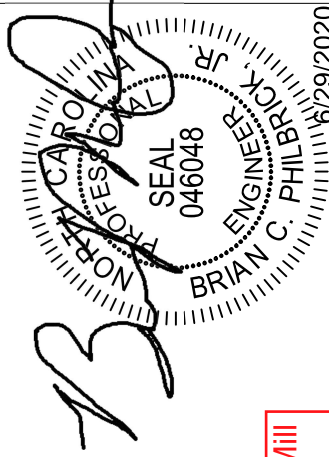

REQUIRED BRACED WALL PANEL CONNECTIONS			
METHOD	MATERIAL	MIN THICKNESS	REQUIRED CONNECTION
CS-USP	WOOD STRUCTURAL PANEL	3/8"	# PANEL EDGES # INTERMEDIATE SUPPORTS 6d COMMON NAILS # 17 O.C. 6d COMMON NAILS # 17 O.C.
GB	GYPFRM BOARD	1/2"	5d COOLER NAILS # 11 O.C. 5d COOLER NAILS # 11 O.C.
USP	WOOD STRUCTURAL PANEL	3/8"	6d COMMON NAILS # 6" O.C. 6d COMMON NAILS # 6" O.C.
FF	WOOD STRUCTURAL PANEL	7/16"	FFR FIGURE R602.06.4 FFR FIGURE R602.06.4

BRACED WALL NOTES:

- WALLS SHALL BE DESIGNED IN ACCORDANCE WITH SECTION R602.05 FROM THE 2015 INTERNATIONAL RESIDENTIAL CODE, ALL LOCAL AND STATE ADOPTIONS.
- WALLS ARE DESIGNED FOR SEISMIC ZONES A-C AND ULTIMATE DESIGN WIND SPEEDS UP TO 130 MPH.
- REFER TO ARCHITECTURAL PLAN FOR DOOR/WINDOW OPENING SIZES.
- TABLE R602.06.4 METHODS AND FASTENERS SHALL BE IN ACCORDANCE WITH THE INTERIOR SIDE OF EXTERIOR WALLS AND BOTH SIDES OF INTERIOR WALLS.
- ALL BRACED WALL PANELS SHALL BE FULL WALL HEIGHT AND SHALL NOT EXCEED 10 FEET FOR ISOLATED PANEL METHOD AND 17 FEET FOR CONTINUOUS SHEATHING METHOD WITHOUT ADDITIONAL ENGINEERING CALCULATIONS.
- THE INTERIOR SIDE OF EXTERIOR WALLS AND BOTH SIDES OF INTERIOR WALLS SHALL BE SHEATHED CONTINUOUSLY WITH MINIMUM 1/2" GYPFRM BOARD (MO).
- FOR CONTINUOUS SHEATHING METHOD, EXTERIOR WALLS SHALL BE SHEATHED ON ALL SHEATHABLE SURFACES INCLUDING WALL AREAS BETWEEN BRACED WALL PANELS.
- FLOORS SHALL NOT BE CANTILEVERED MORE THAN 24" BEYOND THE FOUNDATION OR BEARING WALL BELOW WITHOUT ADDITIONAL ENGINEERING CALCULATIONS.
- A BRACED WALL PANEL SHALL BE LOCATED WITHIN 10 FEET OF EACH END OF A BRACED WALL LINE.
- MAXIMUM SPACING BETWEEN BRACED WALL PANELS SHALL NOT EXCEED 20 FEET.
- MASONRY OR CONCRETE STEM WALLS WITH A LENGTH OF 48" OR LESS SUPPORTING A BRACED WALL PANEL SHALL BE DESIGNED IN ACCORDANCE WITH FIGURE R602.05 OF THE 2015 IRC.
- BRACED WALL PANEL CONNECTIONS TO FLOOR/CEILING SHALL BE CONSTRUCTED IN ACCORDANCE WITH SECTION R602.06.
- BRACED WALL PANEL CONNECTIONS TO ROOF SHALL BE CONSTRUCTED IN ACCORDANCE WITH SECTION R602.06.2.
- CRIPPLE WALLS AND WALL OUT BASEMENT WALLS SHALL BE DESIGNED IN ACCORDANCE WITH SECTION R602.06.1.
- PORTAL WALLS SHALL BE DESIGNED IN ACCORDANCE WITH FIGURE R602.06.4 (MO).
- ON SCHEMATIC SHADDED WALLS INDICATE BRACED WALL PANELS.

1. ALL HOLD-DOWNS FOR BRACED WALL END CONDITIONS PER SECTION R602.05 AND FIGURE R602.07 OF THE 2015 IRC.

NOTE: WALL SHEATHING AND FASTENERS HAVE BEEN SPECIFIED TO BE INSTALLED WITHIN 1" OF LOAD PATH IN ACCORDANCE WITH METHOD 3 OF SECTION R602.05 OF THE 2015 IRC.

THESE PLANS ARE DESIGNED IN ACCORDANCE WITH ARCHITECTURAL PLANS PROVIDED BY SMITH DOUGLAS HOMES. THESE PLANS HAVE BEEN REVIEWED BY THE LABORATORY & TESTING, P.C. IF ANY CHANGES ARE MADE TO THE ARCHITECTURAL PLANS PRIOR TO CONSTRUCTION, SUBMITTAL CANNOT GUARANTEE THE ADEQUACY OF THESE STRUCTURAL PLANS WHEN USED WITH ARCHITECTURAL PLANS DATED DIFFERENTLY THAN THE DATE LISTED ABOVE.

STRUCTURAL MEMBERS ONLY

ENGINEERING SEAL APPLIES ONLY TO STRUCTURAL COMPONENTS ON THIS DOCUMENT. SEAL DOES NOT INCLUDE CONSTRUCTION MEANS, METHODS, TECHNIQUES, SEQUENCES, PROCEDURES OR SAFETY PRECAUTIONS. NO SEQUENCE OF WORK IS SPECIFICALLY IDENTIFIED IN THESE PLANS. BE BRAGHT TO THE ATTENTION OF THE SUBMITTER OF THESE PLANS TO THE LABORATORY & TESTING, P.C. FAILURE TO DO SO WILL VOID SUMMIT LIABILITY.

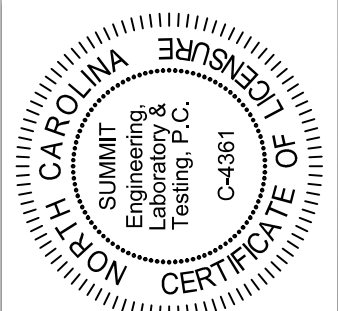

PROJECT: Reges 71
PROJECT: First Floor Bracing
CLIENT: Smith Douglas Homes - Raleigh
 2520 Reliance Ave.
 Apex, NC 27539

DRAWING DATE: 6/26/20
 SCALE: 1/8" = 1'-0"
 PROJECT #: 3832.350
 DRAIN BY: LBV
 CHECKED BY: LAG

ORIGINAL INFORMATION
 PROJECT #: 3832.146 DATE: 6/25/2018
 REFER TO COVER SHEET FOR A COMPLETE LIST OF REVISIONS

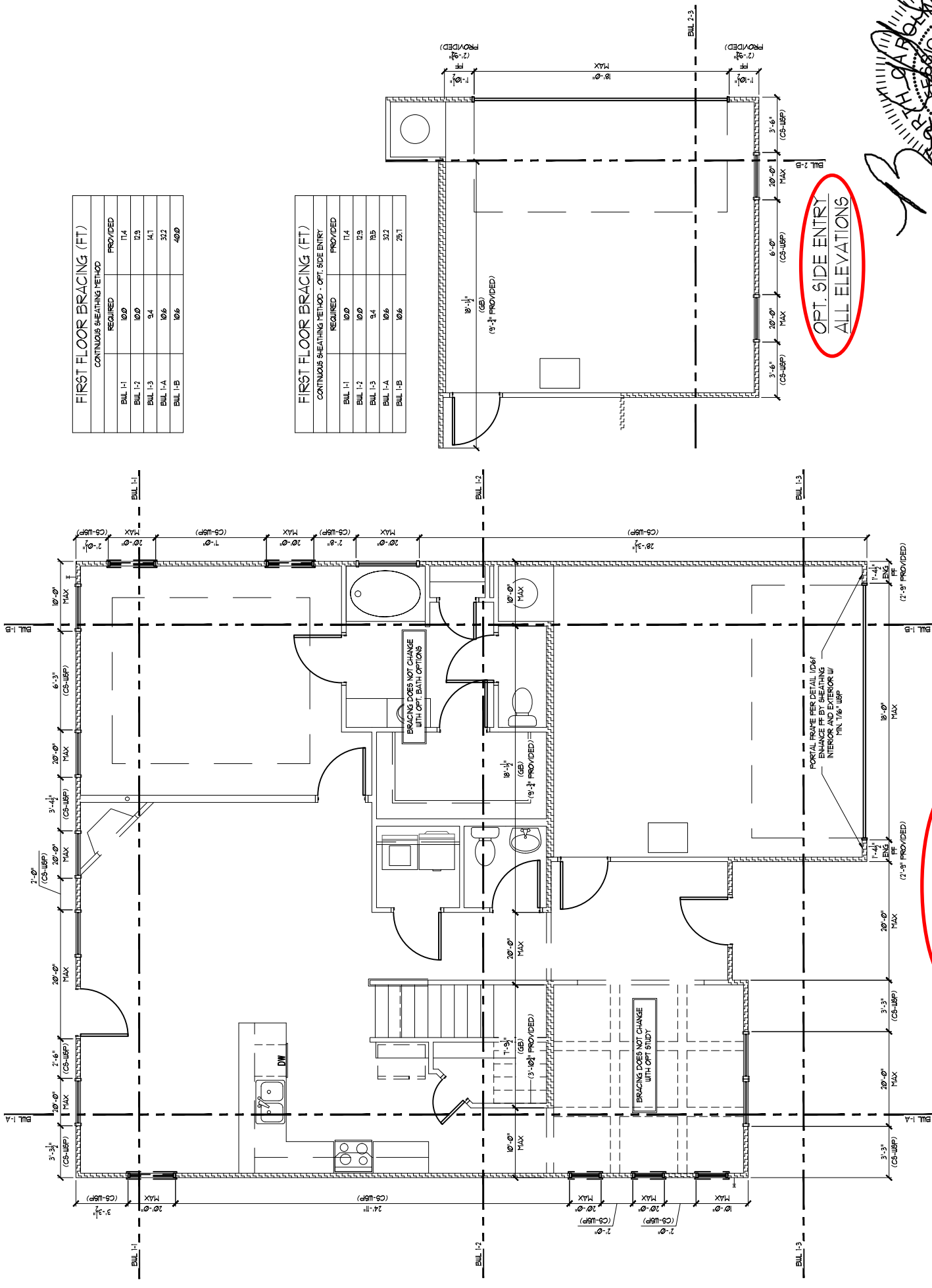

FIRST FLOOR BRACING (FT)

CONTINUOUS SHEATHING METHOD		
BILL I-I	REQUIRED	PROVIDED
BILL I-1	0/0	T1.4
BILL I-2	0/0	T2.5
BILL I-3	3.4	I.1
BILL I-4	0/6	3.2
BILL I-5	0/6	4.0

FIRST FLOOR BRACING (FT)

CONTINUOUS SHEATHING METHOD - OPT. SIDE ENTRY		
BILL I-I	REQUIRED	PROVIDED
BILL I-1	0/0	T1.4
BILL I-2	0/0	T2.5
BILL I-3	3.4	I.1
BILL I-4	0/6	3.2
BILL I-5	0/6	25.1

OPT. SIDE ENTRY
 ALL ELEVATIONS

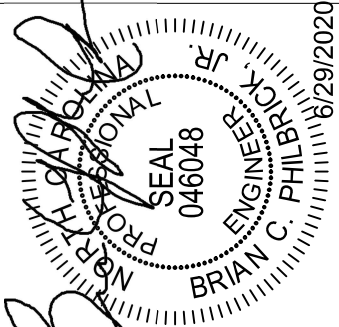

Cane Mill
 Lot 26

REQUIRED BRACED WALL PANEL CONNECTIONS		
METHOD	MATERIAL THICKNESS	REQUIRED CONNECTION
CS-USP	WOOD STRUCTURAL PANEL 3/8"	# PANEL EDGES # INTERMEDIATE SUPPORTS 6d COMMON NAILS # 6" O.C. 6d COMMON NAILS # 17" O.C.
GB	GYPFRM BOARD 1/2"	5d COOLER NAILS # 17" O.C. 6d COMMON NAILS # 6" O.C.
USP	WOOD STRUCTURAL PANEL 3/8"	6d COMMON NAILS # 6" O.C.
FF	WOOD STRUCTURAL PANEL 7/8"	PER FIGURE R602.06.4 PER FIGURE R602.06.4

BRACED WALL NOTES:

- WALLS SHALL BE DESIGNED IN ACCORDANCE WITH SECTION R602.0 FROM THE 2015 INTERNATIONAL RESIDENTIAL CODE, ALL LOCAL AND STATE ADOPTIONS.
- WALLS ARE DESIGNED FOR SEISMIC ZONES A-C AND ULTIMATE DESIGN WIND SPEEDS UP TO 130 MPH.
- REFER TO ARCHITECTURAL PLAN FOR DOOR/WINDOW OPENING SIZES.
- TABLE R602.06.4 METHODS AND FASTENERS SHALL BE IN ACCORDANCE WITH ALL BRACED WALL PANELS.
- ALL BRACED WALL PANELS SHALL BE FULL WALL HEIGHT AND SHALL NOT EXCEED 10 FEET FOR ISOLATED PANEL METHOD AND 17 FEET FOR CONTINUOUS SHEATHING METHOD WITHOUT ADDITIONAL ENGINEERING CALCULATIONS.
- THE INTERIOR SIDE OF EXTERIOR WALLS AND BOTH SIDES OF INTERIOR WALLS SHALL BE SHEATHED CONTINUOUSLY WITH MINIMUM 1/2" GYPFRM BOARD (MGO).
- FOR CONTINUOUS SHEATHING METHOD, EXTERIOR WALLS SHALL BE SHEATHED ON ALL SHEATHABLE SURFACES INCLUDING WALL AREAS BETWEEN BRACED WALL PANELS.
- FLOORS SHALL NOT BE CANTILEVERED MORE THAN 24" BEYOND THE FOUNDATION OR BEARING WALL BELOW WITHOUT ADDITIONAL ENGINEERING CALCULATIONS.
- A BRACED WALL PANEL SHALL BE LOCATED WITHIN 10 FEET OF EACH END OF A BRACED WALL LINE.
- MAXIMUM JOIST SPACING BETWEEN BRACED WALL PANELS SHALL NOT EXCEED 20 FEET.
- MASONRY OR CONCRETE STEM WALLS WITH A LENGTH OF 48" OR LESS SUPPORTING A BRACED WALL PANEL SHALL BE DESIGNED IN ACCORDANCE WITH FIGURE R602.06.5 OF THE 2015 IRC.
- BRACED WALL PANELS SHALL BE CONSTRUCTED IN ACCORDANCE WITH SECTION R602.06.9.
- BRACED WALL PANEL CONNECTIONS TO ROOF SHALL BE CONSTRUCTED IN ACCORDANCE WITH SECTION R602.06.2.
- CRIPPLE WALLS AND WALL OUT BASEMENT WALLS SHALL BE DESIGNED IN ACCORDANCE WITH SECTION R602.06.10.
- PORTAL WALLS SHALL BE DESIGNED IN ACCORDANCE WITH FIGURE R602.06.4 (MGO).
- ON SCHEMATIC SHADDED WALLS INDICATE BRACED WALL PANELS.
- ABBREVIATIONS:
GB = GYPFRM BOARD
CS-USP = CONT. SHEATHED
FF = PORTAL FRAME
USP = WOOD STRUCTURAL PANEL
ENG = ENGINEER SOLUTION
FF-ENG = ENG. PORTAL FRAME

INSTALL HOLD-DOWNS FOR BRACED WALL END CONDITIONS PER SECTION R602.05 AND FIGURE R602.07 OF THE 2015 IRC.

NOTE: WALL SHEATHING AND FASTENERS HAVE BEEN SPECIFIED TO BE INSTALLED WITHIN 1" LOAD PATH IN ACCORDANCE WITH METHOD 3 OF SECTION R602.05 OF THE 2015 IRC.

THESE PLANS ARE DESIGNED IN ACCORDANCE WITH ARCHITECTURAL PLANS PROVIDED BY SMITH DOUGLAS HOMES. ANY CHANGES TO THESE PLANS SHALL BE MADE TO THE ARCHITECTURAL PLANS PRIOR TO CONSTRUCTION. SMITTE CANNOT GUARANTEE THE ACCURACY OF THESE STRUCTURAL PLANS WHEN USED WITH ARCHITECTURAL PLANS DATED DIFFERENTLY THAN THE DATE LISTED ABOVE.

STRUCTURAL MEMBERS ONLY

ENGINEERING SEAL APPLIES ONLY TO STRUCTURAL COMPONENTS ON THIS DOCUMENT. SEAL DOES NOT INCLUDE CONSTRUCTION MEANS, METHODS, TECHNIQUES, SEQUENCES, PROCEDURES OR SAFETY PRECAUTIONS. NO SEVEN (7) DAYS DISCREPANCY CORRECTION PLANS TO BE PREPARED BY THE CONTRACTOR PRIOR TO SUBMITTING TO THE ARCHITECT FOR TESTING. P.C. FAILURE TO DO SO WILL VOID SUMMIT LIABILITY.

STRUCTURAL ANALYSIS BASED ON 2015 IRC.

SECOND FLOOR BRACING PLAN

SCALE: 1/8" = 1'

SECOND FLOOR BRACING (FT)		
CONTINUOUS SHEATHING METHOD	REQUIRED	PROVIDED
BILL 2-1	3.1	216
BILL 2-2	3.1	3.1
BILL 2-A	5.1	232
BILL 2-B	5.1	212

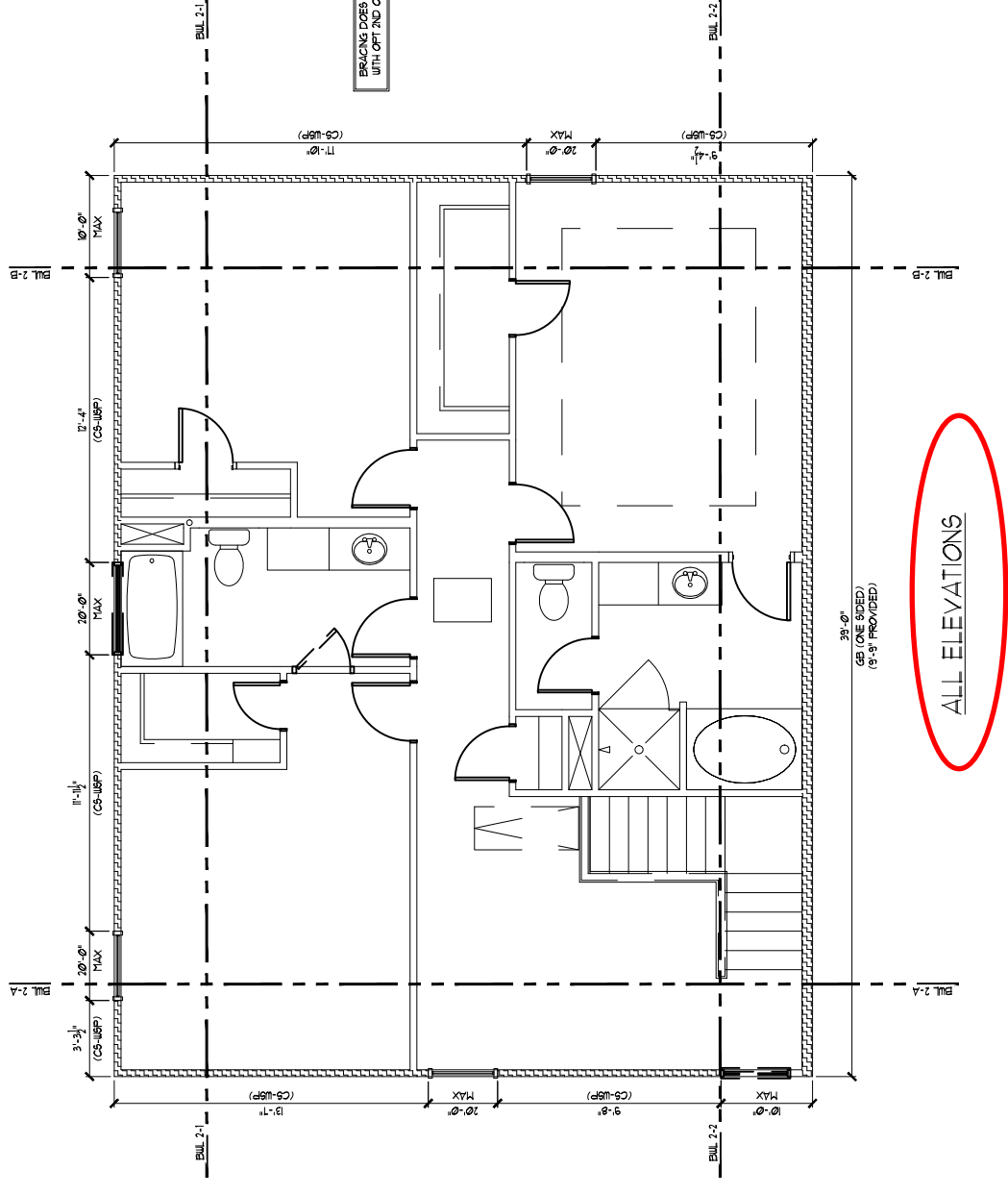

ALL ELEVATIONS

BRACING DOES NOT CHANGE WITH OPT AND OWNERS SUITE

SUMMIT
ENGINEERING LABORATORY TESTING
3070 HAMMOND BUSINESS
PLACE, SUITE 171
RALEIGH, NC 27603
OFFICE: 919.380.9991
FAX: 919.380.9993
WWW.SUMMIT-COMPANIES.COM

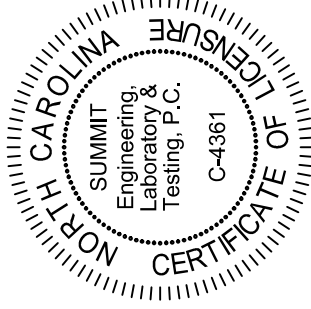

PROJECT: Reg 09 71
Second Floor Bracing
CLIENT: Smith Douglas Homes - Raleigh
2520 Reliance Ave.
Apex, NC 27539

DRAWING

DATE: 6/26/20

SCALE: 1/8"=1'-0"

PROJECT #: 3832.350

DRAWN BY: LBV

CHECKED BY: LAG

ORIGINAL INFORMATION

PROJECT #: 3832.146
DATE: 6/29/2018

REFER TO COVER SHEET FOR A COMPLETE LIST OF REVISIONS

SHEET

S8.0

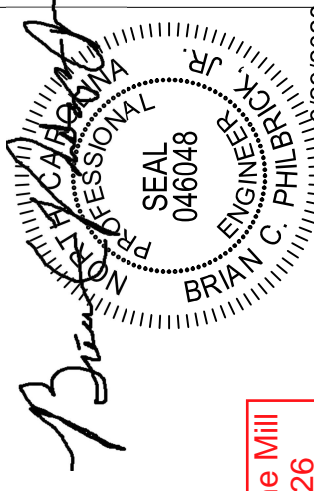

Cane Mill
Lot 26

STRUCTURAL MEMBERS ONLY
6/29/2020

GENERAL STRUCTURAL NOTES:

- The design professional whose seal appears on these drawings is the structural engineer of record (SER) for this project. The SER bears the responsibility of the primary structural elements and the performance of this structure. No other party may revise, alter, or delete any structural aspects of these construction documents without written permission of SUMMIT Engineering, Laboratory & Testing, P.C. (SUMMIT) or the SER. For the purposes of these construction documents the SER and SUMMIT shall be considered the same entity.
- The structure is only stable in its completed form. The contractor shall provide all required temporary bracing during construction to stabilize the structure.
- The SER is not responsible for construction sequences, methods, or techniques in connection with the construction of this structure. The SER will not be held responsible for the contractor's failure to conform to the contract documents, should any non-conformities occur.
- Any structural elements or details not fully developed on the construction drawings shall be completed under the direction of a licensed professional engineer. These shop drawings shall be submitted to SUMMIT for review before any construction begins. The shop drawings will be reviewed for overall compliance as it relates to the structural design of this project. Verification of the shop drawings for dimensions, or for actual field conditions, is not the responsibility of the SER or SUMMIT.
- Verification of assumed field conditions is not the responsibility of the SER. The contractor shall verify the field conditions for accuracy and report any discrepancies to SUMMIT before construction begins.
- The SER is not responsible for any secondary structural elements or non-structural elements, except for the elements specifically noted on the structural drawings.
- This structure and all construction shall conform to all applicable sections of the international residential code.
- This structure and all construction shall conform to all applicable sections of the 2018 North Carolina Residential Code (NCRC) and any local codes or restrictions

FOUNDATIONS:

- Foundations shall be constructed in accordance with chapter 4 of the 2018 NC Residential Building Code (Special consideration shall be given to Chapter 45 in wind zones above 130mph)
- Footing sizes based on a presumptive soil bearing capacity of 2000 PSF. Contractor is solely responsible for verifying the suitability of the site soil conditions at the time of construction
- Maximum depth of unbalanced fill against masonry walls to be as specified in section R404.1 of the 2018 NCRC
- The structural engineer has not performed a subsurface investigation. Verification of this assumed value is the responsibility of the owner or the contractor. Should any adverse soil condition be encountered the SER must be contacted before proceeding.
- The bottom of all footings shall extend below the frost line for the region in which the structure is to be constructed. However, the bottom of all footings shall be a minimum of 12" below grade.
- Any fill shall be placed under the direction or recommendation of a licensed professional engineer. The resulting soil shall be compacted to a minimum of 95% maximum dry density.
- Excavations of footings shall be lined temporarily with a 6 mil polyethylene membrane if placement of concrete does not occur within 24 hours of excavation.
- No concrete shall be placed against any subgrade containing water, ice, frost, or loose material.
- Each crawl space pier shall bear in the middle third of its respective footing and each girder shall bearing in the middle third of the piers. Pilasters to be bonded to perimeter foundation wall
- Crawl spaced to be graded level and clear of all debris
- Provide foundation waterproofing and drain with positive slope to outlet as required by site conditions
- Energy efficiency compliance and insulation of the structure to be in accordance with chapter 11 of the 2018 NCRC

CONCRETE:

- Concrete shall have a normal weight aggregate and a minimum compressive strength (f'c) at 28 days of 3000 psi, unless otherwise noted on the plan.
- Concrete shall be proportioned, mixed, and placed in accordance with the latest editions of ACI 318: "Building Code Requirements for Reinforced Concrete" and ACI 301: "Specifications for Structural Concrete for Buildings".
- Air entrained concrete must be used for all structural elements exposed to freeze/thaw cycles and deicing chemicals. Air entrainment amounts (in percent) shall be within -1% to +2% of target values as follows:
 - Footings: 5%
 - Exterior Slabs: 5%
- No admixtures shall be added to any structural concrete without written permission of the SER
- Concrete slabs-on-grade shall be constructed in accordance with ACI 302.1R-96: "Guide for Concrete Slab and Slab Construction".
- The concrete slab-on-grade has been designed using a subgrade modulus of k=250 pci and a design loading of 200 psf. The SER is not responsible for differential settlement, slab cracking or other future defects resulting from unreported conditions not in accordance with the above assumptions.
- Control or saw cut joints shall be spaced in interior slabs-on-grade at a maximum of 15'-0" O.C. and in exterior slabs-on-grade at a maximum of 10'-0" unless otherwise noted.
- Control or saw cut joints shall be produced using conventional process within 4 to 12 hours after the slab has been finished
- Reinforcing steel may not extend through a control joint. Reinforcing steel may extend through a saw cut joint.
- All welded wire fabric (W.W.F.) for concrete slabs-on-grade shall be placed at mid-depth of slab. The W.W.F. shall be securely supported during the concrete pour. Fibermesh may be used in lieu of W.W.F.

CONCRETE REINFORCEMENT:

- Fibrous concrete reinforcement, or fibermesh, specified in concrete slabs-on-grade may be used for control of cracking due to shrinkage and thermal expansion/contraction, lowered water migration, an increase in impact capacity, increased abrasion resistance, and residual strength.
- Fibermesh reinforcing to be 100% virgin polypropylene fibers containing no reprocessed olefin materials and specifically manufactured for use as concrete secondary reinforcement.
- Application of fibermesh per cubic yard of concrete shall equal a minimum of 0.1% by volume (1.5 pounds per cubic yard)
- Fibermesh shall comply with ASTM C1116, any local building code requirements, and shall meet or exceed the current industry standard.
- Steel Reinforcing bars shall be new billet steel conforming to ASTM A615, grade 60.
- Detailing, fabrication, and placement of reinforcing steel shall be in accordance with the latest edition of ACI 315: "Manual of Standard Practice for Detailing Concrete Structures"
- Horizontal footing and wall reinforcement shall be continuous and shall have 90° bends, or corner bars with the same size/spacing as the horizontal reinforcement with a class B tension splice.
- Lap reinforcement as required, a minimum of 40 bar diameters for tension or compression unless otherwise noted. Splices in masonry shall be a minimum of 48 bar diameters.
- Where reinforcing dowels are required, they shall be equivalent in size and spacing to the vertical reinforcement. The dowel shall extend 48 bar diameters vertically and 20 bar diameters into the footing.
- Where reinforcing steel is required vertically, dowels shall be provided unless otherwise noted.

WOOD FRAMING:

- Solid sawn wood framing members shall conform to the specifications listed in the latest edition of the "National Design Specification for Wood Construction" (NDS). Unless otherwise noted, all wood framing members are designed to be Spruce-Pine-Fir (SPF) #2.
- LVL or PSL engineered wood shall have the following minimum design values:
 - E = 1,900,000 psi
 - Fb = 2600 psi
 - Fv = 285 psi
 - Fc = 700 psi
- Wood in contact with concrete, masonry, or earth shall be pressure treated in accordance with AWPA standard C-15. All other moisture exposed wood shall be treated in accordance with AWPA standard C-2
- Nails shall be common wire nails unless otherwise noted.
- Lag screws shall conform to ANSI/ASME standard B18.2.1-1981. Lead holes for lag screws shall be in accordance with NDS specifications.
- All beams shall have full bearing on supporting framing members unless otherwise noted.
- Exterior and load bearing stud walls are to be 2x4 SPF#2 @16" O.C. unless otherwise noted. Studs shall be continuous from the sole plate to the double top plate. Studs shall only be discontinuous at headers for window/door openings. A minimum of one king stud shall be placed at each end of the header. King studs shall be continuous.
- Individual studs forming a column shall be attached with one 10d nail @6" O.C. staggered. The stud column shall be continuous to the foundation or beam. The column shall be fully blocked at all floor levels to ensure proper load transfer.
- Multi-ply beams shall have each ply attached with (3)10d nails @ 24" O.C.
- Fitch beams and four and five ply beams shall be bolted together with (2) rows of 1/2" dia. through bolts staggered @24" O.C. w/ 2" edge distance and (2) bolts located at 6" from each end, unless noted otherwise.

WOOD TRUSSES:

- The wood truss manufacturer/fabricator is responsible for the design of the wood trusses. Submit sealed shop drawings and supporting calculations to the SER for review prior to fabrication. The SER shall have a minimum of five (5) days for review. The review by the SER shall review for overall compliance with the design documents. The SER shall assume no responsibility for the correctness for the structural design for the wood trusses.
- The wood trusses shall be designed for all required loadings as specified in the local building code, the ASCE Standard "Minimum Design Loads for Buildings and Other Structures." (ASCE 7-10), and the loading requirements shown on these specifications. The truss drawings shall be coordinated with all other construction documents and provisions provided for loads shown on these drawings including but not limited to HVAC equipment, piping, and architectural fixtures attached to the trusses.
- The trusses shall be designed, fabricated, and erected in accordance with the latest edition of the "National Design Specification for Wood Construction." (NDS) and "Design Specification for Metal Plate Connected Wood Trusses."
- The truss manufacturer shall provide adequate bracing information in accordance with "Commentary and Recommendations for Handling, Installing, and Bracing Metal Plate Connected Wood Trusses" (HIB-91). This bracing, both temporary and permanent, shall be shown on the shop drawings. Also, the shop drawings shall show the required attachments for the trusses.
- Any chords or truss webs shown on these drawings have been shown as a reference only. The final design of the trusses shall be per the manufacturer.

WOOD STRUCTURAL PANELS:

- Fabrication and placement of structural wood sheathing shall be in accordance with the APA Design/Construction Guide "Residential and Commercial," and all other applicable APA standards.
- All structurally required wood sheathing shall bear the mark of the APA.
- Wood wall sheathing shall comply with the requirements of local building codes for the appropriate state as indicated on these drawings. Refer to wall bracing notes in plan set for more information. Sheathing shall be applied with the long direction perpendicular to framing, unless noted otherwise.
- Roof sheathing shall be APA rated sheathing exposure 1 or 2. Roof sheathing shall be continuous over two supports and attached to its supporting roof framing with (1)-8d CC nail at 6"o/c at panel edges and at 12"o/c in panel field unless otherwise noted on the plans. Sheathing shall be applied with the long direction perpendicular to framing. Sheathing shall have a span rating consistent with the framing spacing. Use suitable edge support by use of plywood clips or lumber blocking unless otherwise noted. Panel end joints shall occur over framing. Apply building paper over the sheathing as required by the state Building Code.
- Wood floor sheathing shall be APA rated sheathing exposure 1 or 2. Attach sheathing to its supporting framing with (1)-8d CC ringshank nail at 6"o/c at panel edges and at 12"o/c in panel field unless otherwise noted on the plans. Sheathing shall be applied perpendicular to framing. Sheathing shall have a span rating consistent with the framing spacing. Use suitable edge support by use of T&G plywood or lumber blocking unless otherwise noted. Panel end joints shall occur over framing. Apply building paper over the sheathing as required by the state Building Code.
- Sheathing shall have a 1/8" gap at panel ends and edges as recommended in accordance with the APA.

STRUCTURAL FIBERBOARD PANELS:

- Fabrication and placement of structural fiberboard sheathing shall be in accordance with the applicable AFA standards.
- Fiberboard wall sheathing shall comply with the requirements of local building codes for the appropriate state as indicated on these drawings. Refer to wall bracing notes in plan set for more information.
- Sheathing shall have a 1/8" gap at panel ends and edges are recommended in accordance with the AFA.

EXTERIOR WOOD FRAMED DECKS:

- Decks are to be framed in accordance with local building codes and as referenced on the structural plans, either through code references or construction details.

STRUCTURAL STEEL:

- Structural steel shall be fabricated and erected in accordance with the American Institute of Steel Construction "Code of Standard Practice for Steel Buildings and Bridges" and of the manual of Steel Construction "Load Resistance Factor Design" latest editions.
- All steel shall have a minimum yield stress (Fy) of 36 ksi unless otherwise noted.
- Welding shall conform to the latest edition of the American Welding Society's Structural Welding Code AWS D1.1. Electrodes for shop and field welding shall be class E70XX. All welding shall be performed by a certified welder per the above standards.

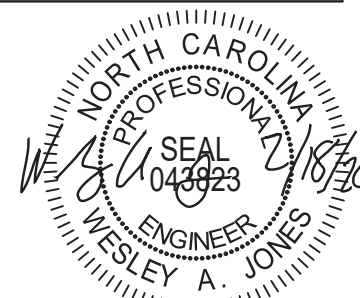

STRUCTURAL MEMBERS ONLY

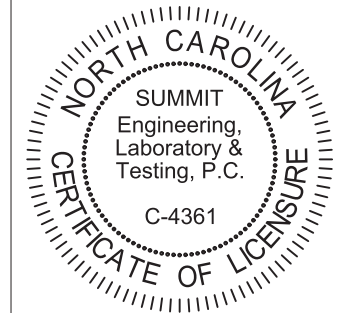

PROJECT
Standard Details
Notes and Specifications
 CLIENT
Smith Douglas Homes
110 Village Trail, Suite 215
Woodstock, GA 30188

CURRENT DRAWING

DATE: 2/18/20
 SCALE: NTS
 PROJECT #: 3832
 DRAWN BY: LBV
 CHECKED BY: WAJ

ORIGINAL DRAWING

NO.	DATE	PROJECT #
0	1/7/16	3832

REFER TO COVER SHEET FOR A COMPLETE LIST OF REVISIONS

SHEET

CS2

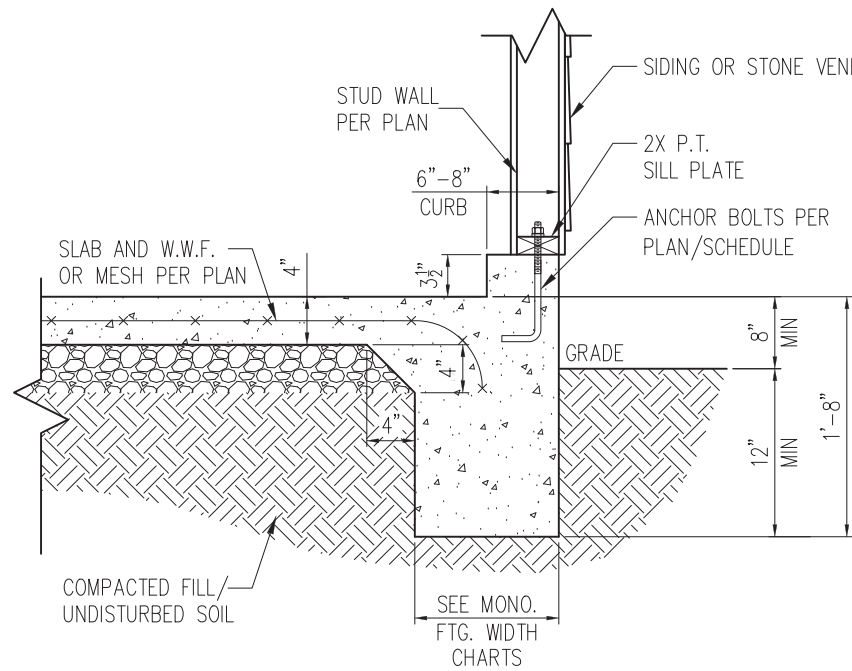

STANDARD - SIDING/STONE

1 TYP. GARAGE CURB DETAIL
D1m 3/4" = 1'-0"

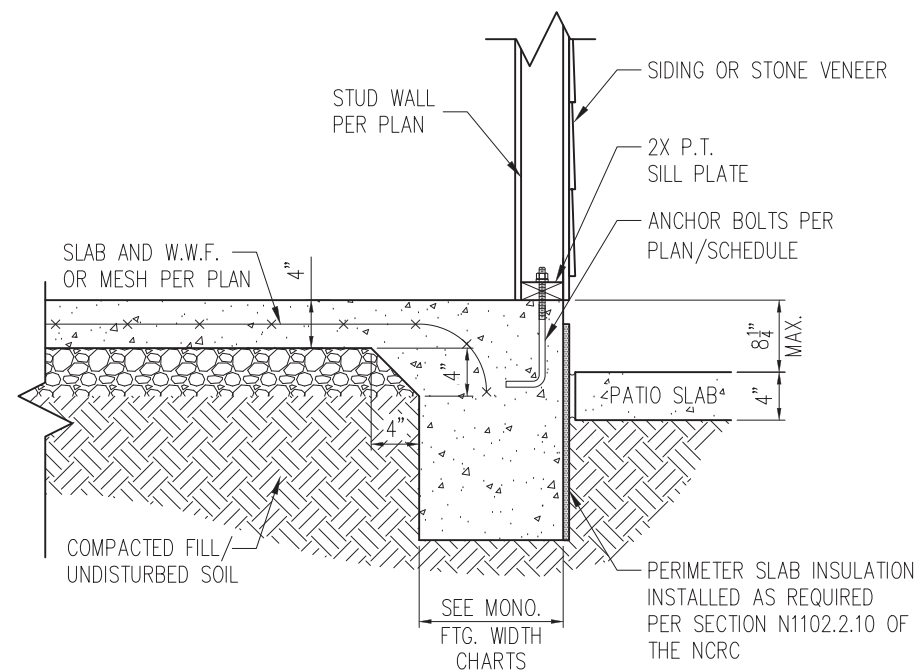

STANDARD - SIDING/STONE

2 PATIO SLAB DETAIL
D1m 3/4" = 1'-0"

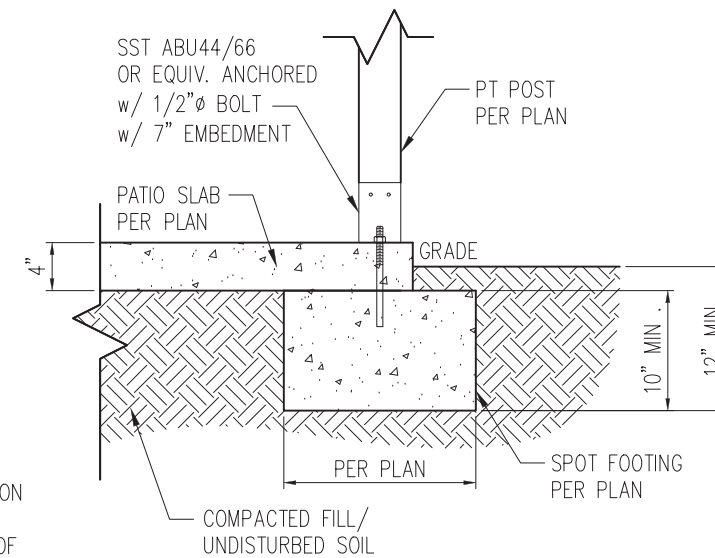

2A COVERED PATIO DETAIL
D1m 3/4" = 1'-0"

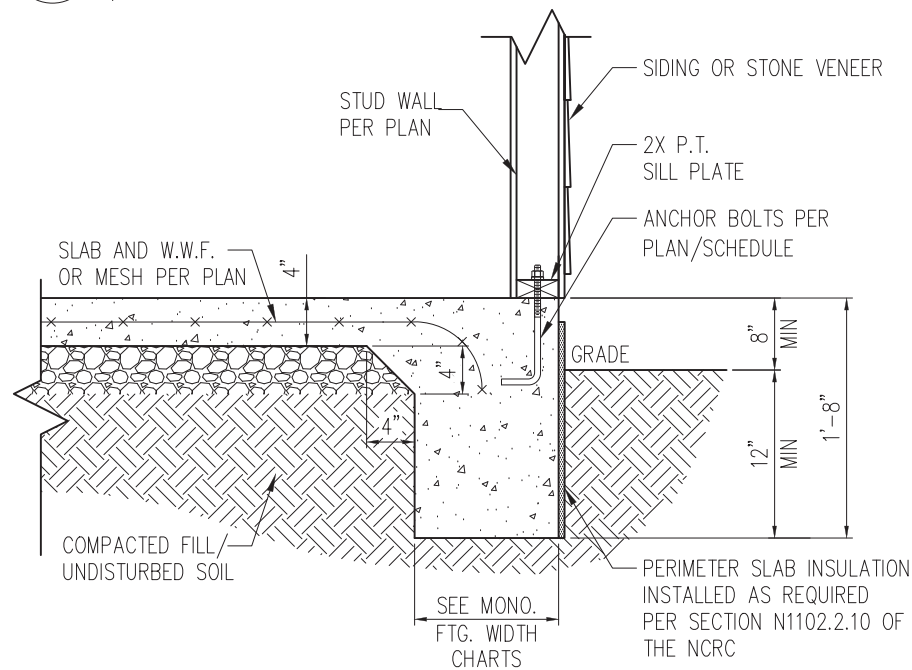

STANDARD - SIDING/STONE

3 TYP. SLAB DETAIL
D1m 3/4" = 1'-0"

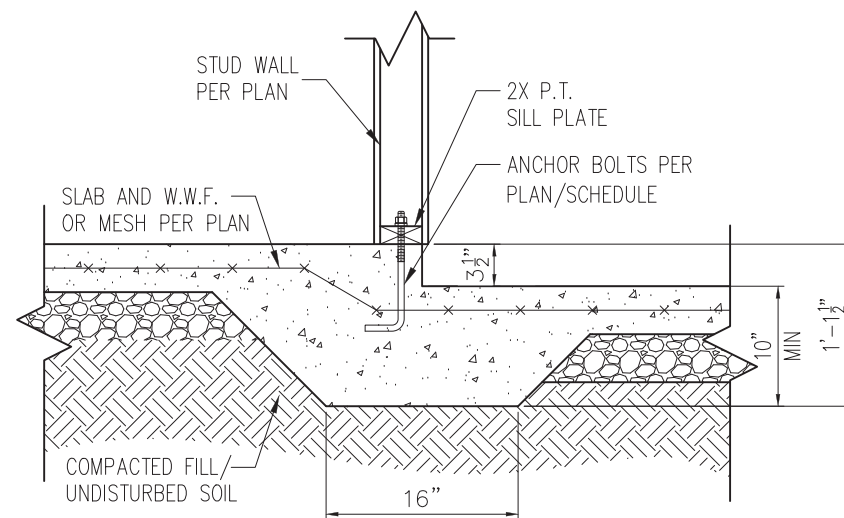

4 STEP IN GARAGE
D1m 3/4" = 1'-0"

WALL ANCHOR SCHEDULE

TYPE OF ANCHOR	MIN. CONC. EMBEDMENT	SPACING EMBEDMENT	INTERIOR WALL	EXTERIOR WALL
1/2" Ø A307 BOLTS w/ STD. 90° BEND	7"	6'-0"	YES	YES
SST - MAS	4"	5'-0"	NO	YES
HILTI KWIK BOLT KBI 1/2-2-3/4	2-1/4"	6'-0"	YES	NO
1/2" Ø HILTI THREADED ROD w/ HIT HY150 ADHESIVE	7"	6'-0"	YES	YES

NOTE: INSTALL ALL ANCHORS 12" MAX. FROM ALL BOTTOM PLATE ENDS AND JOINTS.

MONOLITHIC FOOTING WIDTH

# OF STORIES	WIDTH BASED ON SOIL BEARING CAPACITY		
	1500 PSF	2000 PSF	2500 PSF
1 STORY - STD.	16"	16"	16"
1 STORY - BRICK VENEER	21"	21"	21"
2 STORY - STD.	20"	16"	16"
2 STORY - BRICK VENEER	25"	21"	21"

*5" BRICK LEDGE HAS BEEN ADDED TO THE MONOLITHIC FOOTING WIDTH FOR BRICK SUPPORT

- NOTES:
- REFER TO GENERAL NOTES & SPECIFICATIONS ON SHEET CS2 FOR ADDITIONAL INFORMATION.
 - PROVIDE 6 MIL VAPOR BARRIER UNDER ALL SLABS-ON-GRADE.
 - SEE ARCH. DWGS. FOR ALL TOP OF THE SLAB ELEVATIONS, SLOPES AND DEPRESSIONS.

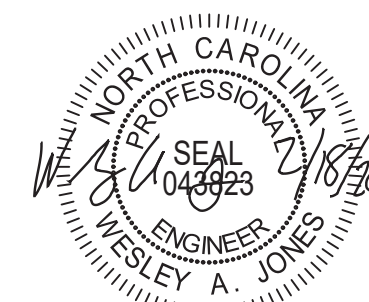

STRUCTURAL MEMBERS ONLY

SUMMIT
ENGINEERING LABORATORY TESTING
3070 HAMMOND BUSINESS PLACE,
SUITE 171, RALEIGH, NC 27603
OFFICE: 919.380.9991
FAX: 919.380.9993
WWW.SUMMIT-COMPANIES.COM

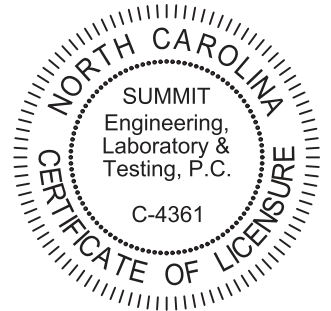

PROJECT
Standard Details
Monolithic Slab Details
CLIENT
Smith Douglas Homes
110 Village Trail, Suite 215
Woodstock, GA 30188

CURRENT DRAWING
DATE: 2/18/20
SCALE: NTS
PROJECT #: 3832
DRAWN BY: LBV
CHECKED BY: WAJ

ORIGINAL DRAWING
NO. DATE PROJECT #
0 1/7/16 3832

REFER TO COVER SHEET FOR A COMPLETE LIST OF REVISIONS

SHEET

D1m

*BRICK TIES SPACED @ 16" O.C. HORIZ. & 24" O.C. VERT. AND 3/16" Ø WEEP HOLES @ 33" O.C.

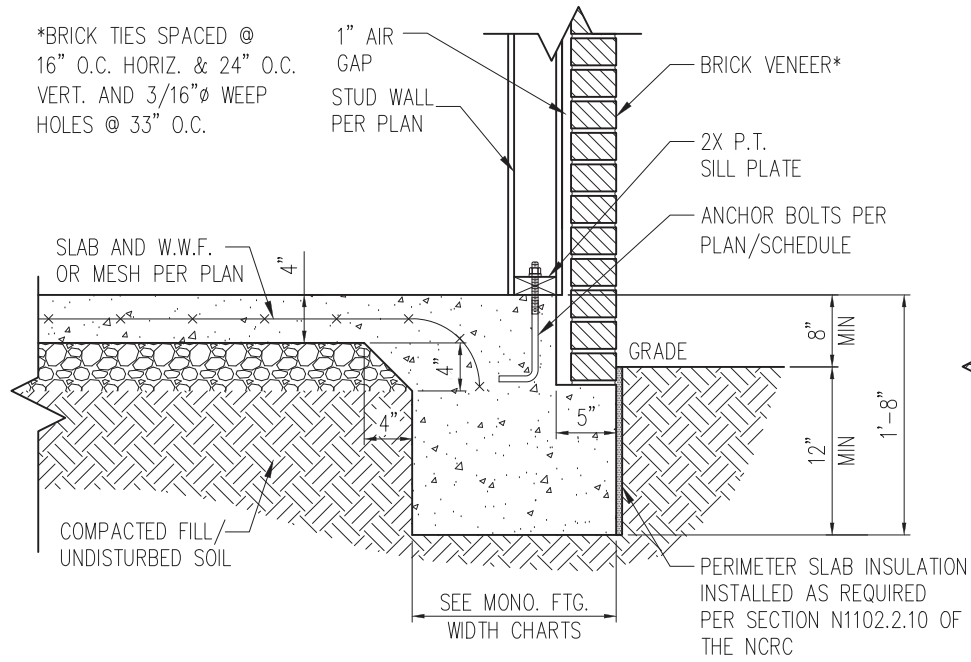

STANDARD - BRICK

1 TYP. SLAB DETAIL W/ BRICK VENEER
D2m 3/4" = 1'-0"

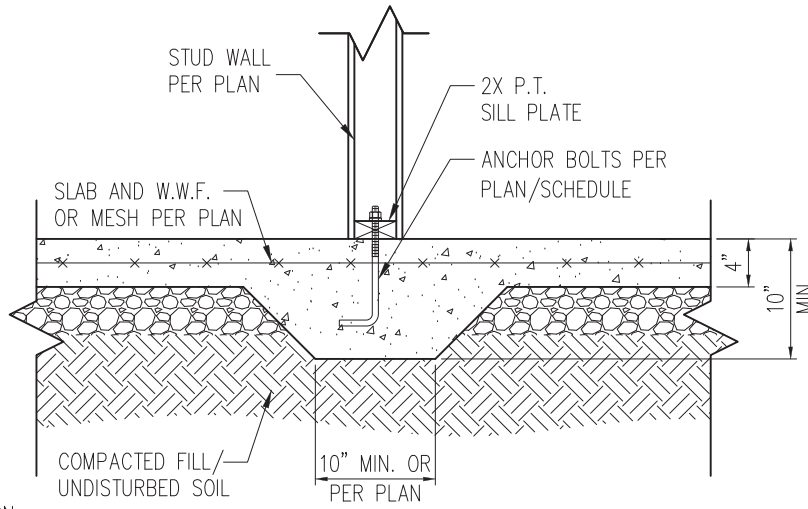

3 TYP. THICKENED SLAB DETAIL
D2m 3/4" = 1'-0"

*BRICK TIES SPACED @ 16" O.C. HORIZ. & 24" O.C. VERT. AND 3/16" Ø WEEP HOLES @ 33" O.C.

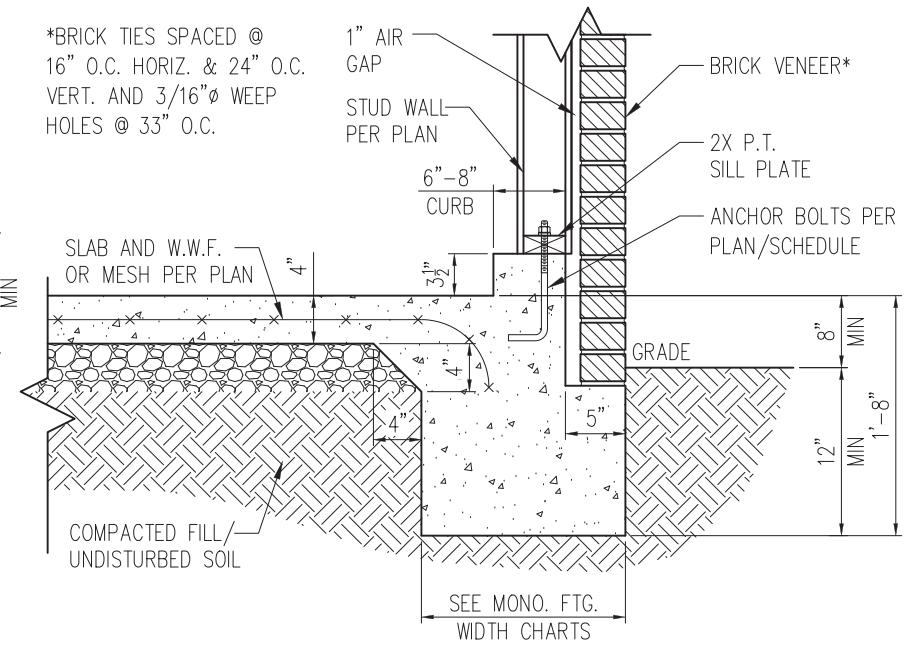

STANDARD - BRICK

5 TYP. GARAGE CURB DETAIL W/ BRICK VENEER
D2m 3/4" = 1'-0"

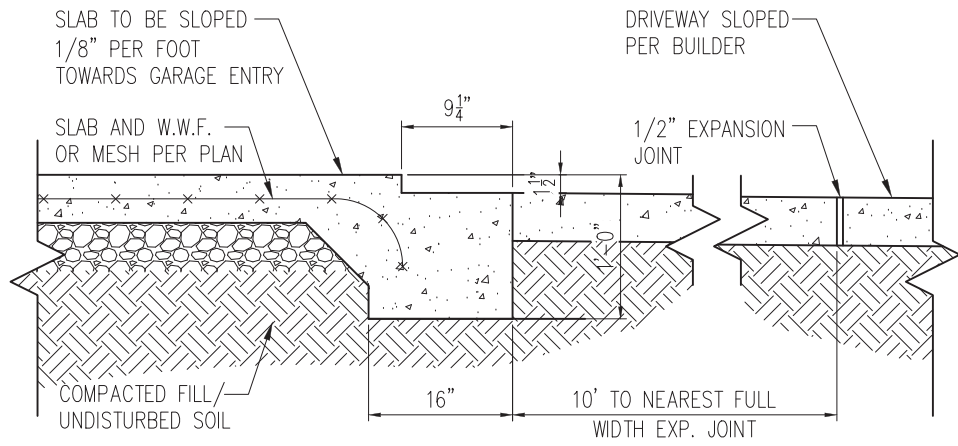

2 SLAB AT GARAGE DOOR
D2m 3/4" = 1'-0"

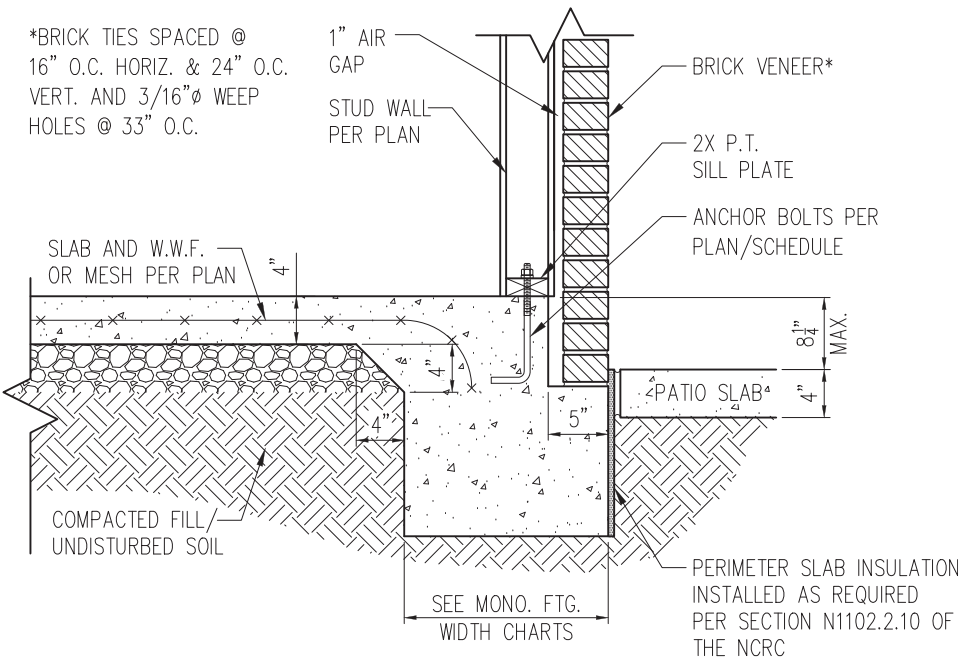

STANDARD - BRICK

4 PATIO SLAB DETAIL W/ BRICK VENEER
D2m 3/4" = 1'-0"

NOTES:

1. REFER TO GENERAL NOTES & SPECIFICATIONS ON SHEET CS2 FOR ADDITIONAL INFORMATION.
2. PROVIDE 6 MIL VAPOR BARRIER UNDER ALL SLABS-ON-GRADE.
3. SEE ARCH. DWGS. FOR ALL TOP OF THE SLAB ELEVATIONS, SLOPES AND DEPRESSIONS.



STRUCTURAL MEMBERS ONLY

SUMMIT
ENGINEERING LABORATORY TESTING
3070 HAMMOND BUSINESS PLACE,
SUITE 171, RALEIGH, NC 27603
OFFICE: 919.380.9991
FAX: 919.380.9993
WWW.SUMMIT-COMPANIES.COM

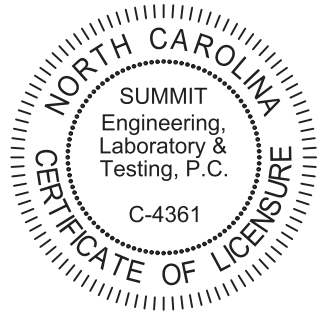

PROJECT
Standard Details
Monolithic Slab Details
CLIENT
Smith Douglas Homes
110 Village Trail, Suite 215
Woodstock, GA 30188

CURRENT DRAWING
DATE: 2/18/20
SCALE: NTS
PROJECT #: 3832
DRAWN BY: LBV
CHECKED BY: WAJ

ORIGINAL DRAWING
NO. DATE PROJECT #
0 1/7/16 3832

REFER TO COVER SHEET FOR A COMPLETE LIST OF REVISIONS

SHEET
D2m

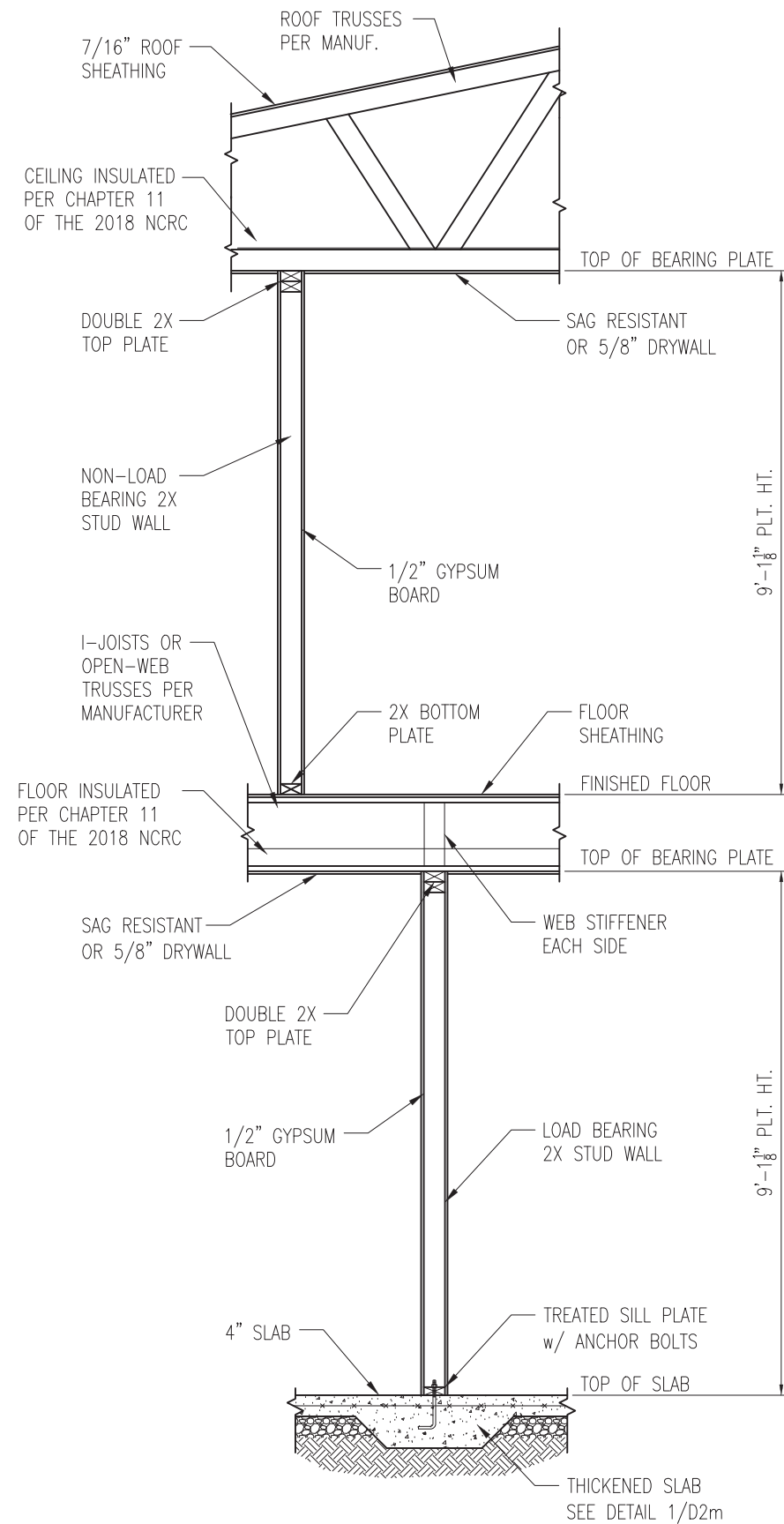

1 TYP. INTERIOR LOAD BEARING WALL SECTION
 D3m 3/4" = 1'-0"

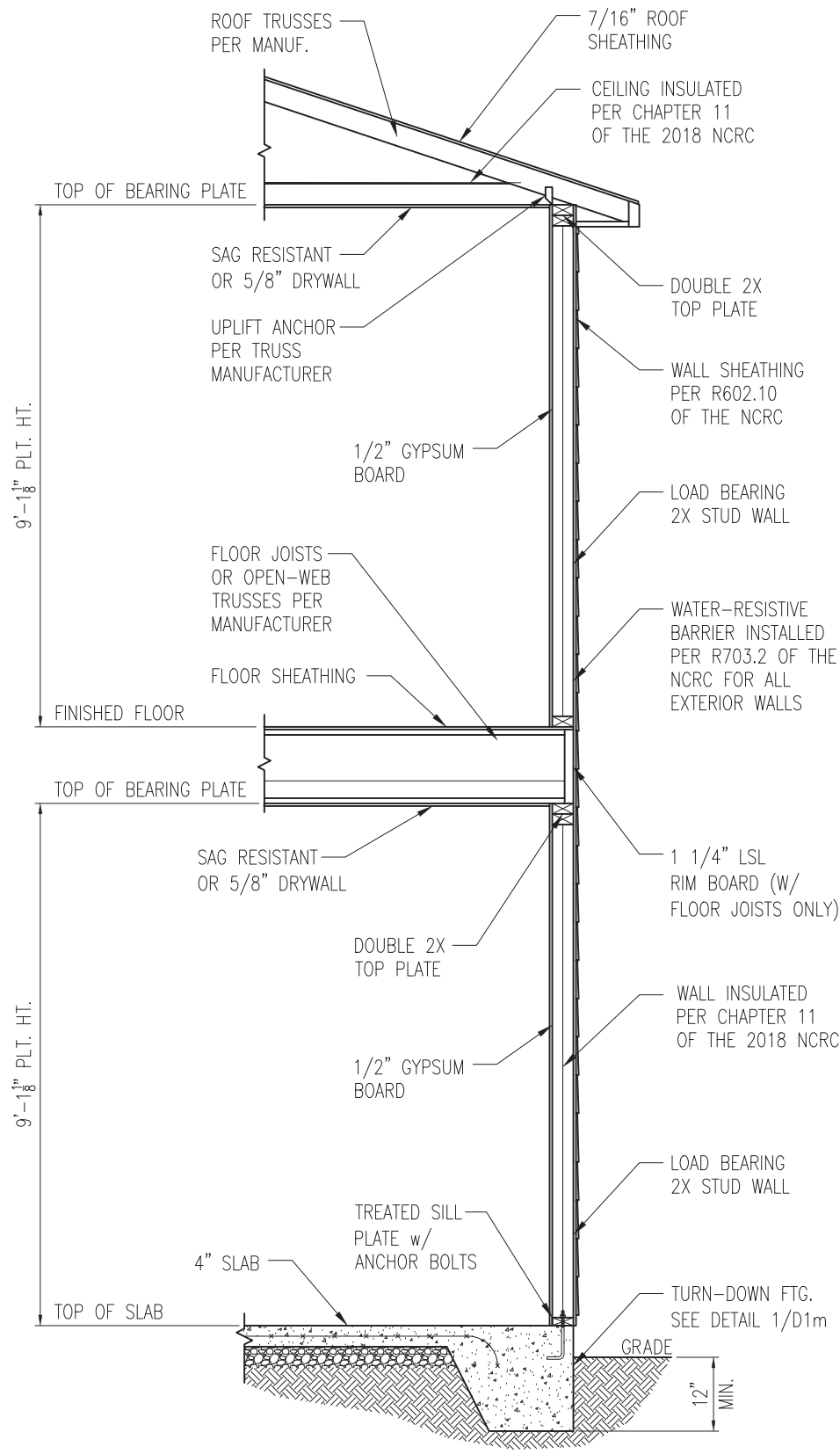

2 TYP. EXTERIOR LOAD BEARING WALL SECTION
 D3m 3/4" = 1'-0"
 -SIMILAR w/ BRICK AND STONE
 -BRICK TIES SPACED @ 16" O.C. HORIZ. & 24" O.C. VERT.
 -MIN. 3/16" Ø WEEP HOLES @ 33" O.C.

- NOTES:
1. REFER TO GENERAL NOTES & SPECIFICATIONS ON SHEET CS2 FOR ADDITIONAL INFORMATION.
 2. PROVIDE 6 MIL VAPOR BARRIER UNDER ALL SLABS-ON-GRADE.
 3. SEE ARCH. DWGS. FOR ALL TOP OF THE SLAB ELEVATIONS, SLOPES AND DEPRESSIONS.



STRUCTURAL MEMBERS ONLY

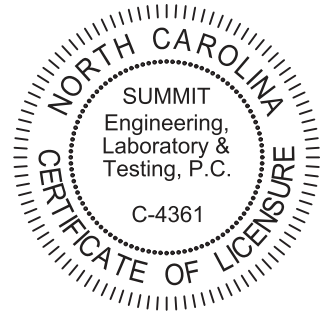

PROJECT
Standard Details
Monolithic Slab Details
 CLIENT
Smith Douglas Homes
 110 Village Trail, Suite 215
 Woodstock, GA 30188

CURRENT DRAWING
 DATE: 2/18/20
 SCALE: NTS
 PROJECT #: 3832
 DRAWN BY: LBV
 CHECKED BY: WAJ

ORIGINAL DRAWING
 NO. DATE PROJECT #
 0 1/7/16 3832

REFER TO COVER SHEET FOR A COMPLETE LIST OF REVISIONS

SHEET
D3m

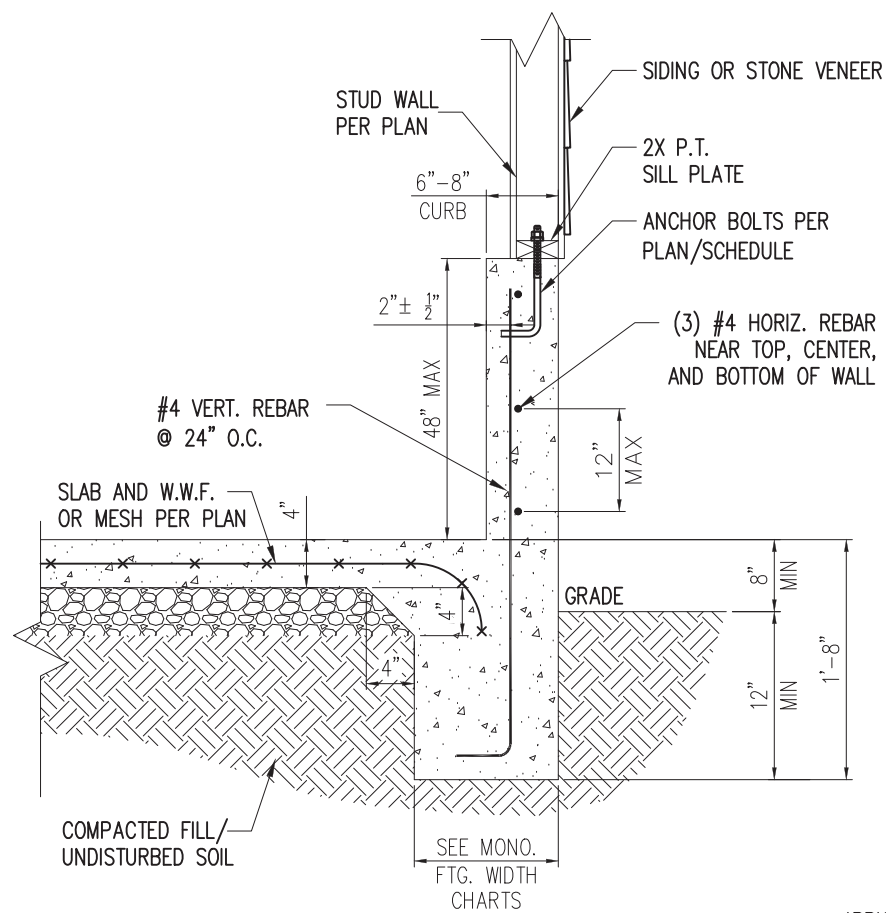

STANDARD - SIDING/STONE

1 EXTENDED GARAGE CURB DETAIL
D4m NTS

*BRICK TIES SPACED @
16" O.C. HORIZ. & 24" O.C.
VERT. AND 3/16" Ø WEEP
HOLES @ 33" O.C.

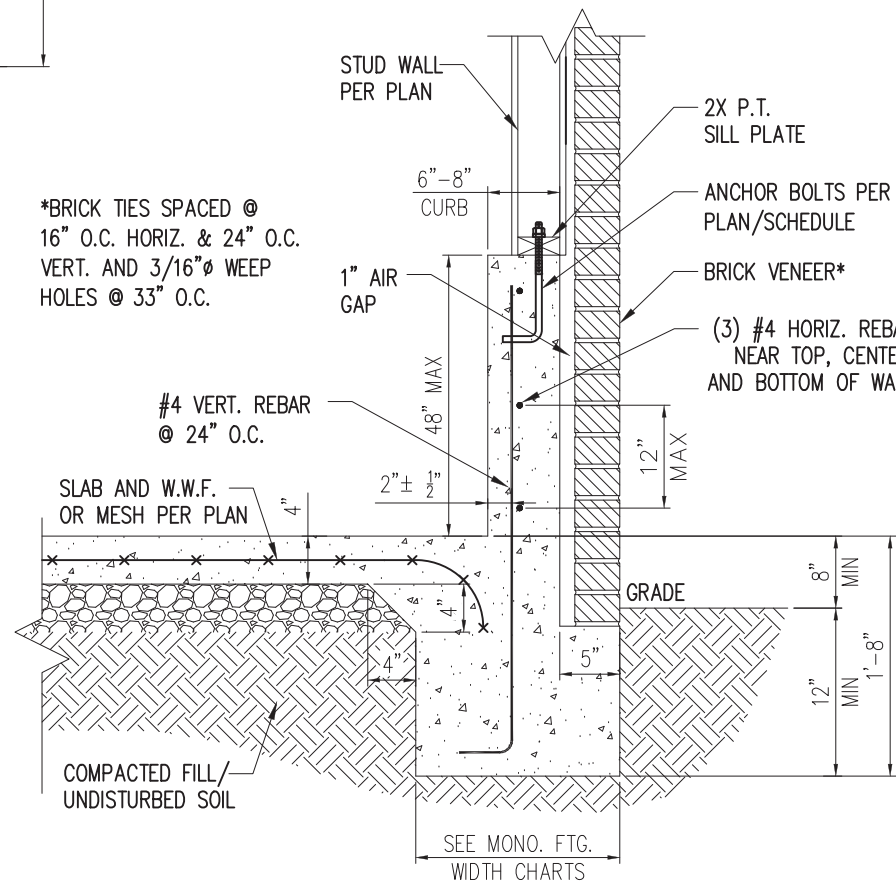

STANDARD - BRICK

3 EXTENDED GARAGE CURB DETAIL
W/ BRICK VENEER
D4m NTS

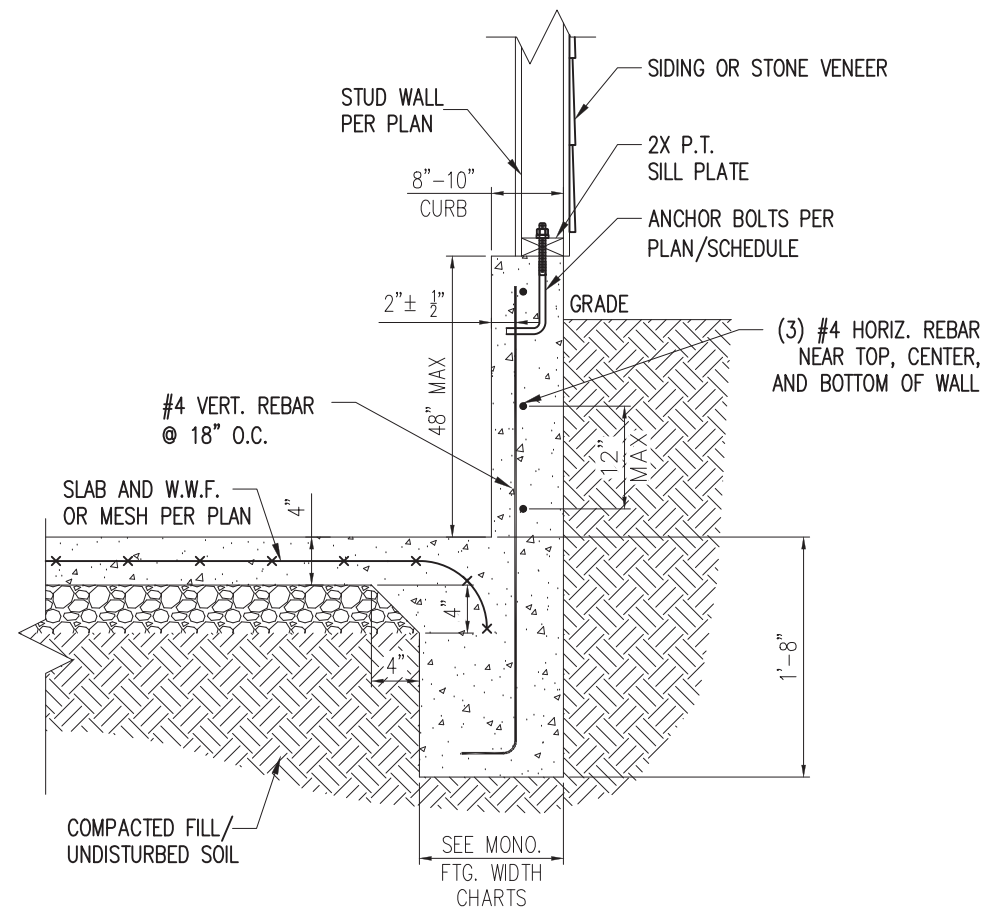

STANDARD - SIDING/STONE

2 EXTENDED GARAGE CURB DETAIL
W/ UNBALANCED FILL
D4m NTS



STRUCTURAL MEMBERS ONLY

SUMMIT
ENGINEERING LABORATORY TESTING
3070 HAMMOND BUSINESS PLACE,
SUITE 171, RALEIGH, NC 27603
OFFICE: 919.380.9991
FAX: 919.380.9993
WWW.SUMMIT-COMPANIES.COM

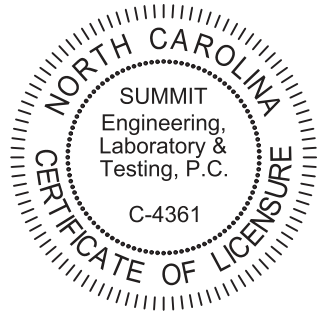

PROJECT
Standard Details
Monolithic Slab Details
CLIENT
Smith Douglas Homes
110 Village Trail, Suite 215
Woodstock, GA 30188

CURRENT DRAWING

DATE: 2/18/20

SCALE: NTS

PROJECT #: 3832

DRAWN BY: LBV

CHECKED BY: WAJ

ORIGINAL DRAWING

NO.	DATE	PROJECT #
0	1/7/16	3832

REFER TO COVER SHEET FOR A
COMPLETE LIST OF REVISIONS

SHEET

D4m

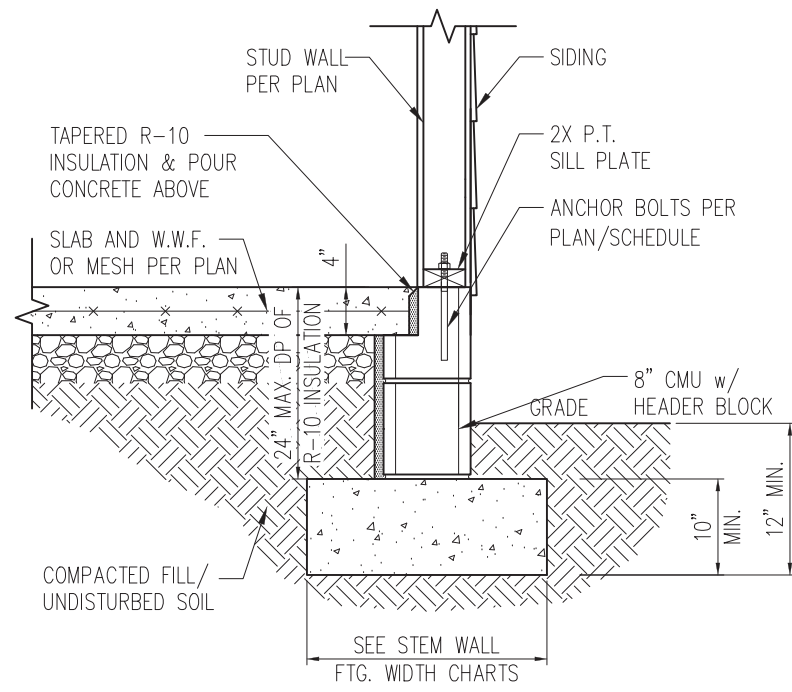

STANDARD - SIDING

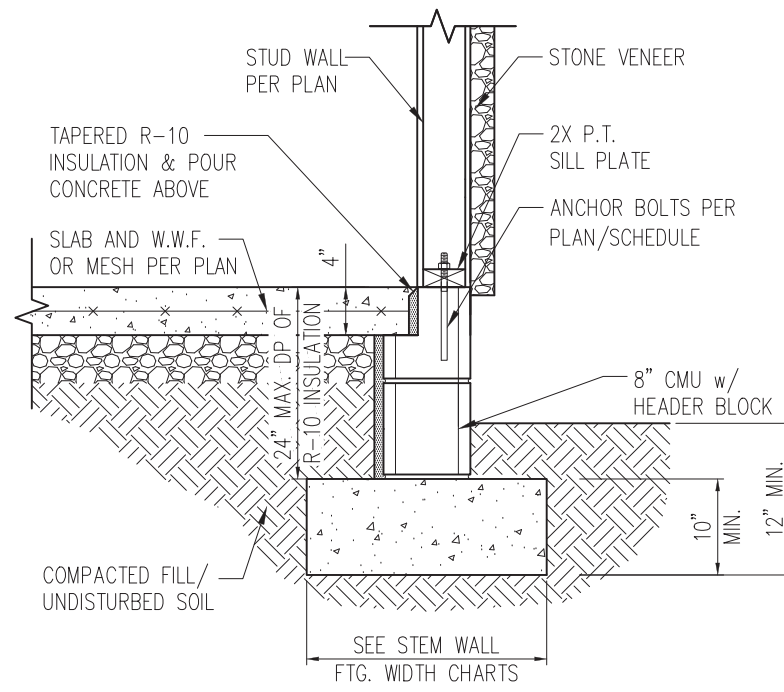

STANDARD - STONE

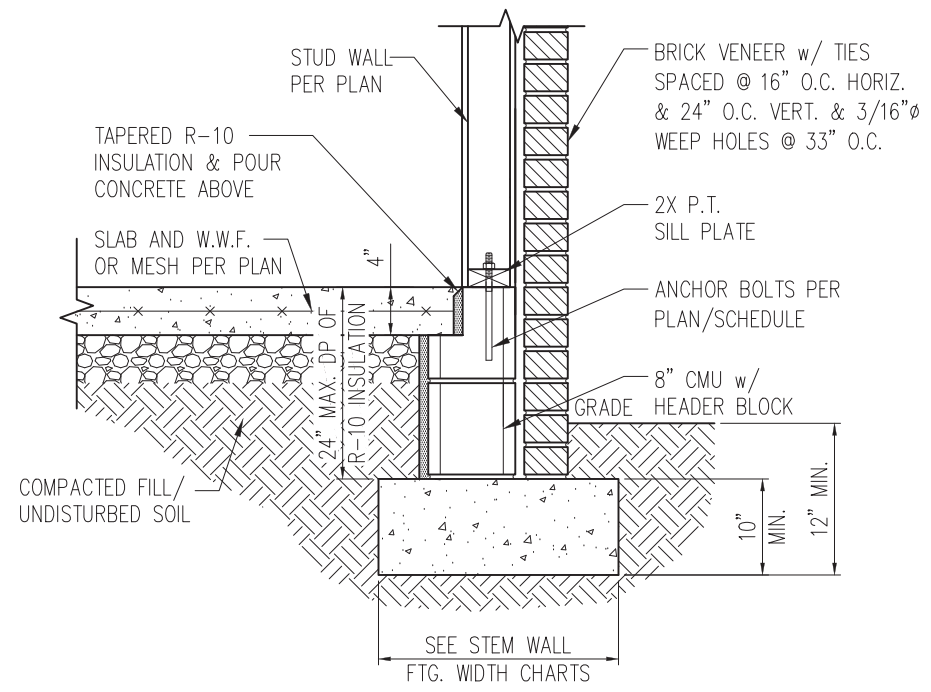

STANDARD - BRICK

1 TYP. STEM WALL DETAIL
D1s 3/4" = 1'-0"

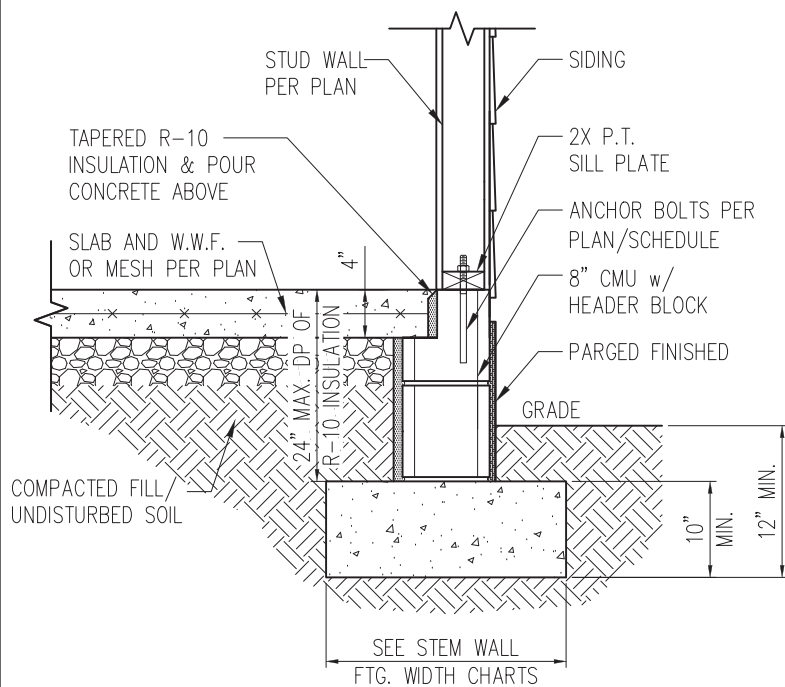

STANDARD - SIDING

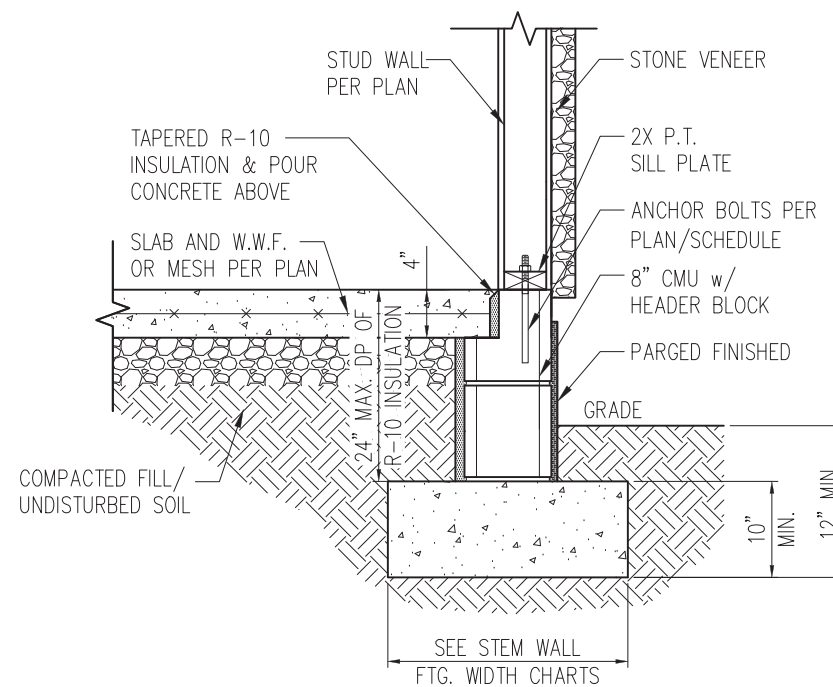

STANDARD - STONE

1a STEM WALL DETAIL w/ PARGED FINISH
D1s 3/4" = 1'-0"

STEM WALL FOOTING WIDTH

# OF STORIES	WIDTH BASED ON SOIL BEARING CAPACITY		
	1500 PSF	2000 PSF	2500 PSF
1 STORY - STD.	16"	16"	16"
1 STORY - BRICK VENEER	21"*	21"*	21"*
2 STORY - STD.	20"	16"	16"
2 STORY - BRICK VENEER	25"*	21"*	21"*

*5" BRICK LEDGE HAS BEEN ADDED TO THE STEM WALL FOOTING WIDTH FOR BRICK SUPPORT

WALL ANCHOR SCHEDULE

TYPE OF ANCHOR	MIN. CONC. EMBEDMENT	SPACING EMBEDMENT	INTERIOR WALL	EXTERIOR WALL
1/2" A307 BOLTS w/ STD. 90° BEND	7"	6'-0"	YES	YES
SST - MAS	4"	5'-0"	NO	YES
HILTI KWIK BOLT KBI 1/2-2-3/4	2-1/4"	6'-0"	YES	NO
1/2" HILTI THREADED ROD w/ HIT HY150 ADHESIVE	7"	6'-0"	YES	YES

NOTE: INSTALL ALL ANCHORS 12" MAX. FROM ALL BOTTOM PLATE ENDS AND JOINTS.

NOTES:

- REFER TO GENERAL NOTES & SPECIFICATIONS ON SHEET CS2 FOR ADDITIONAL INFORMATION.
- PROVIDE 6 MIL VAPOR BARRIER UNDER ALL SLABS-ON-GRADE.
- SEE ARCH. DWGS. FOR ALL TOP OF THE SLAB ELEVATIONS, SLOPS AND DEPRESSIONS.

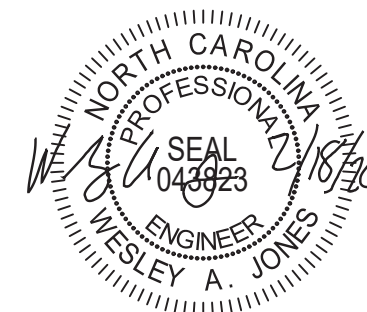

STRUCTURAL MEMBERS ONLY

SUMMIT
ENGINEERING LABORATORY TESTING
3070 HAMMOND BUSINESS PLACE,
SUITE 171, RALEIGH, NC 27603
OFFICE: 919.380.9991
FAX: 919.380.9993
WWW.SUMMIT-COMPANIES.COM

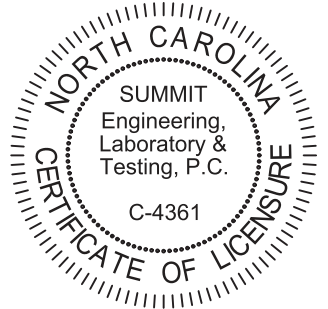

PROJECT
Standard Details
Stemwall Details
CLIENT
Smith Douglas Homes
110 Village Trail, Suite 215
Woodstock, GA 30188

CURRENT DRAWING
DATE: 2/18/20
SCALE: NTS
PROJECT #: 3832
DRAWN BY: LBV
CHECKED BY: WAJ

ORIGINAL DRAWING
NO. DATE PROJECT #
0 1/7/16 3832

REFER TO COVER SHEET FOR A COMPLETE LIST OF REVISIONS

SHEET

D1s

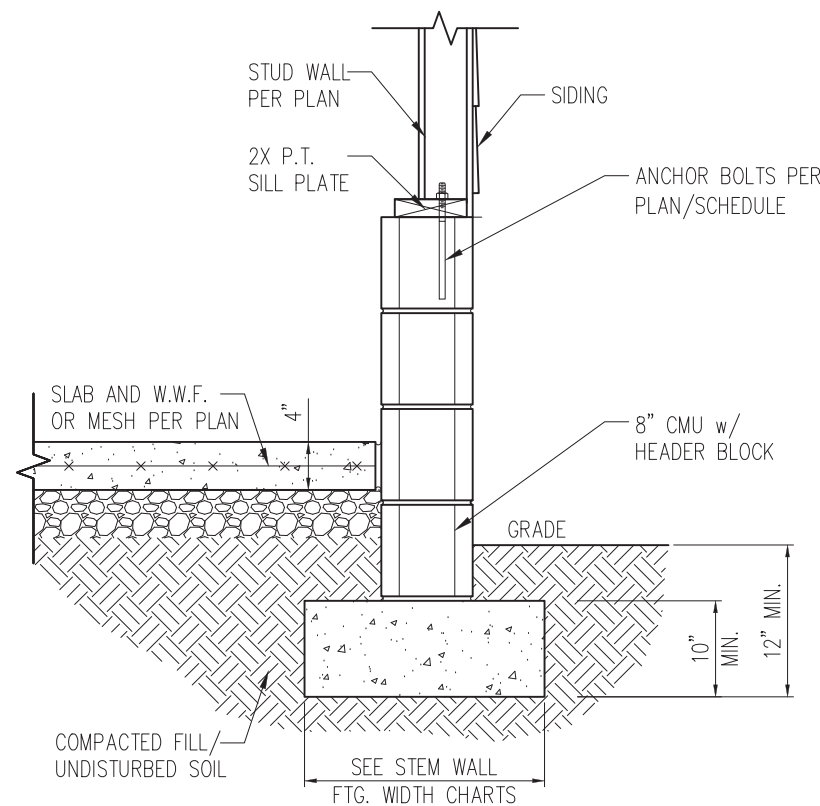

STANDARD - SIDING

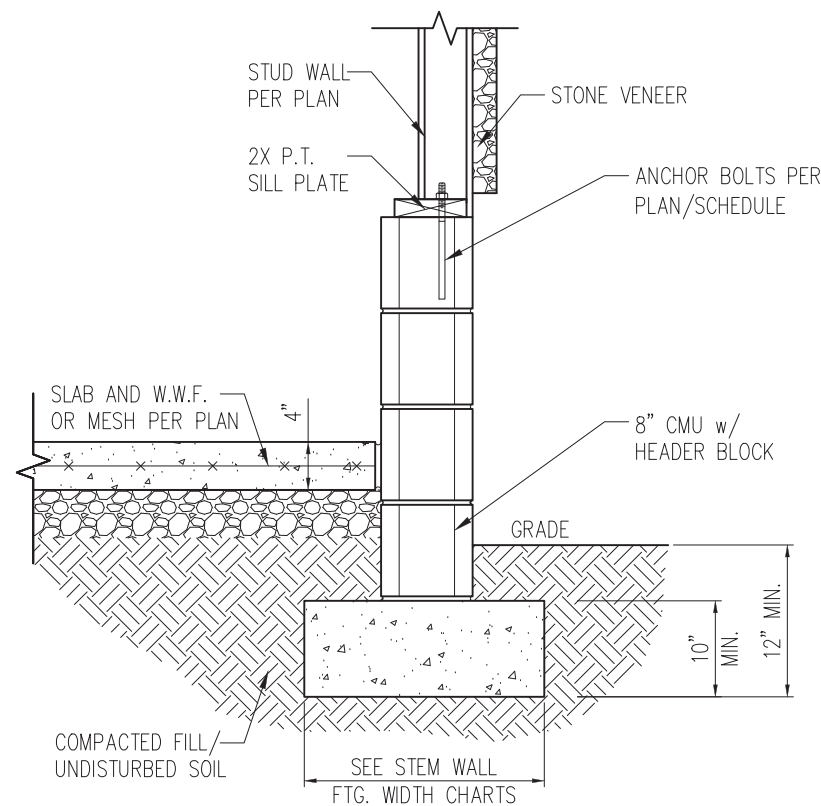

STANDARD - STONE

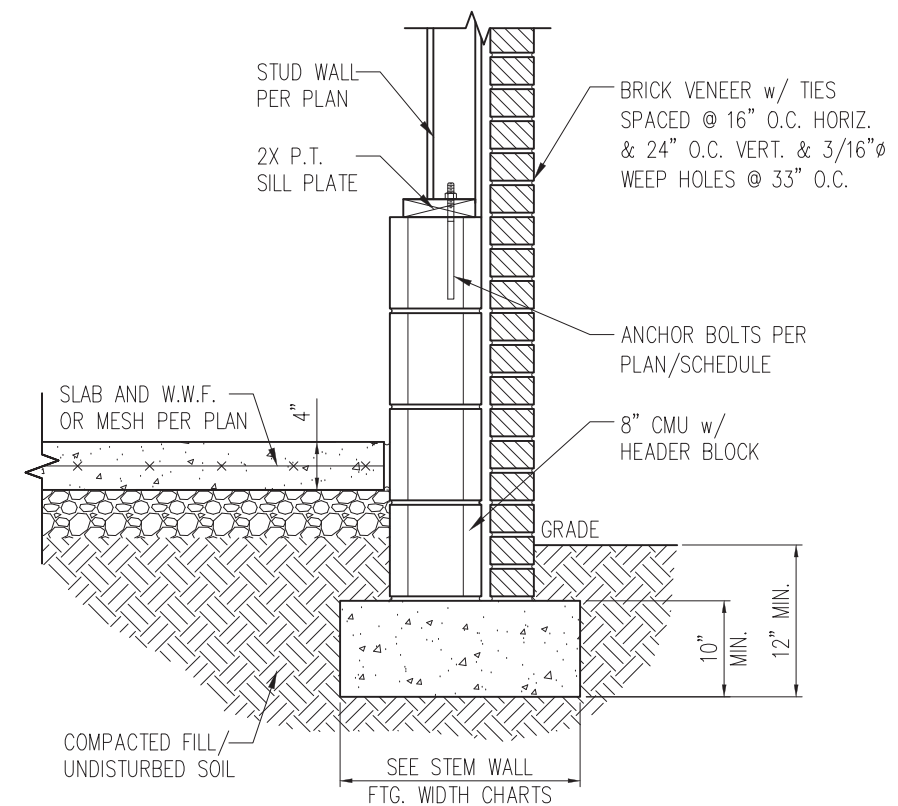

STANDARD - BRICK

1 TYP. GARAGE CURB DETAIL
D2s 3/4" = 1'-0"

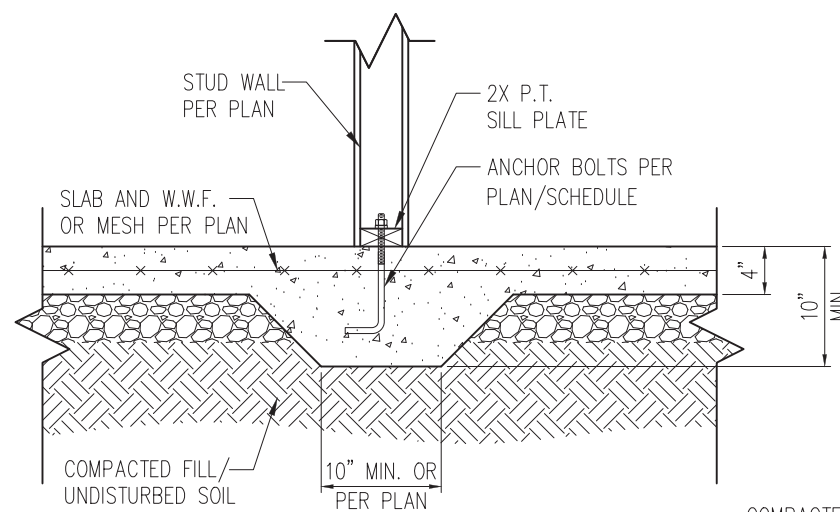

2 TYP. THICKENED SLAB DETAIL
D2s 3/4" = 1'-0"

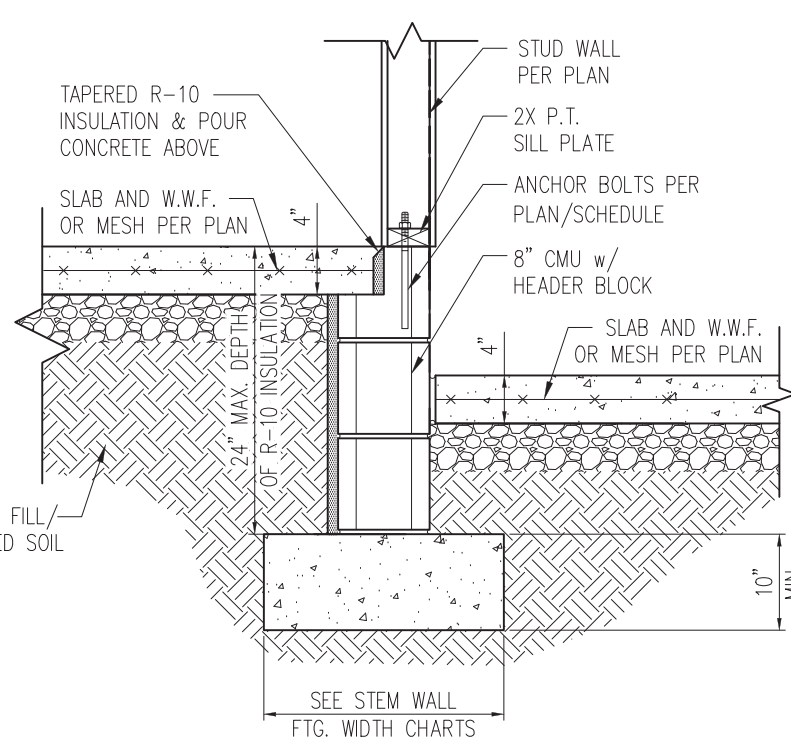

3 HOUSE/GARAGE WALL DETAIL
D2s 3/4" = 1'-0"

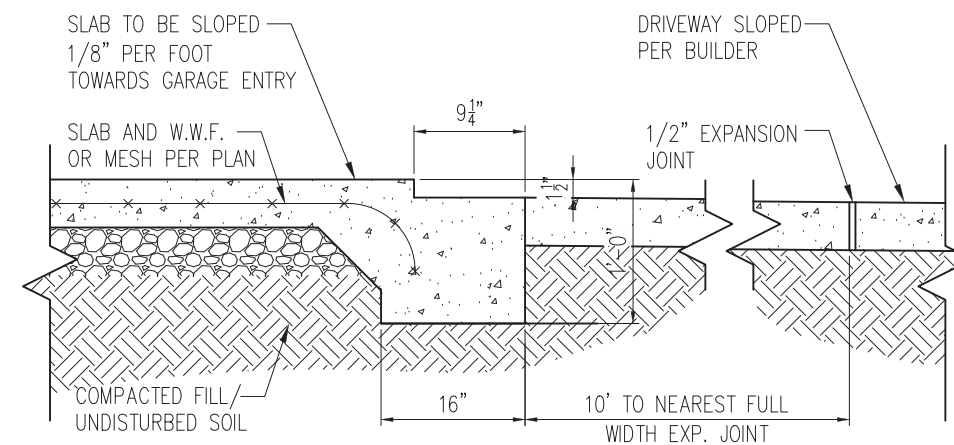

4 SLAB AT GARAGE DOOR
D2s 3/4" = 1'-0"

- NOTES:
- REFER TO GENERAL NOTES & SPECIFICATIONS ON SHEET CS2 FOR ADDITIONAL INFORMATION.
 - PROVIDE 6 MIL VAPOR BARRIER UNDER ALL SLABS-ON-GRADE.
 - SEE ARCH. DWGS. FOR ALL TOP OF THE SLAB ELEVATIONS, SLOPES AND DEPRESSIONS.

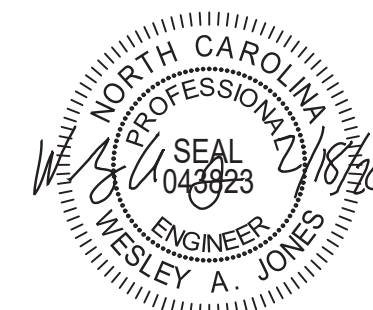

STRUCTURAL MEMBERS ONLY

SUMMIT
ENGINEERING LABORATORY TESTING
3070 HAMMOND BUSINESS PLACE,
SUITE 171, RALEIGH, NC 27603
OFFICE: 919.380.9991
FAX: 919.380.9993
WWW.SUMMIT-COMPANIES.COM

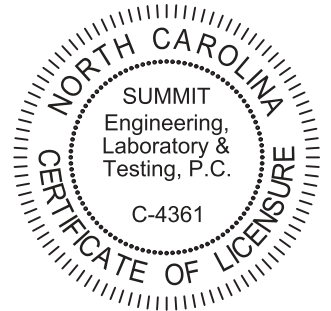

PROJECT
Standard Details
Stemwall Details
CLIENT
Smith Douglas Homes
110 Village Trail, Suite 215
Woodstock, GA 30188

CURRENT DRAWING		
DATE: 2/18/20		
SCALE: NTS		
PROJECT #: 3832		
DRAWN BY: LBV		
CHECKED BY: WAJ		
ORIGINAL DRAWING		
NO.	DATE	PROJECT #
0	1/7/16	3832

REFER TO COVER SHEET FOR A COMPLETE LIST OF REVISIONS

SHEET
D2s

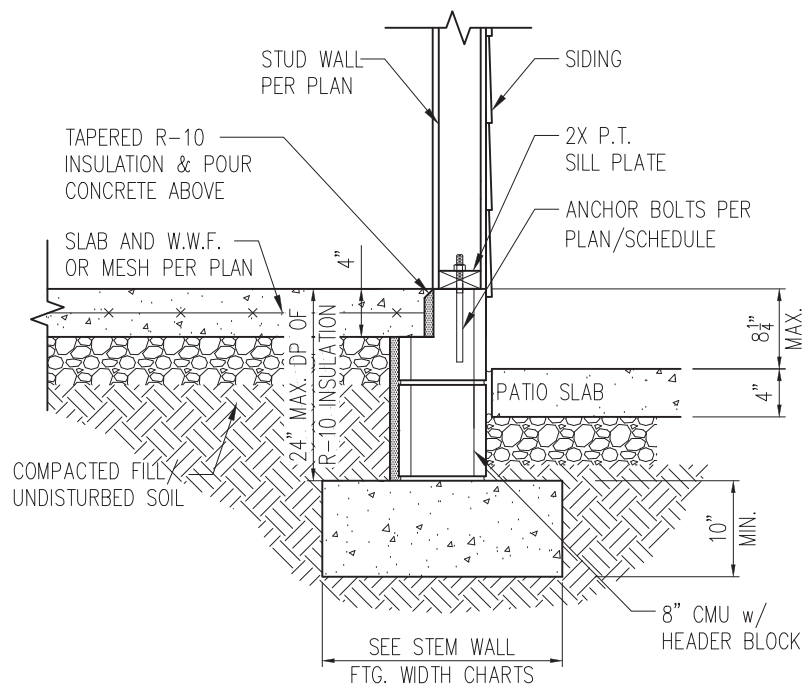

STANDARD - SIDING

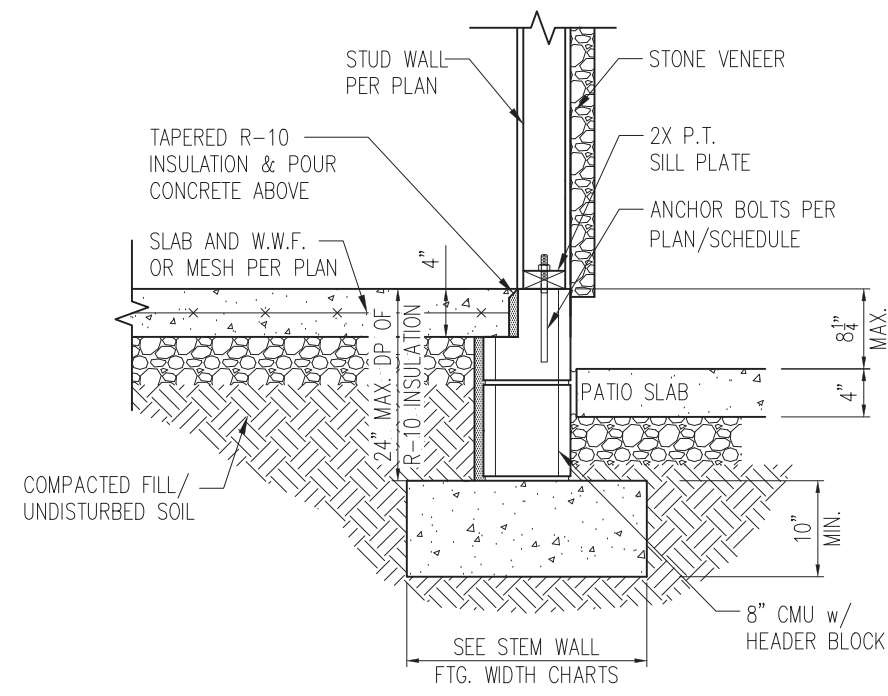

STANDARD - STONE

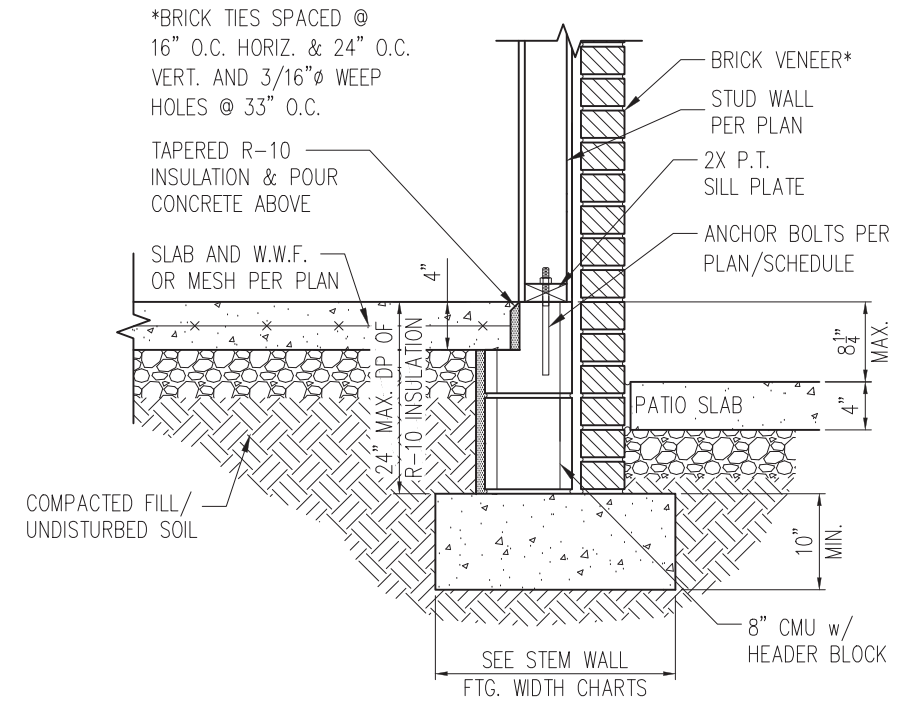

STANDARD - BRICK

1 PORCH SLAB DETAIL
D3s 3/4" = 1'-0"

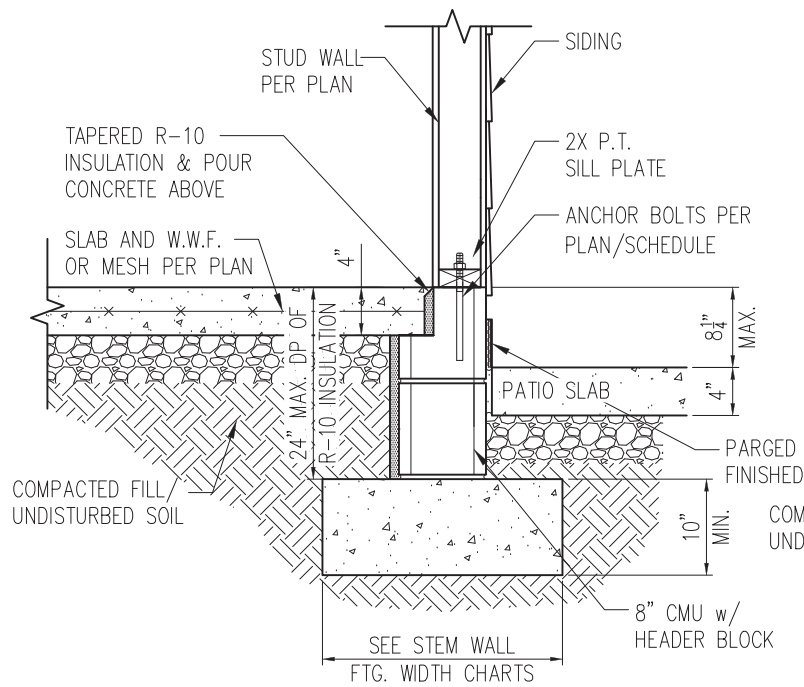

STANDARD - SIDING

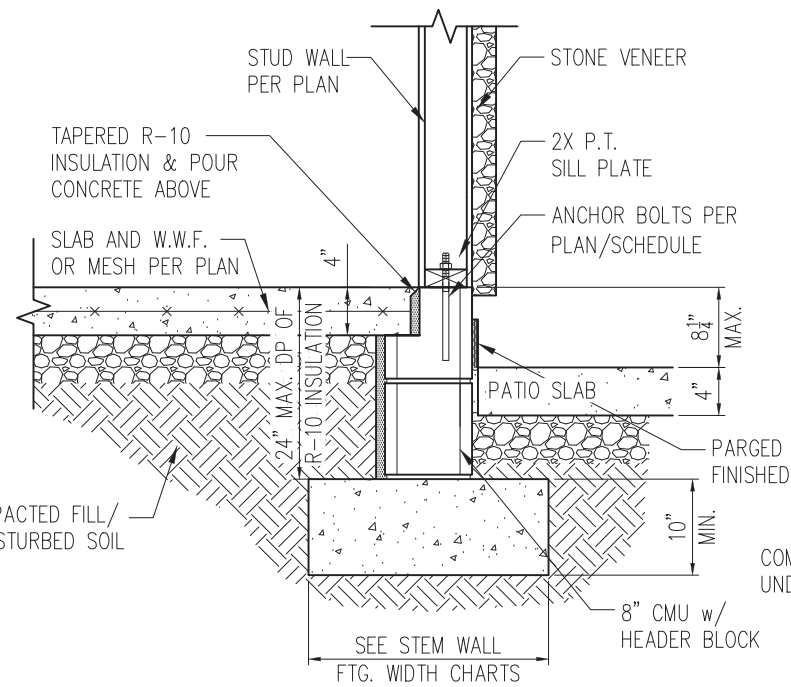

STANDARD - STONE

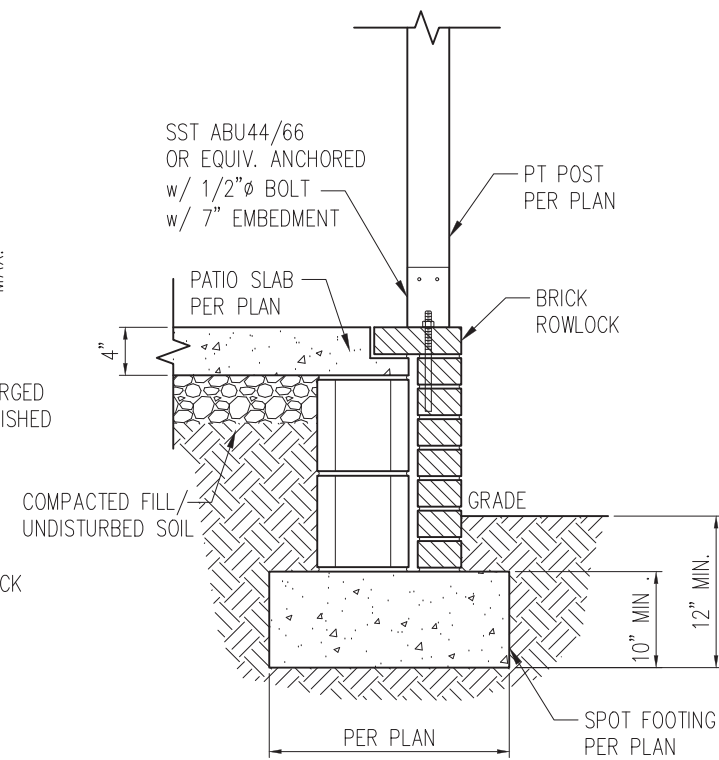

2 COVERED PORCH DETAIL
D3s 3/4" = 1'-0"

- NOTES:
1. REFER TO GENERAL NOTES & SPECIFICATIONS ON SHEET CS2 FOR ADDITIONAL INFORMATION.
 2. PROVIDE 6 MIL VAPOR BARRIER UNDER ALL SLABS-ON-GRADE.
 3. SEE ARCH. DWGS. FOR ALL TOP OF THE SLAB ELEVATIONS, SLOPES AND DEPRESSIONS.

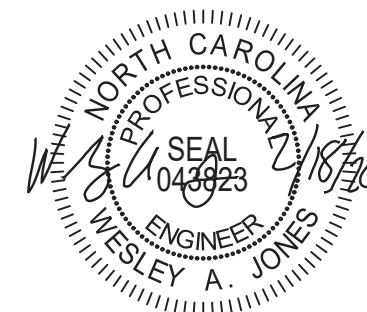

STRUCTURAL MEMBERS ONLY

SUMMIT
ENGINEERING LABORATORY TESTING
3070 HAMMOND BUSINESS PLACE,
SUITE 171, RALEIGH, NC 27603
OFFICE: 919.380.9991
FAX: 919.380.9993
WWW.SUMMIT-COMPANIES.COM

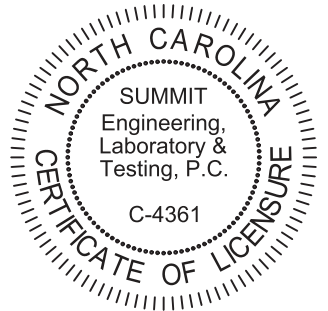

PROJECT
Standard Details
Stemwall Details
CLIENT
Smith Douglas Homes
110 Village Trail, Suite 215
Woodstock, GA 30188

CURRENT DRAWING
DATE: 2/18/20
SCALE: NTS
PROJECT #: 3832
DRAWN BY: LBV
CHECKED BY: WAJ

ORIGINAL DRAWING
NO. DATE PROJECT #
0 1/7/16 3832

REFER TO COVER SHEET FOR A COMPLETE LIST OF REVISIONS

SHEET
D3s

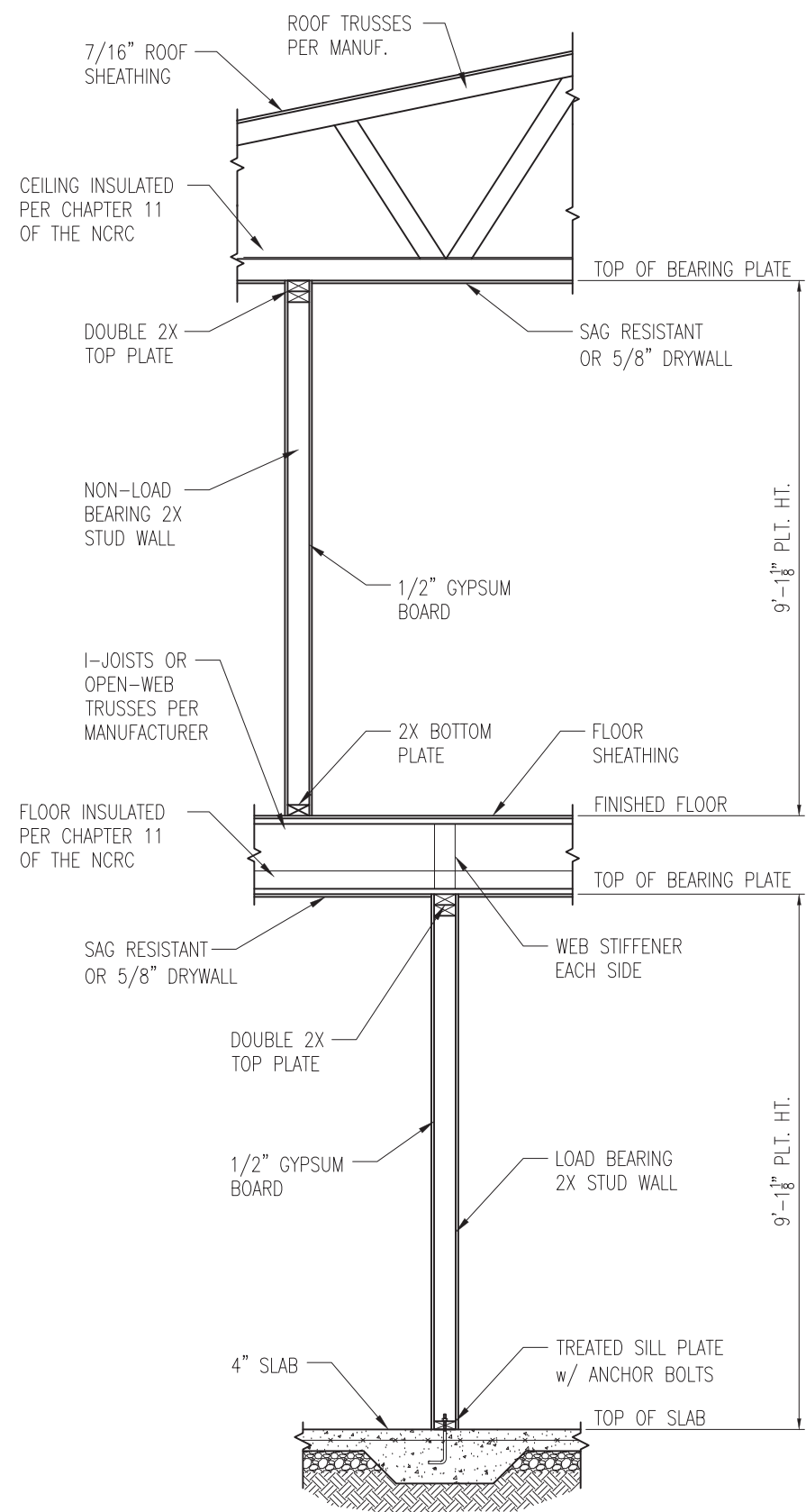

1 TYP. INTERIOR LOAD BEARING WALL SECTION
 D4s 3/4" = 1'-0"

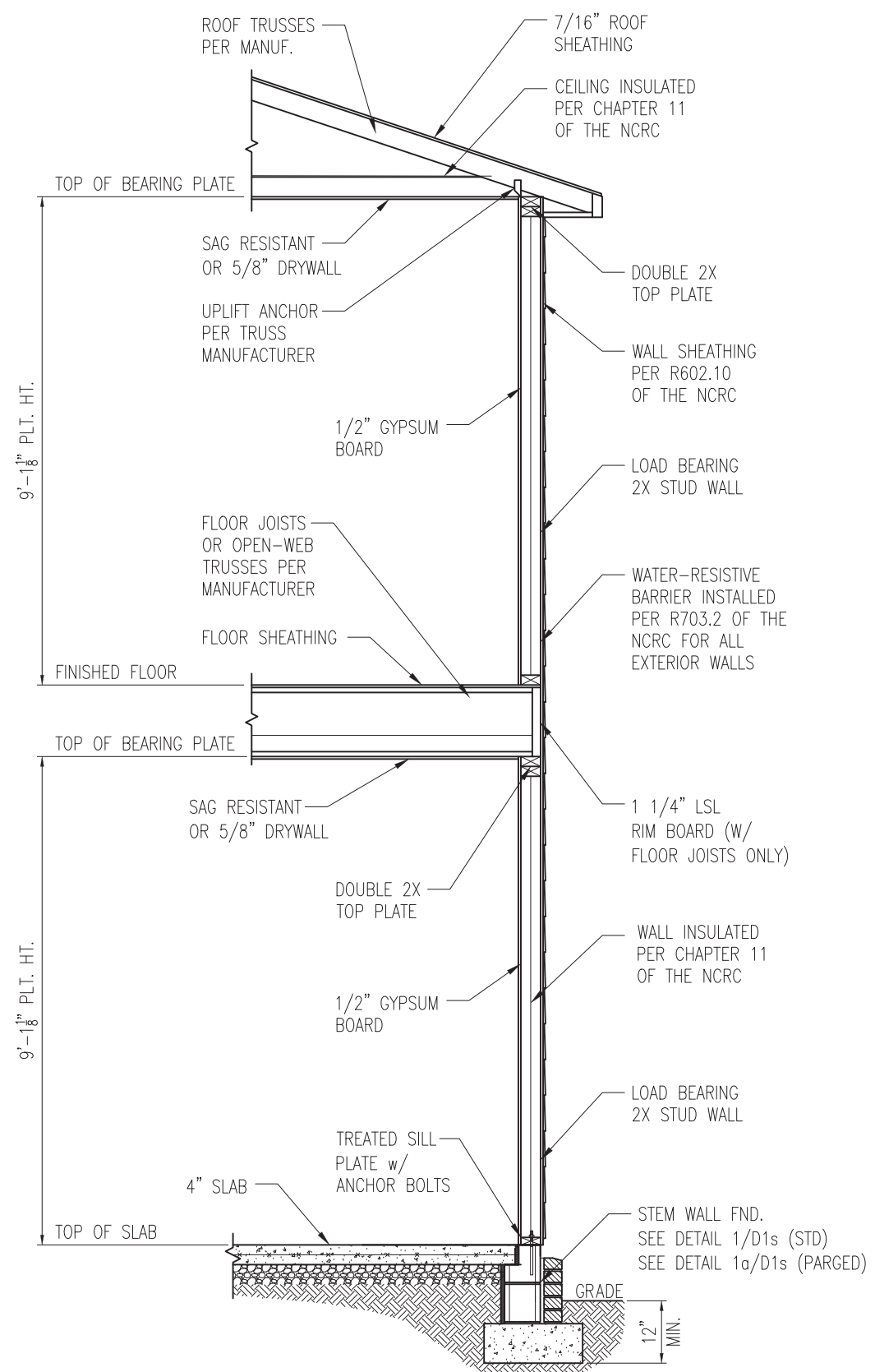

2 TYP. EXTERIOR LOAD BEARING WALL SECTION
 D4s 3/4" = 1'-0"
 -SIMILAR w/ BRICK AND STONE
 -BRICK TIES SPACED @ 16" O.C. HORIZ. & 24" O.C. VERT.
 -MIN. 3/16" WEEP HOLES @ 33" O.C.

- NOTES:
1. REFER TO GENERAL NOTES & SPECIFICATIONS ON SHEET CS2 FOR ADDITIONAL INFORMATION.
 2. PROVIDE 6 MIL VAPOR BARRIER UNDER ALL SLABS-ON-GRADE.
 3. SEE ARCH. DWGS. FOR ALL TOP OF THE SLAB ELEVATIONS, SLOPES AND DEPRESSIONS.



STRUCTURAL MEMBERS ONLY

SUMMIT
 ENGINEERING LABORATORY TESTING
 3070 HAMMOND BUSINESS PLACE,
 SUITE 171, RALEIGH, NC 27603
 OFFICE: 919.380.9991
 FAX: 919.380.9993
 WWW.SUMMIT-COMPANIES.COM

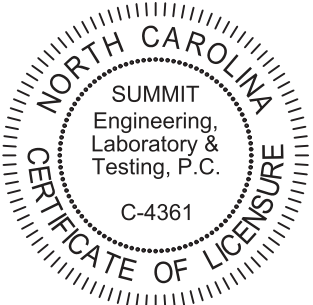

PROJECT
Standard Details
Stemwall Details
 CLIENT
Smith Douglas Homes
 110 Village Trail, Suite 215
 Woodstock, GA 30188

CURRENT DRAWING
 DATE: 2/18/20
 SCALE: NTS
 PROJECT #: 3832
 DRAWN BY: LBV
 CHECKED BY: WAJ

ORIGINAL DRAWING
 NO. DATE PROJECT #
 0 1/7/16 3832

REFER TO COVER SHEET FOR A COMPLETE LIST OF REVISIONS

SHEET
D4s

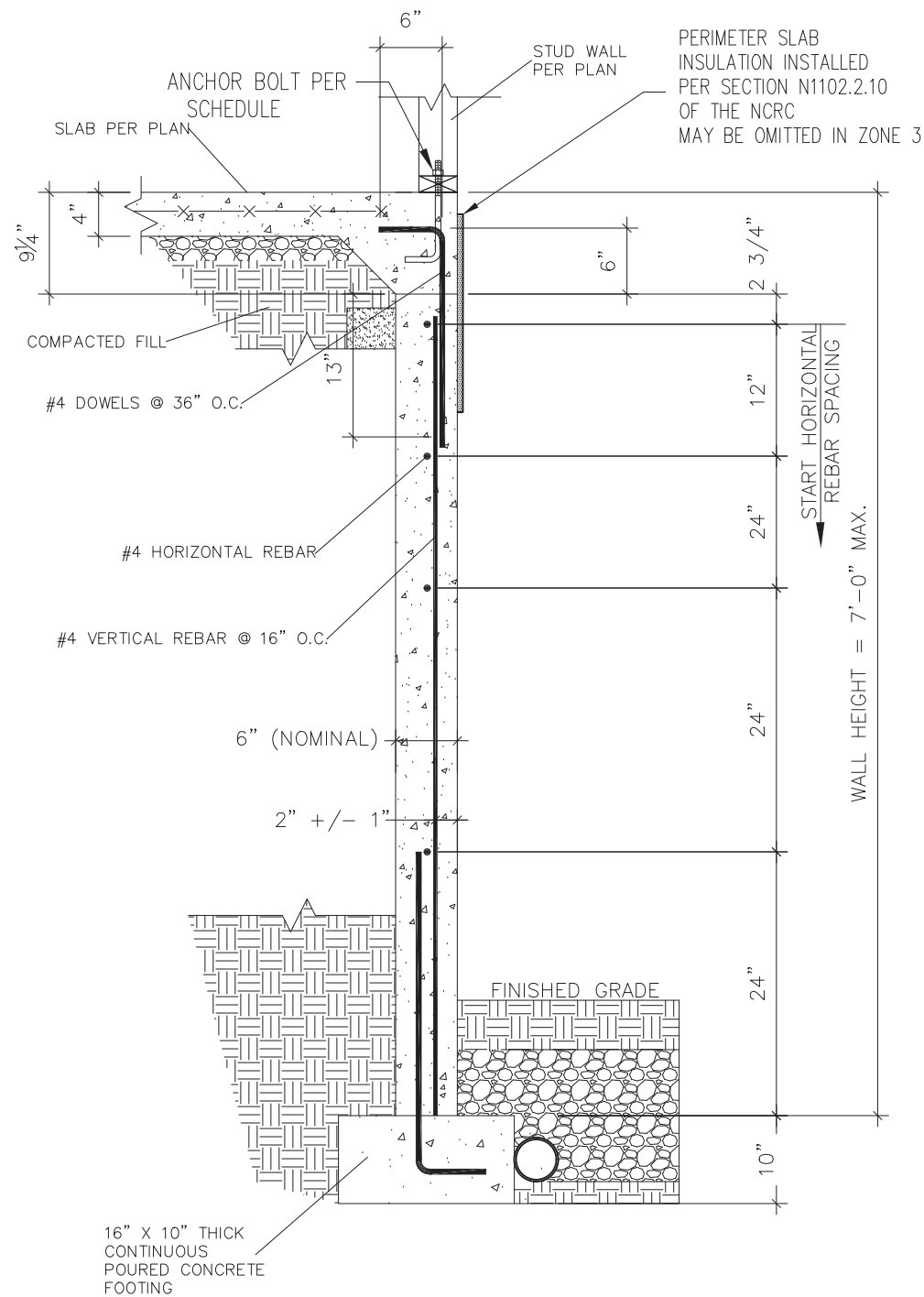

1 SUBWALL FOUNDATION
 D5s 3/4" = 1'-0"

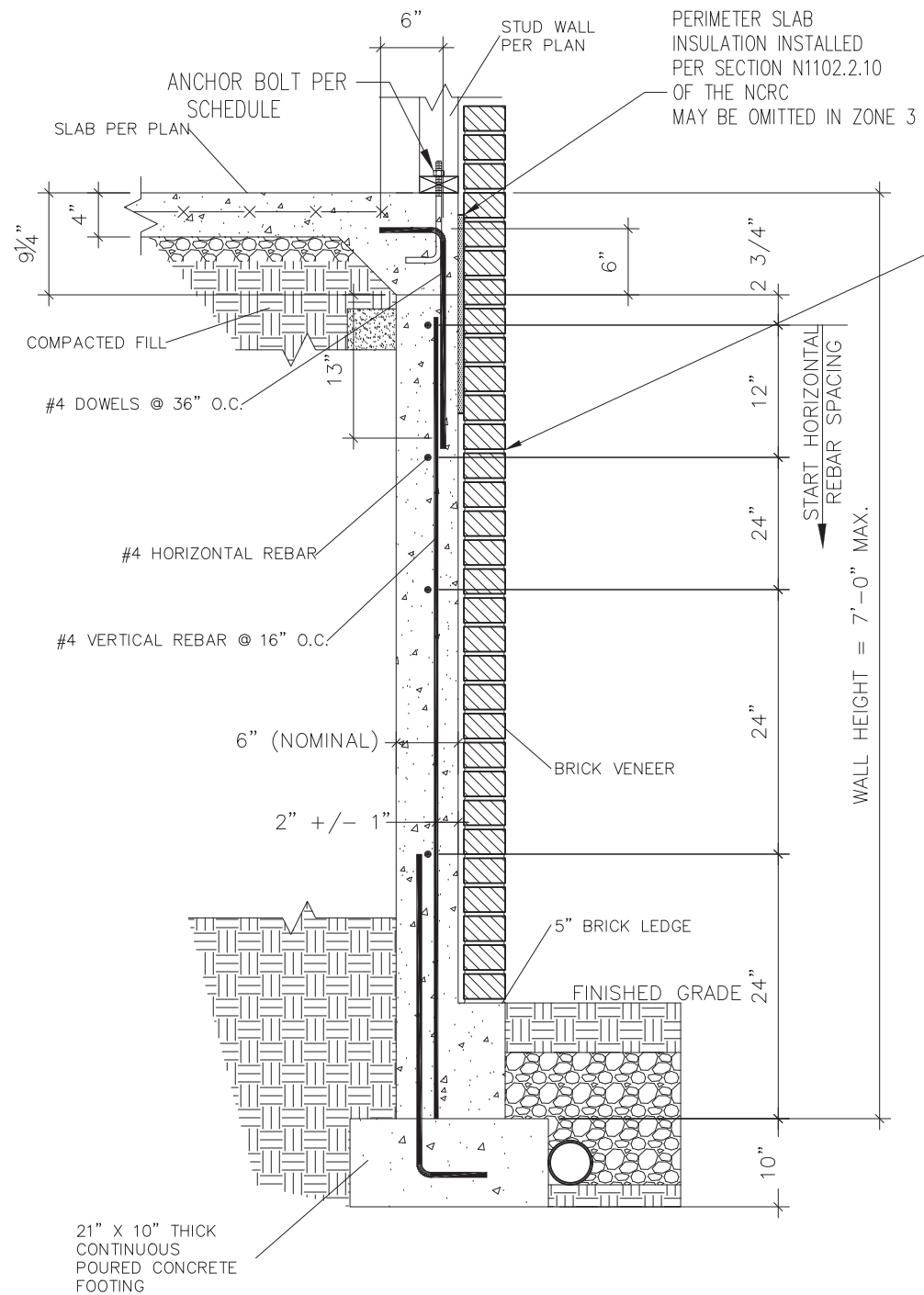

2 SUBWALL FOUNDATION W/ BRICK VENEER
 D5s 3/4" = 1'-0"

PROVIDE LADDER WIRE OR METAL TIES, INSTALLED PER R608.1.2 OF THE 2012 NCRC, AND FULLY GROUT BETWEEN BRICK AND CONCRETE.



STRUCTURAL MEMBERS ONLY

SUMMIT
 ENGINEERING LABORATORY TESTING
 3070 HAMMOND BUSINESS PLACE,
 SUITE 171, RALEIGH, NC 27603
 OFFICE: 919.380.9991
 FAX: 919.380.9993
 WWW.SUMMIT-COMPANIES.COM

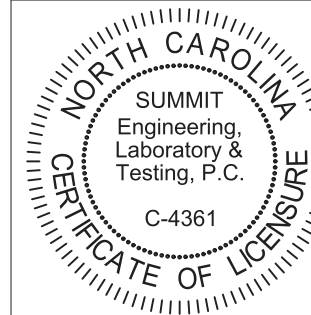

PROJECT
Standard Details
Stemwall Details
 CLIENT
 Smith Douglas Homes
 110 Village Trail, Suite 215
 Woodstock, GA 30188

CURRENT DRAWING
 DATE: 2/18/20
 SCALE: NTS
 PROJECT #: 3832
 DRAWN BY: LBV
 CHECKED BY: WAJ

ORIGINAL DRAWING
 NO. DATE PROJECT #
 0 1/7/16 3832

REFER TO COVER SHEET FOR A COMPLETE LIST OF REVISIONS

SHEET

D5s

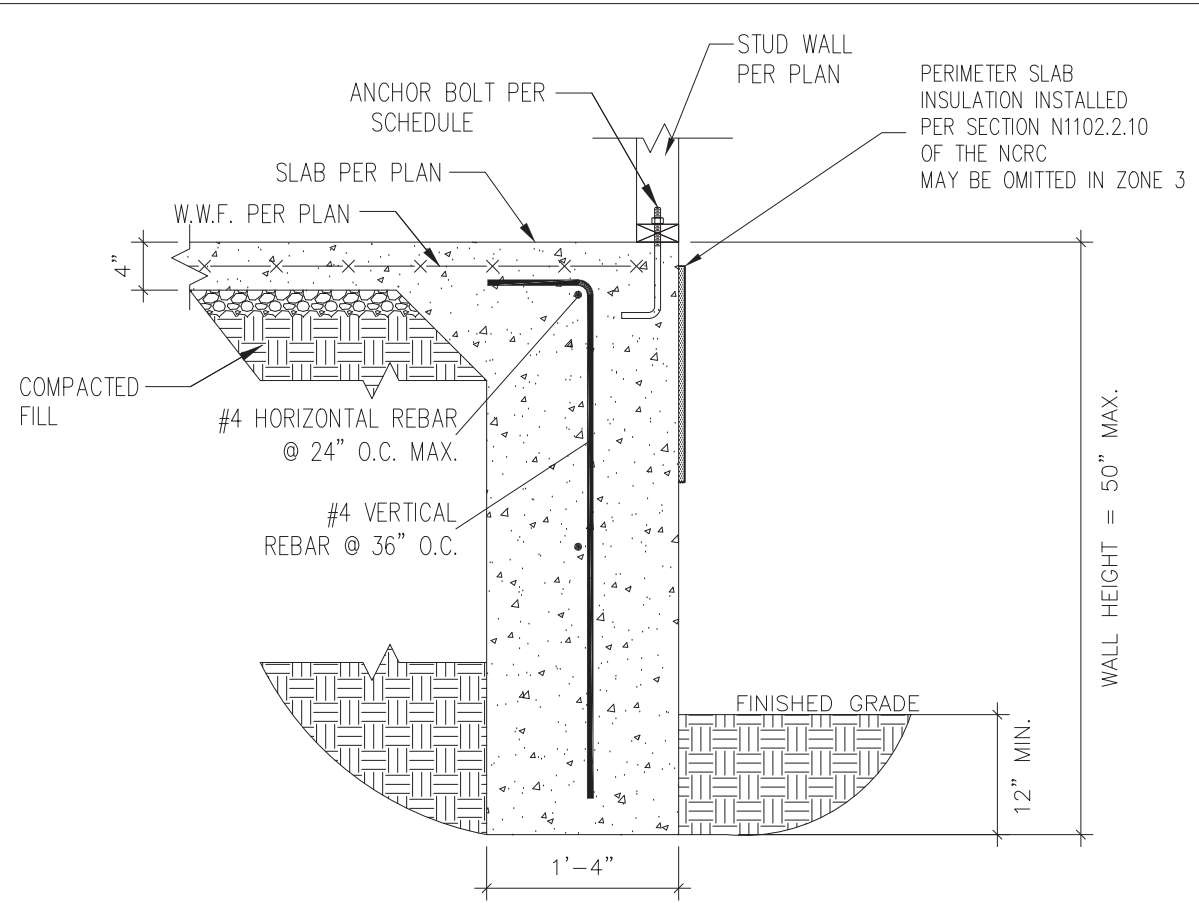

1 TURNDOWN FOUNDATION
 D6s 3/4" = 1'-0"

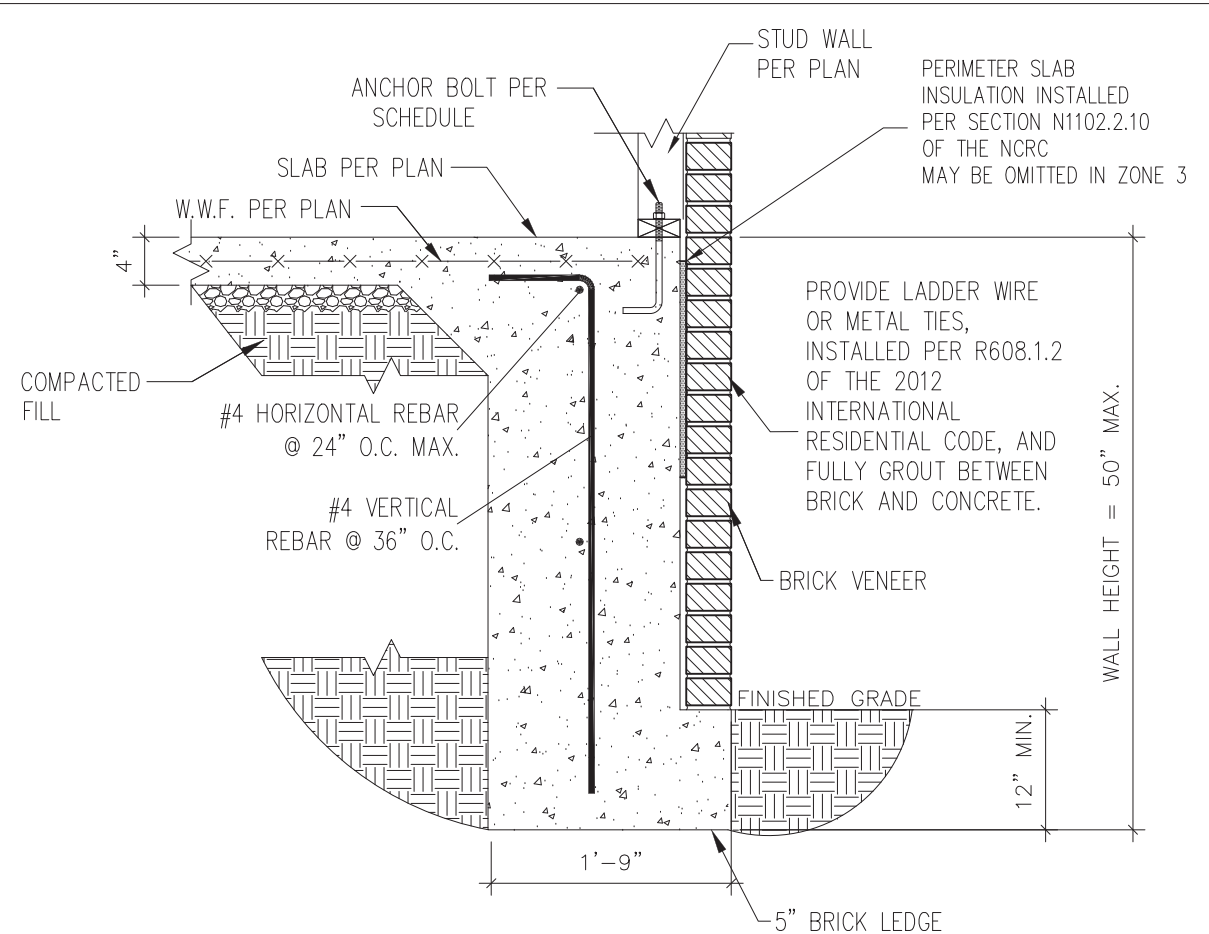

2 TURNDOWN FOUNDATION W/ BRICK VENEER
 D6s 3/4" = 1'-0"

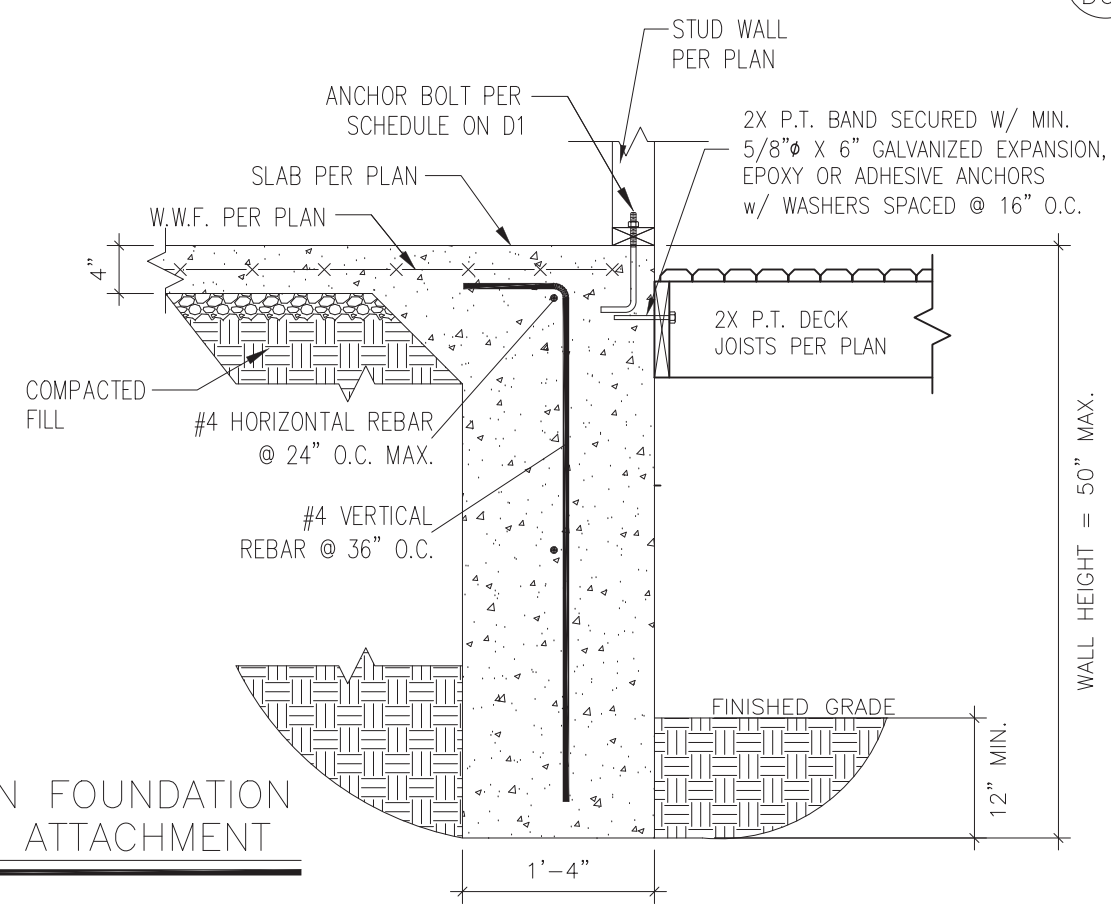

3 TURNDOWN FOUNDATION W/ DECK ATTACHMENT
 D6s 3/4" = 1'-0"



STRUCTURAL MEMBERS ONLY

SUMMIT
 ENGINEERING LABORATORY TESTING
 3070 HAMMOND BUSINESS PLACE,
 SUITE 171, RALEIGH, NC 27603
 OFFICE: 919.380.9991
 FAX: 919.380.9993
 WWW.SUMMIT-COMPANIES.COM

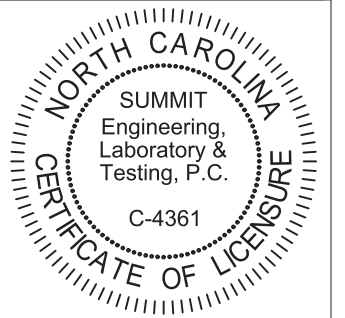

PROJECT
Standard Details
Stemwall Details
 CLIENT
Smith Douglas Homes
 110 Village Trail, Suite 215
 Woodstock, GA 30188

CURRENT DRAWING
 DATE: 2/18/20
 SCALE: NTS
 PROJECT #: 3832
 DRAWN BY: LBV
 CHECKED BY: WAJ

NO.	DATE	PROJECT #
0	1/7/16	3832

REFER TO COVER SHEET FOR A COMPLETE LIST OF REVISIONS

SHEET
D6s

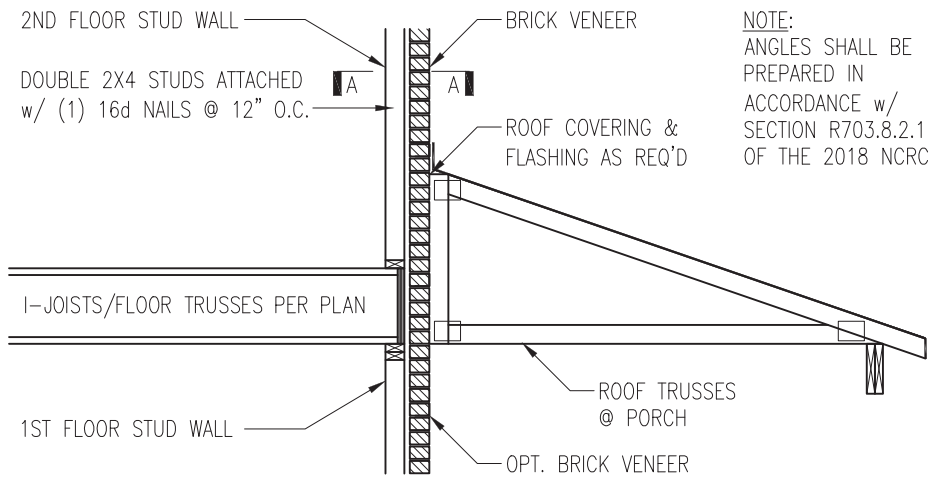

NOTE:
ANGLES SHALL BE PREPARED IN ACCORDANCE w/ SECTION R703.8.2.1 OF THE 2018 NCR

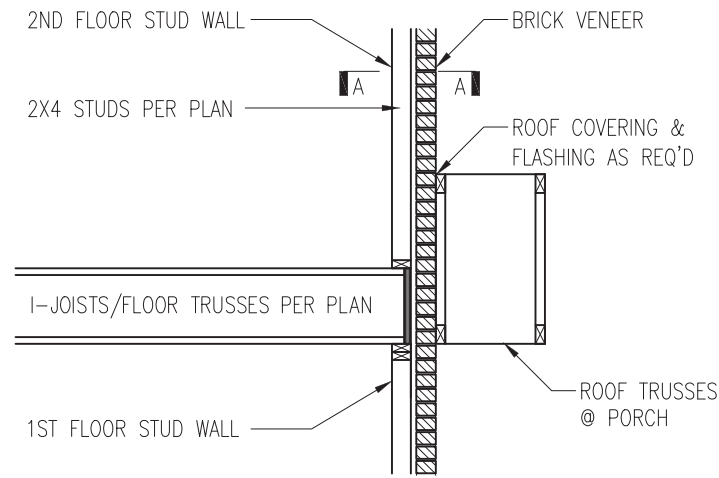

TRUSSES PERPENDICULAR TO STUD WALL

TRUSSES PARALLEL TO STUD WALL w/ CONTINUOUS BRICK VENEER

1 BRICK SUPPORT ABOVE STORAGE/PORCH ROOF DETAIL
D5f NTS

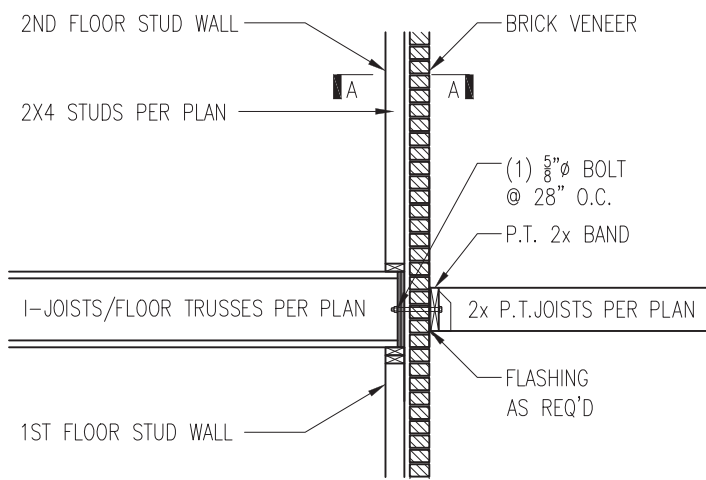

3 BALCONY JOIST ATTACHMENT
D5f NTS

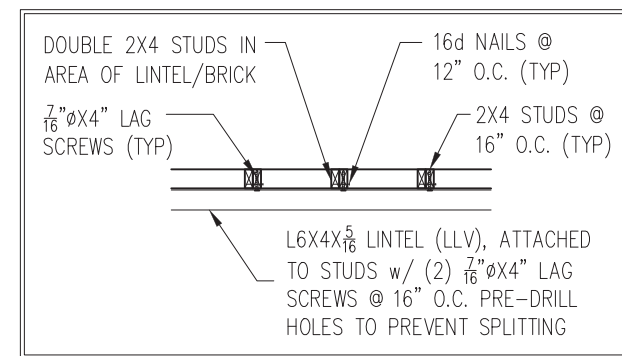

SECTION A-A
NTS

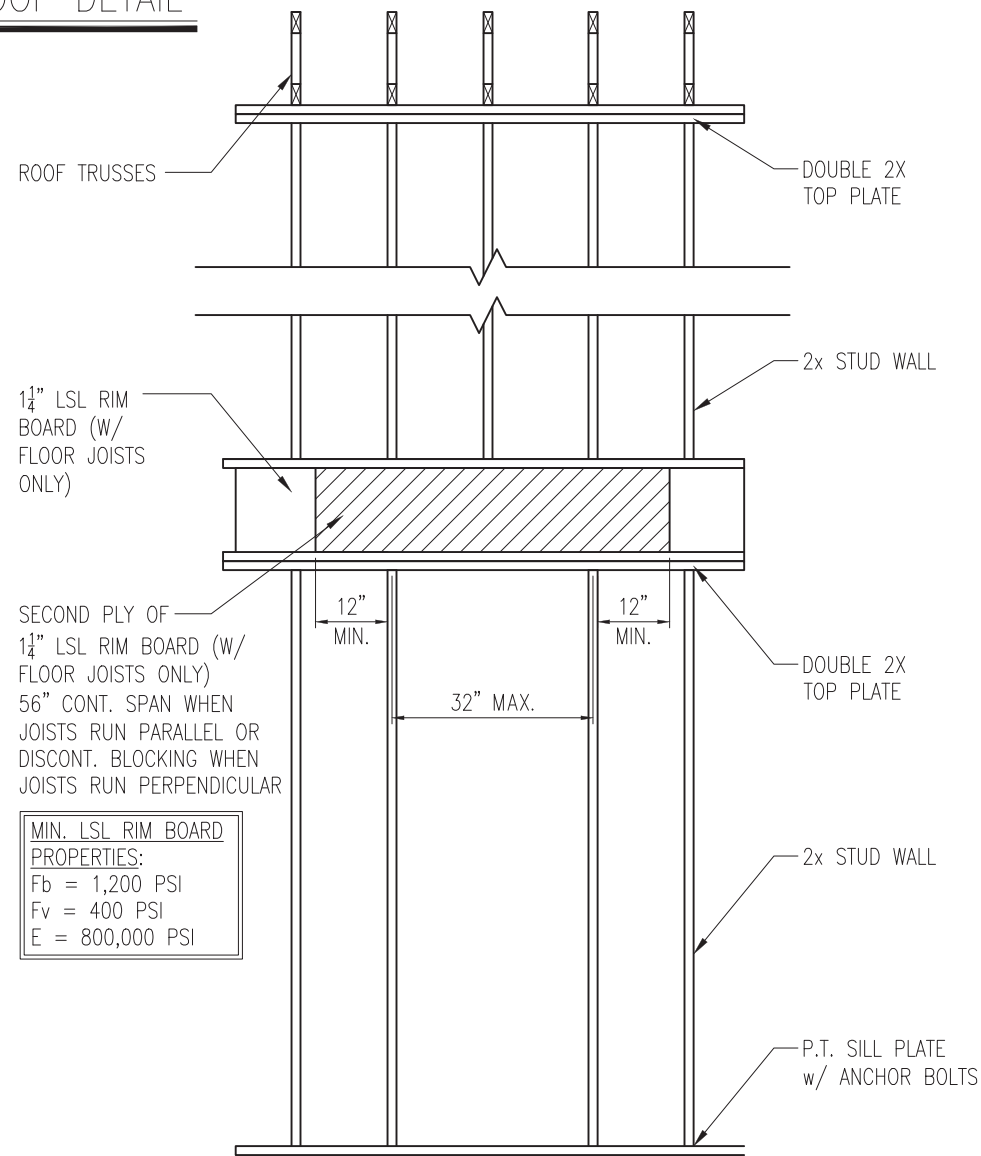

SECOND PLY OF 1 1/4\"/>

MIN. LSL RIM BOARD
PROPERTIES:
Fb = 1,200 PSI
Fv = 400 PSI
E = 800,000 PSI

4 TYP. RANGE VENT FRAMING
D5f VENTED TO EXTERIOR WALL

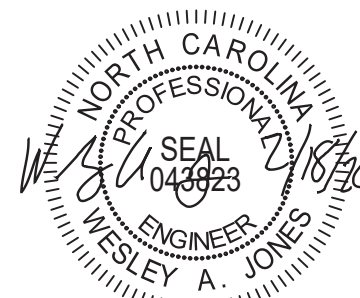

STRUCTURAL MEMBERS ONLY

SUMMIT
ENGINEERING LABORATORY TESTING
3070 HAMMOND BUSINESS PLACE,
SUITE 171, RALEIGH, NC 27603
OFFICE: 919.380.9991
FAX: 919.380.9993
WWW.SUMMIT-COMPANIES.COM

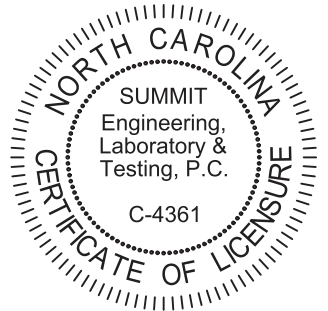

PROJECT
Standard Details
Framing Details
CLIENT
Smith Douglas Homes
110 Village Trail, Suite 215
Woodstock, GA 30188

CURRENT DRAWING
DATE: 2/18/20
SCALE: NTS
PROJECT #: 3832
DRAWN BY: LBV
CHECKED BY: WAJ

ORIGINAL DRAWING
NO. DATE PROJECT #
0 1/7/16 3832

REFER TO COVER SHEET FOR A COMPLETE LIST OF REVISIONS

SHEET
D5f

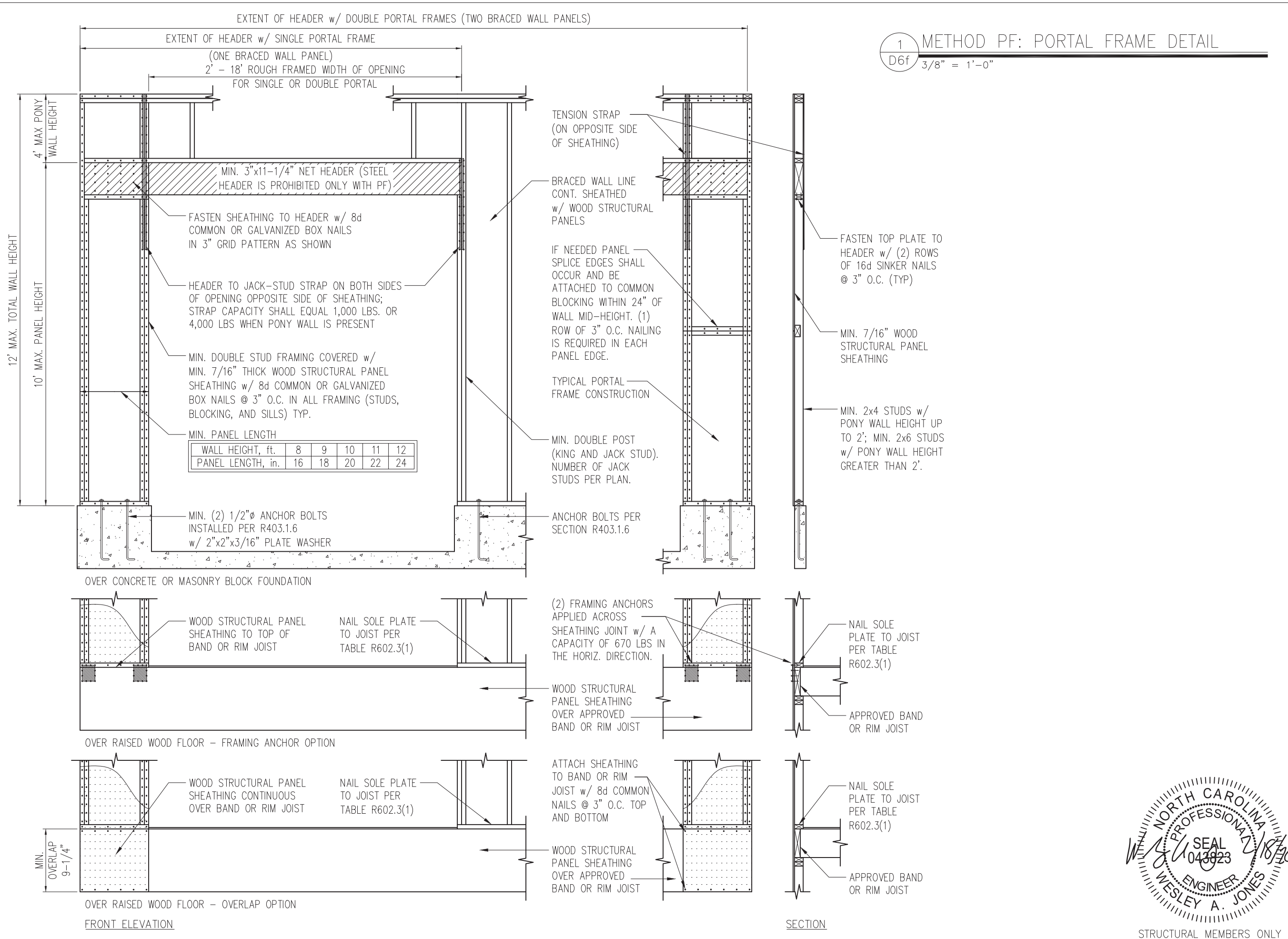

1 METHOD PF: PORTAL FRAME DETAIL
D6f 3/8" = 1'-0"

SUMMIT
ENGINEERING LABORATORY TESTING
3070 HAMMOND BUSINESS PLACE,
SUITE 171, RALEIGH, NC 27603
OFFICE: 919.380.9991
FAX: 919.380.9993
WWW.SUMMIT-COMPANIES.COM

NORTH CAROLINA
SUMMIT
Engineering,
Laboratory &
Testing, P.C.
C-4361
CERTIFICATE OF LICENSURE

PROJECT
Standard Details
Framing Details - Bracing

CLIENT
Smith Douglas Homes
110 Village Trail, Suite 215
Woodstock, GA 30188

CURRENT DRAWING
DATE: 2/18/20
SCALE: NTS
PROJECT #: 3832
DRAWN BY: LBV
CHECKED BY: WAJ

ORIGINAL DRAWING
NO. DATE PROJECT #
0 1/7/16 3832

REFER TO COVER SHEET FOR A COMPLETE LIST OF REVISIONS

NORTH CAROLINA
PROFESSIONAL
ENGINEER
WESLEY A. JONES
SEAL 043823

SHEET
D6f
STRUCTURAL MEMBERS ONLY

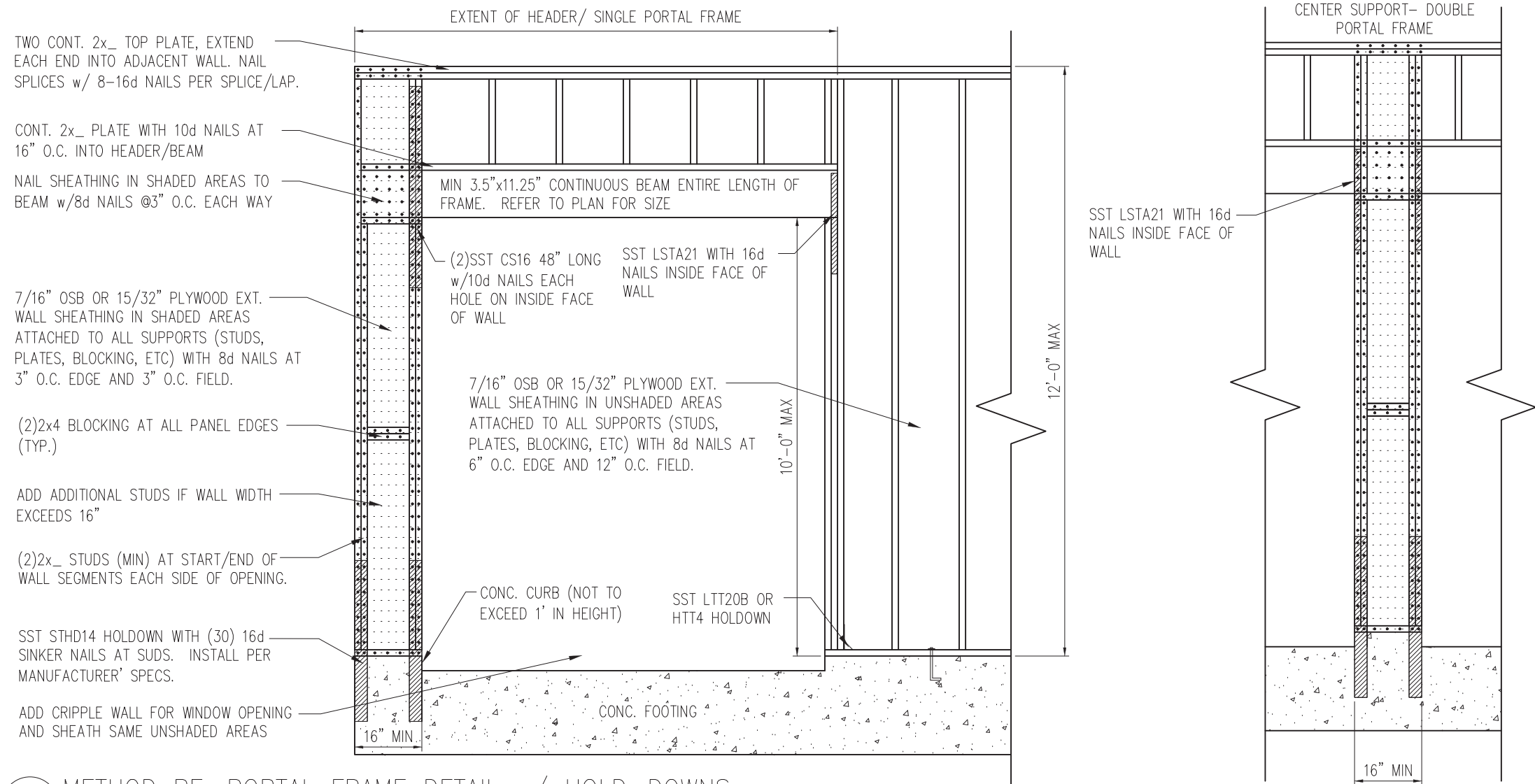

1 METHOD PF: PORTAL FRAME DETAIL w/ HOLD-DOWNS
 D7f 3/4" = 1'-0"

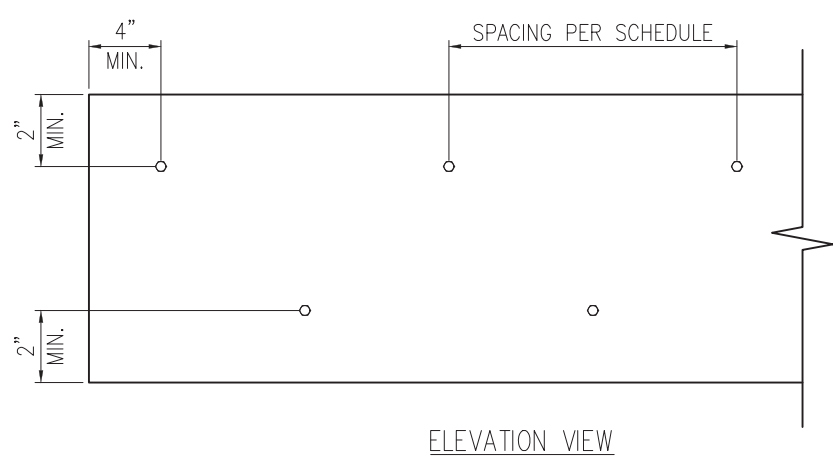

2 MULTI-PLY BEAM CONNECTION DETAIL
 D7f N.T.S.

MINIMUM FASTENING REQUIREMENTS FOR TOP- AND SIDE-LOADED MEMBERS

FASTENER TYPE	LVL DEPTH	3 1/2" WIDE		5 1/4" WIDE		7" WIDE	
		2-Ply 1 3/4"	3-Ply 1 3/4"	1 3/4" + 3 1/2"	4-Ply 1 3/4"	2-Ply 1 3/4" + 3 1/2"	2-Ply 3 1/2"
10d (0.128" x 3") Nails	7 1/4" ≤ d < 14"	3 rows @ 12" o.c.	3 rows @ 12" o.c. (ES)	3 rows @ 12" o.c.	-	3 rows @ 12" o.c. (ES)	-
	d ≥ 14"	4 rows @ 12" o.c.	4 rows @ 12" o.c. (ES)	4 rows @ 12" o.c.	-	4 rows @ 12" o.c. (ES)	-
16d (0.162" x 3 1/2") Nails	7 1/4" ≤ d < 14"	2 rows @ 12" o.c.	2 rows @ 12" o.c. (ES)	2 rows @ 12" o.c.	-	2 rows @ 12" o.c. (ES)	-
	d ≥ 14"	3 rows @ 12" o.c.	3 rows @ 12" o.c. (ES)	3 rows @ 12" o.c.	-	3 rows @ 12" o.c. (ES)	-
1/2" Through Bolts	d ≥ 7 1/4"	2 rows @ 24" o.c.	2 rows @ 24" o.c.		2 rows @ 24" o.c.		-
SDS 1/4" x 3 1/2", WS35, 3 3/8" TrussLok		2 rows @ 24" o.c.	2 rows @ 24" o.c. (ES)	2 rows @ 24" o.c.	-	2 rows @ 24" o.c. (ES)	-
SDS 1/4" x 6", WS6		-	-	-	2 rows @ 24" o.c. (ES)		-
5" TrussLok		-	2 rows @ 24" o.c.		-		-
6 3/4" TrussLok		-	-	-	2 rows @ 24" o.c.		-

NOTES:

- All fasteners must meet the minimum requirements in the table above. Side-loaded multiple-ply members must meet the minimum fastening and side-loading capacity requirements given on page 48.
- Minimum fastening requirements for depths less than 7 1/4" require special consideration. Please contact your technical representative.
- Three general rules for staggering or offsetting for a certain fastener schedule:
 - If staggering or offsetting is not referenced, then none is required;
 - If staggering is referenced, then fasteners installed in adjacent rows on the front side are to be staggered up to one-half the o.c. spacing, but maintaining the fastener clearances above; and
 - If "ES" is referenced, then the fastener schedule must be repeated on each side, with the fasteners on the back side offset up to one-half the o.c. spacing of the front side (whether or not it is staggered).

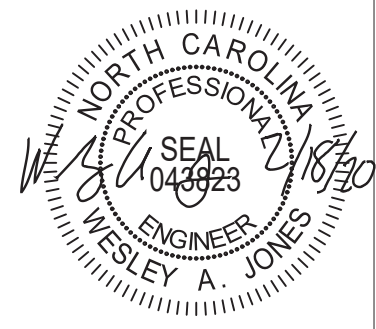

STRUCTURAL MEMBERS ONLY

SUMMIT
 ENGINEERING LABORATORY TESTING
 3070 HAMMOND BUSINESS PLACE,
 SUITE 171, RALEIGH, NC 27603
 OFFICE: 919.380.9991
 FAX: 919.380.9993
 WWW.SUMMIT-COMPANIES.COM

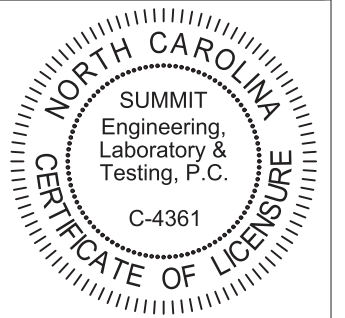

PROJECT
 Standard Details
 Framing Details - Bracing
 CLIENT
 Smith Douglas Homes
 110 Village Trail, Suite 215
 Woodstock, GA 30188

CURRENT DRAWING
 DATE: 2/18/20
 SCALE: NTS
 PROJECT #: 3832
 DRAWN BY: LBV
 CHECKED BY: WAJ
 ORIGINAL DRAWING
 NO. DATE PROJECT #
 0 1/7/16 3832

REFER TO COVER SHEET FOR A COMPLETE LIST OF REVISIONS

SHEET
D7f

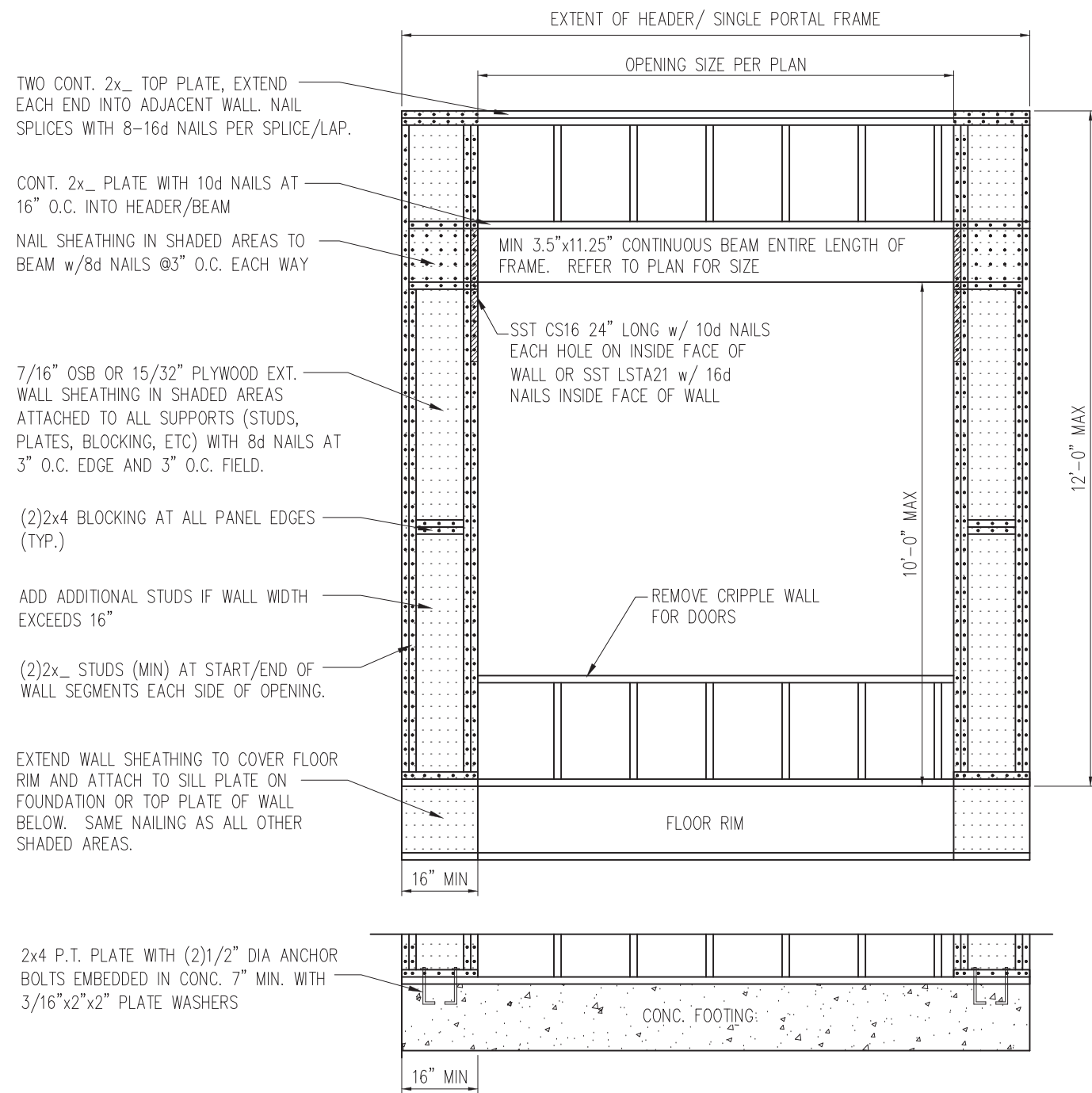

1 METHOD PF: PORTAL FRAME DETAIL
 D8f 3/4" = 1'-0" OPENINGS UNDER 8'-0"

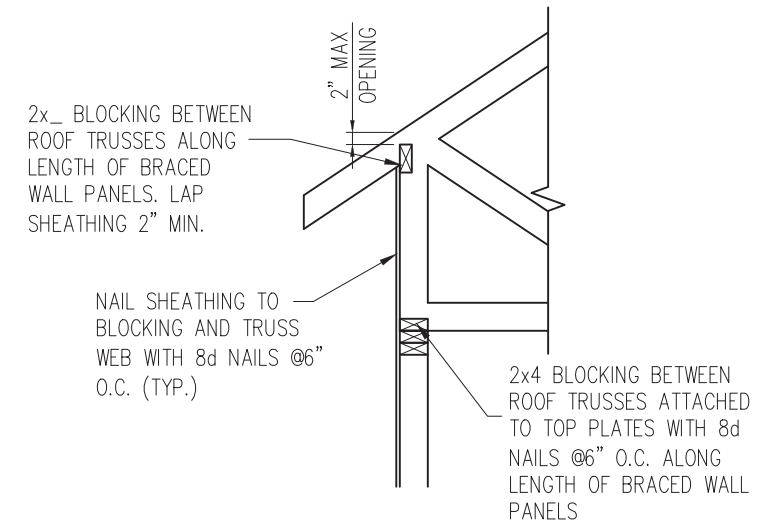

HEEL HEIGHT GREATER THAN 15.25"

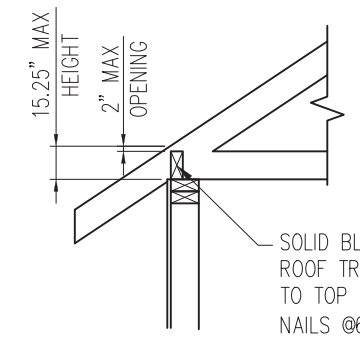

HEEL HEIGHT LESS THAN 15.25" *

*BLOCKING IS NOT REQUIRED WITH HEEL HEIGHTS LESS THAN 9.25"

2 TYP. WALL PANEL TO ROOF TRUSS CONNECTION
 D8f 1" = 1'-0"



STRUCTURAL MEMBERS ONLY

SUMMIT
 ENGINEERING LABORATORY TESTING
 3070 HAMMOND BUSINESS PLACE,
 SUITE 171, RALEIGH, NC 27603
 OFFICE: 919.380.9991
 FAX: 919.380.9993
 WWW.SUMMIT-COMPANIES.COM

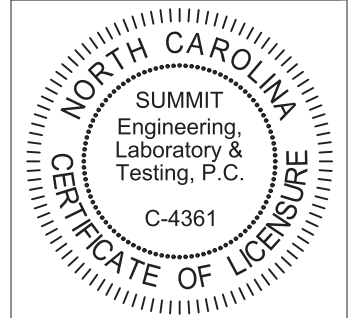

PROJECT
Standard Details - Bracing
Framing Details - Bracing
 CLIENT
Smith Douglas Homes
 110 Village Trail, Suite 215
 Woodstock, GA 30188

CURRENT DRAWING
 DATE: 2/18/20
 SCALE: NTS
 PROJECT #: 3832
 DRAWN BY: LBV
 CHECKED BY: WAJ

ORIGINAL DRAWING
 NO. DATE PROJECT #
 0 1/7/16 3832

REFER TO COVER SHEET FOR A COMPLETE LIST OF REVISIONS

SHEET
D8f

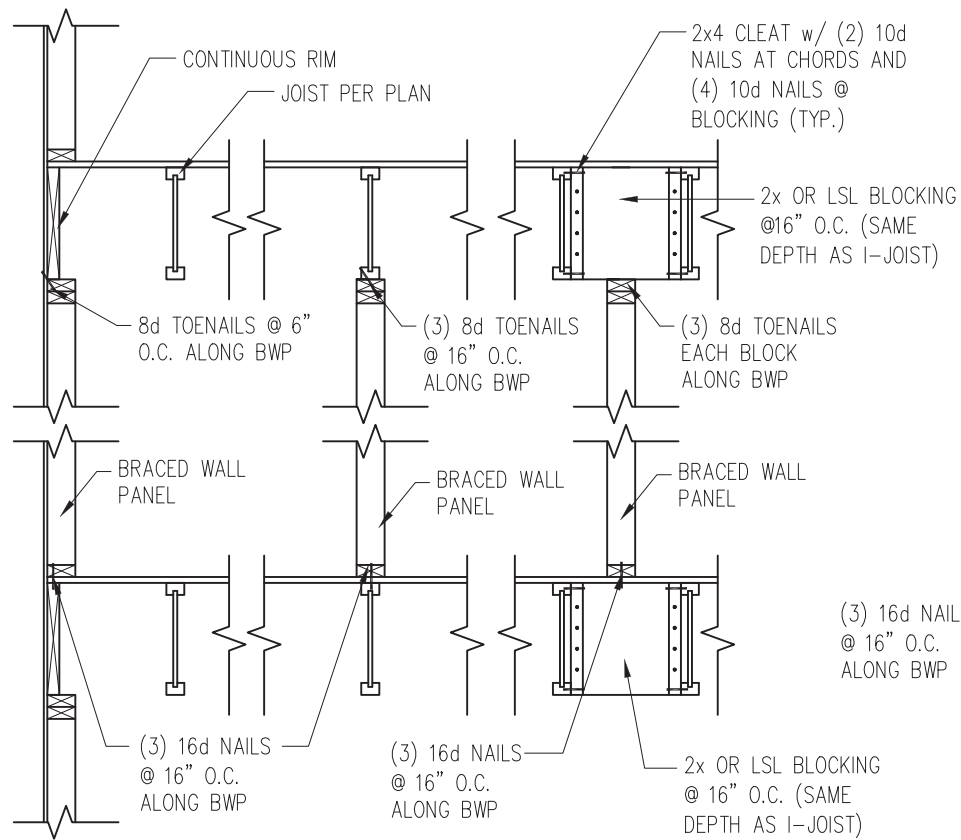

JOISTS PARALLEL TO BRACED WALLS

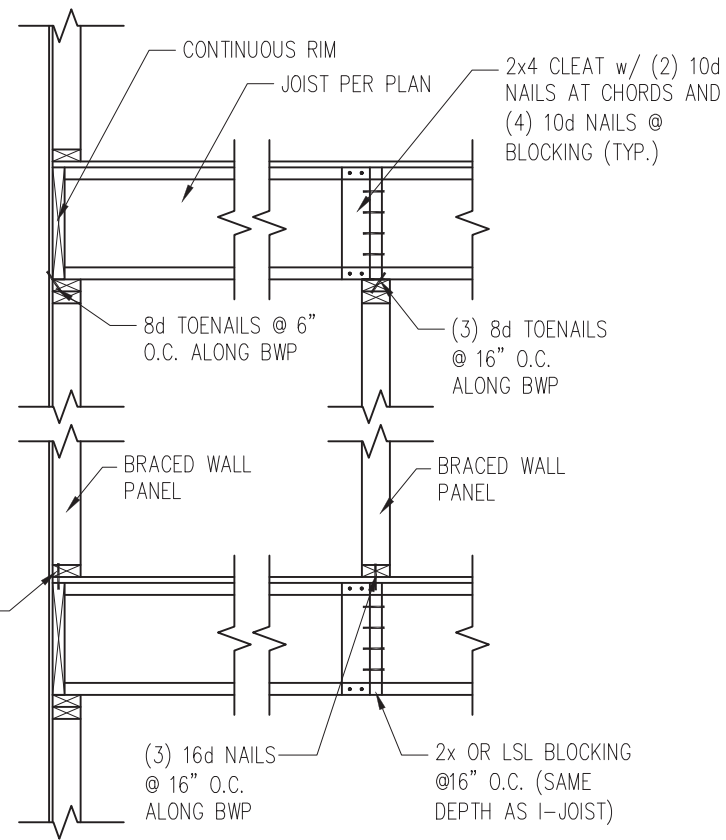

JOISTS PERPENDICULAR TO BRACED WALLS

1 TYP. WALL PANEL TO FLOOR/CEILING CONNECTION
D9f 1" = 1'-0"

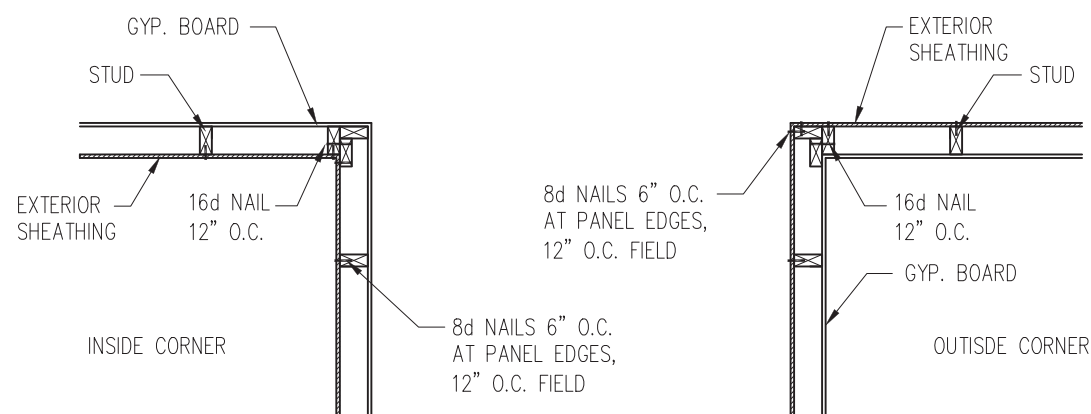

2 TYP. EXTERIOR CORNER FRAMING
D9f 1" = 1'-0"

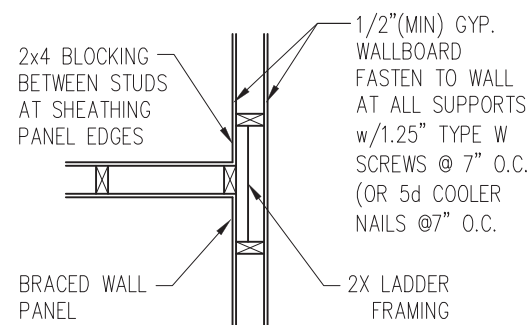

3 INTERIOR 3-STUD WALL INTERSECTION
D9f 1" = 1'-0"

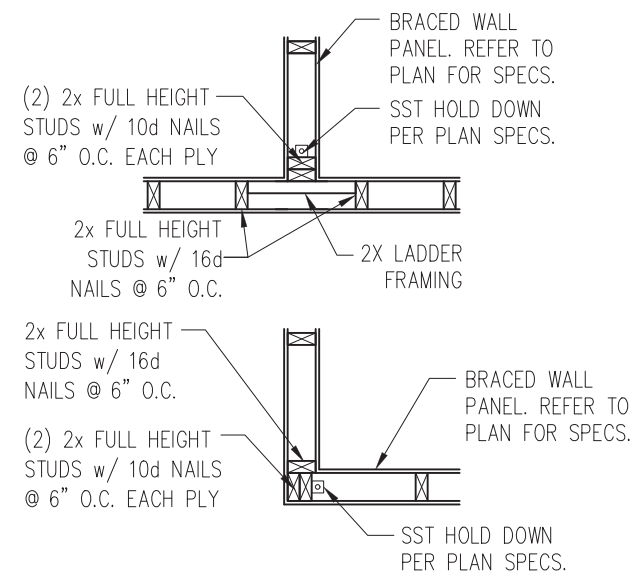

4 TYP. HOLD DOWN DETAIL
D9f 1" = 1'-0"

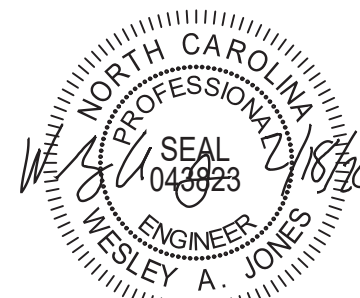

STRUCTURAL MEMBERS ONLY

SUMMIT
ENGINEERING LABORATORY TESTING
3070 HAMMOND BUSINESS PLACE,
SUITE 171, RALEIGH, NC 27603
OFFICE: 919.380.9991
FAX: 919.380.9993
WWW.SUMMIT-COMPANIES.COM

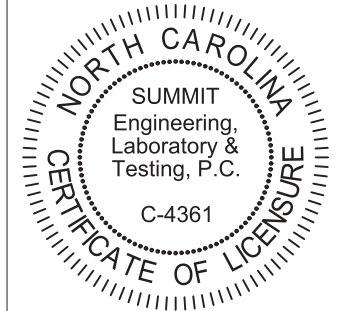

PROJECT
Standard Details
Framing Details - Bracing
CLIENT
Smith Douglas Homes
110 Village Trail, Suite 215
Woodstock, GA 30188

CURRENT DRAWING
DATE: 2/18/20
SCALE: NTS
PROJECT #: 3832
DRAWN BY: LBV
CHECKED BY: WAJ

ORIGINAL DRAWING
NO. DATE PROJECT #
0 1/7/16 3832

REFER TO COVER SHEET FOR A COMPLETE LIST OF REVISIONS

SHEET

D9f

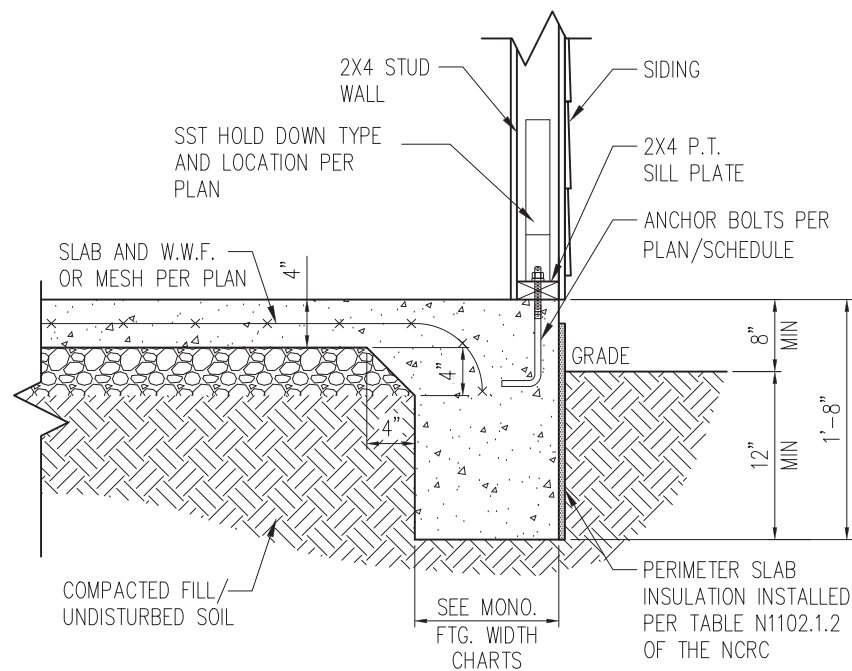

1 SLAB DETAIL w/ HOLD-DOWN
 D10f 3/4" = 1'-0"

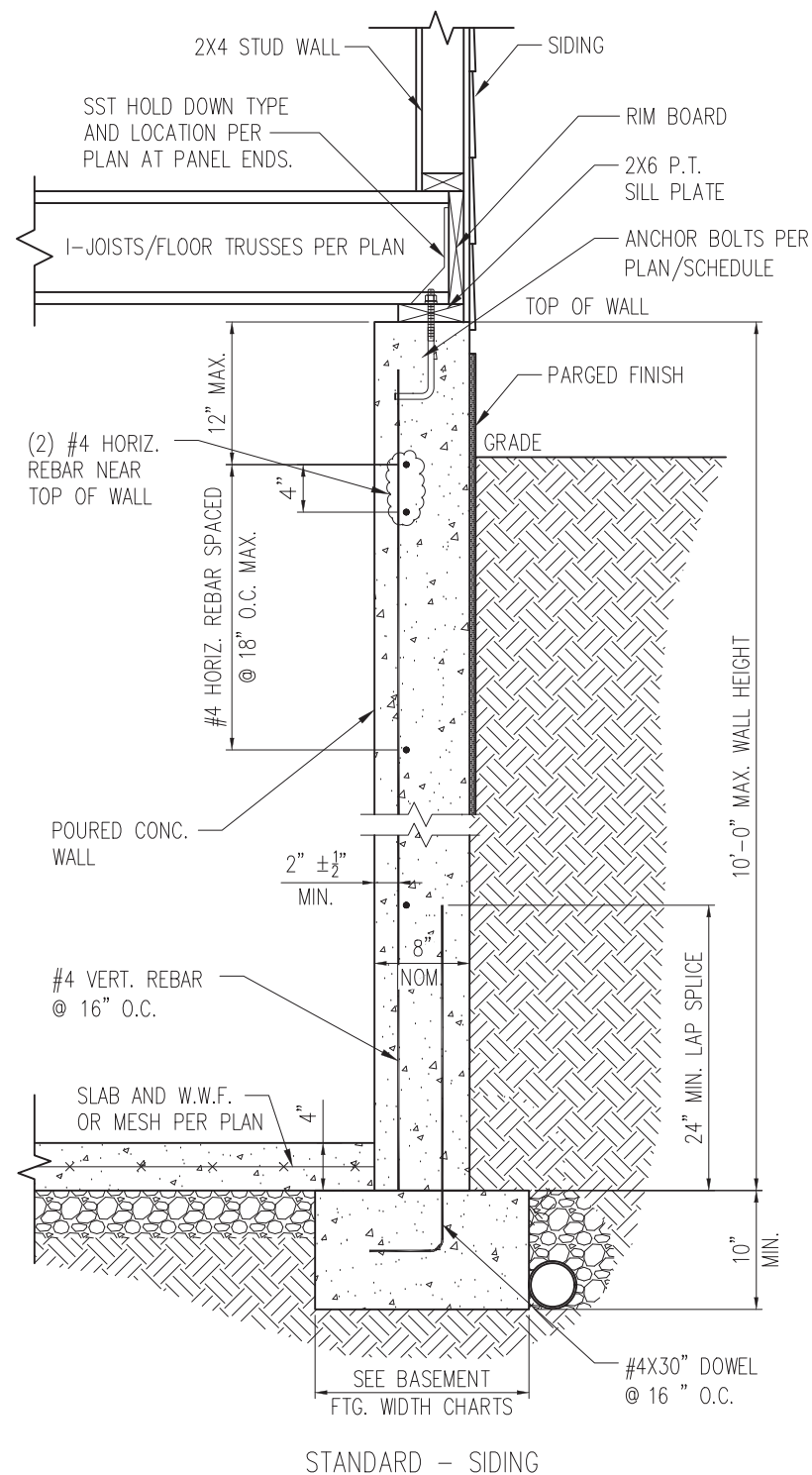

2 BASEMENT FOUNDATION WALL DETAIL W/ HOLD-DOWN
 D10f 3/4" = 1'-0"



STRUCTURAL MEMBERS ONLY

SUMMIT
 ENGINEERING LABORATORY TESTING
 3070 HAMMOND BUSINESS PLACE,
 SUITE 171, RALEIGH, NC 27603
 OFFICE: 919.380.9991
 FAX: 919.380.9993
 WWW.SUMMIT-COMPANIES.COM

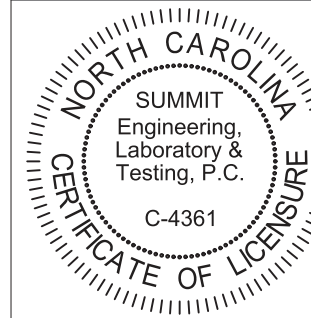

PROJECT
Standard Details
Framing Details - Bracing
 CLIENT
Smith Douglas Homes
 110 Village Trail, Suite 215
 Woodstock, GA 30188

CURRENT DRAWING
 DATE: 2/18/20
 SCALE: NTS
 PROJECT #: 3832
 DRAWN BY: LBV
 CHECKED BY: WAJ

ORIGINAL DRAWING
 NO. DATE PROJECT #
 0 1/7/16 3832

REFER TO COVER SHEET FOR A COMPLETE LIST OF REVISIONS

SHEET
D10f

TRUSS TO WALL CONNECTIONS, IF SHOWN, ARE FOR UPLIFT ONLY AND DO NOT CONSIDER LATERAL LOADS. ALL CONNECTORS ON THIS PROJECT ARE TO BE INSTALLED PER THE CONNECTOR MANUFACTURER'S SPECIFICATIONS. ALL CONNECTORS SHOWN THAT ARE NOT "TRUSS TO TRUSS" ARE SUGGESTIONS ONLY AND ARE TO BE VERIFIED BY THE BUILDING DESIGNER OR ENGINEER OF RECORD FOR SUITABILITY TO THIS PARTICULAR PROJECT. UFP MID-ATLANTIC, LLC, ACCEPTS NO RESPONSIBILITY FOR THE SPECIFIC APPLICATION OR SUITABILITY OF ANY CONNECTOR THAT IS NOT "TRUSS TO TRUSS" AS THEY APPLY TO THIS SPECIFIC STRUCTURE.

71023502 26 CANE MILL

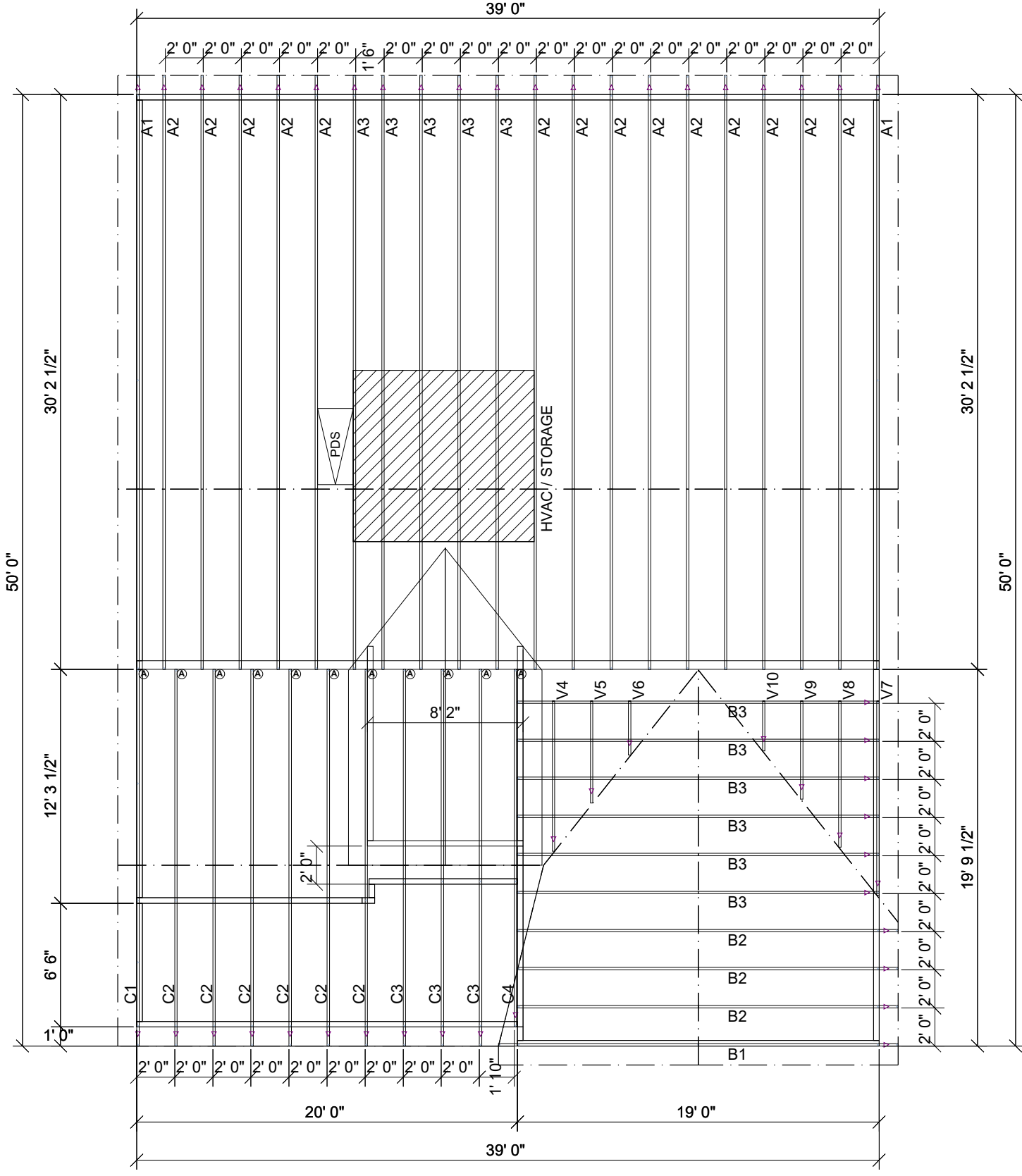
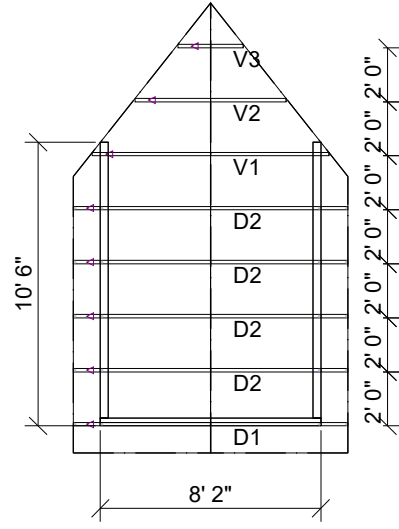

Roof Hanger List

MARK	TYPE	DESCRIPTION	QTY
(A)	HUS26	FACE MOUNT HANGER	11

REGES BEH NO TRAY

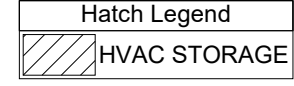

ROOF AREA: 2680.63 RIDGE LINE: 78.42 VALLEY LINES: 64.67 HIP LINES: 0 △ Indicates Left End of Truss

CUSTOMER: **SMITH DOUGLAS**
 Job Name: **REGES BEH**
 Drawn By: **NTS** Quality Products for Quality Builders
 Date: 02-20-20
 Scale: **NTS**
 Revision Date: _____
 Revision Date 2: _____

NOTES: THIS DRAWING IS THE PROPERTY OF UFP MID-ATLANTIC, LLC. IT IS TO BE USED FOR THE PROJECT AND IS NOT TO BE REPRODUCED OR TRANSMITTED IN ANY FORM OR BY ANY MEANS, ELECTRONIC OR MECHANICAL, INCLUDING PHOTOCOPYING, RECORDING, OR BY ANY INFORMATION STORAGE AND RETRIEVAL SYSTEM. THIS DRAWING MUST BE USED IN CONJUNCTION WITH ALL OTHER TECHNICAL DRAWINGS SUPPLIED BY UFP MID-ATLANTIC, LLC AND BRACING WOOD TRUSSES, COMMENTARY AND RECOMMENDATIONS AS PUBLISHED BY THE TRUSS MANUFACTURER. TRUSSES (TR) IS LOCATED AT 683 D CONFRID DR, SUITE 200 MADISON, VA 15279 (603) 833-5600

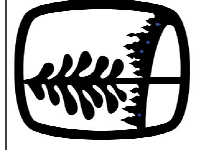

UFP MID-ATLANTIC, LLC
 A UNIVERSAL FOREST PRODUCTS COMPANY
 BURLINGTON, NC PHONE (800) 476-9356
 CHESAPEAKE, VA PHONE (800) 476-3190
 CONWAY, SC PHONE (800) 397-9572
 JEFFERSON GA PHONE (800) 648-4038
 PEARISBURG, VA PHONE (800) 397-9571

This layout is not an engineered drawing. This drawing was created to establish truss placement only. It is the responsibility of the builder to provide adequate support for all the elements shown in this drawing.

1. TEMPORARY BRACING TO BE INSTALLED w/T.P.I. STANDARD BCSI-B1.
2. SEE ENGINEERED DRAWING FOR PERMANENT BRACING MINIMUM REQUIREMENTS.
3. FRAMER TO VERIFY ALL DIMENSIONS, DROP, & RISE LOCATIONS PRIOR TO TRUSS PLACEMENT.
4. BLDG/FRAMER RESPONSIBLE FOR ADJUSTMENT OF TRUSS SPACING TO MISS PLUMBING DROPS, UNLESS NOTED OTHERWISE.

Products					
Fab Type	Net Qty	Plies	Product	Length	PlotID
MFD	3	1	14" TJI@ 110	30' 0"	J1
MFD	5	1	14" TJI@ 110	17' 0"	J2
MFD	9	1	14" TJI@ 110	16' 0"	J3
MFD	4	1	14" TJI@ 110	11' 0"	J4
MFD	2	1	14" TJI@ 110	7' 0"	J5
MFD	1	1	14" TJI@ 110	5' 0"	J6
MFD	3	1	14" TJI@ 110	4' 0"	J7
MFD	11	1	14" TJI@ 210	19' 0"	J8
MFD	4	2	1 3/4" x 9 1/4" 2.0E Microllam@ LVL	9' 0"	2B-1
MFD	2	2	1 3/4" x 16" 2.0E Microllam@ LVL	20' 0"	GDH
MFD	9	1	1 1/8" x 14" TJI@ Rim Board	16' 0"	RIM-1
MFD	17	1	14" TJI@ 110	2' 0"	Bk1

Connector Summary			
Product	Manuf	Qty	PlotID
IHFL1714	USP	7	H1
IHFL2014	USP	9	H2
TFL1714	USP	4	H3

PLAN LEGEND

*INDICATES BEAM ABOVE TOP PLATE (FLUSH WITH FLOOR SYSTEM)

1B-, 2B-

INDICATES BEAM BELOW TOP PLATE (DROPPED BELOW FLOOR SYSTEM)

H-, 1H-, GDH-

*BEAMS MAY PROTRUDE ABOVE OR BELOW DECKING OR TOP PLATE RESPECTIVELY, REFER TO DETAIL IF BEAM IS A DIFFERENT DEPTH THAN FLOOR SYSTEM

SINGLE PLY BEAM (ADD LINE FOR EACH ADDITIONAL PLY)

SHIFT JOIST TO MISS PLUMBING, ALIGN W/WALL OR SUPPORT FURNITURE

A JOIST ADDED TO THE LAYOUT IN ADDITION TO THE ON CENTER JOISTS

TWO JOISTS SIDE BY SIDE (ONLY ASSEMBLED IF NOTED)

SHIFT

EXTRA

DOUBLE

GENERAL NOTES:

- 1.) TOP CHORD OF JOISTS ARE PAINTED RED AT NUMBERED END. PLACE PAINTED END AS NOTED ON PLAN.
- 2.) FOLLOW SPECIAL SPACING AND LOCATION DIMENSIONS FOR EXTRAS OR SHIFTED JOISTS AS SHOWN ON PLAN.
- 3.) ALL INTERIOR WALL PLATES MUST BE LEVEL WITH OUTSIDE WALL TOP PLATES.
- 4.) DO NOT STACK CONSTRUCTION LOADS ON UN-BRACED JOISTS.
- 5.) PROVIDE SOLID SUPPORT BELOW ALL BEAM AND HEADER BEARING POINTS IN WALL AND JOIST SPACES CONTINUOUS DOWN TO THE FOUNDATION.
- 6.) LOCATE CRIPPLE STUDS IN JOIST SPACE DIRECTLY BELOW HEADER JACKS AT ALL FIRST FLOOR EXTERIOR DOOR LOCATIONS.
- 7.) INSTALL NAILS IN ALL HOLES PROVIDED IN JOIST HANGERS EXCEPT AT BOTTOM CHORD SEAT. PLACE A DAB OF GLUE IN THE HANGER SEAT BEFORE SETTING JOISTS.
- 8.) IMPORTANT NOTE! NO STRUCTURAL ANALYSIS OF CONVENTIONAL HEADERS HAS BEEN CONDUCTED IF NOT NOTED. THEY ARE CONSIDERED TO BE ADEQUATE TO SUPPORT THE APPLIED LOADS.

FRAMER NOTE

DENOTES DUCT HOLE RUNS

ALL DIMENSIONS TO CENTERLINE UNLESS OTHERWISE NOTED

Avoid Plumbing Drops

FRAMER NOTE

1. GLUE AND NAIL PLYWOOD SUBFLOOR TO BEAMS AND GIRDERS AT 6" O/C WHERE NO WALL IS ABOVE.
2. FILL HANGER SEAT WITH GLUE BEFORE SETTING JOIST IN HANGER. FILL ROUND HOLES WITH NAILS.

CRITICAL !!

INSTALL 2X4 SQUASH BLOCKS IN FLOOR TRUSS SPACE BELOW ALL EXTERIOR DOOR HEADER JACKS. CUT 1/16" TALLER THAN TRUSS.

FIELD TRIM NON RED END TO KEEP HOLES ALIGNED
CONTAR EL LADO DE SIN MARCA ROJA PARA HOYOS ALINEADOS

FIELD LOCATE PLUMBING DROPS/CAN LIGHTS, ETC... PRIOR TO JOIST SECUREMENT TO AVOID INTERFERENCE.

LAYOUT FOR 19.2" O/C

9= 172-13/16"	1= 19-3/16"
10= 192"	2= 38-3/8"
11= 211-3/16"	3= 57-5/8"
12= 230-3/8"	4= 76-13/16"
13= 249-13/16"	5= 96"
14= 268-13/16"	6= 115-3/16"
15= 288"	7= 134-3/8"
	8= 153-5/8"

FIELD VERIFY DIMENSIONS TO JOISTS LOCATED UNDER WALLS!!

2ND FLOOR LAYOUT

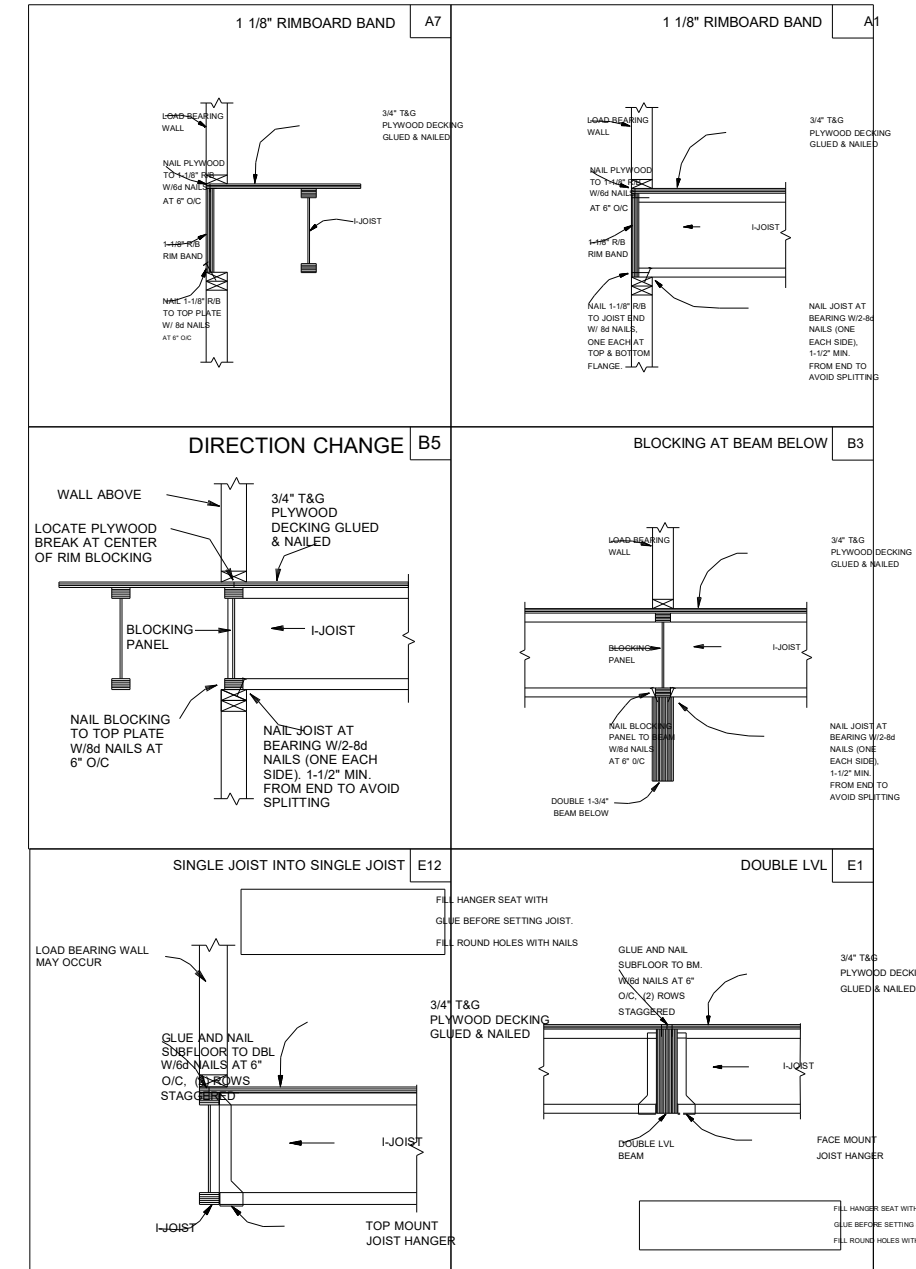
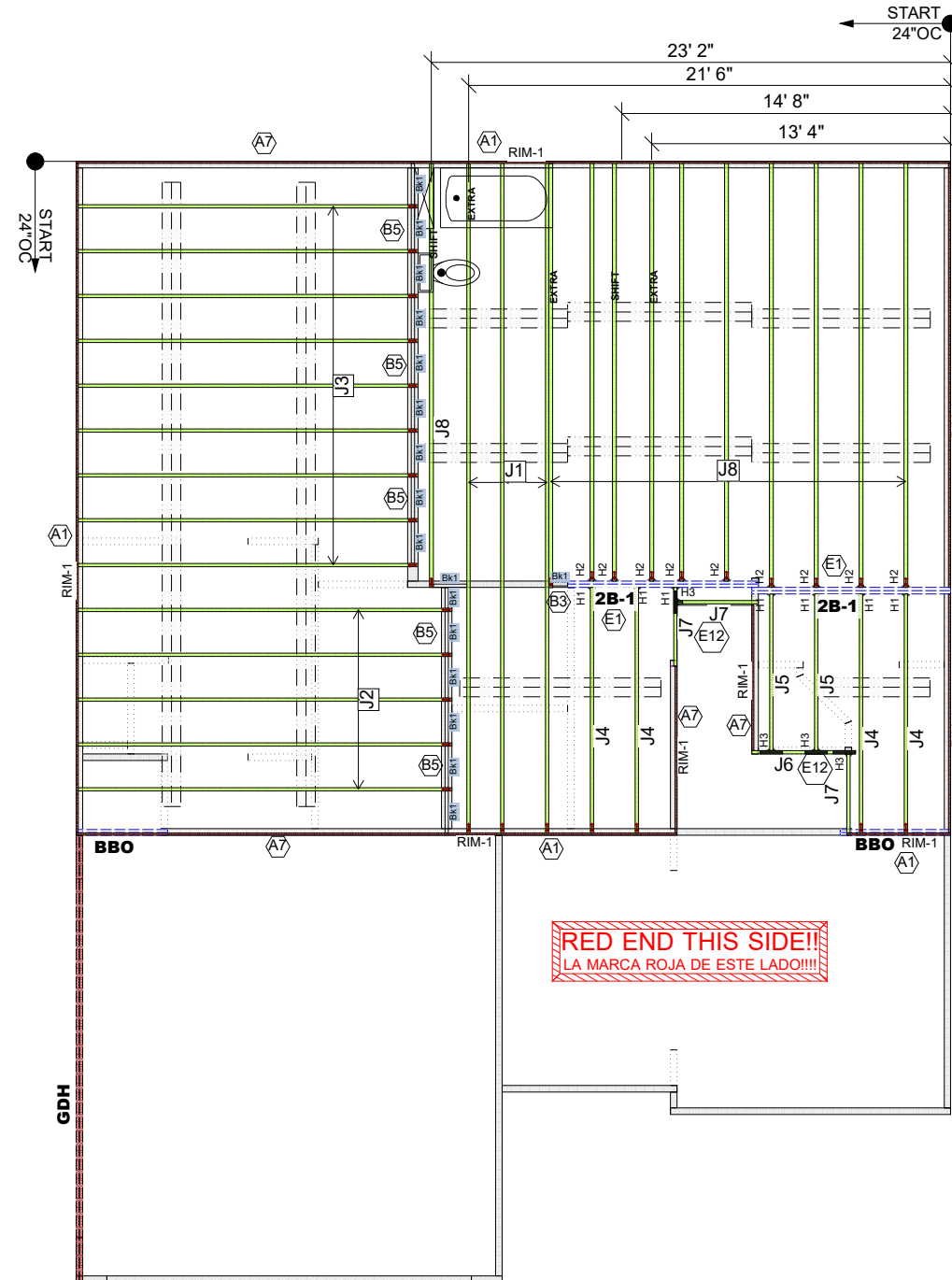

This layout is not an engineered drawing. This drawing was created to establish joist placement only. It is the responsibility of the builder to provide adequate support for all the elements shown in this drawing.

UFP MID-ATLANTIC, LLC NOTES: THIS DRAWING IS THE PROPERTY OF UFP MID-ATLANTIC, LLC AND IS NOT TO BE USED FOR ANY PURPOSE DETERMINANT TO THE INTEREST OF UFP MID-ATLANTIC, LLC. THIS DRAWING MUST BE USED IN CONJUNCTION WITH ALL OTHER TECHNICAL DRAWINGS SUPPLIED BY UFP MID-ATLANTIC, LLC.

A UNIVERSAL FOREST PRODUCTS COMPANY
 BURLINGTON, NC PHONE (800) 476-9356
 CHESAPEAKE, VA PHONE (800) 476-3190
 CONWAY, SC PHONE (800) 397-9572
 JEFFERSONGA PHONE (800) 648-4038
 PEARISBURG, VA PHONE (800) 397-9571

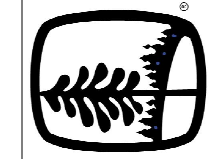

LOADING	DEFLECTION	Special Loading:	
		ROOF LIVE	FLOOR DEAD
20 PSF	L/240	20 PSF	L/240
40 PSF	L/180	40 PSF	L/180
10 PSF	L/480	10 PSF	L/480

Customer: **SMITH DOUGLAS**
 Job Name: **REGES**
 Date: 3/13/2020
 Scale: NTS
 Revision Date: _____
 Revision Date: _____

Checked By: EOR
 Drawing Number: **18122209F2**
MSTR

This layout is not an engineered drawing. This drawing was created to establish joist placement only. It is the responsibility of the builder to provide adequate support for all the elements shown in this drawing.

UFP MID-ATLANTIC, LLC NOTES: THIS DRAWING IS THE PROPERTY OF UFP MID-ATLANTIC, LLC AND IS NOT TO BE USED FOR ANY PURPOSE DETERMINAL TO THE INTEREST OF UFP MID-ATLANTIC, LLC. THIS DRAWING MUST BE USED IN CONJUNCTION WITH ALL OTHER TECHNICAL DRAWINGS SUPPLIED BY UFP MID-ATLANTIC, LLC.

A UNIVERSAL FOREST PRODUCTS COMPANY
 BURLINGTON, NC PHONE (800) 476-9356
 CHESAPEAKE, VA PHONE (800) 476-3190
 CONWAY, SC PHONE (800) 397-9572
 JEFFERSONGA PHONE (800) 648-4038
 PEARISBURG, VA PHONE (800) 397-9571

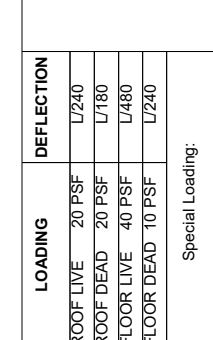

Customer	Job Name	Date	Scale	Revision	Date	DEFLECTION	
						LOADING	Special Loading
SMITH DOUGLAS	REGES	3/13/2020	Quality Products for Quality Builders			ROOF LIVE	20 PSF
						ROOF DEAD	20 PSF
						FLOOR LIVE	40 PSF
						FLOOR DEAD	10 PSF
							L/240
							L/180
							L/480
							L/240

Products					
PlotID	Length	Product	Plies	Net Qty	Fab Type
J1	30' 0"	14" TJI@ 110	1	3	MFD
J2	17' 0"	14" TJI@ 110	1	5	MFD
J3	16' 0"	14" TJI@ 110	1	9	MFD
J4	11' 0"	14" TJI@ 110	1	4	MFD
J5	7' 0"	14" TJI@ 110	1	2	MFD
J6	5' 0"	14" TJI@ 110	1	1	MFD
J7	4' 0"	14" TJI@ 110	1	3	MFD
J8	19' 0"	14" TJI@ 210	1	11	MFD
2B-1	9' 0"	1 3/4" x 9 1/4" 2.0E Microllam@ LVL	2	4	MFD
GDH	20' 0"	1 3/4" x 16" 2.0E Microllam@ LVL	2	2	MFD
RIM-1	16' 0"	1 1/8" x 14" TJI@ Rim Board	1	9	MFD
Bk1	2' 0"	14" TJI@ 110	1	17	MFD

Connector Summary			
PlotID	Qty	Manuf	Product
H1	7	USP	IHFL1714
H2	9	USP	IHFL2014
H3	4	USP	TFL1714

GENERAL NOTES:

- 1.) TOP CHORD OF JOISTS ARE PAINTED RED AT NUMBERED END. PLACE PAINTED END AS NOTED ON PLAN.
- 2.) FOLLOW SPECIAL SPACING AND LOCATION DIMENSIONS FOR EXTRAS OR SHIFTED JOISTS AS SHOWN ON PLAN.
- 3.) ALL INTERIOR WALL PLATES MUST BE LEVEL WITH OUTSIDE WALL TOP PLATES.
- 4.) DO NOT STACK CONSTRUCTION LOADS ON UN-BRACED JOISTS.
- 5.) PROVIDE SOLID SUPPORT BELOW ALL BEAM AND HEADER BEARING POINTS IN WALL AND JOIST SPACES CONTINUOUS DOWN TO THE FOUNDATION.
- 6.) LOCATE CRIPPLE STUDS IN JOIST SPACE DIRECTLY BELOW HEADER JACKS AT ALL FIRST FLOOR EXTERIOR DOOR LOCATIONS.
- 7.) INSTALL NAILS IN ALL HOLES PROVIDED IN JOIST HANGERS EXCEPT AT BOTTOM CHORD SEAT. PLACE A DAB OF GLUE IN THE HANGER SEAT BEFORE SETTING JOISTS.
- 8.) IMPORTANT NOTE! NO STRUCTURAL ANALYSIS OF CONVENTIONAL HEADERS HAS BEEN CONDUCTED IF NOT NOTED. THEY ARE CONSIDERED TO BE ADEQUATE TO SUPPORT THE APPLIED LOADS.

FRAMER NOTE

--- DENOTES DUCT HOLE RUNS

ALL DIMENSIONS TO CENTERLINE UNLESS OTHERWISE NOTED

• Avoid Plumbing Drops

FRAMER NOTE

1. GLUE AND NAIL PLYWOOD SUBFLOOR TO BEAMS AND GIRDERS AT 6" O/C WHERE NO WALL IS ABOVE.
2. FILL HANGER SEAT WITH GLUE BEFORE SETTING JOIST IN HANGER. FILL ROUND HOLES WITH NAILS.

CRITICAL !!

INSTALL 2X4 SQUASH BLOCKS IN FLOOR TRUSS SPACE BELOW ALL EXTERIOR DOOR HEADER JACKS. CUT 1/16" TALLER THAN TRUSS.

PLAN LEGEND

1B-, 2B- *INDICATES BEAM ABOVE TOP PLATE (FLUSH WITH FLOOR SYSTEM)

H-, 1H-, GDH- INDICATES BEAM BELOW TOP PLATE (DROPPED BELOW FLOOR SYSTEM)

*BEAMS MAY PROTRUDE ABOVE OR BELOW DECKING OR TOP PLATE RESPECTIVELY. REFER TO DETAIL IF BEAM IS A DIFFERENT DEPTH THAN FLOOR SYSTEM

--- SINGLE PLY BEAM (ADD LINE FOR EACH ADDITIONAL PLY)

SHIFT SHIFT JOIST TO MISS PLUMBING, ALIGN W/WALL OR SUPPORT FURNITURE

EXTRA A JOIST ADDED TO THE LAYOUT IN ADDITION TO THE ON CENTER JOISTS

DOUBLE TWO JOISTS SIDE BY SIDE (ONLY ASSEMBLED IF NOTED)

FIELD TRIM NON RED END TO KEEP HOLES ALIGNED
 CONTAR EL LADO DE SIN MARCA ROJA PARA HOYOS ALINEADOS

FIELD LOCATE PLUMBING DROPS/CAN LIGHTS, ETC... PRIOR TO JOIST SECUREMENT TO AVOID INTERFERENCE.

LAYOUT FOR 19.2" O/C

1= 19-3/16"	9= 172-13/16"
2= 38-3/8"	10= 192"
3= 57-5/8"	11= 211-3/16"
4= 76-13/16"	12= 230-3/8"
5= 96"	13= 249-13/16"
6= 115-3/16"	14= 268-13/16"
7= 134-3/8"	15= 288"
8= 153-5/8"	

FIELD VERIFY DIMENSIONS TO JOISTS LOCATED UNDER WALLS!!

2ND FLOOR LAYOUT

