

N/F  
WOOD, W DAVID JR  
& WOOD, SYLVIA L  
PIN:1519-20-3696;000

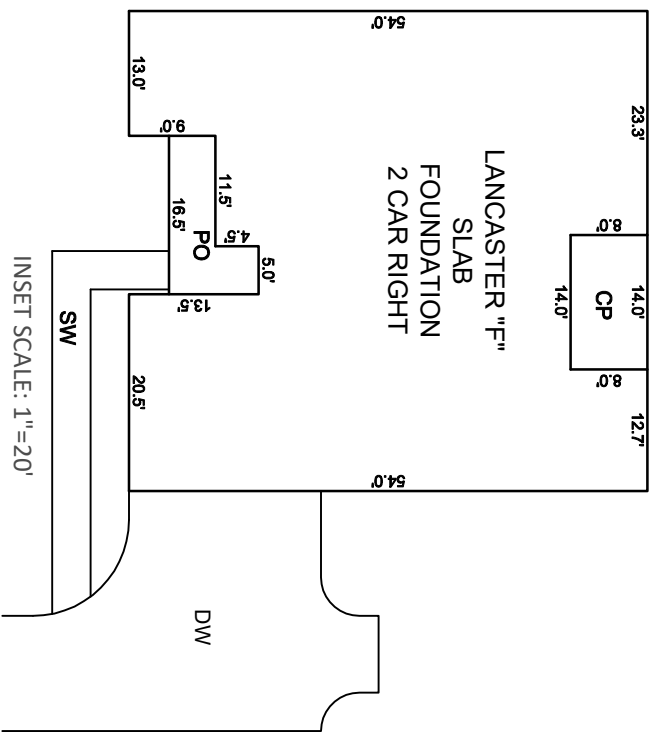

- NOTES:**
- THIS SURVEY WAS PREPARED BY BATEMAN CIVIL SURVEY CO., UNDER THE SUPERVISION OF STEVEN P. CARSON, PLS.
  - THIS PLAN HAS BEEN PREPARED FOR LAYOUT AND PERMITTING PURPOSES ONLY.
  - PROPERTY LINES SHOWN WERE TAKEN FROM EXISTING FIELD EVIDENCE, EXISTING DEEDS AND PLATS OF PUBLIC RECORD, AND INFORMATION SUPPLIED TO THE SURVEYOR BY THE CLIENT.
  - ALL DISTANCES ARE HORIZONTAL GROUND DISTANCES AND ALL BEARINGS ARE NORTH CAROLINA STATE PLANE COORDINATE SYSTEM UNLESS OTHERWISE SHOWN.
  - THIS MAP IS NOT FOR RECORDATION AND SHOULD BE REVIEWED BY A LOCAL GOVERNMENT AGENCY FOR COMPLIANCE WITH ANY APPLICABLE LAND DEVELOPMENT REGULATIONS.
  - THE BASIS OF NORTH AND ALL EASEMENTS, RIGHTS-OF-WAYS, BUFFERS, SETBACKS AND ADJOINERS, ETC. REFERENCED IN TITLE BLOCK.
  - NO INVESTIGATION INTO THE EXISTENCE OF JURISDICTIONAL WETLANDS OR RIPARIAN BUFFERS PERFORMED BY THIS FIRM.
  - SURVEYOR HAS MADE NO INVESTIGATION OR INDEPENDENT SEARCH FOR EASEMENTS OF RECORD, ENCUMBRANCES, RESTRICTIVE COVENANTS, OWNERSHIP TITLE EVIDENCE OR ANY OTHER FACTS THAT AN ACCURATE AND CURRENT TITLE SEARCH MAY DISCLOSE.
  - THE PROPERTY LIES IN ZONE "X" PER NATIONAL INSURANCE PROGRAM FLOOD INSURANCE RATE MAP #37201519001, DATED 10/03/2006.
  - ALL CONSTRUCTION SHALL BE DONE IN ACCORDANCE WITH ALL TOWN OF COATS AND NCDOT STANDARDS AND SPECIFICATIONS.
  - ZONING IS RA-30.
  - PROPERTY OWNER: SMITH DOUGLAS HOMES  
2520 RELIANCE AVENUE  
APEX, NC 27539

CURVE TABLE				
CURVE	RADIUS	LENGTH	CHORD DIRECTION	CHORD
C15	1228.03'	125.58'	N63°07'10"W	125.54'

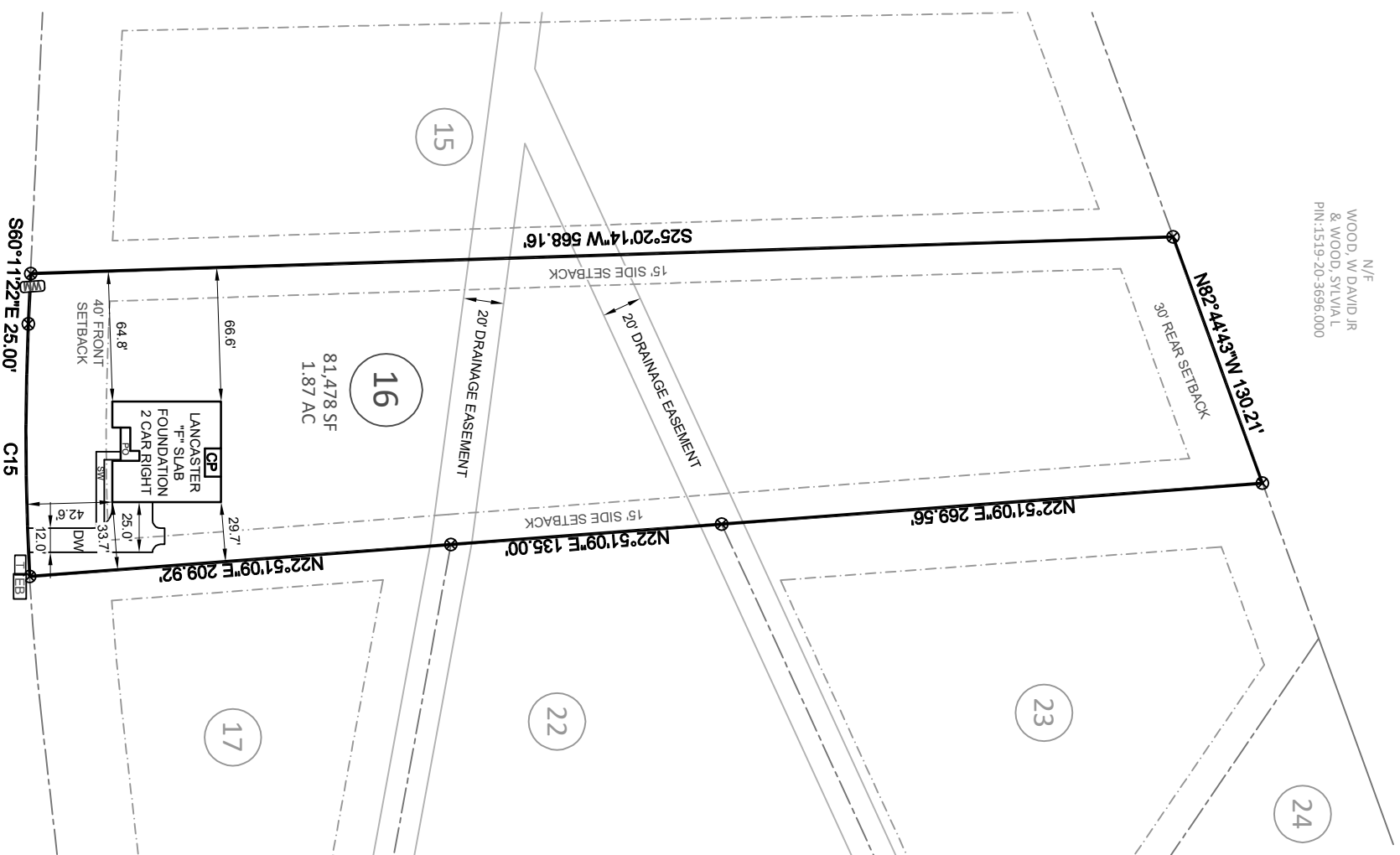

**LOT INFORMATION:**  
PIN: 1519-21-8294.000  
TOTAL LOT AREA = 1.87 AC = 81,478 SF  
PROPOSED IMPERVIOUS = 3,892 SF  
BLDG = 2,417 SF  
CP = 112 SF  
PO = 102 SF  
SW = 181 SF  
DW = 1,080 SF  
PERCENT IMPERVIOUS = 4.78 %

**REVISION: CHANGED HOUSE MODEL PER REQUEST. CPV 7/2/21**

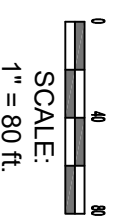

**Bateman Civil Survey Company**  
Engineers • Surveyors • Planners  
2524 Reliance Avenue, Apex, NC 27539 Ph: 919.577.1080 Fax: 919.577.1081  
www.batemancivilsurvey.com info@batemancivilsurvey.com  
NCBELS Firm No. C-2378

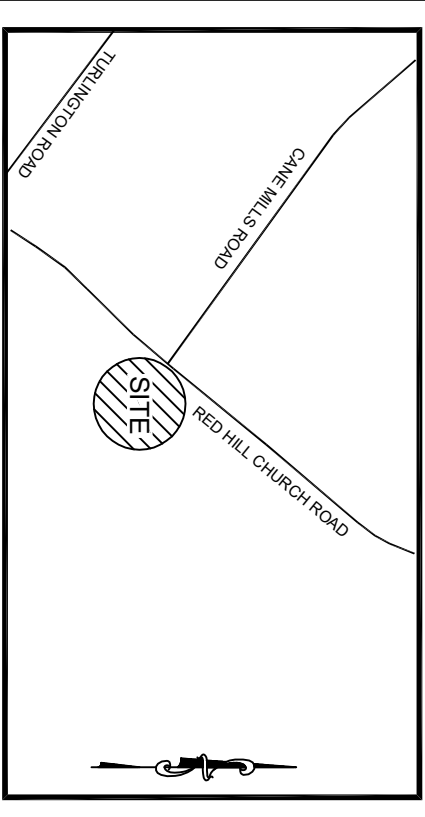

**VICINITY MAP**  
(Not to Scale)

**LEGEND**  
PO = PORCH  
P = PATIO  
SP = SCREENED PORCH OR PATIO  
CP = COVERED PORCH OR PATIO  
WD = WOOD DECK  
SW = SIDEWALK  
DW = CONC DRIVEWAY  
⊗ = COMPUTED POINT  
⊙ = IRON PIPE FOUND  
⊕ = IRON PIPE SET  
⊖ = WATER METER  
⊗ = CLEANOUT  
AC = AIR CONDITIONER  
AG = AIR CONDITONER  
EB = ELECTRIC BOX  
CB = CABLE BOX  
⊠ = TELEPHONE PEDESTAL  
⊙ = LIGHT POLE  
CI = CURB INLET  
YI = YARD INLET  
FH = FIRE HYDRANT  
WV = WATER VALVE  
⊗ = SEWER MANHOLE

**BUILDING SETBACKS:**  
FRONT = 40' ft  
SIDE = 15' ft  
CORNER = 30' ft  
REAR = 30' ft

This map is of an existing parcel of land and is only intended for the parties and purposes shown. This map not for recordation. No title report provided.

BUILDER TO VERIFY HOUSE LOCATION, DIMENSIONS AND REVIEW TOTAL IMPERVIOUS NOTED ON THIS PLOT PLAN

**PRELIMINARY PLOT PLAN**  
FOR



**CANE MILL ESTATES - LOT 16**  
240 PLANTERS LANE, COATS, NC  
GROVE TOWNSHIP, HARNETT COUNTY

DATE: 2/23/21 DRAWN BY: AHB CHECKED BY: SPC  
REFERENCE: MAP# 2006 489-490 PROJECT# 200772 SCALE: 1"=80'