

BUFFINGTON

CANE MILL ESTATES
LOT 14



PLAN ID: 060120.1201

110 VILLAGE TRAIL SUITE 215
WOODSTOCK, GA. 30188

| DRAWING INDEX | |
|---------------|------------------------------|
| A0.0 | COVER SHEET |
| A1.1 | FRONT ELEVATIONS |
| A2.1 | SIDE & REAR ELEVATIONS |
| A3.1 | SLAB FOUNDATIONS |
| A5.1 | FIRST FLOOR PLANS & DETAILS |
| A5.2 | SECOND FLOOR PLANS & DETAILS |
| A6.1 | ROOF PLANS |
| A7.2-A7.3 | ELECTRICAL PLANS |
| A8.1 | TRIM LOCATION LAYOUTS |

| AREA TABULATION | |
|--------------------------|------|
| FIRST FLOOR | 1100 |
| SECOND FLOOR | 1448 |
| TOTAL | 2548 |
| GARAGE | 400 |
| FRONT PORCH (COVERED) | 86 |
| REAR PATIO | 9 |

| PLAN REVISIONS | | | |
|----------------|----|---|---------------------------|
| DATE | BY | REVISION | PAGE # |
| 10/2/2019 | AW | PCR #3254 Reduced island framing depth 1" to accommodate 48" countertop. | A1.5 |
| 10/2/2019 | AW | PCR #3256 showed Obath switches on door adjacent to W.I.C. | A7.3 |
| 10/2/2019 | AW | PCR #3247 Added 3-way switches to Owner's Suite light when optional Laundry door is chosen | A7.3 |
| 10/8/2019 | AW | PCR #3292 moved kitchen light switches over to clear backsplash bullnose on wall adjacent to stairs | A7.2 |
| 10/16/2019 | AW | Revised location for tankless hot water heater | A3.1, A5.1, A7.2 |
| 11/1/2019 | AW | PCR #3314 Relocated switch to attic light for the B&C roof massings | A7.2 |
| 2/26/2020 | AW | PCR #3638 Added 1x10 on front elevations M & T | A1.16, A1.19 |
| 6/1/2020 | MM | PCR #3765 Added note to return veneer ILO siding on second floor returns above front door. | A1.6, A1.11, A1.15, A1.17 |
| 8/11/2020 | AW | Updated elevs M & T to remove cedar columns | A1.16, A1.19 |
| 10/1/2020 | AW | PCR #4084 Removed opt. fireplace in corner location (for 10/1/20 release) | A3.1, A5.1, A7.2, A8.1 |
| 11/6/2020 | MM | Removed overhang at front porch | A1.1-A1.19, A6.1-A6.1.2 |
| 12/1/2020 | MM | Shifted upper run of stairs 2" from landing towards outside of house | A5.1, A5.2 |
| 12/1/2020 | MM | PCR #4239 Changed 2x6 walls at Owner's Bath vanity & WC exterior wall to 2x4 walls | A5.2, A5.2.1 |

| GOVERNMENTAL CODES & STANDARDS |
|--|
| HOME TO BE BUILT TO CONFORM TO ALL APPLICABLE LOCAL CODES, PRACTICES AND STANDARDS |
| BUILDING CODE ANALYSIS / DESIGN CRITERIA |
| HOME TO BE BUILT TO MEET OR EXCEED ALL LOCAL CODES AND DESIGN CRITERIA |

CANE MILL ESTATES LOT 14

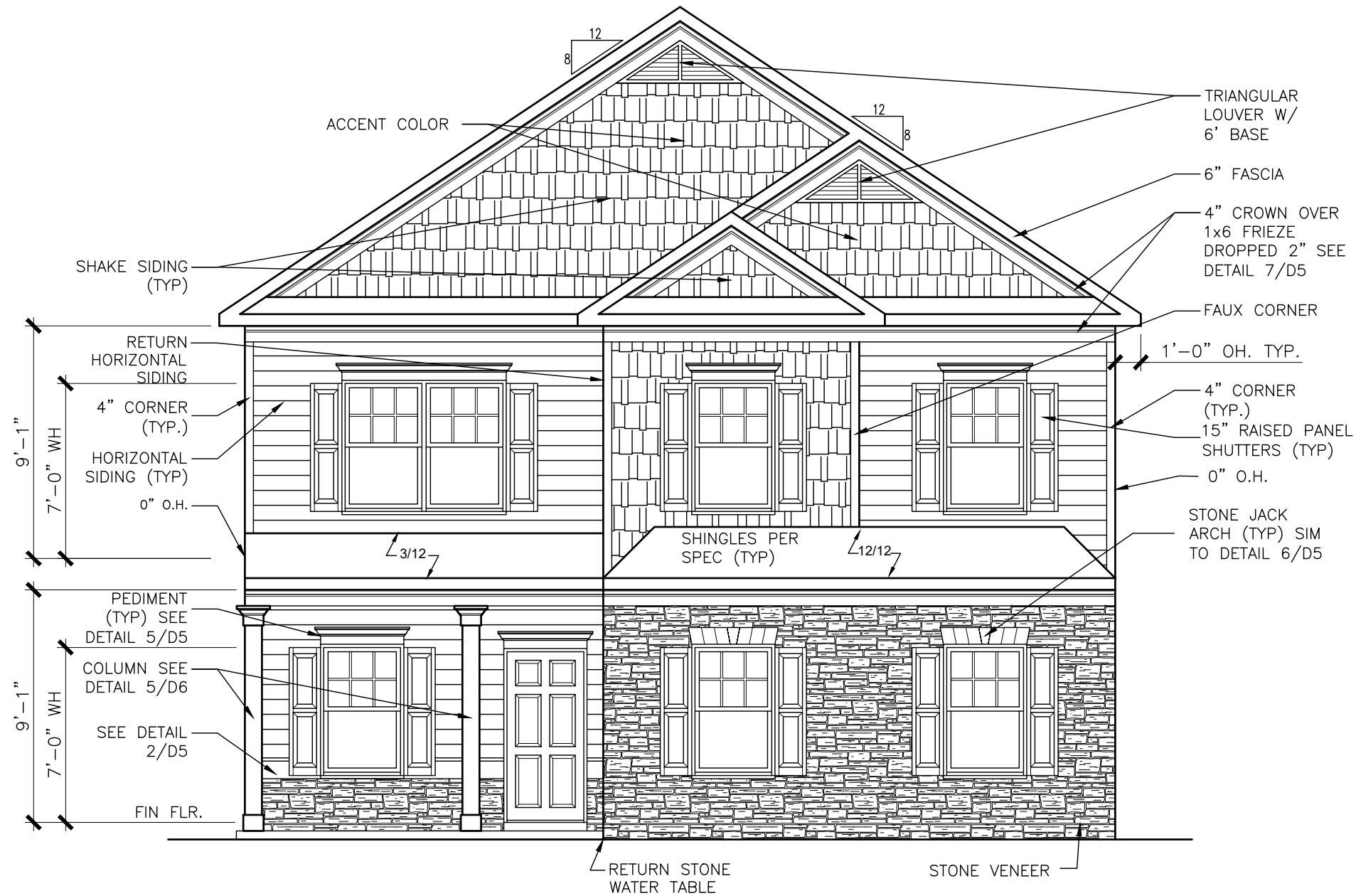

FRONT ELEVATION "B"

SCALE: 1/8" = 1'-0"

ALL NON-MASONRY RETURNS TO
BE HORIZONTAL SIDING

SEE SHEET D3 OF SDH TYPICAL
DETAILS FOR SOFFIT DETAILS PER
SOFFIT MATERIAL

| REV | BY | DATE | REVISION |
|-----|----|------|----------|
| # | # | # | # |
| # | # | # | # |
| # | # | # | # |
| # | # | # | # |
| # | # | # | # |



ELEVATIONS
FRONT ELEVATION
BUFFINGTON

SMITH DOUGLAS HOMES
110 VILLAGE TRAIL
SUITE 115
WOODSTOCK, GA 30188
www.smithdouglas.com

SMITH DOUGLAS HOMES
expressly reserves its
property rights in these
plans and drawings.
These plans and related
drawings are not to be
reproduced without written
consent from SMITH
DOUGLAS HOMES.

| | |
|---------------|---------|
| BY: BB | CHK: AW |
| DATE: 4/2/21 | |
| FACADE OPT: B | |
| PLAN ID: | |
| FND: ALL | ELEV: B |
| PAGE NO: A1.1 | |

CANE MILL ESTATES LOT 14

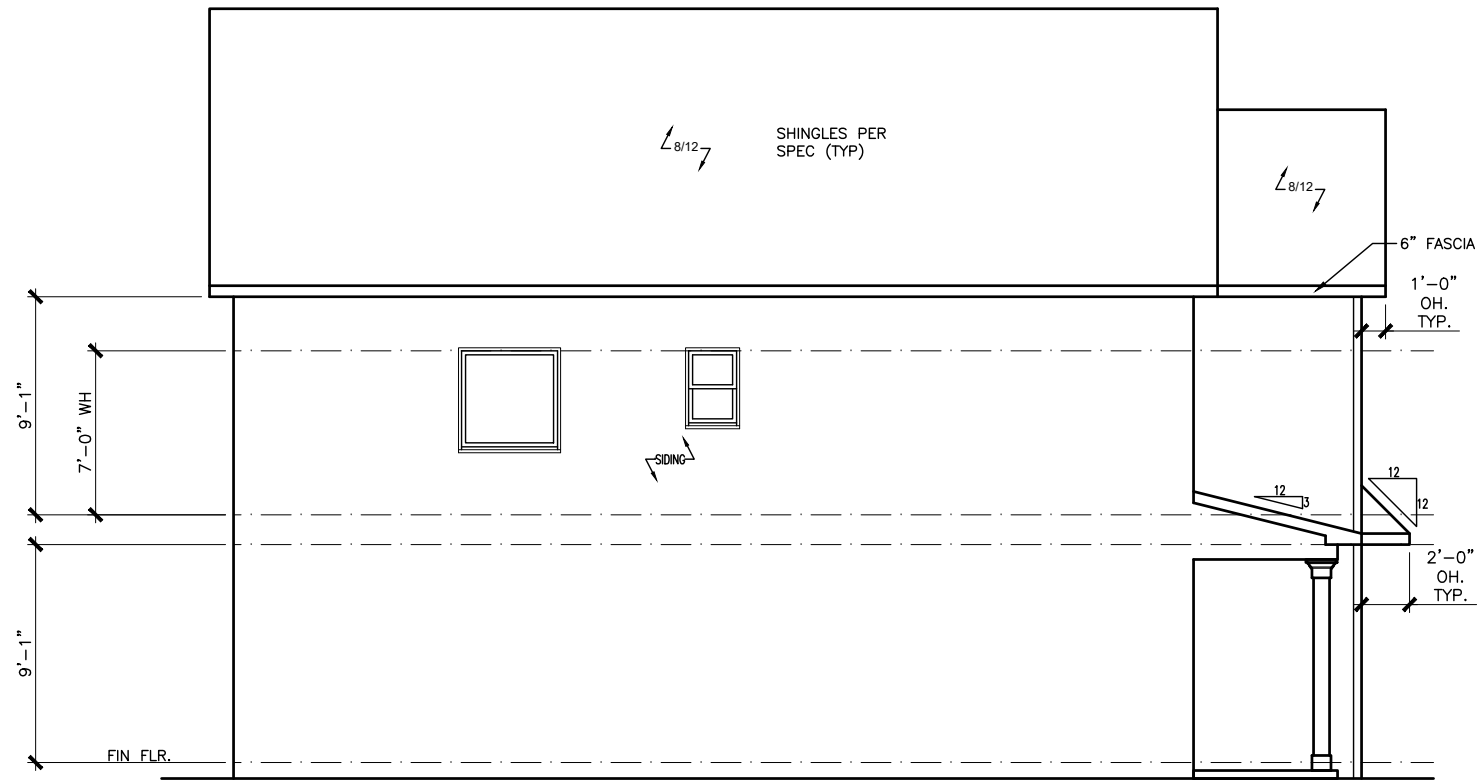

LEFT ELEVATION "B"

SCALE: 1/8" = 1'-0"

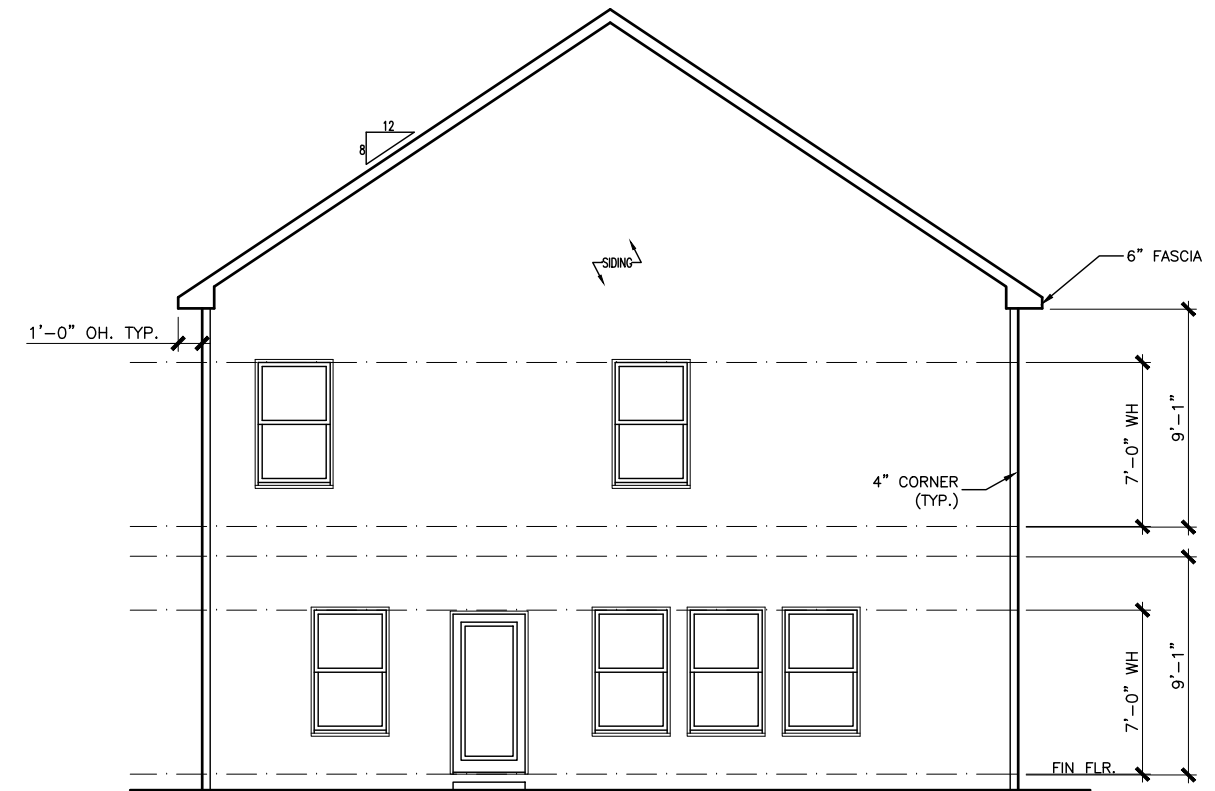

REAR ELEVATION "B"

SCALE: 1/8" = 1'-0"

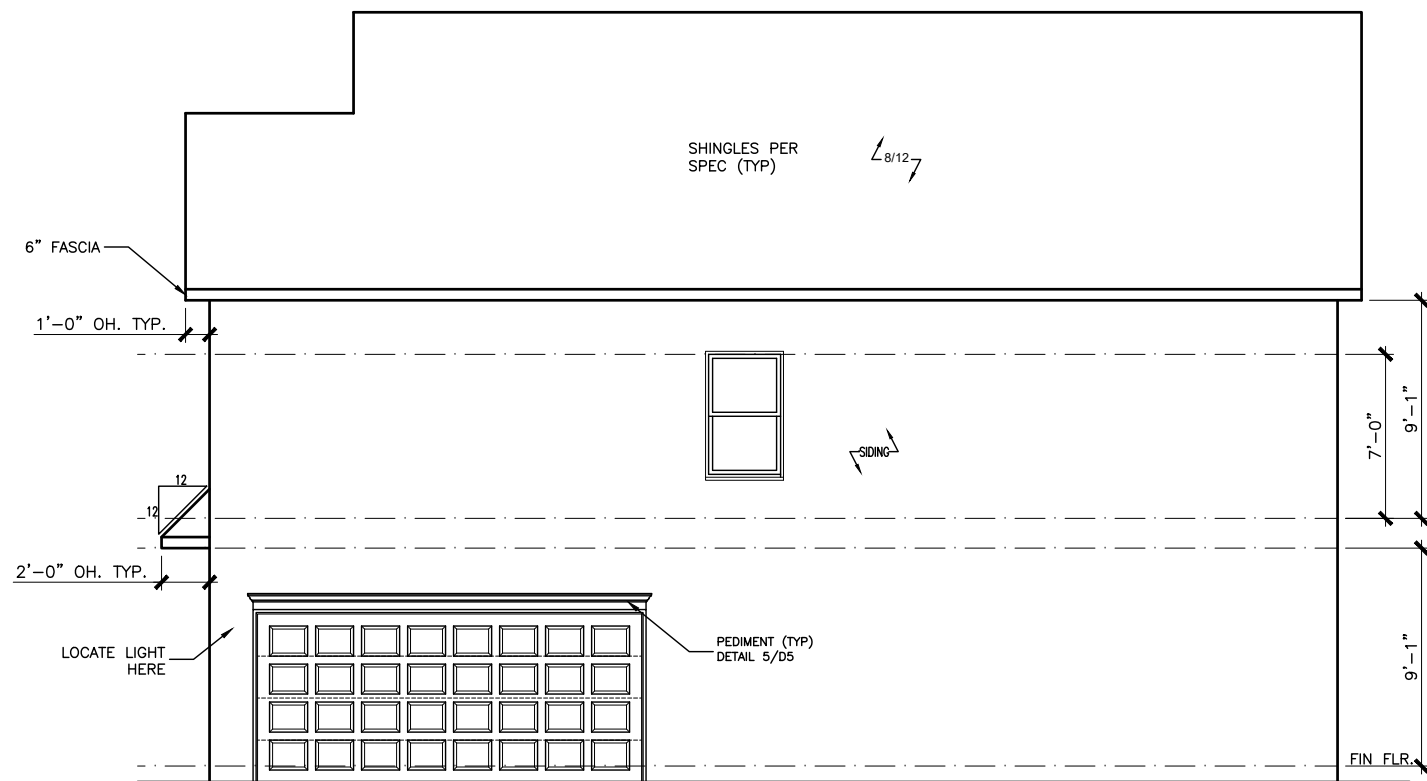

RIGHT ELEVATION "B"

SCALE: 1/8" = 1'-0"

| BY | # | REVISION | DATE |
|----|---|----------|------|
| | | | |
| | | | |
| | | | |
| | | | |
| | | | |



ELEVATIONS
SIDES AND REAR
BUFFINGTON

SMITH DOUGLAS HOMES
110 VILLAGE TRAIL
SUITE 115
WOODSTOCK, GA 30188
www.smithdouglas.com

SMITH DOUGLAS HOMES expressly reserves its property rights in these plans and drawings. These plans and related drawings are not to be reproduced without written consent from SMITH DOUGLAS HOMES.

| | |
|---------------|---------|
| BY: BB | CHK: AW |
| DATE: 4/2/21 | |
| FACADE OPT: B | |
| PLAN ID: | |
| FND: ALL | ELEV: B |
| PAGE NO: A2.1 | |

CANE MILL ESTATES LOT 14

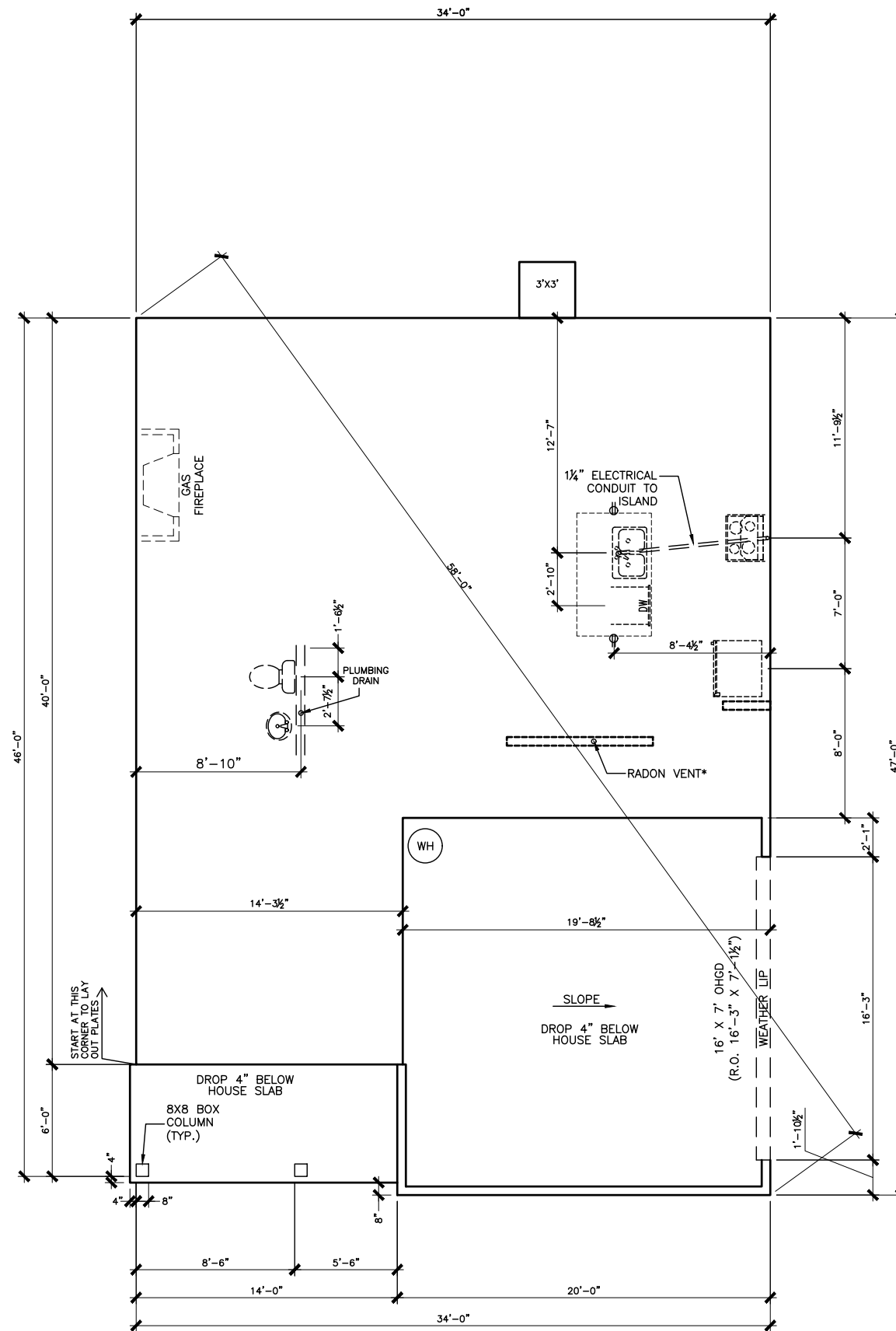

*RADON VENT PROVIDED
PER LOCAL CODE

REFER TO DETAIL 3/D1
FOR BRICK LEDGE
DETAIL WHEN BRICK
VENEER IS CHOSEN

SLAB PLAN

SCALE: 1/8" = 1'-0"

| DATE | REVISION | BY |
|------|----------|----|
| | | |
| | | |
| | | |
| | | |
| | | |



FOUNDATION PLAN
SLAB PLAN
BUFFINGTON

SMITH DOUGLAS HOMES
110 VILLAGE TRAIL
SUITE 115
WOODSTOCK, GA 30188
www.smithdouglas.com

SMITH DOUGLAS HOMES
expressly reserves its
property rights in these
plans and drawings.
These plans and related
drawings are not to be
reproduced without written
consent from SMITH
DOUGLAS HOMES.

| | |
|---------------|---------|
| BY: BB | CHK: AW |
| DATE: 4/2/21 | |
| FACADE OPT: B | |
| PLAN ID: | |
| FND: ALL | ELEV: B |
| PAGE NO: A3.1 | |

CANE MILL ESTATES LOT 14

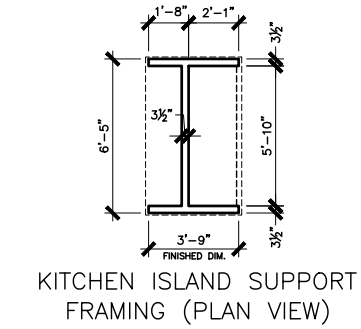
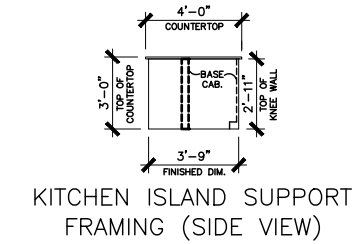
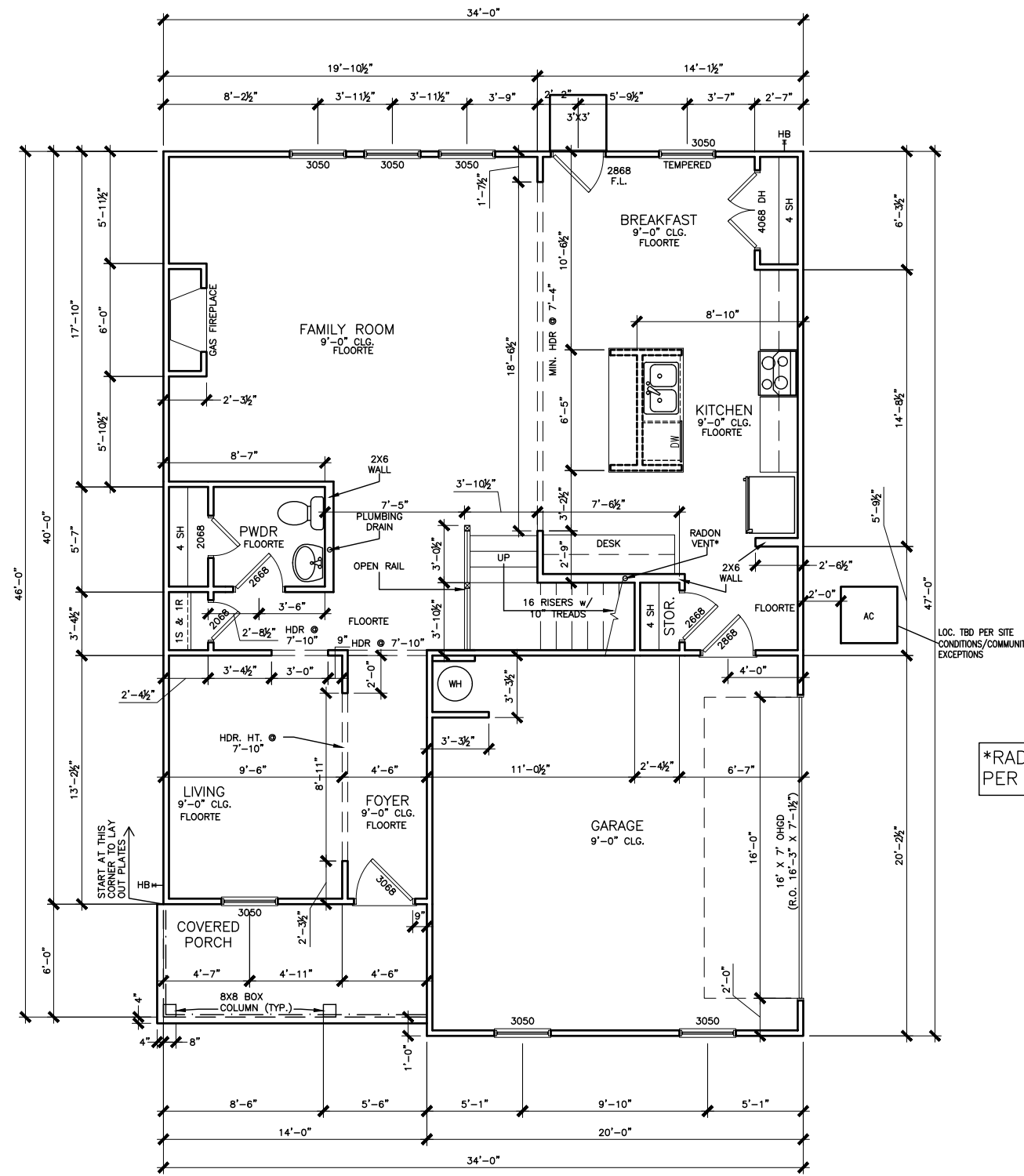

FIRST FLOOR PLAN
SCALE: 1/8" = 1'-0"

| BY | REVISION | DATE |
|----|----------|------|
| # | # | # |
| # | # | # |
| # | # | # |
| # | # | # |
| # | # | # |
| # | # | # |

SMITH DOUGLAS HOMES
QUALITY | INTEGRITY | VALUE

FLOOR PLAN
FIRST FLOOR
BUFFINGTON

SMITH DOUGLAS HOMES
110 VILLAGE TRAIL
SUITE 115
WOODSTOCK, GA 30188
www.smithdouglas.com

SMITH DOUGLAS HOMES expressly reserves its property rights in these plans and drawings. These plans and related drawings are not to be reproduced without written consent from SMITH DOUGLAS HOMES.

| | |
|---------------|---------|
| BY: BB | CHK: AW |
| DATE: 4/2/21 | |
| FACADE OPT: B | |
| PLAN ID: | |
| FND: ALL | ELEV: B |
| PAGE NO: A5.1 | |

CANE MILL ESTATES LOT 14

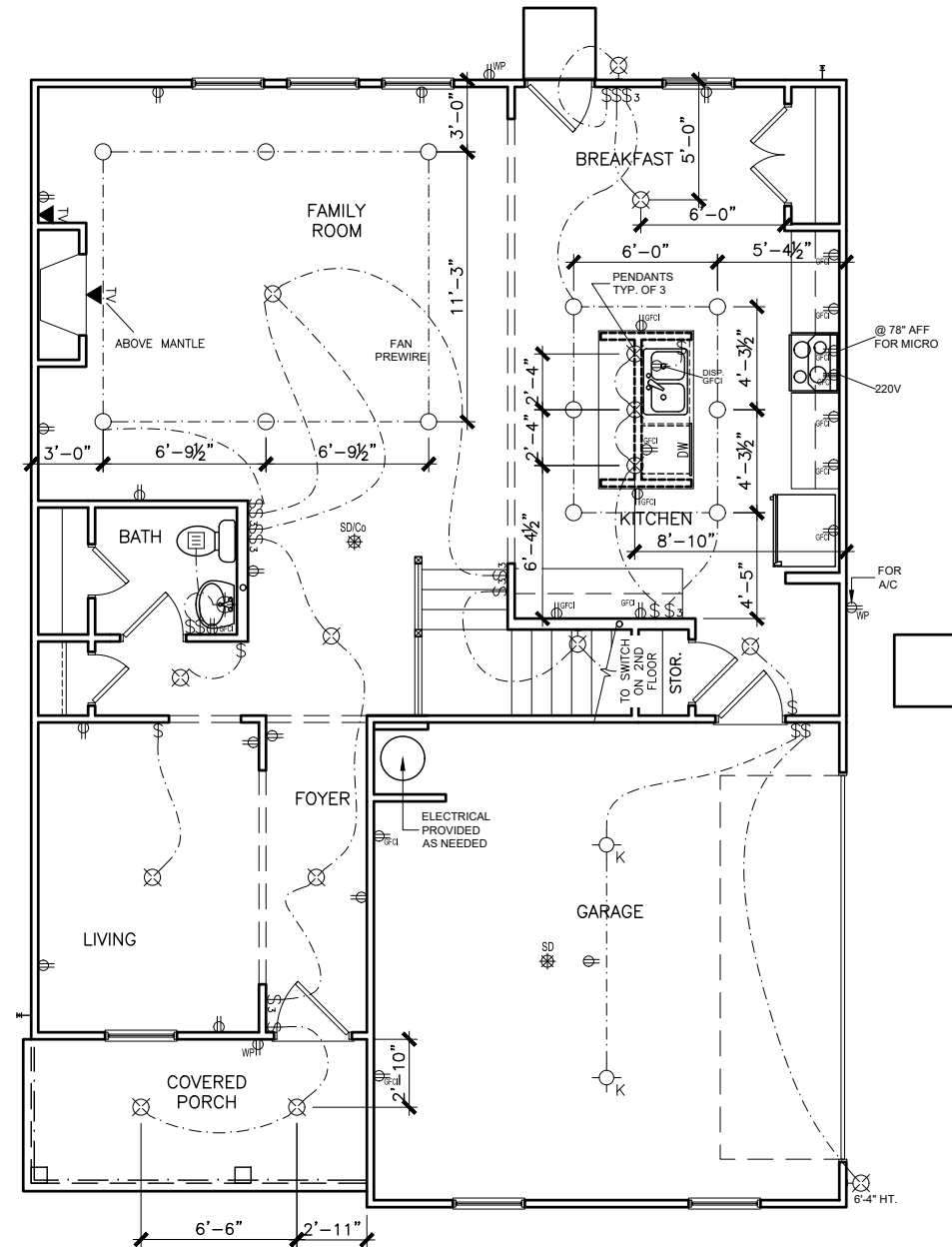

ELECTRICAL LEGEND

| | | | |
|----------------|----------------------------------|-------------------|--------------------------------|
| \$ | SWITCH | TV | TV |
| \$3 | 3 WAY SWITCH | ⊕ | 120V RECEPTACLE |
| \$4 | 4 WAY SWITCH | ⊕ | 120V SWITCHED RECEPTACLE |
| ⊗ | CEILING FIXTURE | ⊕ | 220V RECEPTACLE |
| ⊕ _K | KEYLESS | ⊕ _{GFCI} | GFCI OUTLET |
| ⊗ | WALL MOUNT FIXTURE | ⊕ _{AFCI} | ARCH FAULT CIRCUIT INTERRUPTER |
| ○ | CEILING FIXTURE | † _{GL} | GAS LINE |
| ● | FLEX CONDUIT | † _{WL} | WATER LINE |
| CH | CHIMES | ⊥ | HOSE BIBB |
| PH | TELEPHONE | ⊕ | FLOOD LIGHT |
| SD/Co | SMOKE DETECTOR & CARBON MONOXIDE | ⊕ | 1x4 LUMINOUS FIXTURE |
| SO | SECURITY OUTLET | ⊗ | CEILING FAN |
| □ | GARAGE DOOR OPENER | — | ELECTRICAL WIRING |
| ⊕ | EXHAUST FAN | ⊕ | CEILING FIXTURE |
| ⊕ | FAN/LIGHT | | |

ELECTRICAL PLANS TO FOLLOW ALL LOCAL CODES

APPROX. FIXTURE HGTS (MEASURED FROM BOTTOM OF FIXTURE)

| | |
|-------------------------|--------------------------|
| BREAKFAST/DINING ROOM | 63" ABOVE FINISHED FLOOR |
| KITCHEN PENDANT LIGHTS | 33" ABOVE COUNTER TOP |
| TWO STORY FOYER FIXTURE | 96" ABOVE FINISHED FLOOR |
| CEILING FAN | 96" ABOVE FINISHED FLOOR |

NOTE: FINAL PLACEMENT OF PHONE/CABLE T.B.D. ON SITE BY THE BUILDER

FIRST FLOOR ELECTRICAL PLAN

SCALE: 1/8" = 1'-0"

| | | | | | |
|----------|---|---|---|---|---|
| BY | # | # | # | # | # |
| REVISION | | | | | |
| DATE | | | | | |



ELECTRICAL PLAN
FIRST FLOOR
BUFFINGTON

SMITH DOUGLAS HOMES
110 VILLAGE TRAIL
SUITE 115
WOODSTOCK, GA 30188
www.smithdouglas.com

SMITH DOUGLAS HOMES expressly reserves its property rights in these plans and drawings. These plans and related drawings are not to be reproduced without written consent from SMITH DOUGLAS HOMES.

| | | | |
|-------------|--------|-------|----|
| BY: | BB | CHK: | AW |
| DATE: | 4/2/21 | | |
| FACADE OPT: | B | | |
| PLAN ID: | | | |
| FND: | ALL | ELEV: | B |
| PAGE NO: | A7.2 | | |

CANE MILL ESTATES LOT 14

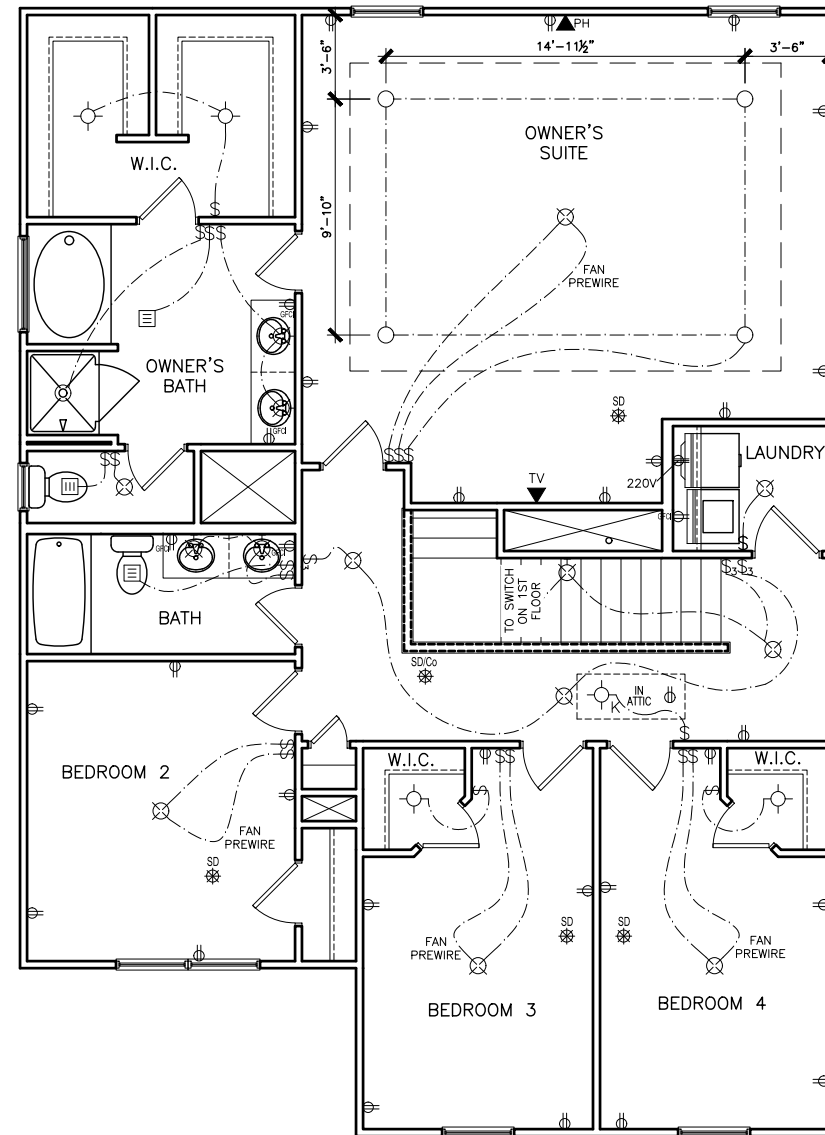

| ELECTRICAL LEGEND | | | |
|-------------------|----------------------------------|----|--------------------------------|
| \$ | SWITCH | TV | TV |
| \$3 | 3 WAY SWITCH | ⊕ | 120V RECEPTACLE |
| \$4 | 4 WAY SWITCH | ⊕ | 120V SWITCHED RECEPTACLE |
| ⊗ | CEILING FIXTURE | ⊕ | 220V RECEPTACLE |
| ⊕ | KEYLESS | ⊕ | GFCI OUTLET |
| ⊗ | WALL MOUNT FIXTURE | ⊕ | ARCH FAULT CIRCUIT INTERRUPTER |
| ○ | CEILING FIXTURE | † | GAS LINE |
| ● | FLEX CONDUIT | † | WATER LINE |
| CH | CHIMES | ⊥ | HOSE BIBB |
| PH | TELEPHONE | ⊕ | FLOOD LIGHT |
| SD/Co | SMOKE DETECTOR & CARBON MONOXIDE | ⊕ | 1x4 LUMINOUS FIXTURE |
| SO | SECURITY OUTLET | ⊕ | CEILING FAN |
| □ | GARAGE DOOR OPENER | — | ELECTRICAL WIRING |
| ⊕ | EXHAUST FAN | ⊕ | CEILING FIXTURE |
| ⊕ | FAN/LIGHT | | |

ELECTRICAL PLANS TO FOLLOW ALL LOCAL CODES

APPROX. FIXTURE HGTS (MEASURED FROM BOTTOM OF FIXTURE)

| | |
|-------------------------|--------------------------|
| BREAKFAST/DINING ROOM | 63" ABOVE FINISHED FLOOR |
| KITCHEN PENDANT LIGHTS | 33" ABOVE COUNTER TOP |
| TWO STORY FOYER FIXTURE | 96" ABOVE FINISHED FLOOR |
| CEILING FAN | 96" ABOVE FINISHED FLOOR |

NOTE: FINAL PLACEMENT OF PHONE/CABLE T.B.D. ON SITE BY THE BUILDER

| BY | # | REVISION | DATE |
|----|---|----------|------|
| | | | |
| | | | |
| | | | |
| | | | |



ELECTRICAL PLAN
SECOND FLOOR
BUFFINGTON

SMITH DOUGLAS HOMES
110 VILLAGE TRAIL
SUITE 115
WOODSTOCK, GA 30188
www.smithdouglas.com

SMITH DOUGLAS HOMES expressly reserves it's property rights in these plans and drawings. These plans and related drawings are not to be reproduced without written consent from SMITH DOUGLAS HOMES.

| | |
|---------------|---------|
| BY: BB | CHK: AW |
| DATE: 4/2/21 | |
| FACADE OPT: B | |
| PLAN ID: | |
| FND: ALL | ELEV: B |
| PAGE NO: A7.3 | |

SECOND FLOOR ELECTRICAL PLAN
SCALE: 1/8" = 1'-0"

CANE MILL ESTATES LOT 14

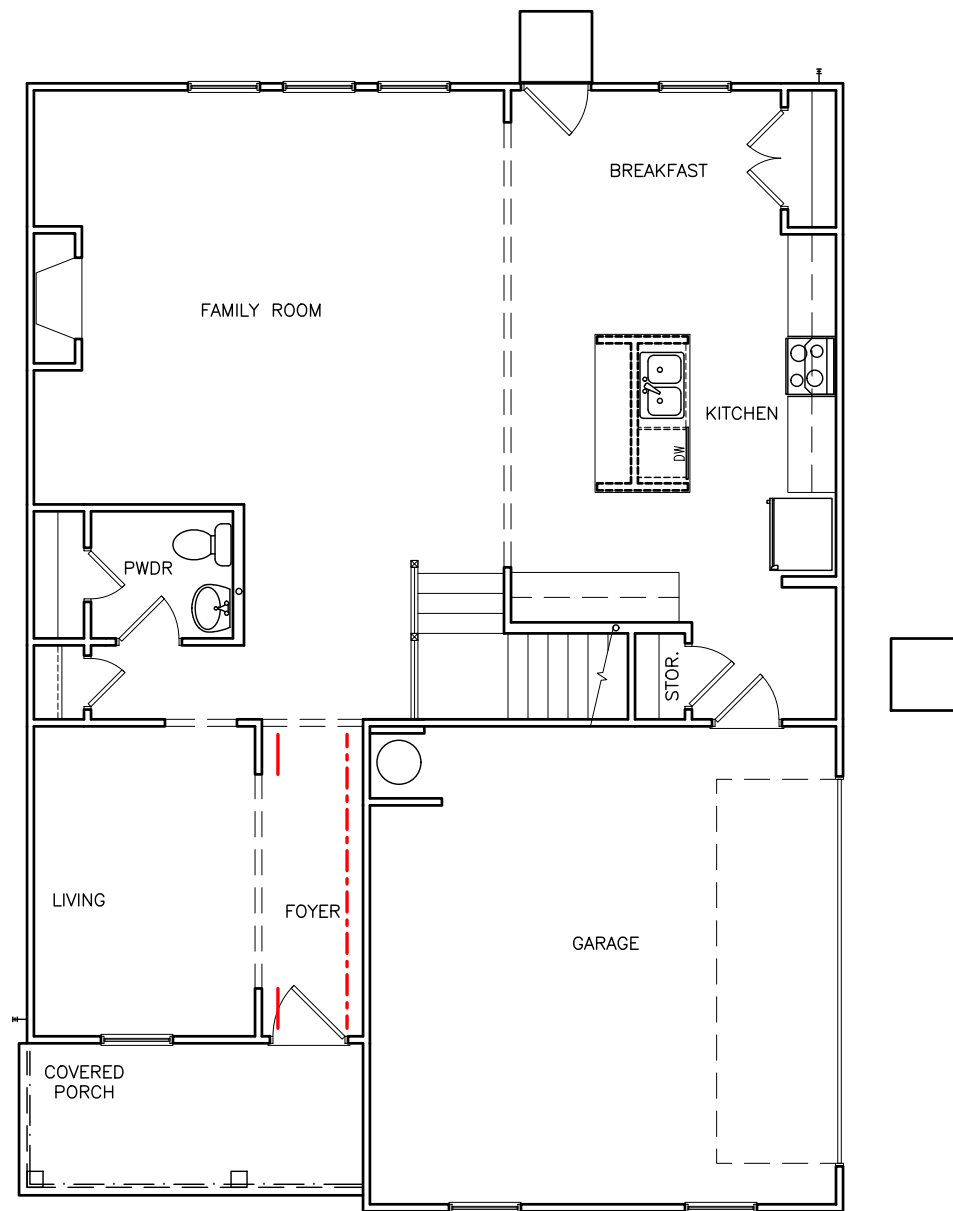

----- Foyer TRIM - CHAIR/SHADOW

TRIM LAYOUT FIRST FLOOR PLAN

SCALE : 1/8" = 1'-0"

| DATE | REVISION | BY |
|------|----------|----|
| # | # | # |
| # | # | # |
| # | # | # |
| # | # | # |
| # | # | # |



FLOOR PLAN
TRIM LAYOUT
BUFFINGTON

SMITH DOUGLAS HOMES
110 VILLAGE TRAIL
SUITE 115
WOODSTOCK, GA 30188
www.smithdouglas.com

SMITH DOUGLAS HOMES expressly reserves its property rights in these plans and drawings. These plans and related drawings are not to be reproduced without written consent from SMITH DOUGLAS HOMES.

| | |
|---------------|---------|
| BY: BB | CHK: AW |
| DATE: 4/2/21 | |
| FACADE OPT: B | |
| PLAN ID: | |
| FND: ALL | ELEV: B |
| PAGE NO: A8.1 | |

CANE MILL ESTATES LOT 14

| Lot Definition | | |
|--|--|-----------------|
| Project: Cane Mill Estates Building: 000 Unit: 0014 | Community: Cane Mill Estates Builder: Thomas Kenneth Barlow Status: Sold | |
| Plan: Buffington B Side Entry Orientation: Garage Right Bedrooms: 4 Address: 302 Planters Lane Coats NC 27521 | RTeam: Raleigh West Sq. Ft: 2,548 Bathrooms: 2.5 Permit: Notes: | |
| Sales Data | Dates | |
| Contract: 88913 Buyer: Jahsiale Williams Sales Agent: Sam Fulmer | Ratified: 03/27/2021 Original Start: 03/29/2021 Start: 03/29/2021 Scheduled Complete: 08/09/2021 | |
| Option | Description | Quantity |
| 1 Ceiling Fixture Light Wet or Dry | Add One Low Profile Flush Mount LED Light on One Single Switch. This Option can be used in a Wet or Dry Location. Locations to be noted on exhibit for Electrician. NOTE: Option cannot be used to replace light fixtures at a specific location. | 1 |
| 36" Cabinet (0) Standard | Note: Bath cabinets to match | 1 |
| Additional Cable Outlet | | 1 |
| Automatic Garage Door Opener | Garage Door Opener - Per Door | 1 |
| Blind for Rear/Back Door | Blinds - Additional blind to cover rear/back door. | 1 |
| Blind per Optional 3050 Single Window | One 3050 blind. For use when you've added a 3050 optional window. See Optional Windows Sales Guide on the Process Model for assistance. | 1 |
| Blinds for Base House | Includes blinds for all standard windows on front, sides, and rear that are operational and accessible. Does not include blinds for any optional windows, including windows for optional second floors. | 1 |
| Chrome Interior Finish Color Package | Includes chrome kitchen faucet, bath faucets, & fixtures, brushed nickel door hardware (hinges, bumps, knobs/levers, deadbolts), Pkg1 (two) lighting fixtures, & pewter oval mirror. Separate options also affected: shower door, bath hardware (towel bar/ring, tp holder), shower grab bar, cabinet hardware | 1 |
| Decorative 4040 Picture Window | Replace clear 4040 Window over Master Garden Tub with Decorative 4040 Picture Window. NOTE: This option cannot be used with the large fig shower option, the large tile shower option, or on any plan/jobs that otherwise does not have a 4040 clear window over Master Garden Tub. | 1 |
| Family/Great Room Ceiling Fixture Lights | Family/Great Room Lights - Low Profile Flush Mount LED Lights per plan. | 1 |
| User Name: Victoria Wicker 1 of 3 04/01/2021 09:26:56 AM Database: SmithDouglasCommunities | | |

| Lot Definition | | |
|---|---|---|
| Fireplace in Family Room - Gas | | 1 |
| FIPkg 5AA-Floorte Pro, StdCpt (FIPkg1) | Flooring Package 5AA - Floorte Pro, Standard Carpet (from Package 1). SPC (solid polymer core) 0.5 mm vinyl top layer plank | 1 |
| FirPkg Opt-Powder Floorte Pro | Flooring Package - Option Powder Room LVP SPC (solid polymer core) 0.5 mm vinyl top layer plank | 1 |
| Foyer - Chair Rail/Shadow Box | | 1 |
| Granite-Kitchen Countertops - Lvl 1 (0) | Kitchen Granite Countertops - Level 1 where Laminite is Std. | 1 |
| Granite-Kitchen Sink Level 1 | Level 1 Undermount rectangular stainless steel sink upgrade for kitchen granite. | 1 |
| G-Tub & PF Shower FD OBATHC | (Garden tub and separate shower with framed door ILO of Large prefab shower - (obathc)) | 1 |
| Hall Bath Marble 1 Double Ilo LamSgl | ***Includes Vanity Double Bowl Option Do Not Select Both*** | 1 |
| Kitchen Ceiling Fixture Lights ILO Std | Kitchen Lights - Low Profile Flush Mount LED Lights per Plan ILO Standard Light. | 1 |
| Level 2 - Package Electric (from E1) | Frigidaire SS 24" Dishwasher*** Frigidaire SS 1.8 Cu. Ft. Micro Frigidaire SS 30" Elec Range | 1 |
| Open Rail 1st Floor - Iron | | 1 |
| Owner Bath Marble 1 Double Ilo LamSgl | ***Includes Vanity Double Bowl Option Do Not Select Both*** | 1 |
| Owner Bath Water Closet Window | 2030 Single Window for Owner Bath Water Closet. NOTE: Blind not included. | 1 |
| Owner's Bedroom Ceiling Fixture Lights | Owner's Bedroom Lights - 4 Low Profile Flush Mount LED Lights. | 1 |
| Paint Interior Ceiling White | | 1 |
| Paint Wall/Ceiling Color Upgrade | Upgrade Interior Paint Color on Walls and Ceilings for the whole house in lieu of base color | 1 |
| Pendant Lights per Plan | Pendant Lights above Island/Bar Top per plan electrical diagram. To match lighting package selected. NOTE: Choose this option only once. | 1 |
| PreWire for Ceiling Fan | Pre-wire a light location for a future ceiling fan. | 3 |
| Screen Per Optional 3050 Window | Note: If the optional window is a 3050 twin, it needs two screens. | 1 |
| Screens Base House Single Family | Add window screens to all operable standard windows on single family home. NOTE: Does not include screens for windows for optional 2nd-floors, side entry garage, or windows added or changed from structural options, optional windows, or basement windows. See additional options to complete screens. | 1 |
| Stone 20 A ExtCoPkg(f) | | 1 |
| Tray Ceiling - Owner's Bedroom | | 1 |
| Window in Hallway | Optional Window in Hallway. Does not include Blind. | 1 |
| User Name: Victoria Wicker 2 of 3 04/01/2021 09:26:56 AM Database: SmithDouglasCommunities | | |

| Lot Definition | | |
|---|---------------------------------|---|
| Activity | Description | Selection Description |
| Del&Install AppliancePkg | Appliance Package Select - All | Appliance Package Selected |
| Deliver & Install Blinds | Blind Color | White |
| Deliver Windows-FirstOut | 4040 Decorative Privacy Window | Prairie DF4747PRAI |
| Install Cabinets Complet | Cabinet Finish - Standard Arts | Standard-Sinclair Birch- Saddle |
| Install Cabinets Complet | Secondary Bath Vanity Tops-All | Selection not Needed |
| Install Carpet | Carpet - Standard ALL | Smith Grove II Trade Wind 00502 |
| Install Floorte Pro (LP) | Floorte Pro 1stLggr ALL | Presto Plus - 509 Washed Oak |
| Install Granite Tops | RDU Granite Counter/KitchenLvl1 | Dalile-New Caledonia |
| Install Granite Tops | Rectangular SS sink LVL 1 | 5050 Double Bowl Sink |
| Install Marble Tops | RDU Marble Vanity Top Lvl 1 | Matte-#153 White w/ice Grey w/oval bowl |
| Paint Interior Complete | Interior Paint (Walls) - Upgrd | SW 7029 Agreeable Gray |
| PM Install Vinyl Floor | VinylPkg-Owner Bath | Highlands Stronghold 529 |
| PM Install Vinyl Floor | VinylPkg-Std 2nd Baths/Laundry | Highlands Stronghold 529 |
| Stain Handrails | Hand Rail Stain - All | MW-Toasted Barrel [LVP-509 Washed Oak] |
| User Name: Victoria Wicker 3 of 3 04/01/2021 09:26:56 AM Database: SmithDouglasCommunities | | |

| BY | # | DATE | REVISION |
|----|---|------|----------|
| | | | |
| | | | |
| | | | |
| | | | |
| | | | |



DETAILS
LOT DEFINITION
BUFFINGTON

SMITH DOUGLAS HOMES
110 VILLAGE TRAIL
SUITE 115
WOODSTOCK, GA 30188
www.smithdouglas.com

SMITH DOUGLAS HOMES expressly reserves its property rights in these plans and drawings. These plans and related drawings are not to be reproduced without written consent from SMITH DOUGLAS HOMES.

| | |
|---------------|---------|
| BY: BB | CHK: AW |
| DATE: 4/2/21 | |
| FACADE OPT: B | |
| PLAN ID: | |
| FND: ALL | ELEV: B |
| PAGE NO: A9.1 | |

GENERAL STRUCTURAL NOTES:

- The design professional whose seal appears on these drawings is the structural engineer of record (SER) for this project. The SER bears the responsibility of the primary structural elements and the performance of this structure. No other party may revise, alter, or delete any structural aspects of these construction documents without written permission of SUMMIT Engineering, Laboratory & Testing, P.C. (SUMMIT) or the SER. For the purposes of these construction documents the SER and SUMMIT shall be considered the same entity.
- The structure is only stable in its completed form. The contractor shall provide all required temporary bracing during construction to stabilize the structure.
- The SER is not responsible for construction sequences, methods, or techniques in connection with the construction of this structure. The SER will not be held responsible for the contractor's failure to conform to the contract documents, should any non-conformities occur.
- Any structural elements or details not fully developed on the construction drawings shall be completed under the direction of a licensed professional engineer. These shop drawings shall be submitted to SUMMIT for review before any construction begins. The shop drawings will be reviewed for overall compliance as it relates to the structural design of this project. Verification of the shop drawings for dimensions, or for actual field conditions, is not the responsibility of the SER or SUMMIT.
- Verification of assumed field conditions is not the responsibility of the SER. The contractor shall verify the field conditions for accuracy and report any discrepancies to SUMMIT before construction begins.
- The SER is not responsible for any secondary structural elements or non-structural elements, except for the elements specifically noted on the structural drawings.
- This structure and all construction shall conform to all applicable sections of the international residential code.
- This structure and all construction shall conform to all applicable sections of the 2018 North Carolina Residential Code (NCR) and any local codes or restrictions

FOUNDATIONS:

- Foundations shall be constructed in accordance with chapter 4 of the 2018 NC Residential Building Code (Special consideration shall be given to Chapter 45 in wind zones above 130mph)
- Footings sizes based on a presumptive soil bearing capacity of 2000 PSF. Contractor is solely responsible for verifying the suitability of the site soil conditions at the time of construction
- Maximum depth of unbalanced fill against masonry walls to be as specified in section R404.1 of the 2018 NCR
- The structural engineer has not performed a subsurface investigation. Verification of this assumed value is the responsibility of the owner or the contractor. Should any adverse soil condition be encountered the SER must be contacted before proceeding.
- The bottom of all footings shall extend below the frost line for the region in which the structure is to be constructed. However, the bottom of all footings shall be a minimum of 12" below grade.
- Any fill shall be placed under the direction or recommendation of a licensed professional engineer. The resulting soil shall be compacted to a minimum of 95% maximum dry density.
- Excavations of footings shall be lined temporarily with a 6 mil polyethylene membrane if placement of concrete does not occur within 24 hours of excavation.
- No concrete shall be placed against any subgrade containing water, ice, frost, or loose material.
- Each crawl space pier shall bear in the middle third of its respective footing and each girder shall bearing in the middle third of the piers. Plasters to be bonded to perimeter foundation wall
- Crawl spaced to be graded level and clear of all debris
- Provide foundation waterproofing and drain with positive slope to outlet as required by site conditions
- Energy efficiency compliance and insulation of the structure to be in accordance with chapter 11 of the 2018 NCR

CONCRETE:

- Concrete shall have a normal weight aggregate and a minimum compressive strength (f'c) at 28 days of 3000 psi, unless otherwise noted on the plan.
- Concrete shall be proportioned, mixed, and placed in accordance with the latest editions of ACI 318: "Building Code Requirements for Reinforced Concrete" and ACI 301: "Specifications for Structural Concrete for Buildings".
- Air entrained concrete must be used for all structural elements exposed to freeze/thaw cycles and deicing chemicals. Air entrainment amounts (in percent) shall be within -1% to +2% of target values as follows:
 - Footings: 5%
 - Exterior Slabs: 5%
- No admixtures shall be added to any structural concrete without written permission of the SER
- Concrete slabs-on-grade shall be constructed in accordance with ACI 302.1R-96: "Guide for Concrete Slab and Slab Construction".
- The concrete slab-on-grade has been designed using a subgrade modulus of k=250 pci and a design loading of 200 psf. The SER is not responsible for differential settlement, slab cracking or other future defects resulting from unreported conditions not in accordance with the above assumptions.
- Control or saw cut joints shall be spaced in interior slabs-on-grade at a maximum of 15'-0" O.C. and in exterior slabs-on-grade at a maximum of 10'-0" unless otherwise noted.
- Control or saw cut joints shall be produced using conventional process within 4 to 12 hours after the slab has been finished
- Reinforcing steel may not extend through a control joint. Reinforcing steel may extend through a saw cut joint.
- All welded wire fabric (W.W.F.) for concrete slabs-on-grade shall be placed at mid-depth of slab. The W.W.F. shall be securely supported during the concrete pour. Fibermesh may be used in lieu of W.W.F.

CONCRETE REINFORCEMENT:

- Fibrous concrete reinforcement, or fibermesh, specified in concrete slabs-on-grade may be used for control of cracking due to shrinkage and thermal expansion/contraction, lowered water migration, an increase in impact capacity, increased abrasion resistance, and residual strength.
- Fibermesh reinforcing to be 100% virgin polypropylene fibers containing no reprocessed olefin materials and specifically manufactured for use as concrete secondary reinforcement.
- Application of fibermesh per cubic yard of concrete shall equal a minimum of 0.1% by volume (1.5 pounds per cubic yard)
- Fibermesh shall comply with ASTM C1116, any local building code requirements, and shall meet or exceed the current industry standard.
- Steel Reinforcing bars shall be new billet steel conforming to ASTM A615, grade 60.
- Detailing, fabrication, and placement of reinforcing steel shall be in accordance with the latest edition of ACI 315: "Manual of Standard Practice for Detailing Concrete Structures"
- Horizontal footing and wall reinforcement shall be continuous and shall have 90° bends, or corner bars with the same size/spacing as the horizontal reinforcement with a class B tension splice.
- Lap reinforcement as required, a minimum of 40 bar diameters for tension or compression unless otherwise noted. Splices in masonry shall be a minimum of 48 bar diameters.
- Where reinforcing dowels are required, they shall be equivalent in size and spacing to the vertical reinforcement. The dowel shall extend 48 bar diameters vertically and 20 bar diameters into the footing.
- Where reinforcing steel is required vertically, dowels shall be provided unless otherwise noted.

WOOD FRAMING:

- Solid sawn wood framing members shall conform to the specifications listed in the latest edition of the "National Design Specification for Wood Construction" (NDS). Unless otherwise noted, all wood framing members are designed to be Spruce-Pine-Fir (SPF) #2.
- LVL or PSL engineered wood shall have the following minimum design values:
 - E = 1,900,000 psi
 - Fb = 2600 psi
 - Fv = 285 psi
 - Fc = 700 psi
- Wood in contact with concrete, masonry, or earth shall be pressure treated in accordance with AWPA standard C-15. All other moisture exposed wood shall be treated in accordance with AWPA standard C-2
- Nails shall be common wire nails unless otherwise noted.
- Lag screws shall conform to ANSI/ASME standard B18.2.1-1981. Lead holes for lag screws shall be in accordance with NDS specifications.
- All beams shall have full bearing on supporting framing members unless otherwise noted.
- Exterior and load bearing stud walls are to be 2x4 SPF#2 @16" O.C. unless otherwise noted. Studs shall be continuous from the sole plate to the double top plate. Studs shall only be discontinuous at headers for window/door openings. A minimum of one king stud shall be placed at each end of the header. King studs shall be continuous.
- Individual studs forming a column shall be attached with one 10d nail @6" O.C. staggered. The stud column shall be continuous to the foundation or beam. The column shall be fully blocked at all floor levels to ensure proper load transfer.
- Multi-ply beams shall have each ply attached with (3)10d nails @ 24" O.C.
- Fitth beams and four and five ply beams shall be bolted together with (2) rows of 1/2" dia. through bolts staggered @24" O.C. w/ 2" edge distance and (2) bolts located at 6" from each end, unless noted otherwise.

WOOD TRUSSES:

- The wood truss manufacturer/fabricator is responsible for the design of the wood trusses. Submit sealed shop drawings and supporting calculations to the SER for review prior to fabrication. The SER shall have a minimum of five (5) days for review. The review by the SER shall review for overall compliance with the design documents. The SER shall assume no responsibility for the correctness for the structural design for the wood trusses.
- The wood trusses shall be designed for all required loadings as specified in the local building code, the ASCE Standard "Minimum Design Loads for Buildings and Other Structures." (ASCE 7-10), and the loading requirements shown on these specifications. The truss drawings shall be coordinated with all other construction documents and provisions provided for loads shown on these drawings including but not limited to HVAC equipment, piping, and architectural fixtures attached to the trusses.
- The trusses shall be designed, fabricated, and erected in accordance with the latest edition of the "National Design Specification for Wood Construction." (NDS) and "Design Specification for Metal Plate Connected Wood Trusses." The truss manufacturer shall provide adequate bracing information in accordance with "Commentary and Recommendations for Handling, Installing, and Bracing Metal Plate Connected Wood Trusses" (HLB-91). This bracing, both temporary and permanent, shall be shown on the shop drawings. Also, the shop drawings shall show the required attachments for the trusses.
- Any chords or truss webs shown on these drawings have been shown as a reference only. The final design of the trusses shall be per the manufacturer.

WOOD STRUCTURAL PANELS:

- Fabrication and placement of structural wood sheathing shall be in accordance with the APA Design/Construction Guide "Residential and Commercial," and all other applicable APA standards.
- All structurally required wood sheathing shall bear the mark of the APA.
- Wood wall sheathing shall comply with the requirements of local building codes for the appropriate state as indicated on these drawings. Refer to wall bracing notes in plan set for more information. Sheathing shall be applied with the long direction perpendicular to framing, unless noted otherwise.
- Roof sheathing shall be APA rated sheathing exposure 1 or 2. Roof sheathing shall be continuous over two supports and attached to its supporting roof framing with (1)-8d CC nail at 6"o/c at panel edges and at 12"o/c in panel field unless otherwise noted on the plans. Sheathing shall be applied with the long direction perpendicular to framing. Sheathing shall have a span rating consistent with the plywood clips or lumber blocking unless otherwise noted. Panel end joints shall occur over framing. Apply building paper over the sheathing as required by the state Building Code.
- Wood floor sheathing shall be APA rated sheathing exposure 1 or 2. Attach sheathing to its supporting framing with (1)-8d CC ringshank nail at 6"o/c at panel edges and at 12"o/c in panel field unless otherwise noted on the plans. Sheathing shall be applied perpendicular to framing. Sheathing shall have a span rating consistent with the framing spacing. Use suitable edge support by use of T&G plywood or lumber blocking unless otherwise noted. Panel end joints shall occur over framing. Apply building paper over the sheathing as required by the state Building Code.
- Sheathing shall have a 1/8" gap at panel ends and edges as recommended in accordance with the APA.

STRUCTURAL FIBERBOARD PANELS:

- Fabrication and placement of structural fiberboard sheathing shall be in accordance with the applicable AFA standards.
- Fiberboard wall sheathing shall comply with the requirements of local building codes for the appropriate state as indicated on these drawings. Refer to wall bracing notes in plan set for more information.
- Sheathing shall have a 1/8" gap at panel ends and edges as recommended in accordance with the AFA.

EXTERIOR WOOD FRAMED DECKS:

- Decks are to be framed in accordance with local building codes and as referenced on the structural plans, either through code references or construction details.

STRUCTURAL STEEL:

- Structural steel shall be fabricated and erected in accordance with the American Institute of Steel Construction "Code of Standard Practice for Steel Buildings and Bridges" and of the manual of Steel Construction "Load Resistance Factor Design" latest editions.
- All steel shall have a minimum yield stress (Fy) of 36 ksi unless otherwise noted.
- Welding shall conform to the latest edition of the American Welding Society's Structural Welding Code AWS D1.1. Electrodes for shop and field welding shall be class E70XX. All welding shall be performed by a certified welder per the above standards.

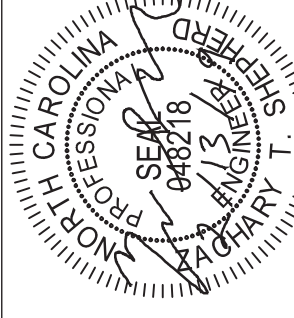

Cane Mill
Lot 14

STRUCTURAL MEMBERS ONLY

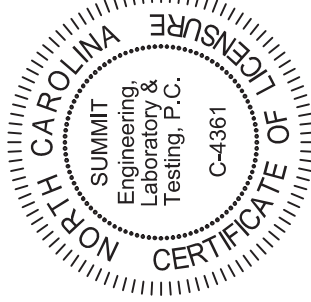

PROJECT
Buttington
Coversheet
CLIENT
Smith Douglas Homes
2520 Reliance Ave.
Apex, NC 27539

CURRENT DRAWING

DATE: 2/13/19

SCALE: 1/8"=1'-0"

PROJECT #: 3832.202R

DRAWN BY: ZTS

CHECKED BY: WAJ

ORIGINAL DRAWING

DATE
12/11/15

PROJECT#
3832.09

REFER TO COVER SHEET FOR A
COMPLETE LIST OF REVISIONS

SHEET

CS2

GENERAL STRUCTURAL NOTES:

- CONSTRUCTION SHALL CONFORM TO 2008 NORTH CAROLINA RESIDENTIAL BUILDING CODE WITH ALL LOCAL AMENDMENTS.
- CONTRACTOR SHALL VERIFY ALL DIMENSIONS. CONTRACTOR SHALL CORRECTLY WITH THE CONTENTS OF THE DRAWING FOR THIS SPECIFIC PROJECT. ENGINEER IS NOT RESPONSIBLE FOR ANY DEVIATIONS FROM THIS PLAN.
- TO RESIST ALL EXCESS UNDESIGNED DURING CONSTRUCTION.
- PROPERTIES USED IN THE DESIGN ARE AS FOLLOWS:
MICROALLOY (LVL) F_y = 50,000 PSI, F_v = 285 PSI, E = 1,900,000 PSI
PARALLEL (FIBER) F_y = 50,000 PSI, F_v = 285 PSI, E = 1,900,000 PSI
PERPENDICULAR (FIBER) F_y = 50,000 PSI, F_v = 285 PSI, E = 1,900,000 PSI
COLUMNS AND JOISTS SHALL BE 9" STP (UNO).
- ALL BEAMS SHALL BE SUPPORTED WITH A (1) 2x4 "9" STP STUD COLUMN AT EACH END UNLESS NOTED OTHERWISE.
- ALL REINFORCING STEEL SHALL BE GRADE 60 BARS CONFORMING TO ASTM A603.
- FOUNDATION AND ANCHORAGE SHALL BE CONSTRUCTED PER THE 2008 NORTH CAROLINA RESIDENTIAL CODE SECTION R402.16. MINIMUM 1/2" DIA. BOLTS SPACED AT 6'-0" ON CENTER WITH A 1" MINIMUM EMBEDMENT INTO MASONRY OR CONCRETE. ANCHOR BOLTS SHALL BE 7" FROM THE END OF EACH PLATE SECTION LOCATED AT THE CENTER THIRD OF THE PLATE.
- CONTRACTOR TO PROVIDE LOOKOUTS WHEN CEILING JOISTS SPAN PERPENDICULAR TO RAFTERS.
- FITCH BEAMS 4x12 LVL'S AND 3x12 LVL'S SIZE LOADED LVL'S SHALL BE BOLTED TO RAFTERS PER DETAIL 1061. ALL JOIST END CONNECTIONS SHALL BE BY EQUIVALENT CONNECTION PER DETAIL 1024. MIN. EDGE DISTANCE SHALL BE 4" AND (1) BOLTS SHALL BE LOCATED MINIMUM 6" FROM EACH END OF THE BEAM.
- ALL NON-LOAD BEARING HEADERS EXCEEDING 8'-0" IN WIDTH AND/OR WITH MORE THAN ONE JOIST ABOVE SHALL BE (1) FLAT 2x4 STP "9" DROPPED. (UNLESS NOTED OTHERWISE).
- ABBREVIATIONS:
S1 = SINGLE JOIST
S2 = DOUBLE JOIST
SC = STUD COLUMN
DR = DOUBLE RAFTER
EE = EACH END
OC = ON CENTER
CL = CENTER LINE

NOTE: DASHED LINE INDICATES JOIST SUPPORTED LOAD BEARING WALL ABOVE. PROVIDE BLOCKING UNDER JOIST SUPPORTED LOAD BEARING WALL.

NOTE: SHADDED WALLS INDICATE LOAD BEARING WALLS.

JOIST & BEAM SIZES SHOWN ARE MINIMUMS. BUILDER THAT INCREASE DEPTH FOR EASE OF CONSTRUCTION.

NOTE: REDUCE JOIST SPACING UNDER TILE FLOORS, GRANITE COUNTERTOPS AND/OR ISLANDS.

THESE PLANS ARE DESIGNED IN ACCORDANCE WITH ARCHITECTURAL PLANS PROVIDED BY SMITH DOUGLAS HOMES. UNLESS OTHERWISE NOTED, ALL DIMENSIONS SHALL BE THE RESPONSIBILITY OF THE CLIENT. CONTRACTOR SHALL VERIFY ALL DIMENSIONS PRIOR TO CONSTRUCTION. SMITH ENGINEERING, LABORATORY & TESTING, P.C. CANNOT GUARANTEE THE ADEQUACY OF THESE STRUCTURAL PLANS WHEN USED WITH ARCHITECTURAL PLANS DATED DIFFERENTLY THAN THE DATE LISTED ABOVE.

STRUCTURAL MEMBERS ONLY
ENGINEERING SEAL APPLIES ONLY TO STRUCTURAL COMPONENTS ON THIS DOCUMENT. SEAL DOES NOT INCLUDE CONSTRUCTION MEANS, METHODS, TECHNIQUES, SEQUENCES, PROCEDURES OR SAFETY PRECAUTIONS. ANY DEVIATIONS OR DISCREPANCIES ON PLANS ARE TO BE BROUGHT TO THE IMMEDIATE ATTENTION OF SMITH ENGINEERING, LABORATORY & TESTING, P.C. FAILURE TO DO SO WILL VOID SUMMIT LIABILITY.

STRUCTURAL ANALYSIS BASED ON 2016 NCR. C.

FIRST FLOOR FRAMING PLAN

SCALE: 1/8"=1'

STUD COLUMN (S.C.) CALLOUTS ON PLAN OVERRIDE JACK STUD COUNT SHOWN IN BEAM/HEADER SCHEDULE. KING STUDS TO BE INSTALLED PER APPLICABLE BUILDING CODE.

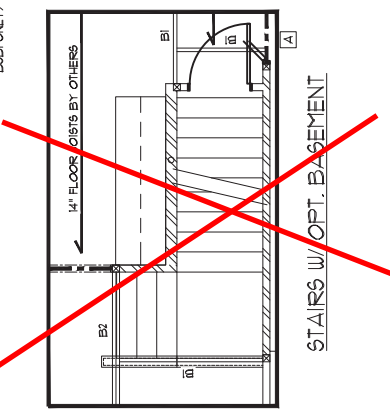
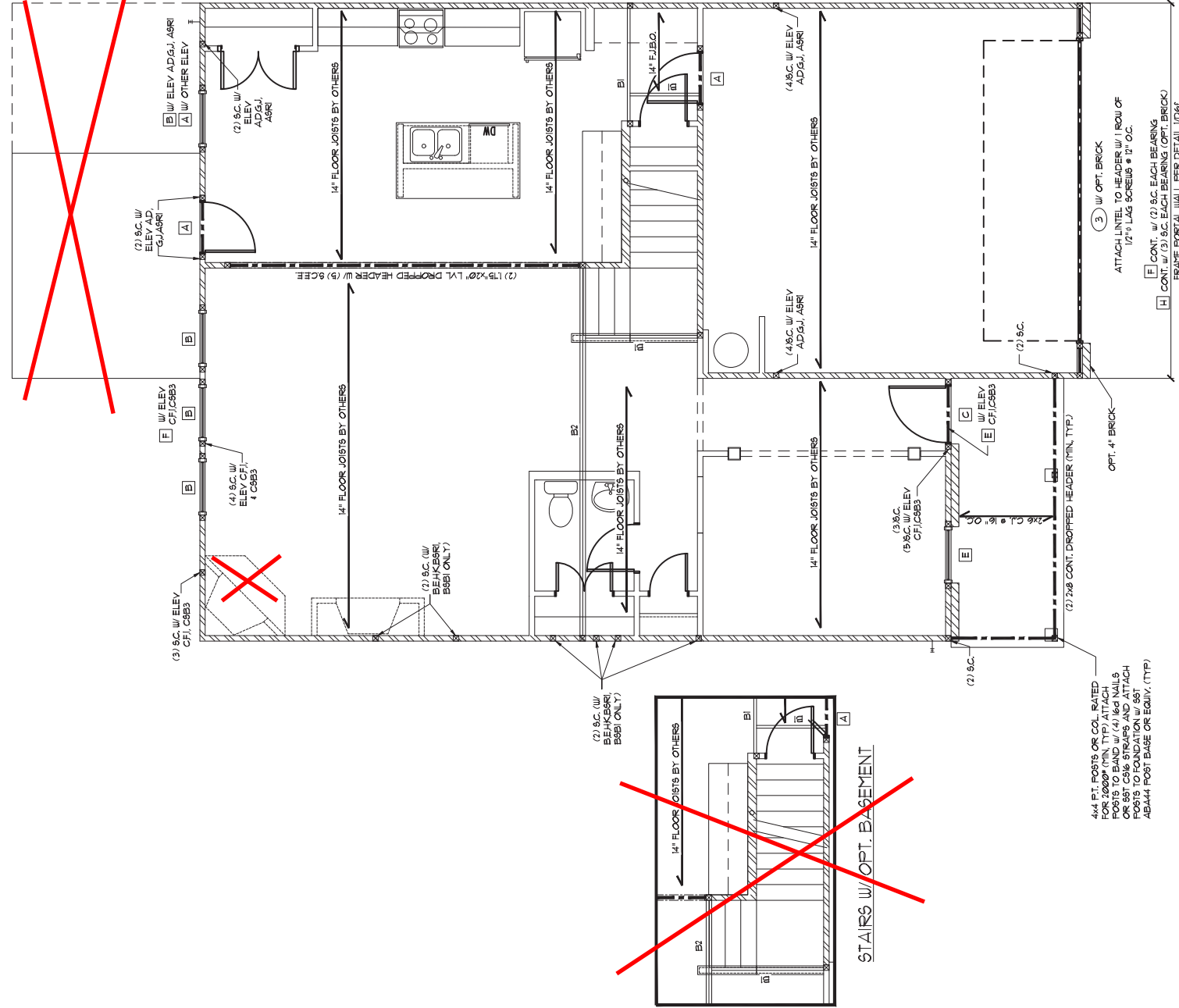

ALL ELEVATIONS

OPT. SIDE ENTRY GARAGE

Cane Mill Lot 14

HEADER/BEAM SCHEDULE

| HEADER TAG | BEAM TAG | SIZE | JACKS (EACH END) |
|------------|----------|----------------------|------------------|
| - | BI | (1) 1/4" FLOOR JOIST | (2) |
| - | B2 | (2) 1/4" FLOOR JOIST | (2) |
| A | B3 | (2) 2x6 | (1) |
| B | B4 | (2) 2x6 | (2) |
| C | B5 | (2) 2x6 | (2) |
| D | B6 | (2) 2x6 | (2) |
| E | B7 | (2) 9x12 LVL | (3) |
| F | B8 | (2) 12x16 LVL | (3) |
| G | B9 | (2) 14" LVL | (3) |
| H | B10 | (2) 16" LVL | (3) |
| I | B11 | (2) 18" LVL | (3) |
| J | B12 | (2) 24" LVL | (4) |
| K | B13 | (3) 9x12 LVL | (3) |
| L | B14 | (3) 12x16 LVL | (3) |
| M | B16 | (3) 14" LVL | (3) |
| N | B17 | (3) 16" LVL | (3) |
| O | B18 | (3) 18" LVL | (3) |
| P | B19 | (3) 24" LVL | (4) |

HEADER/BEAM SIZES SHOWN ON PLANS ARE MINIMUMS. GREATER HEADER/BEAM SIZES MAY BE USED FOR EASE OF CONSTRUCTION. HEADERS TO BE INSTALLED PER DETAIL 1061 UNLESS NOTED OTHERWISE. ALL BEAMS TO BE FLASH UNLESS NOTED OTHERWISE.

LINTEL SCHEDULE

| TAG | SIZE | OPENING SIZE |
|-----|----------------|----------------------------|
| (1) | L3x3x1/4" | LESS THAN 6'-0" TO 10'-0" |
| (2) | L3x3x1/4" | 6'-0" TO 10'-0" |
| (3) | L3x3-1/2"x3/8" | GREATER THAN 10'-0" |
| (4) | L3x3-1/2"x3/8" | ALL ARCHED OPENINGS EQUIV. |

SECURE LINTEL TO HEADER W/ (2) 1/2" DIA. METAL LAG SCREWS STAGGERED @ 16" O.C. (TYP FOR (3)).

ALL HEADERS WITH BRICK ABOVE: (1) (UNO)

WALL STUD SCHEDULE

8x4 AND FLOOR LOAD BEARING STUDS:
2x4 STUDS @ 16" O.C. OR 2x6 STUDS @ 24" O.C.
2x4 STUDS @ 16" O.C. OR 2x6 STUDS @ 24" O.C.
BASEMENT LOAD BEARING STUDS:
2x4 STUDS @ 16" O.C. OR 2x6 STUDS @ 24" O.C.
NON-LOAD BEARING STUDS (WALL BARS):
2x4 STUDS @ 24" O.C.
TWO STORY WALLS:
2x4 STUDS @ 12" O.C. OR 2x6 STUDS @ 16" O.C. BALLOON FRAMED W/ CROSS BRACING @ 6'-0" O.C. VERTICALLY

KING STUD REQUIREMENTS

| OPENING WIDTH | KINGS (EACH END) |
|------------------|------------------|
| LESS THAN 3'-0" | (1) |
| 3'-0" TO 4'-0" | (2) |
| 4'-0" TO 8'-0" | (3) |
| 8'-0" TO 12'-0" | (5) |
| 12'-0" TO 16'-0" | (6) |

KING STUD REQUIREMENTS ABOVE DO NOT APPLY TO PORTAL FRAMED OPENINGS

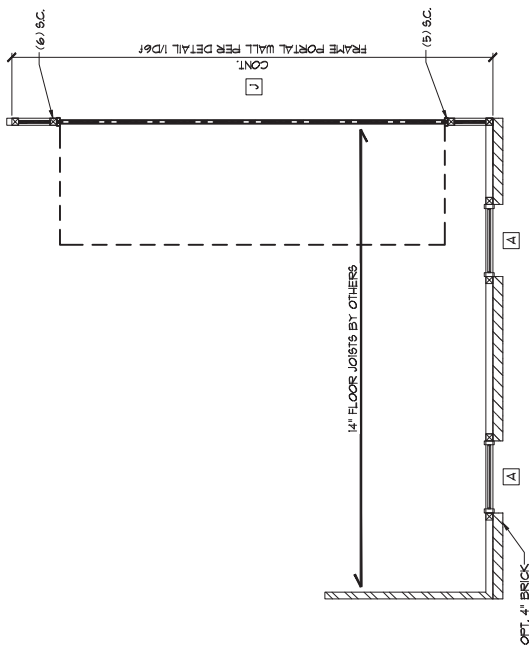

PROJECT
Buttington
Client
Smith Douglas Homes - Raleigh
2520 Reliance Ave.
Apex, NC 27539

CURRENT DRAWING
DATE: 2/13/19
SCALE: 1/8"=1'-0"
PROJECT #: 3832.202R
DRAWN BY: ZTS
CHECKED BY: WAJ

ORIGINAL DRAWING
DATE: 12/11/15
PROJECT#: 3832.09

REFER TO COVER SHEET FOR A COMPLETE LIST OF REVISIONS

SHEET

S3.0

STRUCTURAL MEMBERS ONLY

| HEADER TAG | BEAM TAG | SIZE | JACKS (EACH END) |
|------------|----------|---------------------|------------------|
| - | B1 | (1) 14" FLOOR JOIST | (2) |
| - | B2 | (2) 14" FLOOR JOIST | (2) |
| - | A | (2) 2x6 | (1) |
| - | B4 | (2) 2x6 | (2) |
| - | B5 | (2) 2x6 | (2) |
| - | B6 | (2) 2x6 | (2) |
| - | B7 | (2) 1x12 LVL | (2) |
| - | B8 | (2) 1x12 LVL | (2) |
| - | B9 | (2) 1x12 LVL | (2) |
| - | B10 | (2) 1x12 LVL | (2) |
| - | H | (2) 1x12 LVL | (2) |
| - | J | (2) 2x4 LVL | (4) |
| - | K | (3) 2x4 LVL | (3) |
| - | L | (3) 1x12 LVL | (3) |
| - | M | (3) 1x12 LVL | (3) |
| - | N | (3) 1x12 LVL | (3) |
| - | O | (3) 1x12 LVL | (3) |
| - | P | (3) 2x4 LVL | (4) |

HEADER BEAM SIZES SHOWN ON PLANS ARE MINIMUMS. GREATER HEADER BEAM SIZES MAY BE USED FOR EASE OF CONSTRUCTION. ALL HEADERS TO BE INSTALLED IN ACCORDANCE WITH APPLICABLE BUILDING CODE UNLESS NOTED OTHERWISE. ALL BEAMS TO BE FLASH IN LESS NOTED OTHERWISE.

| TAGS | SIZE | OPENING SIZE |
|------|---------------------|---------------------|
| (1) | L3x3x1/4" | LESS THAN 10'-0" |
| (2) | L3x3x1/4" | 6'-0" TO 10'-0" |
| (3) | L3x3-1/2"x5/8"x1/8" | GREATER THAN 10'-0" |
| (4) | L3x3-1/2"x5/8"x1/8" | ALL ARCHED OPENINGS |

SECURE LINTEL TO HEADER w/ (3) 1/2" DIAMETER LAG SCREWS STAGGERED @ 16" O.C. (1) FOR (2)

ALL HEADERS WITH BRICK ABOVE: (U) NO

| OPENING WIDTH | KINGS (EACH END) |
|------------------|------------------|
| LESS THAN 3'-0" | (1) |
| 3'-0" TO 4'-0" | (2) |
| 4'-0" TO 8'-0" | (3) |
| 8'-0" TO 12'-0" | (5) |
| 12'-0" TO 16'-0" | (6) |

KING STUD REQUIREMENTS ABOVE DO NOT APPLY TO PORTAL FRAMED OPENINGS

| SIZE | OPENING SIZE |
|---------------------|---------------------|
| L3x3x1/4" | LESS THAN 10'-0" |
| L3x3x1/4" | 6'-0" TO 10'-0" |
| L3x3-1/2"x5/8"x1/8" | GREATER THAN 10'-0" |

SECURE LINTEL TO HEADER w/ (3) 1/2" DIAMETER LAG SCREWS STAGGERED @ 16" O.C. (1) FOR (2)

ALL HEADERS WITH BRICK ABOVE: (U) NO

WALL STUD SCHEDULE

1x12 AND 2x6 OSB LOAD BEARING STUDS
 2x4 STUDS @ 16" O.C. OR 2x6 STUDS @ 24" O.C.
 2x4 STUDS @ 16" O.C. OR 2x6 STUDS w/ WALLS w/ ATIG
 2x4 STUDS @ 17" O.C. OR 2x6 STUDS @ 16" O.C.
 EMBASEMENT LOAD BEARING STUDS
 1x12 AND 2x6 STUDS @ 16" O.C.
 NON-LOAD BEARING STUDS (WALL HEADERS)
 2x4 STUDS @ 24" O.C.
 2ND STORY WALLS
 2x4 STUDS @ 17" O.C. OR 2x6 STUDS @ 16" O.C. BALLOON FRAMED w/ CROSS BRACING @ 6'-0" O.C. VERTICALLY

THESE PLANS ARE DESIGNED IN ACCORDANCE WITH ARCHITECTURAL PLANS PROVIDED BY SMITH DOUGLAS HOMES. COMPLETED/REVISED PLANS WILL BE THE RESPONSIBILITY OF THE CLIENT. OWNER'S REPRESENTATIVE WILL BE RESPONSIBLE FOR THE PLANS TO BE MAINTAINED AND MADE TO THE ARCHITECTURAL PLANS PRIOR TO CONSTRUCTION. SMITH ENGINEERING, LABORATORY & TESTING, P.C. CANNOT GUARANTEE THE ADEQUACY OF THESE STRUCTURAL PLANS WHEN USED WITH ARCHITECTURAL PLANS DATED DIFFERENTLY THAN THE DATE LISTED ABOVE.

STRUCTURAL MEMBERS ONLY

ENGINEERING SEAL APPLIES ONLY TO STRUCTURAL COMPONENTS ON THIS DOCUMENT. SEAL DOES NOT INCLUDE CONSTRUCTION MEANS, METHODS, TECHNIQUES, SEQUENCES, PROCEDURES OR SAFETY PRECAUTIONS. ANY DEVIATIONS OR DISCREPANCIES ON PLANS ARE TO BE BROUGHT TO THE IMMEDIATE ATTENTION OF SMITH ENGINEERING, LABORATORY & TESTING, P.C. FAILURE TO DO SO WILL VOID SUMMIT LIABILITY.

STRUCTURAL ANALYSIS BASED ON 2016 NCR.

SECOND FLOOR FRAMING PLAN
 SCALE: 1/8"=1'

STUD COLUMN (S.C.) CALLOUTS ON PLAN OVERRIDE JACK STUD COUNT SHOWN IN BEAM/HEADER SCHEDULE. KING STUDS TO BE INSTALLED PER APPLICABLE BUILDING CODE.

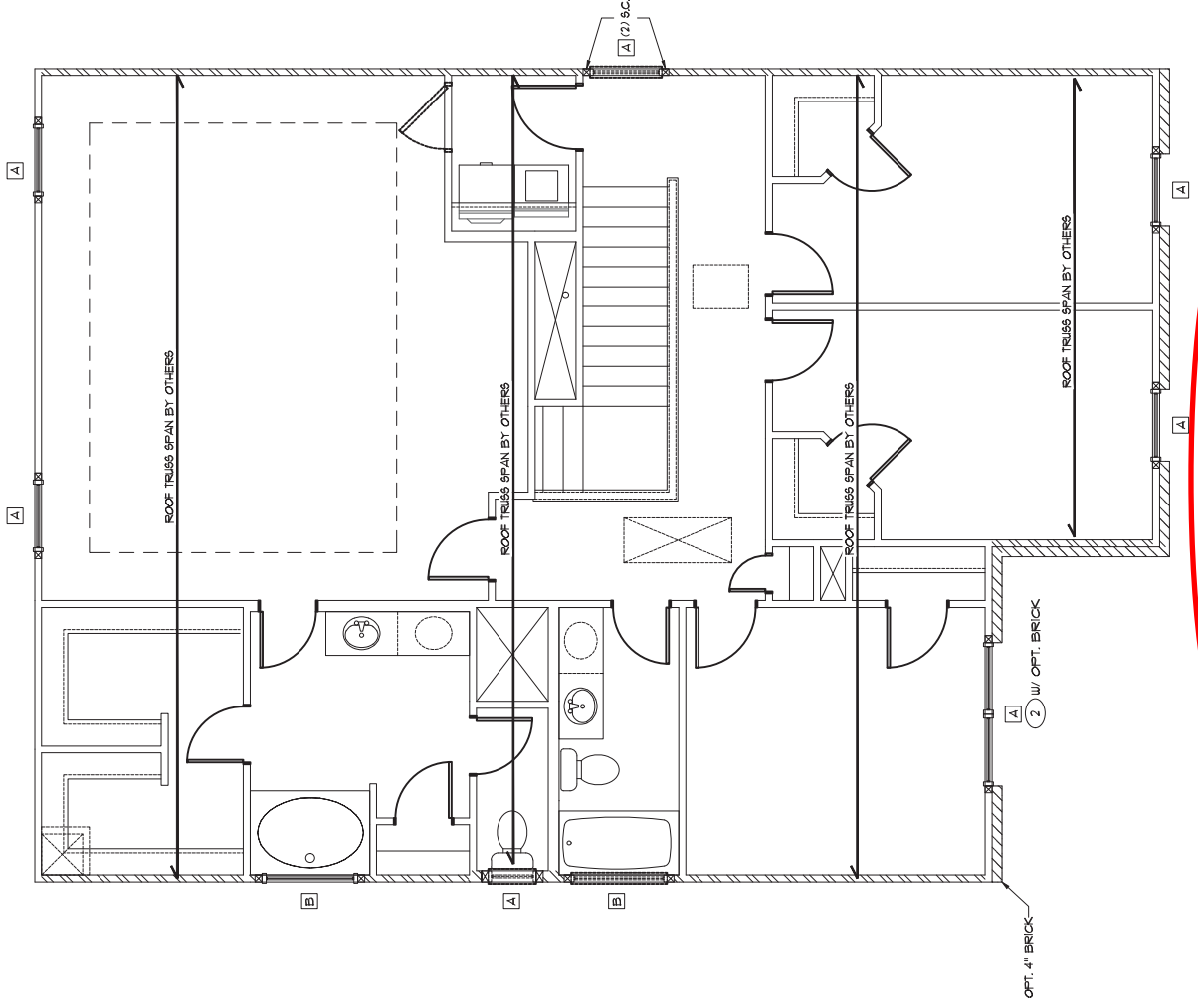

ELEVATIONS BE, HK, BSRI, BSB

OPTIONAL LOFT ILO BEDROOMS 3 & 4

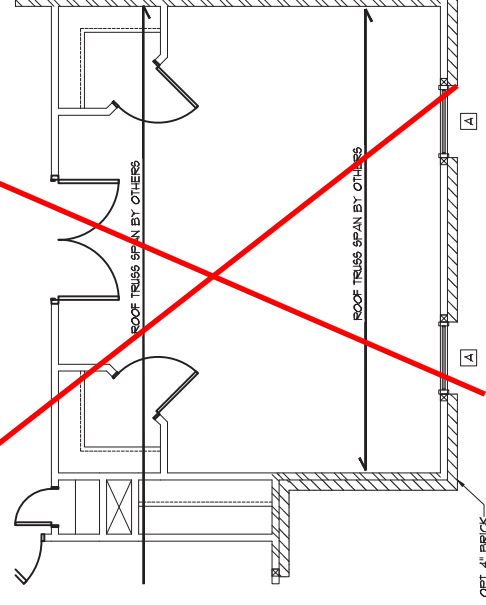

Cane Mill Lot 14

STRUCTURAL MEMBERS ONLY

SUMMIT
 ENGINEERING, LABORATORY TESTING
 3070 HAMMOND BUSINESS PLACE, SUITE 171
 RALEIGH, NC 27603
 OFFICE: 919.380.9991
 FAX: 919.380.9993
 WWW.SUMMIT-COMPANIES.COM

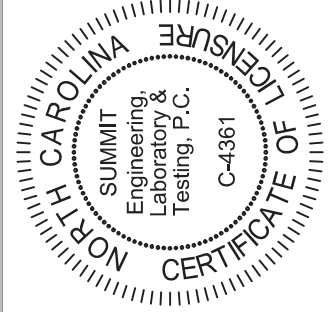

Second Floor Framing Plan
 PROJECT: Buftington
 CLIENT: Smith Douglas Homes - Raleigh
 2520 Reliance Ave.
 Apex, NC 27539

CURRENT DRAWING
 DATE: 2/13/19
 SCALE: 1/8"=1'-0"
 PROJECT #: 3632.202R
 DRAWN BY: ZTS
 CHECKED BY: WAJ

ORIGINAL DRAWING
 DATE: 12/11/15
 PROJECT #: 3832.09

REFER TO COVER SHEET FOR A COMPLETE LIST OF REVISIONS

SHEET
S4.1

| TRUSS UPLIFT CONNECTOR SCHEDULE | |
|---------------------------------|-------------------|
| MODEL * | MAX. UPLIFT (LBS) |
| H1 | 595 |
| H2A | 575 |
| H2BA | 600 |
| H6 | 950 |
| H10A* | 1340 |
| H4* | 1465 |

| MODEL * | MAX. UPLIFT (LBS) | PLY * |
|-------------|-------------------|-------|
| LG1* | 2050 | 2 |
| LG13-SD513* | 3605 | 3 |
| LG14-SD593* | 4060 | 4 |
| HGT-2* | 10990 | 2 |
| HGT-3* | 10530 | 3 |
| HGT-4* | 9250 | 4 |

1. ALL PRODUCTS LISTED ARE SIMPSON STRONG-TIE. ALL PRODUCTS MAY BE USED PER MANUF. SCHEDULE. DOUBLE ANCHORS MAY BE USED FOR A SINGLE ANCHOR. DOUBLE ANCHORS MAY BE USED TO DOUBLE THE UPLIFT CAPACITIES SHOWN ABOVE. PROVIDED A MINIMUM 2-1/2" MEMBER THICKNESS. ITEMS DENOTED WITH "*" MAY NOT BE DOUBLED TO INCREASE UPLIFT CAPACITIES. CAPACITIES MAY VARY. ITEMS SHOWN ABOVE ARE FOR SYP #2 GRADE OR BETTER MEMBERS. PLEASE CONTACT EOR OR TRUSS MANUF. IF SPECIES OR GRADE VARIES. 2. THE UPLIFT CAPACITY OF THIS CONNECTION IS BASED ON THE TRUSS MANUF. EOR IS NOT RESPONSIBLE FOR THESE CONNECTIONS.

NOTE: 1ST PLY OF ALL SHOWN GIRDER TRUSSES TO ALIGN WITH INSIDE FACE OF WALL (TYP. UNO)

NOTE: ROOF TRUSSES SHALL BE SPACED TO SUPPORT FALSE FRAMED CORNER WALLS (TYP. UNO)

THESE PLANS ARE DESIGNED IN ACCORDANCE WITH ARCHITECTURAL PLANS. THE CLIENT IS RESPONSIBLE FOR VERIFYING ALL DIMENSIONS AND CONDITIONS PRIOR TO CONSTRUCTION. ANY CHANGES MADE TO THE ARCHITECTURAL PLANS PRIOR TO CONSTRUCTION SHALL BE THE RESPONSIBILITY OF THE CLIENT TO NOTIFY SUMMIT ENGINEERING LABORATORY & TESTING, P.C. IF ANY CHANGES ARE MADE TO THE ARCHITECTURAL PLANS PRIOR TO CONSTRUCTION. SUMMIT ENGINEERING LABORATORY & TESTING, P.C. CANNOT BE HELD RESPONSIBLE FOR ANY CHANGES MADE TO THE ARCHITECTURAL PLANS DATED DIFFERENTLY THAN THE DATE LISTED ABOVE.

REFER TO TRUSS LAYOUT PER MANUFACTURER FOR UPLIFT CONNECTIONS FROM TRUSS TO TOP PLATE (TYP. UNO)

NOTE: TRUSS UPLIFT LOADS SHALL BE DETERMINED PER TRUSS MANUFACTURER IN ACCORDANCE WITH SECTION R602.J11.1 WALL SHEATHING AND FASTENERS HAVE BEEN DESIGNED TO RESIST THE UPLIFT LOAD PATH IN ACCORDANCE WITH METHOD 3 OF SECTION R602.J11.1. REFER TO MANUFACTURER'S SPECIFIED WALL PLANS FOR SHEATHING AND FASTENER REQUIREMENTS.

STRUCTURAL MEMBERS ONLY
 ENGINEERING SEAL APPLIES ONLY TO STRUCTURAL COMPONENTS ON THIS DOCUMENT. SEAL DOES NOT INCLUDE CONSTRUCTION MEANS, METHODS, TECHNIQUES, SEQUENCES, PROCEDURES OR SAFETY PRECAUTIONS. ANY DEVIATIONS OR DISCREPANCIES ON PLANS ARE TO BE BROUGHT TO THE IMMEDIATE ATTENTION OF SUMMIT ENGINEERING, LABORATORY & TESTING, P.C. FAILURE TO DO SO WILL VOID SUMMIT LIABILITY.
 STRUCTURAL ANALYSIS BASED ON 2016 NCR.

ROOF FRAMING PLAN
 SCALE: 1/8"=1'



ELEVATIONS BEHK, BSRI, & BSB1

ROOF BELOW SUPPORTS BY OTHERS

ROOF TRUSS SPAN BY OTHERS

ROOF TRUSS SPAN BY OTHERS

ROOF TRUSS SPAN BY OTHERS

ROOF TRUSS SPAN BY OTHERS

ROOF TRUSS SPAN BY OTHERS

ROOF TRUSS SPAN BY OTHERS

ROOF TRUSS SPAN BY OTHERS

ROOF TRUSS SPAN BY OTHERS

ROOF TRUSS SPAN BY OTHERS

ROOF TRUSS SPAN BY OTHERS

ROOF TRUSS SPAN BY OTHERS

ROOF TRUSS SPAN BY OTHERS

ROOF TRUSS SPAN BY OTHERS

ROOF TRUSS SPAN BY OTHERS

ROOF TRUSS SPAN BY OTHERS

ROOF TRUSS SPAN BY OTHERS

ROOF TRUSS SPAN BY OTHERS

ROOF TRUSS SPAN BY OTHERS



PROJECT
 Buftington
 CLIENT
 Smith Douglas Homes - Raleigh
 2520 Reliance Ave.
 Apex, NC 27539

CURRENT DRAWING
 DATE: 2/13/19
 SCALE: 1/8"=1'-0"
 PROJECT #: 3632.202R
 DRAWN BY: ZTS
 CHECKED BY: WAJ

ORIGINAL DRAWING
 DATE: 12/11/15
 PROJECT#: 3832.09

REFER TO COVER SHEET FOR A COMPLETE LIST OF REVISIONS

SHEET
S5.1

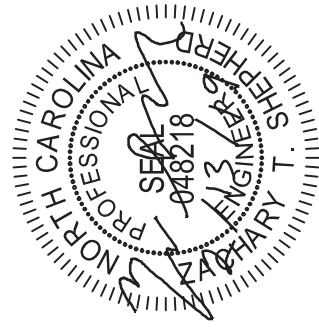

STRUCTURAL MEMBERS ONLY

Cane Mill Lot 14

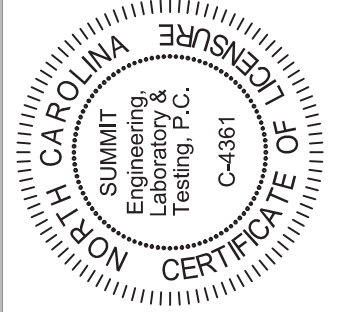

PROJECT
Buttington
Client
First Floor Bracing
Smith Douglas Homes - Raleigh
2520 Reliance Ave.
Apex, NC 27539

CURRENT DRAWING
DATE: 2/13/19
SCALE: 1/8" = 1'-0"
PROJECT #: 3632.202R
DRAWN BY: ZTS
CHECKED BY: WAJ

ORIGINAL DRAWING
DATE: 12/11/15
PROJECT#: 3832.09

REFER TO COVER SHEET FOR A COMPLETE LIST OF REVISIONS

SHEET
S7.0

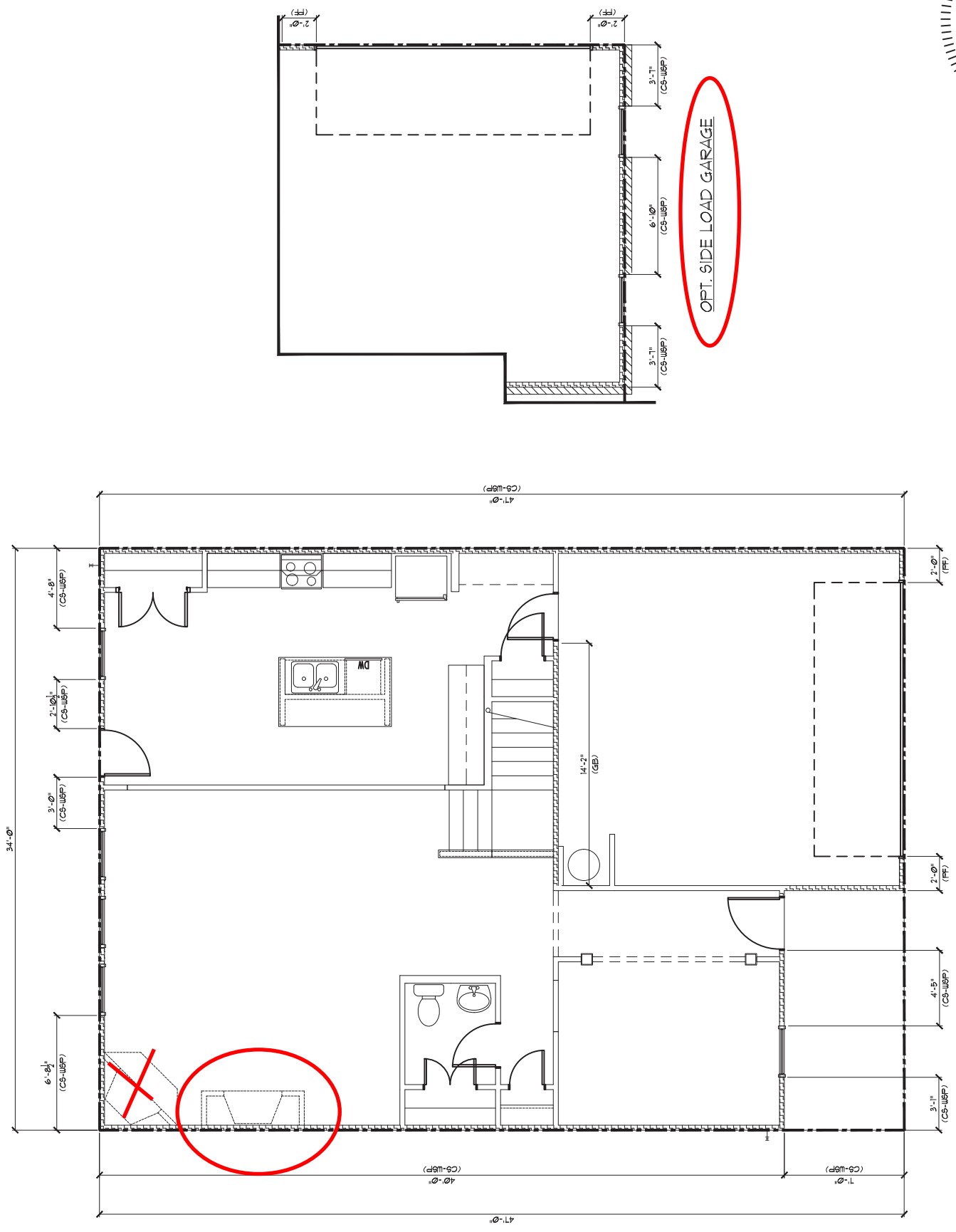

ALL ELEVATIONS

Cane Mill
Lot 14



STRUCTURAL MEMBERS ONLY

REQUIRED BRACED WALL PANEL CONNECTIONS

| METHOD | MATERIAL | MIN. THICKNESS | REQUIRED CONNECTION |
|--------|-----------------------|----------------|---|
| CS-U8P | WOOD STRUCTURAL PANEL | 3/8" | INTERMEDIATE SUPPORTS 6d COMMON NAILS @ 12" O.C. |
| GB | GYPSUM BOARD | 1/2" | 5d COOLER NAILS @ 1" O.C. |
| U8P | STRUCTURAL PANEL | 3/8" | 6d COMMON NAILS @ 12" O.C. |
| FF | WOOD PANEL | 1/16" | PER FIGURE R602.10.1 |

**OR EQUIVALENT PER TABLE R702.3.5

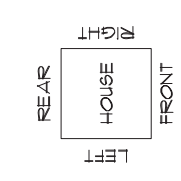

- BRACED WALL NOTES:**
- WALLS SHALL BE DESIGNED IN ACCORDANCE WITH SECTION R602.10 FROM THE 2018 NORTH CAROLINA RESIDENTIAL CODE.
 - WALLS ARE DESIGNED FOR SEISMIC ZONES A-C AND ULTIMATE WIND SPEEDS UP TO 130 MPH.
 - ALL BRACED WALL PANELS SHALL BE FULL WALL HEIGHT AND SHALL NOT EXCEED 10 FEET FOR ISOLATED PANEL METHOD AND 12 FEET FOR CONTINUOUS SHEATHING METHOD WITHOUT ADDITIONAL ENGINEERING CALCULATIONS.
 - MINIMUM PANEL LENGTH SHALL BE PER TABLE R602.10.1.
 - THE INTERIOR SIDE OF EXTERIOR WALLS AND BOTH SIDES OF INTERIOR WALLS SHALL BE SHEATHED CONTINUOUSLY WITH MINIMUM 1/2" GYPSUM BOARD.
 - FOR CONTINUOUS SHEATHING METHOD, EXTERIOR WALLS SHALL BE SHEATHED ON ALL SHEATHABLE SURFACES INCLUDING NECK AREAS BETWEEN BRACED WALL PANELS, ABOVE AND BELOW WALL OPENINGS, AND ON GABLE END WALLS.
 - ALL BRACED WALLS SHALL BE BUILT TO BE MORE THAN 24" BEYOND THE FOUNDATION OR BRACING WALL BELOW WITHOUT ADDITIONAL ENGINEERING CALCULATIONS.
 - A BRACED WALL PANEL SHALL BE LOCATED WITHIN 12 FEET OF EACH END OF A BRACED WALL LINE.
 - MASONRY OR CONCRETE STEM WALLS WITH A LENGTH OF 48" OR LESS SUPPORTING A BRACED WALL PANEL SHALL BE DESIGNED IN ACCORDANCE WITH FIGURE R602.10.4.3 OF THE 2018 NRC.
 - CONCRETE OR MASONRY WALLS SUPPORTING A BRACED WALL PANEL SHALL BE CONSTRUCTED IN ACCORDANCE WITH SECTION R602.10.4.
 - BRACED WALL PANEL CONNECTIONS TO ROOF SHALL BE CONSTRUCTED IN ACCORDANCE WITH SECTION R602.10.4.5.
 - CEILING WALLS AND WALK OUT BASEMENT WALLS SHALL BE CONSTRUCTED IN ACCORDANCE WITH SECTION R602.10.4.5.
 - PORTAL WALLS SHALL BE DESIGNED IN ACCORDANCE WITH FIGURE R602.10.1 (NO).
 - ON SCHEMATIC, SHADED WALLS INDICATE BRACED WALL PANELS.
 - ABBREVIATIONS:
GB = GYPSUM BOARD
CS-XXX = CONT. SHEATHED
FF = PORTAL FRAME
U8P = WOOD STRUCTURAL PANEL
ENG = ENGINEERED SOLUTION
FF-ENG = ENG. PORTAL FRAME

THESE PLANS ARE DESIGNED IN ACCORDANCE WITH ARCHITECTURAL PLANS PROVIDED BY SMITH DOUGLAS HOMES COMPLETED/REVISED ON 5/11/19. IT IS THE RESPONSIBILITY OF THE CLIENT TO NOTIFY SUMMIT ENGINEERING LABORATORY TESTING, P.C. IF ANY CHANGES ARE MADE TO THE ARCHITECTURAL PLANS. SMITH DOUGLAS HOMES, SMITH ENGINEERING LABORATORY & TESTING, P.C. CANNOT GUARANTEE THE ADEQUACY OF THESE STRUCTURAL PLANS WHEN USED WITH ARCHITECTURAL PLANS DATED DIFFERENTLY THAN THE DATE LISTED ABOVE.

INSTALL HOLD-DOWNS PER SECTION R602.10.4 AND FIGURE R602.10.4.1 OF THE 2018 NRC.

FIRST FLOOR BRACING (FT)

| CONTINUOUS SHEATHING METHOD | | |
|-----------------------------|----------|-----|
| REQUIRED | PROVIDED | |
| FRONT SIDE | 148 | 206 |
| LEFT SIDE | 11 | 410 |
| REAR SIDE | 148 | 172 |
| RIGHT SIDE | 11 | 410 |

FIRST FLOOR BRACING - SIDE LOAD GARAGE (FT)

| CONTINUOUS SHEATHING METHOD | | |
|-----------------------------|----------|-----|
| REQUIRED | PROVIDED | |
| FRONT SIDE | 148 | 215 |
| LEFT SIDE | 11 | 410 |
| REAR SIDE | 148 | 172 |
| RIGHT SIDE | 11 | 330 |

STRUCTURAL MEMBERS ONLY
ENGINEERING SEAL APPLIES ONLY TO STRUCTURAL COMPONENTS ON THIS DOCUMENT. SEAL DOES NOT INCLUDE CONSTRUCTION MEANS, METHODS, TECHNIQUES, SEQUENCES, PROCEDURES OR SAFETY PRECAUTIONS. ANY DEVIATIONS OR DISCREPANCIES ON PLANS ARE TO BE BROUGHT TO THE IMMEDIATE ATTENTION OF SUMMIT ENGINEERING, LABORATORY & TESTING, P.C. FAILURE TO DO SO WILL VOID SUMMIT LIABILITY.
STRUCTURAL ANALYSIS BASED ON 2018 NRC.

FIRST FLOOR BRACING PLAN
SCALE: 1/8" = 1'



PROJECT
Buftington
CLIENT
Smith Douglas Homes - Raleigh
2520 Reliance Ave.
Apex, NC 27539

CURRENT DRAWING
DATE: 2/13/19
SCALE: 1/8" = 1'-0"
PROJECT #: 3632.202R
DRAWN BY: ZTS
CHECKED BY: WAJ

ORIGINAL DRAWING
DATE: 12/11/15
PROJECT#: 3832.09

REFER TO COVER SHEET FOR A COMPLETE LIST OF REVISIONS

SHEET
S8.0



Cane Mill
Lot 14

STRUCTURAL MEMBERS ONLY

REQUIRED BRACED WALL PANEL CONNECTIONS

| METHOD | MATERIAL | MIN. THICKNESS | REQUIRED CONNECTION |
|--------|-----------------------|----------------|---|
| CS-WBP | WOOD STRUCTURAL PANEL | 3/8" | INTERMEDIATE SUPPORTS 6d COMMON NAILS @ 12" O.C. |
| GB | GYP/UM BOARD | 1/2" | 5d COOLER NAILS @ 1" O.C. |
| WBP | WOOD PANEL | 3/8" | 6d COMMON NAILS @ 12" O.C. |
| FF | WOOD PANEL | 1/16" | PER FIGURE R602.10.1 |

**OR EQUIVALENT PER TABLE R702.3.5

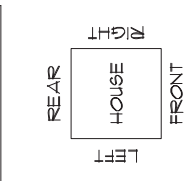

- BRACED WALL NOTES:**
- WALLS SHALL BE DESIGNED IN ACCORDANCE WITH SECTION R602.10 FROM THE 2018 NORTH CAROLINA RESIDENTIAL CODE.
 - WALLS ARE DESIGNED FOR SEISMIC ZONES A-C AND ULTIMATE WIND SPEEDS UP TO 130 MPH.
 - ALL BRACED WALL PANELS SHALL BE FULL WALL HEIGHT AND SHALL NOT EXCEED 10 FEET FOR ISOLATED PANEL METHOD AND 12 FEET FOR CONTINUOUS SHEATHING METHOD WITHOUT ADDITIONAL ENGINEERING CALCULATIONS.
 - MINIMUM PANEL LENGTH SHALL BE PER TABLE R602.10.1.
 - THE INTERIOR SIDE OF EXTERIOR WALLS AND BOTH SIDES OF INTERIOR WALLS SHALL BE SHEATHED CONTINUOUSLY WITH MFRP/1/2" GYPSUM BOARD.
 - FOR CONTINUOUS SHEATHING METHOD, EXTERIOR WALLS SHALL BE SHEATHED ON ALL SHEATHABLE SURFACES INCLUDING NELL AREAS BETWEEN BRACED WALL PANELS, ABOVE AND BELOW WALL OPENINGS, AND ON GABLE END WALLS.
 - ALL BRACED WALLS SHALL BE BUILT TO BE MORE THAN 24" BEYOND THE FOUNDATION OR BEARING WALL BELOW WITHOUT ADDITIONAL ENGINEERING CALCULATIONS.
 - A BRACED WALL PANEL SHALL BE LOCATED WITHIN 12 FEET OF EACH END OF A BRACED WALL LINE.
 - THE DISTANCE BETWEEN BRACED WALL PANELS SHALL NOT EXCEED 21 FEET.
 - MASONRY OR CONCRETE STEM WALLS WITH A LENGTH OF 48" OR LESS SUPPORTING A BRACED WALL PANEL SHALL BE DESIGNED IN ACCORDANCE WITH FIGURE R602.10.4.3 OF THE 2018 NRC.
 - CONCRETE OR MASONRY WALLS SUPPORTING A BRACED WALL PANEL SHALL BE CONSTRUCTED IN ACCORDANCE WITH SECTION R602.10.4.
 - BRACED WALL PANEL CONNECTIONS TO ROOF SHALL BE CONSTRUCTED IN ACCORDANCE WITH SECTION R602.10.4.5.
 - CEILING WALLS AND WALK OUT BASEMENT WALLS SHALL BE CONSTRUCTED IN ACCORDANCE WITH SECTION R602.10.4.5.
 - PORTAL WALLS SHALL BE DESIGNED IN ACCORDANCE WITH FIGURE R602.10.1 (IND).
 - ON SCHEMATIC, SHADED WALLS INDICATE BRACED WALL PANELS.
 - ABBREVIATIONS:
GB = GYPSUM BOARD
CS-WBP = WOOD STRUCTURAL PANEL
CS-XXX = CONT. SHEATHED ENG. ENGINEERED SOLUTION
FF = PORTAL FRAME

THESE PLANS ARE DESIGNED IN ACCORDANCE WITH ARCHITECTURAL PLANS PROVIDED BY SMITH DOUGLAS HOMES. NOTES COMPLETED/REVISED ON 5/10/19. IT IS THE RESPONSIBILITY OF THE CLIENT TO NOTIFY SUMMIT ENGINEERING LABORATORY TESTING, P.C. IF ANY CHANGES ARE MADE TO THE ARCHITECTURAL PLANS. SMITH DOUGLAS HOMES, SMITH ENGINEERING LABORATORY TESTING, P.C. CANNOT GUARANTEE THE ADEQUACY OF THESE STRUCTURAL PLANS WHEN USED WITH ARCHITECTURAL PLANS DATED DIFFERENTLY THAN THE DATE LISTED ABOVE.

SECOND FLOOR BRACING (FT)

| CONTINUOUS SHEATHING METHOD | | |
|-----------------------------|----------|------|
| REQUIRED | PROVIDED | |
| FRONT SIDE | 6.3 | 21.0 |
| LEFT SIDE | 5.1 | 36.5 |
| REAR SIDE | 6.3 | 26.0 |
| RIGHT SIDE | 5.1 | 44.0 |

INSTALL HOLD-DOWNS PER SECTION R602.10.4 AND FIGURE R602.10.4.1 OF THE 2018 NRC.

STRUCTURAL MEMBERS ONLY
ENGINEERING SEAL APPLIES ONLY TO STRUCTURAL COMPONENTS ON THIS DOCUMENT. SEAL DOES NOT INCLUDE CONSTRUCTION MEANS, METHODS, TECHNIQUES, SEQUENCES, PROCEDURES OR SAFETY PRECAUTIONS. ANY DEVIATIONS OR DISCREPANCIES ON PLANS ARE TO BE BROUGHT TO THE IMMEDIATE ATTENTION OF SUMMIT ENGINEERING, LABORATORY & TESTING, P.C. FAILURE TO DO SO WILL VOID SUMMIT LIABILITY.
STRUCTURAL ANALYSIS BASED ON 2018 NRC.

SECOND FLOOR BRACING PLAN
SCALE: 1/8" = 1'

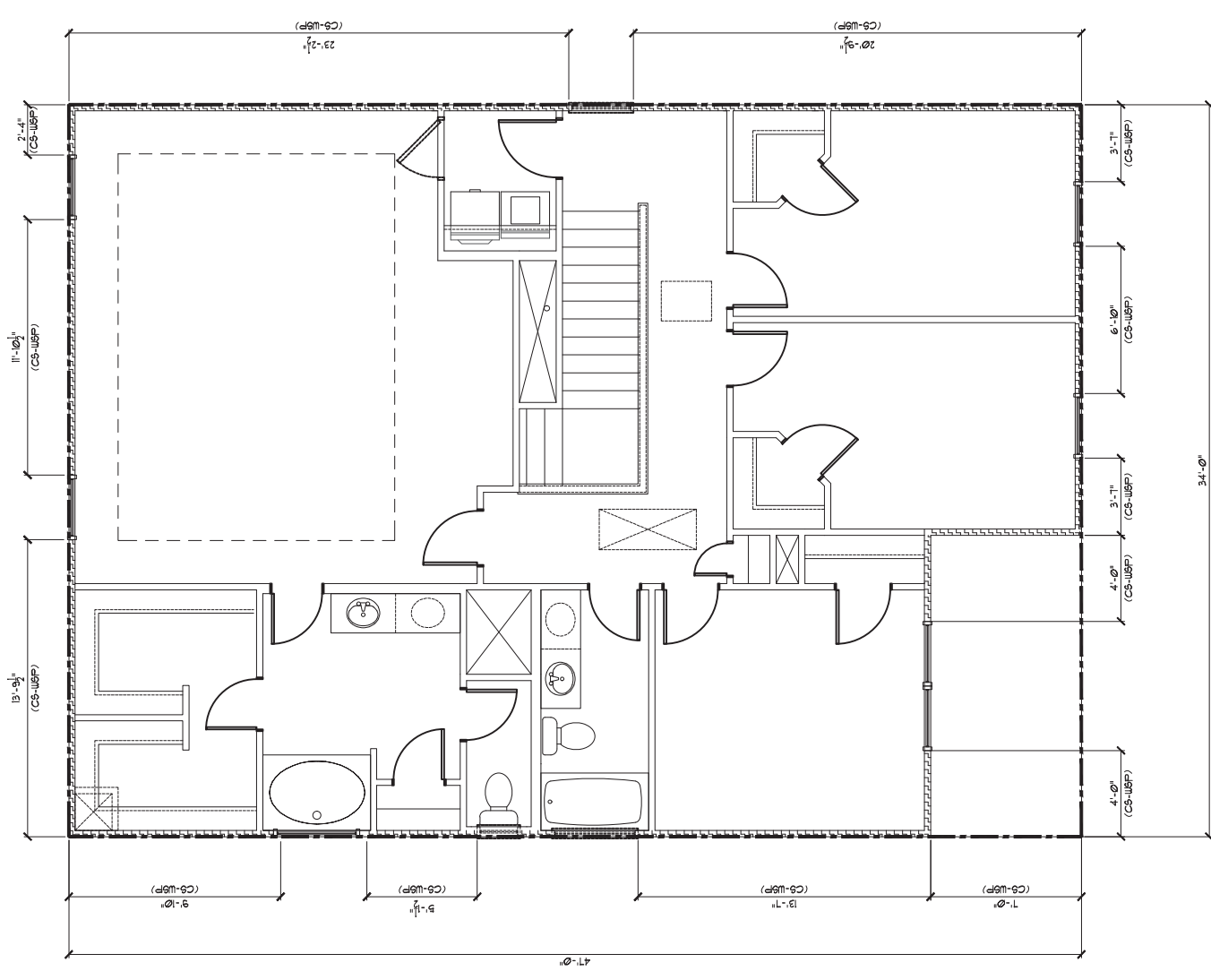

ALL ELEVATIONS

GENERAL STRUCTURAL NOTES:

- The design professional whose seal appears on these drawings is the structural engineer of record (SER) for this project. The SER bears the responsibility of the primary structural elements and the performance of this structure. No other party may revise, alter, or delete any structural aspects of these construction documents without written permission of SUMMIT Engineering, Laboratory & Testing, P.C. (SUMMIT) or the SER. For the purposes of these construction documents the SER and SUMMIT shall be considered the same entity.
- The structure is only stable in its completed form. The contractor shall provide all required temporary bracing during construction to stabilize the structure.
- The SER is not responsible for construction sequences, methods, or techniques in connection with the construction of this structure. The SER will not be held responsible for the contractor's failure to conform to the contract documents, should any non-conformities occur.
- Any structural elements or details not fully developed on the construction drawings shall be completed under the direction of a licensed professional engineer. These shop drawings shall be submitted to SUMMIT for review before any construction begins. The shop drawings will be reviewed for overall compliance as it relates to the structural design of this project. Verification of the shop drawings for dimensions, or for actual field conditions, is not the responsibility of the SER or SUMMIT.
- Verification of assumed field conditions is not the responsibility of the SER. The contractor shall verify the field conditions for accuracy and report any discrepancies to SUMMIT before construction begins.
- The SER is not responsible for any secondary structural elements or non-structural elements, except for the elements specifically noted on the structural drawings.
- This structure and all construction shall conform to all applicable sections of the international residential code.
- This structure and all construction shall conform to all applicable sections of the 2018 North Carolina Residential Code (NCRC) and any local codes or restrictions

FOUNDATIONS:

- Foundations shall be constructed in accordance with chapter 4 of the 2018 NC Residential Building Code (Special consideration shall be given to Chapter 45 in wind zones above 130mph)
- Footing sizes based on a presumptive soil bearing capacity of 2000 PSF. Contractor is solely responsible for verifying the suitability of the site soil conditions at the time of construction
- Maximum depth of unbalanced fill against masonry walls to be as specified in section R404.1 of the 2018 NCRC
- The structural engineer has not performed a subsurface investigation. Verification of this assumed value is the responsibility of the owner or the contractor. Should any adverse soil condition be encountered the SER must be contacted before proceeding.
- The bottom of all footings shall extend below the frost line for the region in which the structure is to be constructed. However, the bottom of all footings shall be a minimum of 12" below grade.
- Any fill shall be placed under the direction or recommendation of a licensed professional engineer. The resulting soil shall be compacted to a minimum of 95% maximum dry density.
- Excavations of footings shall be lined temporarily with a 6 mil polyethylene membrane if placement of concrete does not occur within 24 hours of excavation.
- No concrete shall be placed against any subgrade containing water, ice, frost, or loose material.
- Each crawl space pier shall bear in the middle third of its respective footing and each girder shall bearing in the middle third of the piers. Pilasters to be bonded to perimeter foundation wall
- Crawl spaced to be graded level and clear of all debris
- Provide foundation waterproofing and drain with positive slope to outlet as required by site conditions
- Energy efficiency compliance and insulation of the structure to be in accordance with chapter 11 of the 2018 NCRC

CONCRETE:

- Concrete shall have a normal weight aggregate and a minimum compressive strength (f'c) at 28 days of 3000 psi, unless otherwise noted on the plan.
- Concrete shall be proportioned, mixed, and placed in accordance with the latest editions of ACI 318: "Building Code Requirements for Reinforced Concrete" and ACI 301: "Specifications for Structural Concrete for Buildings".
- Air entrained concrete must be used for all structural elements exposed to freeze/thaw cycles and deicing chemicals. Air entrainment amounts (in percent) shall be within -1% to +2% of target values as follows:
 - Footings: 5%
 - Exterior Slabs: 5%
- No admixtures shall be added to any structural concrete without written permission of the SER
- Concrete slabs-on-grade shall be constructed in accordance with ACI 302.1R-96: "Guide for Concrete Slab and Slab Construction".
- The concrete slab-on-grade has been designed using a subgrade modulus of k=250 pci and a design loading of 200 psf. The SER is not responsible for differential settlement, slab cracking or other future defects resulting from unreported conditions not in accordance with the above assumptions.
- Control or saw cut joints shall be spaced in interior slabs-on-grade at a maximum of 15'-0" O.C. and in exterior slabs-on-grade at a maximum of 10'-0" unless otherwise noted.
- Control or saw cut joints shall be produced using conventional process within 4 to 12 hours after the slab has been finished
- Reinforcing steel may not extend through a control joint. Reinforcing steel may extend through a saw cut joint.
- All welded wire fabric (W.W.F.) for concrete slabs-on-grade shall be placed at mid-depth of slab. The W.W.F. shall be securely supported during the concrete pour. Fibermesh may be used in lieu of W.W.F.

CONCRETE REINFORCEMENT:

- Fibrous concrete reinforcement, or fibermesh, specified in concrete slabs-on-grade may be used for control of cracking due to shrinkage and thermal expansion/contraction, lowered water migration, an increase in impact capacity, increased abrasion resistance, and residual strength.
- Fibermesh reinforcing to be 100% virgin polypropylene fibers containing no reprocessed olefin materials and specifically manufactured for use as concrete secondary reinforcement.
- Application of fibermesh per cubic yard of concrete shall equal a minimum of 0.1% by volume (1.5 pounds per cubic yard)
- Fibermesh shall comply with ASTM C1116, any local building code requirements, and shall meet or exceed the current industry standard.
- Steel Reinforcing bars shall be new billet steel conforming to ASTM A615, grade 60.
- Detailing, fabrication, and placement of reinforcing steel shall be in accordance with the latest edition of ACI 315: "Manual of Standard Practice for Detailing Concrete Structures"
- Horizontal footing and wall reinforcement shall be continuous and shall have 90° bends, or corner bars with the same size/spacing as the horizontal reinforcement with a class B tension splice.
- Lap reinforcement as required, a minimum of 40 bar diameters for tension or compression unless otherwise noted. Splices in masonry shall be a minimum of 48 bar diameters.
- Where reinforcing dowels are required, they shall be equivalent in size and spacing to the vertical reinforcement. The dowel shall extend 48 bar diameters vertically and 20 bar diameters into the footing.
- Where reinforcing steel is required vertically, dowels shall be provided unless otherwise noted.

WOOD FRAMING:

- Solid sawn wood framing members shall conform to the specifications listed in the latest edition of the "National Design Specification for Wood Construction" (NDS). Unless otherwise noted, all wood framing members are designed to be Spruce-Pine-Fir (SPF) #2.
- LVL or PSL engineered wood shall have the following minimum design values:
 - E = 1,900,000 psi
 - Fb = 2600 psi
 - Fv = 285 psi
 - Fc = 700 psi
- Wood in contact with concrete, masonry, or earth shall be pressure treated in accordance with AWPA standard C-15. All other moisture exposed wood shall be treated in accordance with AWPA standard C-2
- Nails shall be common wire nails unless otherwise noted.
- Lag screws shall conform to ANSI/ASME standard B18.2.1-1981. Lead holes for lag screws shall be in accordance with NDS specifications.
- All beams shall have full bearing on supporting framing members unless otherwise noted.
- Exterior and load bearing stud walls are to be 2x4 SPF#2 @16" O.C. unless otherwise noted. Studs shall be continuous from the sole plate to the double top plate. Studs shall only be discontinuous at headers for window/door openings. A minimum of one king stud shall be placed at each end of the header. King studs shall be continuous.
- Individual studs forming a column shall be attached with one 10d nail @6" O.C. staggered. The stud column shall be continuous to the foundation or beam. The column shall be fully blocked at all floor levels to ensure proper load transfer.
- Multi-ply beams shall have each ply attached with (3)10d nails @ 24" O.C.
- Fitch beams and four and five ply beams shall be bolted together with (2) rows of 1/2" dia. through bolts staggered @24" O.C. w/ 2" edge distance and (2) bolts located at 6" from each end, unless noted otherwise.

WOOD TRUSSES:

- The wood truss manufacturer/fabricator is responsible for the design of the wood trusses. Submit sealed shop drawings and supporting calculations to the SER for review prior to fabrication. The SER shall have a minimum of five (5) days for review. The review by the SER shall review for overall compliance with the design documents. The SER shall assume no responsibility for the correctness for the structural design for the wood trusses.
- The wood trusses shall be designed for all required loadings as specified in the local building code, the ASCE Standard "Minimum Design Loads for Buildings and Other Structures." (ASCE 7-10), and the loading requirements shown on these specifications. The truss drawings shall be coordinated with all other construction documents and provisions provided for loads shown on these drawings including but not limited to HVAC equipment, piping, and architectural fixtures attached to the trusses.
- The trusses shall be designed, fabricated, and erected in accordance with the latest edition of the "National Design Specification for Wood Construction." (NDS) and "Design Specification for Metal Plate Connected Wood Trusses."
- The truss manufacturer shall provide adequate bracing information in accordance with "Commentary and Recommendations for Handling, Installing, and Bracing Metal Plate Connected Wood Trusses" (HIB-91). This bracing, both temporary and permanent, shall be shown on the shop drawings. Also, the shop drawings shall show the required attachments for the trusses.
- Any chords or truss webs shown on these drawings have been shown as a reference only. The final design of the trusses shall be per the manufacturer.

WOOD STRUCTURAL PANELS:

- Fabrication and placement of structural wood sheathing shall be in accordance with the APA Design/Construction Guide "Residential and Commercial," and all other applicable APA standards.
- All structurally required wood sheathing shall bear the mark of the APA.
- Wood wall sheathing shall comply with the requirements of local building codes for the appropriate state as indicated on these drawings. Refer to wall bracing notes in plan set for more information. Sheathing shall be applied with the long direction perpendicular to framing, unless noted otherwise.
- Roof sheathing shall be APA rated sheathing exposure 1 or 2. Roof sheathing shall be continuous over two supports and attached to its supporting roof framing with (1)-8d CC nail at 6"o/c at panel edges and at 12"o/c in panel field unless otherwise noted on the plans. Sheathing shall be applied with the long direction perpendicular to framing. Sheathing shall have a span rating consistent with the framing spacing. Use suitable edge support by use of plywood clips or lumber blocking unless otherwise noted. Panel end joints shall occur over framing. Apply building paper over the sheathing as required by the state Building Code.
- Wood floor sheathing shall be APA rated sheathing exposure 1 or 2. Attach sheathing to its supporting framing with (1)-8d CC ringshank nail at 6"o/c at panel edges and at 12"o/c in panel field unless otherwise noted on the plans. Sheathing shall be applied perpendicular to framing. Sheathing shall have a span rating consistent with the framing spacing. Use suitable edge support by use of T&G plywood or lumber blocking unless otherwise noted. Panel end joints shall occur over framing. Apply building paper over the sheathing as required by the state Building Code.
- Sheathing shall have a 1/8" gap at panel ends and edges as recommended in accordance with the APA.

STRUCTURAL FIBERBOARD PANELS:

- Fabrication and placement of structural fiberboard sheathing shall be in accordance with the applicable AFA standards.
- Fiberboard wall sheathing shall comply with the requirements of local building codes for the appropriate state as indicated on these drawings. Refer to wall bracing notes in plan set for more information.
- Sheathing shall have a 1/8" gap at panel ends and edges are recommended in accordance with the AFA.

EXTERIOR WOOD FRAMED DECKS:

- Decks are to be framed in accordance with local building codes and as referenced on the structural plans, either through code references or construction details.

STRUCTURAL STEEL:

- Structural steel shall be fabricated and erected in accordance with the American Institute of Steel Construction "Code of Standard Practice for Steel Buildings and Bridges" and of the manual of Steel Construction "Load Resistance Factor Design" latest editions.
- All steel shall have a minimum yield stress (Fy) of 36 ksi unless otherwise noted.
- Welding shall conform to the latest edition of the American Welding Society's Structural Welding Code AWS D1.1. Electrodes for shop and field welding shall be class E70XX. All welding shall be performed by a certified welder per the above standards.

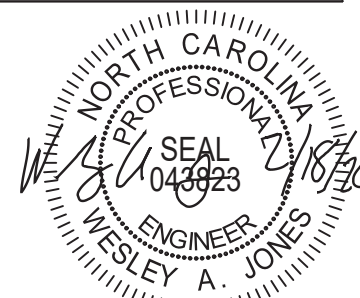

STRUCTURAL MEMBERS ONLY

SUMMIT
ENGINEERING LABORATORY TESTING
3070 HAMMOND BUSINESS PLACE,
SUITE 171, RALEIGH, NC 27603
OFFICE: 919.380.9991
FAX: 919.380.9993
WWW.SUMMIT-COMPANIES.COM

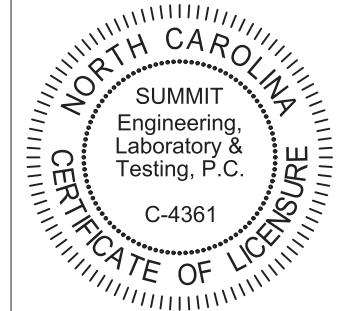

PROJECT
Standard Details
Notes and Specifications
CLIENT
Smith Douglas Homes
110 Village Trail, Suite 215
Woodstock, GA 30188

CURRENT DRAWING

DATE: 2/18/20
SCALE: NTS
PROJECT #: 3832
DRAWN BY: LBV
CHECKED BY: WAJ

ORIGINAL DRAWING

| NO. | DATE | PROJECT # |
|-----|--------|-----------|
| 0 | 1/7/16 | 3832 |

REFER TO COVER SHEET FOR A COMPLETE LIST OF REVISIONS

SHEET

CS2

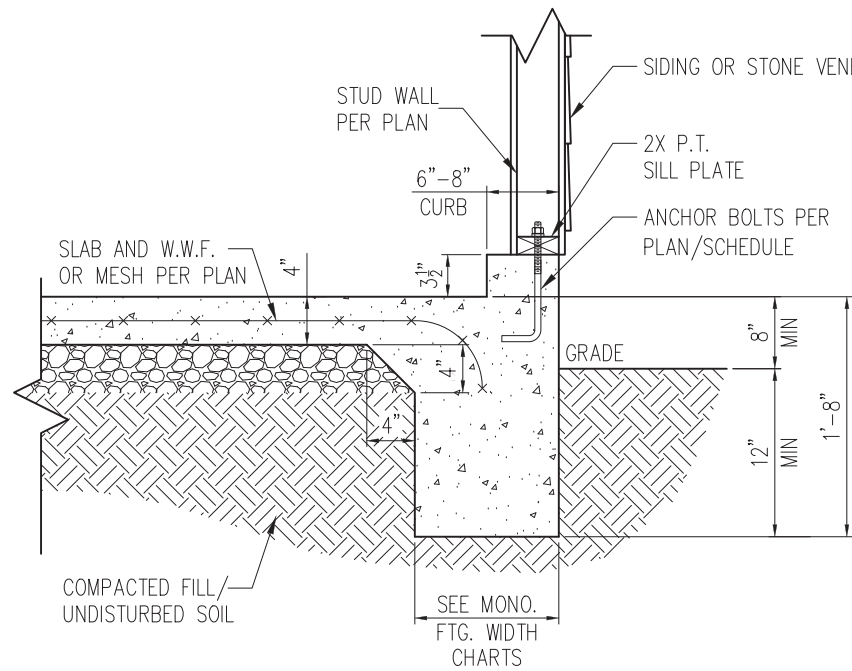

STANDARD - SIDING/STONE

1 TYP. GARAGE CURB DETAIL
D1m 3/4" = 1'-0"

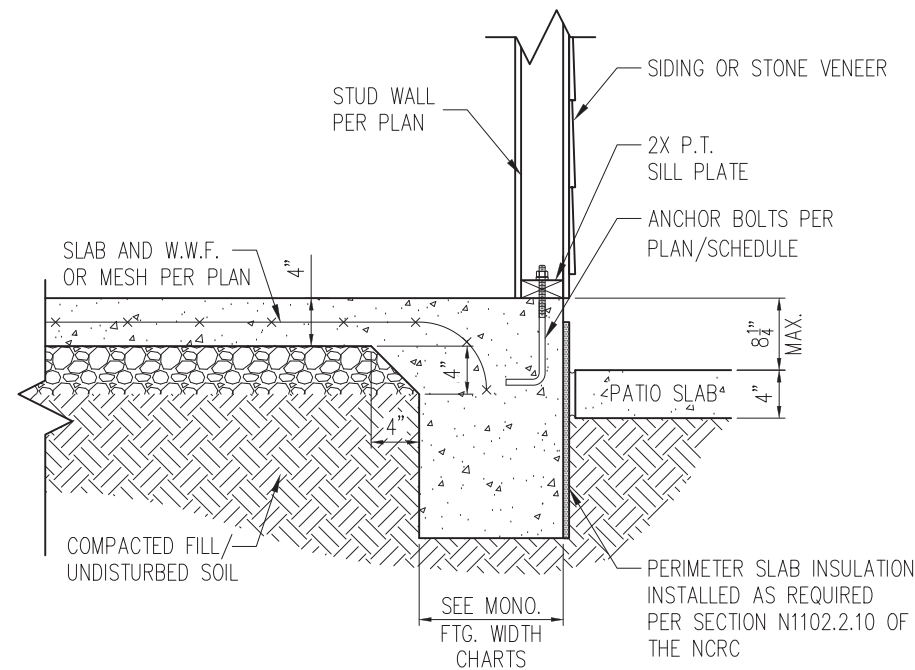

STANDARD - SIDING/STONE

2 PATIO SLAB DETAIL
D1m 3/4" = 1'-0"

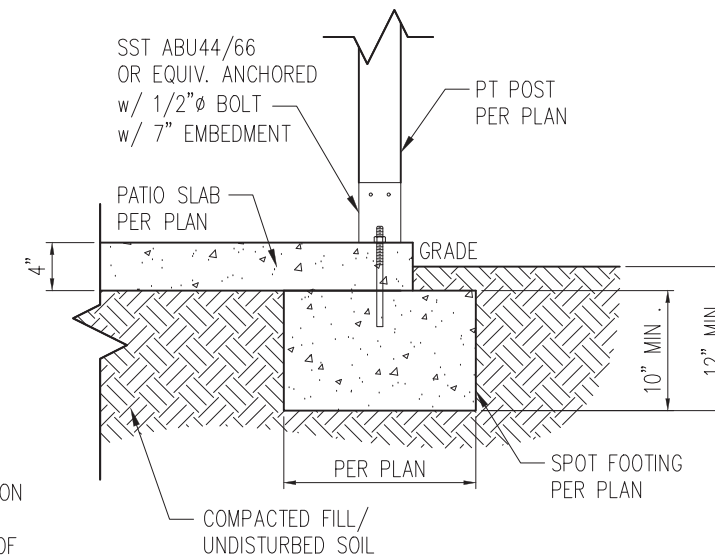

2A COVERED PATIO DETAIL
D1m 3/4" = 1'-0"

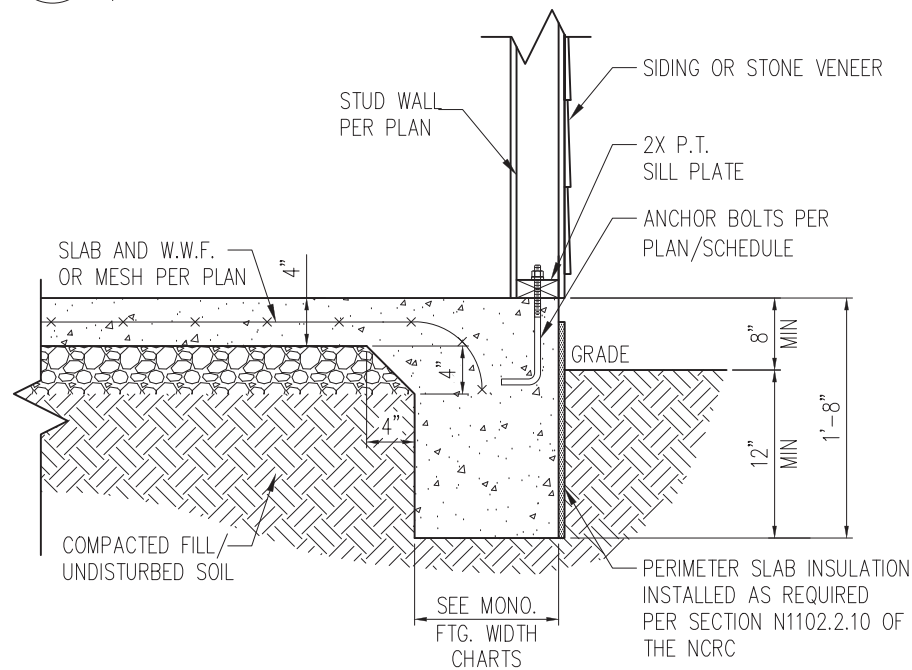

STANDARD - SIDING/STONE

3 TYP. SLAB DETAIL
D1m 3/4" = 1'-0"

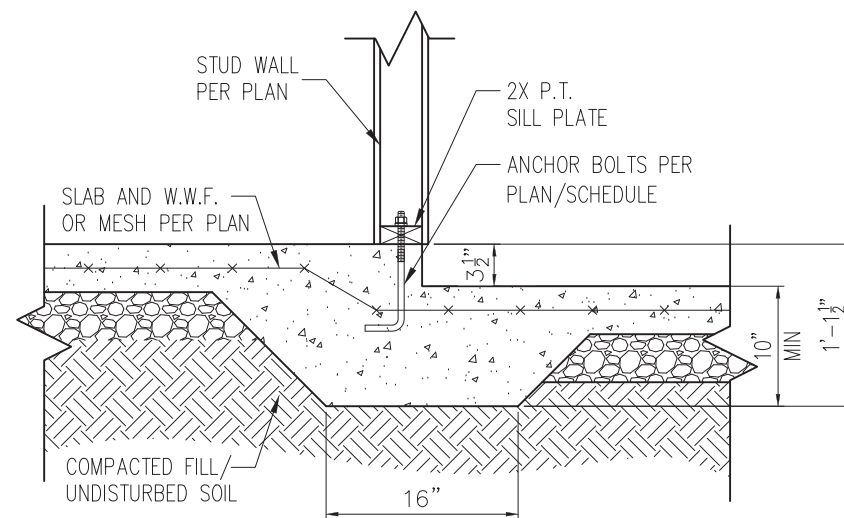

4 STEP IN GARAGE
D1m 3/4" = 1'-0"

- NOTES:
- REFER TO GENERAL NOTES & SPECIFICATIONS ON SHEET CS2 FOR ADDITIONAL INFORMATION.
 - PROVIDE 6 MIL VAPOR BARRIER UNDER ALL SLABS-ON-GRADE.
 - SEE ARCH. DWGS. FOR ALL TOP OF THE SLAB ELEVATIONS, SLOPES AND DEPRESSIONS.

WALL ANCHOR SCHEDULE

| TYPE OF ANCHOR | MIN. CONC. EMBEDMENT | SPACING EMBEDMENT | INTERIOR WALL | EXTERIOR WALL |
|---|----------------------|-------------------|---------------|---------------|
| 1/2" A307 BOLTS w/ STD. 90° BEND | 7" | 6'-0" | YES | YES |
| SST - MAS | 4" | 5'-0" | NO | YES |
| HILTI KWIK BOLT KBI 1/2-2-3/4 | 2-1/4" | 6'-0" | YES | NO |
| 1/2" HILTI THREADED ROD w/ HIT HY150 ADHESIVE | 7" | 6'-0" | YES | YES |

NOTE: INSTALL ALL ANCHORS 12" MAX. FROM ALL BOTTOM PLATE ENDS AND JOINTS.

MONOLITHIC FOOTING WIDTH

| # OF STORIES | WIDTH BASED ON SOIL BEARING CAPACITY | | |
|------------------------|--------------------------------------|----------|----------|
| | 1500 PSF | 2000 PSF | 2500 PSF |
| 1 STORY - STD. | 16" | 16" | 16" |
| 1 STORY - BRICK VENEER | 21" | 21" | 21" |
| 2 STORY - STD. | 20" | 16" | 16" |
| 2 STORY - BRICK VENEER | 25" | 21" | 21" |

*5" BRICK LEDGE HAS BEEN ADDED TO THE MONOLITHIC FOOTING WIDTH FOR BRICK SUPPORT

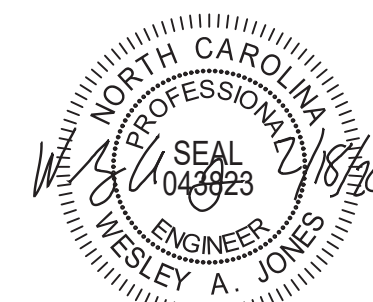

STRUCTURAL MEMBERS ONLY

SUMMIT
ENGINEERING LABORATORY TESTING
3070 HAMMOND BUSINESS PLACE,
SUITE 171, RALEIGH, NC 27603
OFFICE: 919.380.9991
FAX: 919.380.9993
WWW.SUMMIT-COMPANIES.COM

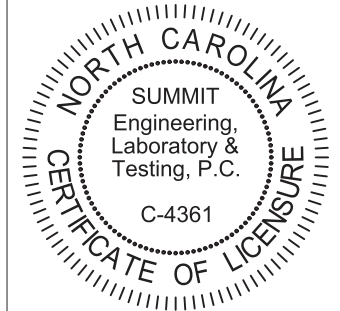

PROJECT
Standard Details
Monolithic Slab Details
CLIENT
Smith Douglas Homes
110 Village Trail, Suite 215
Woodstock, GA 30188

CURRENT DRAWING
DATE: 2/18/20
SCALE: NTS
PROJECT #: 3832
DRAWN BY: LBV
CHECKED BY: WAJ

ORIGINAL DRAWING
NO. DATE PROJECT #
0 1/7/16 3832

REFER TO COVER SHEET FOR A COMPLETE LIST OF REVISIONS

SHEET

D1m

*BRICK TIES SPACED @ 16" O.C. HORIZ. & 24" O.C. VERT. AND 3/16" Ø WEEP HOLES @ 33" O.C.

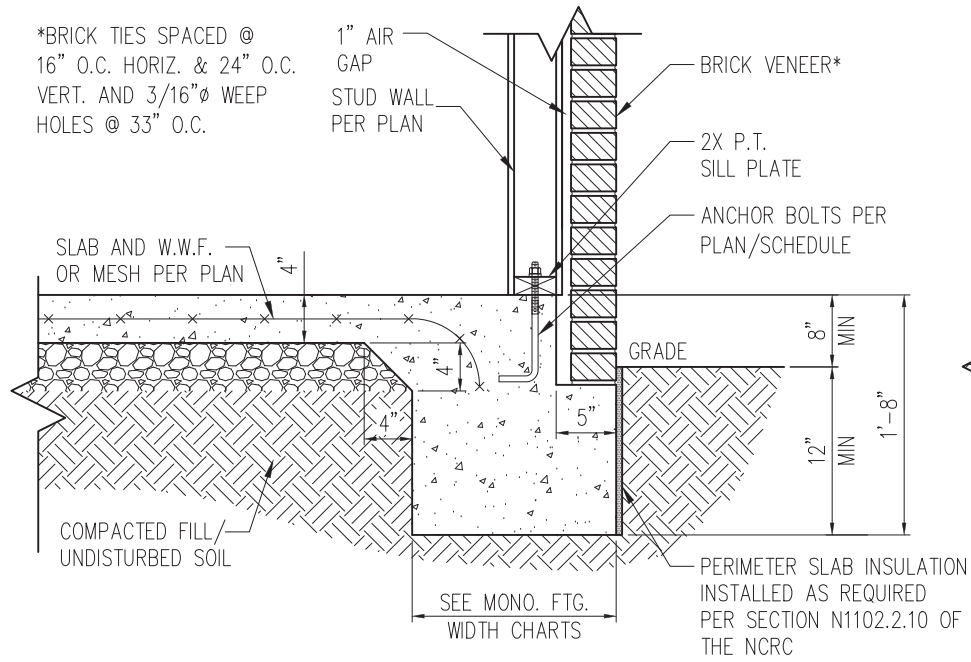

STANDARD - BRICK

1 TYP. SLAB DETAIL W/ BRICK VENEER
D2m 3/4" = 1'-0"

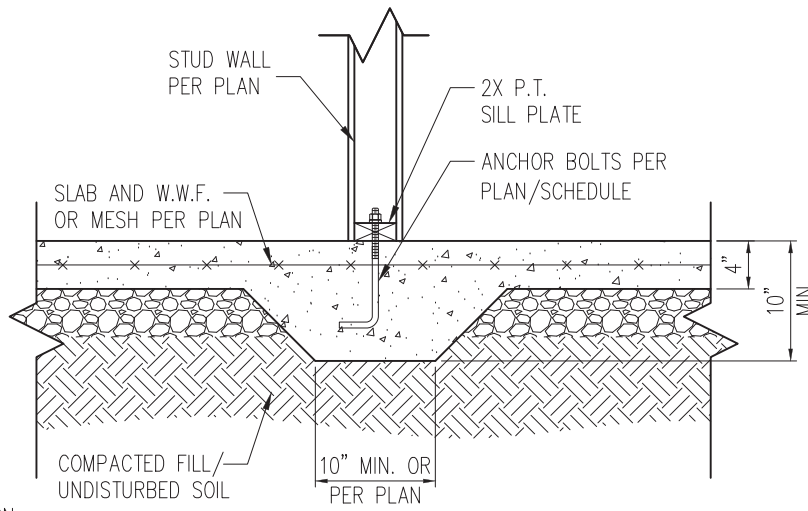

3 TYP. THICKENED SLAB DETAIL
D2m 3/4" = 1'-0"

*BRICK TIES SPACED @ 16" O.C. HORIZ. & 24" O.C. VERT. AND 3/16" Ø WEEP HOLES @ 33" O.C.

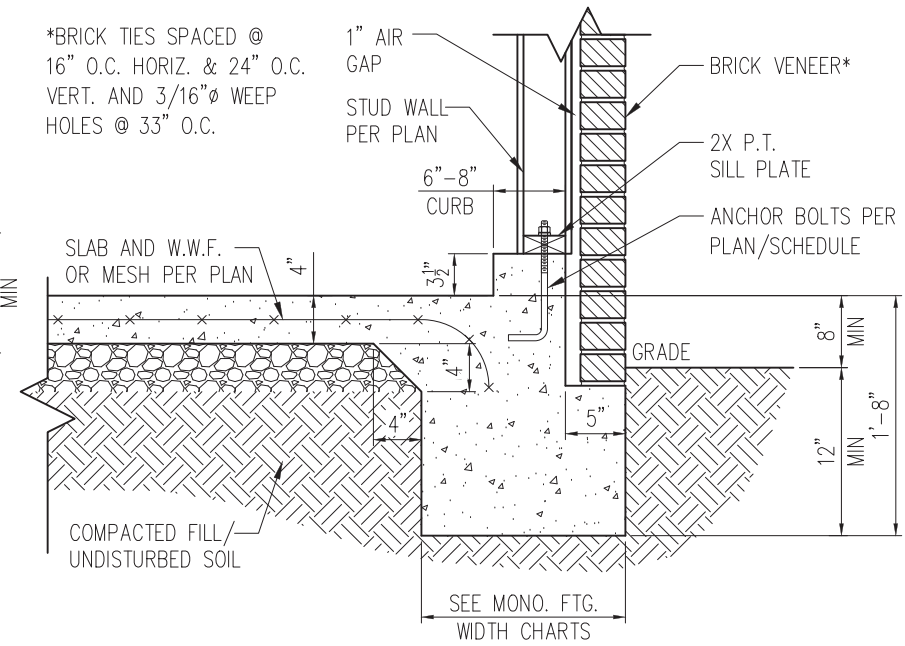

STANDARD - BRICK

5 TYP. GARAGE CURB DETAIL W/ BRICK VENEER
D2m 3/4" = 1'-0"

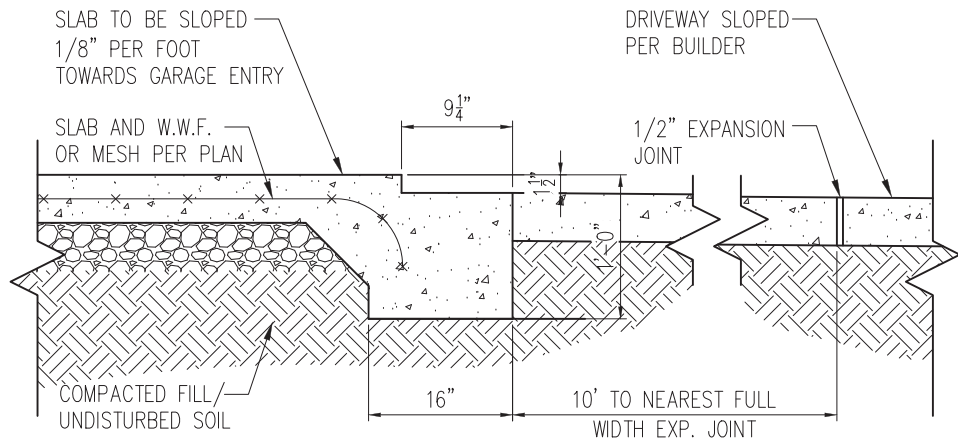

2 SLAB AT GARAGE DOOR
D2m 3/4" = 1'-0"

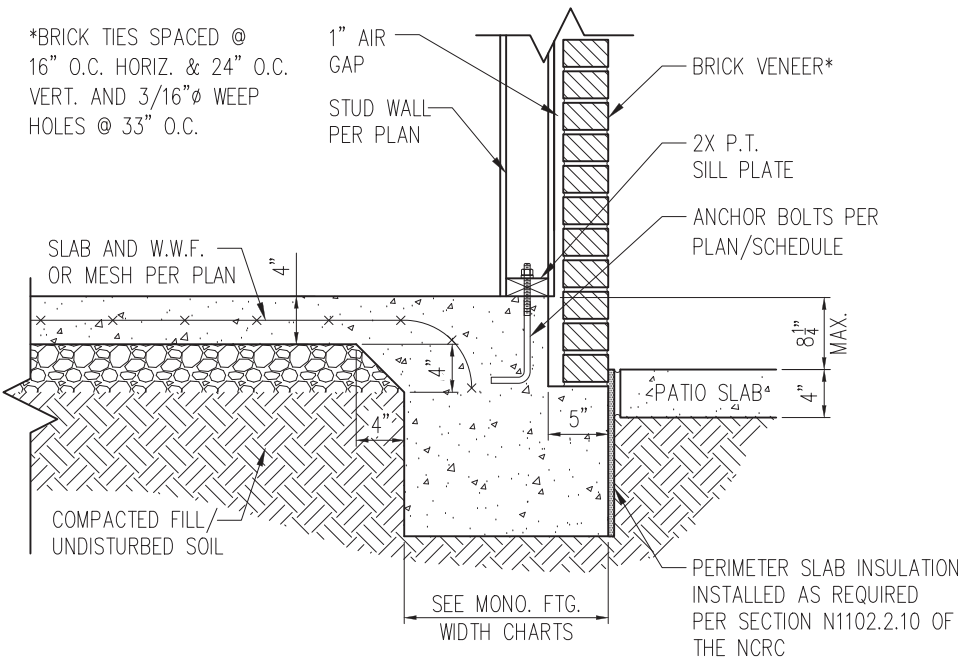

STANDARD - BRICK

4 PATIO SLAB DETAIL W/ BRICK VENEER
D2m 3/4" = 1'-0"

NOTES:

1. REFER TO GENERAL NOTES & SPECIFICATIONS ON SHEET CS2 FOR ADDITIONAL INFORMATION.
2. PROVIDE 6 MIL VAPOR BARRIER UNDER ALL SLABS-ON-GRADE.
3. SEE ARCH. DWGS. FOR ALL TOP OF THE SLAB ELEVATIONS, SLOPES AND DEPRESSIONS.



STRUCTURAL MEMBERS ONLY

SUMMIT
ENGINEERING LABORATORY TESTING
3070 HAMMOND BUSINESS PLACE,
SUITE 171, RALEIGH, NC 27603
OFFICE: 919.380.9991
FAX: 919.380.9993
WWW.SUMMIT-COMPANIES.COM

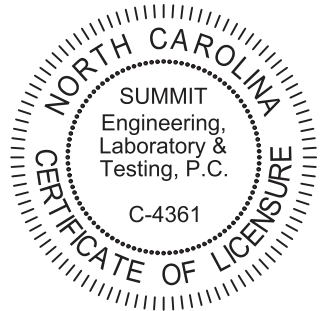

PROJECT
Standard Details
Monolithic Slab Details
CLIENT
Smith Douglas Homes
110 Village Trail, Suite 215
Woodstock, GA 30188

CURRENT DRAWING
DATE: 2/18/20
SCALE: NTS
PROJECT #: 3832
DRAWN BY: LBV
CHECKED BY: WAJ

ORIGINAL DRAWING
NO. DATE PROJECT #
0 1/7/16 3832

REFER TO COVER SHEET FOR A COMPLETE LIST OF REVISIONS

SHEET
D2m

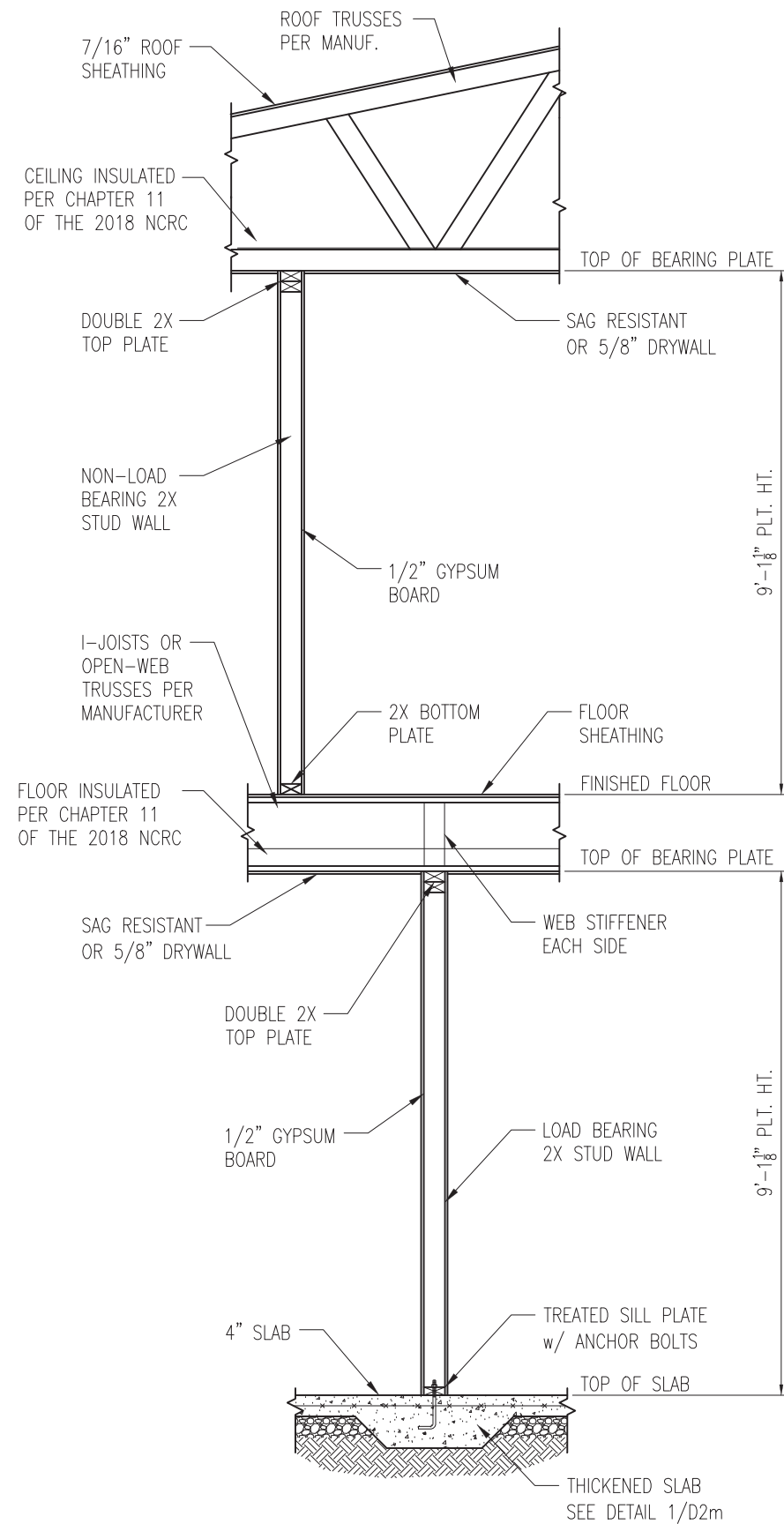

1 TYP. INTERIOR LOAD BEARING WALL SECTION
 D3m 3/4" = 1'-0"

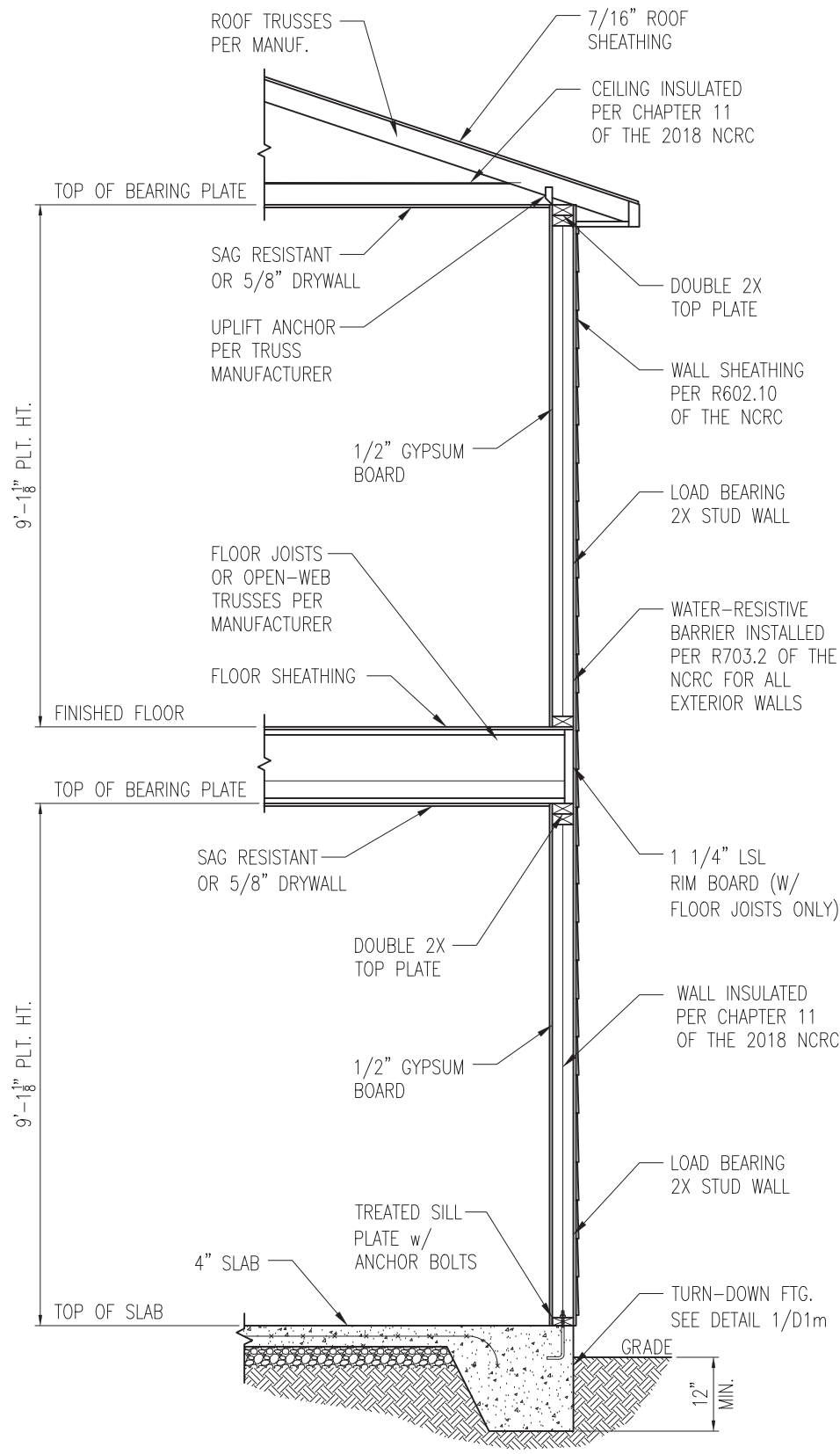

2 TYP. EXTERIOR LOAD BEARING WALL SECTION
 D3m 3/4" = 1'-0"
 -SIMILAR w/ BRICK AND STONE
 -BRICK TIES SPACED @ 16" O.C. HORIZ. & 24" O.C. VERT.
 -MIN. 3/16" Ø WEEP HOLES @ 33" O.C.

- NOTES:
1. REFER TO GENERAL NOTES & SPECIFICATIONS ON SHEET CS2 FOR ADDITIONAL INFORMATION.
 2. PROVIDE 6 MIL VAPOR BARRIER UNDER ALL SLABS-ON-GRADE.
 3. SEE ARCH. DWGS. FOR ALL TOP OF THE SLAB ELEVATIONS, SLOPES AND DEPRESSIONS.



STRUCTURAL MEMBERS ONLY

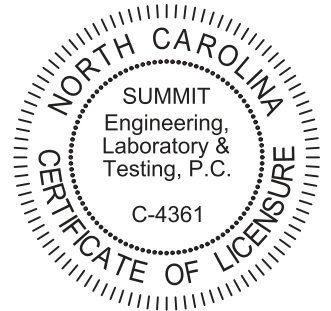

PROJECT
Standard Details
Monolithic Slab Details
 CLIENT
Smith Douglas Homes
 110 Village Trail, Suite 215
 Woodstock, GA 30188

CURRENT DRAWING
 DATE: 2/18/20
 SCALE: NTS
 PROJECT #: 3832
 DRAWN BY: LBV
 CHECKED BY: WAJ

ORIGINAL DRAWING
 NO. DATE PROJECT #
 0 1/7/16 3832

REFER TO COVER SHEET FOR A COMPLETE LIST OF REVISIONS

SHEET
D3m

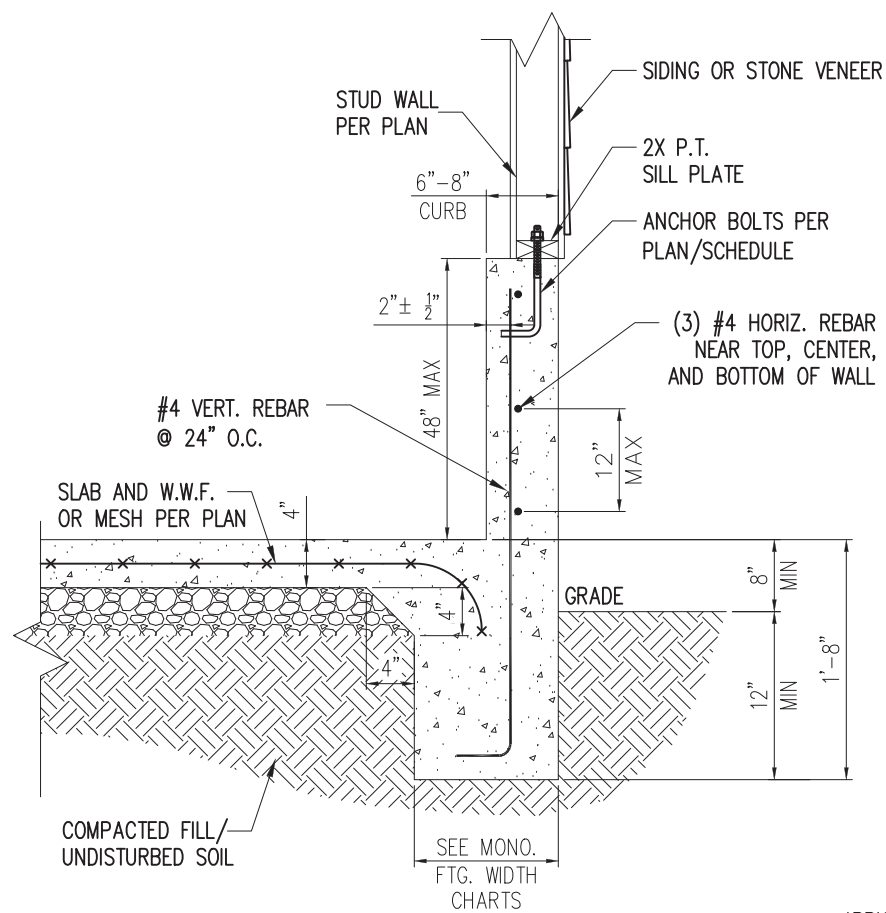

STANDARD - SIDING/STONE

1 EXTENDED GARAGE CURB DETAIL
D4m NTS

*BRICK TIES SPACED @
16" O.C. HORIZ. & 24" O.C.
VERT. AND 3/16" Ø WEEP
HOLES @ 33" O.C.

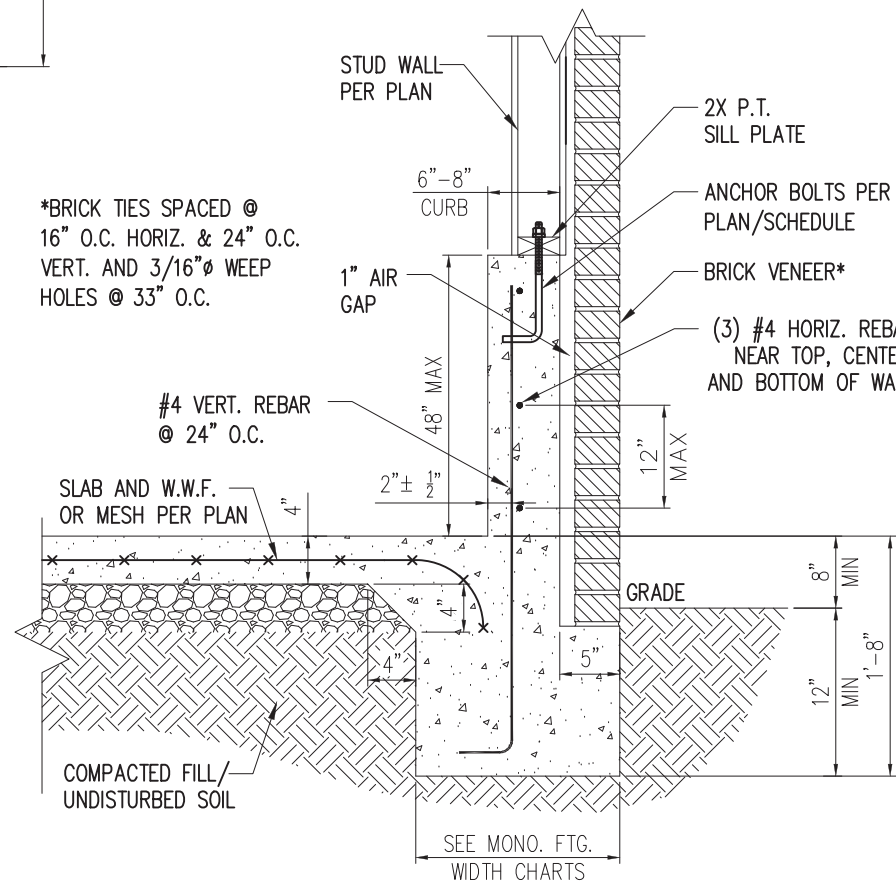

STANDARD - BRICK

3 EXTENDED GARAGE CURB DETAIL
W/ BRICK VENEER
D4m NTS

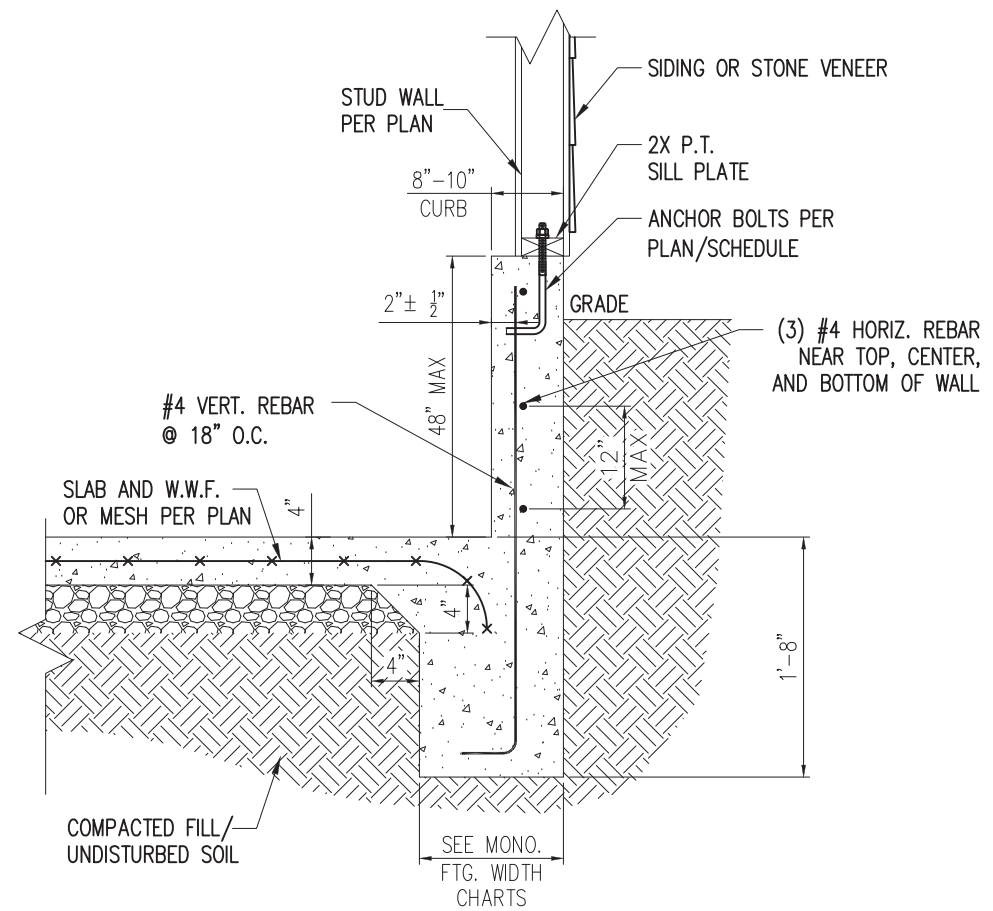

STANDARD - SIDING/STONE

2 EXTENDED GARAGE CURB DETAIL
W/ UNBALANCED FILL
D4m NTS



STRUCTURAL MEMBERS ONLY

SUMMIT
ENGINEERING LABORATORY TESTING
3070 HAMMOND BUSINESS PLACE,
SUITE 171, RALEIGH, NC 27603
OFFICE: 919.380.9991
FAX: 919.380.9993
WWW.SUMMIT-COMPANIES.COM

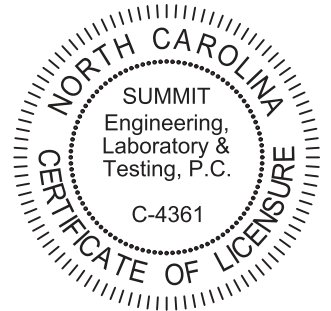

PROJECT
Standard Details
Monolithic Slab Details
CLIENT
Smith Douglas Homes
110 Village Trail, Suite 215
Woodstock, GA 30188

CURRENT DRAWING
DATE: 2/18/20
SCALE: NTS
PROJECT #: 3832
DRAWN BY: LBV
CHECKED BY: WAJ

ORIGINAL DRAWING
NO. DATE PROJECT #
0 1/7/16 3832

REFER TO COVER SHEET FOR A
COMPLETE LIST OF REVISIONS

SHEET
D4m

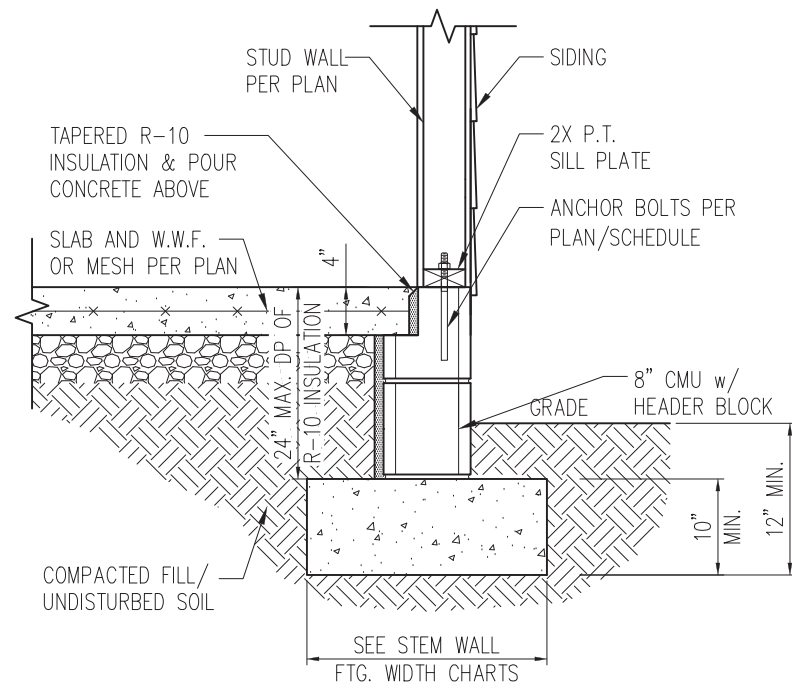

STANDARD - SIDING

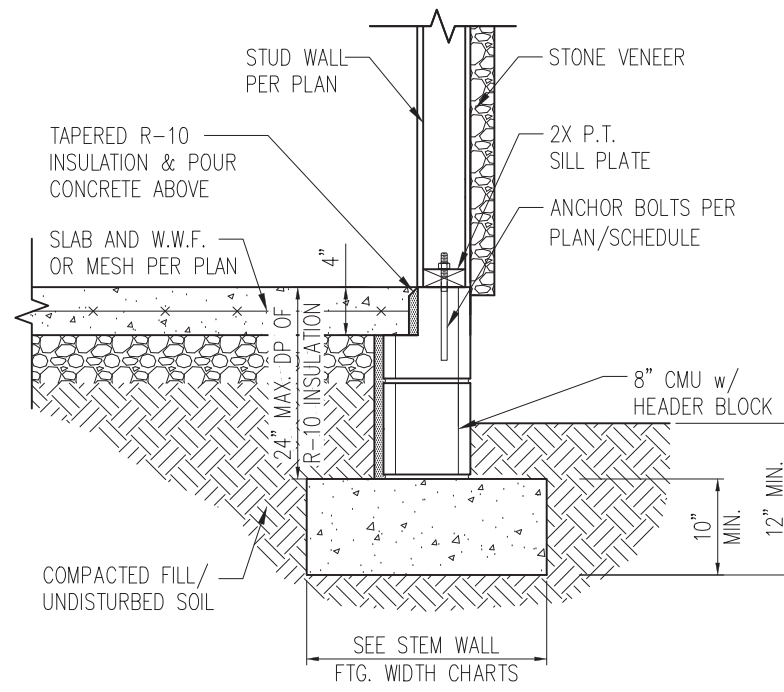

STANDARD - STONE

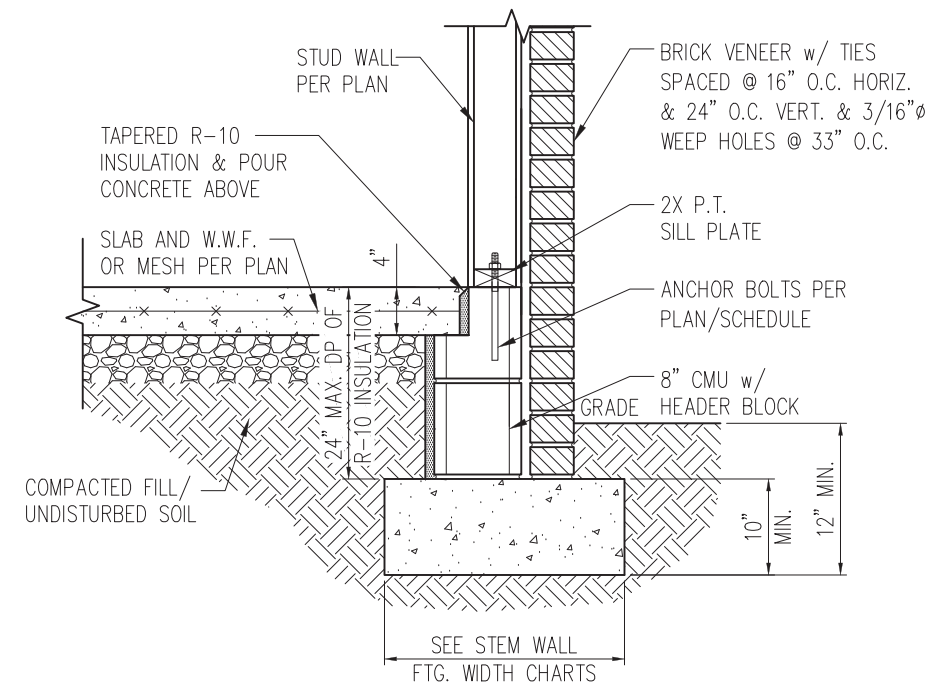

STANDARD - BRICK

1 TYP. STEM WALL DETAIL
D1s 3/4" = 1'-0"

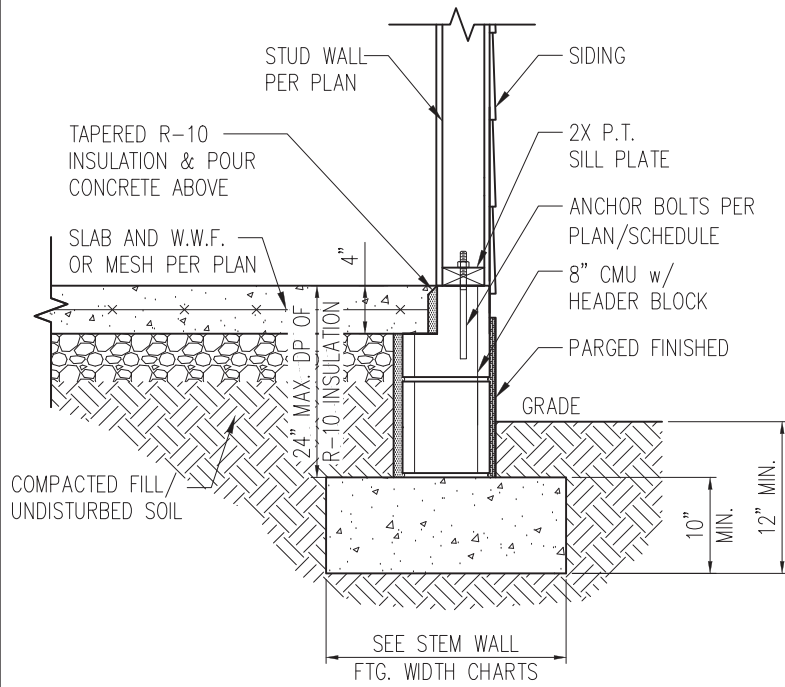

STANDARD - SIDING

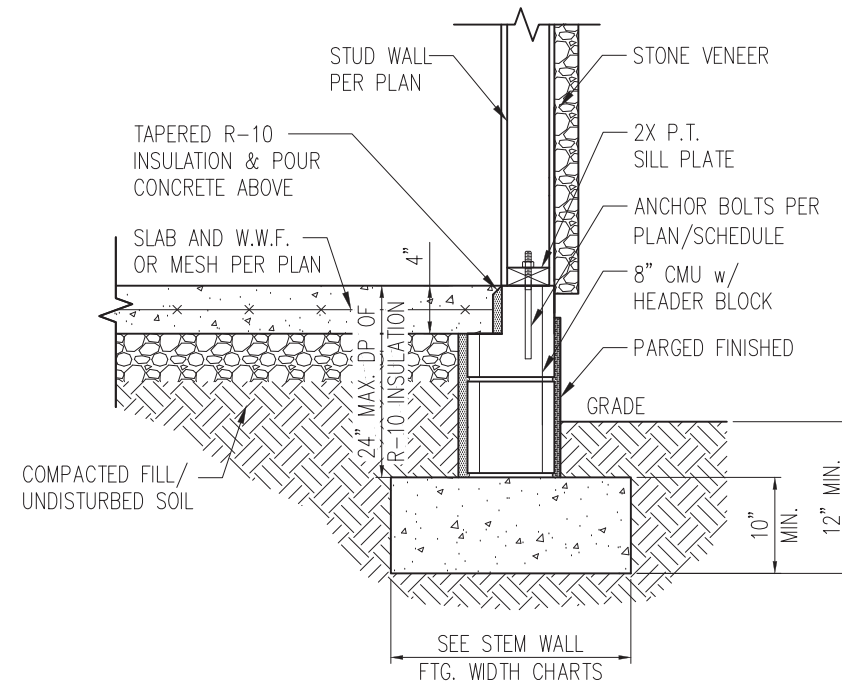

STANDARD - STONE

1a STEM WALL DETAIL w/ PARGED FINISH
D1s 3/4" = 1'-0"

STEM WALL FOOTING WIDTH

| # OF STORIES | WIDTH BASED ON SOIL BEARING CAPACITY | | |
|------------------------|--------------------------------------|----------|----------|
| | 1500 PSF | 2000 PSF | 2500 PSF |
| 1 STORY - STD. | 16" | 16" | 16" |
| 1 STORY - BRICK VENEER | 21"* | 21"* | 21"* |
| 2 STORY - STD. | 20" | 16" | 16" |
| 2 STORY - BRICK VENEER | 25"* | 21"* | 21"* |

*5" BRICK LEDGE HAS BEEN ADDED TO THE STEM WALL FOOTING WIDTH FOR BRICK SUPPORT

WALL ANCHOR SCHEDULE

| TYPE OF ANCHOR | MIN. CONC. EMBEDMENT | SPACING EMBEDMENT | INTERIOR WALL | EXTERIOR WALL |
|---|----------------------|-------------------|---------------|---------------|
| 1/2" A307 BOLTS w/ STD. 90° BEND | 7" | 6'-0" | YES | YES |
| SST - MAS | 4" | 5'-0" | NO | YES |
| HILTI KWIK BOLT KBI 1/2-2-3/4 | 2-1/4" | 6'-0" | YES | NO |
| 1/2" HILTI THREADED ROD w/ HIT HY150 ADHESIVE | 7" | 6'-0" | YES | YES |

NOTE: INSTALL ALL ANCHORS 12" MAX. FROM ALL BOTTOM PLATE ENDS AND JOINTS.

NOTES:

- REFER TO GENERAL NOTES & SPECIFICATIONS ON SHEET CS2 FOR ADDITIONAL INFORMATION.
- PROVIDE 6 MIL VAPOR BARRIER UNDER ALL SLABS-ON-GRADE.
- SEE ARCH. DWGS. FOR ALL TOP OF THE SLAB ELEVATIONS, SLOPS AND DEPRESSIONS.

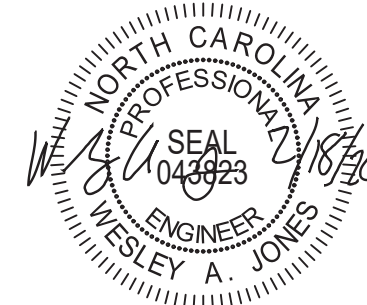

STRUCTURAL MEMBERS ONLY

SUMMIT
ENGINEERING LABORATORY TESTING
3070 HAMMOND BUSINESS PLACE,
SUITE 171, RALEIGH, NC 27603
OFFICE: 919.380.9991
FAX: 919.380.9993
WWW.SUMMIT-COMPANIES.COM

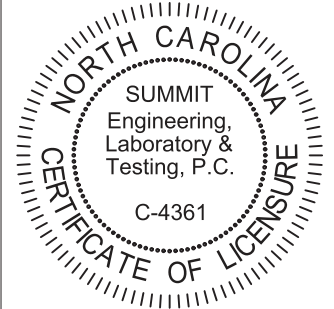

PROJECT
Standard Details
Stemwall Details
CLIENT
Smith Douglas Homes
110 Village Trail, Suite 215
Woodstock, GA 30188

CURRENT DRAWING

DATE: 2/18/20
SCALE: NTS
PROJECT #: 3832
DRAWN BY: LBV
CHECKED BY: WAJ

ORIGINAL DRAWING

| NO. | DATE | PROJECT # |
|-----|--------|-----------|
| 0 | 1/7/16 | 3832 |

REFER TO COVER SHEET FOR A COMPLETE LIST OF REVISIONS

SHEET

D1s

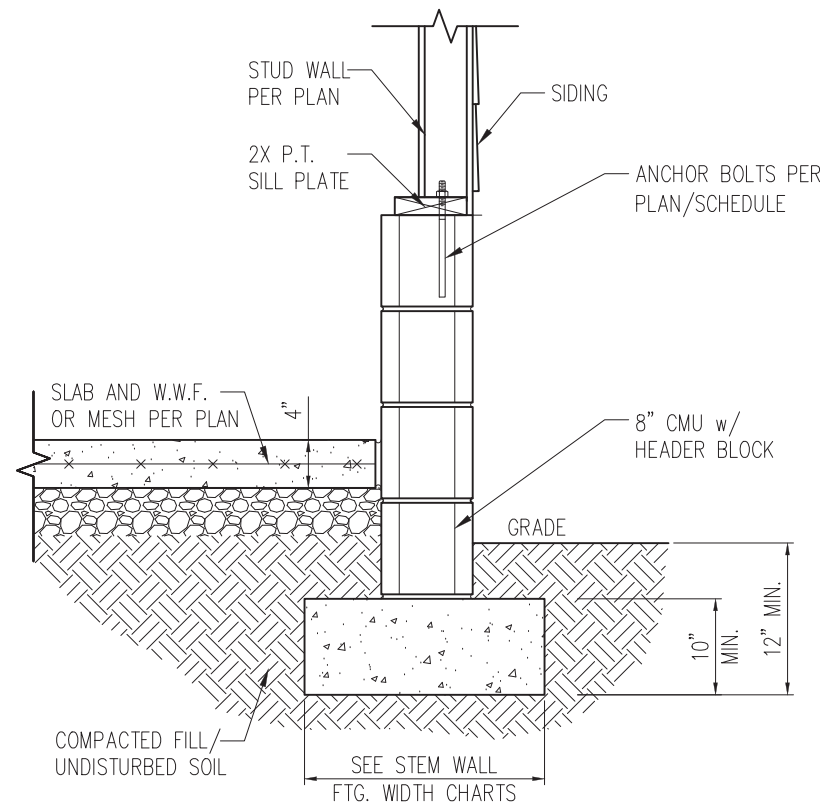

STANDARD - SIDING

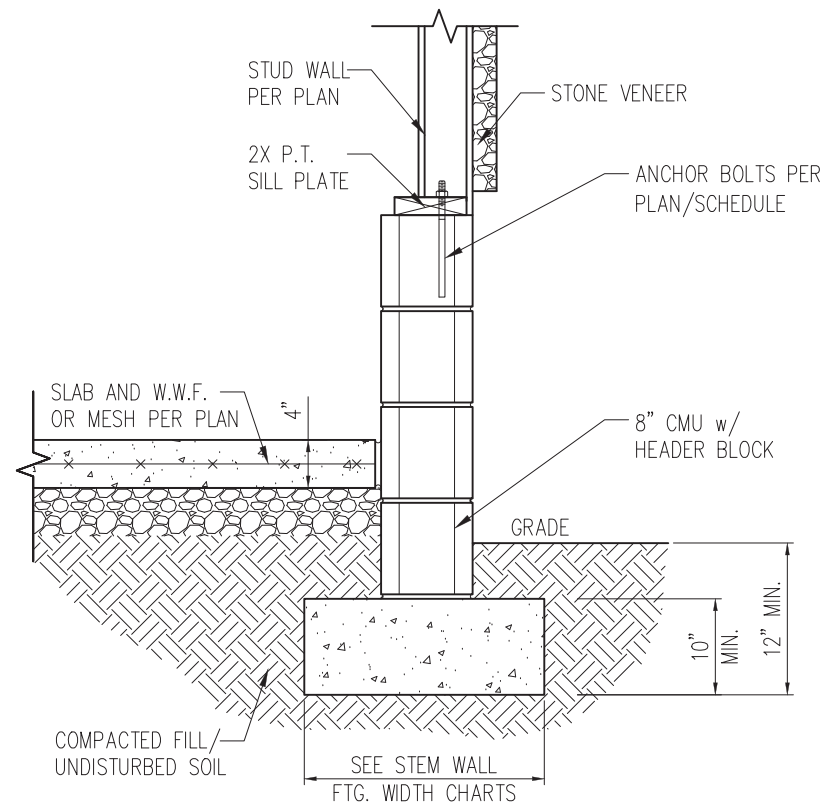

STANDARD - STONE

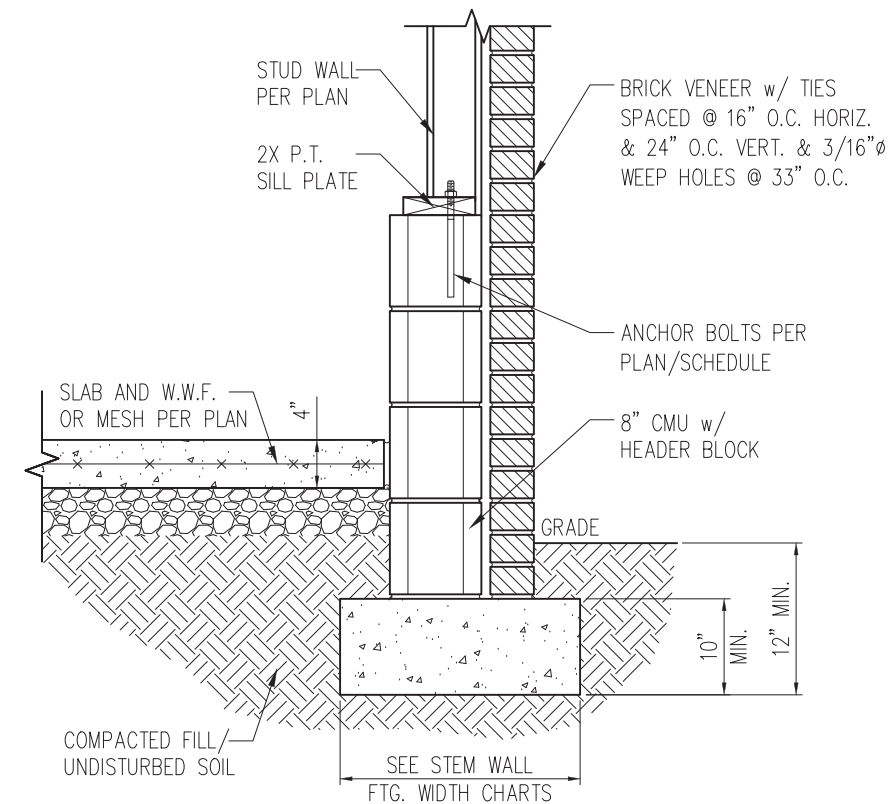

STANDARD - BRICK

1 TYP. GARAGE CURB DETAIL
D2s 3/4" = 1'-0"

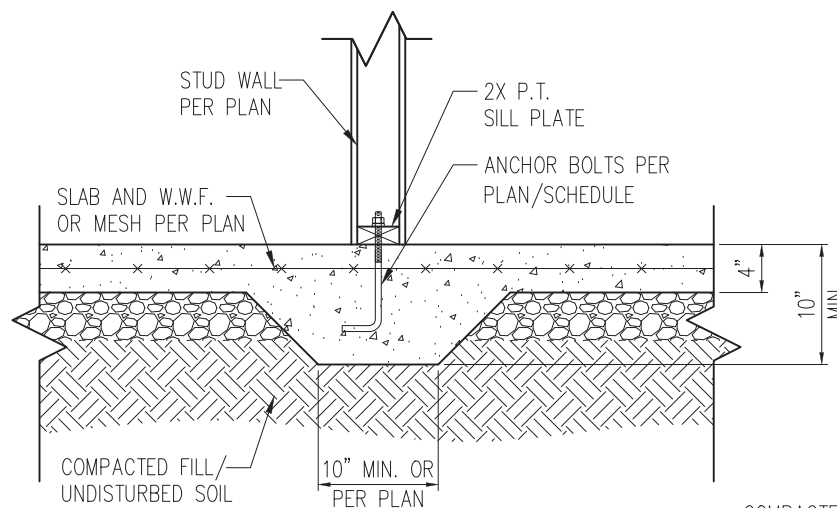

2 TYP. THICKENED SLAB DETAIL
D2s 3/4" = 1'-0"

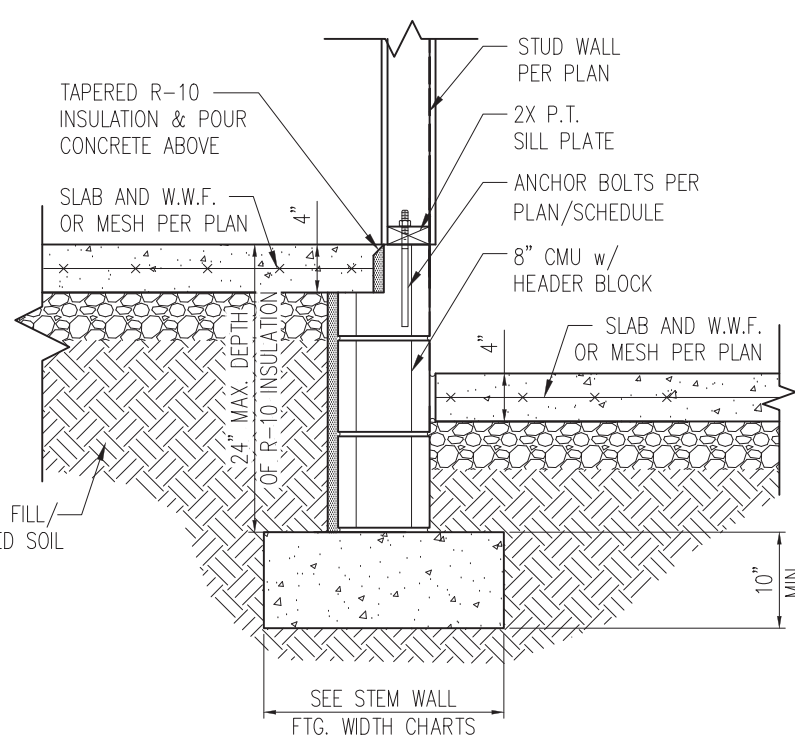

3 HOUSE/GARAGE WALL DETAIL
D2s 3/4" = 1'-0"

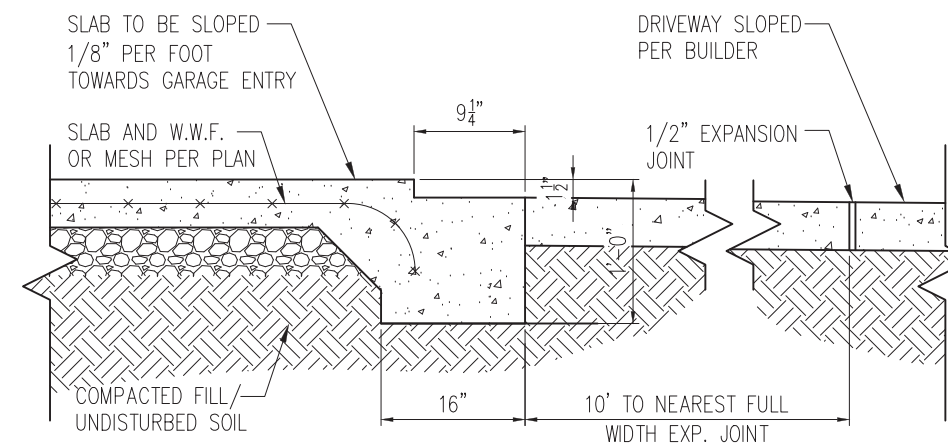

4 SLAB AT GARAGE DOOR
D2s 3/4" = 1'-0"

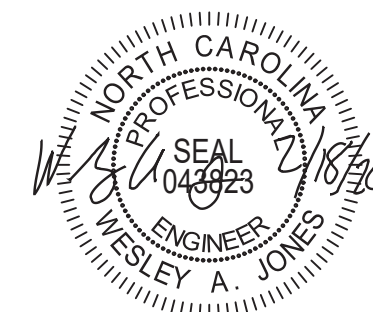

STRUCTURAL MEMBERS ONLY

SUMMIT
ENGINEERING LABORATORY TESTING
3070 HAMMOND BUSINESS PLACE,
SUITE 171, RALEIGH, NC 27603
OFFICE: 919.380.9991
FAX: 919.380.9993
WWW.SUMMIT-COMPANIES.COM

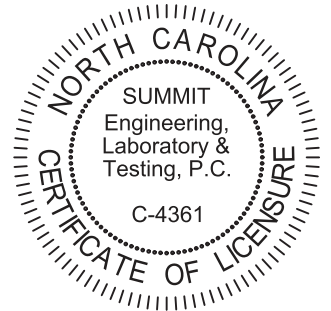

PROJECT
Standard Details
Stemwall Details
CLIENT
Smith Douglas Homes
110 Village Trail, Suite 215
Woodstock, GA 30188

CURRENT DRAWING
DATE: 2/18/20
SCALE: NTS
PROJECT #: 3832
DRAWN BY: LBV
CHECKED BY: WAJ
ORIGINAL DRAWING
NO. DATE PROJECT #
0 1/7/16 3832

REFER TO COVER SHEET FOR A COMPLETE LIST OF REVISIONS

SHEET
D2s

- NOTES:
1. REFER TO GENERAL NOTES & SPECIFICATIONS ON SHEET CS2 FOR ADDITIONAL INFORMATION.
2. PROVIDE 6 MIL VAPOR BARRIER UNDER ALL SLABS-ON-GRADE.
3. SEE ARCH. DWGS. FOR ALL TOP OF THE SLAB ELEVATIONS, SLOPES AND DEPRESSIONS.

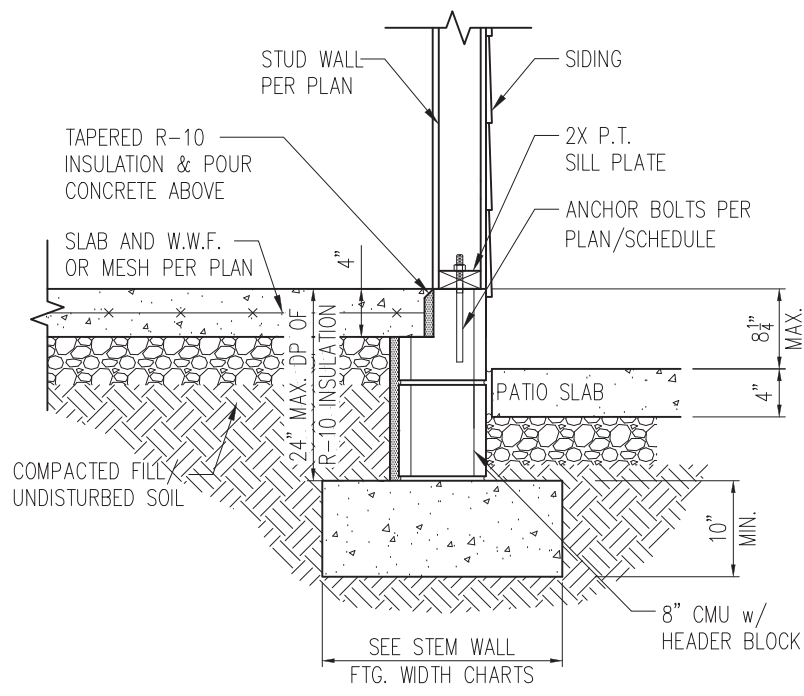

STANDARD - SIDING

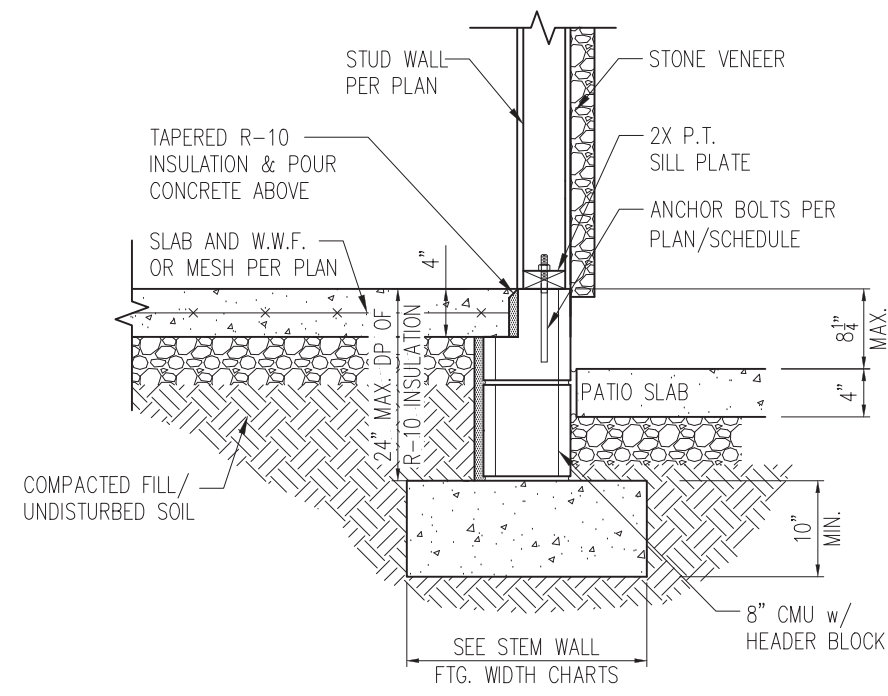

STANDARD - STONE

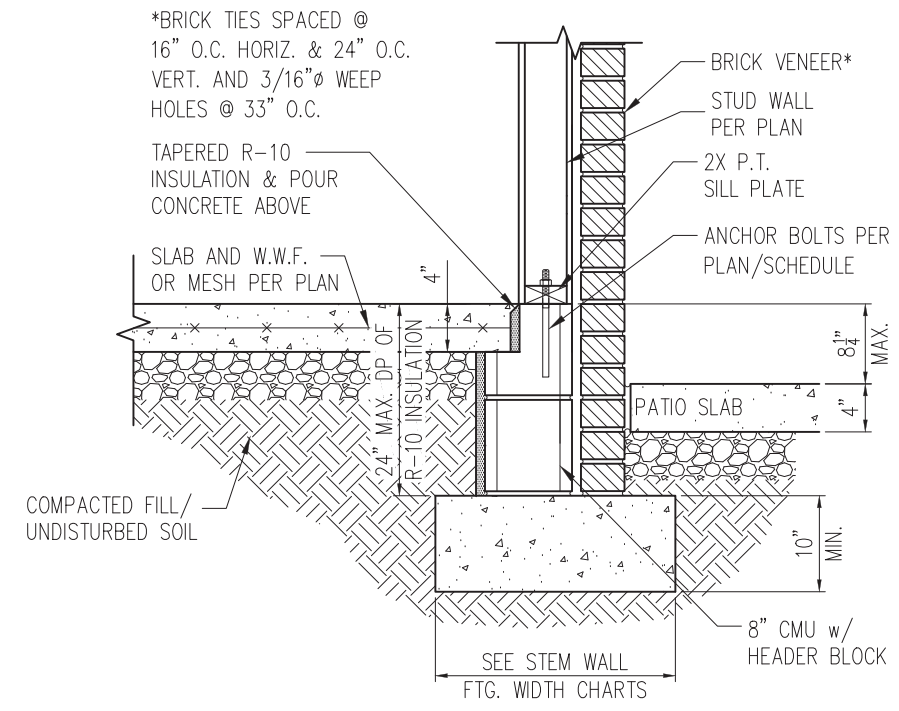

STANDARD - BRICK

1 PORCH SLAB DETAIL
D3s 3/4" = 1'-0"

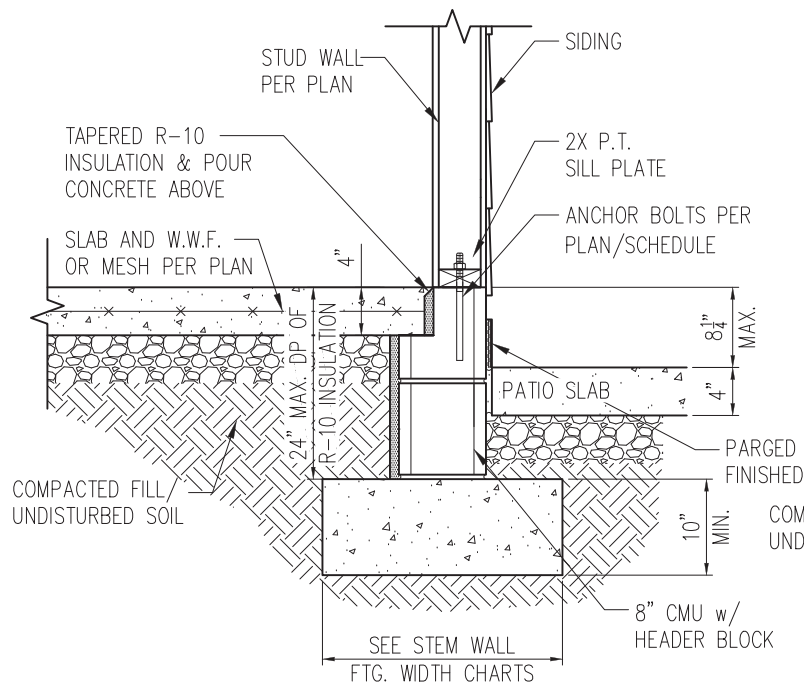

STANDARD - SIDING

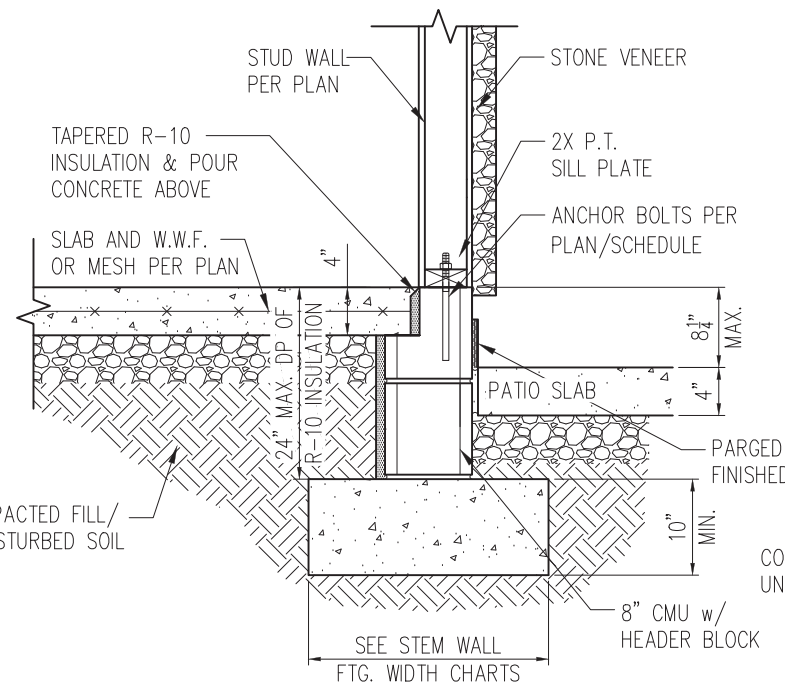

STANDARD - STONE

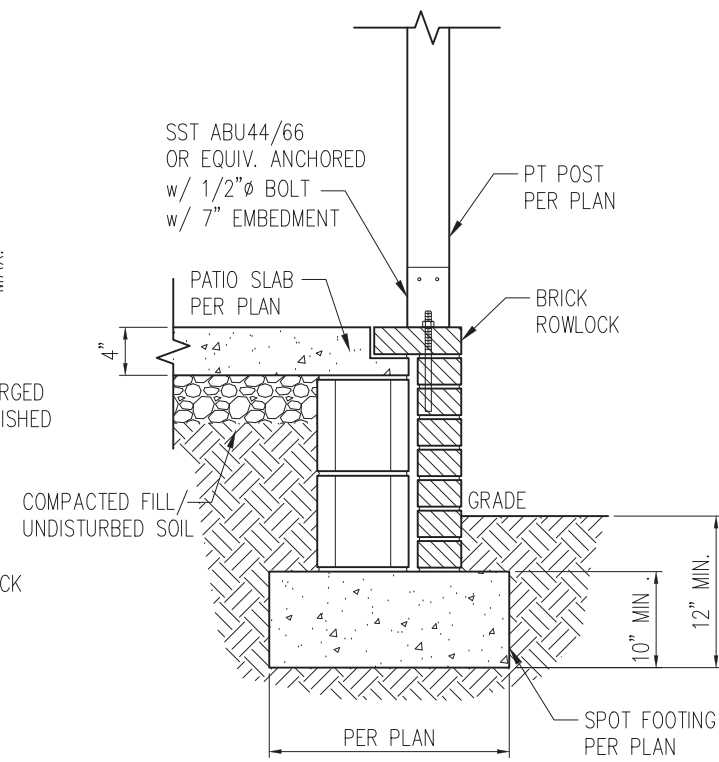

2 COVERED PORCH DETAIL
D3s 3/4" = 1'-0"

- NOTES:
1. REFER TO GENERAL NOTES & SPECIFICATIONS ON SHEET CS2 FOR ADDITIONAL INFORMATION.
 2. PROVIDE 6 MIL VAPOR BARRIER UNDER ALL SLABS-ON-GRADE.
 3. SEE ARCH. DWGS. FOR ALL TOP OF THE SLAB ELEVATIONS, SLOPES AND DEPRESSIONS.

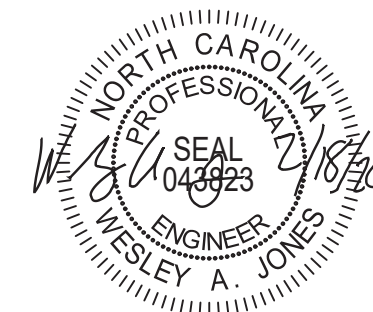

STRUCTURAL MEMBERS ONLY

SUMMIT
ENGINEERING LABORATORY TESTING
3070 HAMMOND BUSINESS PLACE,
SUITE 171, RALEIGH, NC 27603
OFFICE: 919.380.9991
FAX: 919.380.9993
WWW.SUMMIT-COMPANIES.COM

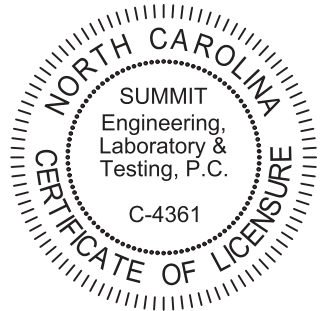

PROJECT
Standard Details
Stemwall Details
CLIENT
Smith Douglas Homes
110 Village Trail, Suite 215
Woodstock, GA 30188

CURRENT DRAWING
DATE: 2/18/20
SCALE: NTS
PROJECT #: 3832
DRAWN BY: LBV
CHECKED BY: WAJ

ORIGINAL DRAWING
NO. DATE PROJECT #
0 1/7/16 3832

REFER TO COVER SHEET FOR A COMPLETE LIST OF REVISIONS

SHEET
D3s

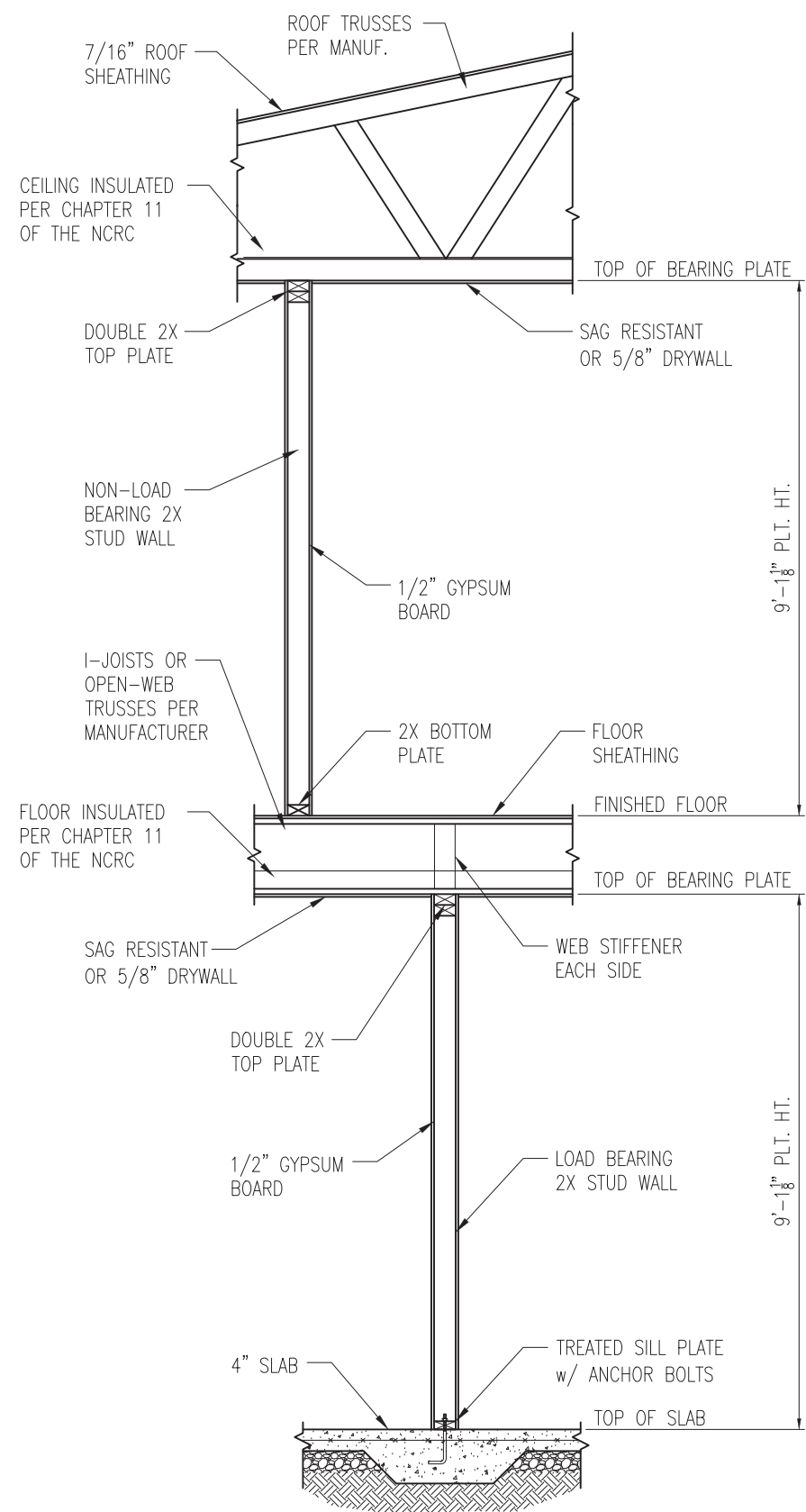

1 TYP. INTERIOR LOAD BEARING WALL SECTION
 D4s 3/4" = 1'-0"

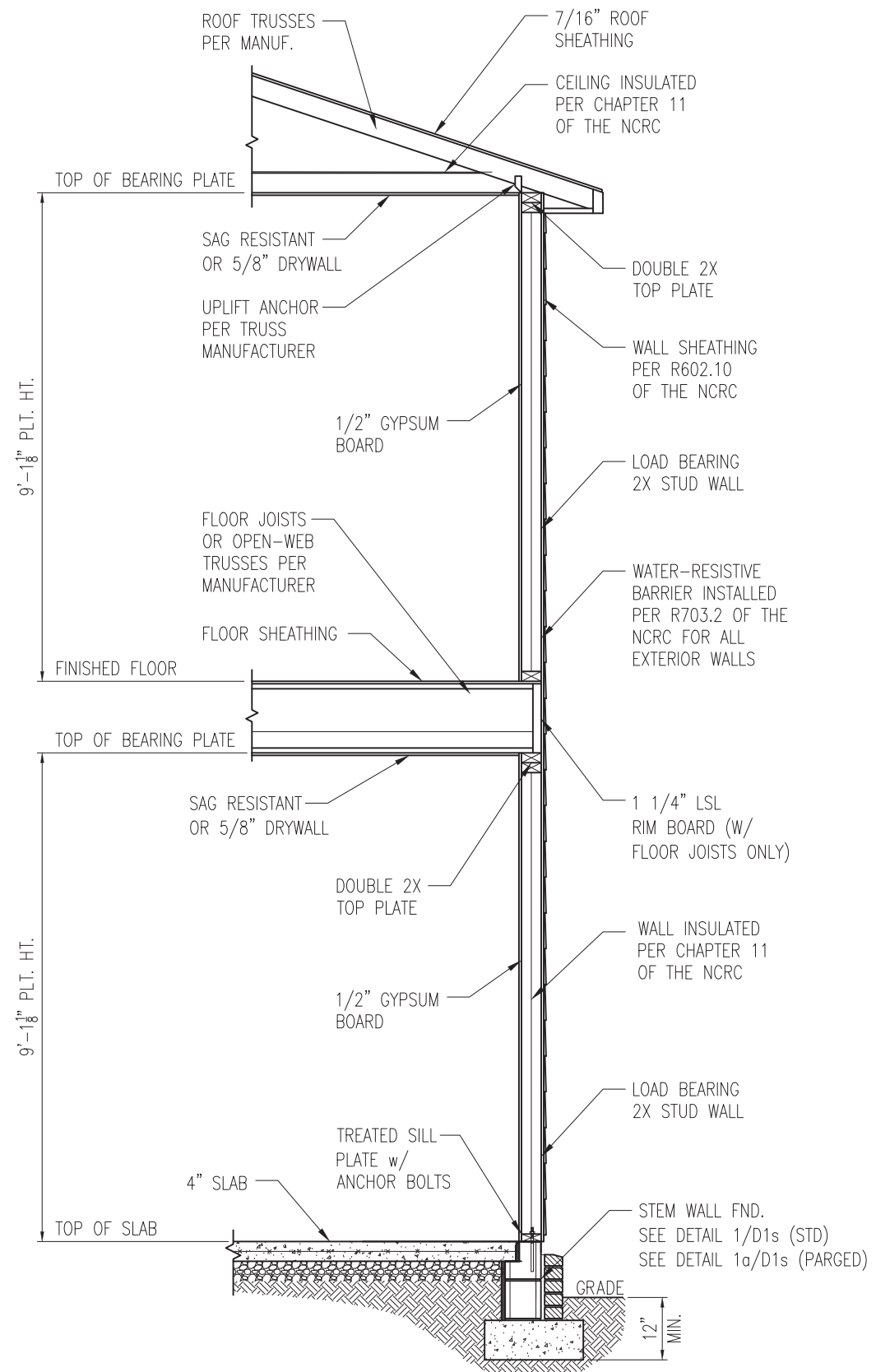

2 TYP. EXTERIOR LOAD BEARING WALL SECTION
 D4s 3/4" = 1'-0" -SIMILAR w/ BRICK AND STONE
 -BRICK TIES SPACED @ 16" O.C. HORIZ. & 24" O.C. VERT.
 -MIN. 3/16" WEEP HOLES @ 33" O.C.

- NOTES:
1. REFER TO GENERAL NOTES & SPECIFICATIONS ON SHEET CS2 FOR ADDITIONAL INFORMATION.
 2. PROVIDE 6 MIL VAPOR BARRIER UNDER ALL SLABS-ON-GRADE.
 3. SEE ARCH. DWGS. FOR ALL TOP OF THE SLAB ELEVATIONS, SLOPES AND DEPRESSIONS.



STRUCTURAL MEMBERS ONLY

SUMMIT
 ENGINEERING LABORATORY TESTING
 3070 HAMMOND BUSINESS PLACE,
 SUITE 171, RALEIGH, NC 27603
 OFFICE: 919.380.9991
 FAX: 919.380.9993
 WWW.SUMMIT-COMPANIES.COM

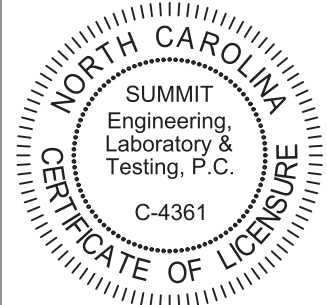

PROJECT
Standard Details
Stemwall Details
 CLIENT
Smith Douglas Homes
 110 Village Trail, Suite 215
 Woodstock, GA 30188

CURRENT DRAWING
 DATE: 2/18/20
 SCALE: NTS
 PROJECT #: 3832
 DRAWN BY: LBV
 CHECKED BY: WAJ

ORIGINAL DRAWING
 NO. DATE PROJECT #
 0 1/7/16 3832

REFER TO COVER SHEET FOR A COMPLETE LIST OF REVISIONS

SHEET
D4s

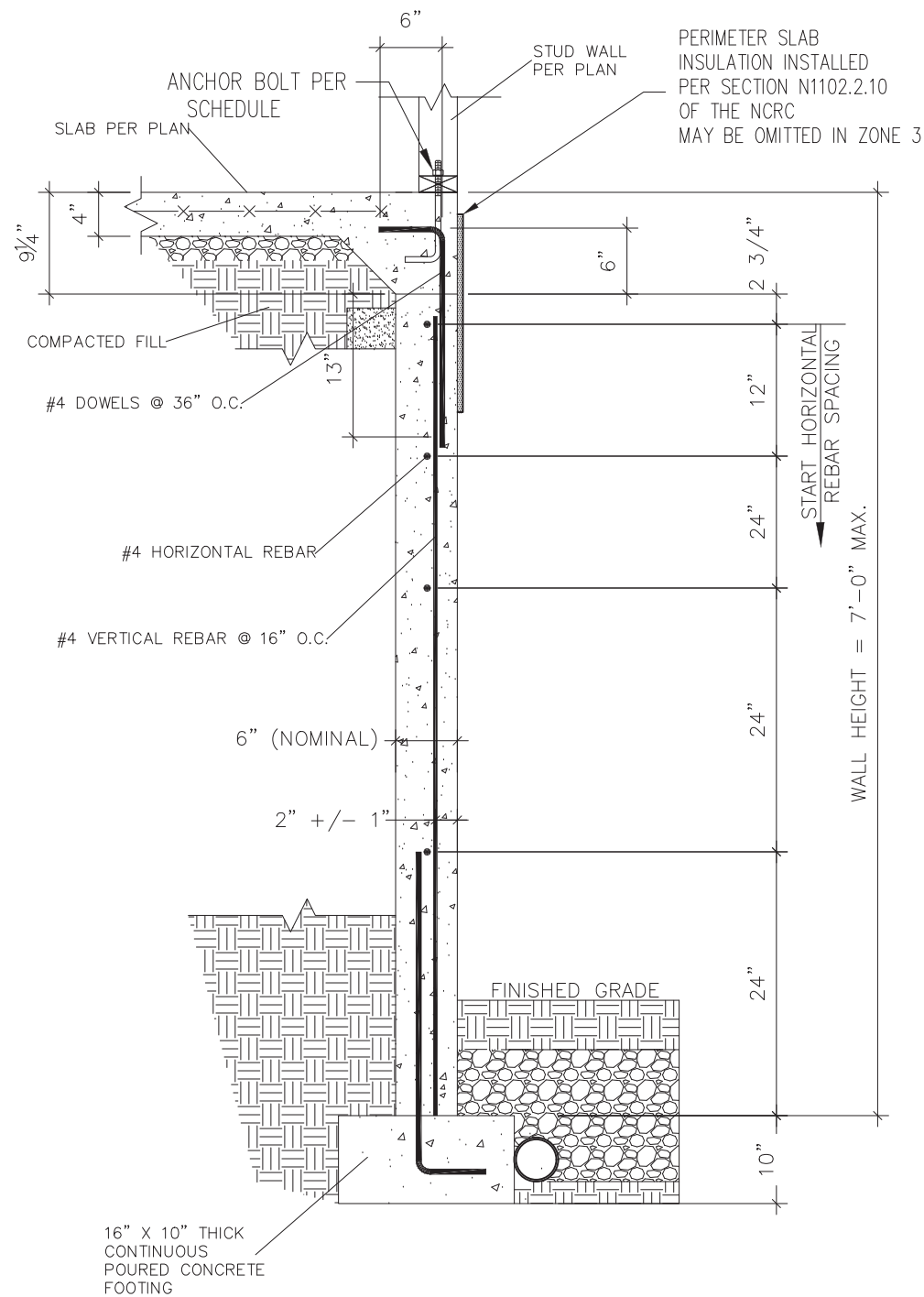

1 SUBWALL FOUNDATION
 D5s 3/4" = 1'-0"

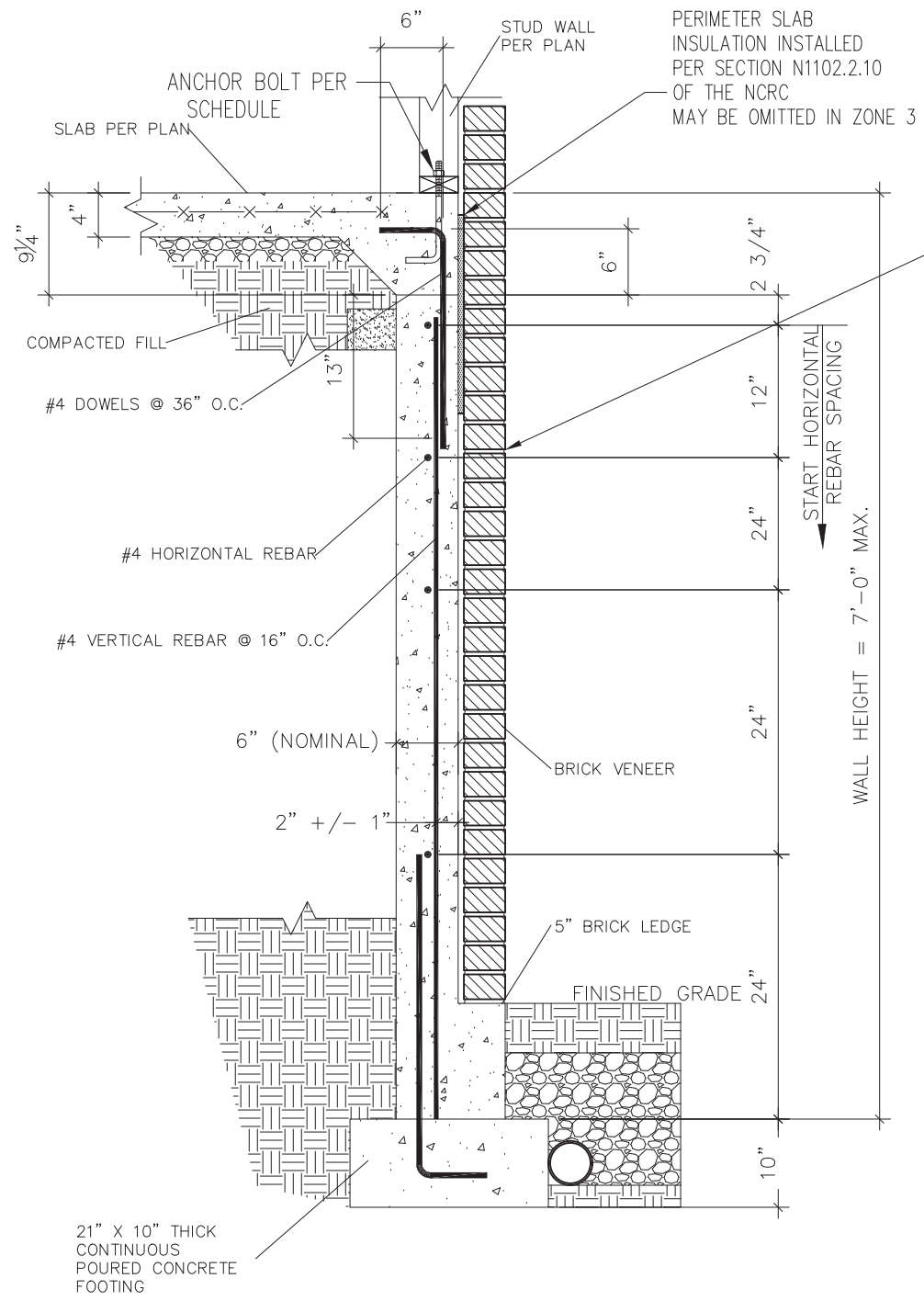

2 SUBWALL FOUNDATION W/ BRICK VENEER
 D5s 3/4" = 1'-0"

PROVIDE LADDER WIRE OR METAL TIES, INSTALLED PER R608.1.2 OF THE 2012 NCRC, AND FULLY GROUT BETWEEN BRICK AND CONCRETE.



STRUCTURAL MEMBERS ONLY

SUMMIT
 ENGINEERING LABORATORY TESTING
 3070 HAMMOND BUSINESS PLACE,
 SUITE 171, RALEIGH, NC 27603
 OFFICE: 919.380.9991
 FAX: 919.380.9993
 WWW.SUMMIT-COMPANIES.COM

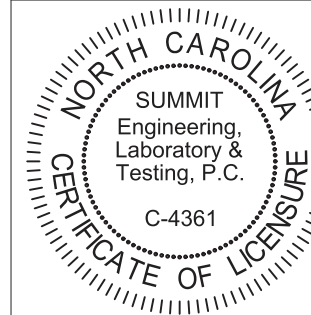

PROJECT
Standard Details
Stemwall Details
 CLIENT
 Smith Douglas Homes
 110 Village Trail, Suite 215
 Woodstock, GA 30188

CURRENT DRAWING
 DATE: 2/18/20
 SCALE: NTS
 PROJECT #: 3832
 DRAWN BY: LBV
 CHECKED BY: WAJ

ORIGINAL DRAWING
 NO. DATE PROJECT #
 0 1/7/16 3832

REFER TO COVER SHEET FOR A COMPLETE LIST OF REVISIONS

SHEET

D5s

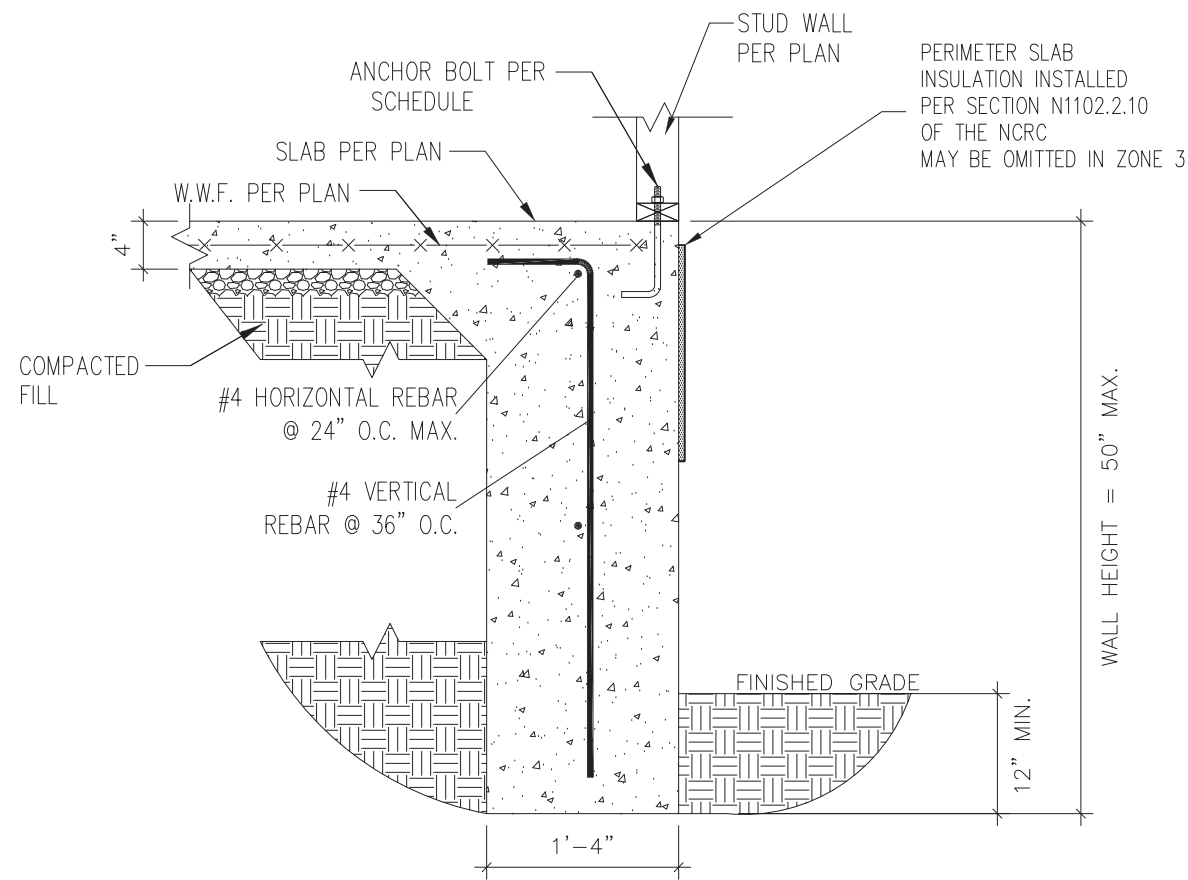

1 TURNDOWN FOUNDATION
 D6s 3/4" = 1'-0"

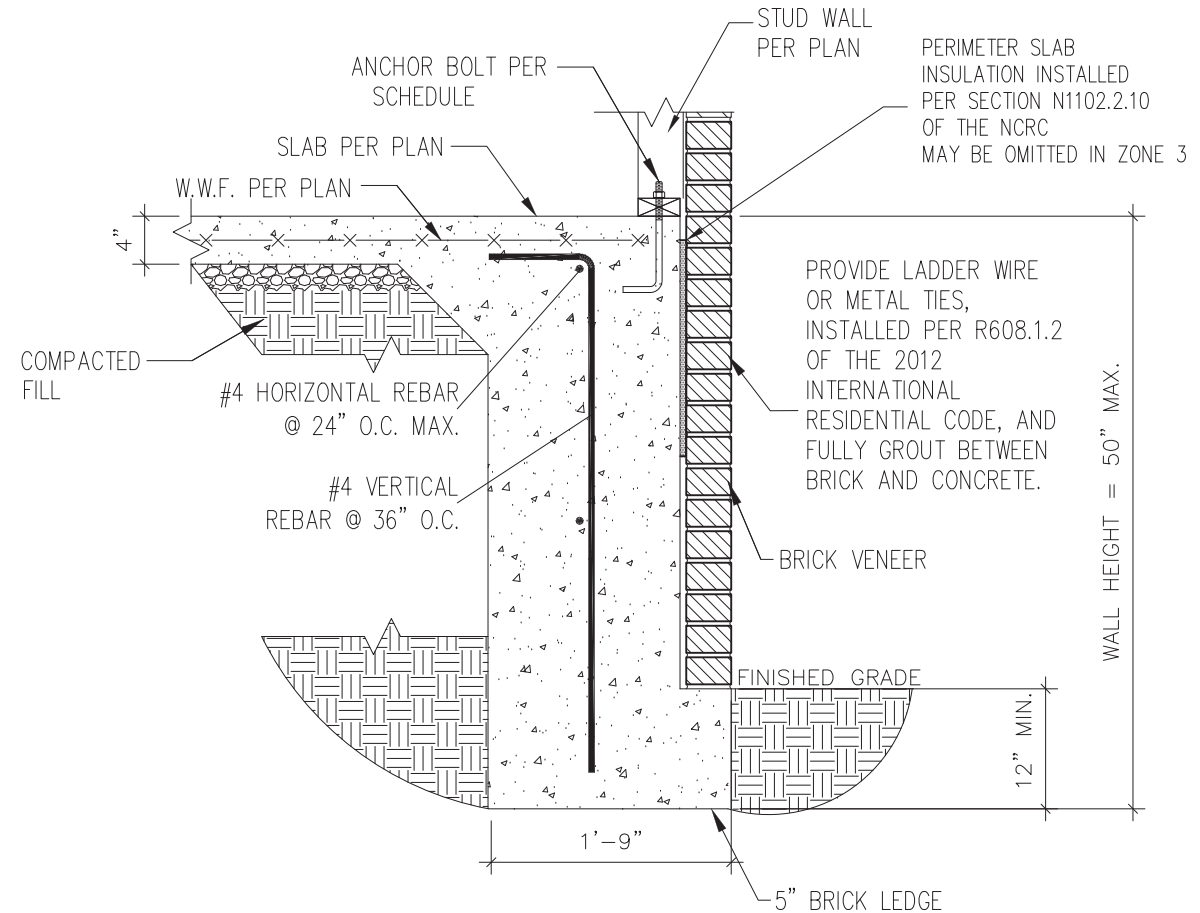

2 TURNDOWN FOUNDATION W/ BRICK VENEER
 D6s 3/4" = 1'-0"

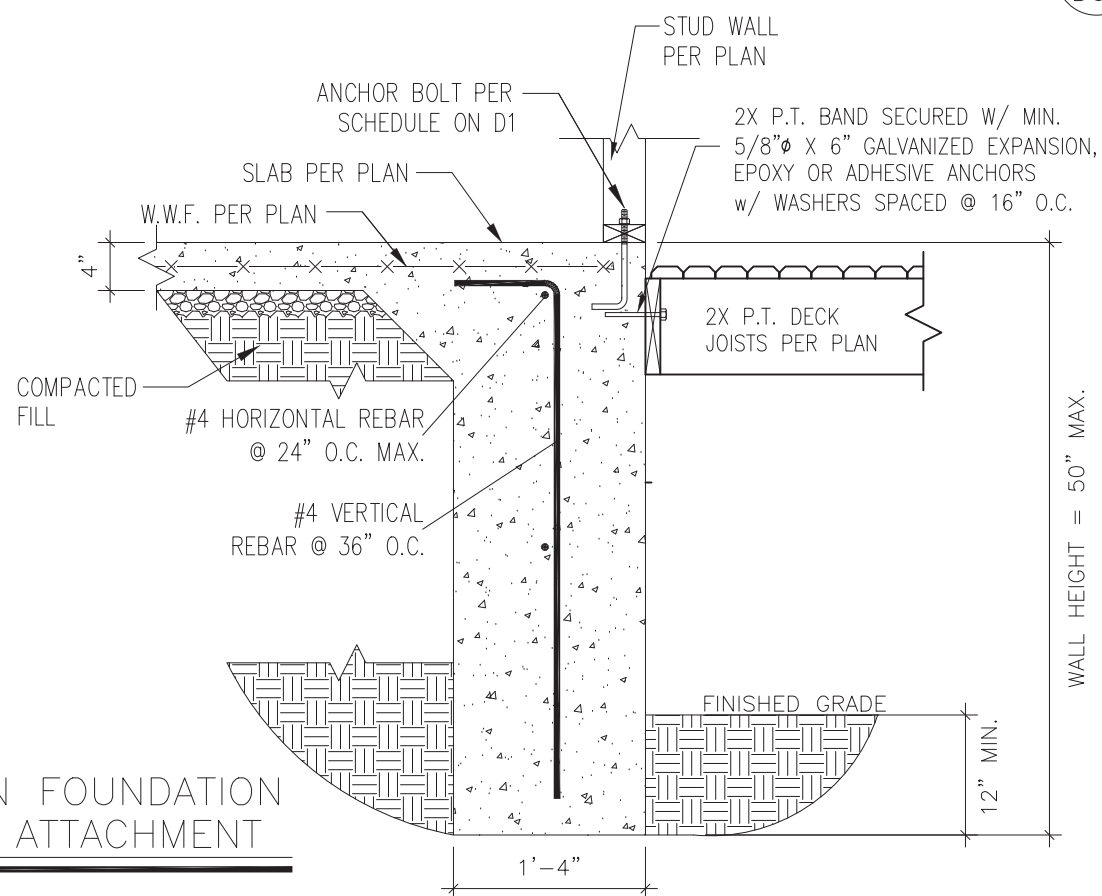

3 TURNDOWN FOUNDATION W/ DECK ATTACHMENT
 D6s 3/4" = 1'-0"



STRUCTURAL MEMBERS ONLY

SUMMIT
 ENGINEERING LABORATORY TESTING
 3070 HAMMOND BUSINESS PLACE,
 SUITE 171, RALEIGH, NC 27603
 OFFICE: 919.380.9991
 FAX: 919.380.9993
 WWW.SUMMIT-COMPANIES.COM

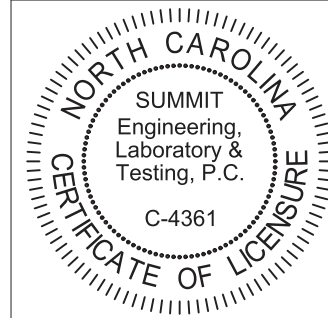

PROJECT
Standard Details
Stemwall Details
 CLIENT
Smith Douglas Homes
 110 Village Trail, Suite 215
 Woodstock, GA 30188

CURRENT DRAWING
 DATE: 2/18/20
 SCALE: NTS
 PROJECT #: 3832
 DRAWN BY: LBV
 CHECKED BY: WAJ

ORIGINAL DRAWING
 NO. DATE PROJECT #
 0 1/7/16 3832

REFER TO COVER SHEET FOR A COMPLETE LIST OF REVISIONS

SHEET
D6s

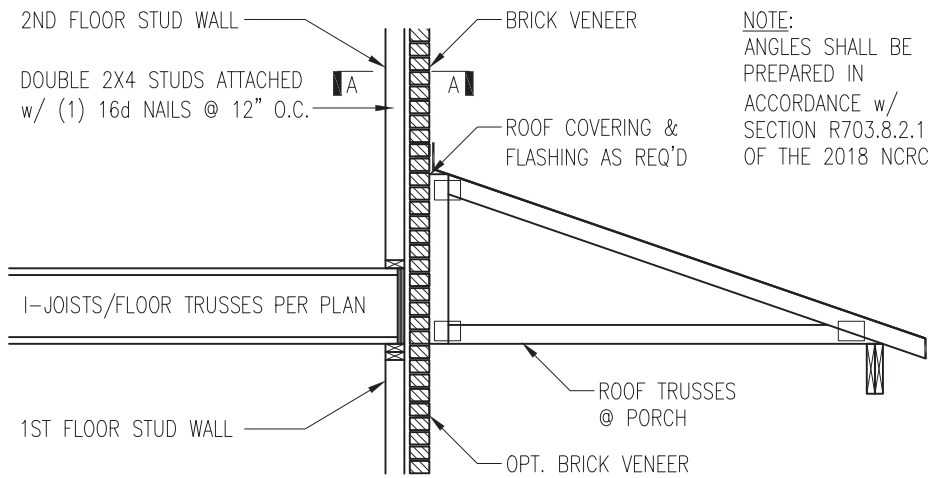

NOTE:
ANGLES SHALL BE
PREPARED IN
ACCORDANCE W/
SECTION R703.8.2.1
OF THE 2018 NCR

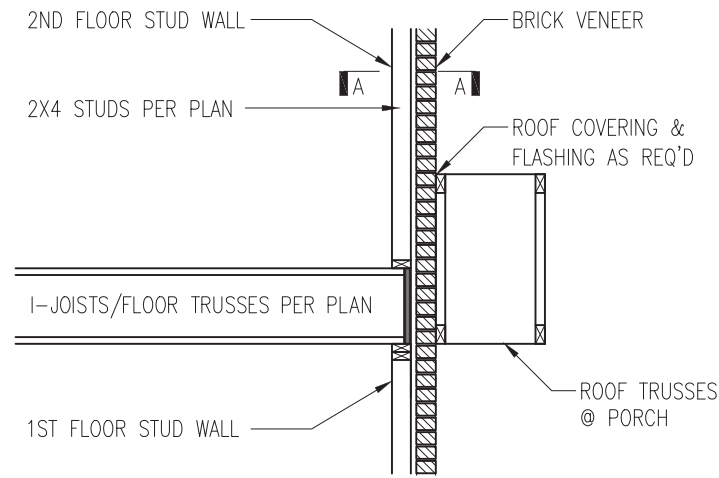

TRUSSES PERPENDICULAR TO STUD WALL

TRUSSES PARALLEL TO STUD WALL
w/ CONTINUOUS BRICK VENEER

1 BRICK SUPPORT ABOVE STORAGE/PORCH ROOF DETAIL
D5f NTS

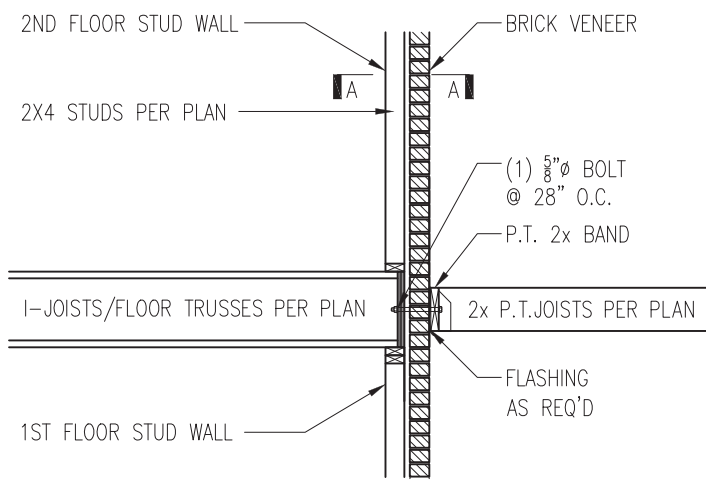

3 BALCONY JOIST ATTACHMENT
D5f NTS

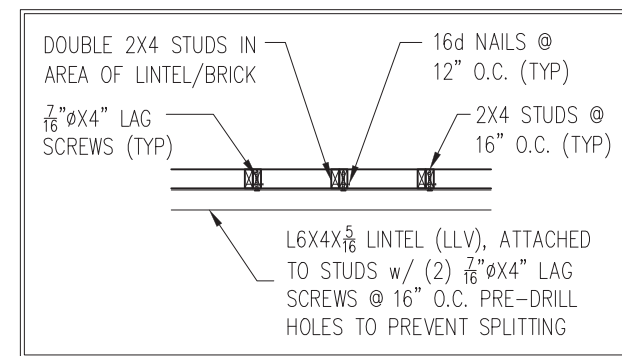

SECTION A-A
NTS

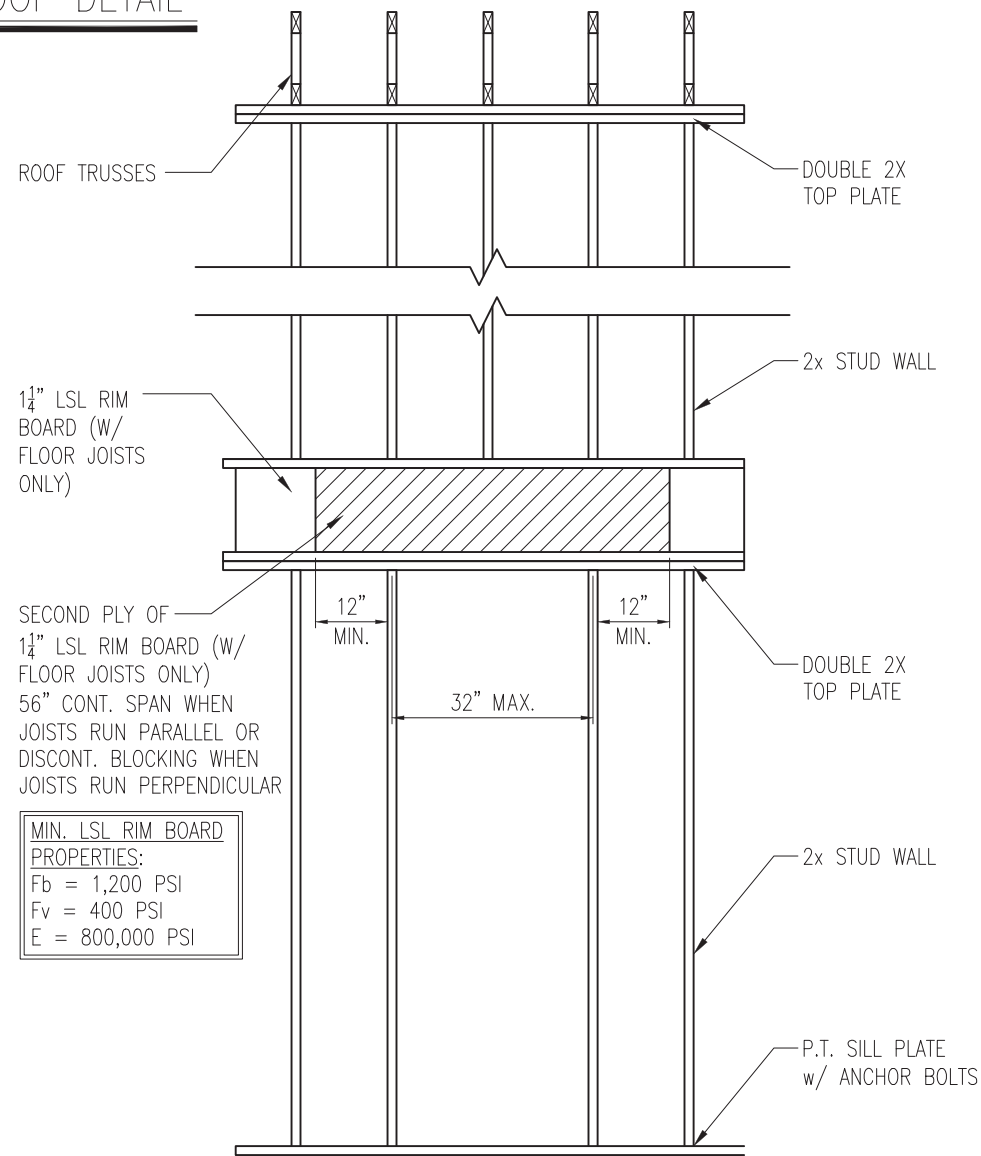

SECOND PLY OF
1 1/4\"/>

MIN. LSL RIM BOARD
PROPERTIES:
Fb = 1,200 PSI
Fv = 400 PSI
E = 800,000 PSI

4 TYP. RANGE VENT FRAMING
D5f VENTED TO EXTERIOR WALL

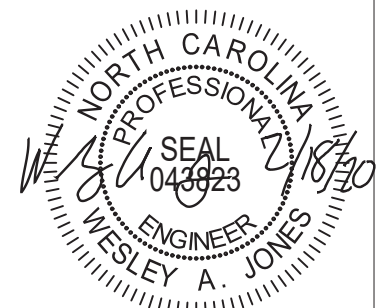

STRUCTURAL MEMBERS ONLY

SUMMIT
ENGINEERING LABORATORY TESTING
3070 HAMMOND BUSINESS PLACE,
SUITE 171, RALEIGH, NC 27603
OFFICE: 919.380.9991
FAX: 919.380.9993
WWW.SUMMIT-COMPANIES.COM

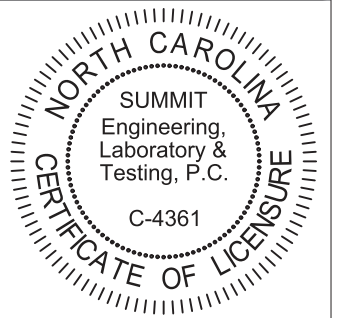

PROJECT
Standard Details
Framing Details
CLIENT
Smith Douglas Homes
110 Village Trail, Suite 215
Woodstock, GA 30188

CURRENT DRAWING
DATE: 2/18/20
SCALE: NTS
PROJECT #: 3832
DRAWN BY: LBV
CHECKED BY: WAJ

ORIGINAL DRAWING
NO. DATE PROJECT #
0 1/7/16 3832

REFER TO COVER SHEET FOR A COMPLETE LIST OF REVISIONS

SHEET
D5f

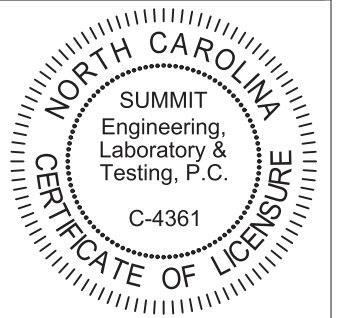
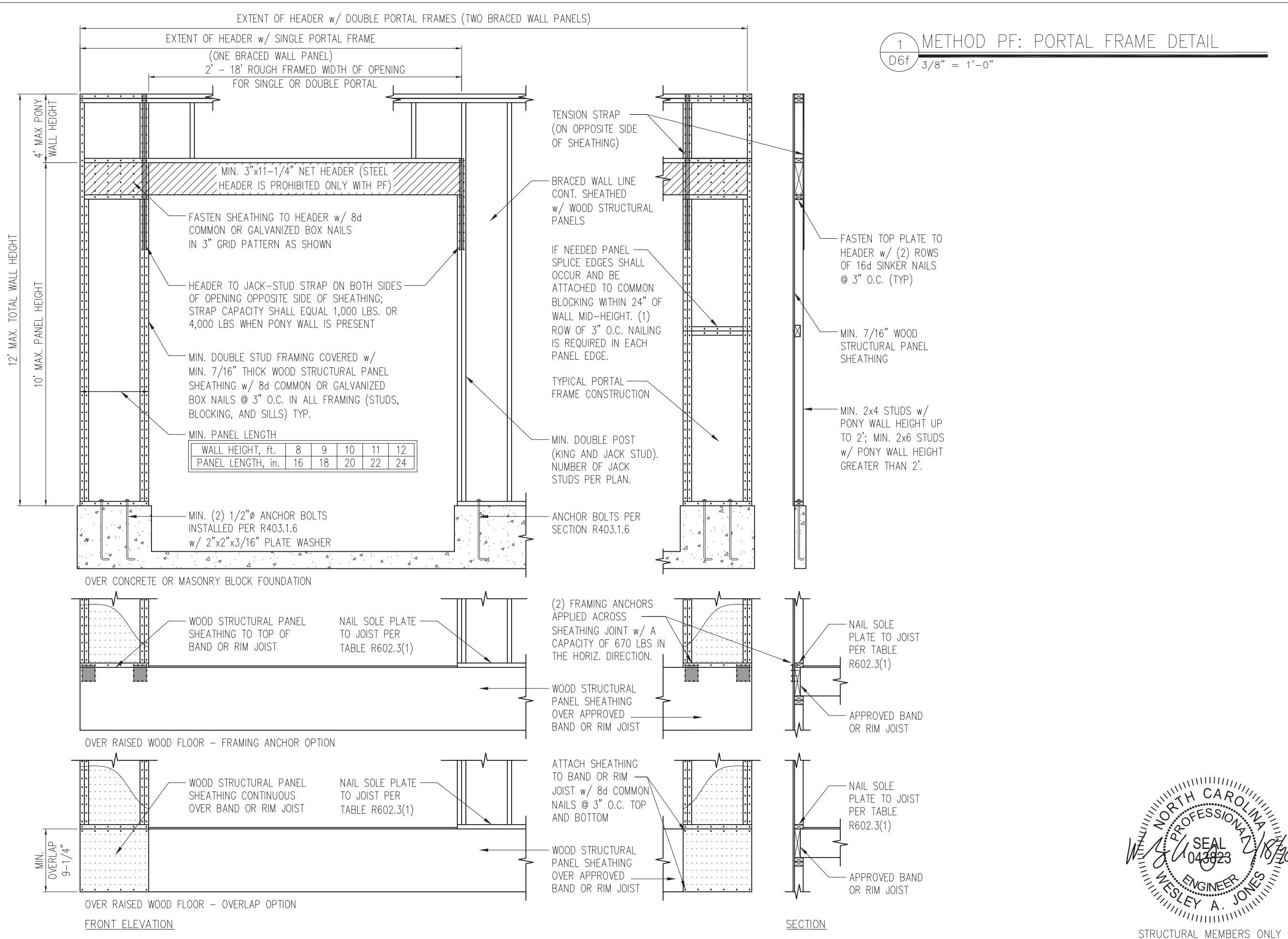

PROJECT
Standard Details
Framing Details - Bracing

CLIENT
Smith Douglas Homes
110 Village Trail, Suite 215
Woodstock, GA 30188

CURRENT DRAWING
DATE: 2/18/20
SCALE: NTS
PROJECT #: 3832
DRAWN BY: LBV
CHECKED BY: WAJ

ORIGINAL DRAWING
NO. DATE PROJECT #
0 1/7/16 3832

REFER TO COVER SHEET FOR A COMPLETE LIST OF REVISIONS



STRUCTURAL MEMBERS ONLY

SHEET
D6f

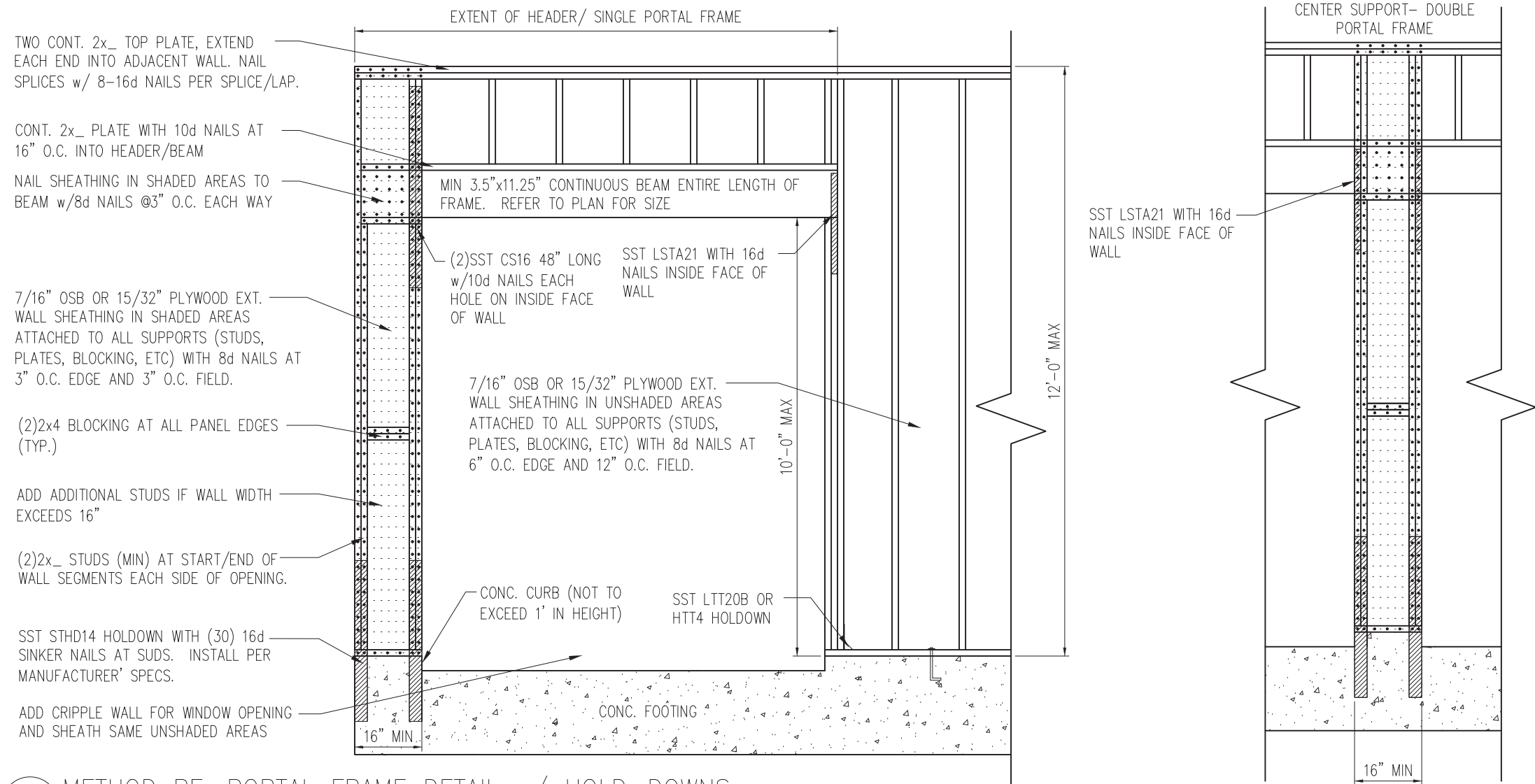

1 METHOD PF: PORTAL FRAME DETAIL w/ HOLD-DOWNS
 D7f 3/4" = 1'-0"

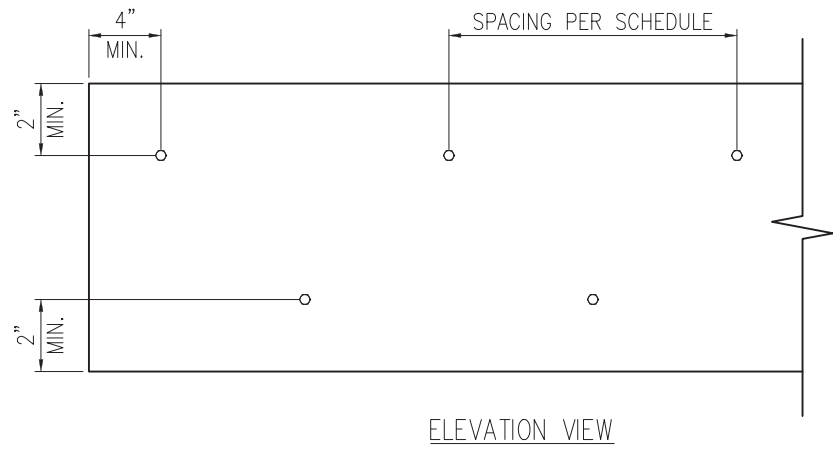

2 MULTI-PLY BEAM CONNECTION DETAIL
 D7f N.T.S

MINIMUM FASTENING REQUIREMENTS FOR TOP- AND SIDE-LOADED MEMBERS

| FASTENER TYPE | LVL DEPTH | 3 1/2" WIDE | | 5 1/4" WIDE | | 7" WIDE | |
|--|------------------|-------------------|------------------------|-------------------|------------------------|------------------------|--------------|
| | | 2-Ply 1 3/4" | 3-Ply 1 3/4" | 1 3/4" + 3 1/2" | 4-Ply 1 3/4" | 2-Ply 1 3/4" + 3 1/2" | 2-Ply 3 1/2" |
| 10d (0.128" x 3") Nails | 7 1/4" ≤ d < 14" | 3 rows @ 12" o.c. | 3 rows @ 12" o.c. (ES) | 3 rows @ 12" o.c. | - | 3 rows @ 12" o.c. (ES) | - |
| | d ≥ 14" | 4 rows @ 12" o.c. | 4 rows @ 12" o.c. (ES) | 4 rows @ 12" o.c. | - | 4 rows @ 12" o.c. (ES) | - |
| 16d (0.162" x 3 1/2") Nails | 7 1/4" ≤ d < 14" | 2 rows @ 12" o.c. | 2 rows @ 12" o.c. (ES) | 2 rows @ 12" o.c. | - | 2 rows @ 12" o.c. (ES) | - |
| | d ≥ 14" | 3 rows @ 12" o.c. | 3 rows @ 12" o.c. (ES) | 3 rows @ 12" o.c. | - | 3 rows @ 12" o.c. (ES) | - |
| 1/2" Through Bolts | d ≥ 7 1/4" | 2 rows @ 24" o.c. | 2 rows @ 24" o.c. | | 2 rows @ 24" o.c. | | - |
| SDS 1/4" x 3 1/2", WS35, 3 3/8" TrussLok | | 2 rows @ 24" o.c. | 2 rows @ 24" o.c. (ES) | 2 rows @ 24" o.c. | - | 2 rows @ 24" o.c. (ES) | - |
| SDS 1/4" x 6", WS6 | | - | - | - | 2 rows @ 24" o.c. (ES) | | - |
| 5" TrussLok | | - | 2 rows @ 24" o.c. | | - | | - |
| 6 3/4" TrussLok | | - | - | - | 2 rows @ 24" o.c. | | - |

NOTES:

- All fasteners must meet the minimum requirements in the table above. Side-loaded multiple-ply members must meet the minimum fastening and side-loading capacity requirements given on page 48.
- Minimum fastening requirements for depths less than 7 1/4" require special consideration. Please contact your technical representative.
- Three general rules for staggering or offsetting for a certain fastener schedule:
 - If staggering or offsetting is not referenced, then none is required;
 - If staggering is referenced, then fasteners installed in adjacent rows on the front side are to be staggered up to one-half the o.c. spacing, but maintaining the fastener clearances above; and
 - If "ES" is referenced, then the fastener schedule must be repeated on each side, with the fasteners on the back side offset up to one-half the o.c. spacing of the front side (whether or not it is staggered).

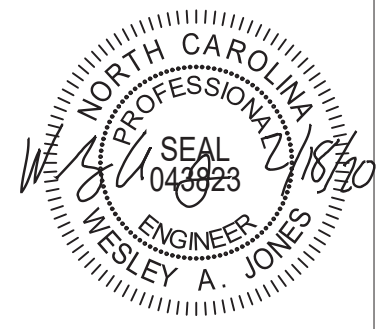

STRUCTURAL MEMBERS ONLY

SUMMIT
 ENGINEERING LABORATORY TESTING
 3070 HAMMOND BUSINESS PLACE,
 SUITE 171, RALEIGH, NC 27603
 OFFICE: 919.380.9991
 FAX: 919.380.9993
 WWW.SUMMIT-COMPANIES.COM

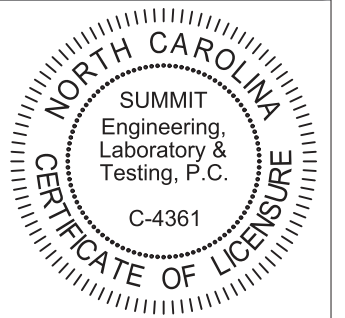

PROJECT
 Standard Details
 Framing Details - Bracing
 CLIENT
 Smith Douglas Homes
 110 Village Trail, Suite 215
 Woodstock, GA 30188

CURRENT DRAWING
 DATE: 2/18/20
 SCALE: NTS
 PROJECT #: 3832
 DRAWN BY: LBV
 CHECKED BY: WAJ
 ORIGINAL DRAWING
 NO. DATE PROJECT #
 0 1/7/16 3832

REFER TO COVER SHEET FOR A COMPLETE LIST OF REVISIONS

SHEET
D7f

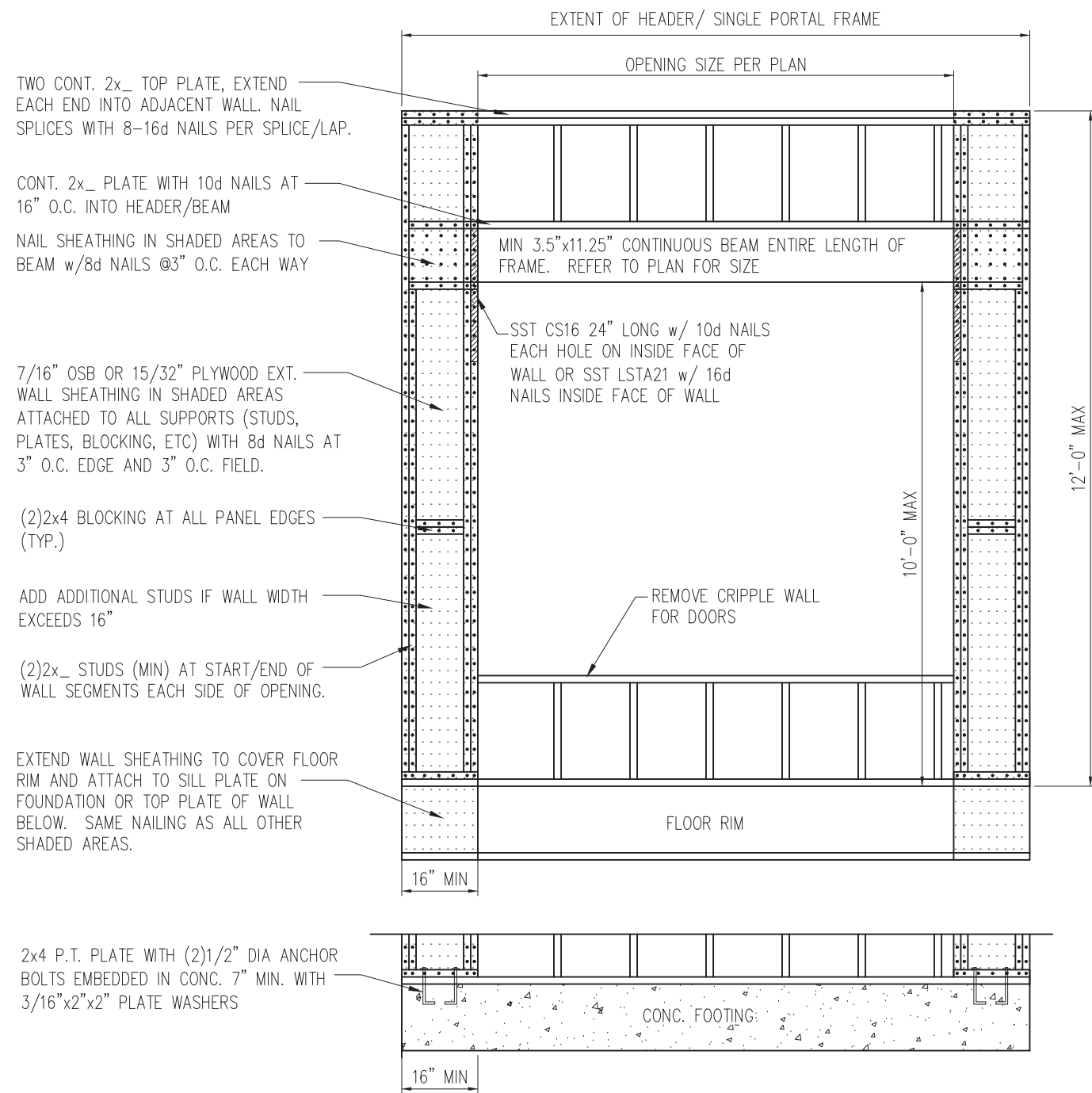

TWO CONT. 2x_ TOP PLATE, EXTEND EACH END INTO ADJACENT WALL. NAIL SPLICES WITH 8-16d NAILS PER SPLICE/LAP.

CONT. 2x_ PLATE WITH 10d NAILS AT 16\" O.C. INTO HEADER/BEAM

NAIL SHEATHING IN SHADED AREAS TO BEAM w/8d NAILS @3\" O.C. EACH WAY

7/16\" OSB OR 15/32\" PLYWOOD EXT. WALL SHEATHING IN SHADED AREAS ATTACHED TO ALL SUPPORTS (STUDS, PLATES, BLOCKING, ETC) WITH 8d NAILS AT 3\" O.C. EDGE AND 3\" O.C. FIELD.

(2)2x4 BLOCKING AT ALL PANEL EDGES (TYP.)

ADD ADDITIONAL STUDS IF WALL WIDTH EXCEEDS 16\"

(2)2x_ STUDS (MIN) AT START/END OF WALL SEGMENTS EACH SIDE OF OPENING.

EXTEND WALL SHEATHING TO COVER FLOOR RIM AND ATTACH TO SILL PLATE ON FOUNDATION OR TOP PLATE OF WALL BELOW. SAME NAILING AS ALL OTHER SHADED AREAS.

2x4 P.T. PLATE WITH (2)1/2\" DIA ANCHOR BOLTS EMBEDDED IN CONC. 7\" MIN. WITH 3/16\"x2\"x2\" PLATE WASHERS

1 METHOD PF: PORTAL FRAME DETAIL
D8f 3/4\" = 1'-0\" OPENINGS UNDER 8'-0\"

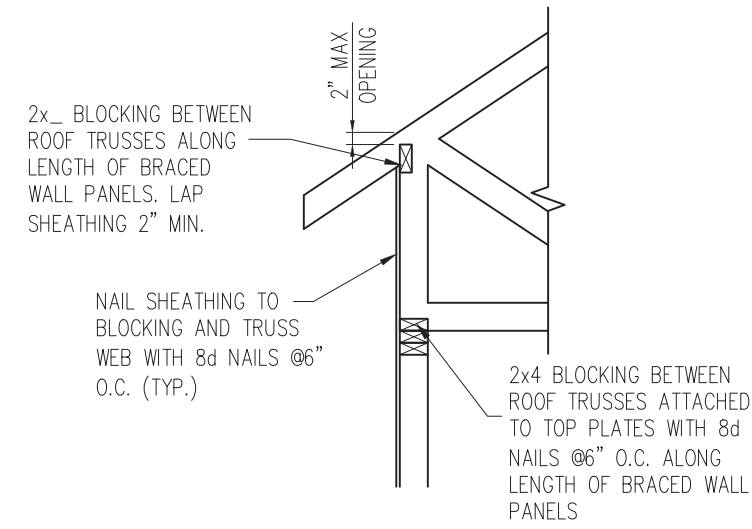

HEEL HEIGHT GREATER THAN 15.25\"

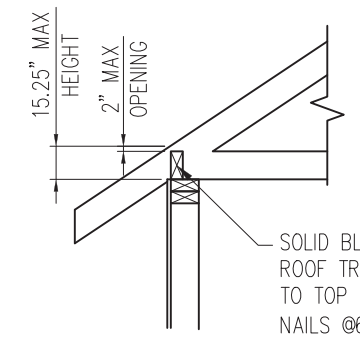

*BLOCKING IS NOT REQUIRED WITH HEEL HEIGHTS LESS THAN 9.25\"

HEEL HEIGHT LESS THAN 15.25\" *

2 TYP. WALL PANEL TO ROOF TRUSS CONNECTION
D8f 1\" = 1'-0\"



STRUCTURAL MEMBERS ONLY

SUMMIT
ENGINEERING LABORATORY TESTING
3070 HAMMOND BUSINESS PLACE,
SUITE 171, RALEIGH, NC 27603
OFFICE: 919.380.9991
FAX: 919.380.9993
WWW.SUMMIT-COMPANIES.COM

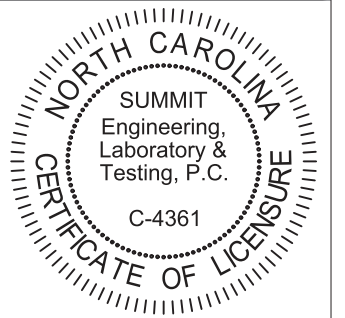

PROJECT
Standard Details - Bracing
Framing Details - Bracing
CLIENT
Smith Douglas Homes
110 Village Trail, Suite 215
Woodstock, GA 30188

CURRENT DRAWING
DATE: 2/18/20
SCALE: NTS
PROJECT #: 3832
DRAWN BY: LBV
CHECKED BY: WAJ

ORIGINAL DRAWING
NO. DATE PROJECT #
0 1/7/16 3832

REFER TO COVER SHEET FOR A COMPLETE LIST OF REVISIONS

SHEET
D8f

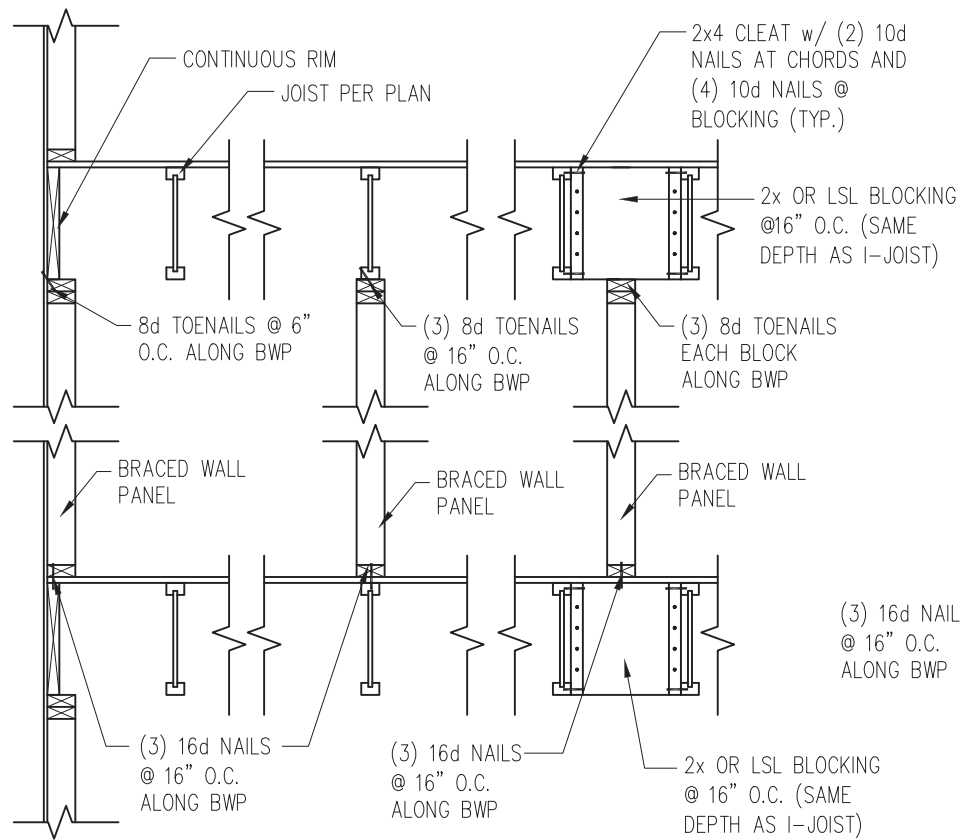

JOISTS PARALLEL TO BRACED WALLS

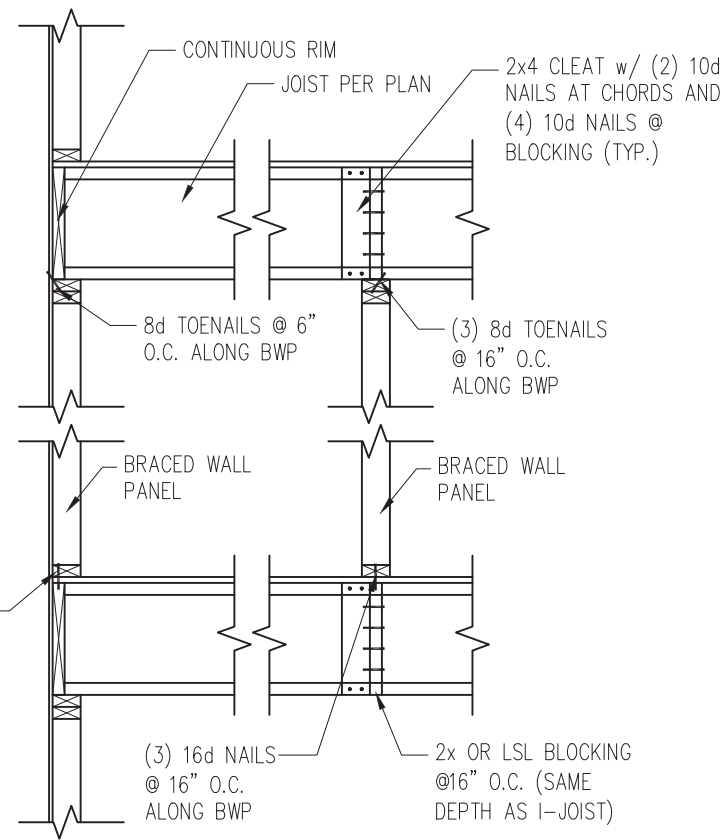

JOISTS PERPENDICULAR TO BRACED WALLS

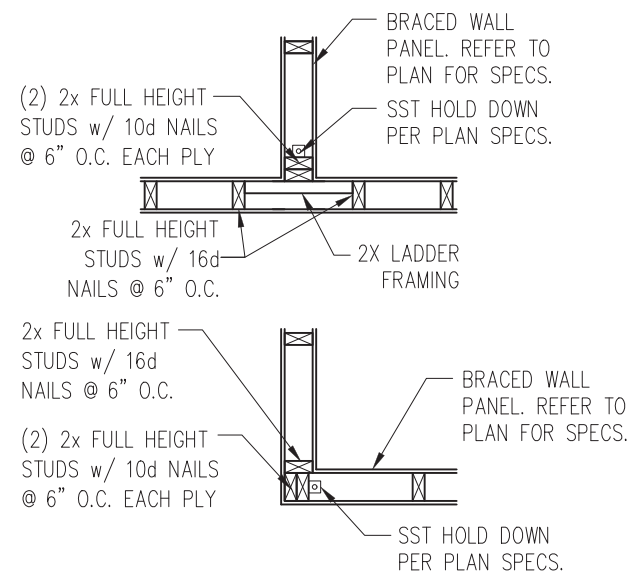

4 TYP. HOLD DOWN DETAIL
D9f 1" = 1'-0"

1 TYP. WALL PANEL TO FLOOR/CEILING CONNECTION
D9f 1" = 1'-0"

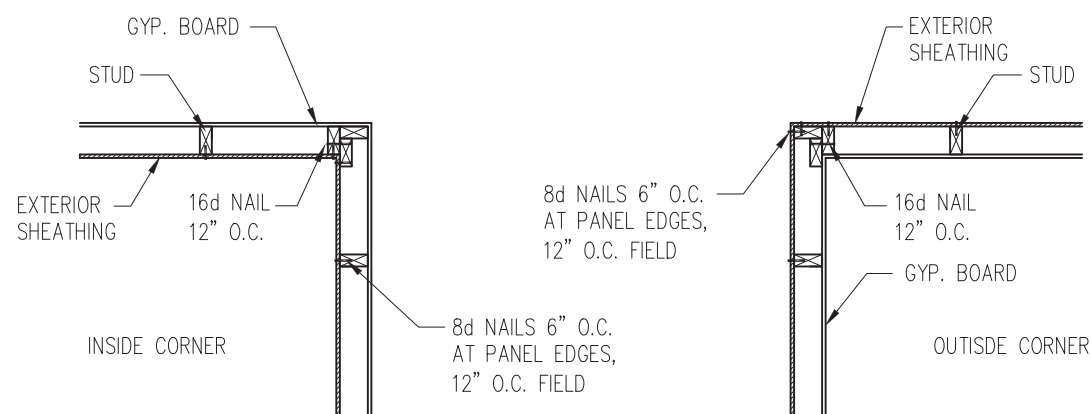

2 TYP. EXTERIOR CORNER FRAMING
D9f 1" = 1'-0"

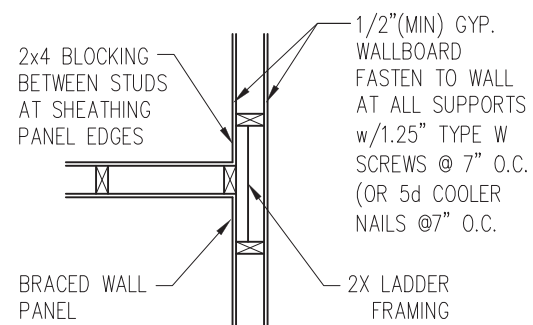

3 INTERIOR 3-STUD WALL INTERSECTION
D9f 1" = 1'-0"



STRUCTURAL MEMBERS ONLY

SUMMIT
ENGINEERING LABORATORY TESTING
3070 HAMMOND BUSINESS PLACE,
SUITE 171, RALEIGH, NC 27603
OFFICE: 919.380.9991
FAX: 919.380.9993
WWW.SUMMIT-COMPANIES.COM

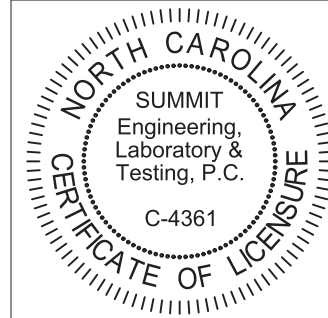

PROJECT
Standard Details
Framing Details - Bracing
CLIENT
Smith Douglas Homes
110 Village Trail, Suite 215
Woodstock, GA 30188

CURRENT DRAWING
DATE: 2/18/20
SCALE: NTS
PROJECT #: 3832
DRAWN BY: LBV
CHECKED BY: WAJ

ORIGINAL DRAWING
NO. DATE PROJECT #
0 1/7/16 3832

REFER TO COVER SHEET FOR A COMPLETE LIST OF REVISIONS

SHEET
D9f

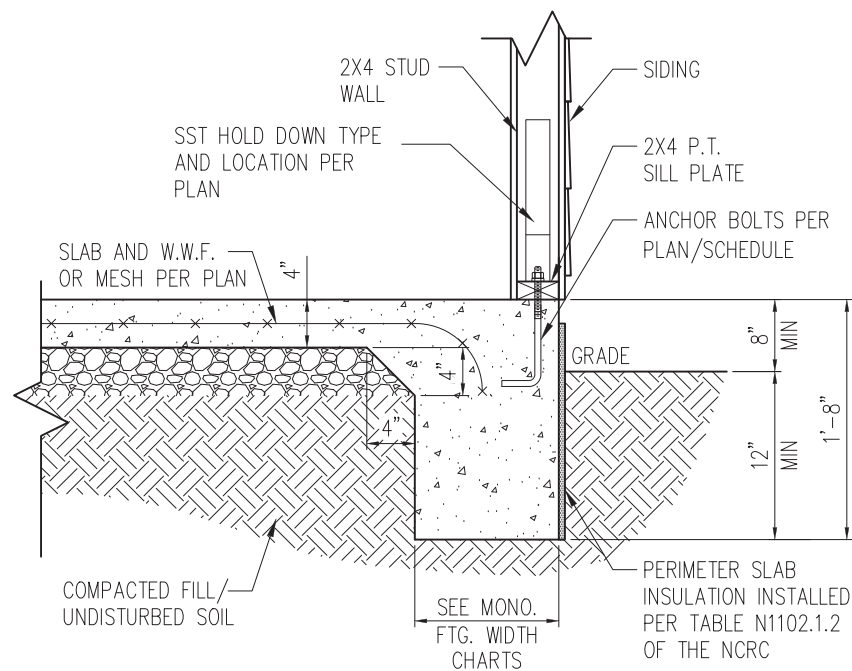

1 SLAB DETAIL w/ HOLD-DOWN
 D10f 3/4" = 1'-0"

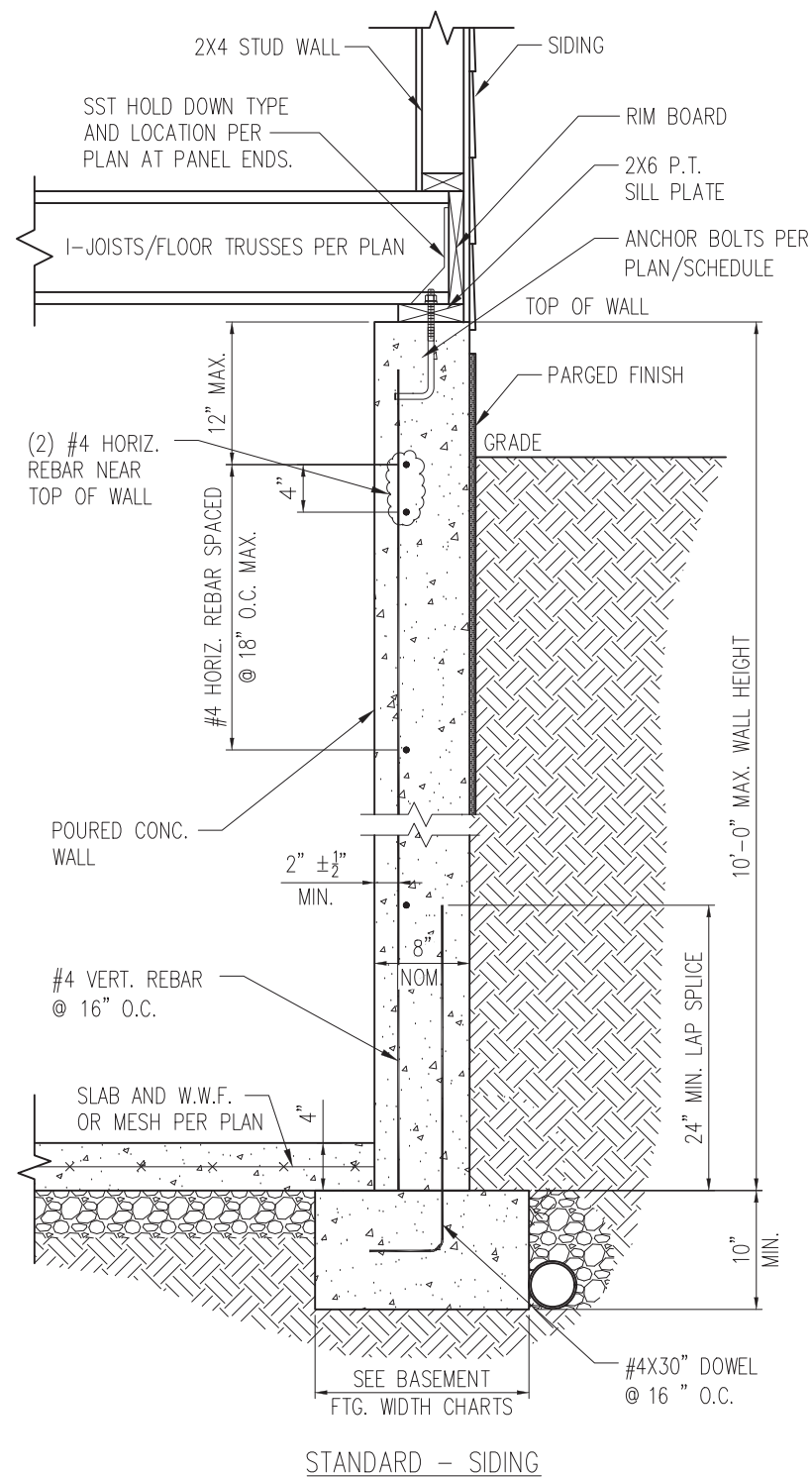

2 BASEMENT FOUNDATION WALL DETAIL W/ HOLD-DOWN
 D10f 3/4" = 1'-0"



STRUCTURAL MEMBERS ONLY

SUMMIT
 ENGINEERING LABORATORY TESTING
 3070 HAMMOND BUSINESS PLACE,
 SUITE 171, RALEIGH, NC 27603
 OFFICE: 919.380.9991
 FAX: 919.380.9993
 WWW.SUMMIT-COMPANIES.COM

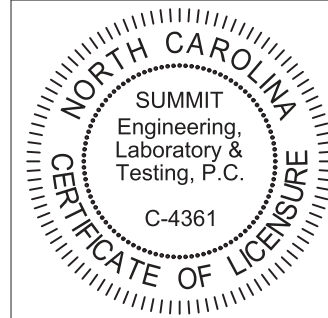

PROJECT
Standard Details
Framing Details - Bracing
 CLIENT
Smith Douglas Homes
 110 Village Trail, Suite 215
 Woodstock, GA 30188

CURRENT DRAWING
 DATE: 2/18/20
 SCALE: NTS
 PROJECT #: 3832
 DRAWN BY: LBV
 CHECKED BY: WAJ

| NO. | DATE | PROJECT # |
|-----|--------|-----------|
| 0 | 1/7/16 | 3832 |

REFER TO COVER SHEET FOR A COMPLETE LIST OF REVISIONS

SHEET
D10f