



VININGS

CANE MILL ESTATES
LOT 6



PLAN ID: 022020

110 VILLAGE TRAIL SUITE 215
WOODSTOCK, GA. 30188

| DRAWING INDEX | |
|---------------|-----------------------------|
| A0.0 | COVER SHEET |
| A1.1 | FRONT ELEVATIONS |
| A2.1 | SIDE & REAR ELEVATIONS |
| A3.1 | SLAB FOUNDATIONS |
| A5.1 | FIRST FLOOR PLANS & OPTIONS |
| A6.1 | ROOF PLANS |
| A7.2 | ELECTRICAL PLANS |

| AREA TABULATION | |
|--------------------------|------|
| FIRST FLOOR | 1819 |
| TOTAL | 1819 |
| GARAGE | 675 |
| FRONT PORCH (COVERED) | 137 |
| REAR PATIO | 9 |

| PLAN REVISIONS | | | |
|----------------|----|---|---------------------------------------|
| DATE | BY | REVISION | PAGE # |
| 9/24/2018 | MM | Added optional unfinished storage and finished Bonus Room. Removed wood burning F.P. | ALL |
| 1/10/2019 | MM | Added optional unfinished basement | A4.1 |
| 1/18/2019 | AW | Prototype walk revisions - see revision sheet for changes | A3.1, A5.1, A7.2 |
| 3/27/2019 | MM | Added callout for detail 3/D5.1 for A massing | A1.1-A1.9.1 |
| 8/2/2019 | AW | PCR # 3105 Removed column at Foyer/Dining | A5.1, A5.1.1, A5.1.2, A7.2, A8.1 |
| 10/11/2019 | AW | PCR #3301 Relocated door for optional 2nd flr to the top of the stairs (see revision sht.) | A5.1.1, A5.3, A5.4.1, A7.2, A7.3 |
| 12/18/2019 | AW | PCR #3464 Remove outlet on knee wall behind kitchen sink and reduce overhang at end of peninsula to 6" per code | A5.1-A5.1.2, A7.2 |
| 2/19/2020 | AW | PCR #3621 Remove hdr. between Dining & Lndry Hall and reduce length of wall next to refrig. 12" | A5.1-A5.1.2, A7.2, A8.1 |
| 2/20/2020 | AW | Added new Obath configuration to allow for separate tub and shower and created basement plan only Obath options | A3.1, A3.1.1, A5.1-A5.1.2, A7.2, A8.1 |
| 11/1/2020 | MM | PCR #4201 Relocated pendant lights | A7.2 |
| 5/1/2021 | MM | Removed unfinished 2nd flr option | A5.3, A7.3 |
| | | | |

GOVERNMENTAL CODES & STANDARDS
HOME TO BE BUILT TO CONFORM TO ALL APPLICABLE LOCAL CODES, PRACTICES AND STANDARDS

BUILDING CODE ANALYSIS / DESIGN CRITERIA
HOME TO BE BUILT TO MEET OR EXCEED ALL LOCAL CODES AND DESIGN CRITERIA

CANE MILL ESTATES LOT 6

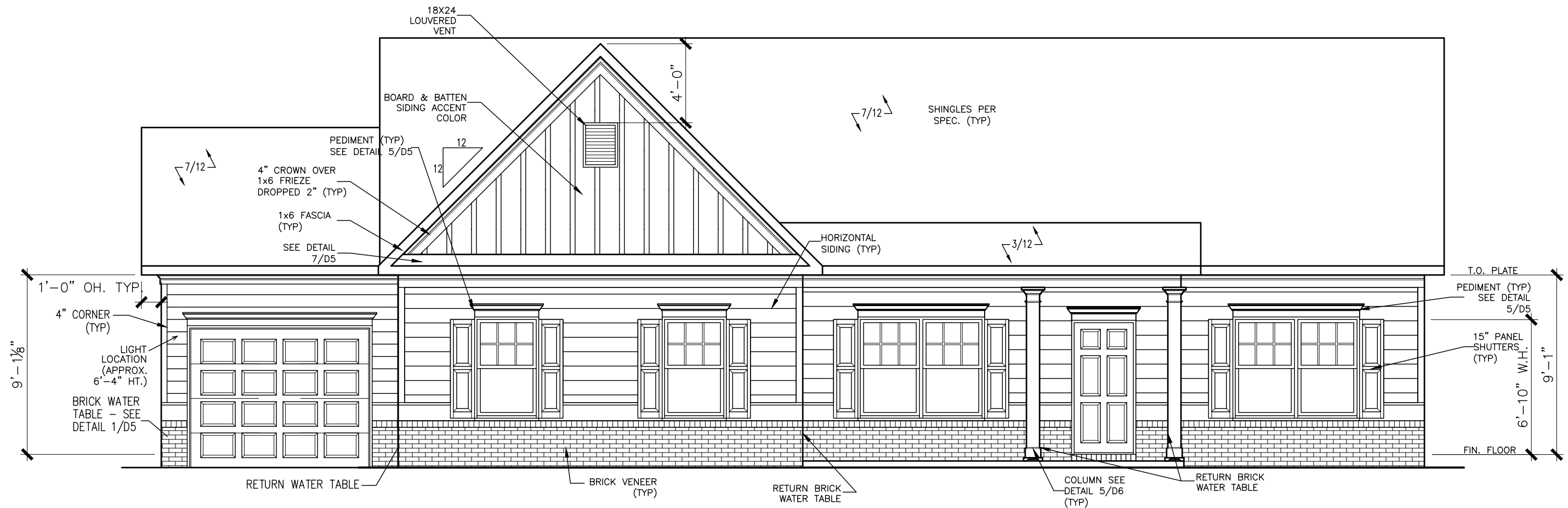

FRONT ELEVATION "B" SIDE ENTRY WITH 3RD CAR GARAGE

SCALE : 1/8" = 1'-0"

ALL NON-MASONRY RETURNS TO
BE HORIZONTAL SIDING

SEE SHEET D3 OF SDH TYPICAL
DETAILS FOR SOFFIT DETAILS PER
SOFFIT MATERIAL

| BY | # | REVISION | DATE |
|----|---|----------|------|
| | | | |
| | | | |
| | | | |
| | | | |



ELEVATIONS
FRONT ELEVATION
VININGS

SMITH DOUGLAS HOMES
110 VILLAGE TRAIL
SUITE 215
WOODSTOCK, GA 30188
www.smithdouglas.com

SMITH DOUGLAS HOMES
expressly reserves its
property rights in these
plans and drawings.
These plans and related
drawings are not to be
reproduced without written
consent from SMITH
DOUGLAS HOMES.

| | |
|-----------------|---------|
| BY: SL | CHK: AW |
| DATE: 4/26/2021 | |
| FACADE OPT: B | |
| PLAN ID: | |
| FND: ALL | ELEV: B |
| PAGE NO: A1.1 | |

CANE MILL ESTATES LOT 6

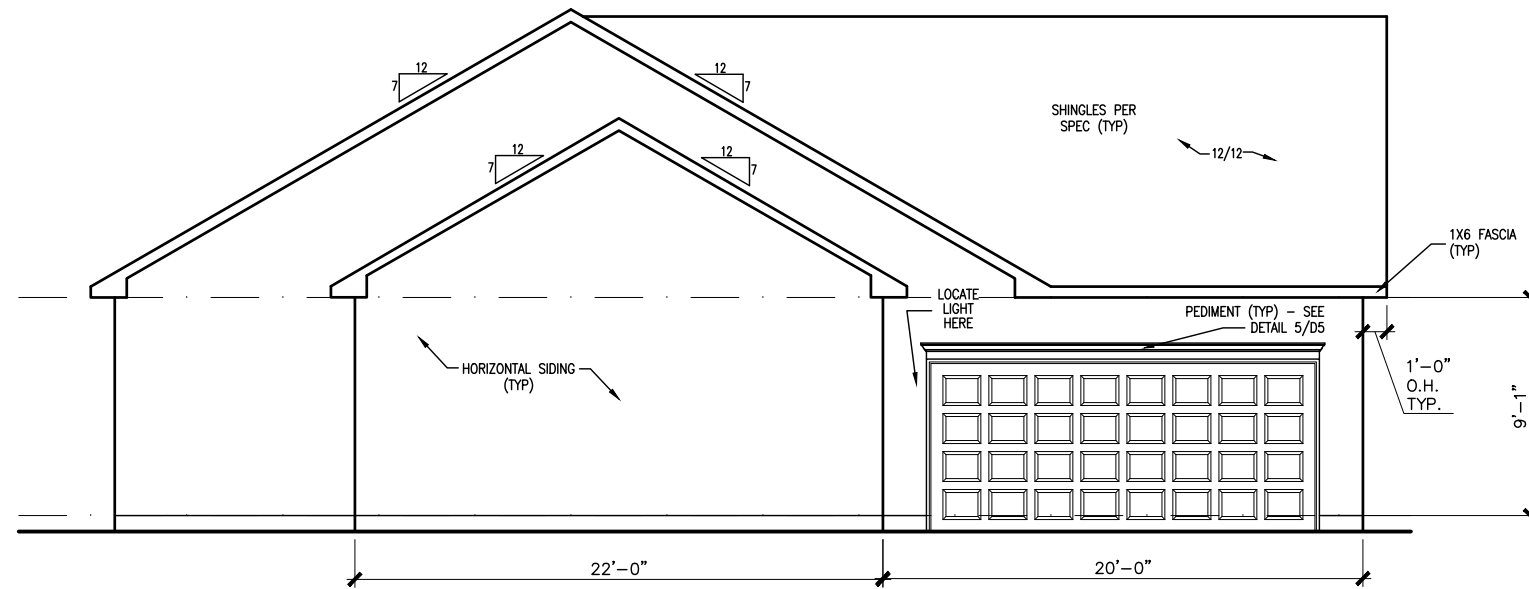

LEFT ELEVATION "B"
SCALE : 1/8" = 1'-0"

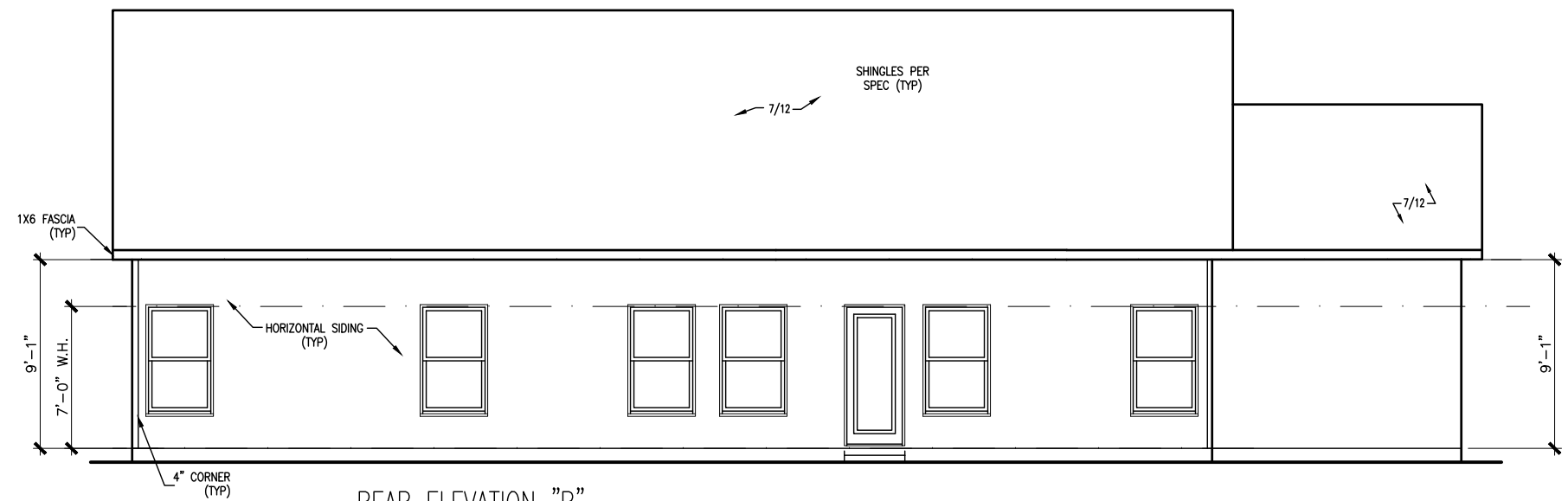

REAR ELEVATION "B"
SCALE : 1/8" = 1'-0"

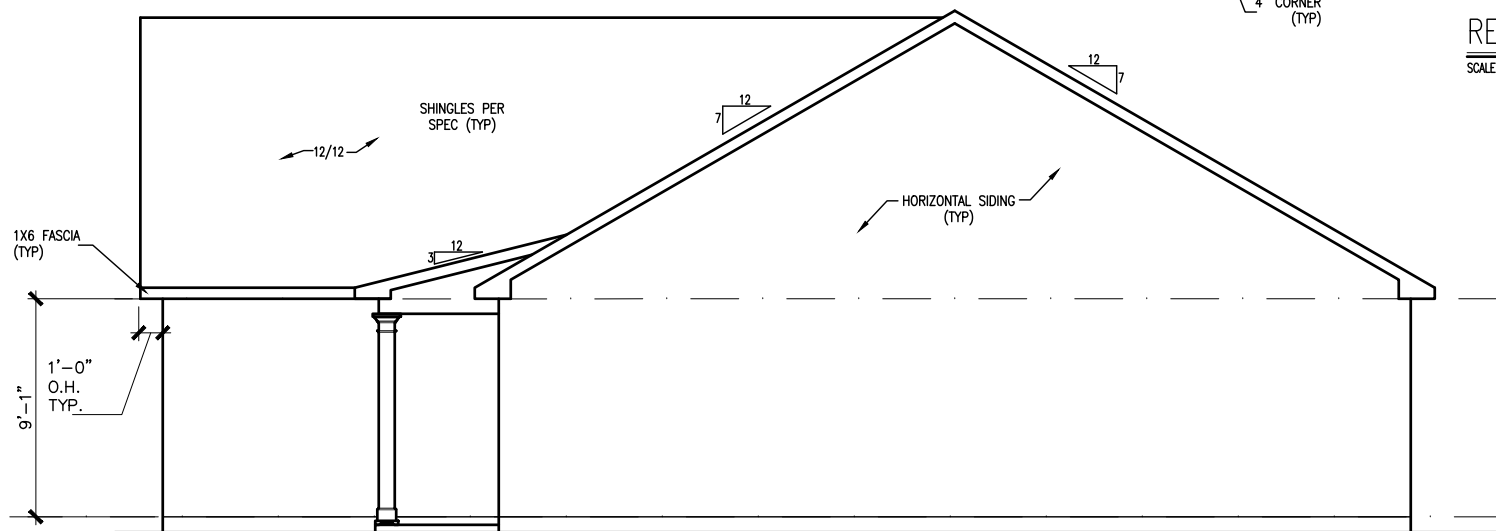

RIGHT ELEVATION "B"
SCALE : 1/8" = 1'-0"

| BY | # | # | # | # | # |
|----------|---|---|---|---|---|
| REVISION | | | | | |
| DATE | | | | | |



ELEVATIONS
SIDES & REAR
VININGS

SMITH DOUGLAS HOMES
110 VILLAGE TRAIL
SUITE 215
WOODSTOCK, GA 30188
www.smithdouglas.com

SMITH DOUGLAS HOMES
expressly reserves its
properly rights in these
plans and drawings.
These plans and related
drawings are not to be
reproduced without written
consent from SMITH
DOUGLAS HOMES.

| | |
|-----------------|---------|
| BY: SL | CHK: AW |
| DATE: 4/26/2021 | |
| FACADE OPT: B | |
| PLAN ID: | |
| FND: ALL | ELEV: B |
| PAGE NO: A2.1 | |

CANE MILL ESTATES LOT 6

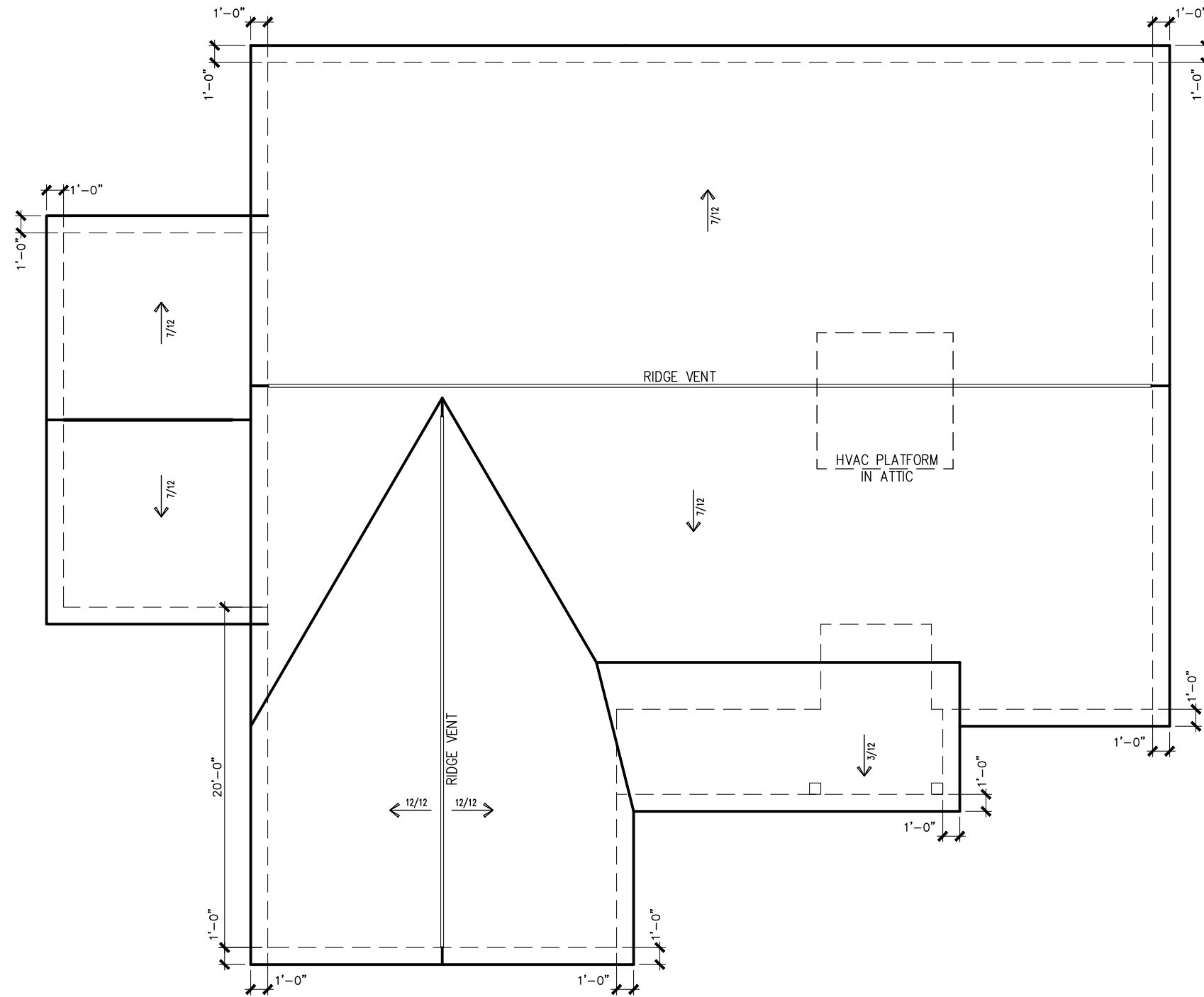

ROOF PLAN "B"

SCALE : 1/8" = 1'-0"

| DATE | REVISION | BY |
|------|----------|----|
| # | # | # |
| # | # | # |
| # | # | # |
| # | # | # |
| # | # | # |



ROOF PLAN
ROOF LAYOUT
VININGS

SMITH DOUGLAS HOMES
110 VILLAGE TRAIL
SUITE 215
WOODSTOCK, GA 30188
www.smithdouglas.com

SMITH DOUGLAS HOMES expressly reserves its property rights in these plans and drawings. These plans and related drawings are not to be reproduced without written consent from SMITH DOUGLAS HOMES.

| | |
|-----------------|---------|
| BY: SL | CHK: AW |
| DATE: 4/26/2021 | |
| FACADE OPT: B | |
| PLAN ID: | |
| FND: ALL | ELEV: B |
| PAGE NO: A6.1 | |

CANE MILL ESTATES LOT 6

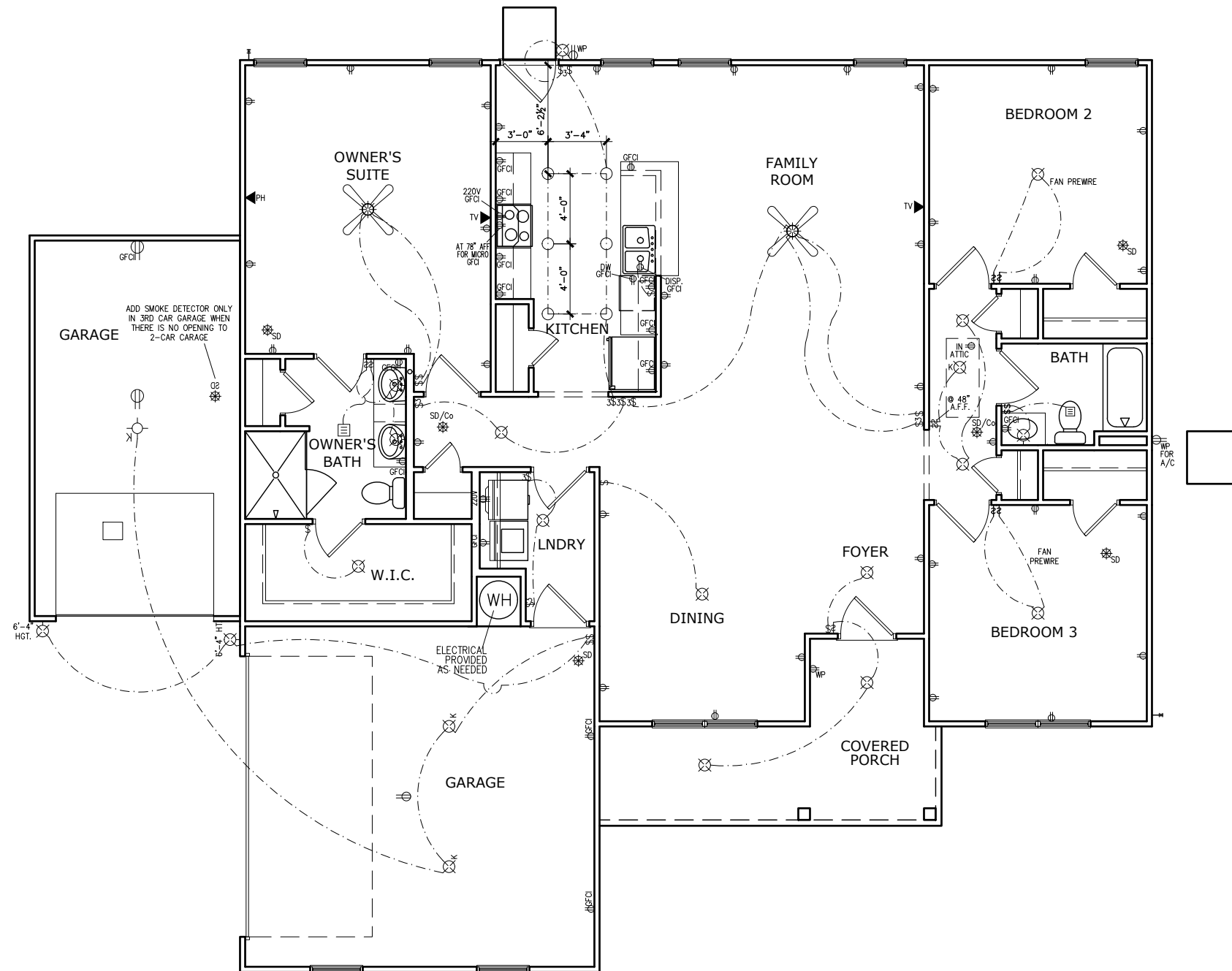

| ELECTRICAL LEGEND | | | |
|-------------------|----------------------------------|-------------------|--------------------------------|
| \$ | SWITCH | TV | TV |
| \$3 | 3 WAY SWITCH | ⊕ | 120V RECEPTACLE |
| \$4 | 4 WAY SWITCH | ⊕ | 120V SWITCHED RECEPTACLE |
| ⊗ | CEILING FIXTURE | ⊕ | 220V RECEPTACLE |
| ⊕ _K | KEYLESS | ⊕ _{GFCI} | GFCI OUTLET |
| ⊗ | WALL MOUNT FIXTURE | ⊕ _{AFCI} | ARCH FAULT CIRCUIT INTERRUPTER |
| ○ | CEILING FIXTURE | † _{GL} | GAS LINE |
| ● | FLEX CONDUIT | † _{WL} | WATER LINE |
| CH | CHIMES | ↓ | HOSE BIBB |
| PH | TELEPHONE | ⊕ | FLOOD LIGHT |
| SD/Co | SMOKE DETECTOR & CARBON MONOXIDE | ⊕ | 1x4 LUMINOUS FIXTURE |
| SO | SECURITY OUTLET | ⊗ | CEILING FAN |
| □ | GARAGE DOOR OPENER | — | ELECTRICAL WIRING |
| ⊕ | EXHAUST FAN | ⊕ | CEILING FIXTURE |
| ⊕ | FAN/LIGHT | | |

ELECTRICAL PLANS TO FOLLOW ALL LOCAL CODES

APPROX. FIXTURE HGTS (MEASURED FROM BOTTOM OF FIXTURE)

| | |
|-------------------------|--------------------------|
| BREAKFAST/DINING ROOM | 63" ABOVE FINISHED FLOOR |
| KITCHEN PENDANT LIGHTS | 33" ABOVE COUNTER TOP |
| TWO STORY FOYER FIXTURE | 96" ABOVE FINISHED FLOOR |
| CEILING FAN | 96" ABOVE FINISHED FLOOR |

NOTE: FINAL PLACEMENT OF PHONE/CABLE T.B.D. ON SITE BY THE BUILDER

FIRST FLOOR ELECTRICAL PLAN

SCALE: 1/8" = 1'-0"

| | | | | | |
|----------|---|---|---|---|---|
| BY | # | # | # | # | # |
| REVISION | | | | | |
| DATE | | | | | |



ELECTRICAL PLAN
FIRST FLOOR
VININGS

SMITH DOUGLAS HOMES
110 VILLAGE TRAIL
SUITE 215
WOODSTOCK, GA 30188
www.smithdouglas.com

SMITH DOUGLAS HOMES expressly reserves its property rights in these plans and drawings. These plans and related drawings are not to be reproduced without written consent from SMITH DOUGLAS HOMES.

| | | | |
|-------------|-----------|-------|----|
| BY: | SL | CHK: | AW |
| DATE: | 4/26/2021 | | |
| FACADE OPT: | B | | |
| PLAN ID: | | | |
| FND: | ALL | ELEV: | B |
| PAGE NO: | A7.2 | | |

CANE MILL ESTATES LOT 6

| | | | | | | |
|----------|---|---|---|---|---|---|
| BY | # | # | # | # | # | # |
| REVISION | | | | | | |
| DATE | | | | | | |



DETAILS
LOT DEFINITION
VININGS

SMITH DOUGLAS HOMES
110 VILLAGE TRAIL
SUITE 215
WOODSTOCK, GA 30188
www.smithdouglas.com

SMITH DOUGLAS HOMES expressly reserves its property rights in these plans and drawings. These plans and related drawings are not to be reproduced without written consent from SMITH DOUGLAS HOMES.

| | | | |
|-------------|-----------|-------|----|
| BY: | SL | CR: | AW |
| DATE: | 4/26/2021 | | |
| FACADE OPT: | B | | |
| PLAN ID: | | | |
| FND: | ALL | ELEV: | B |
| PAGE NO: | A9.1 | | |

Lot Definition

| | |
|---|---|
| Project: Cane Mill Estates Building: 000 Unit: 0006 | Community: Cane Mill Estates Builder: Thomas Kenneth Barlow Status: Sold |
| Plan: Vinings B Ranch Side Entry Orientation: Garage Left Bedrooms: 3 Address: 185 Planters Lane Coats: NC NC: 27521 | Sq. Ft.: 1,819 Bathrooms: 2 Permit: Notes: |
| RTeam: Raleigh West Slot: 5460 | |

| Sales Data | Dates |
|--|---|
| Contract: 89160 Buyer: Marjorie Parish Sales Agent: Sam Fulmer | Ratified: 03/28/2021 Original Start: 04/16/2021 Start: 04/16/2021 Scheduled Complete: 08/26/2021 |

User Name: Victoria Wicker 1 of 3 04/14/2021
Database: SmithDouglasCommunities 10:17:07 AM

Lot Definition

| Option | Description | Quantity |
|---|--|----------|
| 36" Cabinet 2nd Upgr w/ Hardware | Includes hardware - knobs, pulls, or knob/pull combo. Note: Bath cabinets to match | 1 |
| 3rd-Car Garage-SIDE Entry Home-Fiber | Attached 3rd Car Garage on side entry home w/Fiber Cement Siding. NOTE: Location must be on Contract Exhibit floor plan and side plan. NOTE: Builder must approve in writing per lot. Site Exclusions may apply. | 1 |
| Automatic Garage Door Opener | Garage Door Opener - Per Door | 1 |
| Brick 14 C ExtCo(PkgI) | | 1 |
| Ceiling Fan w/Light Family Room | Ceiling fan, including Light Kit. Does not include Prewire. This option is for use in Family Rooms that are pre-wired standard but have no fan. | 1 |
| Ceiling Fan w/Light Owner Bedroom | Ceiling fan, including Light Kit. Does not include Prewire. This option is for use in Owner Bedrooms that are pre-wired standard but have no fan. | 1 |
| Chrome Interior Finish Color Package | Includes chrome kitchen faucet, bath faucets, & fixtures, brushed nickel door hardware (hinges, bumps, knobs/levers, deadbolts), Pkg1 (bn) lighting fixtures, & pewter oval mirror. Separate options also affected: shower door, bath hardware (towel bar/ing, tp holder), shower grab bar, cabinet hardware | 1 |
| Comfort Height Toilet in Owner Bathroom | | 1 |
| FPkg 5AA-Floorte Pro, StdCpt (FPkg1) | Flooring Package 5AA - Floorte Pro, Standard Carpet (from Package 1). SPC (solid polymer core) 0.5 mm vinyl top layer plank | 1 |
| FPkg W1-OwnerBath Tile 1 | Flooring Package - Owner Bath Tile 1 | 1 |
| Granite-Kitchen Countertops - Lvl 1 (I) | Kitchen Granite Countertops - Level 1-where Laminite is Std. | 1 |
| Kitchen Ceiling Fixture Lights ILO Std | Kitchen Lights - Low Profile Flush Mount LED Lights per Plan ILO Standard Light | 1 |
| Level 2 - Package Electric (from E1) | Frigidaire SS 24" Dishwasher*** Frigidaire SS 1.6 Cu. Ft. Micro Frigidaire SS 30" Elec Range | 1 |
| Owner Bath Marble 1 Double lo LamSgl | ***Includes Vanity Double Bowl Option Do Not Select Both*** | 1 |
| PreWire for Ceiling Fan | Pre-wire a light location for a future ceiling fan. | 2 |
| Screens Base House Single Family | Add window screens to all operable standard windows on single family home. NOTE: Does not include screens for windows for optional-2nd-floors, side entry garage, or windows added or changed from structural options, optional windows, or basement windows. See additional options to complete screens. | 1 |
| T1 ZeroEntry Large Shwr FL QBATHC | Large Zero Entry Tile Level 1 Shower w/Frameless clear glass door ILO Large prefab shower. Per Plan. NOTE: Slab only. Not available on Basement builds. (obathc) | 1 |

User Name: Victoria Wicker 2 of 3 04/14/2021
Database: SmithDouglasCommunities 10:17:07 AM

Lot Definition

| Activity | Description | Selection Description |
|--------------------------|--------------------------------|---|
| Ceramic Tile Set - Bath | TILEZeroEntryShwrWaliF1stALL | Omega Silver 150/Silver 00030 |
| Del&Install AppliancePkg | Appliance Package Select - All | Appliance Package Selected |
| Install Cabinets Complet | Cab Hndw Type(2/3)ALL | Pulls |
| Install Cabinets Complet | Cabinet Finish - Upgrade 2Arls | 2nd-Ujg Ellis Purestyle-Stone Gray |
| Install Cabinets Complet | Secondary Bath Vanity Top-All | 4925K-7 Calcutta Marble |
| Install Carpet | Carpet - Standard ALL | Smith Grove II Pearlescent 00100 |
| Install Floorte Pro (LP) | Floorte Pro 1stUpgr ALL | Presto Plus - 703 Deep Mahogany |
| Install Granite Tops | RDU Granite CounterKitchenLvl1 | Dallie-Ashen White |
| Install Marble Tops | RDU Marble Vanity Top Lvl 1 | Mette-#153 White w/ice Grey w/oval bowl |
| Paint Interior Complete | Interior Paint (Trim) | SW 7006 Extra White |
| Paint Interior Complete | Interior Paint (Walls) - Base | SW 8917 Shell White |
| PM - Tile Floor Complete | TILE Floor-1stUpgr ALL | Omega Silver 150(13x13)/Silver 00030 |
| PM Install Vinyl Floor | VinyFPkg-Std 2nd Baths/Laundry | Highlands II Glacier 561 |

User Name: Victoria Wicker 3 of 3 04/14/2021
Database: SmithDouglasCommunities 10:17:07 AM



PROJECT
Vining (LH)
Coversheet
Client
Smith Douglas Homes - Raleigh
2520 Reliance Ave
Apex, NC 27539

CURRENT DRAWING
DATE: 10/12/09
SCALE: 1/8"=1'-0"
PROJECT #: 383226R2
DRAIN BY: MEB
CHECKED BY: ONB

ORIGINAL DRAWING
DATE
08/07/2008 3832.54

REFER TO COVER SHEET FOR A COMPLETE LIST OF REVISIONS

SHEET

CS2

WOOD STRUCTURAL PANELS:

- Fabrication and placement of structural wood sheathing shall be in accordance with the APA Design/Construction Guide "Residential and Commercial", and all other applicable APA standards.
- All structurally required wood sheathing shall bear the mark of the APA.
- Wood wall sheathing shall comply with the requirements of local building codes for the appropriate state as indicated on these drawings. Refer to wall bracing notes in plan set for more information. Sheathing shall be applied with the long direction perpendicular to framing, unless noted otherwise.
- Roof sheathing shall be APA rated sheathing exposure 1 or 2. Roof sheathing shall be continuous over two supports and attached to its supporting roof framing with (1)-8d CC nail at 6" o/c at panel edges and at 12" o/c in panel field unless otherwise noted on the plans. Sheathing shall be applied with the long direction perpendicular to framing. Sheathing shall have a span rating consistent with the framing spacing. Use suitable edge support by use of plywood clips or lumber blocking unless otherwise noted. Panel end joints shall occur over framing. Apply building paper over the sheathing as required by the state Building Code.
- Wood floor sheathing shall be APA rated sheathing exposure 1 or 2. Attach sheathing to its supporting framing with (1)-8d CC ringshank nail at 6" o/c at panel edges and at 12" o/c in panel field unless otherwise noted on the plans. Sheathing shall be applied perpendicular to framing. Sheathing shall have a span rating consistent with the framing spacing. Use suitable edge support by use of T&G plywood or lumber blocking unless otherwise noted. Panel end joints shall occur over framing. Apply building paper over the sheathing as required by the state Building Code.
- Sheathing shall have a 1/8" gap at panel ends and edges as recommended in accordance with the APA.

STRUCTURAL FIBERBOARD PANELS:

- Fabrication and placement of structural fiberboard sheathing shall be in accordance with the applicable APA standards.
- Fiberboard wall sheathing shall comply with the requirements of local building codes for the appropriate state as indicated on these drawings. Refer to wall bracing notes in plan set for more information.
- Sheathing shall have a 1/8" gap at panel ends and edges as recommended in accordance with the APA.

EXTERIOR WOOD FRAMED DECKS:

- Decks are to be framed in accordance with local building codes and as referenced on the structural plans, either through code references or construction details.

STRUCTURAL STEEL:

- Structural steel shall be fabricated and erected in accordance with the American Institute of Steel Construction "Code of Standard Practice for Steel Buildings and Bridges" and of the manual of Steel Construction "Load Resistance Factor Design" latest editions.
- All steel shall have a minimum yield stress (Fy) of 36 ksi unless otherwise noted.
- Welding shall conform to the latest edition of the American Welding Society's Structural Welding Code AWS D.11. Electrodes for shop and field welding shall be class E70XX. All welding shall be performed by a certified welder per the above standards.

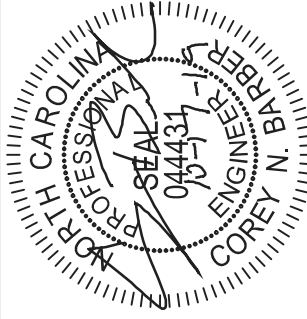

Cane Mill
Lot 6

STRUCTURAL MEMBERS ONLY

WOOD FRAMING:

- Solid sawn wood framing members shall conform to the specifications listed in the latest edition of the "National Design Specification for Wood Construction" (NDS). Unless otherwise noted, all wood framing members are designed to be Spruce-Pine-Fir (SPF) #2.
- LVL or PSL engineered wood shall have the following minimum design values:
2.1. E = 19000000 psi
2.2. Fb = 2600 psi
2.3. Fv = 285 psi
2.4. Fc = 100 psi
- Wood in contact with concrete, masonry, or earth shall be pressure treated in accordance with AIAA standard C-15. All other moisture exposed wood shall be treated in accordance with AIAA standard C-2
- Nails shall be common wire nails unless otherwise noted.
- Lag screws shall conform to ANSI/ASME standard B18.2.1-1981. Lead holes for lag screws shall be in accordance with NDS specifications.
- All beams shall have full bearing on supporting framing members unless otherwise noted.
- Exterior and load bearing stud walls are to be 2x4 SPF#2 #16" O.C. unless otherwise noted. Studs shall be continuous from the sole plate to the double top plate. Studs shall only be discontinuous at headers for window/door openings. A minimum of one king stud shall be placed at each end of the header. King studs shall be continuous.
- Individual studs forming a column shall be attached with one 10d nail #6" O.C. staggered. The stud column shall be continuous to the foundation or beam. The column shall be fully blocked at all floor levels to ensure proper load transfer.
- Multi-ply beams shall have each ply attached with (3)10d nails # 24" O.C.
- Flitch beams and four and five ply beams shall be bolted together with (2) rows of 1/2" dia. through bolts staggered #7.4" O.C. w/ 2" edge distance and (2) bolts located at 6" from each end, unless noted otherwise.

WOOD TRUSSES:

- The wood truss manufacturer/fabricator is responsible for the design of the wood trusses. Submit sealed shop drawings and supporting calculations to the SER for review prior to fabrication. The SER shall have a minimum of five (5) days for review. The review by the SER shall review for overall compliance with the design documents. The SER shall assume no responsibility for the correctness for the structural design for the wood trusses.
- The wood trusses shall be designed for all required loadings as specified in the local building code, the ASCE Standard "Minimum Design Loads for Buildings and Other Structures" (ASCE 7-10), and the loading requirements shown on these specifications. The truss drawings shall be coordinated with all other construction documents and provisions provided for loads shown on these drawings including but not limited to HVAC equipment, piping, and architectural fixtures attached to the trusses.
- The trusses shall be designed, fabricated, and erected in accordance with the latest edition of the "National Design Specification for Wood Construction." (NDS) and "Design Specification for Metal Plate Connected Wood Trusses." The truss manufacturer shall provide adequate bracing information in accordance with "Commentary and Recommendations for Handing, Installing, and Bracing Metal Plate Connected Wood Trusses" (HIB-5). This bracing, both temporary and permanent, shall be shown on the shop drawings. Also, the shop drawings shall show the required attachments for the trusses.
- Any chords or truss webs shown on these drawings have been shown as a reference only. The final design of the trusses shall be per the manufacturer.

CONCRETE:

- Concrete shall have a normal weight aggregate and a minimum compressive strength (f'c) at 28 days of 3000 psi, unless otherwise noted on the plan.
- Concrete shall be proportioned, mixed, and placed in accordance with the latest editions of ACI 318: "Building Code Requirements for Reinforced Concrete" and ACI 301: "Specifications for Structural Concrete for Buildings".
- Air entrained concrete must be used for all structural elements exposed to freeze/thaw cycles and deicing chemicals. Air entrainment amounts (in percent) shall be within -1% to 4% of target values as follows:
3.1. Footings: 5%
3.2. Exterior Slabs: 5%
3.3. Admixtures shall be added to any structural concrete without written permission of the SER
- Concrete slabs-on-grade shall be constructed in accordance with ACI 302.1R-96: "Guide for Concrete Slab and Slab Construction".
- The concrete slab-on-grade has been designed using a subgrade modulus of k=250 pci and a design loading of 200 psf. The SER is not responsible for differential settlement, slab cracking or other future defects resulting from unreported conditions not in accordance with the above assumptions.
- Control or saw cut joints shall be spaced in interior slabs-on-grade at a maximum of 15'-0" O.C. and in exterior slabs-on-grade at a maximum of 10'-0" unless otherwise noted.
- Control or saw cut joints shall be produced using conventional process within 4 to 12 hours after the slab has been finished
- Reinforcing steel may not extend through a control joint. Reinforcing steel may extend through a saw cut joint.
- All welded wire fabric (WWF) for concrete slabs-on-grade shall be placed at mid-depth of slab. The WWF shall be securely supported during the concrete pour. Fibermesh may be used in lieu of WWF.

CONCRETE REINFORCEMENT:

- Fibrous concrete reinforcement, or fibermesh, specified in concrete slabs-on-grade may be used for control of cracking due to shrinkage and thermal expansion/contraction, lowered water migration, an increase in impact capacity, increased abrasion resistance, and residual strength.
- Fibermesh reinforcing to be 100% virgin polypropylene fibers containing no reprocessed olefin materials and specifically manufactured for use as concrete secondary reinforcement.
- Application of fibermesh per cubic yard of concrete shall equal a minimum of 0.1% by volume (1.5 pounds per cubic yard)
- Fibermesh shall comply with ASTM C116, any local building code requirements, and shall meet or exceed the current industry standard.
- Steel Reinforcing bars shall be new billet steel conforming to ASTM A615, grade 60.
- Detailing, fabrication, and placement of reinforcing steel shall be in accordance with the latest edition of ACI 318: "Manual of Standard Practice for Detailing Concrete Structures"
- Horizontal footing and wall reinforcement shall be continuous and shall have 90° bends, or corner bars with the same size/spacing as the horizontal reinforcement with a class B tension splice.
- Lap reinforcement as required, a minimum of 40 bar diameters for tension or compression unless otherwise noted. Splices in masonry shall be a minimum of 48 bar diameters.
- Where reinforcing dowels are required, they shall be equivalent in size and spacing to the vertical reinforcement. The dowel shall extend 48 bar diameters vertically and 20 bar diameters into the footing.
- Where reinforcing steel is required vertically, dowels shall be provided unless otherwise noted.

GENERAL STRUCTURAL NOTES:

- The design professional whose seal appears on these drawings is the structural engineer of record (SER) for this project. The SER bears the responsibility of this structure. No structural elements and the performance of this structure. No other party may revise, alter, or delete any structural aspects of these construction documents without written permission of the SER. For the purposes of these construction documents the SER and SUMMIT shall be considered the same entity.
- The structure is only stable in its completed form. The contractor shall provide all required temporary bracing during construction to stabilize the structure.
- The SER is not responsible for construction sequences, methods, or techniques in connection with the construction of this structure. The SER will not be held responsible for the contractor's failure to conform to the contract documents, should any non-conformities occur.
- Any structural elements or details not fully developed on the construction drawings shall be completed under the direction of a licensed professional engineer. These shop drawings shall be submitted to SUMMIT for review before any construction begins. The shop drawings will be reviewed for overall compliance as it relates to the structural design of this project. Verification of the shop drawings for dimensions, or for actual field conditions, is not the responsibility of the SER or SUMMIT.
- Verification of assumed field conditions is not the responsibility of the SER. The contractor shall verify the field conditions for accuracy and report any discrepancies to SUMMIT before construction begins.
- The SER is not responsible for any secondary structural elements or non-structural elements, except for the elements specifically noted on the structural drawings.
- This structure and all construction shall conform to all applicable sections of the International Residential Code.
- This structure and all construction shall conform to all applicable sections of the 2008 North Carolina Residential Code (NRC) and any local codes or restrictions

FOUNDATIONS:

- Foundations shall be constructed in accordance with chapter 4 of the 2008 NC Residential Building Code (Special consideration shall be given to Chapter 45 in wind zones above 150mph)
- Footing sizes based on a presumptive soil bearing capacity of 2000 PSF. Contractor is solely responsible for verifying the suitability of the site soil conditions at the time of construction
- Maximum depth of unbalanced fill against masonry walls to be as specified in section R404.1 of the 2008 NRC
- The structural engineer has not performed a subsurface investigation. Verification of this assumed value is the responsibility of the owner or the contractor. Should any adverse soil condition be encountered the SER must be contacted before proceeding.
- The bottom of all footings shall extend below the frost line for the region in which the structure is to be constructed. However, the bottom of all footings shall be a minimum of 12" below grade.
- Any fill shall be placed under the direction or recommendation of a licensed professional engineer. The resulting soil shall be compacted to a minimum of 95% maximum dry density.
- Excavations of footings shall be lined temporarily with a 6 mil polyethylene membrane if placement of concrete does not occur within 24 hours of excavation.
- No concrete shall be placed against any subgrade containing water, ice, frost, or loose material.
- Each crawl space pier shall bear in the middle third of its respective footing and each girder shall bear in the middle third of the piers. Plasters to be bonded to perimeter foundation wall
- Crawl spaced to be graded level and clear of all debris
- Provide foundation waterproofing and drain with positive slope to outlet as required by site conditions
- Energy efficiency compliance and insulation of the structure to be in accordance with chapter 11 of the 2008 NRC

SEE SHEET S1.0m FOR NOTES AND MORE INFORMATION

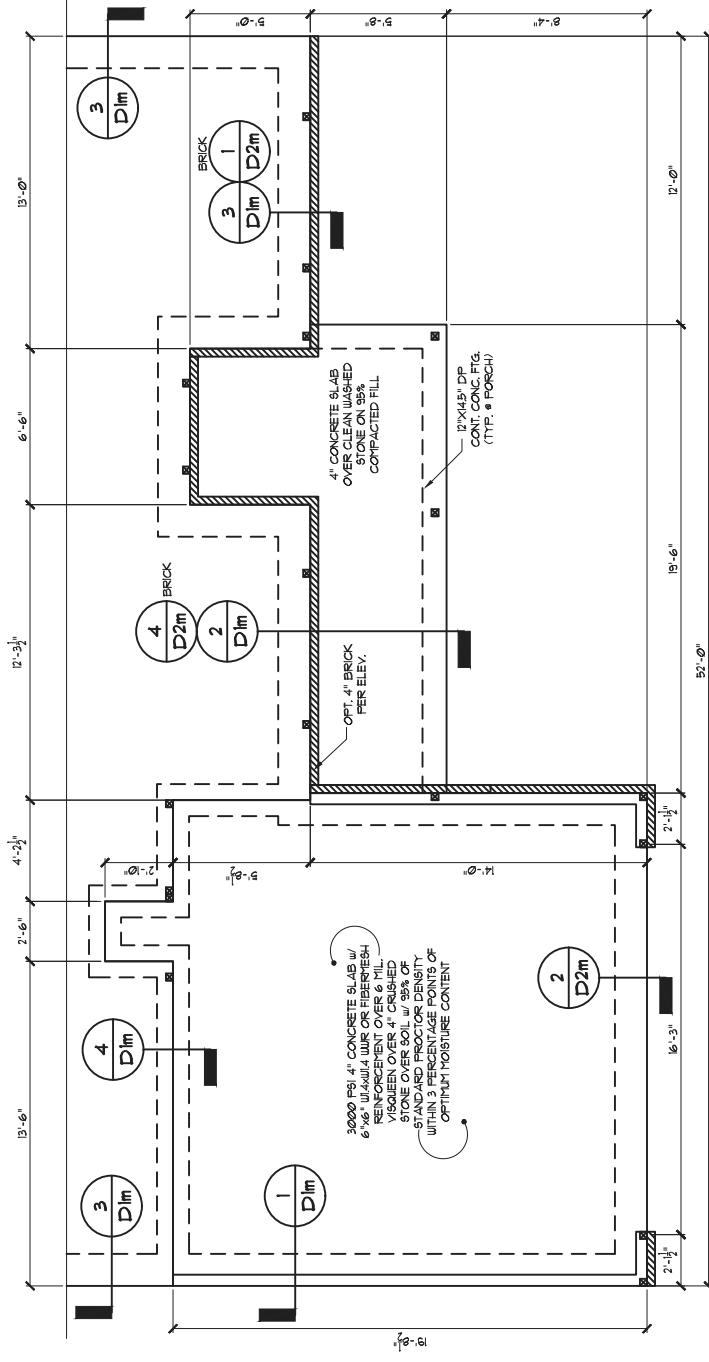

ELEVATIONS BEH

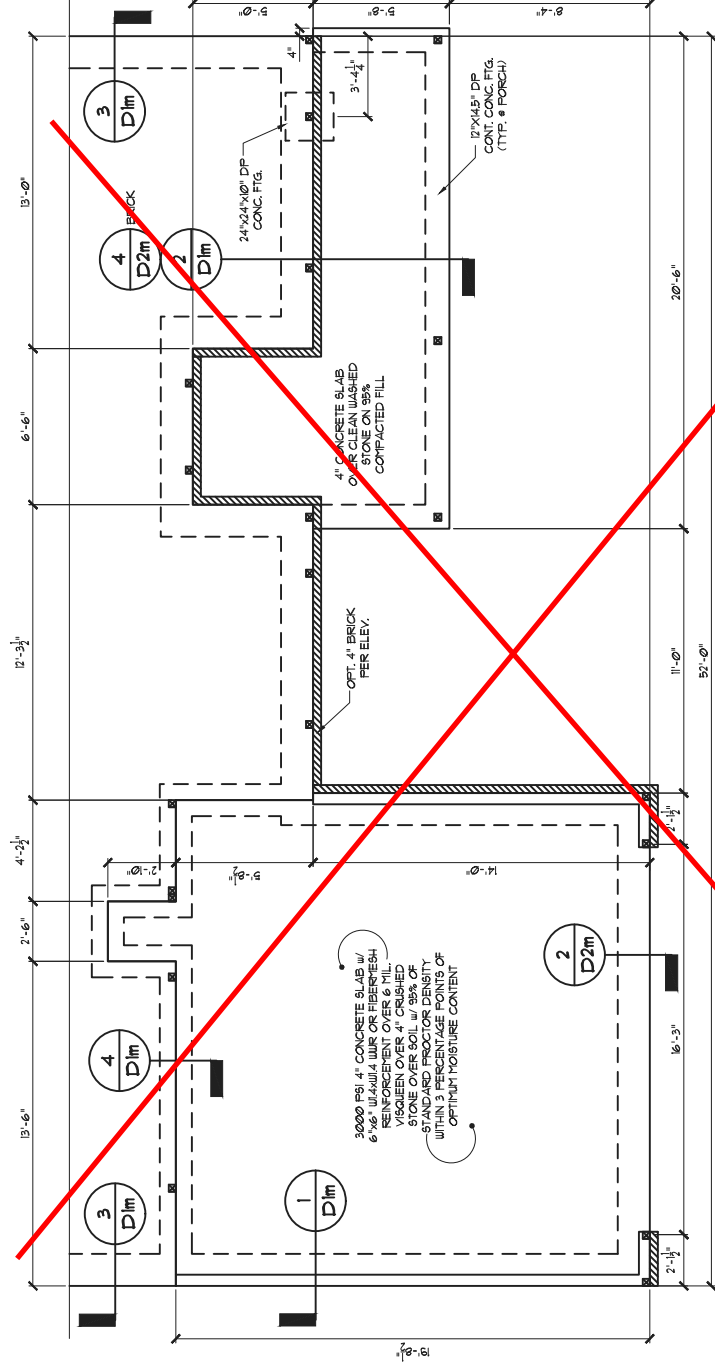

ELEVATIONS CEI

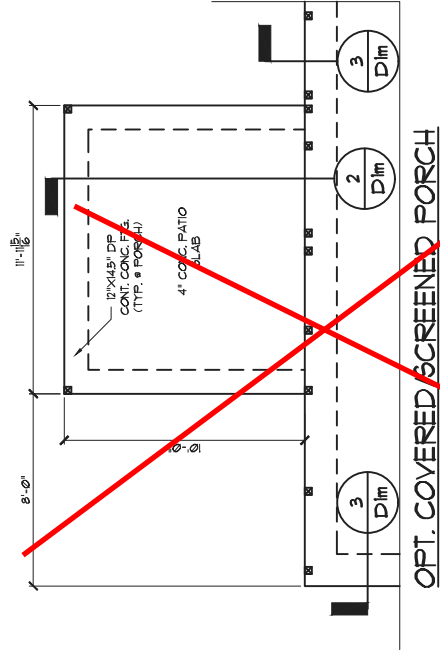

OPT. COVERED/SCREENED PORCH

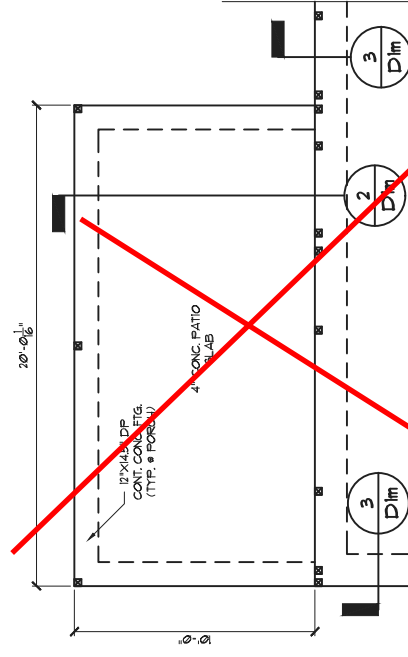

OPT. EXTENDED COVERED/SCREENED PORCH

STRUCTURAL MEMBERS ONLY
ENGINEERING SEAL APPLIES ONLY TO STRUCTURAL COMPONENTS ON THIS DOCUMENT. SEAL DOES NOT INCLUDE CONSTRUCTION MEANS, METHODS, TECHNIQUES, SEQUENCES, PROCEDURES OR SAFETY PRECAUTIONS. ANY DEVIATIONS OR DISCREPANCIES ON PLANS ARE TO BE BROUGHT TO THE IMMEDIATE ATTENTION OF SUMMIT ENGINEERING, LABORATORY & TESTING, P.C. FAILURE TO DO SO WILL VOID SUMMIT LIABILITY.

STRUCTURAL ANALYSIS BASED ON 2016 NCRS.

MONOLITHIC SLAB FOUNDATION
SCALE: 1/8"=1'

Cane Mill Lot 6



STRUCTURAL MEMBERS ONLY

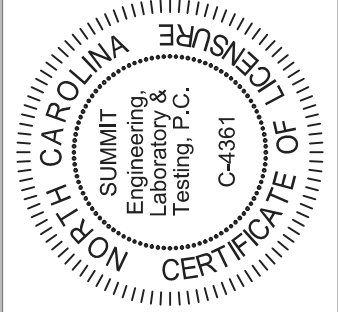

PROJECT
Vinyngs (LH)
First Floor Framing
Client
Smith Douglas Homes - Raleigh
2520 Reliance Ave
Apex, NC 27539

CURRENT DRAWING
DATE: 10/17/2018
SCALE: 1/8"=1'-0"
PROJECT #: 383226R2
DRAIN BY: MEB
CHECKED BY: CNB
ORIGINAL DRAWING
DATE PROJECT #
08/07/2018 3832154

REFER TO COVER SHEET FOR A COMPLETE LIST OF REVISIONS

SEE SHEET S3.0 FOR NOTES AND MORE INFORMATION

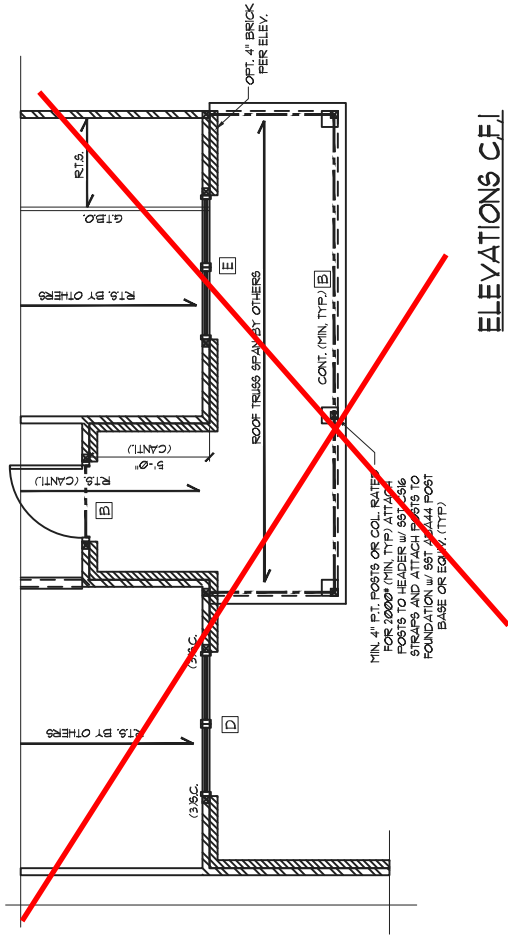

ELEVATIONS C.F.I.

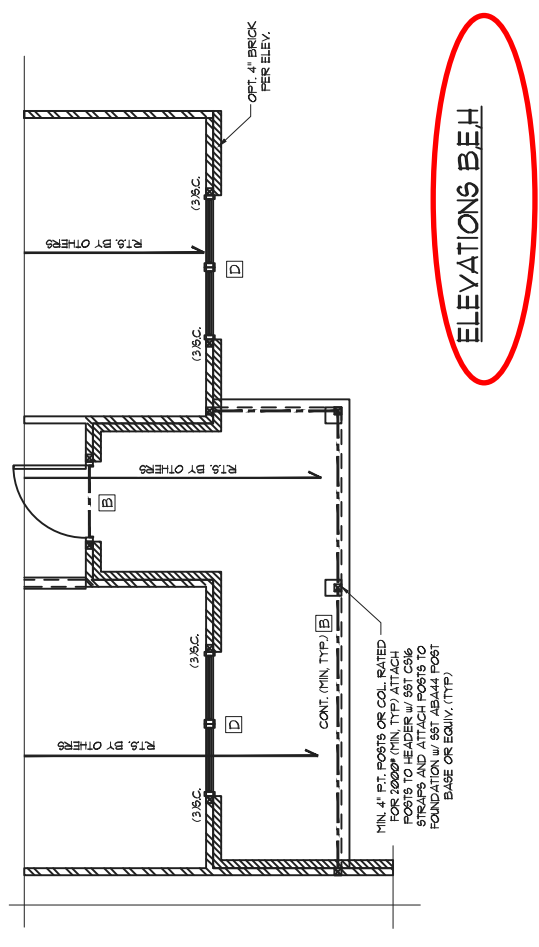

ELEVATIONS BEH

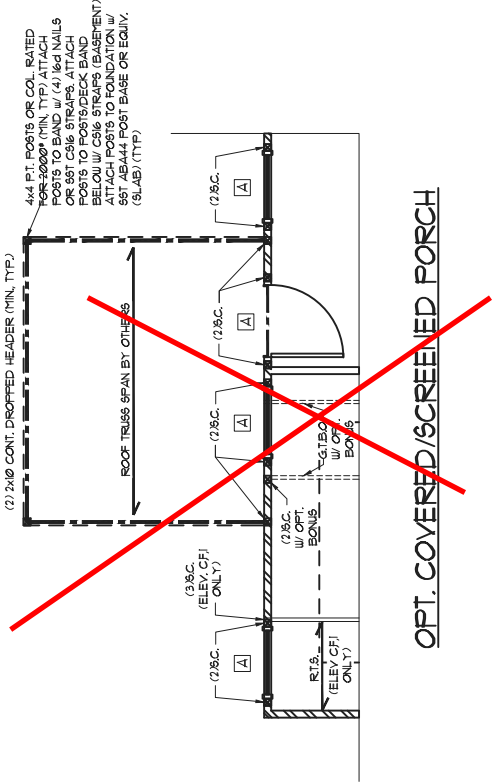

OPT. COVERED/SCREENED PORCH

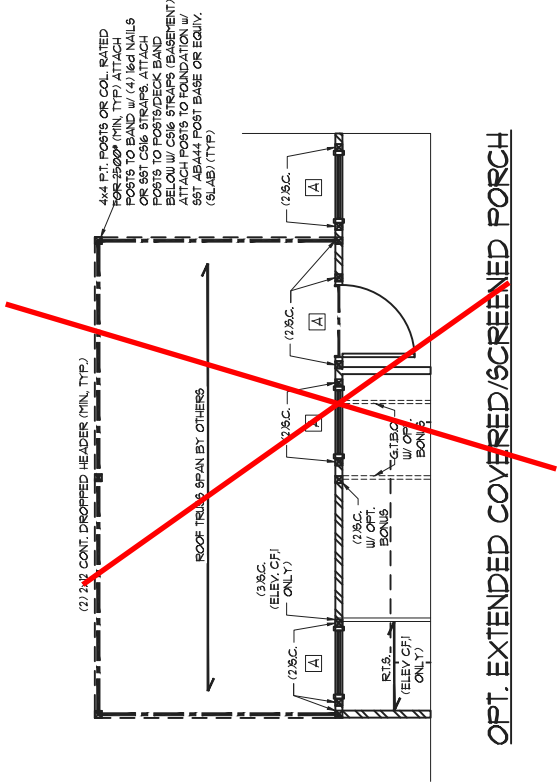

OPT. EXTENDED COVERED/SCREENED PORCH

STRUCTURAL MEMBERS ONLY
ENGINEERING SEAL APPLIES ONLY TO STRUCTURAL COMPONENTS ON THIS DOCUMENT. SEAL DOES NOT INCLUDE CONSTRUCTION MEANS, METHODS, TECHNIQUES, SEQUENCES, PROCEDURES OR SAFETY PRECAUTIONS. ANY DEVIATIONS OR DISCREPANCIES ON PLANS ARE TO BE BROUGHT TO THE IMMEDIATE ATTENTION OF SUMMIT ENGINEERING, LABORATORY & TESTING, P.C. FAILURE TO DO SO WILL VOID SUMMIT LIABILITY.
STRUCTURAL ANALYSIS BASED ON 2016 NCR.C.

Cane Mill
Lot 6

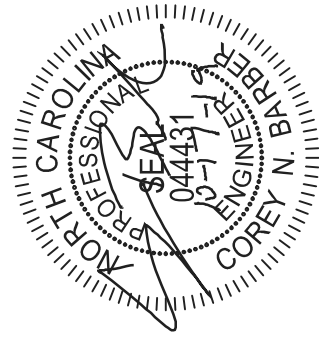

STRUCTURAL MEMBERS ONLY

| TRUSS UPLIFT CONNECTOR SCHEDULE | | | |
|---------------------------------|--------------|--------------------------------|-------------|
| MAX UPLIFT | ROOF TO WALL | FLOOR TO FLOOR | FLOOR TO RD |
| 895 LBS | H23A | PER WALL SHEATHING & FASTENERS | |
| 1970 LBS | (2) H23A | C2K6 (END • B') | DTTZZ |
| 1248 LBS | H1950 | C2K6 (END • B') | DTTZZ |
| 1708 LBS | (2) H1950 | C2K6 (END • B') | DTTZZ |
| 2480 LBS | (2) H1950 | (2) C2K6 (END • B') | HTT4 |
| 2949 LBS | LGT3-S2825 | (2) C2K6 (END • B') | HTT4 |

1. ALL PRODUCTS LISTED ARE STRONG-STOCKS-THE EQUIVALENT PRODUCTS MAY BE USED PER MANUFACTURER'S SPECIFICATIONS.
2. ALL PRODUCTS LISTED ARE STRONG-STOCKS-THE EQUIVALENT PRODUCTS MAY BE USED PER MANUFACTURER'S SPECIFICATIONS.
3. REFER TO TRUSS LAYOUT PER PLAN FOR UPLIFT VALUES AND TRUSS TO TRUSS CONNECTIONS SPECIFIED BY TRUSS MANUFACTURER. OVERRIDES THOSE LISTED ABOVE.
4. CONTACT SUPPLIER FOR REQUIRED CONNECTIONS WHEN LOADS EXCEED THOSE LISTED ABOVE.

NOTE: 1/2" PLY OF ALL SHOWN GROUND TRUSSES TO ALIGN WITH INSIDE FACE OF WALL (TYP. UNO)

NOTE: ROOF TRUSSES SHALL BE SPACED TO SUPPORT FALSE FRAMED DORMER WALLS (TYP. UNO)

NOTE: TRUSS UPLIFT LOADS SHALL BE DETERMINED PER TRUSS MANUFACTURER IN ACCORDANCE WITH SECTION 1803.01 WALL SHEATHING AND FASTENERS HAVE BEEN DESIGNED TO RESIST THE WIND UPLIFT LOAD WITH IN ACCORDANCE WITH METHODS OF SECTION 1803.01 OF THE 2006 IRC. BRACED WALL PLANS FOR SHEATHING AND FASTENER REQUIREMENTS.

THESE PLANS ARE DESIGNED IN ACCORDANCE WITH ARCHITECTURAL PLANS DATED 10/17/2018. THE RESPONSIBILITY OF THE CLIENT TO NOTIFY SUMMIT ENGINEERING, LABORATORY & TESTING, P.C. OF ANY CHANGES MADE TO THE ARCHITECTURAL PLANS PRIOR TO CONSTRUCTION. SUMMIT ENGINEERING, LABORATORY & TESTING, P.C. CANNOT BE HELD RESPONSIBLE FOR ANY CHANGES MADE TO THE ARCHITECTURAL PLANS DATED DIFFERENTLY THAN THE DATE LISTED ABOVE.

STRUCTURAL MEMBERS ONLY
ENGINEERING SEAL APPLIES ONLY TO STRUCTURAL COMPONENTS ON THIS DOCUMENT. SEAL DOES NOT INCLUDE CONSTRUCTION MEANS, METHODS, TECHNIQUES, SEQUENCES, PROCEDURES OR SAFETY PRECAUTIONS. ANY DEVIATIONS OR DISCREPANCIES ON PLANS ARE TO BE BROUGHT TO THE IMMEDIATE ATTENTION OF SUMMIT ENGINEERING, LABORATORY & TESTING, P.C. FAILURE TO DO SO WILL VOID SUMMIT LIABILITY.
STRUCTURAL ANALYSIS BASED ON 2016 NCRC.

ROOF FRAMING PLAN

SCALE: 1/8"=1'

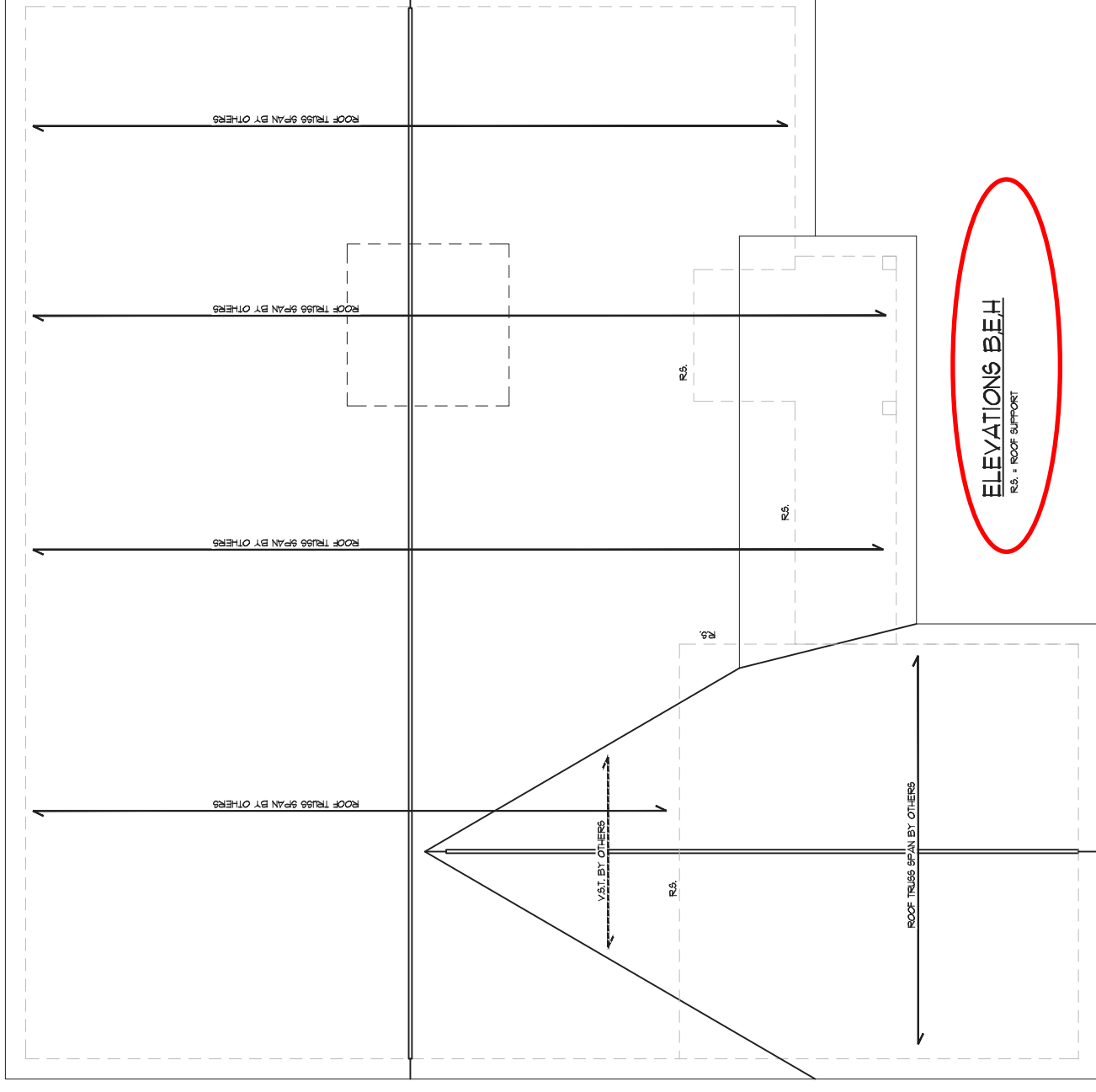

Cane Mill
Lot 6



STRUCTURAL MEMBERS ONLY

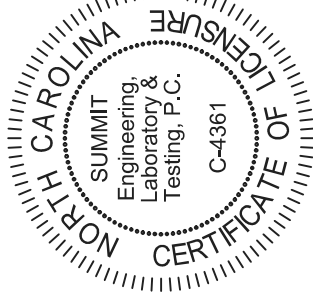

PROJECT
Yivings (LH)
Roof Framing Plan
CLIENT
Smith Douglas Homes - Raleigh
2520 Reliance Ave
Apex, NC 27539

CURRENT DRAWING

DATE: 10/17/2018

SCALE: 1/8"=1'-0"

PROJECT #: 3832226R2

DRAIN BY: MEB

CHECKED BY: CNB

ORIGINAL DRAWING

DATE PROJECT #

08/07/2018 3832254

REFER TO COVER SHEET FOR A COMPLETE LIST OF REVISIONS

SHEET

S5.1

REQUIRED BRACED WALL PANEL CONNECTIONS

| METHOD | MATERIAL | MIN. THICKNESS | REQUIRED CONNECTION |
|--------|------------------------|----------------|--|
| CS-WBP | WOOD STRUCTURAL PANEL | 3/8" | • INTERMEDIATE SHEARWALLS • 6d COMMON NAILS @ 6" O.C. |
| GS | GYPSUM BOARD | 1/2" | • 5d COOLER NAILS @ 1" O.C. |
| WBP | WOOD BRACED WALL PANEL | 3/8" | • 6d COMMON NAILS @ 6" O.C. |
| PF | STEEL PORTAL FRAME | 1/16" | PER FIGURE R6602.101 |

*OR EQUIVALENT PER TABLE R1023.3

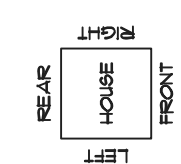

- BRACED WALL NOTES:**
- WALLS SHALL BE DESIGNED IN ACCORDANCE WITH SECTION R6602.10 FROM THE 2018 NORTH CAROLINA RESIDENTIAL CODE.
 - WALLS ARE DESIGNED FOR SEISMIC ZONES A-C AND ULTIMATE WIND SPEEDS UP TO 150 MPH.
 - ALL BRACED WALL PANELS SHALL BE AN ANCHORED OR UNANCHORED TYPE AS SHOWN ON THE DRAWING.
 - BRACED WALL PANELS SHALL BE DESIGNED IN ACCORDANCE WITH TABLE R6602.101.
 - ALL BRACED WALL PANELS SHALL BE FULL WALL HEIGHT AND SHALL NOT EXCEED 10 FEET FOR ISOLATED PANEL METHOD AND 8 FEET FOR CONTINUOUS SHEATHING METHOD WITHOUT ADDITIONAL ENGINEERING CALCULATIONS.
 - MINIMUM PANEL LENGTH SHALL BE PER TABLE R6602.101.
 - THE INTERIOR SIDE OF EXTERIOR WALLS AND BOTH SIDES OF INTERIOR WALLS SHALL BE SHEATHED CONTINUOUSLY WITH MINIMUM 1/2" GYPSUM BOARD.
 - FOR CONTINUOUS SHEATHING METHOD, EXTERIOR WALLS SHALL BE SHEATHED ON ALL SHEATHABLE SURFACES INCLUDING WELLS, AREAS BETWEEN BRACED WALL PANELS, ABOVE AND BELOW WALL OPENINGS, AND ON GABLE END WALLS.
 - ALL BRACED WALL PANELS SHALL BE FULL HEIGHT AND SHALL NOT EXCEED 10 FEET FOR ISOLATED PANEL METHOD AND 8 FEET FOR CONTINUOUS SHEATHING METHOD WITHOUT ADDITIONAL ENGINEERING CALCULATIONS.
 - A BRACED WALL PANEL SHALL BE LOCATED WITHIN 12 FEET OF EACH END OF A BRACED WALL LINE.
 - THE DISTANCE BETWEEN BRACED WALL PANELS SHALL NOT EXCEED 21 FEET.
 - MASONRY OR CONCRETE STEEL WALLS WITH A LENGTH OF 40' OR LESS SUPPORTING A BRACED WALL PANEL SHALL BE DESIGNED IN ACCORDANCE WITH FIGURE R6602.103 OF THE 2018 NCRC.
 - BRACED WALL PANEL CONNECTIONS TO ROOF SHALL BE CONSTRUCTED IN ACCORDANCE WITH SECTION R6602.101.
 - CEILING WALLS AND WALL CUT FLASHING WALLS SHALL BE CONSTRUCTED IN ACCORDANCE WITH SECTION R6602.101.
 - PORTAL WALLS SHALL BE DESIGNED IN ACCORDANCE WITH FIGURE R6602.101 (IND).
 - ON SCHEMATIC, SHADOWED WALLS INDICATE BRACED WALL PANELS.
- ABBREVIATIONS:
 GB = GYPSUM BOARD
 CS-WBP = CONT. SHEATHED WOOD BRACED WALL PANEL
 PF = PORTAL FRAME
 WBP = WOOD STRUCTURAL PANEL
 GS-WBP = CONT. SHEATHED WOOD BRACED WALL PANEL
 PF-WBP = ENG. PORTAL FRAME

THESE PLANS ARE DESIGNED IN ACCORDANCE WITH ARCHITECTURAL PLANS PROVIDED BY SMITH DOUGLAS HOMES. UNLESS COMPLETED/REVISED ON DRAWING, IT IS THE RESPONSIBILITY OF THE CLIENT TO NOTIFY SMITH ENGINEERING LABORATORY & TESTING, P.C. OF ANY CHANGES TO THE ARCHITECTURAL PLANS. SMITH ENGINEERING LABORATORY & TESTING, P.C. CANNOT GUARANTEE THE ADEQUACY OF THESE STRUCTURAL PLANS WHEN USED WITH ARCHITECTURAL PLANS DATED DIFFERENTLY THAN THE DATE LISTED ABOVE.

FIRST FLOOR BRACING (FT)

| CONTINUOUS SHEATHING METHOD: RECTANGLE 1 | |
|--|----------|
| REQUIRED | PROVIDED |
| FRONT | 5.0 |
| RIGHT | 1.4 |
| REAR | 5.0 |
| LEFT | 1.4 |

FIRST FLOOR BRACING (FT)

| ISOLATED PANEL METHOD: RECTANGLE 1 | |
|------------------------------------|----------|
| REQUIRED | PROVIDED |
| FRONT | 3.0 |
| RIGHT | 3.1 |
| REAR | 3.0 |
| LEFT | 3.1 |

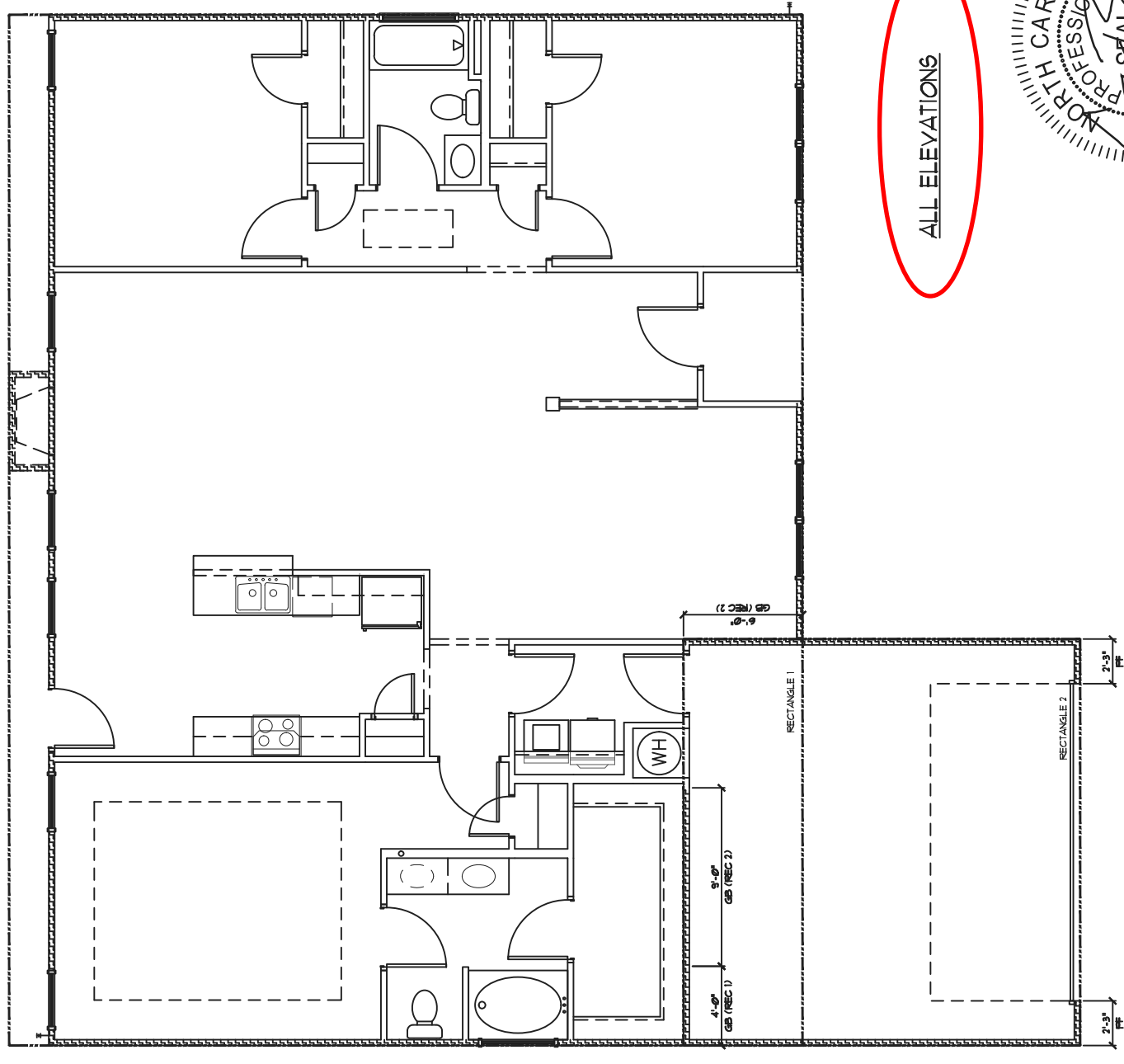

OPT. SIDE ENTRY

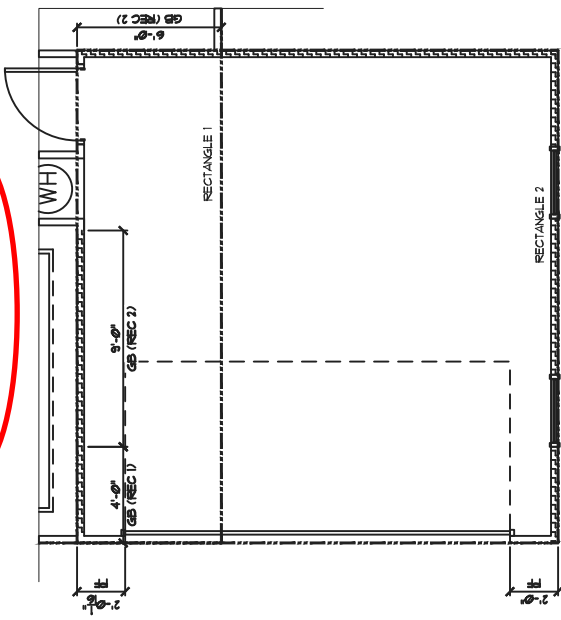

ALL ELEVATIONS

| | | |
|----------|--------|-------------------------|
| DATE | 9/1/16 | UPDATED PER KN REDLINES |
| REVISION | | |
| BY | AW | |

SMITH DOUGLAS HOMES
 110 VILLAGE TRAIL
 SUITE 115
 WOODBRIDGE, VA 20188
 www.smithdouglashomes.com

SMITH DOUGLAS HOMES
 expressly reserves its
 property rights in these plans
 and drawings. These plans
 are to be used for the project
 to be reproduced without
 written consent from SMITH
 DOUGLAS HOMES.

| | |
|--------------|---------|
| DATE: | 6/17/16 |
| PACKAGE QTY: | |
| PLAN ID: | ALL |
| FILE: | ALL |
| PAGE NO.: | D1 |

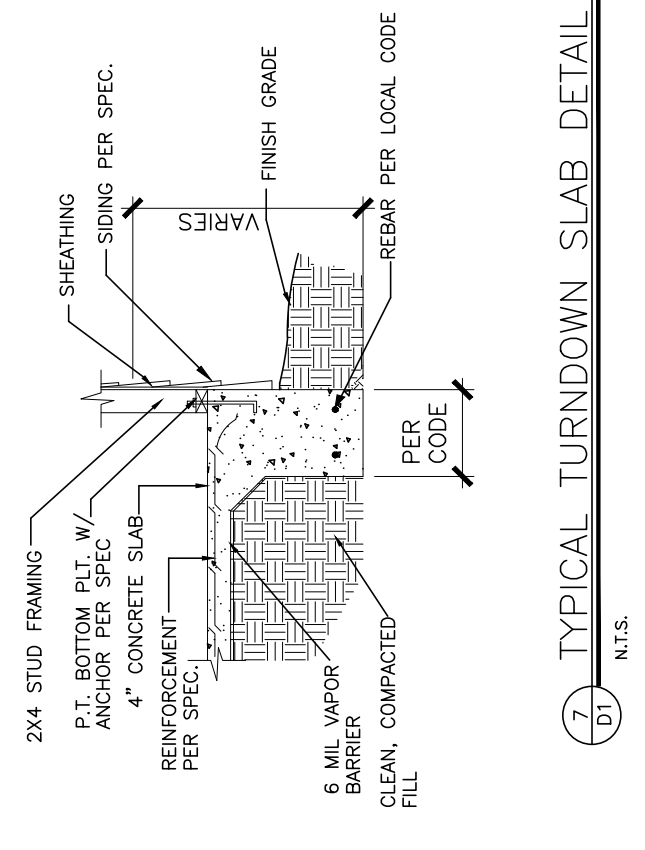
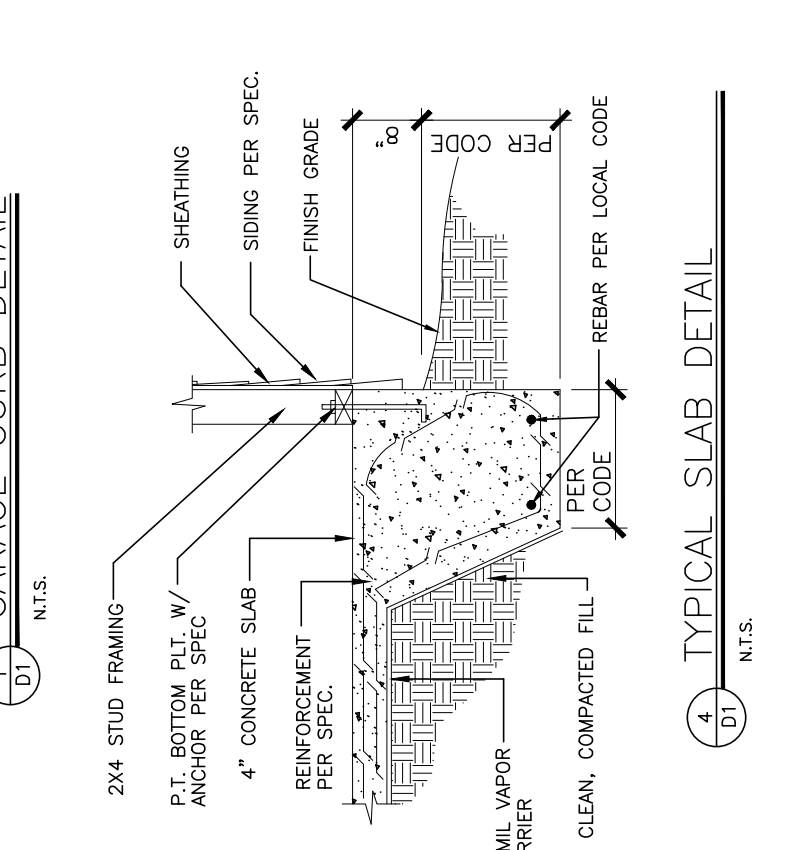
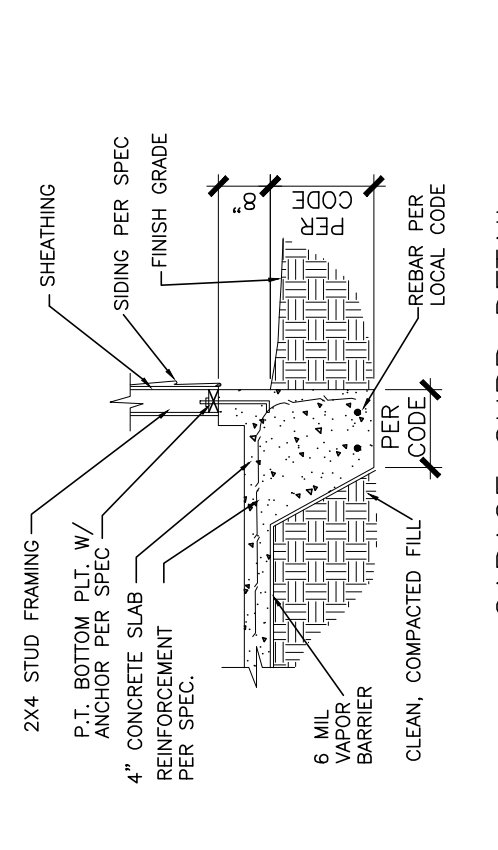
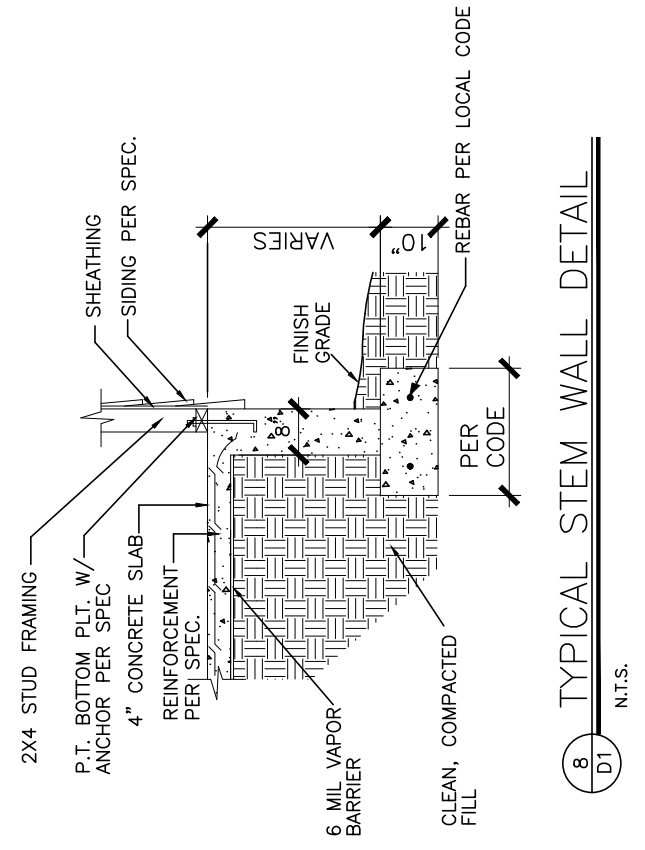
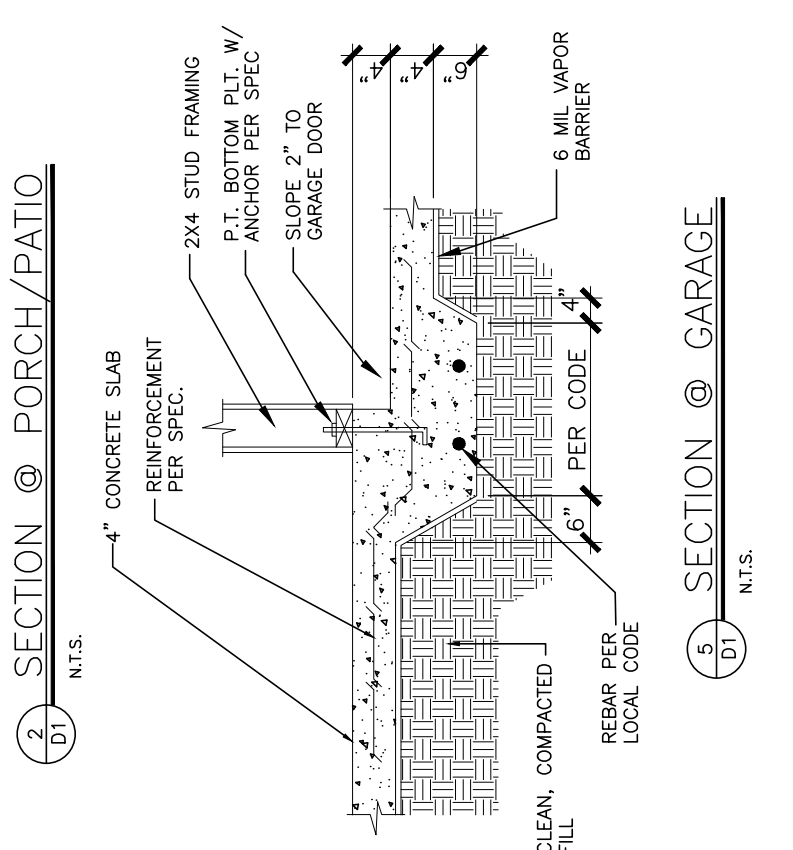
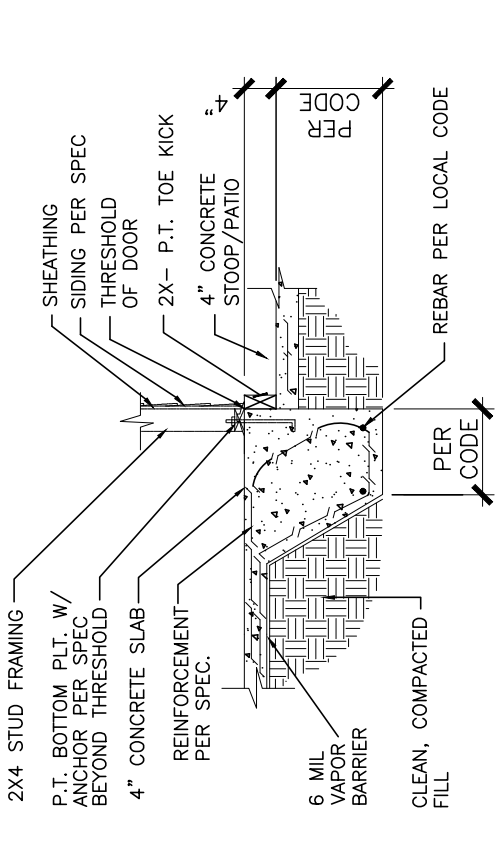
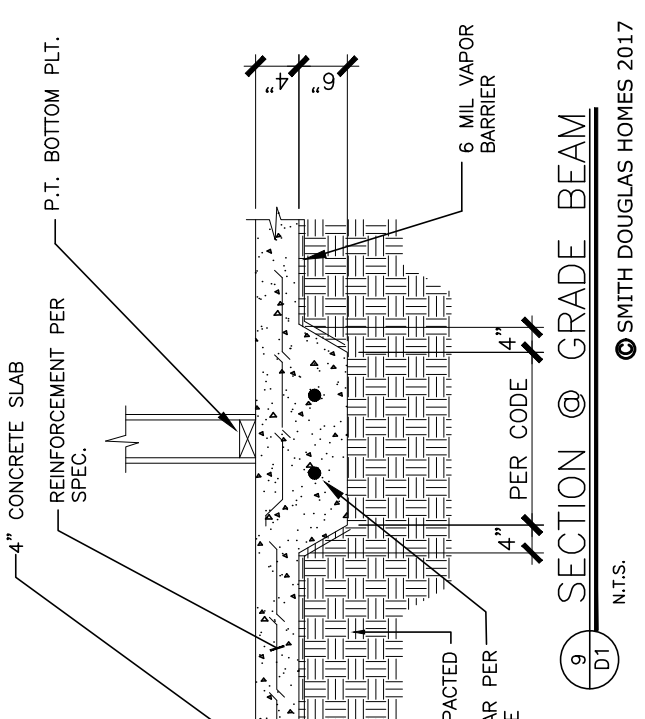
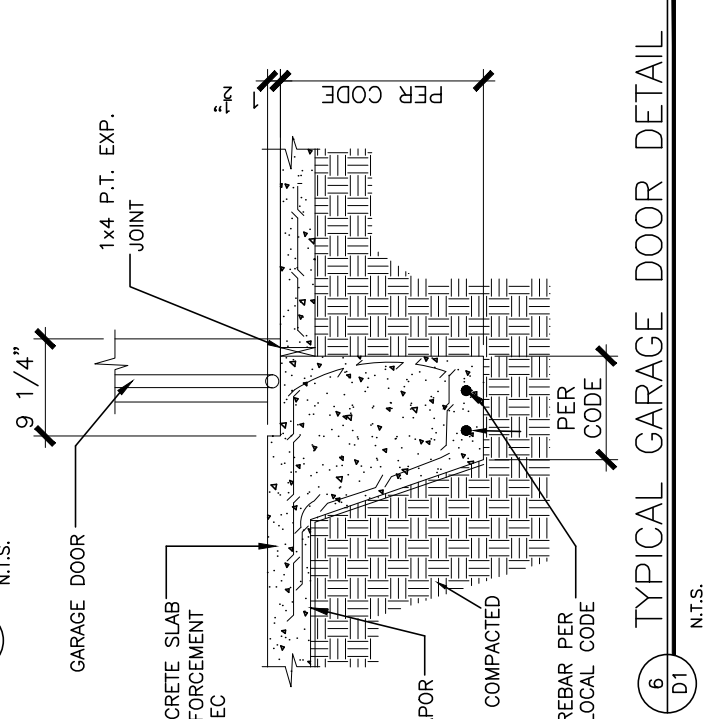
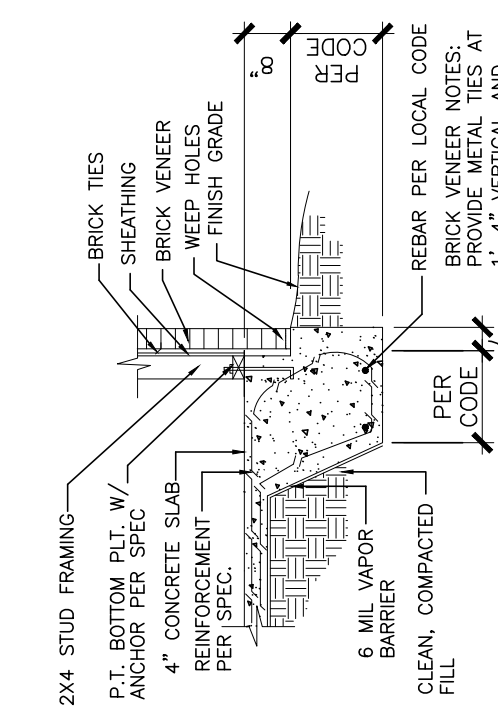

GENERAL STRUCTURAL NOTES:

- The design professional whose seal appears on these drawings is the structural engineer of record (SER) for this project. The SER bears the responsibility of the primary structural elements and the performance of this structure. No other party may revise, alter, or delete any structural aspects of these construction documents without written permission of SUMMIT Engineering, Laboratory & Testing, P.C. (SUMMIT) or the SER. For the purposes of these construction documents the SER and SUMMIT shall be considered the same entity.
- The structure is only stable in its completed form. The contractor shall provide all required temporary bracing during construction to stabilize the structure.
- The SER is not responsible for construction sequences, methods, or techniques in connection with the construction of this structure. The SER will not be held responsible for the contractor's failure to conform to the contract documents, should any non-conformities occur.
- Any structural elements or details not fully developed on the construction drawings shall be completed under the direction of a licensed professional engineer. These shop drawings shall be submitted to SUMMIT for review before any construction begins. The shop drawings will be reviewed for overall compliance as it relates to the structural design of this project. Verification of the shop drawings for dimensions, or for actual field conditions, is not the responsibility of the SER or SUMMIT.
- Verification of assumed field conditions is not the responsibility of the SER. The contractor shall verify the field conditions for accuracy and report any discrepancies to SUMMIT before construction begins.
- The SER is not responsible for any secondary structural elements or non-structural elements, except for the elements specifically noted on the structural drawings.
- This structure and all construction shall conform to all applicable sections of the international residential code.
- This structure and all construction shall conform to all applicable sections of the 2018 North Carolina Residential Code (NCRC) and any local codes or restrictions

FOUNDATIONS:

- Foundations shall be constructed in accordance with chapter 4 of the 2018 NC Residential Building Code (Special consideration shall be given to Chapter 45 in wind zones above 130mph)
- Footing sizes based on a presumptive soil bearing capacity of 2000 PSF. Contractor is solely responsible for verifying the suitability of the site soil conditions at the time of construction
- Maximum depth of unbalanced fill against masonry walls to be as specified in section R404.1 of the 2018 NCRC
- The structural engineer has not performed a subsurface investigation. Verification of this assumed value is the responsibility of the owner or the contractor. Should any adverse soil condition be encountered the SER must be contacted before proceeding.
- The bottom of all footings shall extend below the frost line for the region in which the structure is to be constructed. However, the bottom of all footings shall be a minimum of 12" below grade.
- Any fill shall be placed under the direction or recommendation of a licensed professional engineer. The resulting soil shall be compacted to a minimum of 95% maximum dry density.
- Excavations of footings shall be lined temporarily with a 6 mil polyethylene membrane if placement of concrete does not occur within 24 hours of excavation.
- No concrete shall be placed against any subgrade containing water, ice, frost, or loose material.
- Each crawl space pier shall bear in the middle third of its respective footing and each girder shall bearing in the middle third of the piers. Pilasters to be bonded to perimeter foundation wall
- Crawl spaced to be graded level and clear of all debris
- Provide foundation waterproofing and drain with positive slope to outlet as required by site conditions
- Energy efficiency compliance and insulation of the structure to be in accordance with chapter 11 of the 2018 NCRC

CONCRETE:

- Concrete shall have a normal weight aggregate and a minimum compressive strength (f'c) at 28 days of 3000 psi, unless otherwise noted on the plan.
- Concrete shall be proportioned, mixed, and placed in accordance with the latest editions of ACI 318: "Building Code Requirements for Reinforced Concrete" and ACI 301: "Specifications for Structural Concrete for Buildings".
- Air entrained concrete must be used for all structural elements exposed to freeze/thaw cycles and deicing chemicals. Air entrainment amounts (in percent) shall be within -1% to +2% of target values as follows:
 - Footings: 5%
 - Exterior Slabs: 5%
- No admixtures shall be added to any structural concrete without written permission of the SER
- Concrete slabs-on-grade shall be constructed in accordance with ACI 302.1R-96: "Guide for Concrete Slab and Slab Construction".
- The concrete slab-on-grade has been designed using a subgrade modulus of k=250 pci and a design loading of 200 psf. The SER is not responsible for differential settlement, slab cracking or other future defects resulting from unreported conditions not in accordance with the above assumptions.
- Control or saw cut joints shall be spaced in interior slabs-on-grade at a maximum of 15'-0" O.C. and in exterior slabs-on-grade at a maximum of 10'-0" unless otherwise noted.
- Control or saw cut joints shall be produced using conventional process within 4 to 12 hours after the slab has been finished
- Reinforcing steel may not extend through a control joint. Reinforcing steel may extend through a saw cut joint.
- All welded wire fabric (W.W.F.) for concrete slabs-on-grade shall be placed at mid-depth of slab. The W.W.F. shall be securely supported during the concrete pour. Fibermesh may be used in lieu of W.W.F.

CONCRETE REINFORCEMENT:

- Fibrous concrete reinforcement, or fibermesh, specified in concrete slabs-on-grade may be used for control of cracking due to shrinkage and thermal expansion/contraction, lowered water migration, an increase in impact capacity, increased abrasion resistance, and residual strength.
- Fibermesh reinforcing to be 100% virgin polypropylene fibers containing no reprocessed olefin materials and specifically manufactured for use as concrete secondary reinforcement.
- Application of fibermesh per cubic yard of concrete shall equal a minimum of 0.1% by volume (1.5 pounds per cubic yard)
- Fibermesh shall comply with ASTM C1116, any local building code requirements, and shall meet or exceed the current industry standard.
- Steel Reinforcing bars shall be new billet steel conforming to ASTM A615, grade 60.
- Detailing, fabrication, and placement of reinforcing steel shall be in accordance with the latest edition of ACI 315: "Manual of Standard Practice for Detailing Concrete Structures"
- Horizontal footing and wall reinforcement shall be continuous and shall have 90° bends, or corner bars with the same size/spacing as the horizontal reinforcement with a class B tension splice.
- Lap reinforcement as required, a minimum of 40 bar diameters for tension or compression unless otherwise noted. Splices in masonry shall be a minimum of 48 bar diameters.
- Where reinforcing dowels are required, they shall be equivalent in size and spacing to the vertical reinforcement. The dowel shall extend 48 bar diameters vertically and 20 bar diameters into the footing.
- Where reinforcing steel is required vertically, dowels shall be provided unless otherwise noted.

WOOD FRAMING:

- Solid sawn wood framing members shall conform to the specifications listed in the latest edition of the "National Design Specification for Wood Construction" (NDS). Unless otherwise noted, all wood framing members are designed to be Spruce-Pine-Fir (SPF) #2.
- LVL or PSL engineered wood shall have the following minimum design values:
 - E = 1,900,000 psi
 - Fb = 2600 psi
 - Fv = 285 psi
 - Fc = 700 psi
- Wood in contact with concrete, masonry, or earth shall be pressure treated in accordance with AWPA standard C-15. All other moisture exposed wood shall be treated in accordance with AWPA standard C-2
- Nails shall be common wire nails unless otherwise noted.
- Lag screws shall conform to ANSI/ASME standard B18.2.1-1981. Lead holes for lag screws shall be in accordance with NDS specifications.
- All beams shall have full bearing on supporting framing members unless otherwise noted.
- Exterior and load bearing stud walls are to be 2x4 SPF#2 @16" O.C. unless otherwise noted. Studs shall be continuous from the sole plate to the double top plate. Studs shall only be discontinuous at headers for window/door openings. A minimum of one king stud shall be placed at each end of the header. King studs shall be continuous.
- Individual studs forming a column shall be attached with one 10d nail @6" O.C. staggered. The stud column shall be continuous to the foundation or beam. The column shall be fully blocked at all floor levels to ensure proper load transfer.
- Multi-ply beams shall have each ply attached with (3)10d nails @ 24" O.C.
- Fitch beams and four and five ply beams shall be bolted together with (2) rows of 1/2" dia. through bolts staggered @24" O.C. w/ 2" edge distance and (2) bolts located at 6" from each end, unless noted otherwise.

WOOD TRUSSES:

- The wood truss manufacturer/fabricator is responsible for the design of the wood trusses. Submit sealed shop drawings and supporting calculations to the SER for review prior to fabrication. The SER shall have a minimum of five (5) days for review. The review by the SER shall review for overall compliance with the design documents. The SER shall assume no responsibility for the correctness for the structural design for the wood trusses.
- The wood trusses shall be designed for all required loadings as specified in the local building code, the ASCE Standard "Minimum Design Loads for Buildings and Other Structures." (ASCE 7-10), and the loading requirements shown on these specifications. The truss drawings shall be coordinated with all other construction documents and provisions provided for loads shown on these drawings including but not limited to HVAC equipment, piping, and architectural fixtures attached to the trusses.
- The trusses shall be designed, fabricated, and erected in accordance with the latest edition of the "National Design Specification for Wood Construction." (NDS) and "Design Specification for Metal Plate Connected Wood Trusses."
- The truss manufacturer shall provide adequate bracing information in accordance with "Commentary and Recommendations for Handling, Installing, and Bracing Metal Plate Connected Wood Trusses" (HIB-91). This bracing, both temporary and permanent, shall be shown on the shop drawings. Also, the shop drawings shall show the required attachments for the trusses.
- Any chords or truss webs shown on these drawings have been shown as a reference only. The final design of the trusses shall be per the manufacturer.

WOOD STRUCTURAL PANELS:

- Fabrication and placement of structural wood sheathing shall be in accordance with the APA Design/Construction Guide "Residential and Commercial," and all other applicable APA standards.
- All structurally required wood sheathing shall bear the mark of the APA.
- Wood wall sheathing shall comply with the requirements of local building codes for the appropriate state as indicated on these drawings. Refer to wall bracing notes in plan set for more information. Sheathing shall be applied with the long direction perpendicular to framing, unless noted otherwise.
- Roof sheathing shall be APA rated sheathing exposure 1 or 2. Roof sheathing shall be continuous over two supports and attached to its supporting roof framing with (1)-8d CC nail at 6"o/c at panel edges and at 12"o/c in panel field unless otherwise noted on the plans. Sheathing shall be applied with the long direction perpendicular to framing. Sheathing shall have a span rating consistent with the framing spacing. Use suitable edge support by use of plywood clips or lumber blocking unless otherwise noted. Panel end joints shall occur over framing. Apply building paper over the sheathing as required by the state Building Code.
- Wood floor sheathing shall be APA rated sheathing exposure 1 or 2. Attach sheathing to its supporting framing with (1)-8d CC ringshank nail at 6"o/c at panel edges and at 12"o/c in panel field unless otherwise noted on the plans. Sheathing shall be applied perpendicular to framing. Sheathing shall have a span rating consistent with the framing spacing. Use suitable edge support by use of T&G plywood or lumber blocking unless otherwise noted. Panel end joints shall occur over framing. Apply building paper over the sheathing as required by the state Building Code.
- Sheathing shall have a 1/8" gap at panel ends and edges as recommended in accordance with the APA.

STRUCTURAL FIBERBOARD PANELS:

- Fabrication and placement of structural fiberboard sheathing shall be in accordance with the applicable AFA standards.
- Fiberboard wall sheathing shall comply with the requirements of local building codes for the appropriate state as indicated on these drawings. Refer to wall bracing notes in plan set for more information.
- Sheathing shall have a 1/8" gap at panel ends and edges are recommended in accordance with the AFA.

EXTERIOR WOOD FRAMED DECKS:

- Decks are to be framed in accordance with local building codes and as referenced on the structural plans, either through code references or construction details.

STRUCTURAL STEEL:

- Structural steel shall be fabricated and erected in accordance with the American Institute of Steel Construction "Code of Standard Practice for Steel Buildings and Bridges" and of the manual of Steel Construction "Load Resistance Factor Design" latest editions.
- All steel shall have a minimum yield stress (Fy) of 36 ksi unless otherwise noted.
- Welding shall conform to the latest edition of the American Welding Society's Structural Welding Code AWS D1.1. Electrodes for shop and field welding shall be class E70XX. All welding shall be performed by a certified welder per the above standards.

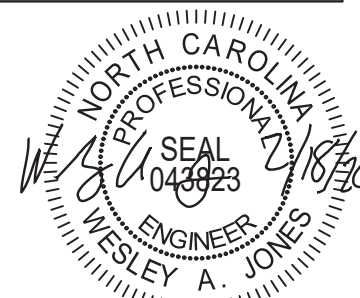

STRUCTURAL MEMBERS ONLY

SUMMIT
ENGINEERING LABORATORY TESTING
3070 HAMMOND BUSINESS PLACE,
SUITE 171, RALEIGH, NC 27603
OFFICE: 919.380.9991
FAX: 919.380.9993
WWW.SUMMIT-COMPANIES.COM

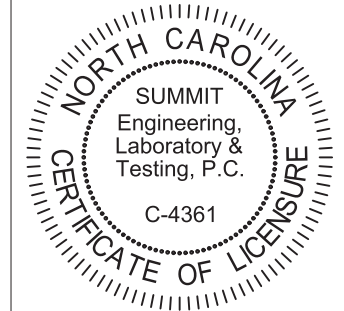

PROJECT
Standard Details
Notes and Specifications
CLIENT
Smith Douglas Homes
110 Village Trail, Suite 215
Woodstock, GA 30188

CURRENT DRAWING

DATE: 2/18/20
SCALE: NTS
PROJECT #: 3832
DRAWN BY: LBV
CHECKED BY: WAJ

ORIGINAL DRAWING

| NO. | DATE | PROJECT # |
|-----|--------|-----------|
| 0 | 1/7/16 | 3832 |

REFER TO COVER SHEET FOR A COMPLETE LIST OF REVISIONS

SHEET

CS2

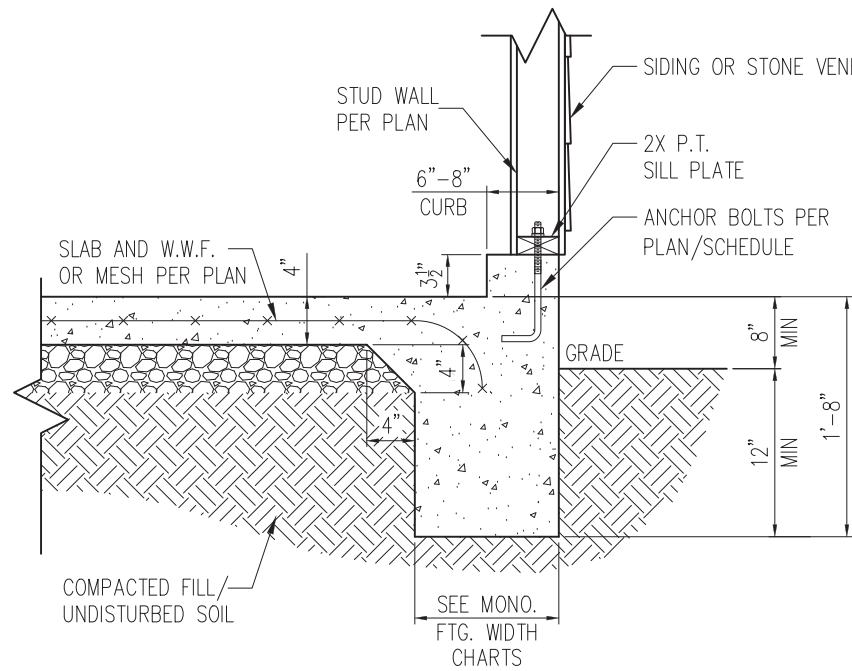

STANDARD - SIDING/STONE

1 TYP. GARAGE CURB DETAIL
D1m 3/4" = 1'-0"

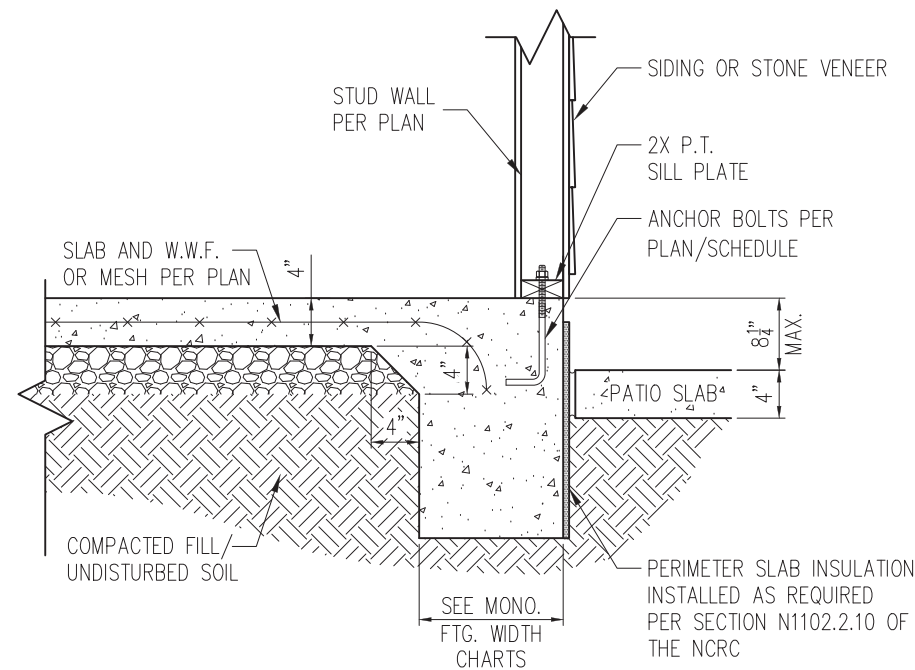

STANDARD - SIDING/STONE

2 PATIO SLAB DETAIL
D1m 3/4" = 1'-0"

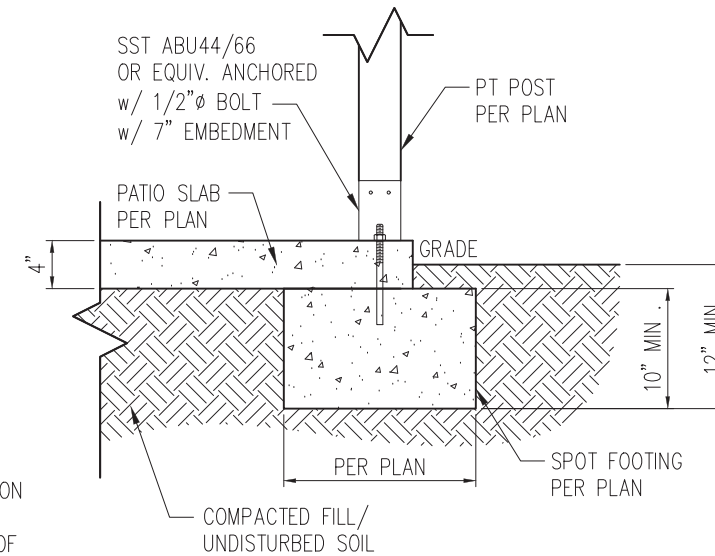

2A COVERED PATIO DETAIL
D1m 3/4" = 1'-0"

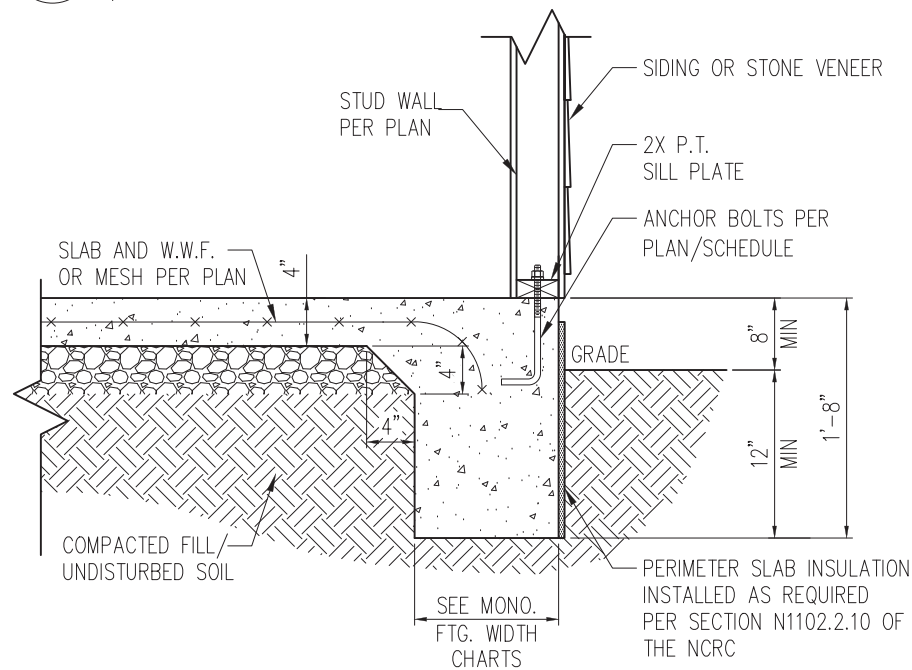

STANDARD - SIDING/STONE

3 TYP. SLAB DETAIL
D1m 3/4" = 1'-0"

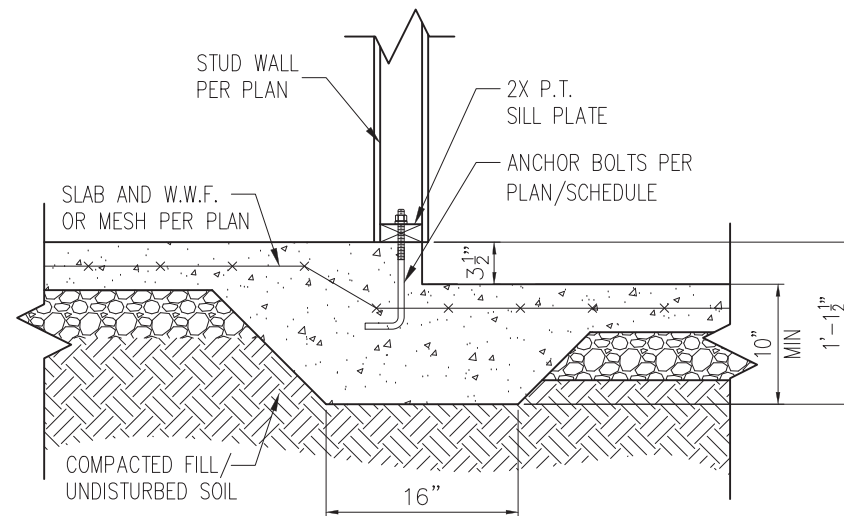

4 STEP IN GARAGE
D1m 3/4" = 1'-0"

WALL ANCHOR SCHEDULE

| TYPE OF ANCHOR | MIN. CONC. EMBEDMENT | SPACING EMBEDMENT | INTERIOR WALL | EXTERIOR WALL |
|---|----------------------|-------------------|---------------|---------------|
| 1/2" Ø A307 BOLTS w/ STD. 90° BEND | 7" | 6'-0" | YES | YES |
| SST - MAS | 4" | 5'-0" | NO | YES |
| HILTI KWIK BOLT KBI 1/2-2-3/4 | 2-1/4" | 6'-0" | YES | NO |
| 1/2" Ø HILTI THREADED ROD w/ HIT HY150 ADHESIVE | 7" | 6'-0" | YES | YES |

NOTE: INSTALL ALL ANCHORS 12" MAX. FROM ALL BOTTOM PLATE ENDS AND JOINTS.

MONOLITHIC FOOTING WIDTH

| # OF STORIES | WIDTH BASED ON SOIL BEARING CAPACITY | | |
|------------------------|--------------------------------------|----------|----------|
| | 1500 PSF | 2000 PSF | 2500 PSF |
| 1 STORY - STD. | 16" | 16" | 16" |
| 1 STORY - BRICK VENEER | 21" | 21" | 21" |
| 2 STORY - STD. | 20" | 16" | 16" |
| 2 STORY - BRICK VENEER | 25" | 21" | 21" |

*5" BRICK LEDGE HAS BEEN ADDED TO THE MONOLITHIC FOOTING WIDTH FOR BRICK SUPPORT

- NOTES:
- REFER TO GENERAL NOTES & SPECIFICATIONS ON SHEET CS2 FOR ADDITIONAL INFORMATION.
 - PROVIDE 6 MIL VAPOR BARRIER UNDER ALL SLABS-ON-GRADE.
 - SEE ARCH. DWGS. FOR ALL TOP OF THE SLAB ELEVATIONS, SLOPES AND DEPRESSIONS.

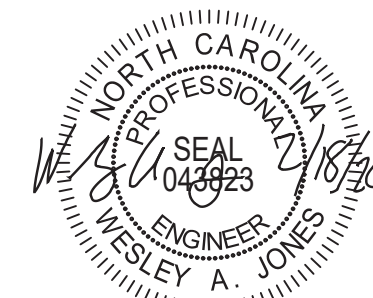

STRUCTURAL MEMBERS ONLY

SUMMIT
ENGINEERING LABORATORY TESTING
3070 HAMMOND BUSINESS PLACE,
SUITE 171, RALEIGH, NC 27603
OFFICE: 919.380.9991
FAX: 919.380.9993
WWW.SUMMIT-COMPANIES.COM

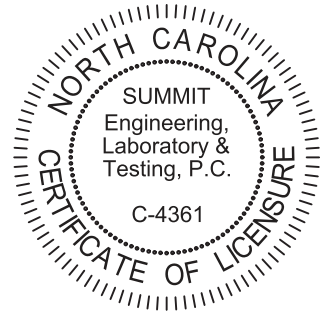

PROJECT
Standard Details
Monolithic Slab Details
CLIENT
Smith Douglas Homes
110 Village Trail, Suite 215
Woodstock, GA 30188

CURRENT DRAWING
DATE: 2/18/20
SCALE: NTS
PROJECT #: 3832
DRAWN BY: LBV
CHECKED BY: WAJ

ORIGINAL DRAWING
NO. DATE PROJECT #
0 1/7/16 3832

REFER TO COVER SHEET FOR A COMPLETE LIST OF REVISIONS

SHEET

D1m

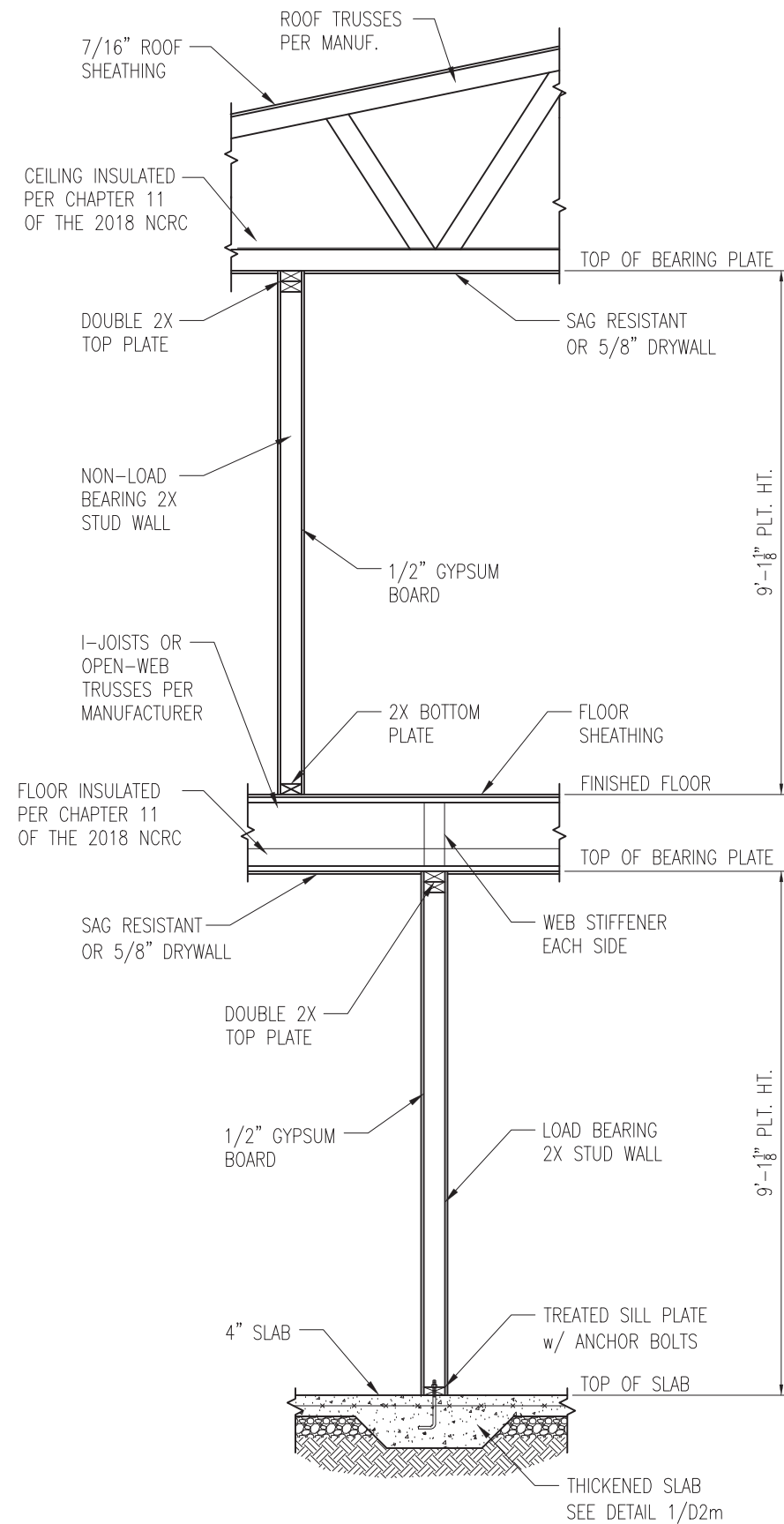

1 TYP. INTERIOR LOAD BEARING WALL SECTION
 D3m 3/4" = 1'-0"

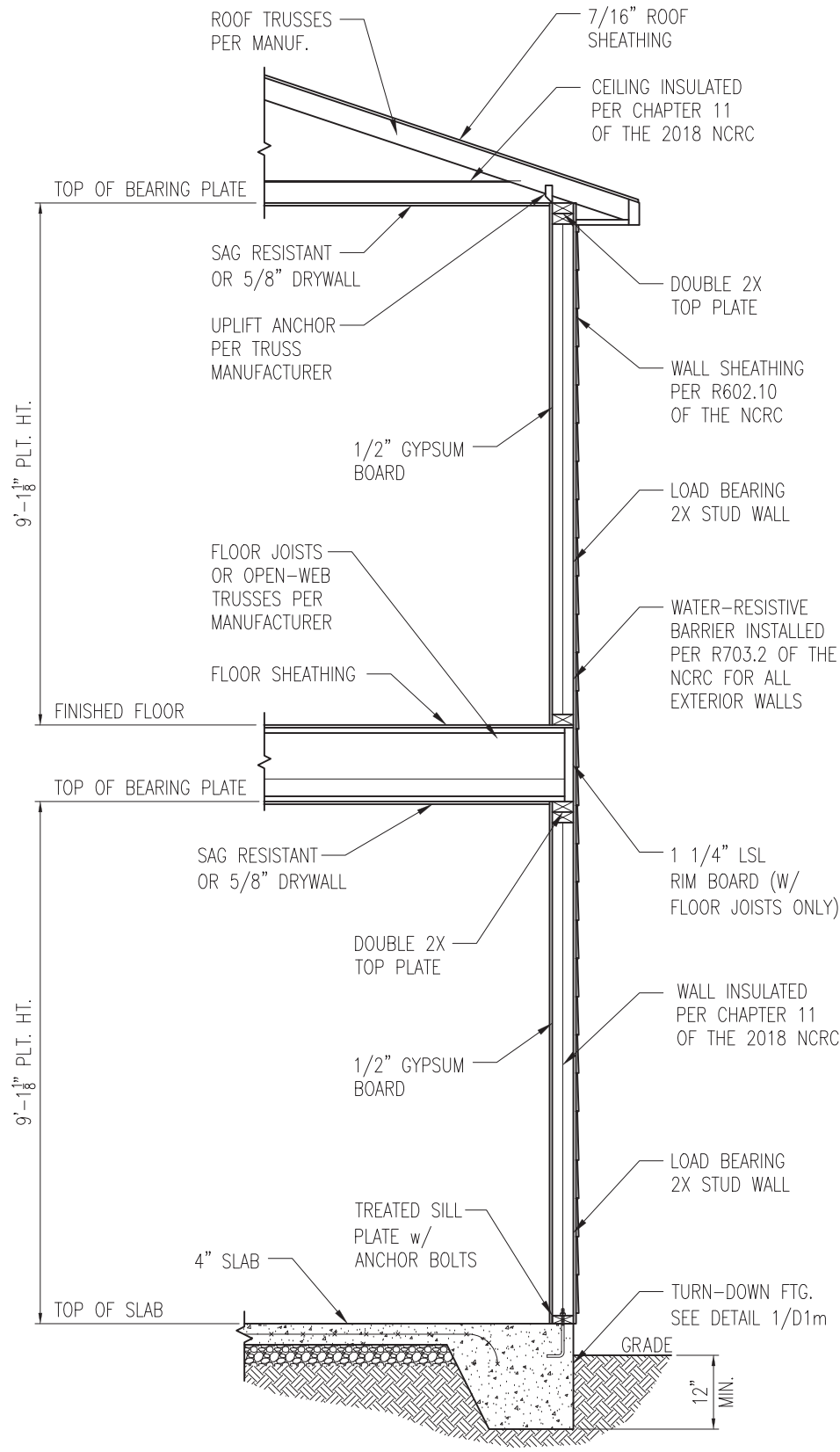

2 TYP. EXTERIOR LOAD BEARING WALL SECTION
 D3m 3/4" = 1'-0"
 -SIMILAR w/ BRICK AND STONE
 -BRICK TIES SPACED @ 16" O.C. HORIZ. & 24" O.C. VERT.
 -MIN. 3/16" Ø WEEP HOLES @ 33" O.C.

- NOTES:
1. REFER TO GENERAL NOTES & SPECIFICATIONS ON SHEET CS2 FOR ADDITIONAL INFORMATION.
 2. PROVIDE 6 MIL VAPOR BARRIER UNDER ALL SLABS-ON-GRADE.
 3. SEE ARCH. DWGS. FOR ALL TOP OF THE SLAB ELEVATIONS, SLOPES AND DEPRESSIONS.



STRUCTURAL MEMBERS ONLY

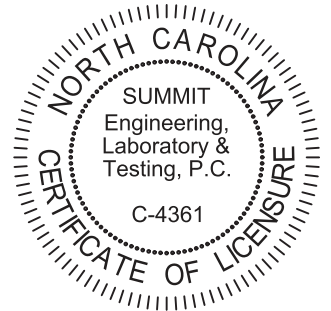

PROJECT
Standard Details
Monolithic Slab Details
 CLIENT
Smith Douglas Homes
 110 Village Trail, Suite 215
 Woodstock, GA 30188

CURRENT DRAWING
 DATE: 2/18/20
 SCALE: NTS
 PROJECT #: 3832
 DRAWN BY: LBV
 CHECKED BY: WAJ

ORIGINAL DRAWING
 NO. DATE PROJECT #
 0 1/7/16 3832

REFER TO COVER SHEET FOR A COMPLETE LIST OF REVISIONS

SHEET
D3m

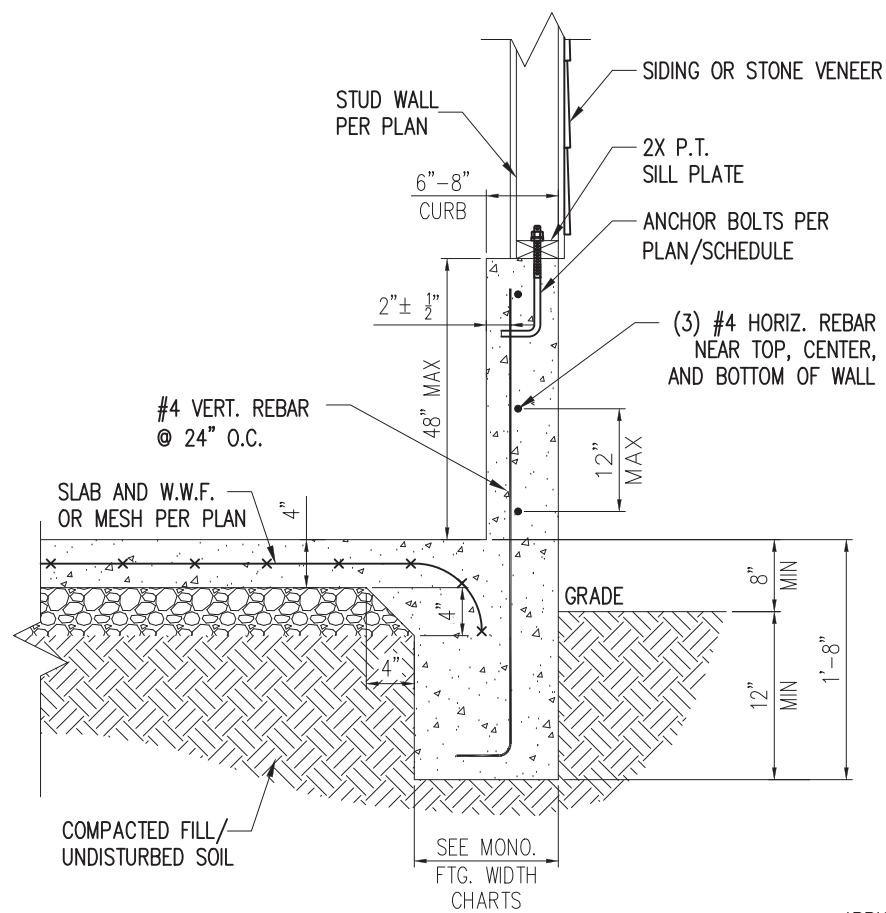

STANDARD - SIDING/STONE

1 EXTENDED GARAGE CURB DETAIL
D4m NTS

*BRICK TIES SPACED @
16" O.C. HORIZ. & 24" O.C.
VERT. AND 3/16" Ø WEEP
HOLES @ 33" O.C.

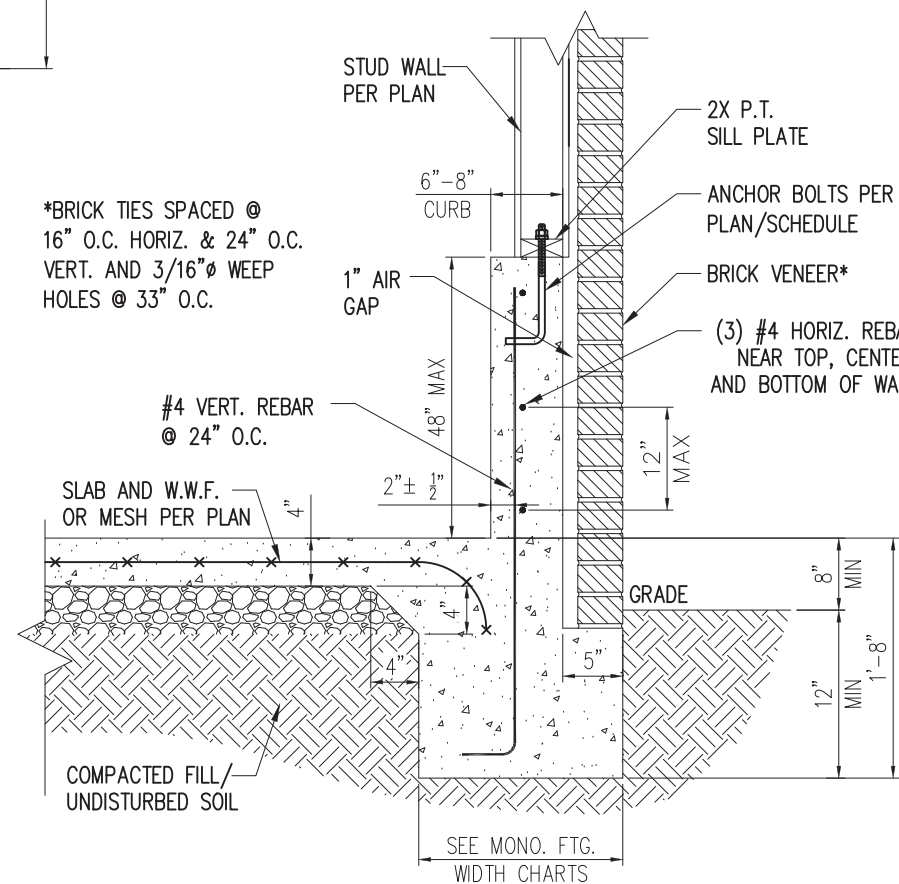

STANDARD - BRICK

3 EXTENDED GARAGE CURB DETAIL
W/ BRICK VENEER
D4m NTS

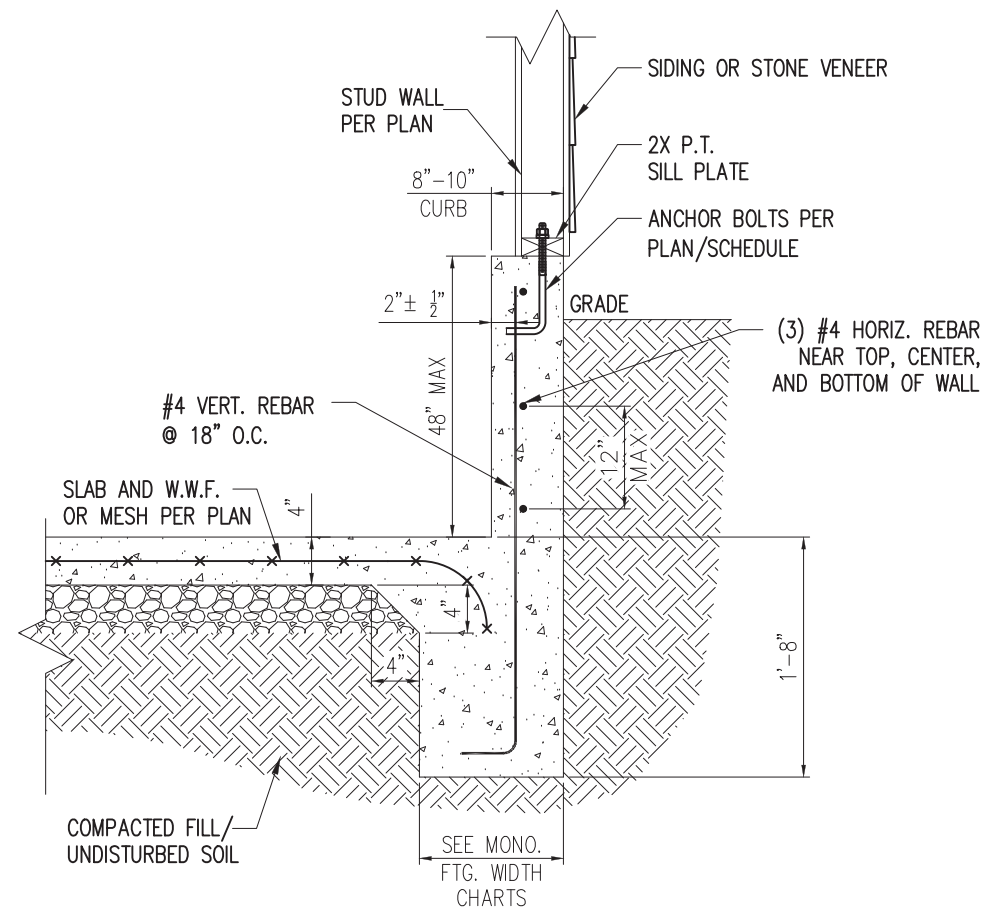

STANDARD - SIDING/STONE

2 EXTENDED GARAGE CURB DETAIL
W/ UNBALANCED FILL
D4m NTS

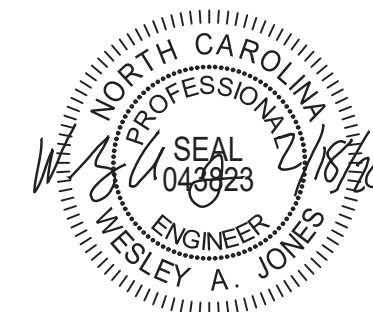

STRUCTURAL MEMBERS ONLY

SUMMIT
ENGINEERING LABORATORY TESTING
3070 HAMMOND BUSINESS PLACE,
SUITE 171, RALEIGH, NC 27603
OFFICE: 919.380.9991
FAX: 919.380.9993
WWW.SUMMIT-COMPANIES.COM

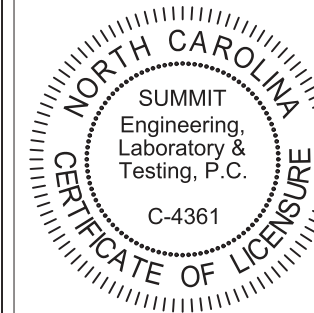

PROJECT
Standard Details
Monolithic Slab Details
CLIENT
Smith Douglas Homes
110 Village Trail, Suite 215
Woodstock, GA 30188

CURRENT DRAWING
DATE: 2/18/20
SCALE: NTS
PROJECT #: 3832
DRAWN BY: LBV
CHECKED BY: WAJ

ORIGINAL DRAWING
NO. DATE PROJECT #
0 1/7/16 3832

REFER TO COVER SHEET FOR A
COMPLETE LIST OF REVISIONS

SHEET

D4m

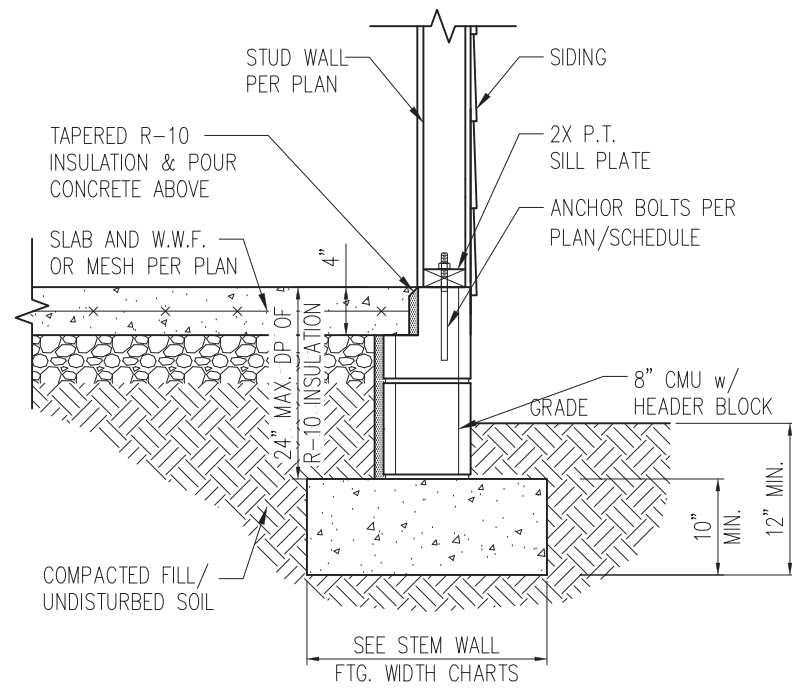

STANDARD - SIDING

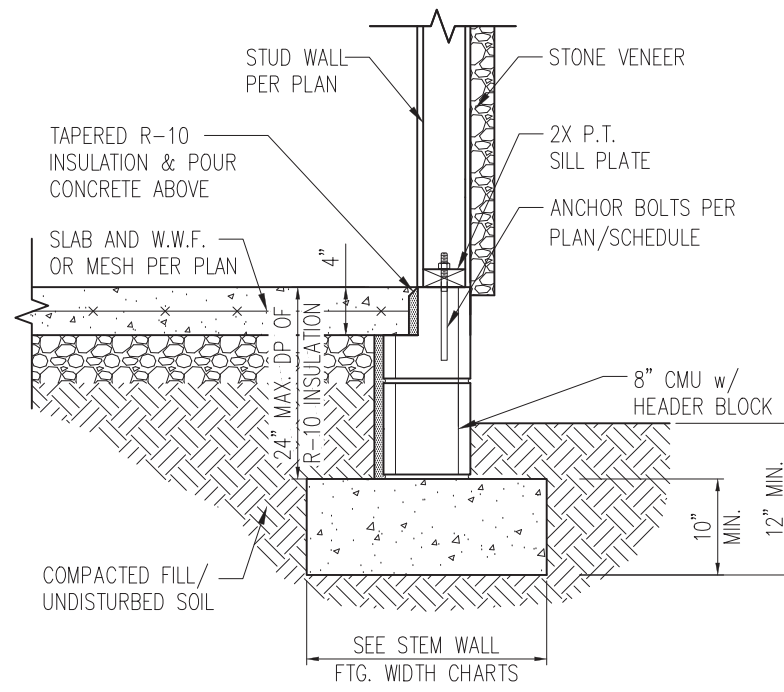

STANDARD - STONE

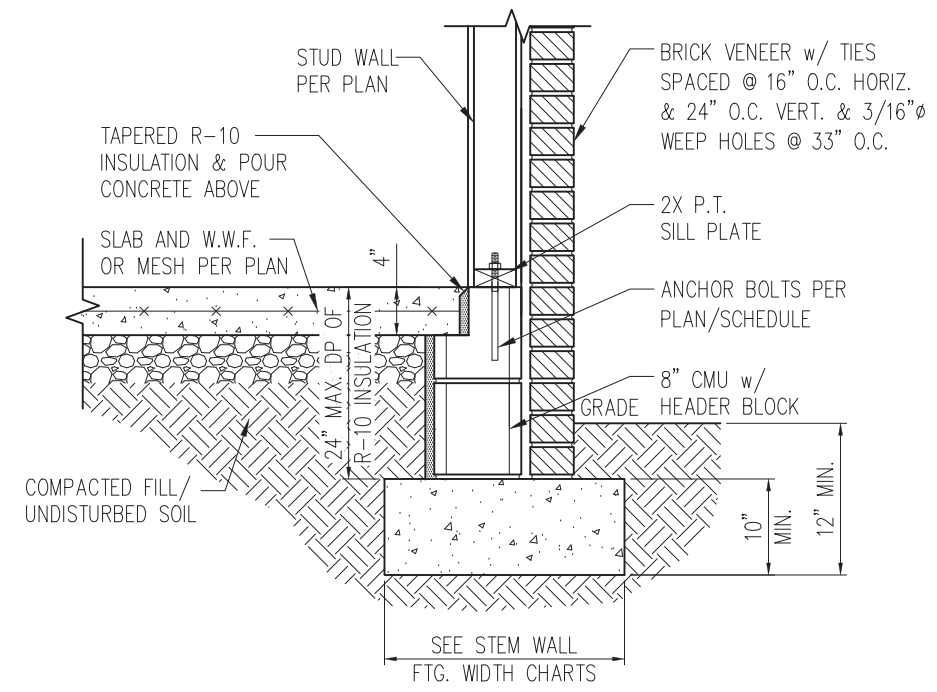

STANDARD - BRICK

1 TYP. STEM WALL DETAIL
D1s 3/4" = 1'-0"

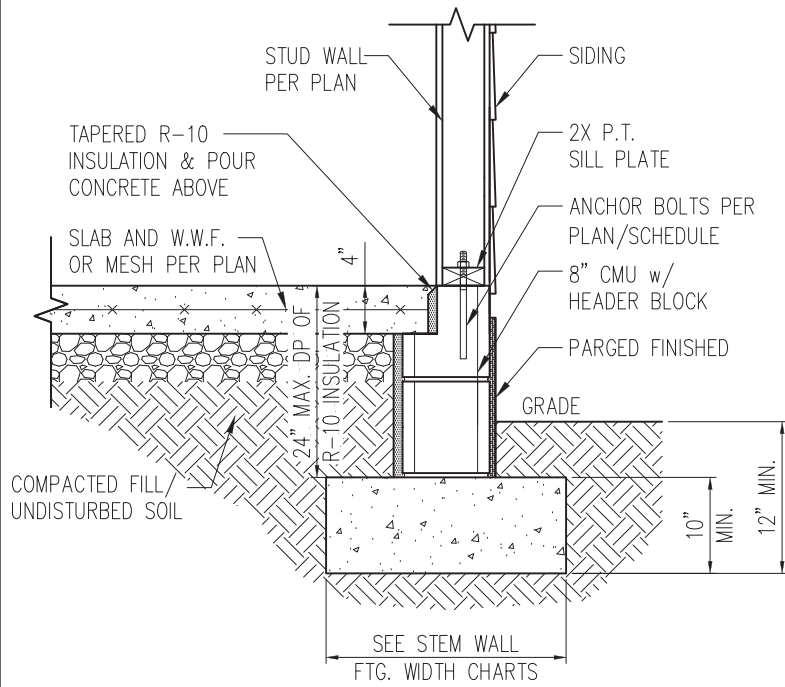

STANDARD - SIDING

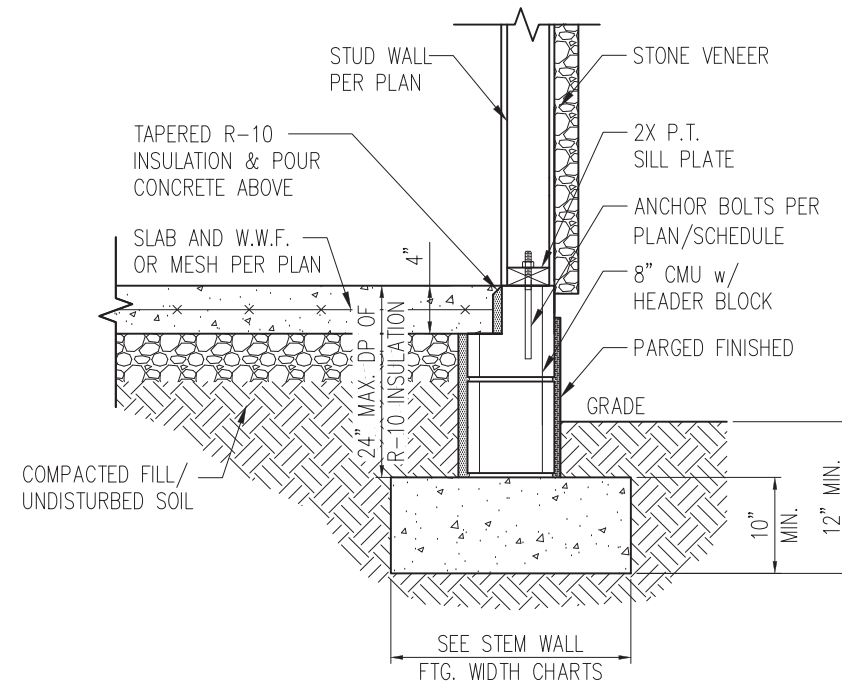

STANDARD - STONE

1a STEM WALL DETAIL w/ PARGED FINISH
D1s 3/4" = 1'-0"

STEM WALL FOOTING WIDTH

| # OF STORIES | WIDTH BASED ON SOIL BEARING CAPACITY | | |
|------------------------|--------------------------------------|----------|----------|
| | 1500 PSF | 2000 PSF | 2500 PSF |
| 1 STORY - STD. | 16" | 16" | 16" |
| 1 STORY - BRICK VENEER | 21"* | 21"* | 21"* |
| 2 STORY - STD. | 20" | 16" | 16" |
| 2 STORY - BRICK VENEER | 25"* | 21"* | 21"* |

*5" BRICK LEDGE HAS BEEN ADDED TO THE STEM WALL FOOTING WIDTH FOR BRICK SUPPORT

WALL ANCHOR SCHEDULE

| TYPE OF ANCHOR | MIN. CONC. EMBEDMENT | SPACING EMBEDMENT | INTERIOR | EXTERIOR |
|---|----------------------|-------------------|----------|----------|
| | | | WALL | WALL |
| 1/2" A307 BOLTS w/ STD. 90° BEND | 7" | 6'-0" | YES | YES |
| SST - MAS | 4" | 5'-0" | NO | YES |
| HILTI KWIK BOLT KBI 1/2-2-3/4 | 2-1/4" | 6'-0" | YES | NO |
| 1/2" HILTI THREADED ROD w/ HIT HY150 ADHESIVE | 7" | 6'-0" | YES | YES |

NOTE: INSTALL ALL ANCHORS 12" MAX. FROM ALL BOTTOM PLATE ENDS AND JOINTS.

NOTES:

- REFER TO GENERAL NOTES & SPECIFICATIONS ON SHEET CS2 FOR ADDITIONAL INFORMATION.
- PROVIDE 6 MIL VAPOR BARRIER UNDER ALL SLABS-ON-GRADE.
- SEE ARCH. DWGS. FOR ALL TOP OF THE SLAB ELEVATIONS, SLOPS AND DEPRESSIONS.

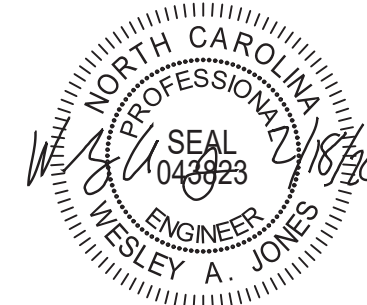

STRUCTURAL MEMBERS ONLY

SUMMIT
ENGINEERING LABORATORY TESTING
3070 HAMMOND BUSINESS PLACE,
SUITE 171, RALEIGH, NC 27603
OFFICE: 919.380.9991
FAX: 919.380.9993
WWW.SUMMIT-COMPANIES.COM

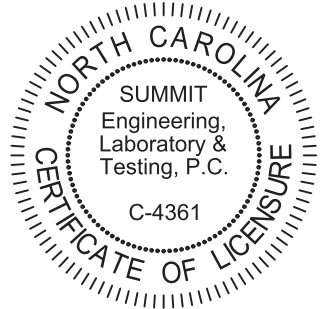

PROJECT
Standard Details
Stemwall Details
CLIENT
Smith Douglas Homes
110 Village Trail, Suite 215
Woodstock, GA 30188

CURRENT DRAWING
DATE: 2/18/20
SCALE: NTS
PROJECT #: 3832
DRAWN BY: LBV
CHECKED BY: WAJ

ORIGINAL DRAWING
NO. DATE PROJECT #
0 1/7/16 3832

REFER TO COVER SHEET FOR A COMPLETE LIST OF REVISIONS

SHEET

D1s

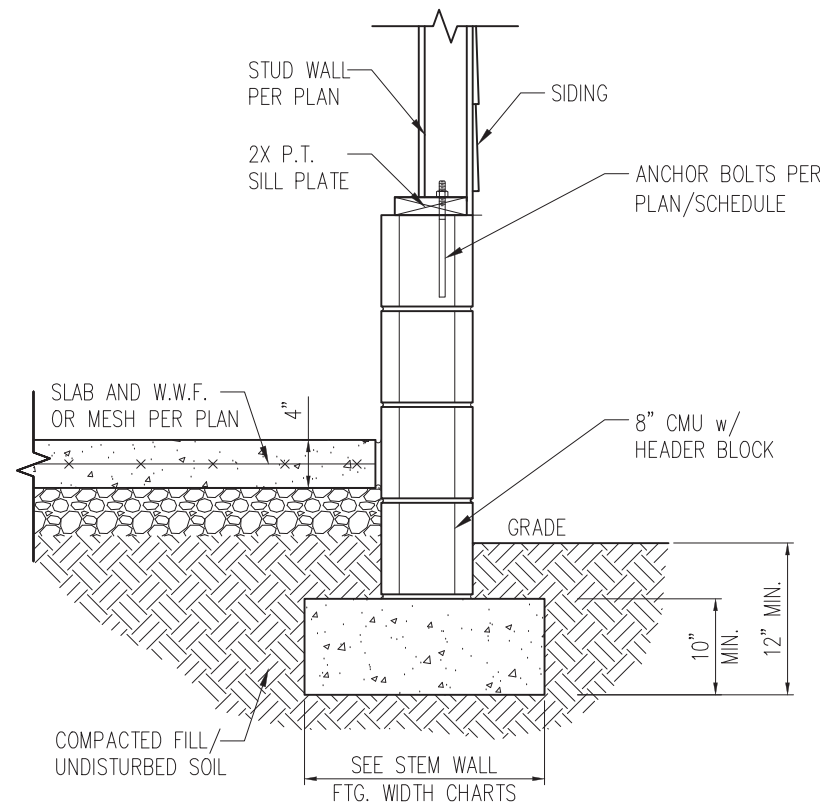

STANDARD – SIDING

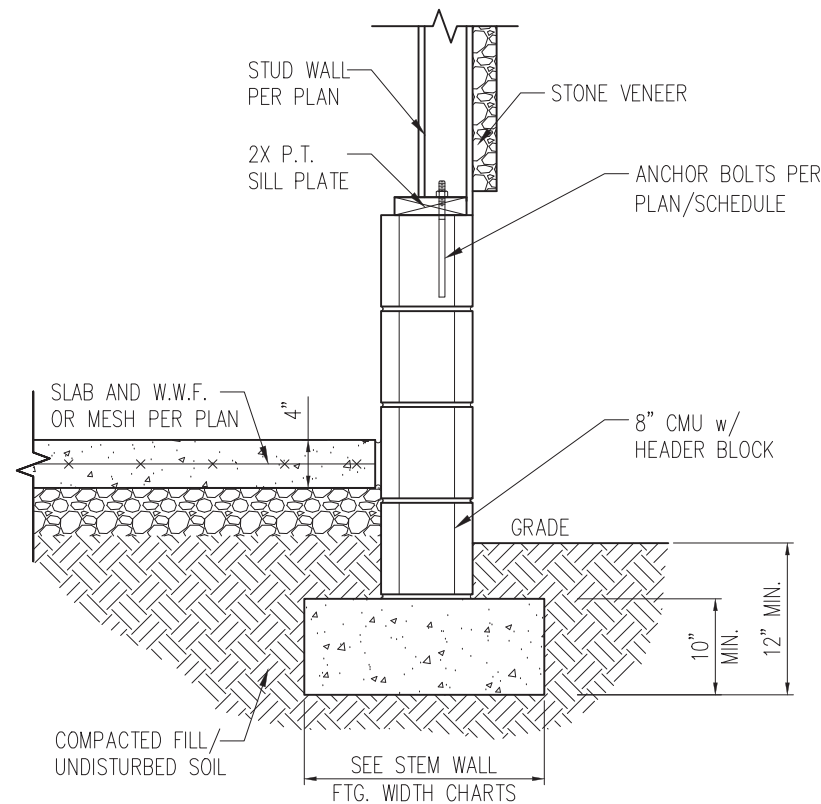

STANDARD – STONE

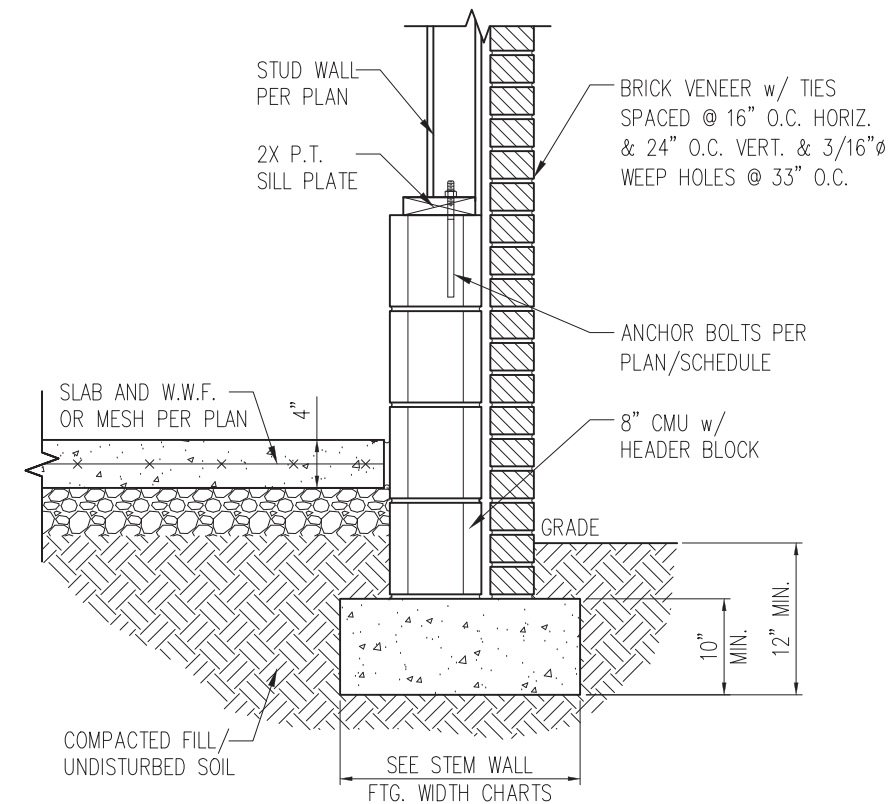

STANDARD – BRICK

1 TYP. GARAGE CURB DETAIL
D2s 3/4" = 1'-0"

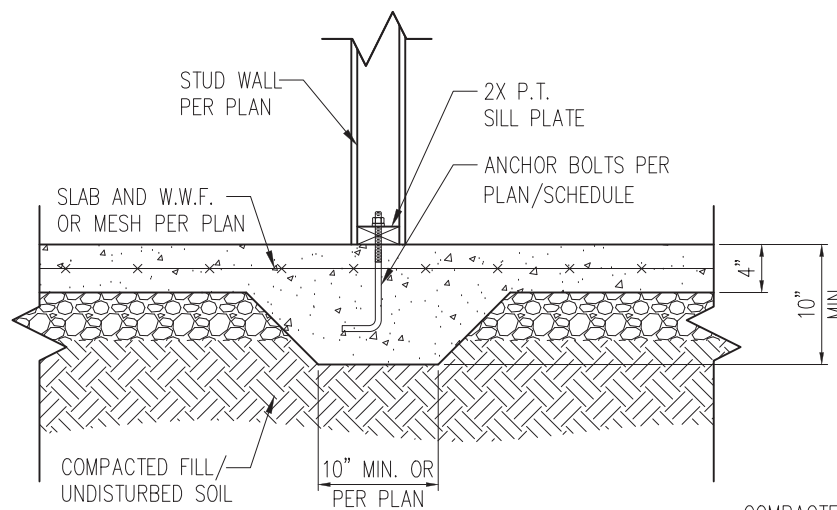

2 TYP. THICKENED SLAB DETAIL
D2s 3/4" = 1'-0"

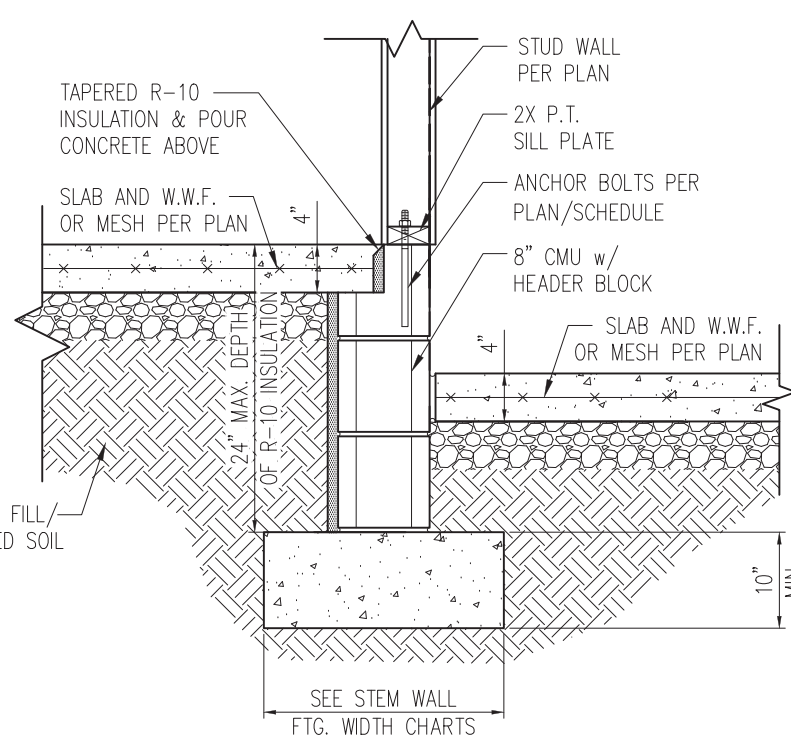

3 HOUSE/GARAGE WALL DETAIL
D2s 3/4" = 1'-0"

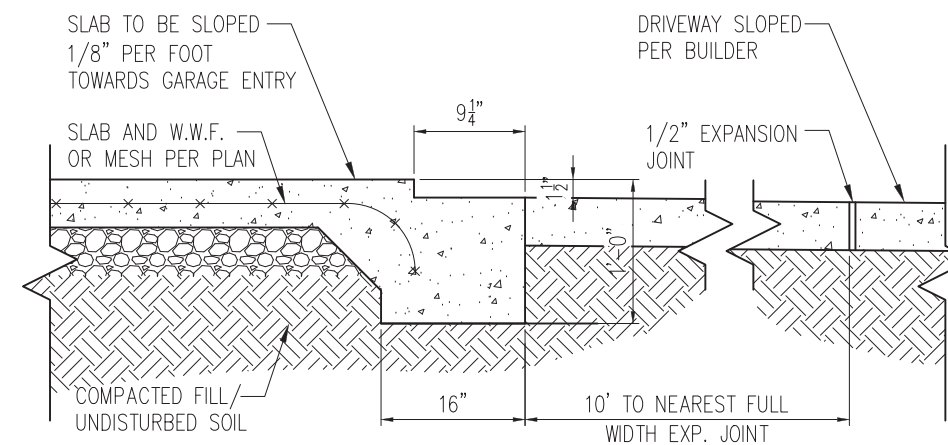

4 SLAB AT GARAGE DOOR
D2s 3/4" = 1'-0"

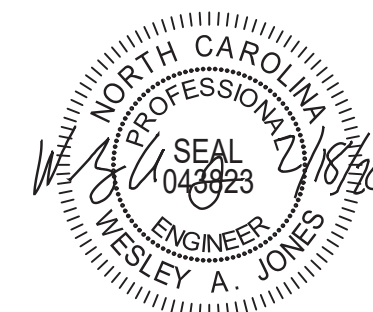

STRUCTURAL MEMBERS ONLY

SUMMIT
ENGINEERING LABORATORY TESTING
3070 HAMMOND BUSINESS PLACE,
SUITE 171, RALEIGH, NC 27603
OFFICE: 919.380.9991
FAX: 919.380.9993
WWW.SUMMIT-COMPANIES.COM

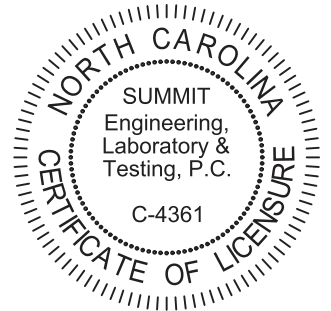

PROJECT
Standard Details
Stemwall Details
CLIENT
Smith Douglas Homes
110 Village Trail, Suite 215
Woodstock, GA 30188

CURRENT DRAWING
DATE: 2/18/20
SCALE: NTS
PROJECT #: 3832
DRAWN BY: LBV
CHECKED BY: WAJ
ORIGINAL DRAWING
NO. DATE PROJECT #
0 1/7/16 3832

REFER TO COVER SHEET FOR A COMPLETE LIST OF REVISIONS

SHEET
D2s

- NOTES:
- REFER TO GENERAL NOTES & SPECIFICATIONS ON SHEET CS2 FOR ADDITIONAL INFORMATION.
 - PROVIDE 6 MIL VAPOR BARRIER UNDER ALL SLABS-ON-GRADE.
 - SEE ARCH. DWGS. FOR ALL TOP OF THE SLAB ELEVATIONS, SLOPES AND DEPRESSIONS.

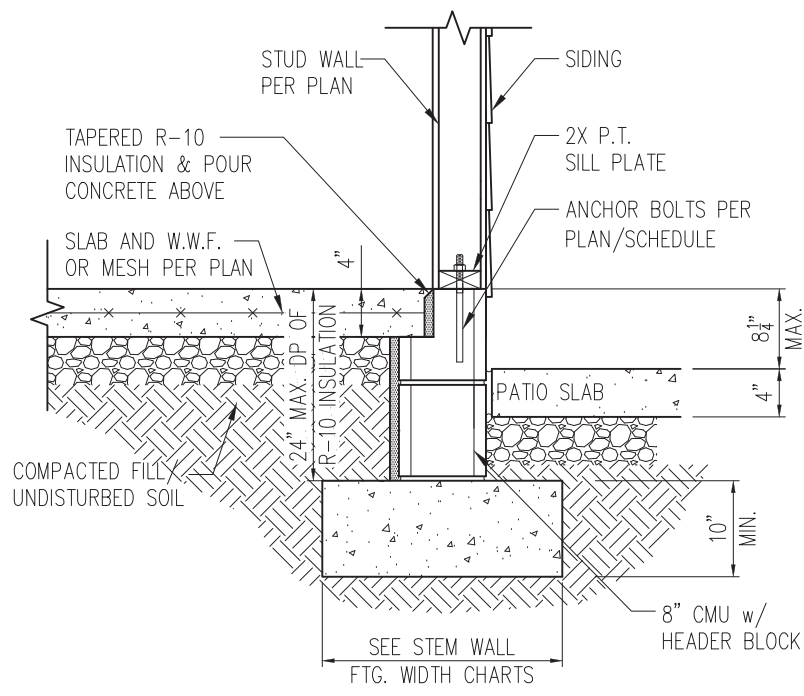

STANDARD - SIDING

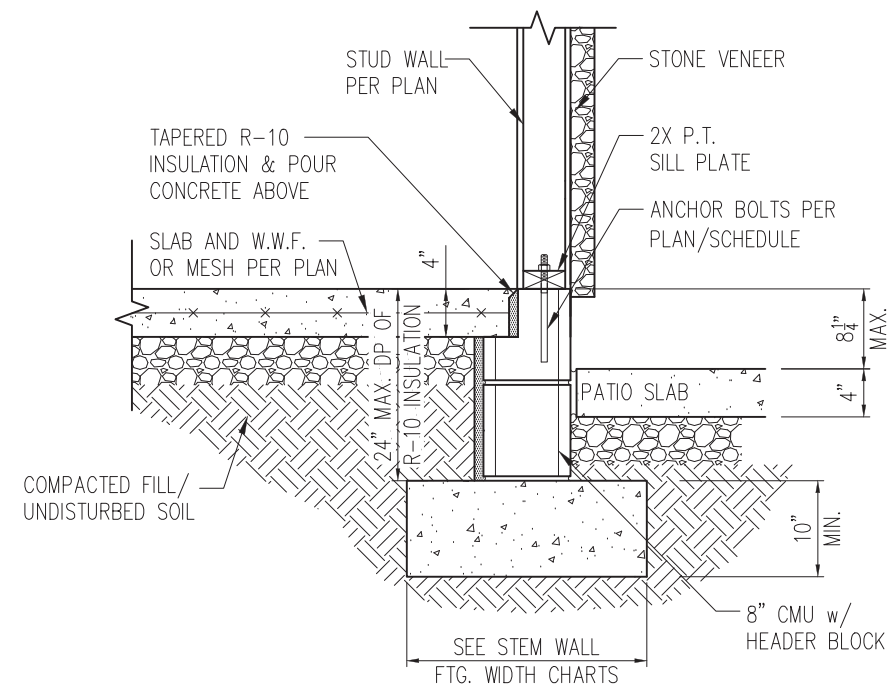

STANDARD - STONE

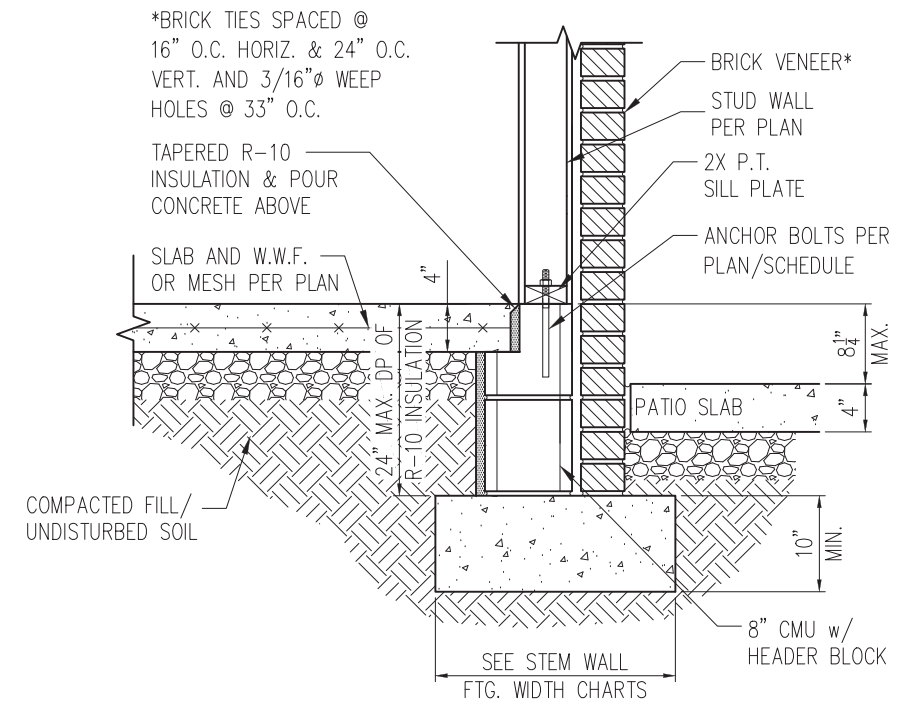

STANDARD - BRICK

1 PORCH SLAB DETAIL
D3s 3/4" = 1'-0"

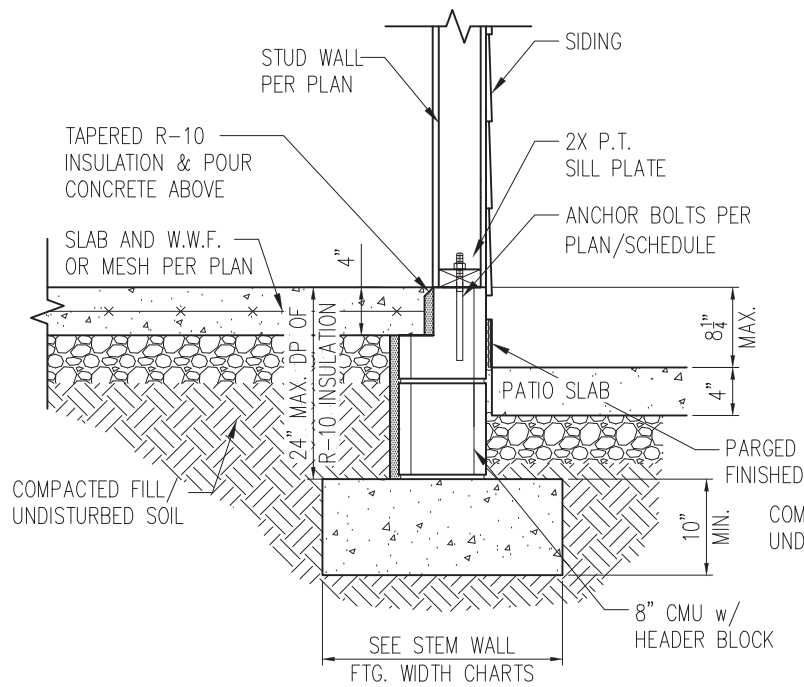

STANDARD - SIDING

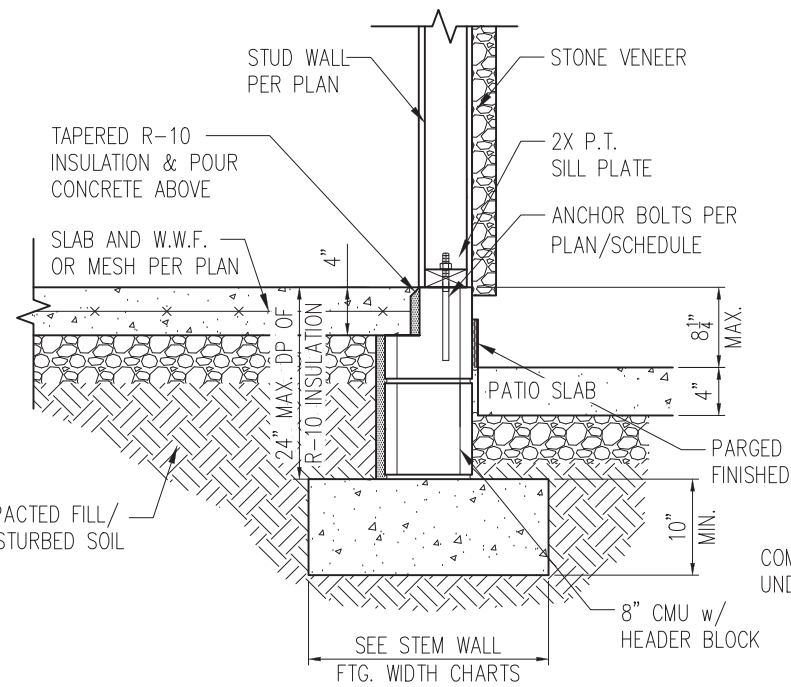

STANDARD - STONE

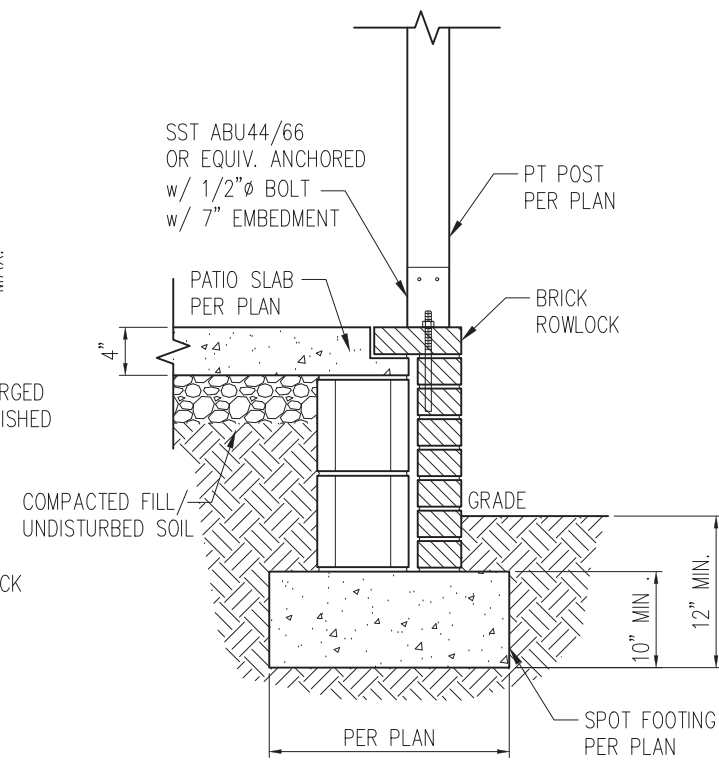

2 COVERED PORCH DETAIL
D3s 3/4" = 1'-0"

- NOTES:
1. REFER TO GENERAL NOTES & SPECIFICATIONS ON SHEET CS2 FOR ADDITIONAL INFORMATION.
 2. PROVIDE 6 MIL VAPOR BARRIER UNDER ALL SLABS-ON-GRADE.
 3. SEE ARCH. DWGS. FOR ALL TOP OF THE SLAB ELEVATIONS, SLOPES AND DEPRESSIONS.

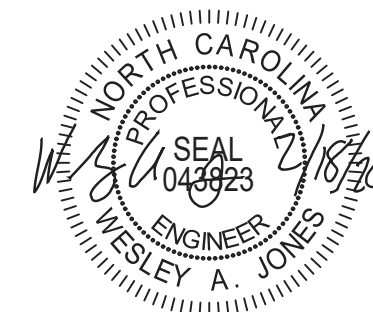

STRUCTURAL MEMBERS ONLY

SUMMIT
ENGINEERING LABORATORY TESTING
3070 HAMMOND BUSINESS PLACE,
SUITE 171, RALEIGH, NC 27603
OFFICE: 919.380.9991
FAX: 919.380.9993
WWW.SUMMIT-COMPANIES.COM

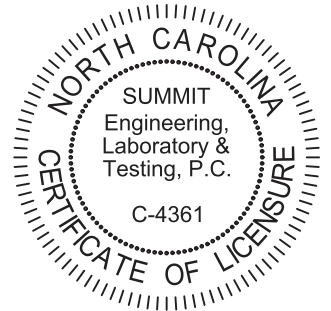

PROJECT
Standard Details
Stemwall Details
CLIENT
Smith Douglas Homes
110 Village Trail, Suite 215
Woodstock, GA 30188

CURRENT DRAWING
DATE: 2/18/20
SCALE: NTS
PROJECT #: 3832
DRAWN BY: LBV
CHECKED BY: WAJ

ORIGINAL DRAWING
NO. DATE PROJECT #
0 1/7/16 3832

REFER TO COVER SHEET FOR A COMPLETE LIST OF REVISIONS

SHEET
D3s

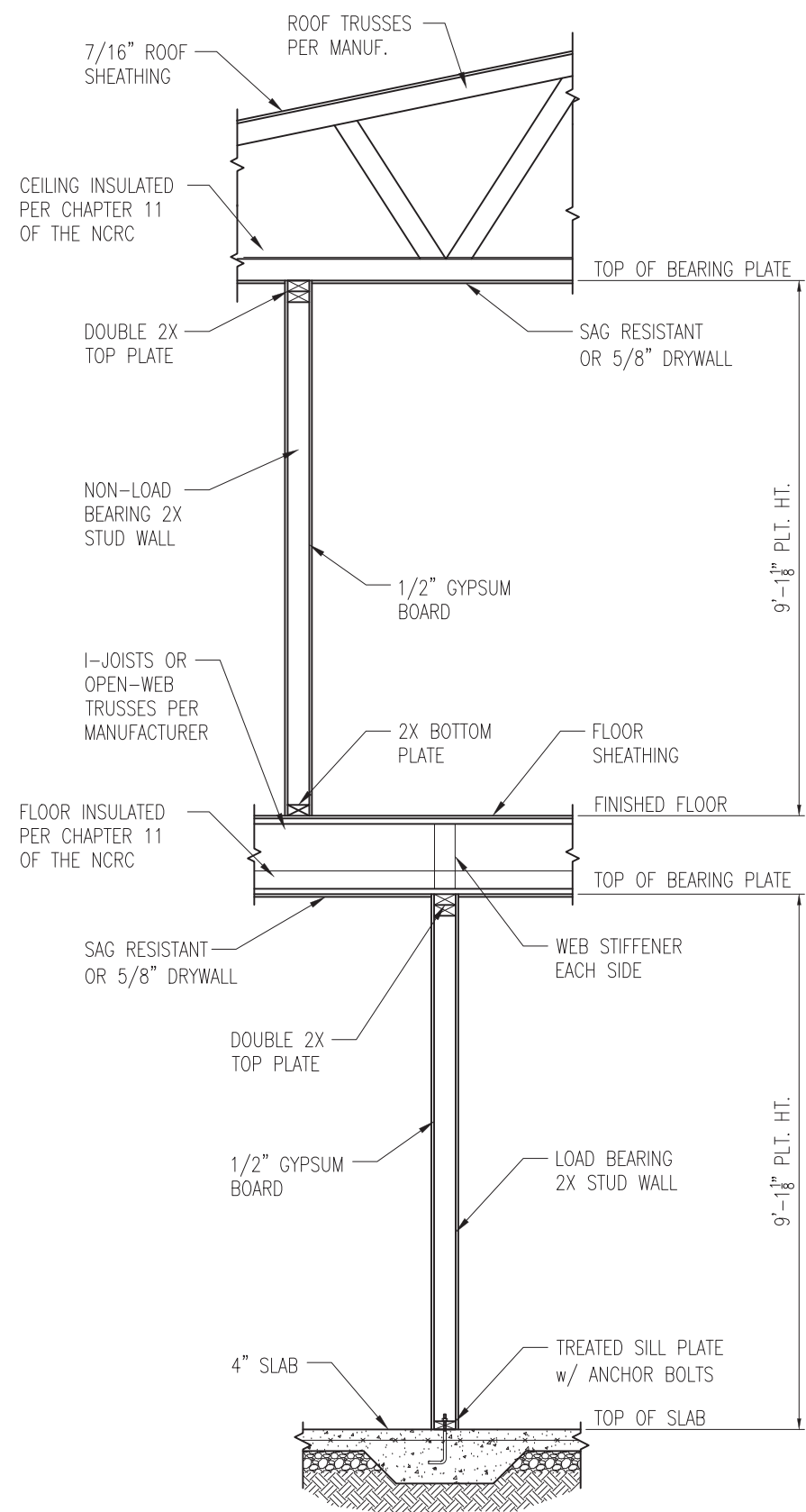

1 TYP. INTERIOR LOAD BEARING WALL SECTION
 D4s 3/4" = 1'-0"

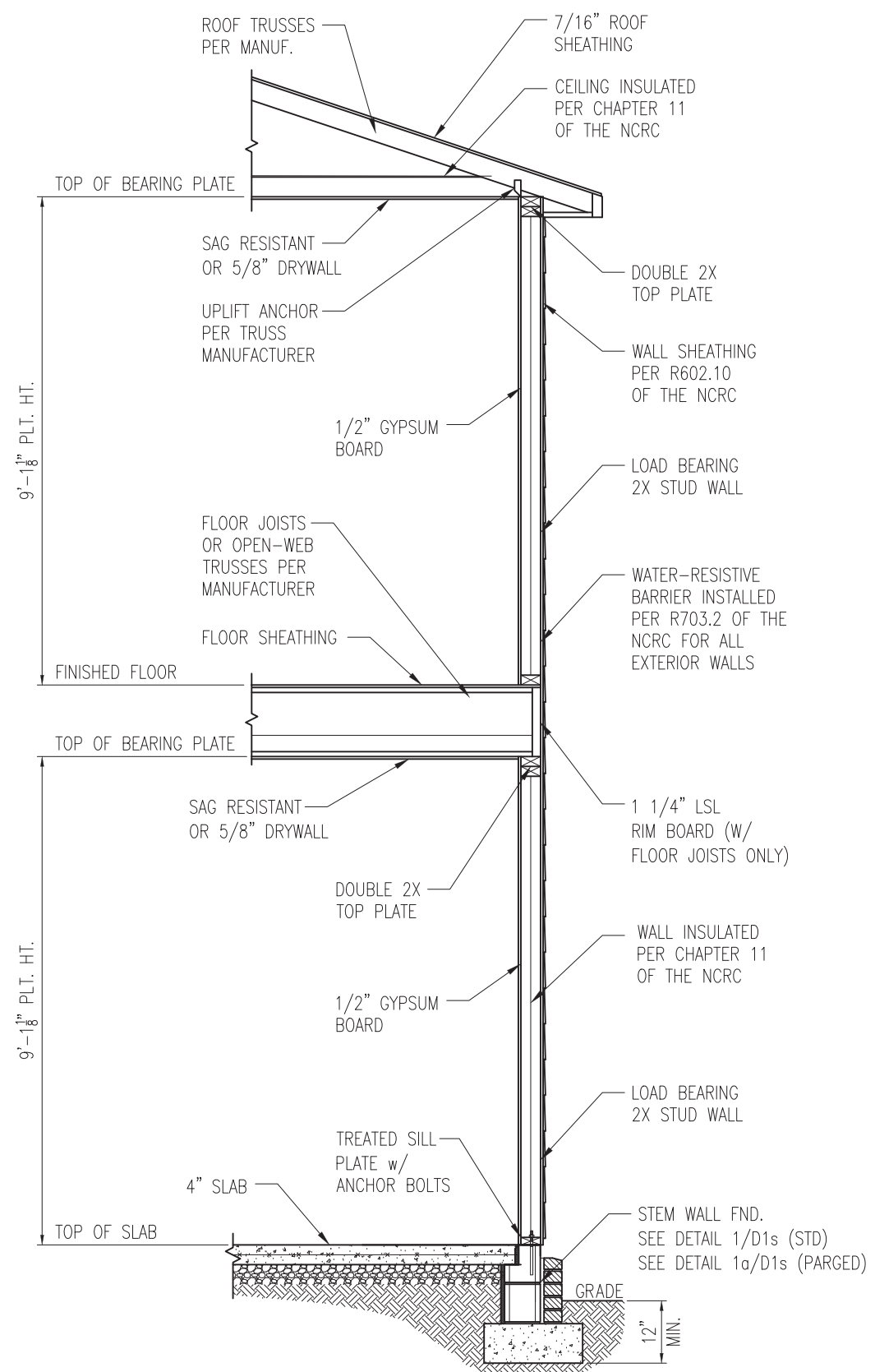

2 TYP. EXTERIOR LOAD BEARING WALL SECTION
 D4s 3/4" = 1'-0"
 -SIMILAR w/ BRICK AND STONE
 -BRICK TIES SPACED @ 16" O.C. HORIZ. & 24" O.C. VERT.
 -MIN. 3/16" Ø WEEP HOLES @ 33" O.C.

- NOTES:
1. REFER TO GENERAL NOTES & SPECIFICATIONS ON SHEET CS2 FOR ADDITIONAL INFORMATION.
 2. PROVIDE 6 MIL VAPOR BARRIER UNDER ALL SLABS-ON-GRADE.
 3. SEE ARCH. DWGS. FOR ALL TOP OF THE SLAB ELEVATIONS, SLOPES AND DEPRESSIONS.



STRUCTURAL MEMBERS ONLY

SUMMIT
 ENGINEERING LABORATORY TESTING
 3070 HAMMOND BUSINESS PLACE,
 SUITE 171, RALEIGH, NC 27603
 OFFICE: 919.380.9991
 FAX: 919.380.9993
 WWW.SUMMIT-COMPANIES.COM

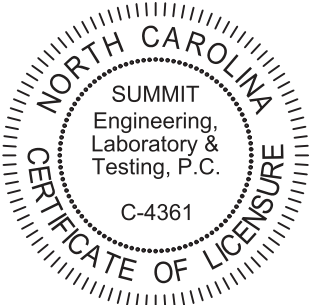

PROJECT
Standard Details
Stemwall Details
 CLIENT
Smith Douglas Homes
 110 Village Trail, Suite 215
 Woodstock, GA 30188

CURRENT DRAWING
 DATE: 2/18/20
 SCALE: NTS
 PROJECT #: 3832
 DRAWN BY: LBV
 CHECKED BY: WAJ

ORIGINAL DRAWING
 NO. DATE PROJECT #
 0 1/7/16 3832

REFER TO COVER SHEET FOR A COMPLETE LIST OF REVISIONS

SHEET
D4s

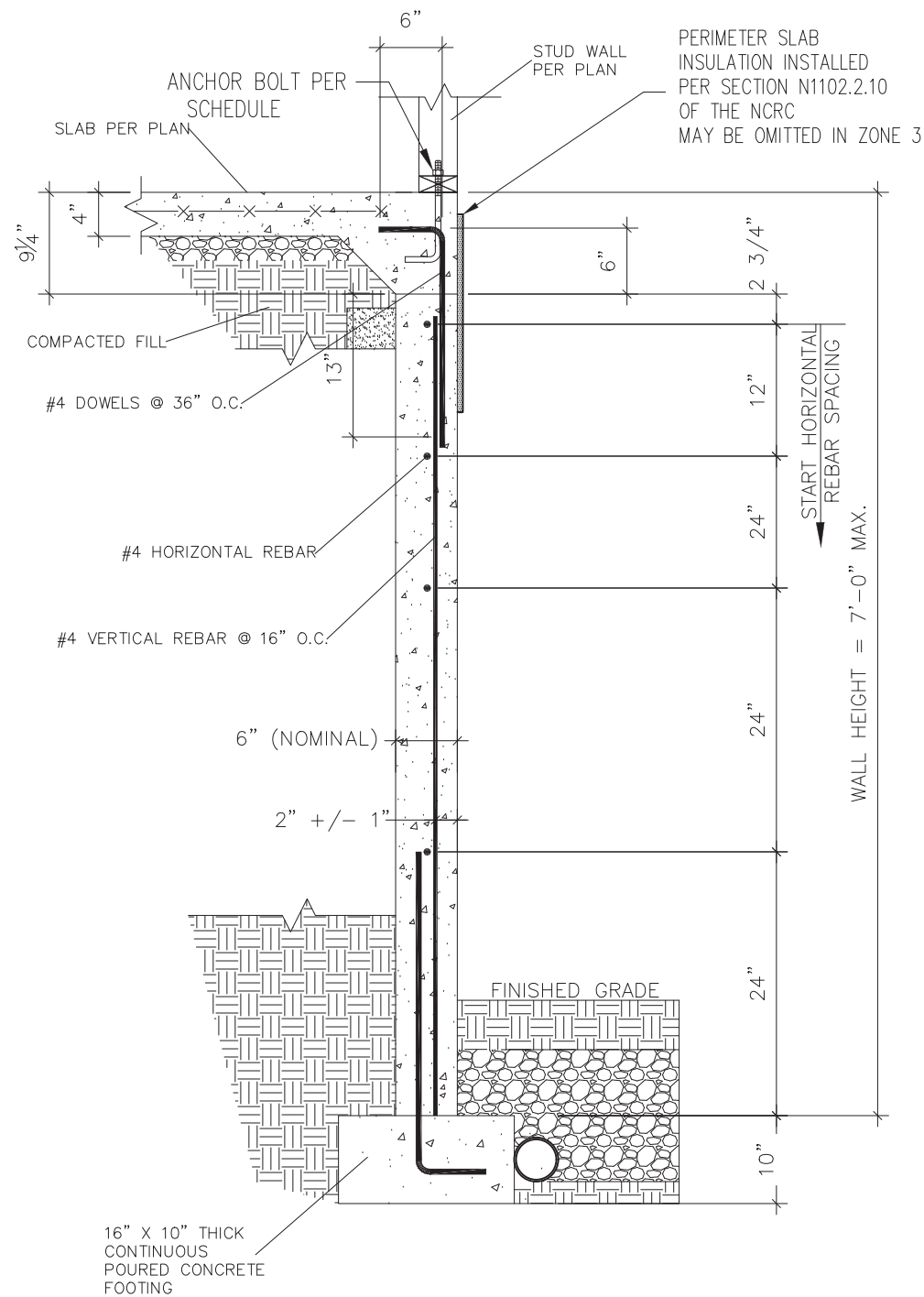

1 SUBWALL FOUNDATION
 D5s 3/4" = 1'-0"

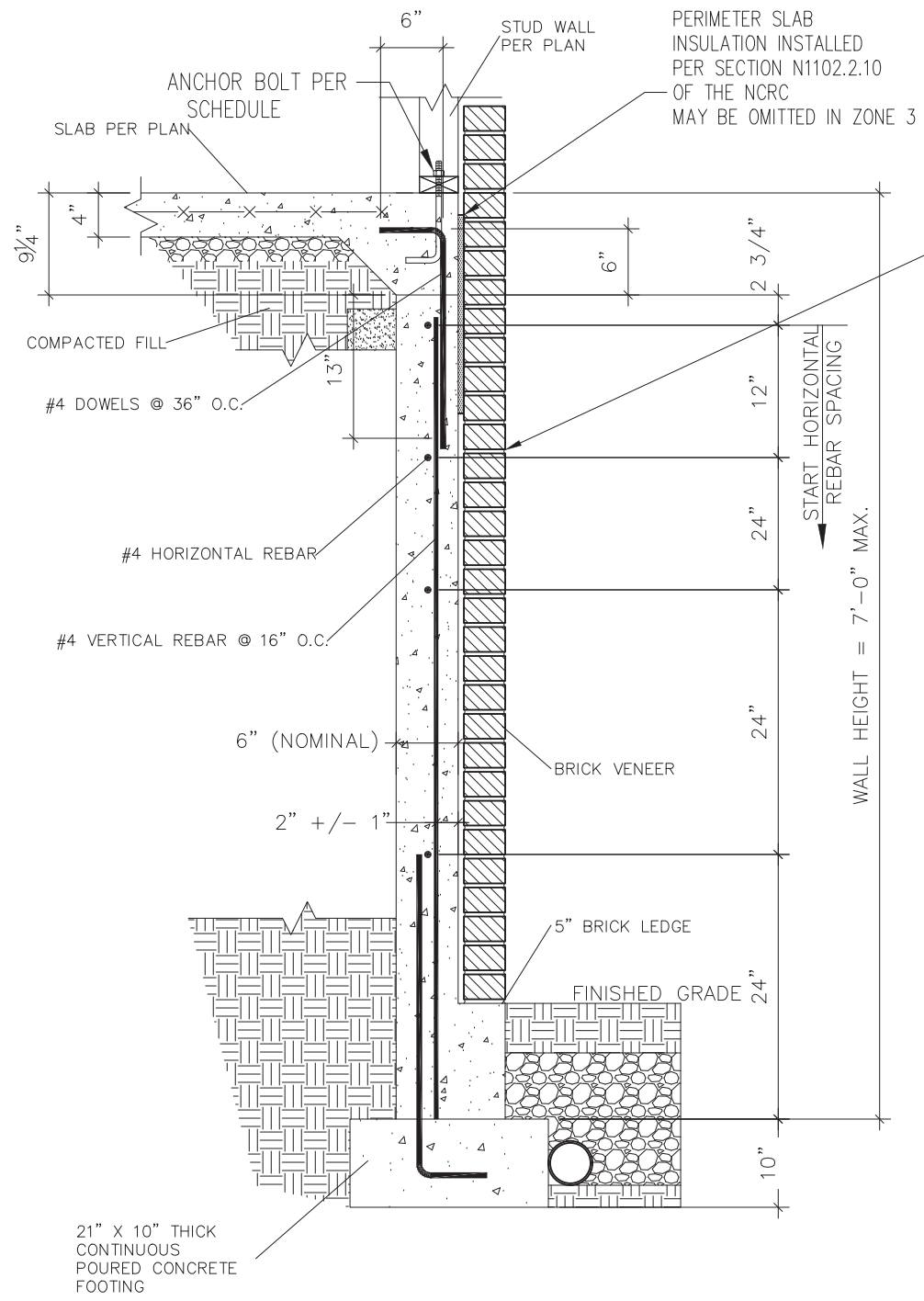

2 SUBWALL FOUNDATION W/ BRICK VENEER
 D5s 3/4" = 1'-0"

PROVIDE LADDER WIRE OR METAL TIES, INSTALLED PER R608.1.2 OF THE 2012 NCRC, AND FULLY GROUT BETWEEN BRICK AND CONCRETE.



STRUCTURAL MEMBERS ONLY

SUMMIT
 ENGINEERING LABORATORY TESTING
 3070 HAMMOND BUSINESS PLACE,
 SUITE 171, RALEIGH, NC 27603
 OFFICE: 919.380.9991
 FAX: 919.380.9993
 WWW.SUMMIT-COMPANIES.COM

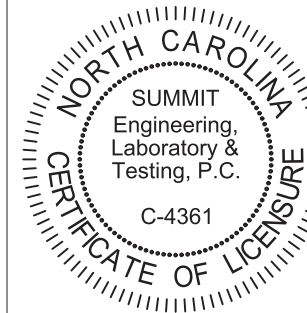

PROJECT
Standard Details
Stemwall Details
 CLIENT
 Smith Douglas Homes
 110 Village Trail, Suite 215
 Woodstock, GA 30188

CURRENT DRAWING
 DATE: 2/18/20
 SCALE: NTS
 PROJECT #: 3832
 DRAWN BY: LBV
 CHECKED BY: WAJ

ORIGINAL DRAWING
 NO. DATE PROJECT #
 0 1/7/16 3832

REFER TO COVER SHEET FOR A COMPLETE LIST OF REVISIONS

SHEET

D5s

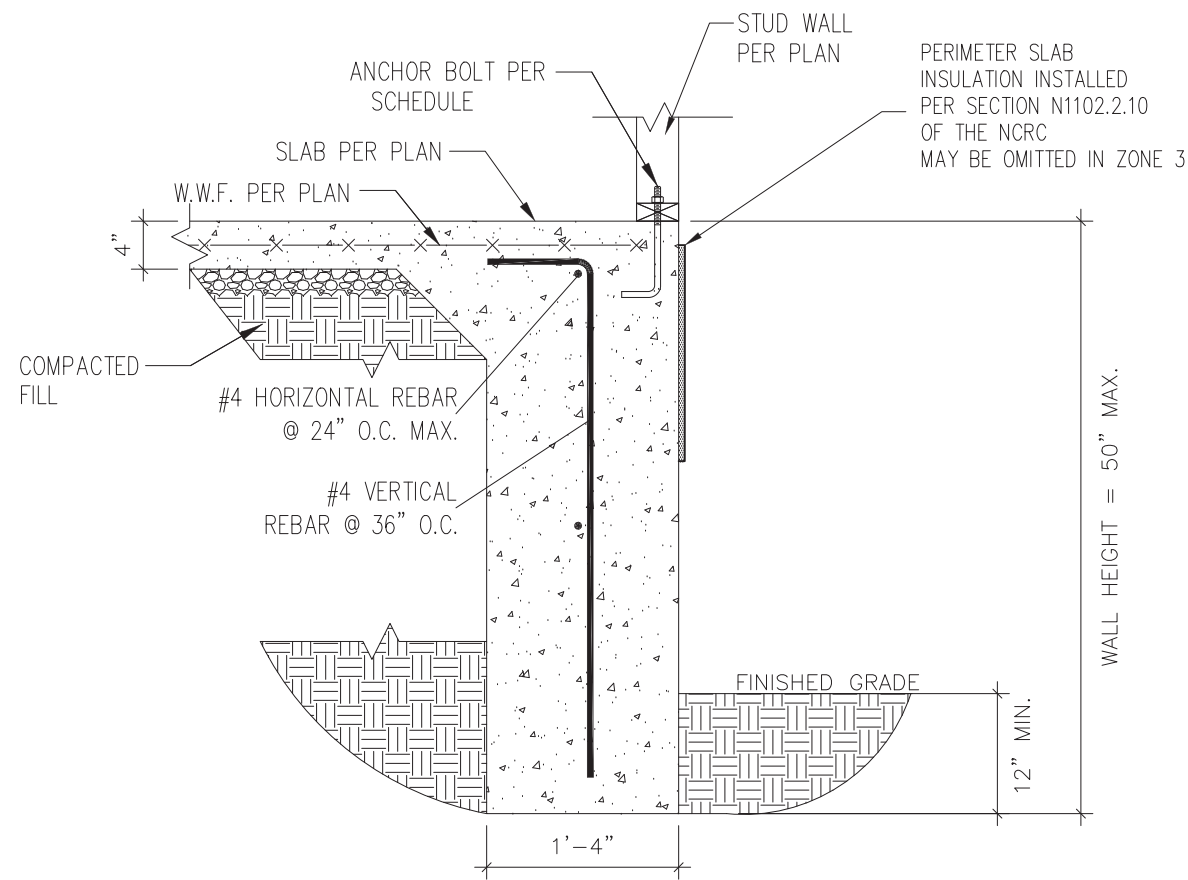

1 TURNDOWN FOUNDATION
 D6s 3/4" = 1'-0"

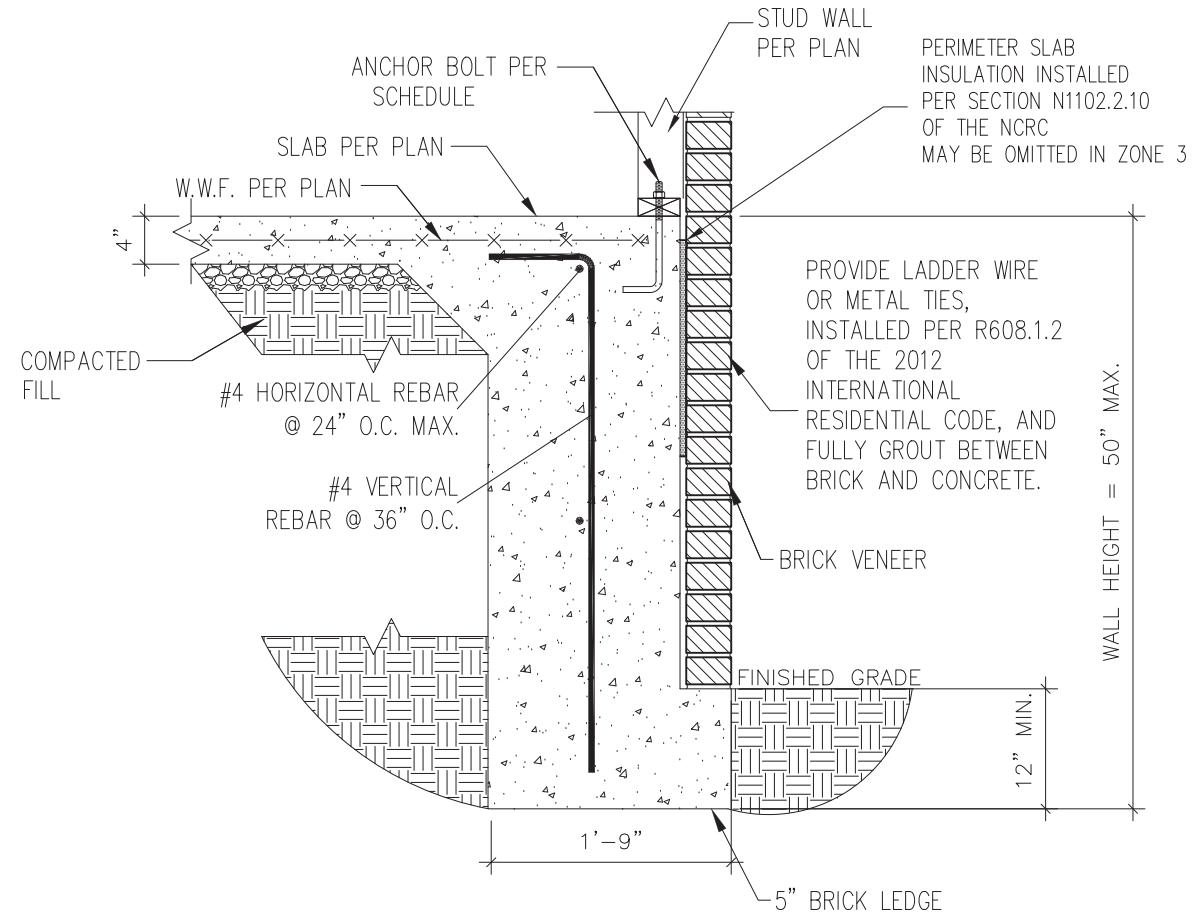

2 TURNDOWN FOUNDATION W/ BRICK VENEER
 D6s 3/4" = 1'-0"

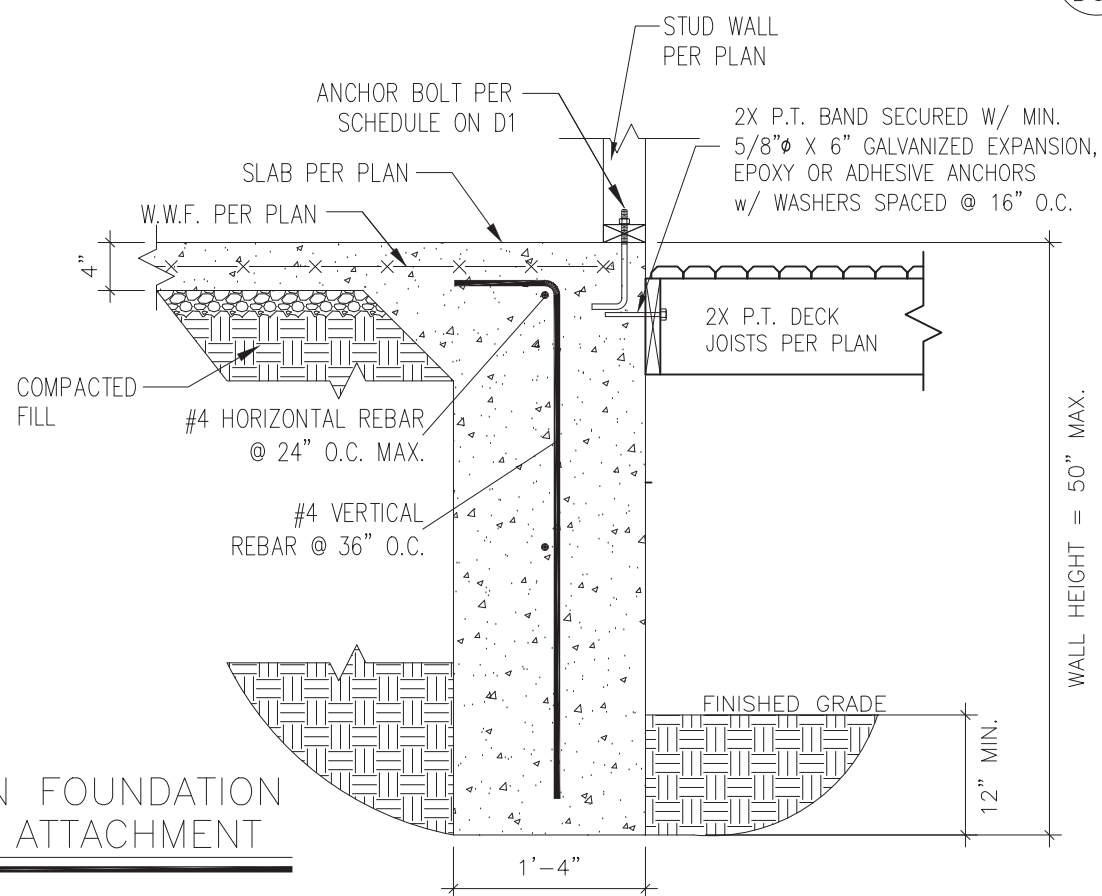

3 TURNDOWN FOUNDATION W/ DECK ATTACHMENT
 D6s 3/4" = 1'-0"



STRUCTURAL MEMBERS ONLY

SUMMIT
 ENGINEERING LABORATORY TESTING
 3070 HAMMOND BUSINESS PLACE,
 SUITE 171, RALEIGH, NC 27603
 OFFICE: 919.380.9991
 FAX: 919.380.9993
 WWW.SUMMIT-COMPANIES.COM

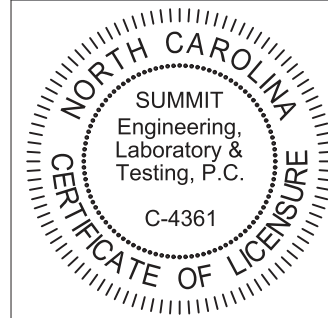

PROJECT
Standard Details
Stemwall Details
 CLIENT
Smith Douglas Homes
 110 Village Trail, Suite 215
 Woodstock, GA 30188

CURRENT DRAWING
 DATE: 2/18/20
 SCALE: NTS
 PROJECT #: 3832
 DRAWN BY: LBV
 CHECKED BY: WAJ

| NO. | DATE | PROJECT # |
|-----|--------|-----------|
| 0 | 1/7/16 | 3832 |

REFER TO COVER SHEET FOR A COMPLETE LIST OF REVISIONS

SHEET
D6s

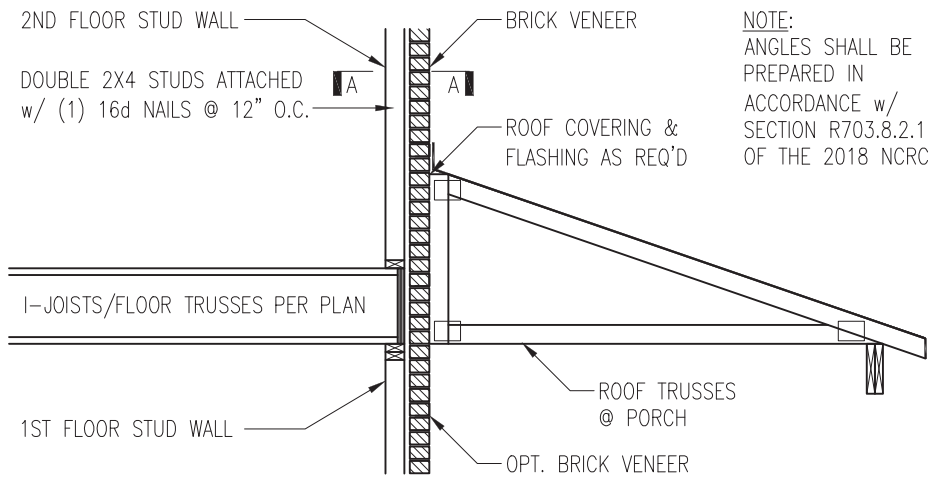

NOTE:
ANGLES SHALL BE PREPARED IN ACCORDANCE w/ SECTION R703.8.2.1 OF THE 2018 NCR

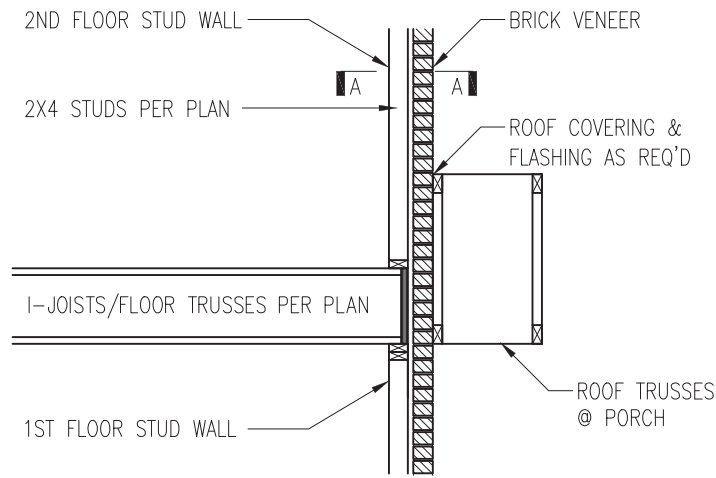

TRUSSES PERPENDICULAR TO STUD WALL

TRUSSES PARALLEL TO STUD WALL w/ CONTINUOUS BRICK VENEER

1 BRICK SUPPORT ABOVE STORAGE/PORCH ROOF DETAIL
D5f NTS

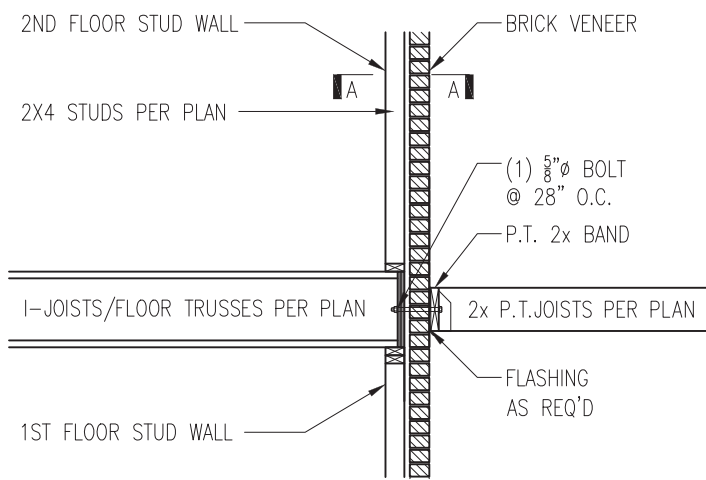

3 BALCONY JOIST ATTACHMENT
D5f NTS

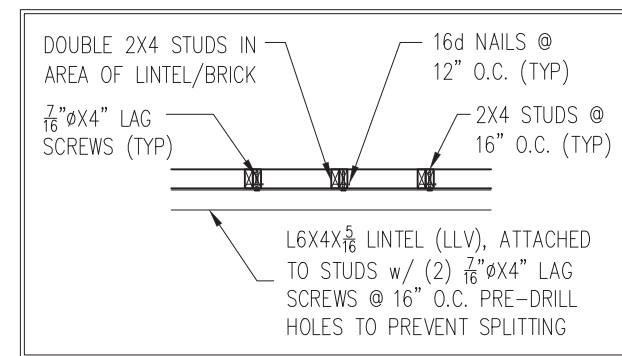

SECTION A-A
NTS

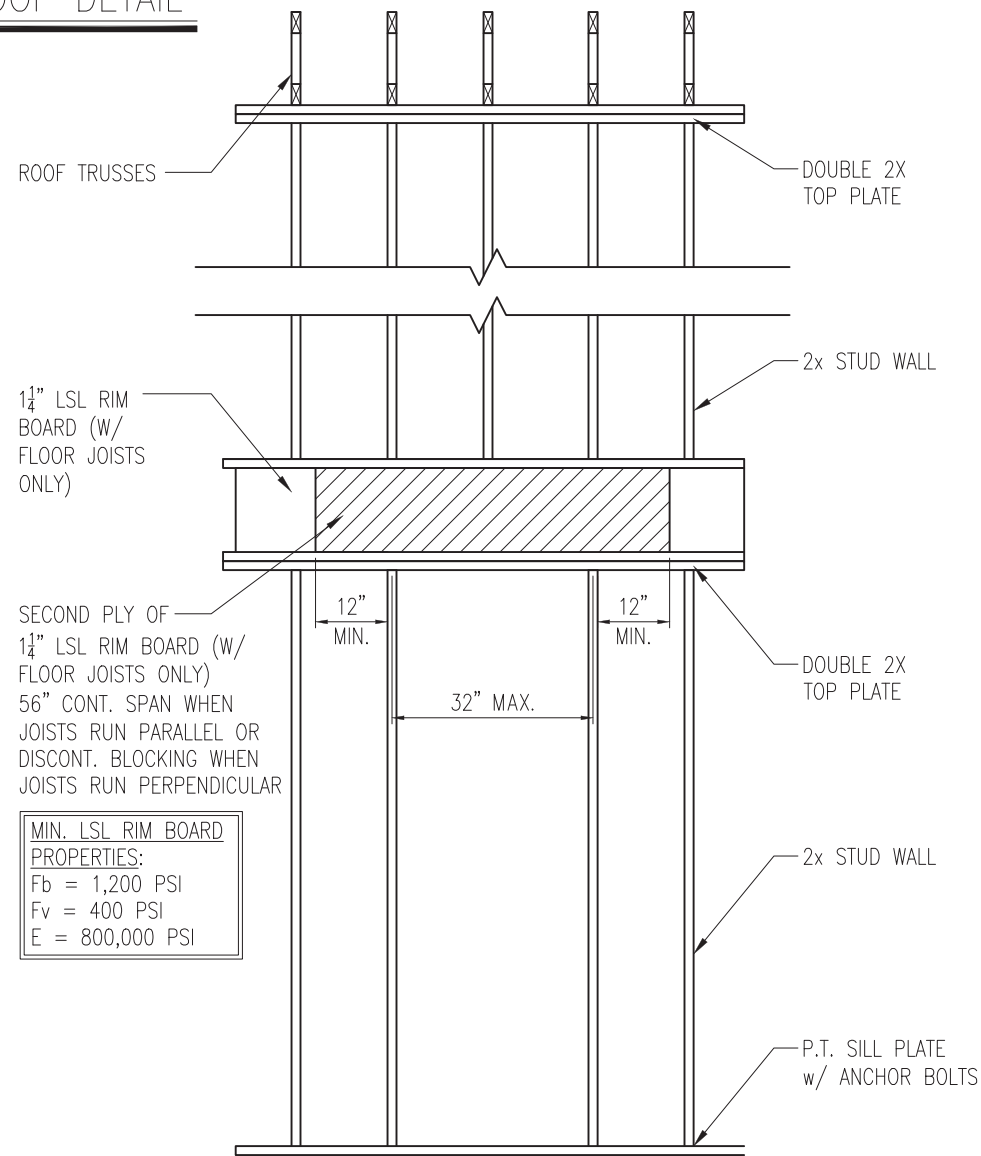

SECOND PLY OF 1 1/4\"/>

MIN. LSL RIM BOARD
PROPERTIES:
Fb = 1,200 PSI
Fv = 400 PSI
E = 800,000 PSI

4 TYP. RANGE VENT FRAMING
D5f VENTED TO EXTERIOR WALL

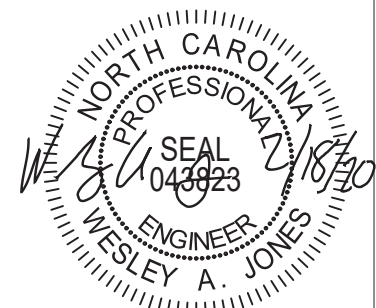

STRUCTURAL MEMBERS ONLY

SUMMIT
ENGINEERING LABORATORY TESTING
3070 HAMMOND BUSINESS PLACE,
SUITE 171, RALEIGH, NC 27603
OFFICE: 919.380.9991
FAX: 919.380.9993
WWW.SUMMIT-COMPANIES.COM

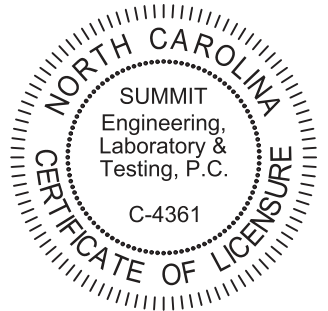

PROJECT
Standard Details
Framing Details
CLIENT
Smith Douglas Homes
110 Village Trail, Suite 215
Woodstock, GA 30188

CURRENT DRAWING
DATE: 2/18/20
SCALE: NTS
PROJECT #: 3832
DRAWN BY: LBV
CHECKED BY: WAJ

ORIGINAL DRAWING
NO. DATE PROJECT #
0 1/7/16 3832

REFER TO COVER SHEET FOR A COMPLETE LIST OF REVISIONS

SHEET
D5f

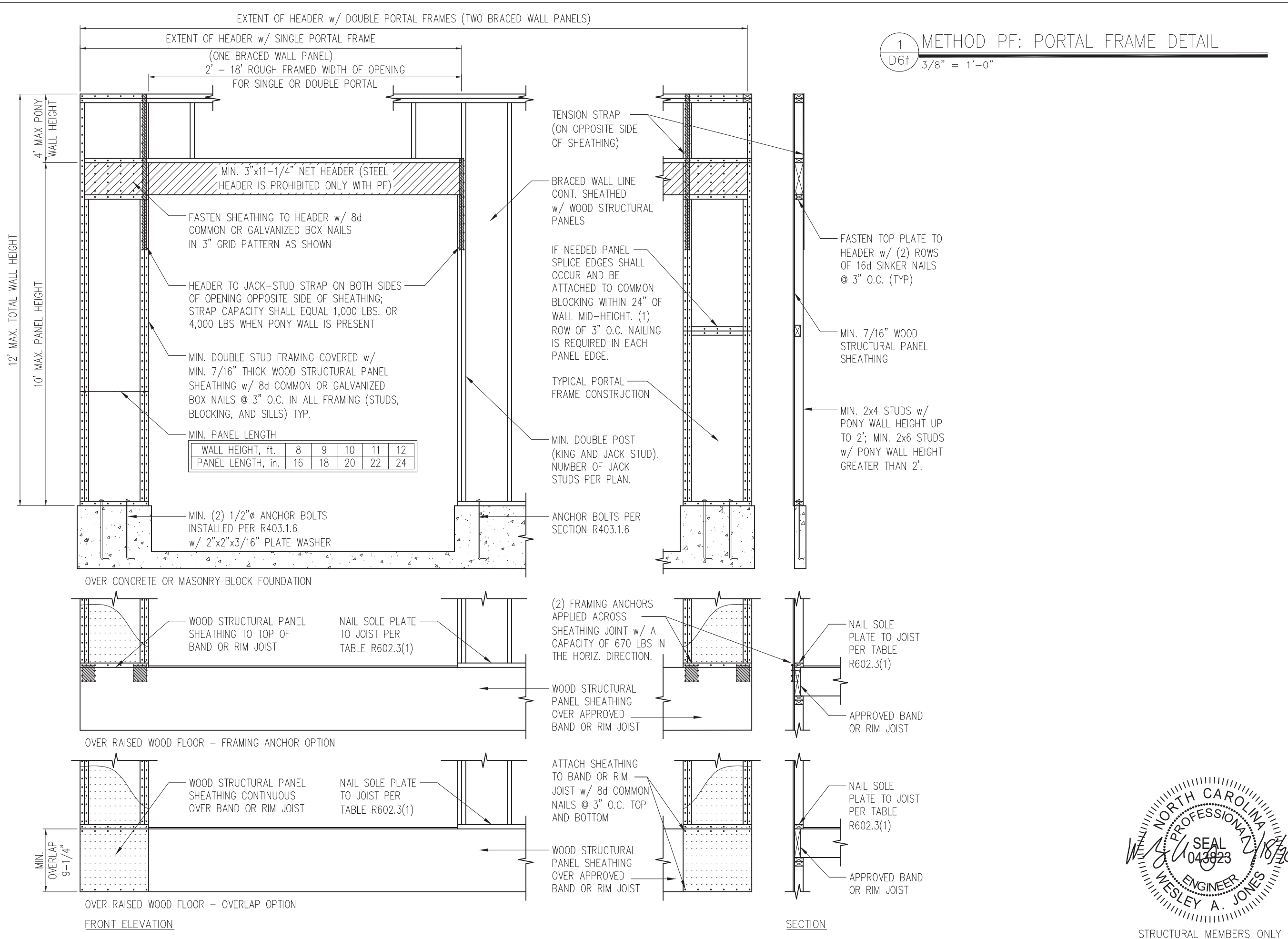

1 METHOD PF: PORTAL FRAME DETAIL
D6f 3/8" = 1'-0"

SUMMIT
ENGINEERING LABORATORY TESTING
3070 HAMMOND BUSINESS PLACE,
SUITE 171, RALEIGH, NC 27603
OFFICE: 919.380.9991
FAX: 919.380.9993
WWW.SUMMIT-COMPANIES.COM

NORTH CAROLINA
SUMMIT
Engineering,
Laboratory &
Testing, P.C.
C-4361
CERTIFICATE OF LICENSURE

PROJECT
Standard Details
Framing Details - Bracing

CLIENT
Smith Douglas Homes
110 Village Trail, Suite 215
Woodstock, GA 30188

CURRENT DRAWING
DATE: 2/18/20
SCALE: NTS
PROJECT #: 3832
DRAWN BY: LBV
CHECKED BY: WAJ

ORIGINAL DRAWING
NO. DATE PROJECT #
0 1/7/16 3832

REFER TO COVER SHEET FOR A COMPLETE LIST OF REVISIONS

NORTH CAROLINA
PROFESSIONAL
SEAL
043823
ENGINEER
WESLEY A. JONES

SHEET
D6f
STRUCTURAL MEMBERS ONLY

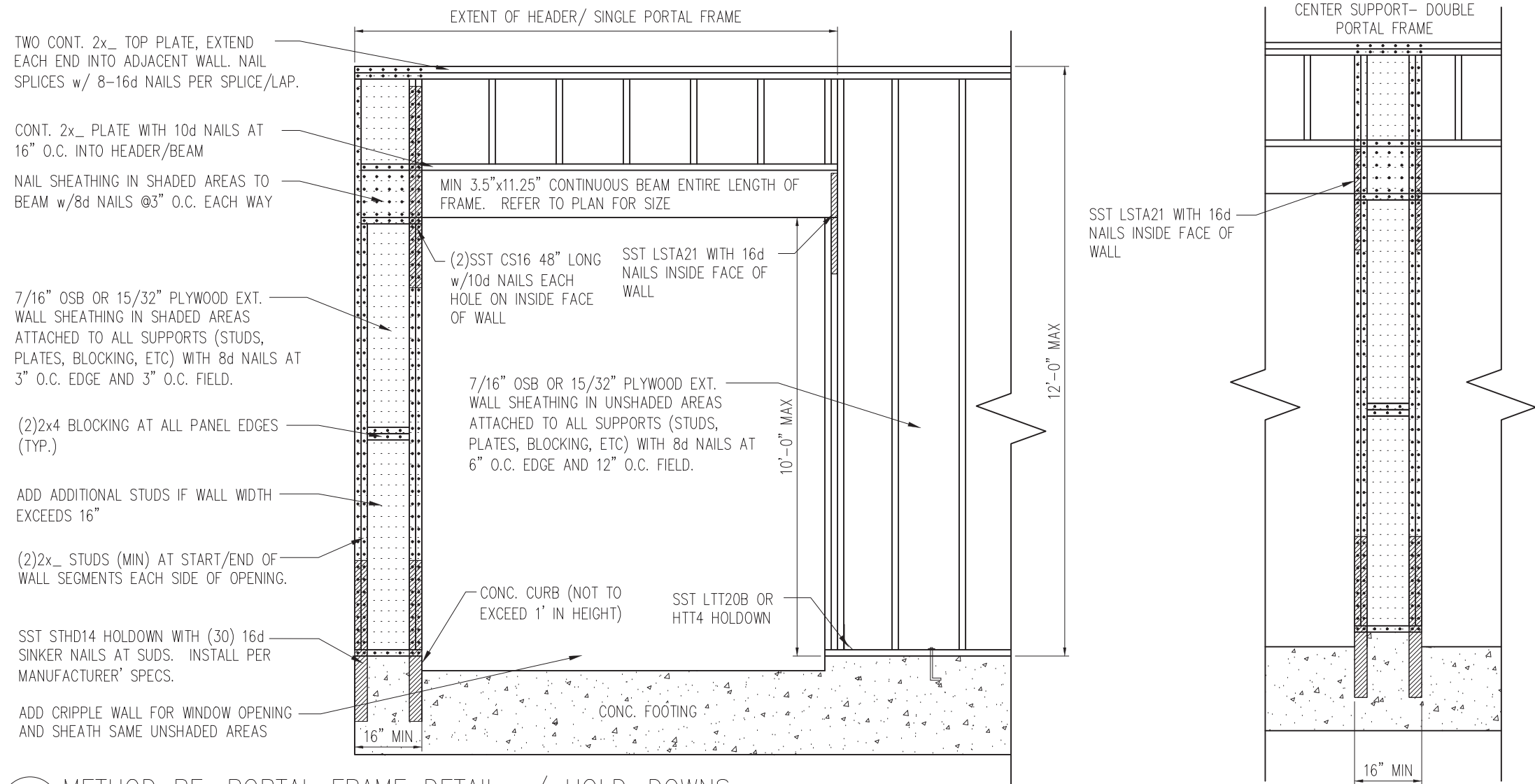

1 METHOD PF: PORTAL FRAME DETAIL w/ HOLD-DOWNS
 D7f 3/4" = 1'-0"

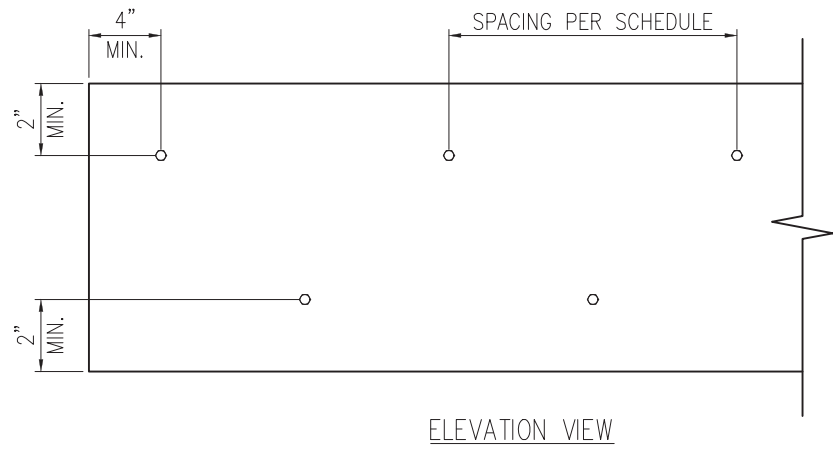

2 MULTI-PLY BEAM CONNECTION DETAIL
 D7f N.T.S

MINIMUM FASTENING REQUIREMENTS FOR TOP- AND SIDE-LOADED MEMBERS

| FASTENER TYPE | LVL DEPTH | 3/4" WIDE | | 5/4" WIDE | | 7" WIDE | |
|--|----------------|-------------------|------------------------|-------------------|------------------------|------------------------|--------------|
| | | 2-Ply 1 3/4" | 3-Ply 1 3/4" | 1 3/4" + 3 1/2" | 4-Ply 1 3/4" | 2-Ply 1 3/4" + 3 1/2" | 2-Ply 3 1/2" |
| 10d (0.128" x 3") Nails | 7/4" ≤ d < 14" | 3 rows @ 12" o.c. | 3 rows @ 12" o.c. (ES) | 3 rows @ 12" o.c. | - | 3 rows @ 12" o.c. (ES) | - |
| | d ≥ 14" | 4 rows @ 12" o.c. | 4 rows @ 12" o.c. (ES) | 4 rows @ 12" o.c. | - | 4 rows @ 12" o.c. (ES) | - |
| 16d (0.162" x 3 1/2") Nails | 7/4" ≤ d < 14" | 2 rows @ 12" o.c. | 2 rows @ 12" o.c. (ES) | 2 rows @ 12" o.c. | - | 2 rows @ 12" o.c. (ES) | - |
| | d ≥ 14" | 3 rows @ 12" o.c. | 3 rows @ 12" o.c. (ES) | 3 rows @ 12" o.c. | - | 3 rows @ 12" o.c. (ES) | - |
| 1/2" Through Bolts | d ≥ 7/4" | 2 rows @ 24" o.c. | 2 rows @ 24" o.c. | | 2 rows @ 24" o.c. | | |
| SDS 1/4" x 3 1/2", WS35, 3 3/8" TrussLok | | 2 rows @ 24" o.c. | 2 rows @ 24" o.c. (ES) | 2 rows @ 24" o.c. | - | 2 rows @ 24" o.c. (ES) | - |
| SDS 1/4" x 6", WS6 | | - | - | - | 2 rows @ 24" o.c. (ES) | | |
| 5" TrussLok | | - | 2 rows @ 24" o.c. | | - | | |
| 6 3/4" TrussLok | | - | - | - | 2 rows @ 24" o.c. | | |

NOTES:

- All fasteners must meet the minimum requirements in the table above. Side-loaded multiple-ply members must meet the minimum fastening and side-loading capacity requirements given on page 48.
- Minimum fastening requirements for depths less than 7/4" require special consideration. Please contact your technical representative.
- Three general rules for staggering or offsetting for a certain fastener schedule:
 - If staggering or offsetting is not referenced, then none is required;
 - If staggering is referenced, then fasteners installed in adjacent rows on the front side are to be staggered up to one-half the o.c. spacing, but maintaining the fastener clearances above; and
 - If "ES" is referenced, then the fastener schedule must be repeated on each side, with the fasteners on the back side offset up to one-half the o.c. spacing of the front side (whether or not it is staggered).

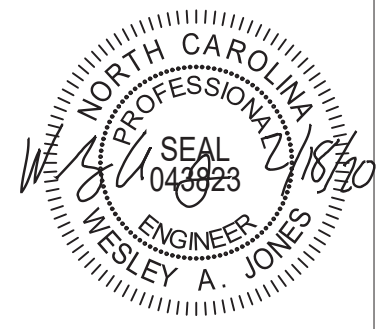

STRUCTURAL MEMBERS ONLY

SUMMIT
 ENGINEERING LABORATORY TESTING
 3070 HAMMOND BUSINESS PLACE,
 SUITE 171, RALEIGH, NC 27603
 OFFICE: 919.380.9991
 FAX: 919.380.9993
 WWW.SUMMIT-COMPANIES.COM

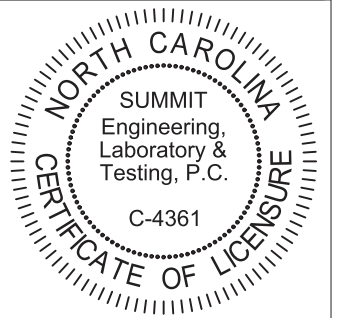

PROJECT
 Standard Details
 Framing Details - Bracing
 CLIENT
 Smith Douglas Homes
 110 Village Trail, Suite 215
 Woodstock, GA 30188

CURRENT DRAWING
 DATE: 2/18/20
 SCALE: NTS
 PROJECT #: 3832
 DRAWN BY: LBV
 CHECKED BY: WAJ
 ORIGINAL DRAWING
 NO. DATE PROJECT #
 0 1/7/16 3832

REFER TO COVER SHEET FOR A COMPLETE LIST OF REVISIONS

SHEET
D7f

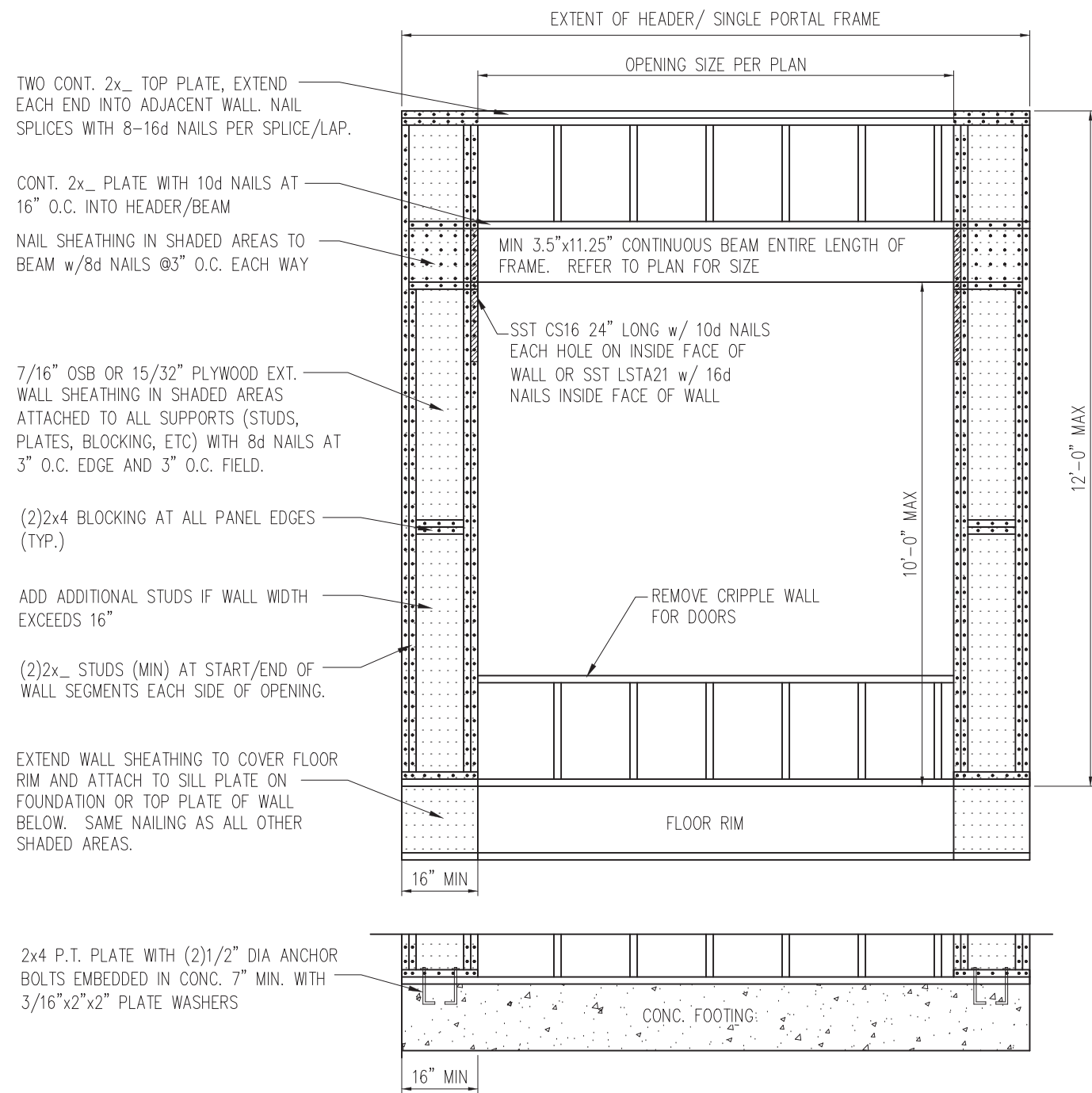

1 METHOD PF: PORTAL FRAME DETAIL
 D8f 3/4" = 1'-0" OPENINGS UNDER 8'-0"

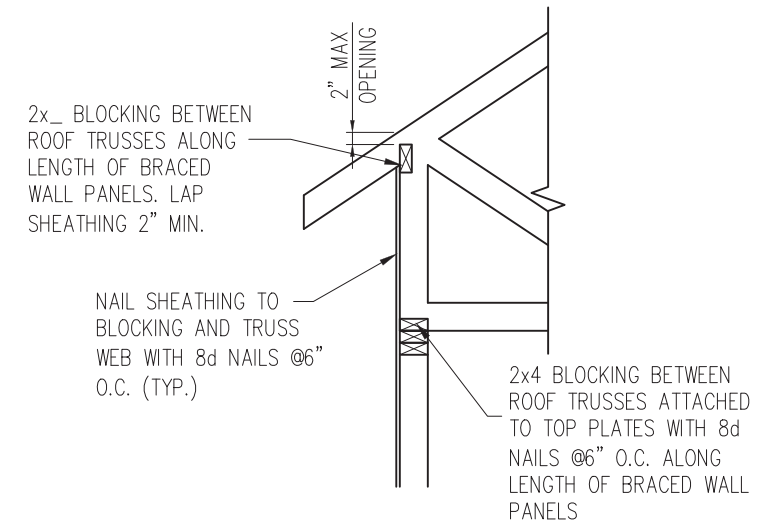

HEEL HEIGHT GREATER THAN 15.25"

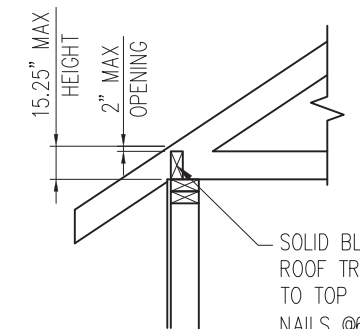

HEEL HEIGHT LESS THAN 15.25" *

*BLOCKING IS NOT REQUIRED WITH HEEL HEIGHTS LESS THAN 9.25"

2 TYP. WALL PANEL TO ROOF TRUSS CONNECTION
 D8f 1" = 1'-0"



STRUCTURAL MEMBERS ONLY

SUMMIT
 ENGINEERING LABORATORY TESTING
 3070 HAMMOND BUSINESS PLACE,
 SUITE 171, RALEIGH, NC 27603
 OFFICE: 919.380.9991
 FAX: 919.380.9993
 WWW.SUMMIT-COMPANIES.COM

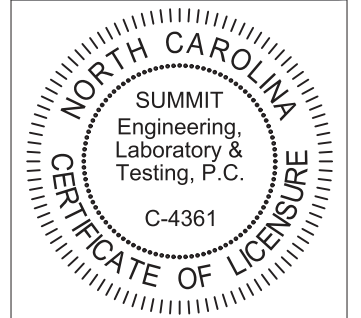

PROJECT
Standard Details
Framing Details - Bracing

CLIENT
Smith Douglas Homes
 110 Village Trail, Suite 215
 Woodstock, GA 30188

CURRENT DRAWING
 DATE: 2/18/20
 SCALE: NTS
 PROJECT #: 3832
 DRAWN BY: LBV
 CHECKED BY: WAJ

ORIGINAL DRAWING
 NO. DATE PROJECT #
 0 1/7/16 3832

REFER TO COVER SHEET FOR A COMPLETE LIST OF REVISIONS

SHEET
D8f

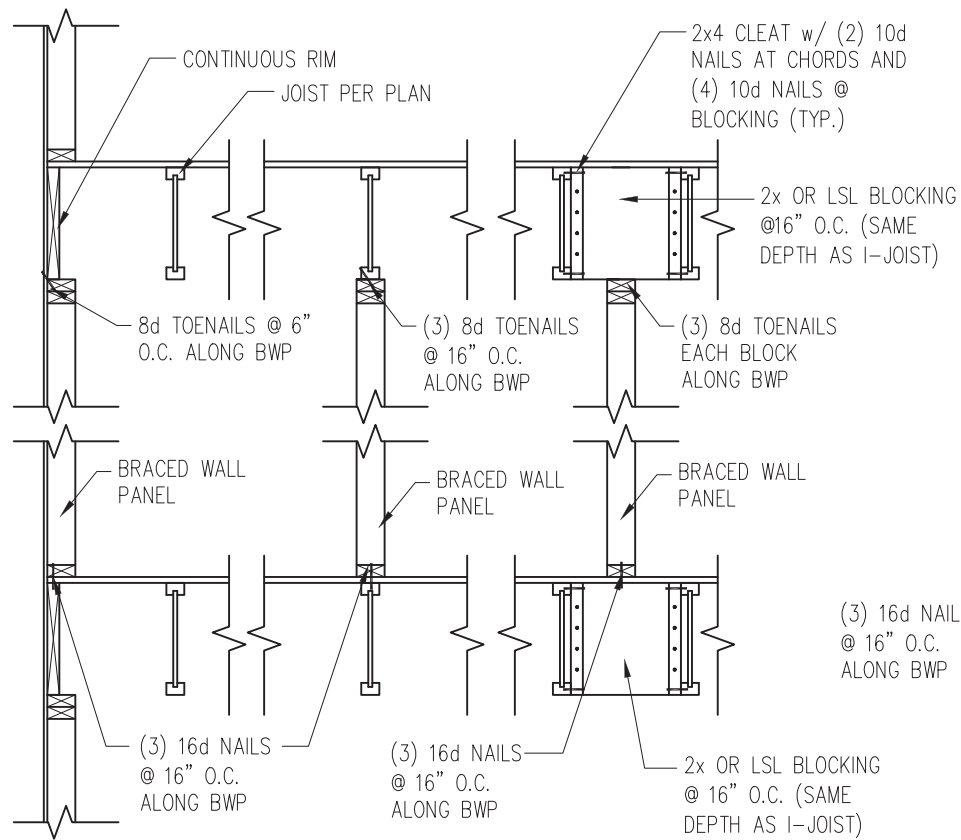

JOISTS PARALLEL TO BRACED WALLS

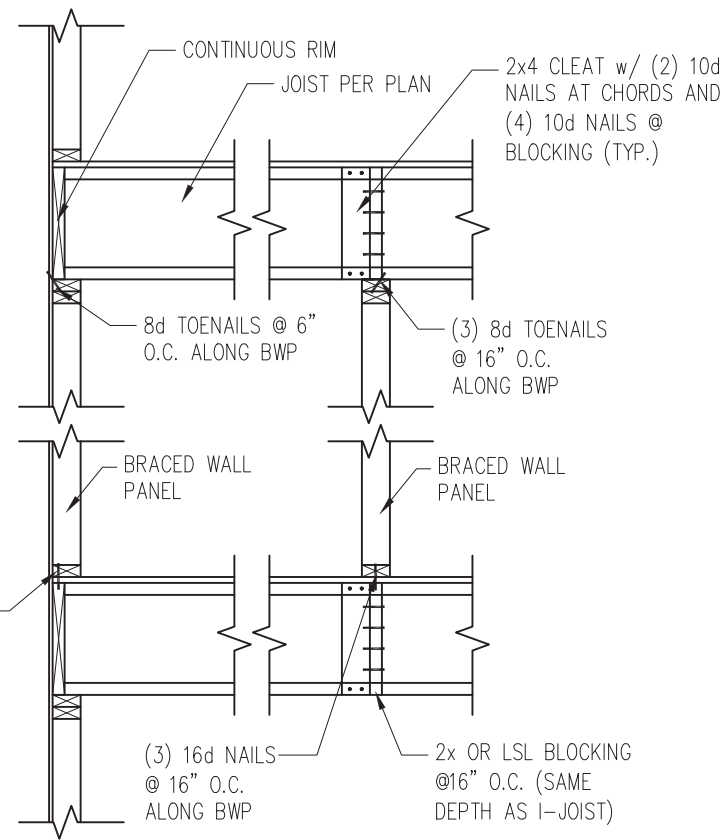

JOISTS PERPENDICULAR TO BRACED WALLS

1 TYP. WALL PANEL TO FLOOR/CEILING CONNECTION
D9f 1" = 1'-0"

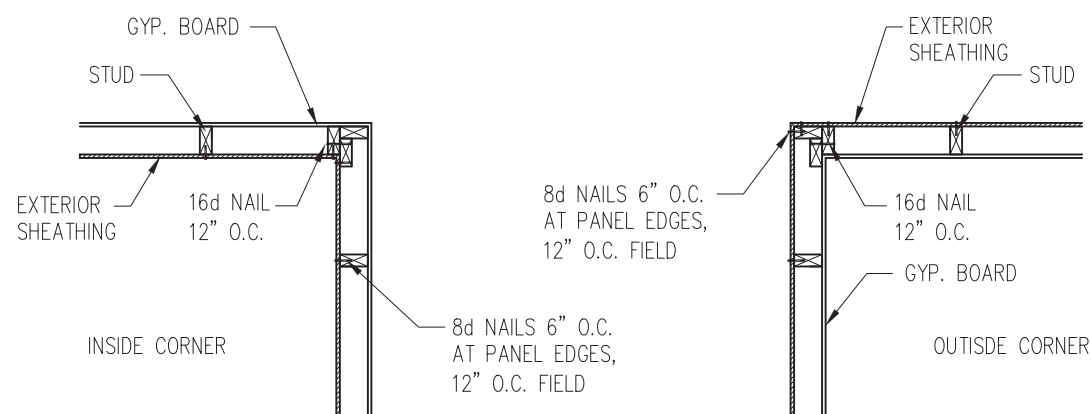

2 TYP. EXTERIOR CORNER FRAMING
D9f 1" = 1'-0"

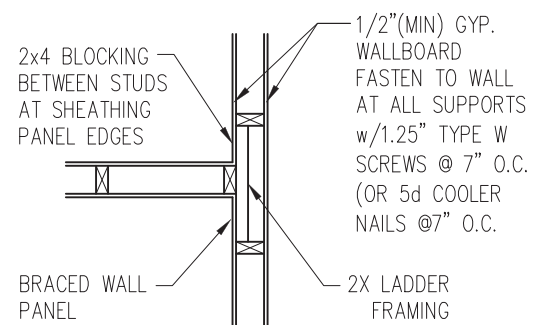

3 INTERIOR 3-STUD WALL INTERSECTION
D9f 1" = 1'-0"

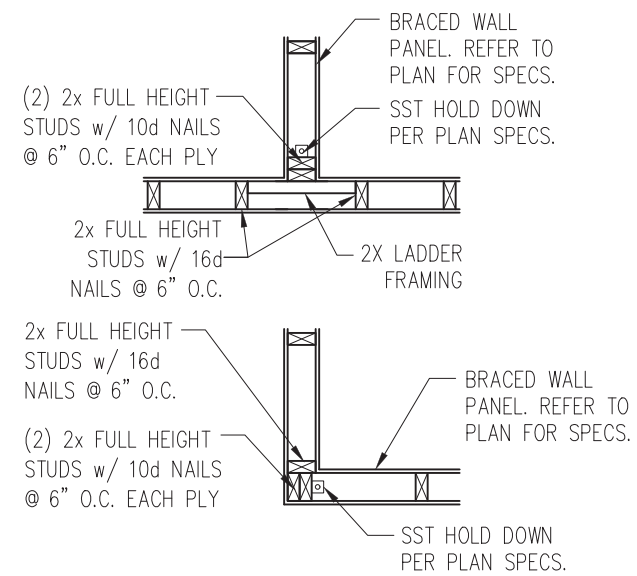

4 TYP. HOLD DOWN DETAIL
D9f 1" = 1'-0"



STRUCTURAL MEMBERS ONLY

SUMMIT
ENGINEERING LABORATORY TESTING
3070 HAMMOND BUSINESS PLACE,
SUITE 171, RALEIGH, NC 27603
OFFICE: 919.380.9991
FAX: 919.380.9993
WWW.SUMMIT-COMPANIES.COM

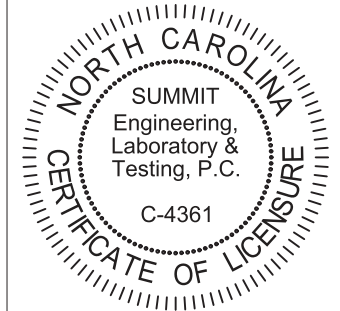

PROJECT
Standard Details
Framing Details - Bracing
CLIENT
Smith Douglas Homes
110 Village Trail, Suite 215
Woodstock, GA 30188

CURRENT DRAWING
DATE: 2/18/20
SCALE: NTS
PROJECT #: 3832
DRAWN BY: LBV
CHECKED BY: WAJ

ORIGINAL DRAWING
NO. DATE PROJECT #
0 1/7/16 3832

REFER TO COVER SHEET FOR A COMPLETE LIST OF REVISIONS

SHEET

D9f

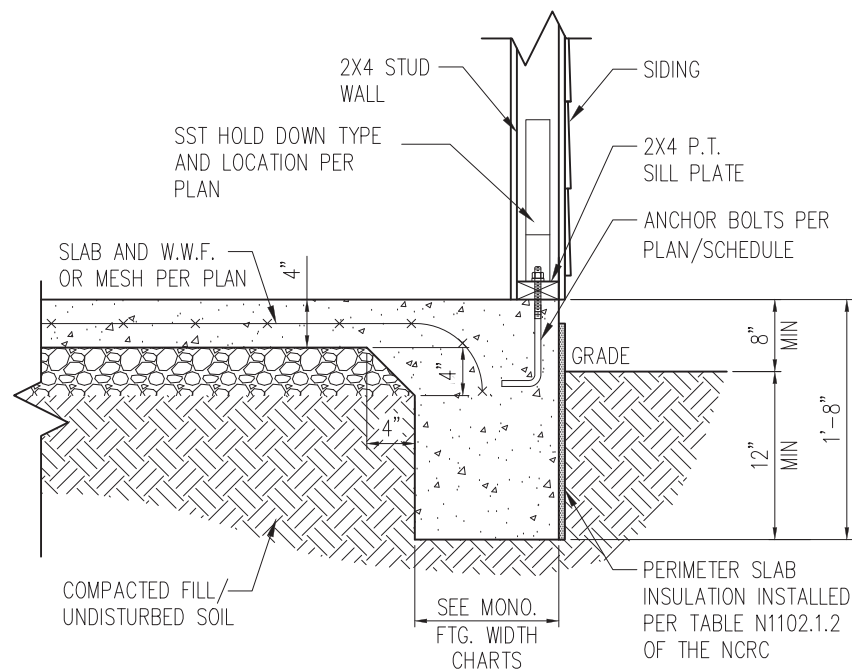

1 SLAB DETAIL w/ HOLD-DOWN
 D10f 3/4" = 1'-0"

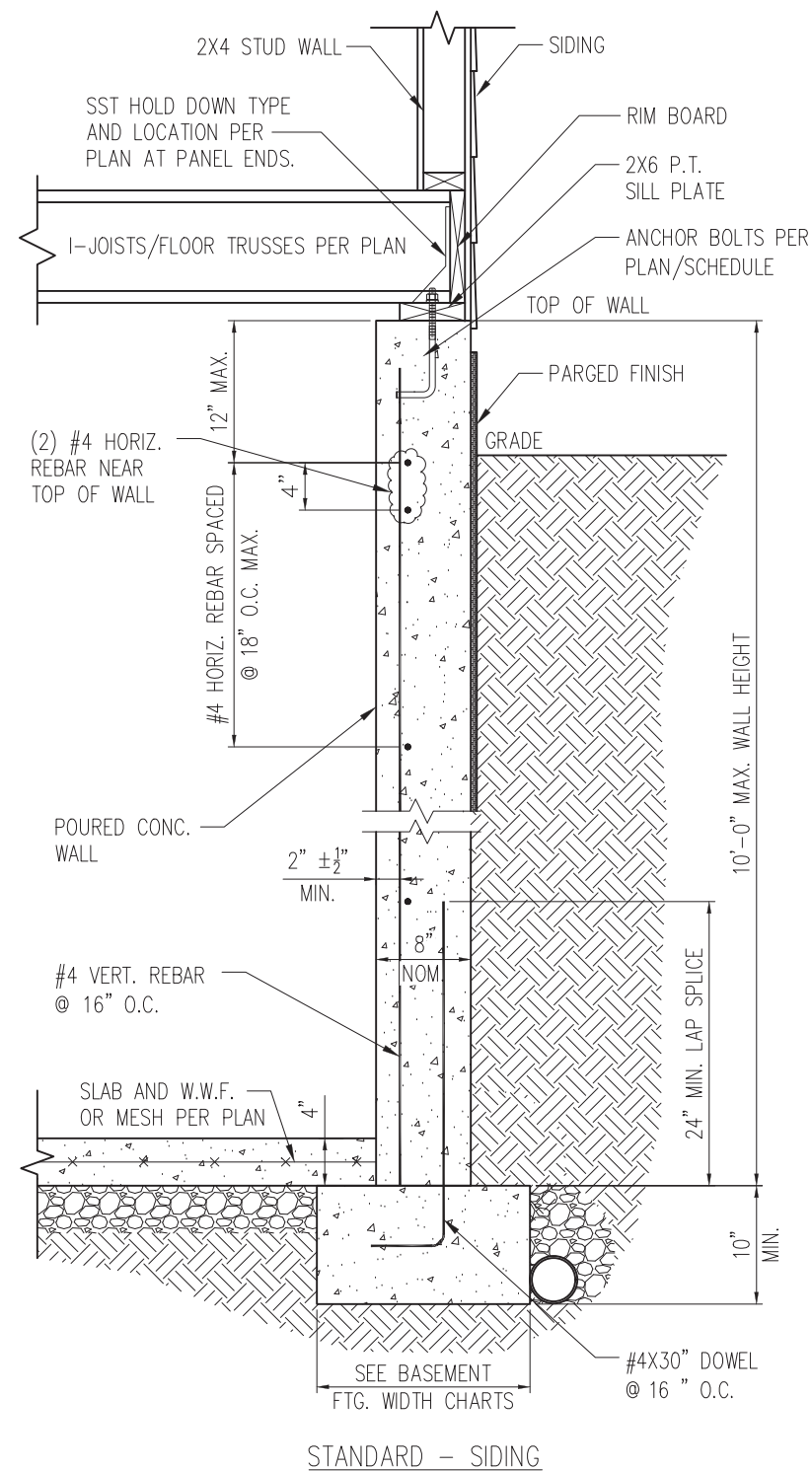

2 BASEMENT FOUNDATION WALL DETAIL W/ HOLD-DOWN
 D10f 3/4" = 1'-0"



STRUCTURAL MEMBERS ONLY

SUMMIT
 ENGINEERING LABORATORY TESTING
 3070 HAMMOND BUSINESS PLACE,
 SUITE 171, RALEIGH, NC 27603
 OFFICE: 919.380.9991
 FAX: 919.380.9993
 WWW.SUMMIT-COMPANIES.COM

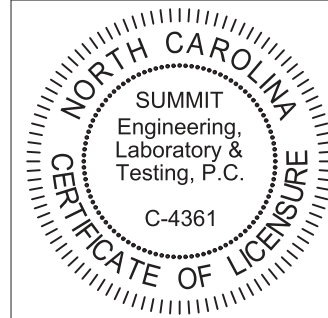

PROJECT
Standard Details
Framing Details - Bracing
 CLIENT
Smith Douglas Homes
 110 Village Trail, Suite 215
 Woodstock, GA 30188

CURRENT DRAWING
 DATE: 2/18/20
 SCALE: NTS
 PROJECT #: 3832
 DRAWN BY: LBV
 CHECKED BY: WAJ

| NO. | DATE | PROJECT # |
|-----|--------|-----------|
| 0 | 1/7/16 | 3832 |

REFER TO COVER SHEET FOR A COMPLETE LIST OF REVISIONS

SHEET
D10f

TRUSS TO WALL CONNECTIONS, IF SHOWN, ARE FOR UPLIFT ONLY AND DO NOT CONSIDER LATERAL LOADS. ALL CONNECTORS ON THIS PROJECT ARE TO BE INSTALLED PER THE CONNECTOR MANUFACTURER'S SPECIFICATIONS. ALL CONNECTORS SHOWN THAT ARE NOT "TRUSS TO TRUSS" ARE SUGGESTIONS ONLY AND ARE TO BE VERIFIED BY THE BUILDING DESIGNER OR ENGINEER OF RECORD FOR SUITABILITY TO THIS PARTICULAR PROJECT. UFP MID-ATLANTIC, LLC ACCEPTS NO RESPONSIBILITY FOR THE SPECIFIC APPLICATION OR SUITABILITY OF ANY CONNECTOR THAT IS NOT "TRUSS TO TRUSS" AS THEY APPLY TO THIS SPECIFIC STRUCTURE.

71016534 6 CANE MILL

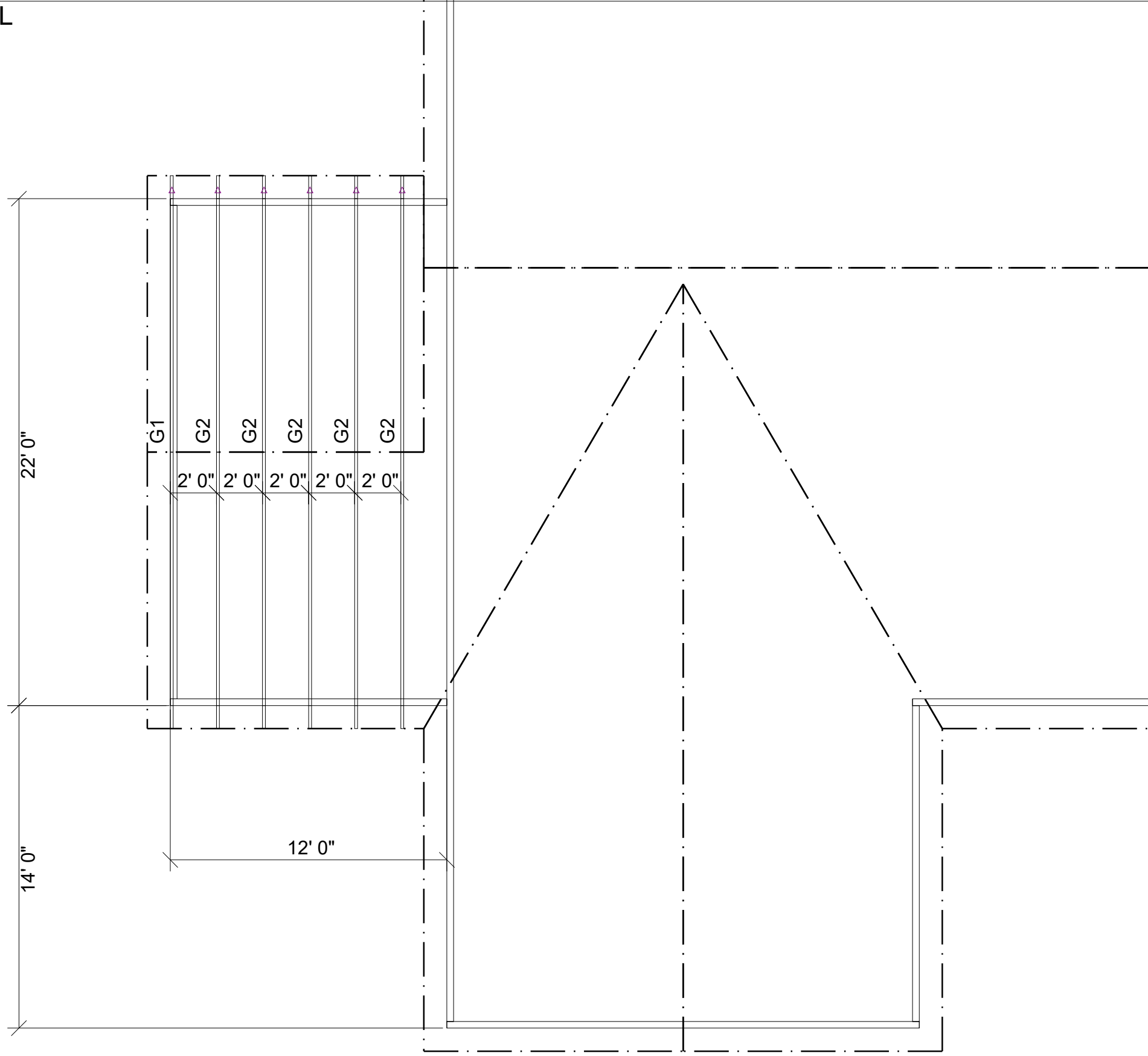

VINNINGS 3RD CAR GARAGE

ROOF AREA: 2293.26 RIDGE LINE: 76.79 VALLEY LINES: 50 HIP LINES: 0 Indicates Left End of Truss

| | |
|-----------------|-----------------|
| CUSTOMER | SMITH DOUGLAS |
| Job Name | VINNINGS GARAGE |
| Date: | 10-5-20 |
| Scale: | NTS |
| Revision Date1: | |
| Revision Date2: | |
| Checked By: | |
| Quote Number | MASTER |

NOTES: THIS DRAWING IS THE PROPERTY OF UFP MID-ATLANTIC, LLC. IT IS TO BE USED FOR THE PROJECT ONLY AND IS NOT TO BE REPRODUCED OR COPIED IN ANY MANNER WITHOUT THE WRITTEN PERMISSION OF UFP MID-ATLANTIC, LLC. THIS DRAWING MUST BE USED IN CONJUNCTION WITH ALL OTHER TECHNICAL DRAWINGS SUPPLIED BY UFP MID-ATLANTIC, LLC AND BRACING WOOD TRUSSES, COMMENTARY AND RECOMMENDATIONS. UFP MID-ATLANTIC, LLC IS NOT RESPONSIBLE FOR THE DESIGN OF ANY STRUCTURE OR TRUSSES. (FPI) IS LOCATED AT 683 DONOFRIO DR. SUITE 200 MADISON, WI 53719 (608) 833-5800

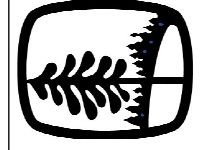

UFP MID-ATLANTIC, LLC
A UNIVERSAL FOREST PRODUCTS COMPANY
BURLINGTON, NC PHONE (800) 476-9356
CHESAPEAKE, VA PHONE (800) 476-3190
CONWAY, SC PHONE (800) 397-9572
JEFFERSON GA PHONE (800) 648-4038
PEARISBURG, VA PHONE (800) 397-9571

This layout is not an engineered drawing. This drawing was created to establish truss placement only. It is the responsibility of the builder to provide adequate support for all the elements shown in this drawing.

TRUSS TO WALL CONNECTIONS, IF SHOWN, ARE FOR UPLIFT ONLY AND DO NOT CONSIDER LATERAL LOADS. ALL CONNECTORS ON THIS PROJECT ARE TO BE INSTALLED PER THE CONNECTOR MANUFACTURER'S SPECIFICATIONS. ALL CONNECTORS SHOWN THAT ARE NOT "TRUSS TO TRUSS" ARE SUGGESTIONS ONLY AND ARE TO BE VERIFIED BY THE BUILDING DESIGNER OR ENGINEER OF RECORD FOR SUITABILITY TO THIS PARTICULAR PROJECT. UFP MID-ATLANTIC, LLC, ACCEPTS NO RESPONSIBILITY FOR THE SPECIFIC APPLICATION OR SUITABILITY OF ANY CONNECTOR THAT IS NOT "TRUSS TO TRUSS" AS THEY APPLY TO THIS SPECIFIC STRUCTURE.

VININGS BEH RANCH

| Hatch Legend | |
|----------------|--|
| HVAC / STORAGE | |
| OPT MSTR TRAY | |

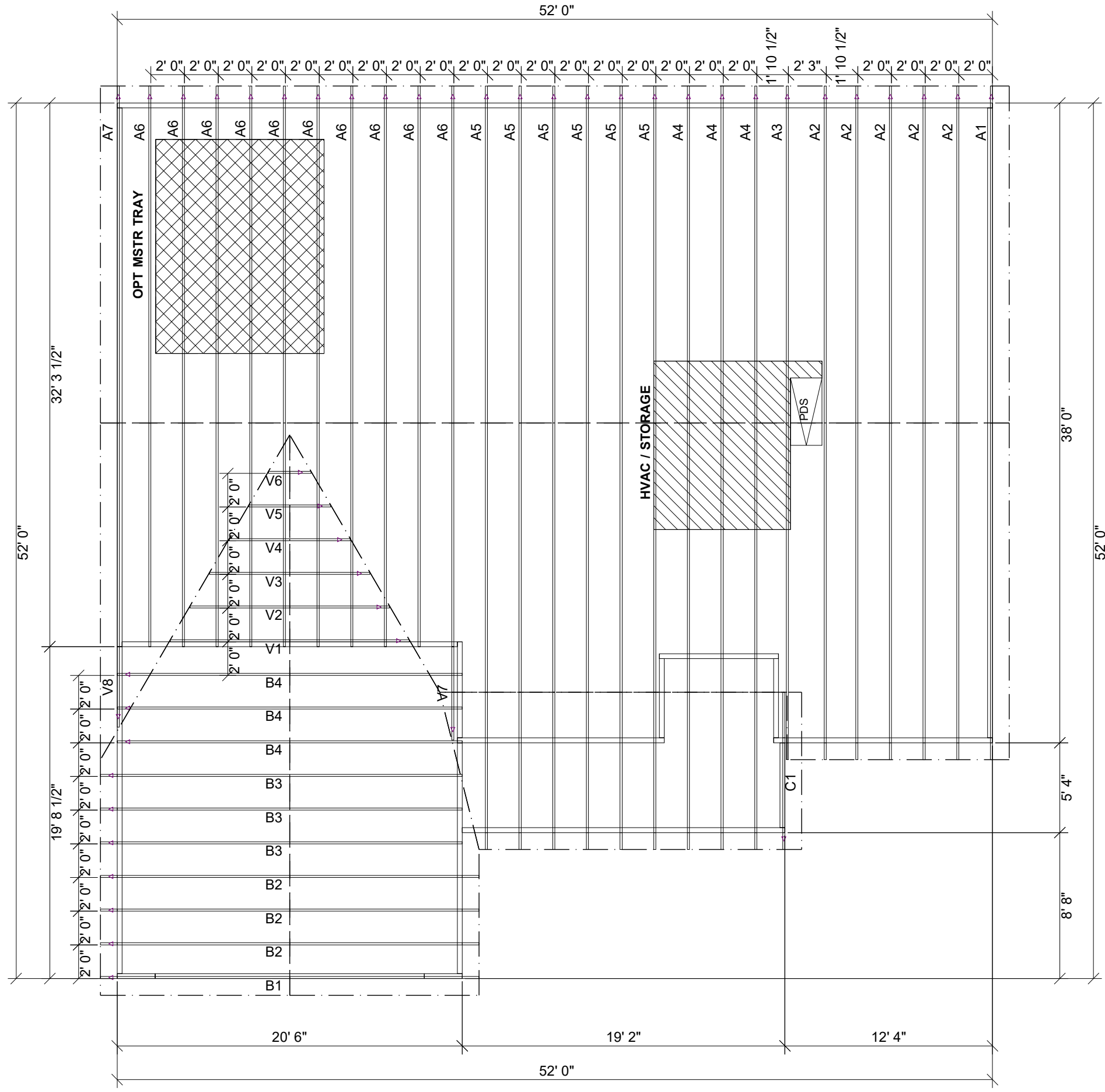

ROOF AREA: 3098.48 ft²_RIDGE LINE: 87.29 ft _ VALLEY LINES: 54.72 _ HIP LINES: 0 _ Indicates Left End of Truss

| | |
|-----------------|-------------------|
| Customer | SMITH DOUGLAS |
| Job Name | VININGS BEH RANCH |
| Date: | 9-11-20 |
| Scale: | NTS |
| Revision Date1: | |
| Revision Date2: | |
| Checked By: | |
| Quote Number | MASTER |

NOTES: THIS DRAWING IS THE PROPERTY OF UFP MID-ATLANTIC, LLC. IT IS TO BE USED ONLY FOR THE PROJECT AND NOT BE REPRODUCED OR COPIED FOR ANY OTHER PROJECT. THIS DRAWING MUST BE USED IN CONJUNCTION WITH ALL OTHER TECHNICAL DRAWINGS SUPPLIED BY UFP MID-ATLANTIC, LLC AND BRACING WOOD TRUSSES, COMMENTARY AND RECOMMENDATIONS. UFP MID-ATLANTIC, LLC IS AN EQUAL OPPORTUNITY EMPLOYER. UFP MID-ATLANTIC, LLC IS LOCATED AT 683 DONOFRIO DR., SUITE 200 MADISON, VA 5719 (666) 853-5800

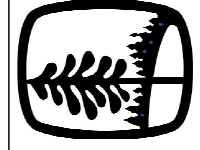

UFP MID-ATLANTIC, LLC
 A UNIVERSAL FOREST PRODUCTS COMPANY
 BURLINGTON, NC PHONE (800) 476-9356
 CHESAPEAKE, VA PHONE (800) 476-3190
 CONWAY, SC PHONE (800) 397-9572
 JEFFERSON GA PHONE (800) 648-4038
 PEARISBURG, VA PHONE (800) 397-9571

1. TEMPORARY BRACING TO BE INSTALLED W/T.P.I. STANDARD BCS-B1.
 2. SEE ENGINEERED DRAWING FOR PERMANENT BRACING MINIMUM REQUIREMENTS.
 3. FRAMER TO VERIFY ALL DIMENSIONS, DROP, & RISE LOCATIONS PRIOR TO TRUSS PLACEMENT.
 4. BLDG/FRAMER RESPONSIBLE FOR ADJUSTMENT OF TRUSS SPACING TO MISS PLUMBING DROPS, UNLESS NOTED OTHERWISE.
 This layout is not an engineered drawing. This drawing was created to establish truss placement only. It is the responsibility of the builder to provide adequate support for all the elements shown in this drawing.