

Harnett County Department of Public Health Improvement Permit

A building permit cannot be issued with only an Improvement Permit

PROPERTY LOCATION: 120 Beechleaf

ISSUED TO: Southeastern Construction SUBDIVISION _____ LOT # _____

NEW REPAIR EXPANSION Site Improvements required prior to Construction Authorization Issuance: _____

Type of Structure: SFD (47'x36')

Proposed Wastewater System Type: Pump to 25% Reduction

Projected Daily Flow: 480 GPD

Number of bedrooms: 4 Number of Occupants: 8 max

Basement Yes No

Pump Required: Yes No May be required based on final location and elevations of facilities

Type of Water Supply: Community Public Well Distance from well _____ feet

Permit conditions: _____ Permit valid for: Five years No expiration

Authorized State Agent: _____ Date: 4/19/21 SEE ATTACHED SITE SKETCH

The issuance of this permit by the Health Department in no way guarantees the issuance of other permits. The permit holder is responsible for checking with appropriate governing bodies in meeting their requirements. This site is subject to revocation if the site plan, plat, or the intended use changes. The Improvement Permit shall not be affected by a change in ownership of the site. This permit is subject to compliance with the provisions of the Laws and Rules for Sewage Treatment and Disposal and to conditions of this permit.

Construction Authorization (Required for Building Permit)

The construction and installation requirements of Rules .1950, .1952, .1954, .1955, .1956, .1957, 1958, and .1959 are incorporated by references into this permit and shall be met. Systems shall be installed in accordance with the attached system layout.

ISSUED TO: Southeastern Construction PROPERTY LOCATION: 120 Beechleaf

SUBDIVISION _____ LOT # _____

Facility Type: SFD (47'x36') New Expansion Repair

Basement? Yes No Basement Fixtures? Yes No

Type of Wastewater System** Pump to 25% Reduction System (Initial) Wastewater Flow: 480 GPD

(See note below, if applicable Pump to 25% Red Sys (Repair)

<u>Installation Requirements/Conditions</u>	Number of trenches <u>5</u>	
Septic Tank Size <u>1000</u> gallons	Exact length of each trench <u>80</u> feet	Trench Spacing: <u>9</u> Feet on Center
Pump Tank Size <u>1000</u> gallons	Trenches shall be installed on contour at a Maximum Trench Depth of: <u>12-16</u> inches (Trench bottoms shall be level to +/-1/4" in all directions)	Soil Cover: <u>6</u> inches (Maximum soil cover shall not exceed 36" above the trench bottom)
Pump Requirements: _____ ft. TDH vs. _____ GPM		_____ inches below pipe Aggregate Depth: _____ inches above pipe _____ inches total

Conditions: Minimum of 6" of cover required over drain field.

**WATER LINES (INCLUDING IRRIGATION) MUST BE 10FT. FROM ANY PART OF SEPTIC SYSTEM OR REPAIR AREA.
NO UTILITIES ALLOWED IN INITIAL OR REPAIR DRAIN FIELD AREA.**

***If applicable: I understand the system type specified is different from the type specified on the application. I accept the specifications of this permit.*

Owner/Legal Representative Signature: _____ Date: _____

This Construction Authorization is subject to revocation if the site plan, plat, or the intended use changes. The Construction Authorization shall not be transferred when there is a change in ownership of the site. This Construction Authorization is subject to compliance with the provisions of the Laws and Rules for Sewage Treatment and Disposal and to the conditions of this permit. SEE ATTACHED SITE SKETCH

Authorized State Agent: _____ Date: 4/19/21

Construction Authorization Expiration Date: 4/19/26

Application # SFD2102-0107

Harnett County Department of Public Health Site Sketch

Property Location: 120 Beechleaf
Issued To: Southeastern Construction Subdivision _____ Lot # _____

Authorized State Agent: RENS OLIVER TOLKSDORF Date: 4/19/21

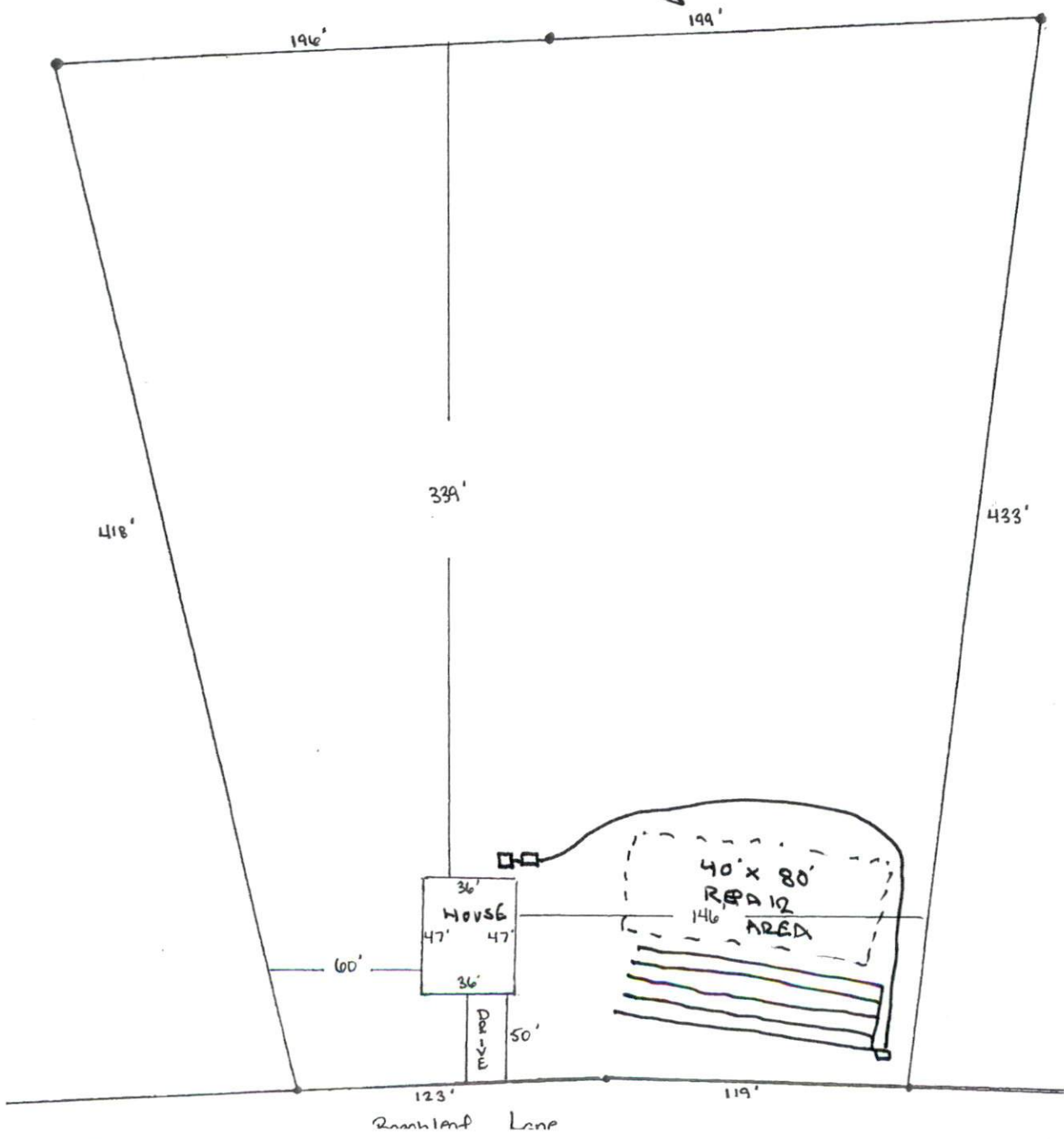

This drawing is for illustrative purposes only. System installation must meet all pertinent laws, rules, and regulations.