

First Floor Layout

Red Door Homes Hanover

Products				
PlotID	Net Qty	Product	Length	Plies
1	3	11-7/8" BCI® 4500s-1.8	36' 0"	1
2	15	11-7/8" BCI® 4500s-1.8	30' 0"	1
3	1	11-7/8" BCI® 4500s-1.8	29' 0"	1
4	13	11-7/8" BCI® 4500s-1.8	22' 0"	1
5	15	11-7/8" BCI® 4500s-1.8	14' 0"	1
6	1	11-7/8" BCI® 4500s-1.8	13' 0"	1
7	1	11-7/8" BCI® 4500s-1.8	8' 0"	1
8	1	11-7/8" BCI® 4500s-1.8	6' 0"	1
Rm-1	9	1" x 11-7/8" BC RIM BOARD OSB	12' 0"	1
Bk1	65	11-7/8" BCI® 4500s-1.8	2' 0"	1

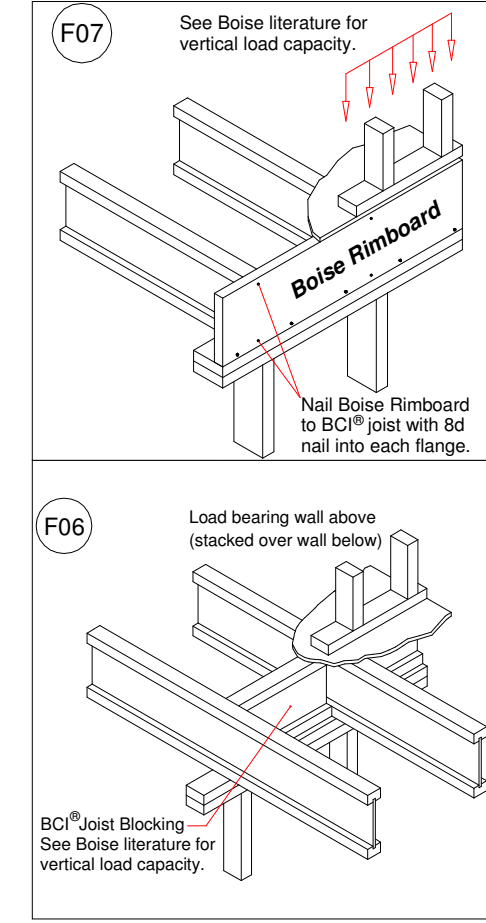

All I-Joist and Versa-Lam Beams
Must be Installed per The
Boise Cascade Installation Guide!

Squash Blocks Required
Under The Ends Of All LVL
And Point Loads For Load
Transfer - See Details

Revisions:	BY:
<p>SALES PRESENTATION DRAWING No structural or dimensional check has been made of this design drawings of the building, therefore, purchaser is to check and approve all dimensions, quantities, loads, details carefully. This drawing has not been check by Boise Engineering.</p>	
<p>Red Door Homes Hanover 84 Lumber EWP</p>	
BC FRAMER II	
Plan Date: 8/9/2019	
Structural Date: 11/17/2020	
By: GAT	
Sheet: 1/4	