

Trenco  
818 Soundside Rd  
Edenton, NC 27932

Re: Master\_RT130  
MCKEE; NELSON

The truss drawing(s) referenced below have been prepared by Truss Engineering Co. under my direct supervision based on the parameters provided by Builders FirstSource-Apex,NC.

Pages or sheets covered by this seal: I44818016 thru I44818052

My license renewal date for the state of North Carolina is December 31, 2021.

North Carolina COA: C-0844



February 15,2021

Sevier, Scott

**IMPORTANT NOTE:** The seal on these truss component designs is a certification that the engineer named is licensed in the jurisdiction(s) identified and that the designs comply with ANSI/TPI 1. These designs are based upon parameters shown (e.g., loads, supports, dimensions, shapes and design codes), which were given to MiTek or TRENCO. Any project specific information included is for MiTek's or TRENCO's customers file reference purpose only, and was not taken into account in the preparation of these designs. MiTek or TRENCO has not independently verified the applicability of the design parameters or the designs for any particular building. Before use, the building designer should verify applicability of design parameters and properly incorporate these designs into the overall building design per ANSI/TPI 1, Chapter 2.

Job MASTER_RT130	Truss AT02	Truss Type ATTIC	Qty 1	Ply 1	MCKEE; NELSON	144818016
---------------------	---------------	---------------------	----------	----------	---------------	-----------

Builders FirstSource (Apex, NC), Apex, NC - 27523, 8.240 s Mar 9 2020 MiTek Industries, Inc. Mon Feb 15 14:19:53 2021 Page 1

ID:f0X\_NZYyOMto?npzE4iXpZyeg2c-AmNf32wf2R?NXv5lcMo9gdRu2fAMYUfZd7VMLBzksuK



5x6 =

Scale = 1:78.9

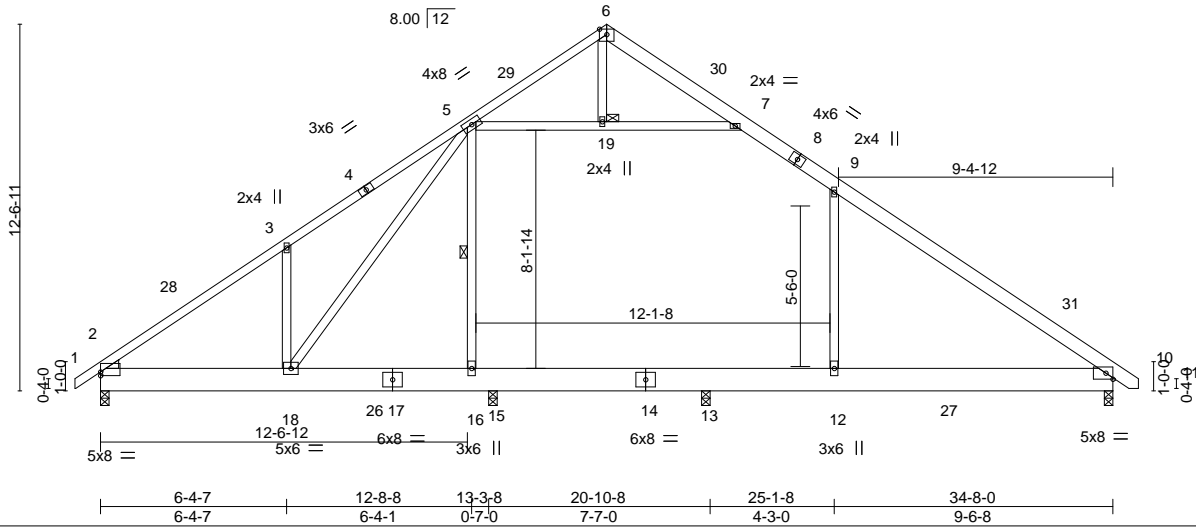

Plate Offsets (X,Y)--	[2:0-0,0,0-1-8]
-----------------------	-----------------

LOADING (psf)	SPACING-	CSI.	DEFL.	PLATES	GRIP
TCLL 20.0	2-0-0	TC 0.43	in (loc) l/defl L/d	MT20	244/190
TCDL 10.0	Plate Grip DOL 1.15	BC 0.32	Vert(LL) -0.10 12-25 >999 360		
BCLL 0.0 *	Lumber DOL 1.15	WB 0.62	Vert(CT) -0.20 12-25 >847 240		
BCDL 10.0	Rep Stress Incr YES	Matrix-MS	Horz(CT) 0.01 10 n/a n/a		
	Code IRC2015/TPI2014		Wind(LL) 0.11 12-25 >999 240	Weight: 282 lb	FT = 20%

**LUMBER-**  
TOP CHORD 2x4 SP No.2 \*Except\*  
6-8,8-11: 2x6 SP No.2  
BOT CHORD 2x10 SP DSS  
WEBS 2x4 SP No.2 \*Except\*  
5-18,3-18,6-19: 2x4 SP No.3  
**WEDGE**  
Left: 2x4 SP No.3  
**BRACING-**  
TOP CHORD Structural wood sheathing directly applied or 4-10-6 oc purlins.  
BOT CHORD Rigid ceiling directly applied or 10-0-0 oc bracing.  
WEBS 1 Row at midpt 5-16  
JOINTS 1 Brace at Jt(s): 19

**REACTIONS.** All bearings 0-3-8.  
(lb) - Max Horz 2=306(LC 11)  
Max Uplift All uplift 100 lb or less at joint(s) 2, 10, 13 except 15=148(LC 9)  
Max Grav All reactions 250 lb or less at joint(s) except 2=1036(LC 1), 10=1035(LC 21), 13=1437(LC 21), 15=895(LC 20)

**FORCES.** (lb) - Max. Comp./Max. Ten. - All forces 250 (lb) or less except when shown.  
TOP CHORD 2-3=-1321/172, 3-5=-1274/282, 5-6=-363/70, 6-7=-364/72, 7-9=-885/194, 9-10=-982/0  
BOT CHORD 2-18=-55/1036, 16-18=0/698, 15-16=0/685, 13-15=0/685, 12-13=0/685, 10-12=0/685  
WEBS 5-19=-576/236, 7-19=-579/234, 5-16=-531/315, 9-12=-416/200, 5-18=-290/593,  
3-18=-397/281

- NOTES-**
- Unbalanced roof live loads have been considered for this design.
  - Wind: ASCE 7-10; Vult=130mph (3-second gust) Vasd=103mph; TCDL=6.0psf; BCDL=6.0psf; h=32ft; Cat. II; Exp B; Enclosed; MWFRS (envelope) gable end zone and C-C Exterior(2) -0-10-6 to 2-1-10, Interior(1) 2-1-10 to 17-4-0, Exterior(2) 17-4-0 to 20-4-0, Interior(1) 20-4-0 to 35-4-9 zone; cantilever left and right exposed; end vertical left and right exposed; C-C for members and forces & MWFRS for reactions shown; Lumber DOL=1.60 plate grip DOL=1.60
  - This truss has been designed for a 10.0 psf bottom chord live load nonconcurrent with any other live loads.
  - \* This truss has been designed for a live load of 20.0psf on the bottom chord in all areas where a rectangle 3-6-0 tall by 2-0-0 wide will fit between the bottom chord and any other members, with BCDL = 10.0psf.
  - Ceiling dead load (5.0 psf) on member(s). 7-9, 5-19, 7-19; Wall dead load (5.0psf) on member(s).5-16, 9-12
  - Bottom chord live load (40.0 psf) and additional bottom chord dead load (5.0 psf) applied only to room. 15-16, 13-15, 12-13
  - Provide mechanical connection (by others) of truss to bearing plate capable of withstanding 100 lb uplift at joint(s) 2, 10, 13 except (jt=lb) 15=148.
  - Attic room checked for L/360 deflection.



February 15, 2021

Job MASTER_RT130	Truss AT03	Truss Type ATTIC	Qty 1	Ply 1	MCKEE; NELSON	144818017
---------------------	---------------	---------------------	----------	----------	---------------	-----------

Builders FirstSource (Apex, NC), Apex, NC - 27523, 8.240 s Mar 9 2020 MiTek Industries, Inc. Mon Feb 15 14:19:54 2021 Page 1

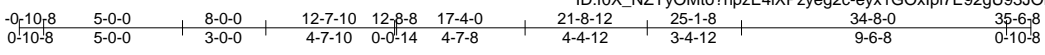

5x6 =

Scale = 1:82.9

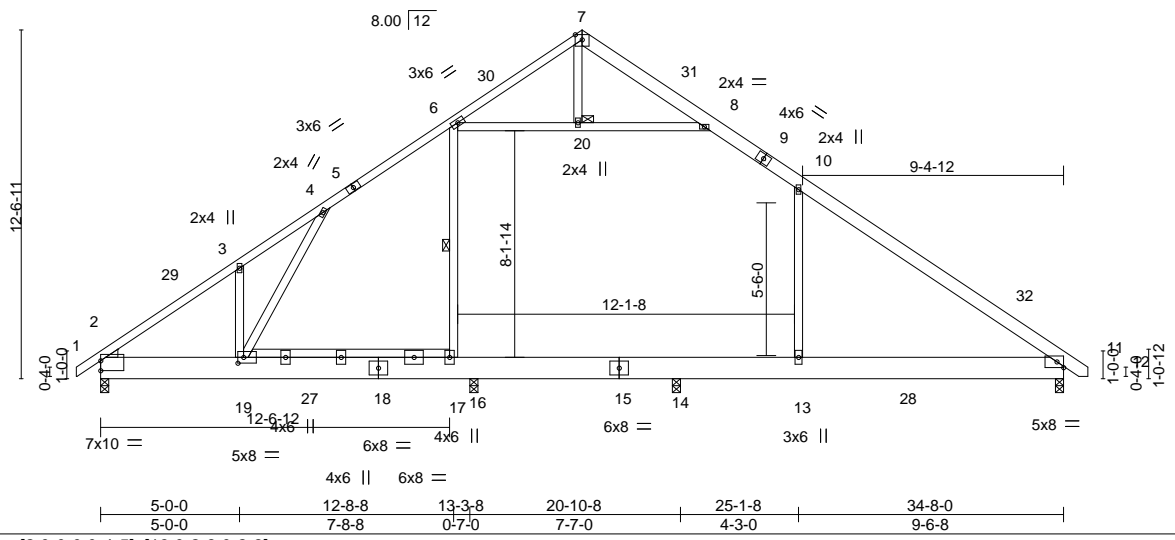

Plate Offsets (X,Y)--	[2:0-0-0,0-4-5], [19:0-2-8,0-2-8]
-----------------------	-----------------------------------

LOADING (psf)	SPACING-	2-2-8	CSI.	DEFL.	in (loc)	l/defl	L/d	PLATES	GRIP
TCLL 20.0	Plate Grip DOL	1.15	TC 0.58	Vert(LL)	-0.11 13-26	>999	360	MT20	244/190
TCDL 10.0	Lumber DOL	1.15	BC 0.44	Vert(CT)	-0.21 13-26	>781	240		
BCLL 0.0 *	Rep Stress Incr	NO	WB 0.30	Horz(CT)	0.02 2	n/a	n/a		
BCDL 10.0	Code IRC2015/TPI2014		Matrix-MS	Wind(LL)	0.13 17-19	>999	240	Weight: 286 lb	FT = 20%

LUMBER-	BRACING-
TOP CHORD 2x4 SP No.1 *Except* 7-9,9-12: 2x6 SP No.2	TOP CHORD Structural wood sheathing directly applied or 5-7-5 oc purlins.
BOT CHORD 2x10 SP DSS *Except* 17-19: 2x4 SP No.2	BOT CHORD Rigid ceiling directly applied or 10-0-0 oc bracing, Except: 8-2-13 oc bracing: 17-19.
WEBS 2x4 SP No.2 *Except* 4-19,7-20,3-19: 2x4 SP No.3	WEBS 1 Row at midpt 6-17
WEDGE Left: 2x4 SP No.3	JOINTS 1 Brace at Jt(s): 20

**REACTIONS.** All bearings 0-3-8.  
 (lb) - Max Horz 2=338(LC 11)  
 Max Uplift All uplift 100 lb or less at joint(s) 14 except 2=-105(LC 13), 11=-100(LC 13), 16=-206(LC 12)  
 Max Grav All reactions 250 lb or less at joint(s) except 2=1162(LC 1), 11=1197(LC 21), 14=1462(LC 21), 16=1145(LC 20)

**FORCES.** (lb) - Max. Comp./Max. Ten. - All forces 250 (lb) or less except when shown.  
 TOP CHORD 2-3=-1228/104, 3-4=-1201/183, 4-6=-1170/300, 6-7=-377/73, 7-8=-385/72,  
 8-10=-1051/232, 10-11=-1207/68  
 BOT CHORD 2-19=0/807, 17-19=0/874, 16-17=0/872, 14-16=0/872, 13-14=0/872, 11-13=0/872  
 WEBS 6-20=-741/279, 8-20=-745/278, 6-17=-284/234, 10-13=-430/211, 3-19=-394/265

- NOTES-**
- 1) Unbalanced roof live loads have been considered for this design.
  - 2) Wind: ASCE 7-10; Vult=130mph (3-second gust) Vasd=103mph; TCDL=6.0psf; BCDL=6.0psf; h=32ft; Cat. II; Exp B; Enclosed; MWFRS (envelope) gable end zone and C-C Exterior(2) -0-10-6 to 2-1-10, Interior(1) 2-1-10 to 17-4-0, Exterior(2) 17-4-0 to 20-4-0, Interior(1) 20-4-0 to 35-4-9 zone; cantilever left and right exposed ; end vertical left and right exposed;C-C for members and forces & MWFRS for reactions shown; Lumber DOL=1.60 plate grip DOL=1.60
  - 3) This truss has been designed for a 10.0 psf bottom chord live load nonconcurrent with any other live loads.
  - 4) \* This truss has been designed for a live load of 20.0psf on the bottom chord in all areas where a rectangle 3-6-0 tall by 2-0-0 wide will fit between the bottom chord and any other members, with BCDL = 10.0psf.
  - 5) Ceiling dead load (5.0 psf) on member(s). 8-10, 6-20, 8-20; Wall dead load (5.0psf) on member(s).6-17, 10-13
  - 6) Bottom chord live load (40.0 psf) and additional bottom chord dead load (5.0 psf) applied only to room. 16-17, 14-16, 13-14
  - 7) Provide mechanical connection (by others) of truss to bearing plate capable of withstanding 100 lb uplift at joint(s) 14 except (jt=lb) 2=105, 11=100, 16=206.
  - 8) Attic room checked for L/360 deflection.



February 15, 2021

**WARNING - Verify design parameters and READ NOTES ON THIS AND INCLUDED MITEK REFERENCE PAGE MII-7473 rev. 5/19/2020 BEFORE USE.**  
 Design valid for use only with MiTek® connectors. This design is based only upon parameters shown, and is for an individual building component, not a truss system. Before use, the building designer must verify the applicability of design parameters and properly incorporate this design into the overall building design. Bracing indicated is to prevent buckling of individual truss web and/or chord members only. Additional temporary and permanent bracing is always required for stability and to prevent collapse with possible personal injury and property damage. For general guidance regarding the fabrication, storage, delivery, erection and bracing of trusses and truss systems, see **ANSI/TPI1 Quality Criteria, DSB-89 and BCSI Building Component Safety Information** available from Truss Plate Institute, 2670 Crain Highway, Suite 203 Waldorf, MD 20601

**ENGINEERING BY**  
**TRENCO**  
 A MiTek Affiliate

818 Soundside Road  
 Edenton, NC 27932

Job MASTER_RT130	Truss AT04	Truss Type ATTIC	Qty 1	Ply 1	MCKEE; NELSON	144818018
---------------------	---------------	---------------------	----------	----------	---------------	-----------

Builders FirstSource (Apex, NC), Apex, NC - 27523, 8.240 s Mar 9 2020 MiTek Industries, Inc. Mon Feb 15 14:19:55 2021 Page 1

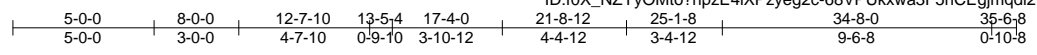

5x6 =

Scale = 1:81.6

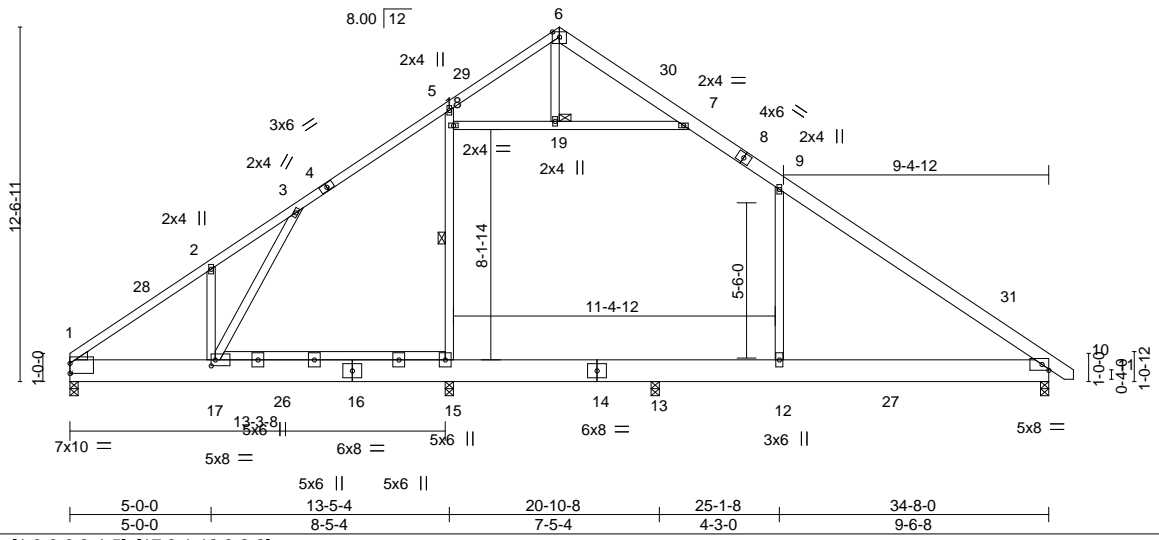

Plate Offsets (X,Y)--	[1:0-0,0,0-4-5], [17:0-1-12,0-2-8]
-----------------------	------------------------------------

LOADING (psf)	SPACING-	CSI.	DEFL.	PLATES	GRIP
TCLL 20.0	2-4-0	TC 0.58	in (loc) l/defl L/d	MT20	244/190
TCDL 10.0	Plate Grip DOL 1.15	BC 0.53	Vert(LL) -0.14 12-25 >999 360		
BCLL 0.0 *	Lumber DOL 1.15	WB 0.71	Vert(CT) -0.27 12-25 >618 240		
BCDL 10.0	Rep Stress Incr NO	Matrix-MS	Horz(CT) 0.02 1 n/a n/a		
	Code IRC2015/TPI2014		Wind(LL) 0.17 15-17 >966 240	Weight: 285 lb	FT = 20%

LUMBER-	BRACING-
TOP CHORD 2x4 SP No.1 *Except* 6-8,8-11: 2x6 SP No.2	TOP CHORD Structural wood sheathing directly applied or 6-0-0 oc purlins.
BOT CHORD 2x10 SP DSS *Except* 15-17: 2x4 SP No.2	BOT CHORD Rigid ceiling directly applied or 6-3-1 oc bracing.
WEBS 2x4 SP No.2 *Except* 3-17,6-19,2-17: 2x4 SP No.3	WEBS 1 Row at midpt 15-18
WEDGE Left: 2x4 SP No.3	JOINTS 1 Brace at Jt(s): 19

**REACTIONS.** All bearings 0-3-8.  
 (lb) - Max Horz 1=-352(LC 8)  
 Max Uplift All uplift 100 lb or less at joint(s) 1, 10 except 15=-324(LC 12), 13=-116(LC 13)  
 Max Grav All reactions 250 lb or less at joint(s) except 1=928(LC 1), 15=1434(LC 20), 10=1046(LC 21), 13=1730(LC 21)

**FORCES.** (lb) - Max. Comp./Max. Ten. - All forces 250 (lb) or less except when shown.

TOP CHORD	WEBS
1-2=-818/122, 2-3=-793/84, 3-5=-803/167, 5-6=-412/106, 6-7=-393/67, 7-9=-808/124, 9-10=-877/0	18-19=-379/147, 7-19=-384/146, 15-18=-442/266, 5-18=-344/279, 9-12=-618/296, 3-17=-269/227, 2-17=-411/272

- NOTES-**
- 1) Unbalanced roof live loads have been considered for this design.
  - 2) Wind: ASCE 7-10; Vult=130mph (3-second gust) Vasd=103mph; TCDL=6.0psf; BCDL=6.0psf; h=32ft; Cat. II; Exp B; Enclosed; MWFRS (envelope) gable end zone and C-C Exterior(2) 0-0-0 to 3-0-0, Interior(1) 3-0-0 to 17-4-0, Exterior(2) 17-4-0 to 20-4-0, Interior(1) 20-4-0 to 35-4-9 zone; cantilever left and right exposed; end vertical left and right exposed; C-C for members and forces & MWFRS for reactions shown; Lumber DOL=1.60 plate grip DOL=1.60
  - 3) This truss has been designed for a 10.0 psf bottom chord live load nonconcurrent with any other live loads.
  - 4) \* This truss has been designed for a live load of 20.0psf on the bottom chord in all areas where a rectangle 3-6-0 tall by 2-0-0 wide will fit between the bottom chord and any other members, with BCDL = 10.0psf.
  - 5) Ceiling dead load (5.0 psf) on member(s). 7-9, 18-19, 7-19; Wall dead load (5.0psf) on member(s). 15-18, 9-12
  - 6) Bottom chord live load (40.0 psf) and additional bottom chord dead load (5.0 psf) applied only to room. 13-15, 12-13
  - 7) Provide mechanical connection (by others) of truss to bearing plate capable of withstanding 100 lb uplift at joint(s) 1, 10 except (jt=lb) 15=324, 13=116.
  - 8) Attic room checked for L/360 deflection.



February 15, 2021

**WARNING - Verify design parameters and READ NOTES ON THIS AND INCLUDED MITEK REFERENCE PAGE MII-7473 rev. 5/19/2020 BEFORE USE.**

Design valid for use only with MiTek® connectors. This design is based only upon parameters shown, and is for an individual building component, not a truss system. Before use, the building designer must verify the applicability of design parameters and properly incorporate this design into the overall building design. Bracing indicated is to prevent buckling of individual truss web and/or chord members only. Additional temporary and permanent bracing is always required for stability and to prevent collapse with possible personal injury and property damage. For general guidance regarding the fabrication, storage, delivery, erection and bracing of trusses and truss systems, see **ANSI/TPI1 Quality Criteria, DSB-89 and BCSI Building Component Safety Information** available from Truss Plate Institute, 2670 Crain Highway, Suite 203 Waldorf, MD 20601

**ENGINEERING BY**  
**TRENCO**  
 A MiTek Affiliate

818 Soundside Road  
 Edenton, NC 27932

Job MASTER_RT130	Truss AT05GR	Truss Type ATTIC	Qty 1	Ply 1	MCKEE; NELSON	144818019
---------------------	-----------------	---------------------	----------	----------	---------------	-----------

Builders FirstSource (Apex, NC), Apex, NC - 27523, 8.240 s Mar 9 2020 MiTek Industries, Inc. Mon Feb 15 14:19:57 2021 Page 1

ID:f0X\_NZYyOMto?npzE4iXpZyeg2c-3Xc9vQzA6gWp0WO3rBt5rTbYLGU9UJy8YITaUyzksuG

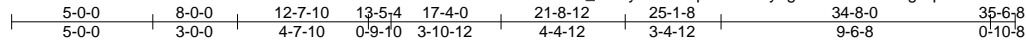

5x6 =

Scale = 1:81.6

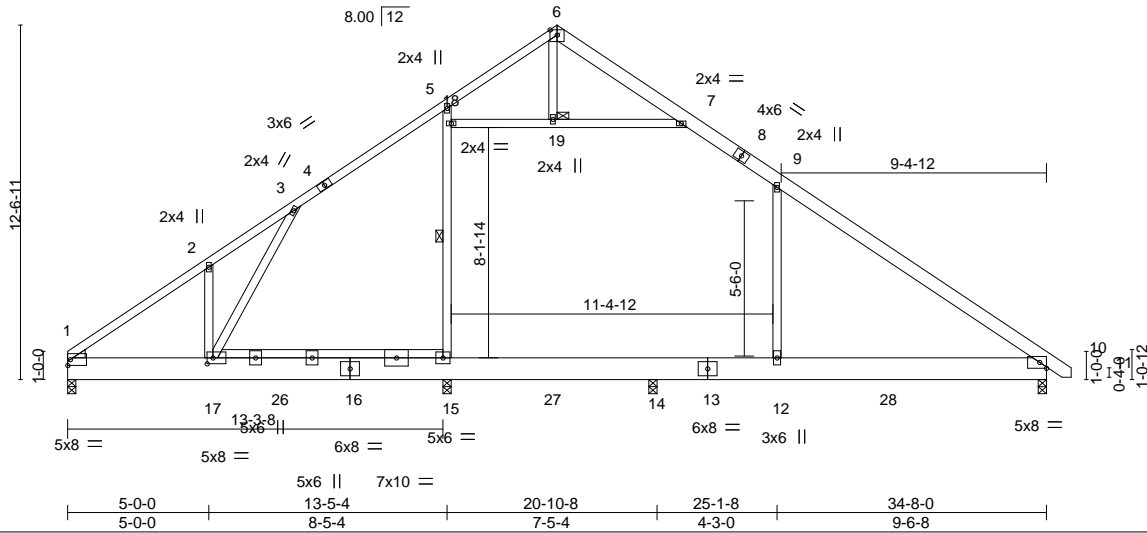

Plate Offsets (X,Y)--	[17:0-2-8,0-2-8]
-----------------------	------------------

LOADING (psf)	SPACING-	CSI.	DEFL.	PLATES	GRIP
TCLL 20.0	2-0-0	TC 0.47	in (loc) l/defl L/d	MT20	244/190
TCDL 10.0	Plate Grip DOL 1.15	BC 0.45	Vert(LL) -0.09 12-25 >999 360		
BCLL 0.0 *	Lumber DOL 1.15	WB 0.54	Vert(CT) -0.19 12-25 >899 240		
BCDL 10.0	Rep Stress Incr NO	Matrix-MS	Horz(CT) 0.02 1 n/a n/a		
	Code IRC2015/TPI2014		Wind(LL) 0.13 17 >999 240	Weight: 285 lb	FT = 20%

LUMBER-	BRACING-
TOP CHORD 2x4 SP No.1 *Except* 6-8,8-11: 2x6 SP No.2	TOP CHORD Structural wood sheathing directly applied or 6-0-0 oc purlins.
BOT CHORD 2x10 SP DSS *Except* 15-17: 2x4 SP No.2	BOT CHORD Rigid ceiling directly applied or 8-3-4 oc bracing.
WEBS 2x4 SP No.2 *Except* 3-17,6-19,2-17: 2x4 SP No.3	WEBS 1 Row at midpt 15-18
WEDGE Left: 2x4 SP No.3	JOINTS 1 Brace at Jt(s): 19

**REACTIONS.** All bearings 0-3-8.  
 (lb) - Max Horz 1=301(LC 4)  
 Max Uplift All uplift 100 lb or less at joint(s) 1, 10 except 15=366(LC 8), 14=181(LC 9)  
 Max Grav All reactions 250 lb or less at joint(s) except 1=749(LC 1), 15=2041(LC 16), 10=841(LC 1), 14=2228(LC 17)

**FORCES.** (lb) - Max. Comp./Max. Ten. - All forces 250 (lb) or less except when shown.  
 TOP CHORD 1-2=-626/105, 2-3=-595/73, 3-5=-645/138, 5-6=-356/91, 6-7=-323/48, 7-9=-671/102, 9-10=-718/0  
 BOT CHORD 1-17=0/407, 15-17=0/484, 14-15=0/493, 12-14=0/493, 10-12=0/493  
 WEBS 18-19=-268/120, 7-19=-272/120, 15-18=-387/230, 5-18=-303/240, 9-12=-567/258, 3-17=-273/199, 2-17=-335/231

- NOTES-**
- 1) Unbalanced roof live loads have been considered for this design.
  - 2) Wind: ASCE 7-10; Vult=130mph (3-second gust) Vasd=103mph; TCDL=6.0psf; BCDL=6.0psf; h=32ft; Cat. II; Exp B; Enclosed; MWFRS (envelope) gable end zone; cantilever left and right exposed; end vertical left and right exposed; Lumber DOL=1.60 plate grip DOL=1.60
  - 3) This truss has been designed for a 10.0 psf bottom chord live load nonconcurrent with any other live loads.
  - 4) \* This truss has been designed for a live load of 20.0psf on the bottom chord in all areas where a rectangle 3-6-0 tall by 2-0-0 wide will fit between the bottom chord and any other members, with BCDL = 10.0psf.
  - 5) Ceiling dead load (5.0 psf) on member(s). 7-9, 18-19, 7-19; Wall dead load (5.0psf) on member(s).15-18, 9-12
  - 6) Bottom chord live load (40.0 psf) and additional bottom chord dead load (5.0 psf) applied only to room. 14-15, 12-14
  - 7) Provide mechanical connection (by others) of truss to bearing plate capable of withstanding 100 lb uplift at joint(s) 1, 10 except (jt=lb) 15=366, 14=181.
  - 8) Hanger(s) or other connection device(s) shall be provided sufficient to support concentrated load(s) 1406 lb down and 154 lb up at 17-0-8 on bottom chord. The design/selection of such connection device(s) is the responsibility of others.
  - 9) Attic chord checked for L/360 deflection.
  - 10) In the LOAD CASE(S) section, loads applied to the face of the truss are noted as front (F) or back (B).



**LOAD CASE(S)** Standard

**WARNING - Verify design parameters and READ NOTES ON THIS AND INCLUDED MITEK REFERENCE PAGE MII-7473 rev. 5/19/2020 BEFORE USE.**  
 Design valid for use only with MiTek® connectors. This design is based only upon parameters shown, and is for an individual building component, not a truss system. Before use, the building designer must verify the applicability of design parameters and properly incorporate this design into the overall building design. Bracing indicated is to prevent buckling of individual truss web and/or chord members only. Additional temporary and permanent bracing is always required for stability and to prevent collapse with possible personal injury and property damage. For general guidance regarding the fabrication, storage, delivery, erection and bracing of trusses and truss systems, see **ANSI/TPI1 Quality Criteria, DSB-89 and BCSI Building Component Safety Information** available from Truss Plate Institute, 2670 Crain Highway, Suite 203 Waldorf, MD 20601

**ENGINEERING BY**  
**TRENCO**  
 A MiTek Affiliate  
 818 Soundside Road  
 Edenton, NC 27932

Job MASTER_RT130	Truss AT05GR	Truss Type ATTIC	Qty 1	Ply 1	MCKEE; NELSON  Job Reference (optional)	I44818019
---------------------	-----------------	---------------------	----------	----------	---	-----------

Builders FirstSource (Apex, NC), Apex, NC - 27523,

8.240 s Mar 9 2020 MiTek Industries, Inc. Mon Feb 15 14:19:57 2021 Page 2  
ID:f0X\_NZYyOMto?npzE4iXPzyeg2c-3Xc9vQzA6gWp0WO3rBt5rTbYLGU9UJy8YITaUyzksuG

**LOAD CASE(S)** Standard

1) Dead + Roof Live (balanced): Lumber Increase=1.15, Plate Increase=1.15

Uniform Loads (plf)

Vert: 15-20=-20, 12-15=-30, 12-23=-20, 1-6=-60, 6-7=-60, 7-9=-70, 9-11=-60, 7-18=-10

Drag: 15-18=-10, 9-12=-10

Concentrated Loads (lb)

Vert: 27=-800(F)

**WARNING** - Verify design parameters and READ NOTES ON THIS AND INCLUDED MITEK REFERENCE PAGE MII-7473 rev. 5/19/2020 BEFORE USE.

Design valid for use only with MiTek® connectors. This design is based only upon parameters shown, and is for an individual building component, not a truss system. Before use, the building designer must verify the applicability of design parameters and properly incorporate this design into the overall building design. Bracing indicated is to prevent buckling of individual truss web and/or chord members only. Additional temporary and permanent bracing is always required for stability and to prevent collapse with possible personal injury and property damage. For general guidance regarding the fabrication, storage, delivery, erection and bracing of trusses and truss systems, see **ANSI/TPI1 Quality Criteria, DSB-89 and BCSI Building Component**

**Safety Information** available from Truss Plate Institute, 2670 Crain Highway, Suite 203 Waldorf, MD 20601



818 Soundside Road  
Edenton, NC 27932

Job MASTER_RT130	Truss AT07	Truss Type ATTIC	Qty 1	Ply 1	MCKEE; NELSON	144818020
---------------------	---------------	---------------------	----------	----------	---------------	-----------

Builders FirstSource (Apex, NC), Apex, NC - 27523, 8.240 s Mar 9 2020 MiTek Industries, Inc. Mon Feb 15 14:19:57 2021 Page 1  
 ID:f0X\_NZYyOMto?npzE4iXPzyeg2c-3Xc9vQzA6gWp0WO3rBt5rTbaKGURUFc8YITaUyzksuG

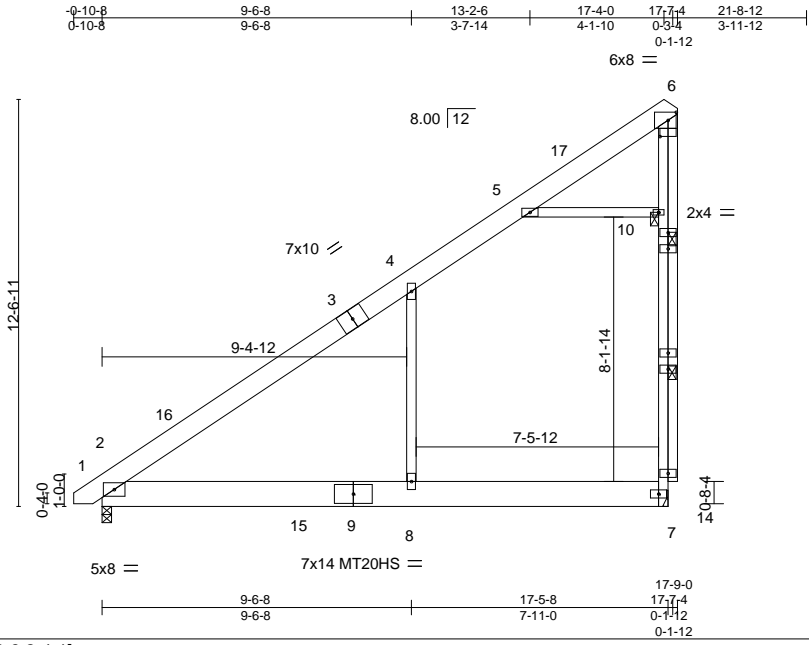

Plate Offsets (X,Y)-- [6:0-3-0,0-3-0], [10:0-0-8,2-4-1]

LOADING (psf)	SPACING-	CSI.	DEFL.	PLATES	GRIP
TCLL 20.0	1-7-3	TC 0.35	in (loc) l/defl L/d	MT20	244/190
TCDL 10.0	Plate Grip DOL 1.15	BC 0.47	Vert(LL) -0.39 8 >537 360	MT20HS	187/143
BCLL 0.0 *	Lumber DOL 1.15	WB 0.82	Vert(CT) -0.71 8 >293 240		
BCDL 10.0	Rep Stress Incr YES	Matrix-MS	Horz(CT) 0.03 2 n/a n/a		
	Code IRC2015/TPI2014		Wind(LL) 0.33 8-13 >624 240		
				Weight: 186 lb	FT = 20%

LUMBER-	BRACING-
TOP CHORD 2x8 SP DSS	TOP CHORD Structural wood sheathing directly applied or 6-0-0 oc purlins.
BOT CHORD 2x10 SP DSS	BOT CHORD Rigid ceiling directly applied or 6-3-5 oc bracing.
WEBS 2x4 SP No.2 *Except*	WEBS 2 Rows at 1/3 pts 6-14
OTHERS 6-7: 2x4 SP SS	JOINTS 1 Brace at Jt(s): 10
OTHERS 2x4 SP No.1	

**REACTIONS.** (size) 2=0-3-8, 14=Mechanical  
 Max Horz 2=380(LC 12)  
 Max Uplift 14=80(LC 12)  
 Max Grav 2=735(LC 20), 14=1149(LC 20)

**FORCES.** (lb) - Max. Comp./Max. Ten. - All forces 250 (lb) or less except when shown.  
 TOP CHORD 2-4=-346/161, 5-6=-159/430  
 WEBS 5-10=-294/80, 7-10=0/682, 6-10=0/677, 6-14=-1149/80

- NOTES-**
- 1) Wind: ASCE 7-10; Vult=130mph (3-second gust) Vasd=103mph; TCDL=6.0psf; BCDL=6.0psf; h=32ft; Cat. II; Exp B; Enclosed; MWFRS (envelope) gable end zone and C-C Exterior(2) -0-6-15 to 2-5-1, Interior(1) 2-5-1 to 17-7-4 zone; cantilever left and right exposed; end vertical left and right exposed; C-C for members and forces & MWFRS for reactions shown; Lumber DOL=1.60 plate grip DOL=1.60
  - 2) All plates are MT20 plates unless otherwise indicated.
  - 3) All plates are 3x6 MT20 unless otherwise indicated.
  - 4) This truss has been designed for a 10.0 psf bottom chord live load nonconcurrent with any other live loads.
  - 5) \* This truss has been designed for a live load of 20.0psf on the bottom chord in all areas where a rectangle 3-6-0 tall by 2-0-0 wide will fit between the bottom chord and any other members, with BCDL = 10.0psf.
  - 6) Ceiling dead load (5.0 psf) on member(s). 4-5, 5-10; Wall dead load (5.0psf) on member(s). 4-8, 7-10
  - 7) Bottom chord live load (40.0 psf) and additional bottom chord dead load (5.0 psf) applied only to room. 7-8
  - 8) Refer to girder(s) for truss to truss connections.
  - 9) Provide mechanical connection (by others) of truss to bearing plate capable of withstanding 100 lb uplift at joint(s) 14.
  - 10) Attic room checked for L/360 deflection.



February 15, 2021

Job MASTER_RT130	Truss AT08	Truss Type ATTIC	Qty 1	Ply 1	MCKEE; NELSON 144818021
---------------------	---------------	---------------------	----------	----------	----------------------------

Builders FirstSource (Apex, NC),

Apex, NC - 27523,

8.240 s Mar 9 2020 MiTek Industries, Inc. Mon Feb 15 14:19:58 2021 Page 1

ID:f0X\_NZYyOMto?npzE4iXPzyeg2c-XjAY6m\_ot\_egegZFovOKNh8gogpPDsMInPC70OzksuF

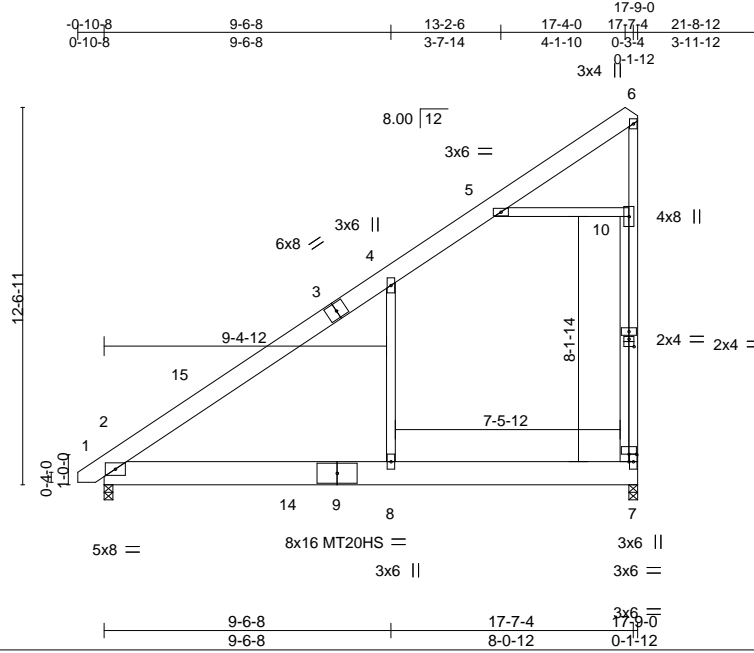

Scale = 1:76.7

Plate Offsets (X,Y)-- [7:0-3-0,0-0-0], [10:0-0-0,4-0-15], [10:0-2-0,3-9-15], [10:0-0-0,4-0-15]

LOADING (psf)	SPACING-	1-7-3	CSI.	DEFL.	in (loc)	l/defl	L/d	PLATES	GRIP
TCLL 20.0	Plate Grip DOL	1.15	TC 0.68	Vert(LL)	-0.38	8-13	>557	MT20	244/190
TCDL 10.0	Lumber DOL	1.15	BC 0.52	Vert(CT)	-0.70	8-13	>303	MT20HS	187/143
BCLL 0.0 *	Rep Stress Incr	YES	WB 0.08	Horz(CT)	0.03	2	n/a		
BCDL 10.0	Code IRC2015/TPI2014		Matrix-MS	Wind(LL)	0.30	8-13	>699		
								Weight: 183 lb	FT = 20%

**LUMBER-**  
 TOP CHORD 2x8 SP DSS  
 BOT CHORD 2x10 SP DSS  
 WEBS 2x4 SP No.2  
 OTHERS 2x4 SP No.2 \*Except\*  
 6-7: 2x4 SP No.1

**BRACING-**  
 TOP CHORD Structural wood sheathing directly applied or 6-0-0 oc purlins.  
 BOT CHORD Rigid ceiling directly applied or 5-5-6 oc bracing.

**REACTIONS.** (size) 2=0-3-8, 7=0-3-8  
 Max Horz 2=371(LC 11)  
 Max Uplift 2=-11(LC 12), 7=-85(LC 12)  
 Max Grav 2=736(LC 21), 7=1087(LC 20)

**FORCES.** (lb) - Max. Comp./Max. Ten. - All forces 250 (lb) or less except when shown.  
 TOP CHORD 2-4=-432/326, 5-6=-102/284, 7-10=-394/115, 6-10=-371/130  
 WEBS 5-10=-341/206, 4-8=-375/261

- NOTES-**
- 1) Wind: ASCE 7-10; Vult=130mph (3-second gust) Vasd=103mph; TCDL=6.0psf; BCDL=6.0psf; h=32ft; Cat. II; Exp B; Enclosed; MWFRS (envelope) gable end zone and C-C Exterior(2) -0-6-15 to 2-5-1, Interior(1) 2-5-1 to 17-7-0 zone; cantilever left and right exposed; end vertical left and right exposed; C-C for members and forces & MWFRS for reactions shown; Lumber DOL=1.60 plate grip DOL=1.60
  - 2) All plates are MT20 plates unless otherwise indicated.
  - 3) This truss has been designed for a 10.0 psf bottom chord live load nonconcurrent with any other live loads.
  - 4) \* This truss has been designed for a live load of 20.0psf on the bottom chord in all areas where a rectangle 3-6-0 tall by 2-0-0 wide will fit between the bottom chord and any other members, with BCDL = 10.0psf.
  - 5) Ceiling dead load (5.0 psf) on member(s). 4-5, 5-10; Wall dead load (5.0psf) on member(s).4-8
  - 6) Bottom chord live load (40.0 psf) and additional bottom chord dead load (5.0 psf) applied only to room. 7-8
  - 7) Provide mechanical connection (by others) of truss to bearing plate capable of withstanding 100 lb uplift at joint(s) 2, 7.
  - 8) Attic room checked for L/360 deflection.



February 15, 2021

**WARNING - Verify design parameters and READ NOTES ON THIS AND INCLUDED MITEK REFERENCE PAGE MII-7473 rev. 5/19/2020 BEFORE USE.**

Design valid for use only with MiTek® connectors. This design is based only upon parameters shown, and is for an individual building component, not a truss system. Before use, the building designer must verify the applicability of design parameters and properly incorporate this design into the overall building design. Bracing indicated is to prevent buckling of individual truss web and/or chord members only. Additional temporary and permanent bracing is always required for stability and to prevent collapse with possible personal injury and property damage. For general guidance regarding the fabrication, storage, delivery, erection and bracing of trusses and truss systems, see

**ANSI/TPI1 Quality Criteria, DSB-89 and BCSI Building Component**

**Safety Information** available from Truss Plate Institute, 2670 Crain Highway, Suite 203 Waldorf, MD 20601



818 Soundside Road  
 Edenton, NC 27932



Job MASTER_RT130	Truss AT09GR	Truss Type ATTIC	Qty 1	Ply 1	MCKEE; NELSON	144818022
---------------------	-----------------	---------------------	----------	----------	---------------	-----------

Builders FirstSource (Apex, NC), Apex, NC - 27523, 8.240 s Mar 9 2020 MiTek Industries, Inc. Mon Feb 15 14:19:59 2021 Page 1

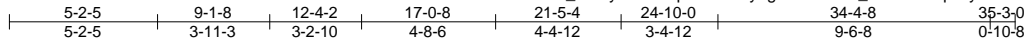

5x6 =

Scale = 1:80.8

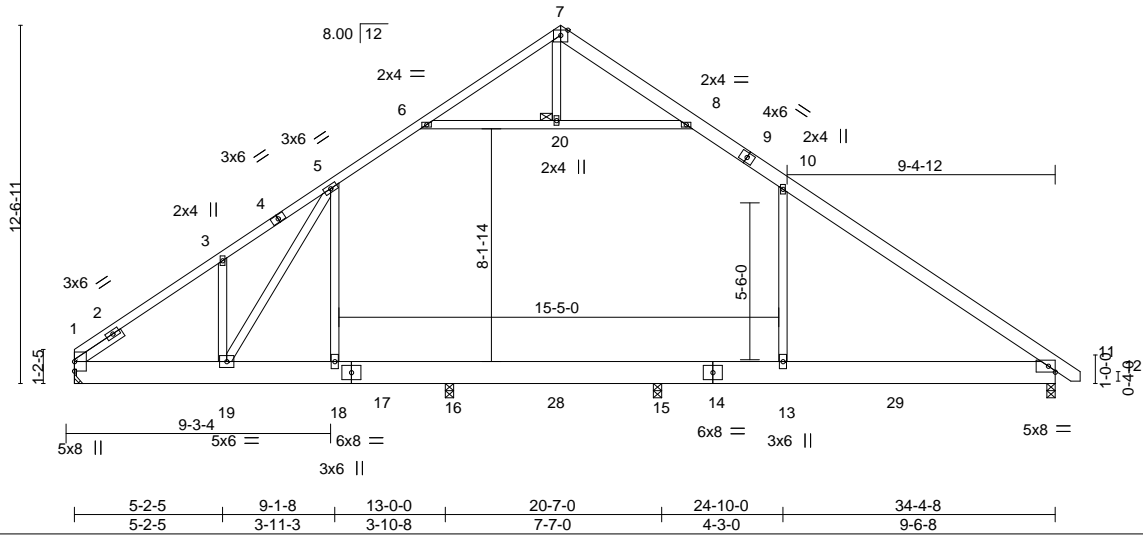

LOADING (psf)	SPACING-	CSI.	DEFL.	in (loc)	l/defl	L/d	PLATES	GRIP
TCLL 20.0	2-0-0	TC 0.48	Vert(LL)	-0.09 13-27	>999	360	MT20	244/190
TCDL 10.0	Plate Grip DOL 1.15	BC 0.45	Vert(CT)	-0.17 13-27	>959	240		
BCLL 0.0 *	Lumber DOL 1.15	WB 0.40	Horz(CT)	0.01 11	n/a	n/a		
BCDL 10.0	Rep Stress Incr NO	Matrix-MS	Wind(LL)	0.11 13-27	>999	240		
	Code IRC2015/TPI2014						Weight: 273 lb	FT = 20%

LUMBER-	BRACING-
TOP CHORD 2x4 SP No.2 *Except* 7-9,9-12: 2x6 SP No.2	TOP CHORD Structural wood sheathing directly applied or 5-2-15 oc purlins.
BOT CHORD 2x10 SP DSS	BOT CHORD Rigid ceiling directly applied or 8-7-14 oc bracing.
WEBS 2x4 SP No.2 *Except* 5-19,7-20,3-19: 2x4 SP No.3	JOINTS 1 Brace at Jt(s): 20
SLIDER Left 2x4 SP No.3 1-11-12	

**REACTIONS.** All bearings 0-3-8 except (jt=length) 1=Mechanical.  
 (lb) - Max Horz 1=301(LC 4)  
 Max Uplift All uplift 100 lb or less at joint(s) 1, 11 except 15=213(LC 9), 16=150(LC 8)  
 Max Grav All reactions 250 lb or less at joint(s) except 1=965(LC 1), 11=990(LC 1), 15=2196(LC 17), 16=1824(LC 16)

**FORCES.** (lb) - Max. Comp./Max. Ten. - All forces 250 (lb) or less except when shown.  
 TOP CHORD 1-3=-1164/60, 3-5=-1175/188, 5-6=-887/158, 6-7=-364/78, 7-8=-374/84, 8-10=-898/210, 10-11=-1012/148  
 BOT CHORD 1-19=-138/1011, 18-19=-12/760, 16-18=-12/760, 15-16=-12/760, 13-15=-12/760, 11-13=-12/760  
 WEBS 6-20=-478/202, 8-20=-481/201, 5-18=-558/230, 10-13=-519/252, 5-19=-249/497, 3-19=-259/184

- NOTES-**
- Unbalanced roof live loads have been considered for this design.
  - Wind: ASCE 7-10; Vult=130mph (3-second gust) Vasd=103mph; TC DL=6.0psf; BCDL=6.0psf; h=32ft; Cat. II; Exp B; Enclosed; MWFRS (envelope) gable end zone; cantilever left and right exposed; end vertical left and right exposed; Lumber DOL=1.60 plate grip DOL=1.60
  - This truss has been designed for a 10.0 psf bottom chord live load nonconcurrent with any other live loads.
  - \* This truss has been designed for a live load of 20.0psf on the bottom chord in all areas where a rectangle 3-6-0 tall by 2-0-0 wide will fit between the bottom chord and any other members, with BCDL = 10.0psf.
  - Ceiling dead load (5.0 psf) on member(s). 5-6, 8-10, 6-20, 8-20; Wall dead load (5.0psf) on member(s). 5-18, 10-13
  - Bottom chord live load (40.0 psf) and additional bottom chord dead load (5.0 psf) applied only to room. 16-18, 15-16, 13-15
  - Refer to girder(s) for truss to truss connections.
  - Provide mechanical connection (by others) of truss to bearing plate capable of withstanding 100 lb uplift at joint(s) 1, 11 except (jt=lb) 15=213, 16=150.
  - Hanger(s) or other connection device(s) shall be provided sufficient to support concentrated load(s) 1406 lb down and 154 lb up at 17-0-8 on bottom chord. The design/selection of such connection device(s) is the responsibility of others.
  - Attic room checked for L/360 deflection.
  - In the LOAD CASE(S) section, loads applied to the face of the truss are noted as front (F) or back (B).

**LOAD CASE(S)** Standard

Continued on page 2



February 15, 2021

**WARNING - Verify design parameters and READ NOTES ON THIS AND INCLUDED MITEK REFERENCE PAGE MII-7473 rev. 5/19/2020 BEFORE USE.**  
 Design valid for use only with MiTek® connectors. This design is based only upon parameters shown, and is for an individual building component, not a truss system. Before use, the building designer must verify the applicability of design parameters and properly incorporate this design into the overall building design. Bracing indicated is to prevent buckling of individual truss web and/or chord members only. Additional temporary and permanent bracing is always required for stability and to prevent collapse with possible personal injury and property damage. For general guidance regarding the fabrication, storage, delivery, erection and bracing of trusses and truss systems, see **ANSI/TPI Quality Criteria, DSB-89 and BCSI Building Component Safety Information** available from Truss Plate Institute, 2670 Crain Highway, Suite 203 Waldorf, MD 20601

**ENGINEERING BY TRESCO**  
 A MiTek Affiliate  
 818 Soundside Road  
 Edenton, NC 27932

Job MASTER_RT130	Truss AT09GR	Truss Type ATTIC	Qty 1	Ply 1	MCKEE; NELSON  Job Reference (optional)	I44818022
---------------------	-----------------	---------------------	----------	----------	---	-----------

Builders FirstSource (Apex, NC), Apex, NC - 27523,

8.240 s Mar 9 2020 MiTek Industries, Inc. Mon Feb 15 14:19:59 2021 Page 2  
ID:f0X\_NZYyOMto?npzE4iXPzyeg2c-?vkwK5\_QeHmXFqYSycvZwuhuh4AgyEZR03ygYrzkusE

**LOAD CASE(S)** Standard

1) Dead + Roof Live (balanced): Lumber Increase=1.15, Plate Increase=1.15

Uniform Loads (plf)

Vert: 18-21=-20, 13-18=-30, 13-25=-20, 1-5=-60, 5-6=-70, 6-7=-60, 7-8=-60, 8-10=-70, 10-12=-60, 6-8=-10

Drag: 5-18=-10, 10-13=-10

Concentrated Loads (lb)

Vert: 28=-800(F)

**WARNING** - Verify design parameters and READ NOTES ON THIS AND INCLUDED MITEK REFERENCE PAGE MII-7473 rev. 5/19/2020 BEFORE USE.

Design valid for use only with MiTek® connectors. This design is based only upon parameters shown, and is for an individual building component, not a truss system. Before use, the building designer must verify the applicability of design parameters and properly incorporate this design into the overall building design. Bracing indicated is to prevent buckling of individual truss web and/or chord members only. Additional temporary and permanent bracing is always required for stability and to prevent collapse with possible personal injury and property damage. For general guidance regarding the fabrication, storage, delivery, erection and bracing of trusses and truss systems, see **ANSI/TPI1 Quality Criteria, DSB-89 and BCSI Building Component Safety Information** available from Truss Plate Institute, 2670 Crain Highway, Suite 203 Waldorf, MD 20601



818 Soundside Road  
Edenton, NC 27932

Job MASTER_RT130	Truss AT10	Truss Type ATTIC	Qty 1	Ply 1	MCKEE; NELSON	144818023
---------------------	---------------	---------------------	----------	----------	---------------	-----------

Builders FirstSource (Apex, NC), Apex, NC - 27523, 8.240 s Mar 9 2020 MiTek Industries, Inc. Mon Feb 15 14:20:00 2021 Page 1

ID:f0X\_NZYyOMto?npzE4iXPzyeg2c-T6iXR?2PbuNtz7eWKQoS6D37UYZhhgbEjhE5HzksuD

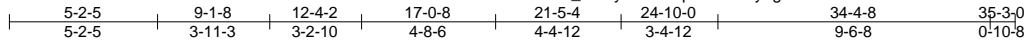

5x6 =

Scale = 1:80.8

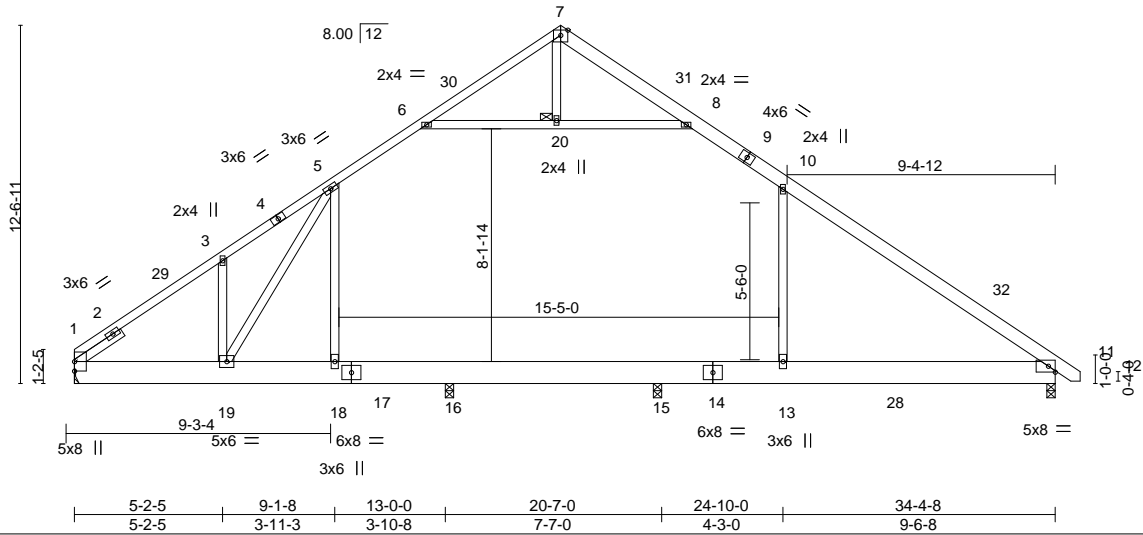

LOADING (psf)	SPACING-	CSI.	DEFL.	in (loc)	l/defl	L/d	PLATES	GRIP
TCLL 20.0	2-0-0	TC 0.50	Vert(LL)	-0.12 13-27	>999	360	MT20	244/190
TCDL 10.0	Plate Grip DOL 1.15	BC 0.35	Vert(CT)	-0.22 13-27	>760	240		
BCLL 0.0 *	Lumber DOL 1.15	WB 0.41	Horz(CT)	0.01 11	n/a	n/a		
BCDL 10.0	Rep Stress Incr NO	Matrix-MS	Wind(LL)	0.12 13-27	>999	240		
	Code IRC2015/TPI2014						Weight: 273 lb	FT = 20%

LUMBER-	BRACING-
TOP CHORD 2x4 SP No.2 *Except* 7-9,9-12: 2x6 SP No.2	TOP CHORD Structural wood sheathing directly applied or 4-11-13 oc purlins.
BOT CHORD 2x10 SP DSS	BOT CHORD Rigid ceiling directly applied or 10-0-0 oc bracing.
WEBS 2x4 SP No.2 *Except* 5-19,7-20,3-19: 2x4 SP No.3	JOINTS 1 Brace at Jt(s): 20
SLIDER Left 2x4 SP No.3 1-11-12	

**REACTIONS.** All bearings 0-3-8 except (jt=length) 1=Mechanical.  
 (lb) - Max Horz 1=301(LC 8)  
 Max Uplift All uplift 100 lb or less at joint(s) 1, 11, 16 except 15=131(LC 13)  
 Max Grav All reactions 250 lb or less at joint(s) except 1=1012(LC 1), 11=1031(LC 1), 15=1441(LC 21), 16=1019(LC 20)

**FORCES.** (lb) - Max. Comp./Max. Ten. - All forces 250 (lb) or less except when shown.  
 TOP CHORD 1-3=-1236/101, 3-5=-1252/212, 5-6=-899/188, 6-7=-356/77, 7-8=-366/82,  
 8-10=-921/214, 10-11=-1076/155  
 BOT CHORD 1-19=-150/1117, 18-19=-17/809, 16-18=-17/809, 15-16=-17/809, 13-15=-17/809,  
 11-13=-17/809  
 WEBS 6-20=-568/209, 8-20=-572/208, 5-18=-570/231, 10-13=-496/248, 5-19=-262/611,  
 3-19=-289/185

- NOTES-**
- 1) Unbalanced roof live loads have been considered for this design.
  - 2) Wind: ASCE 7-10; Vult=130mph (3-second gust) Vasd=103mph; TCCL=6.0psf; BCDL=6.0psf; h=32ft; Cat. II; Exp B; Enclosed; MWFRS (envelope) gable end zone and C-C Exterior(2) 0-3-8 to 3-9-2, Interior(1) 3-9-2 to 17-4-0, Exterior(2) 17-4-0 to 20-9-10, Interior(1) 20-9-10 to 35-4-9 zone; cantilever left and right exposed; end vertical left and right exposed; C-C for members and forces & MWFRS for reactions shown; Lumber DOL=1.60 plate grip DOL=1.60
  - 3) This truss has been designed for a 10.0 psf bottom chord live load nonconcurrent with any other live loads.
  - 4) \* This truss has been designed for a live load of 20.0psf on the bottom chord in all areas where a rectangle 3-6-0 tall by 2-0-0 wide will fit between the bottom chord and any other members, with BCDL = 10.0psf.
  - 5) Ceiling dead load (5.0 psf) on member(s). 5-6, 8-10, 6-20, 8-20; Wall dead load (5.0psf) on member(s).5-18, 10-13
  - 6) Bottom chord live load (40.0 psf) and additional bottom chord dead load (5.0 psf) applied only to room. 16-18, 15-16, 13-15
  - 7) Refer to girder(s) for truss to truss connections.
  - 8) Provide mechanical connection (by others) of truss to bearing plate capable of withstanding 100 lb uplift at joint(s) 1, 11, 16 except (jt=lb) 15=131.
  - 9) Attic room checked for L/360 deflection.



February 15, 2021

Job MASTER_RT130	Truss AT12	Truss Type ATTIC	Qty 1	Ply 1	MCKEE; NELSON	144818024
---------------------	---------------	---------------------	----------	----------	---------------	-----------

Builders FirstSource (Apex, NC), Apex, NC - 27523, 8.240 s Mar 9 2020 MiTek Industries, Inc. Mon Feb 15 14:20:01 2021 Page 1  
 ID:f0X\_NZYyOMto?npzE4iXPzyeg2c-xlsgkn0hAv0EV7iq41x1?Jm94uprQ7ZkTNRndjzksuC

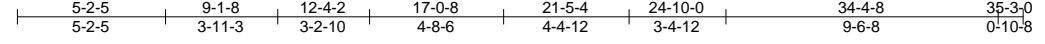

5x6 =

Scale = 1:80.8

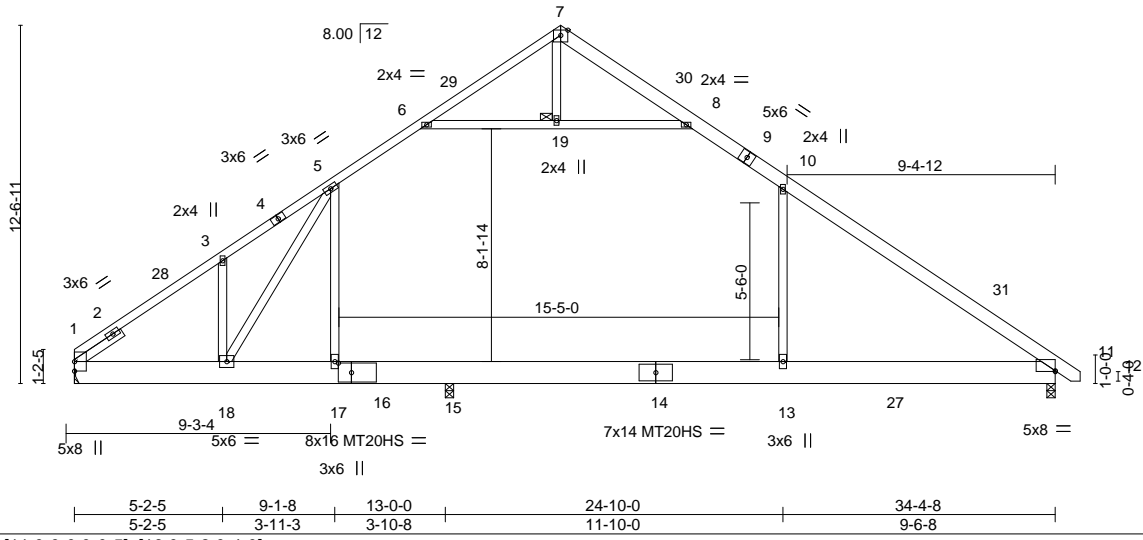

Plate Offsets (X,Y)-- [11:0-0-0,0-0-5], [16:0-5-8,0-4-0]

LOADING (psf)	SPACING-	CSI.	DEFL.	in (loc)	l/defl	L/d	PLATES	GRIP
TCLL 20.0	2-0-0	TC 0.81	Vert(LL)	-0.59	13-15	>432	MT20	244/190
TCDL 10.0	Plate Grip DOL 1.15	BC 0.66	Vert(CT)	-0.94	13-15	>271	MT20HS	187/143
BCLL 0.0 *	Lumber DOL 1.15	WB 0.50	Horz(CT)	-0.04	11	n/a		
BCDL 10.0	Rep Stress Incr NO	Matrix-MS	Wind(LL)	0.34	13	>744		
	Code IRC2015/TPI2014						Weight: 273 lb	FT = 20%

**LUMBER-**  
 TOP CHORD 2x4 SP SS \*Except\*  
 7-9: 2x6 SP No.2, 1-4: 2x4 SP No.2, 9-12: 2x6 SP DSS  
 BOT CHORD 2x10 SP DSS  
 WEBS 2x4 SP No.2 \*Except\*  
 5-18,7-19,3-18: 2x4 SP No.3  
 SLIDER Left 2x4 SP No.3 1-11-12

**BRACING-**  
 TOP CHORD Structural wood sheathing directly applied or 4-5-0 oc purlins.  
 BOT CHORD Rigid ceiling directly applied or 6-3-5 oc bracing.  
 JOINTS 1 Brace at Jt(s): 19

**REACTIONS.** (size) 1=Mechanical, 11=0-3-8, 15=0-3-8  
 Max Horz 1=-301(LC 8)  
 Max Uplift 1=-39(LC 12), 11=-80(LC 13)  
 Max Grav 1=1057(LC 1), 11=1515(LC 21), 15=1593(LC 20)

**FORCES.** (lb) - Max. Comp./Max. Ten. - All forces 250 (lb) or less except when shown.  
 TOP CHORD 1-3=-1263/102, 3-5=-1312/211, 5-6=-1223/201, 6-7=-323/75, 7-8=-310/102,  
 8-10=-1136/185, 10-11=-1515/55  
 BOT CHORD 1-18=-143/1151, 17-18=0/1130, 15-17=0/1130, 13-15=0/1130, 11-13=0/1130  
 WEBS 6-19=-1029/204, 8-19=-1033/203, 5-17=-395/552, 10-13=-196/275, 5-18=-473/358,  
 3-18=-359/164

- NOTES-**
- 1) Unbalanced roof live loads have been considered for this design.
  - 2) Wind: ASCE 7-10; Vult=130mph (3-second gust) Vasd=103mph; TCDL=6.0psf; BCDL=6.0psf; h=32ft; Cat. II; Exp B; Enclosed; MWFRS (envelope) gable end zone and C-C Exterior(2) 0-3-8 to 3-9-2, Interior(1) 3-9-2 to 17-4-0, Exterior(2) 17-4-0 to 20-9-10, Interior(1) 20-9-10 to 35-4-9 zone; cantilever left and right exposed ; end vertical left and right exposed; C-C for members and forces & MWFRS for reactions shown; Lumber DOL=1.60 plate grip DOL=1.60
  - 3) All plates are MT20 plates unless otherwise indicated.
  - 4) This truss has been designed for a 10.0 psf bottom chord live load nonconcurrent with any other live loads.
  - 5) \* This truss has been designed for a live load of 20.0psf on the bottom chord in all areas where a rectangle 3-6-0 tall by 2-0-0 wide will fit between the bottom chord and any other members, with BCDL = 10.0psf.
  - 6) Ceiling dead load (5.0 psf) on member(s). 5-6, 8-10, 6-19, 8-19; Wall dead load (5.0psf) on member(s).5-17, 10-13
  - 7) Bottom chord live load (40.0 psf) and additional bottom chord dead load (5.0 psf) applied only to room. 15-17, 13-15
  - 8) Refer to girder(s) for truss to truss connections.
  - 9) Provide mechanical connection (by others) of truss to bearing plate capable of withstanding 100 lb uplift at joint(s) 1, 11.
  - 10) Attic room checked for L/360 deflection.



February 15, 2021

**WARNING - Verify design parameters and READ NOTES ON THIS AND INCLUDED MITEK REFERENCE PAGE MII-7473 rev. 5/19/2020 BEFORE USE.**  
 Design valid for use only with MiTek® connectors. This design is based only upon parameters shown, and is for an individual building component, not a truss system. Before use, the building designer must verify the applicability of design parameters and properly incorporate this design into the overall building design. Bracing indicated is to prevent buckling of individual truss web and/or chord members only. Additional temporary and permanent bracing is always required for stability and to prevent collapse with possible personal injury and property damage. For general guidance regarding the fabrication, storage, delivery, erection and bracing of trusses and truss systems, see ANSITPI1 Quality Criteria, DSB-89 and BCSI Building Component Safety Information available from Truss Plate Institute, 2670 Crain Highway, Suite 203 Waldorf, MD 20601

**ENGINEERING BY**  
**TRENCO**  
 A MiTek Affiliate  
 818 Soundside Road  
 Edenton, NC 27932

Job MASTER_RT130	Truss AT14G	Truss Type GABLE	Qty 1	Ply 1	MCKEE; NELSON	144818025
---------------------	----------------	---------------------	----------	----------	---------------	-----------

Builders FirstSource (Apex, NC), Apex, NC - 27523, 8.240 s Mar 9 2020 MiTek Industries, Inc. Mon Feb 15 14:20:03 2021 Page 1  
 ID:foX\_NZyOMto?npzE4iXPzyeg2c-th\_R9T2xiWgYkRsDBSzV4krbGhd\_u1x1xgwiuczkksuA

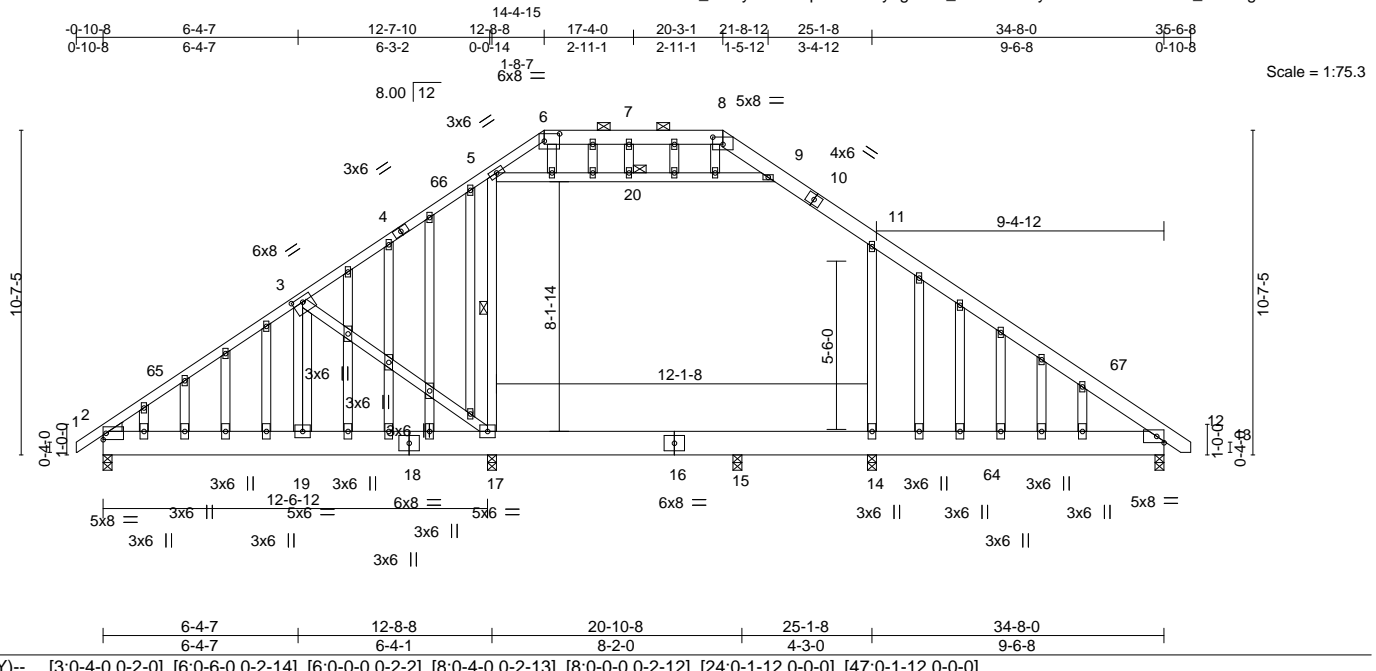

Plate Offsets (X, Y)--	[3:0-4-0,0-2-0], [6:0-6-0,0-2-14], [6:0-0-0,0-2-2], [8:0-4-0,0-2-13], [8:0-0-0,0-2-12], [24:0-1-12,0-0-0], [47:0-1-12,0-0-0]
------------------------	--

LOADING (psf)	SPACING-	2-0-0	CSI.	DEFL.	in (loc)	l/defl	L/d	PLATES	GRIP
TCLL 20.0	Plate Grip DOL	1.15	TC 0.45	Vert(LL)	-0.02 15-17	>999	360	MT20	244/190
TCDL 10.0	Lumber DOL	1.15	BC 0.11	Vert(CT)	-0.03 14-63	>999	240		
BCLL 0.0 *	Rep Stress Incr	YES	WB 0.51	Horz(CT)	0.01 12	n/a	n/a		
BCDL 10.0	Code IRC2015/TPI2014		Matrix-MS	Wind(LL)	0.02 14-63	>999	240		
								Weight: 363 lb	FT = 20%

LUMBER-	BRACING-
TOP CHORD 2x6 SP No.2 *Except* 4-6,1-4: 2x4 SP No.2	TOP CHORD Structural wood sheathing directly applied or 5-9-3 oc purlins, except 2-0-0 oc purlins (6-0-0 max.): 6-8.
BOT CHORD 2x10 SP DSS	BOT CHORD Rigid ceiling directly applied or 10-0-0 oc bracing.
WEBS 2x4 SP No.2 *Except* 3-17,3-19,7-20: 2x4 SP No.3	WEBS 1 Row at midpt 5-17
OTHERS 2x4 SP No.3	JOINTS 1 Brace at Jt(s): 20
WEDGE Left: 2x4 SP No.3	

**REACTIONS.** All bearings 0-3-8.  
 (lb) - Max Horz 2=257(LC 10)  
 Max Uplift All uplift 100 lb or less at joint(s) 2, 17 except 14=248(LC 13)  
 Max Grav All reactions 250 lb or less at joint(s) except 2=814(LC 1), 17=1126(LC 20), 14=1126(LC 21), 12=634(LC 1), 15=719(LC 18)

**FORCES.** (lb) - Max. Comp./Max. Ten. - All forces 250 (lb) or less except when shown.  
 TOP CHORD 2-3=-946/94, 3-5=-596/161, 5-6=-516/143, 8-9=-519/141, 9-11=-627/149, 11-12=-627/99, 6-7=-427/130, 7-8=-428/130  
 BOT CHORD 2-19=-124/704, 17-19=-124/704, 15-17=-61/456, 14-15=-61/456, 12-14=-61/456  
 WEBS 5-17=-372/157, 11-14=-635/250, 3-17=-449/231

- NOTES-**
- Unbalanced roof live loads have been considered for this design.
  - Wind: ASCE 7-10; Vult=130mph (3-second gust) Vasd=103mph; TCDL=6.0psf; BCDL=6.0psf; h=32ft; Cat. II; Exp B; Enclosed; MWFRS (envelope) gable end zone and C-C Exterior(2) 0-10-6 to 2-1-10, Interior(1) 2-1-10 to 14-4-15, Exterior(2) 14-4-15 to 17-2-3, Interior(1) 17-2-3 to 20-3-1, Exterior(2) 20-3-1 to 23-3-1, Interior(1) 23-3-1 to 35-4-9 zone; cantilever left and right exposed; end vertical left and right exposed; C-C for members and forces & MWFRS for reactions shown; Lumber DOL=1.60 plate grip DOL=1.60
  - Truss designed for wind loads in the plane of the truss only. For studs exposed to wind (normal to the face), see Standard Industry Gable End Details as applicable, or consult qualified building designer as per ANSI/TPI 1.
  - Provide adequate drainage to prevent water ponding.
  - All plates are 2x4 MT20 unless otherwise indicated.
  - Gable studs spaced at 1-4-0 oc.
  - This truss has been designed for a 10.0 psf bottom chord live load nonconcurrent with any other live loads.
  - \* This truss has been designed for a live load of 20.0psf on the bottom chord in all areas where a rectangle 3-6-0 tall by 2-0-0 wide will fit between the bottom chord and any other members, with BCDL = 10.0psf.
  - Ceiling dead load (5.0 psf) on member(s). 9-11, 5-20, 9-20; Wall dead load (5.0psf) on member(s).5-17, 11-14
  - Bottom chord live load (40.0 psf) and additional bottom chord dead load (5.0 psf) applied only to room. 15-17, 14-15
  - Provide mechanical connection (by others) of truss to bearing plate capable of withstanding 100 lb uplift at joint(s) 2, 17 except (jt=lb) 14=248.
  - Graphical purlin representation does not depict the size or the orientation of the purlin along the top and/or bottom chord.
  - Attic room checked for L/360 deflection.



February 15, 2021

**WARNING - Verify design parameters and READ NOTES ON THIS AND INCLUDED MITEK REFERENCE PAGE MII-7473 rev. 5/19/2020 BEFORE USE.**  
 Design valid for use only with MiTek® connectors. This design is based only upon parameters shown, and is for an individual building component, not a truss system. Before use, the building designer must verify the applicability of design parameters and properly incorporate this design into the overall building design. Bracing indicated is to prevent buckling of individual truss web and/or chord members only. Additional temporary and permanent bracing is always required for stability and to prevent collapse with possible personal injury and property damage. For general guidance regarding the fabrication, storage, delivery, erection and bracing of trusses and truss systems, see **ANSI/TPI1 Quality Criteria, DSB-89 and BCSI Building Component Safety Information** available from Truss Plate Institute, 2670 Crain Highway, Suite 203 Waldorf, MD 20601

**ENGINEERING BY**  
**TRENCO**  
 A MiTek Affiliate

818 Soundside Road  
 Edenton, NC 27932

Job MASTER_RT130	Truss AT15G	Truss Type GABLE	Qty 1	Ply 1	MCKEE; NELSON	144818026
---------------------	----------------	---------------------	----------	----------	---------------	-----------

Builders FirstSource (Apex, NC), Apex, NC - 27523, 8.240 s Mar 9 2020 MiTek Industries, Inc. Mon Feb 15 14:20:05 2021 Page 1

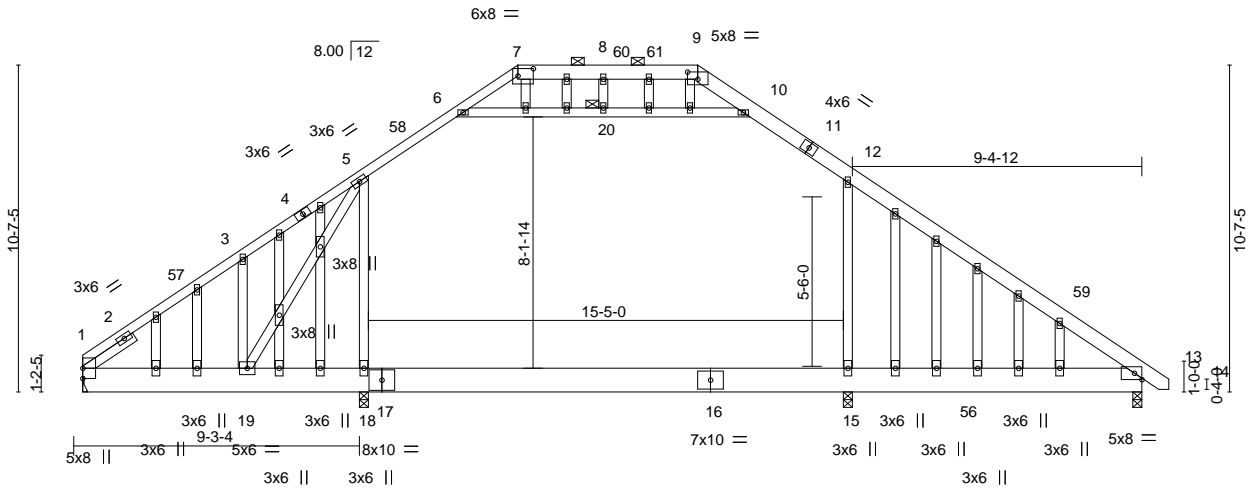
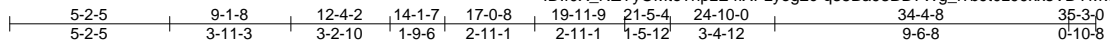

Scale = 1:74.8

Plate Offsets (X, Y)--	[7:0-0-0,0-2-2], [7:0-6-0,0-2-14], [9:0-0-0,0-2-12], [9:0-4-0,0-2-13], [24:0-1-12,0-0-0], [38:0-1-12,0-0-0]
------------------------	---

LOADING (psf)	SPACING-	2-0-0	CSI.	DEFL.	in (loc)	l/defl	L/d	PLATES	GRIP
TCLL 20.0	Plate Grip DOL	1.15	TC 0.44	Vert(LL)	-0.21 15-18	>895	360	MT20	244/190
TCDL 10.0	Lumber DOL	1.15	BC 0.49	Vert(CT)	-0.28 15-18	>680	240		
BCLL 0.0 *	Rep Stress Incr	NO	WB 0.53	Horz(CT)	0.01 13	n/a	n/a		
BCDL 10.0	Code IRC2015/TPI2014		Matrix-MS	Wind(LL)	0.02 15-55	>999	240	Weight: 322 lb	FT = 20%

LUMBER-	BRACING-
TOP CHORD 2x6 SP No.2 *Except* 4-7,1-4: 2x4 SP No.2	TOP CHORD Structural wood sheathing directly applied or 6-0-0 oc purlins, except 2-0-0 oc purlins (6-0-0 max.): 7-9.
BOT CHORD 2x10 SP DSS	BOT CHORD Rigid ceiling directly applied or 9-8-12 oc bracing.
WEBS 2x4 SP No.2 *Except* 5-19,8-20,3-19: 2x4 SP No.3	JOINTS 1 Brace at Jt(s): 20
OTHERS 2x4 SP No.3	
SLIDER Left 2x4 SP No.3 1-11-12	

**REACTIONS.** All bearings 0-3-8 except (jt=length) 1=Mechanical.  
 (lb) - Max Horz 1=253(LC 8)  
 Max Uplift All uplift 100 lb or less at joint(s) 1, 18, 13 except 15=108(LC 13)  
 Max Grav All reactions 250 lb or less at joint(s) except 1=698(LC 1), 18=1532(LC 20), 15=1662(LC 21), 13=732(LC 1)

**FORCES.** (lb) - Max. Comp./Max. Ten. - All forces 250 (lb) or less except when shown.  
 TOP CHORD 1-3=-686/121, 3-5=-743/227, 5-6=-765/179, 6-7=-553/150, 9-10=-563/153,  
 10-12=-778/197, 12-13=-831/185, 7-8=-459/143, 8-9=-460/142  
 BOT CHORD 1-19=-202/571, 18-19=-131/605, 15-18=-131/605, 13-15=-131/605  
 WEBS 5-18=-445/266, 12-15=-588/269, 5-19=-495/156, 3-19=-258/184

- NOTES-**
- Unbalanced roof live loads have been considered for this design.
  - Wind: ASCE 7-10; Vult=130mph (3-second gust) Vasd=103mph; TCDL=6.0psf; BCDL=6.0psf; h=32ft; Cat. II; Exp B; Enclosed; MWFRS (envelope) gable end zone and C-C Exterior(2) 0-3-8 to 3-9-2, Interior(1) 3-9-2 to 14-4-15, Exterior(2) 14-4-15 to 17-10-9, Interior(1) 17-10-9 to 20-3-1, Exterior(2) 20-3-1 to 23-8-10, Interior(1) 23-8-10 to 35-4-9 zone; cantilever left and right exposed; end vertical left and right exposed; C-C for members and forces & MWFRS for reactions shown; Lumber DOL=1.60 plate grip DOL=1.60
  - Truss designed for wind loads in the plane of the truss only. For studs exposed to wind (normal to the face), see Standard Industry Gable End Details as applicable, or consult qualified building designer as per ANSI/TPI 1.
  - Provide adequate drainage to prevent water ponding.
  - All plates are 2x4 MT20 unless otherwise indicated.
  - Gable studs spaced at 1-4-0 oc.
  - This truss has been designed for a 10.0 psf bottom chord live load nonconcurrent with any other live loads.
  - \* This truss has been designed for a live load of 20.0psf on the bottom chord in all areas where a rectangle 3-6-0 tall by 2-0-0 wide will fit between the bottom chord and any other members, with BCDL = 10.0psf.
  - Ceiling dead load (5.0 psf) on member(s). 5-6, 10-12, 6-20, 10-20; Wall dead load (5.0psf) on member(s).5-18, 12-15
  - Bottom chord live load (40.0 psf) and additional bottom chord dead load (5.0 psf) applied only to room. 15-18
  - Refer to girder(s) for truss to truss connections.
  - Provide mechanical connection (by others) of truss to bearing plate capable of withstanding 100 lb uplift at joint(s) 1, 18, 13 except (jt=lb) 15=108.
  - Graphical purlin representation does not depict the size or the orientation of the purlin along the top and/or bottom chord.
  - Attic room checked for L/360 deflection.



Job MASTER_RT130	Truss B02G	Truss Type GABLE	Qty 1	Ply 1	MCKEE; NELSON	I44818027
---------------------	---------------	---------------------	----------	----------	---------------	-----------

Builders FirstSource, Apex, NC 27523

8.240 s Mar 9 2020 MiTek Industries, Inc. Mon Feb 15 14:28:07 2021 Page 1  
 ID:f0X\_NZYyOMto?npzE4iXPzyeg2c-JkteSX7Ni4FuGeFrTtVbnYuLLopkly8GE\_9VgYzksmc

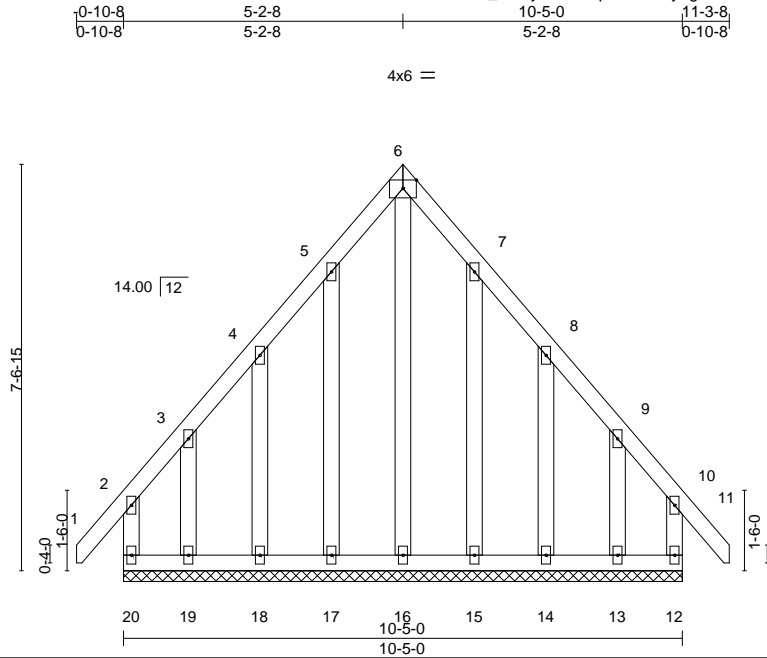

4x6 =

Scale = 1:42.9

Plate Offsets (X,Y)-- [6:Edge,0-1-14]

LOADING (psf)	SPACING-	2-0-0	CSI.	DEFL.	in	(loc)	l/defl	L/d	PLATES	GRIP
TCLL 20.0	Plate Grip DOL	1.15	TC 0.24	Vert(LL)	-0.00	11	n/r	120	MT20	244/190
TCDL 10.0	Lumber DOL	1.15	BC 0.14	Vert(CT)	-0.00	11	n/r	120		
BCLL 0.0 *	Rep Stress Incr	NO	WB 0.42	Horz(CT)	-0.00	12	n/a	n/a		
BCDL 10.0	Code IRC2015/TPI2014		Matrix-R						Weight: 92 lb	FT = 20%

**LUMBER-**  
 TOP CHORD 2x4 SP No.2  
 BOT CHORD 2x4 SP No.2  
 WEBS 2x4 SP No.3  
 OTHERS 2x4 SP No.3

**BRACING-**  
 TOP CHORD Structural wood sheathing directly applied or 6-0-0 oc purlins, except end verticals.  
 BOT CHORD Rigid ceiling directly applied or 6-0-0 oc bracing.

**REACTIONS.** All bearings 10-5-0.  
 (lb) - Max Horz 20=233(LC 11)  
 Max Uplift All uplift 100 lb or less at joint(s) 17, 18, 15, 14 except 20=209(LC 8), 12=193(LC 9), 19=209(LC 9), 13=199(LC 8)  
 Max Grav All reactions 250 lb or less at joint(s) 12, 17, 18, 15, 14 except 20=250(LC 20), 16=311(LC 13), 19=263(LC 10), 13=252(LC 11)

**FORCES.** (lb) - Max. Comp./Max. Ten. - All forces 250 (lb) or less except when shown.  
 TOP CHORD 4-5=172/263, 5-6=229/333, 6-7=229/333, 7-8=172/263  
 WEBS 6-16=-429/249

- NOTES-**
- 1) Unbalanced roof live loads have been considered for this design.
  - 2) Wind: ASCE 7-10; Vult=130mph (3-second gust) Vasd=103mph; TCDL=6.0psf; BCDL=6.0psf; h=32ft; Cat. II; Exp B; Enclosed; MWFRS (envelope) gable end zone and C-C Corner(3) -0-9-15 to 2-2-1, Exterior(2) 2-2-1 to 5-2-8, Corner(3) 5-2-8 to 8-2-8, Exterior(2) 8-2-8 to 11-2-15 zone; cantilever left and right exposed ; end vertical left and right exposed;C-C for members and forces & MWFRS for reactions shown; Lumber DOL=1.60 plate grip DOL=1.60
  - 3) Truss designed for wind loads in the plane of the truss only. For studs exposed to wind (normal to the face), see Standard Industry Gable End Details as applicable, or consult qualified building designer as per ANSI/TPI 1.
  - 4) All plates are 2x4 MT20 unless otherwise indicated.
  - 5) Gable requires continuous bottom chord bearing.
  - 6) Truss to be fully sheathed from one face or securely braced against lateral movement (i.e. diagonal web).
  - 7) Gable studs spaced at 1-4-0 oc.
  - 8) This truss has been designed for a 10.0 psf bottom chord live load nonconcurrent with any other live loads.
  - 9) \* This truss has been designed for a live load of 20.0psf on the bottom chord in all areas where a rectangle 3-6-0 tall by 2-0-0 wide will fit between the bottom chord and any other members.
  - 10) All bearings are assumed to be User Defined crushing capacity of 565 psi.
  - 11) Provide mechanical connection (by others) of truss to bearing plate capable of withstanding 100 lb uplift at joint(s) 17, 18, 15, 14 except (jt=lb) 20=209, 12=193, 19=209, 13=199.



February 15, 2021

**WARNING - Verify design parameters and READ NOTES ON THIS AND INCLUDED MITEK REFERENCE PAGE MII-7473 rev. 5/19/2020 BEFORE USE.**  
 Design valid for use only with MiTek® connectors. This design is based only upon parameters shown, and is for an individual building component, not a truss system. Before use, the building designer must verify the applicability of design parameters and properly incorporate this design into the overall building design. Bracing indicated is to prevent buckling of individual truss web and/or chord members only. Additional temporary and permanent bracing is always required for stability and to prevent collapse with possible personal injury and property damage. For general guidance regarding the fabrication, storage, delivery, erection and bracing of trusses and truss systems, see **ANSI/TPI1 Quality Criteria, DSB-89 and BCSI Building Component Safety Information** available from Truss Plate Institute, 2670 Crain Highway, Suite 203 Waldorf, MD 20601



818 Soundside Road  
 Edenton, NC 27932

Job MASTER_RT130	Truss D07G	Truss Type GABLE	Qty 1	Ply 1	MCKEE; NELSON	144818028
---------------------	---------------	---------------------	----------	----------	---------------	-----------

Builders FirstSource (Apex, NC), Apex, NC - 27523,

8.240 s Mar 9 2020 MiTek Industries, Inc. Mon Feb 15 14:20:07 2021 Page 1

ID:f0X\_NZyOMto?npzE4iXPzyeg2c-mSDx?r5RllmOD29\_Ql2REa0AYluPqUdrIu5rNzksu6

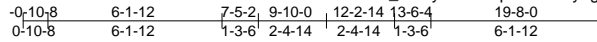

4x6 =

Scale = 1:81.3

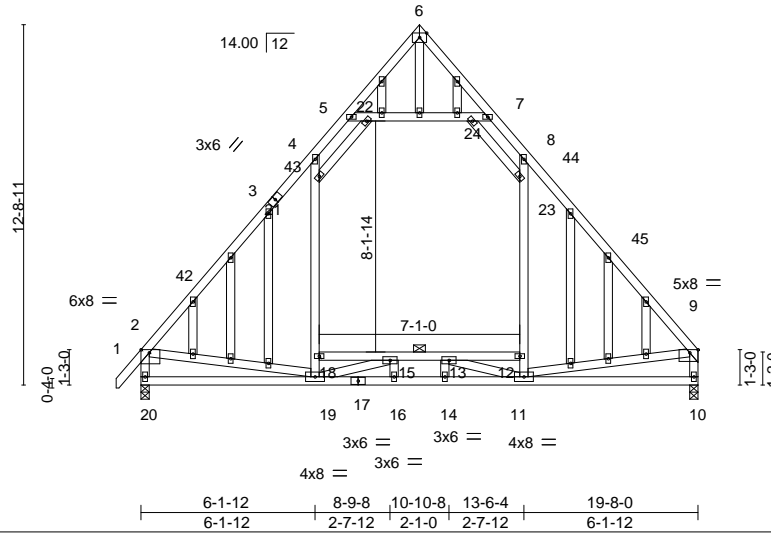

Plate Offsets (X,Y)--	[2:Edge,0-1-5], [6:Edge,0-1-14], [9:Edge,0-1-5]
-----------------------	---

LOADING (psf)	SPACING-	2-0-0	CSI.	DEFL.	in (loc)	l/defl	L/d	PLATES	GRIP
TCLL 20.0	Plate Grip DOL	1.15	TC 0.88	Vert(LL)	-0.12 12-13	>999	360	MT20	244/190
TCDL 10.0	Lumber DOL	1.15	BC 0.52	Vert(CT)	-0.22 12-13	>999	240		
BCLL 0.0 *	Rep Stress Incr	YES	WB 0.47	Horz(CT)	0.02 10	n/a	n/a		
BCDL 10.0	Code IRC2015/TPI2014		Matrix-MS	Wind(LL)	0.16 12	>999	240		
								Weight: 197 lb	FT = 20%

LUMBER-	BRACING-
TOP CHORD 2x4 SP No.1 *Except* 1-3: 2x4 SP No.2	TOP CHORD Structural wood sheathing directly applied or 2-2-0 oc purlins, except end verticals.
BOT CHORD 2x4 SP No.2	BOT CHORD Rigid ceiling directly applied or 10-0-0 oc bracing, Except:
WEBS 2x4 SP No.2 *Except* 13-14,15-16,15-19,11-13,2-19,9-11: 2x4 SP No.3	8-10-3 oc bracing: 19-20. 6-0-0 oc bracing: 12-18
OTHERS 2x4 SP No.3	

**REACTIONS.** (size) 20=0-3-8, 10=0-3-8  
 Max Horz 20=355(LC 9)  
 Max Grav 20=1203(LC 21), 10=1164(LC 20)

**FORCES.** (lb) - Max. Comp./Max. Ten. - All forces 250 (lb) or less except when shown.  
 TOP CHORD 2-4=-1258/0, 4-5=-780/191, 7-8=-800/202, 8-9=-1251/0, 2-20=-1147/34, 9-10=-1109/0  
 BOT CHORD 19-20=-422/613, 16-19=0/1557, 14-16=0/1557, 11-14=0/1557, 10-11=-144/276,  
 15-18=-286/157, 13-15=-913/0, 12-13=-299/160  
 WEBS 5-22=-961/240, 22-24=-865/208, 7-24=-976/245, 18-19=0/365, 18-21=0/538,  
 4-21=-65/634, 11-12=0/355, 12-23=0/527, 8-23=-74/609, 15-19=-841/66, 11-13=-818/49,  
 21-22=-273/272, 23-24=-275/283, 2-19=-37/607, 9-11=0/618

- NOTES-**
- 1) Unbalanced roof live loads have been considered for this design.
  - 2) Wind: ASCE 7-10; Vult=130mph (3-second gust) Vasd=103mph; TCDL=6.0psf; BCDL=6.0psf; h=32ft; Cat. II; Exp B; Enclosed; MWFRS (envelope) gable end zone and C-C Exterior(2) -0-9-15 to 2-2-1, Interior(1) 2-2-1 to 9-10-0, Exterior(2) 9-10-0 to 14-0-15, Interior(1) 14-0-15 to 19-6-4 zone; cantilever left and right exposed ; end vertical left and right exposed; C-C for members and forces & MWFRS for reactions shown; Lumber DOL=1.60 plate grip DOL=1.60
  - 3) Truss designed for wind loads in the plane of the truss only. For studs exposed to wind (normal to the face), see Standard Industry Gable End Details as applicable, or consult qualified building designer as per ANSI/TPI 1.
  - 4) All plates are 2x4 MT20 unless otherwise indicated.
  - 5) Gable studs spaced at 1-4-0 oc.
  - 6) This truss has been designed for a 10.0 psf bottom chord live load nonconcurrent with any other live loads.
  - 7) \* This truss has been designed for a live load of 20.0psf on the bottom chord in all areas where a rectangle 3-6-0 tall by 2-0-0 wide will fit between the bottom chord and any other members.
  - 8) Ceiling dead load (5.0 psf) on member(s). 4-5, 7-8, 5-22, 22-24, 7-24; Wall dead load (5.0psf) on member(s).18-21, 4-21, 12-23, 8-23
  - 9) Bottom chord live load (40.0 psf) and additional bottom chord dead load (5.0 psf) applied only to room. 15-18, 13-15, 12-13
  - 10) See Standard Industry Piggyback Truss Connection Detail for Connection to base truss as applicable, or consult qualified building designer.
  - 11) Attic room checked for L/360 deflection.



February 15, 2021



Job MASTER_RT130	Truss D08	Truss Type ATTIC	Qty 1	Ply 1	MCKEE; NELSON	144818029
---------------------	--------------	---------------------	----------	----------	---------------	-----------

Builders FirstSource (Apex, NC), Apex, NC - 27523, 8.240 s Mar 9 2020 MiTek Industries, Inc. Mon Feb 15 14:20:08 2021 Page 1

ID:f0X\_NZYyOMto?npzE4iXPzyeg2c-EenKCA54W2uFrCkA\_?ZgnoYLIIEeZljm4ydfNpzkusu5

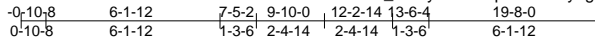

3x6 =

Scale = 1:81.3

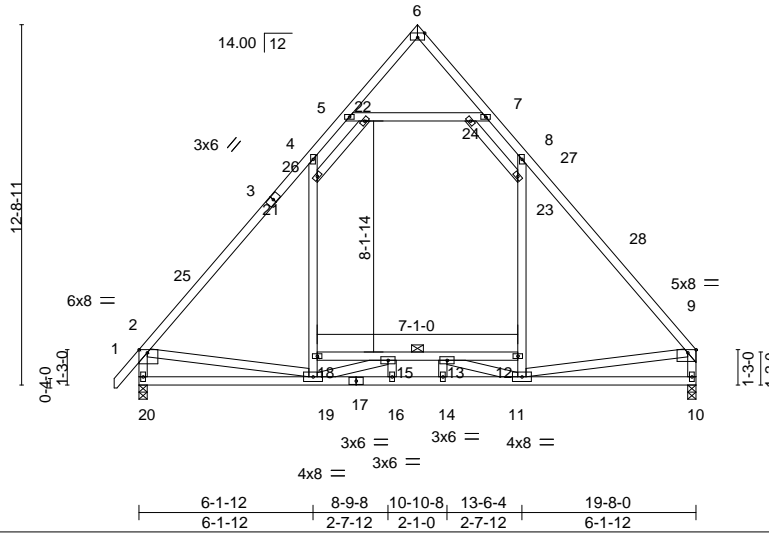

Plate Offsets (X, Y)--	[2:Edge,0-1-5], [6:Edge,0-1-14], [9:Edge,0-1-5]
------------------------	---

LOADING (psf)	SPACING-	2-0-0	CSI.	DEFL.	in (loc)	l/defl	L/d	PLATES	GRIP
TCLL 20.0	Plate Grip DOL	1.15	TC 0.88	Vert(LL)	-0.12	12-13	>999	MT20	244/190
TCDL 10.0	Lumber DOL	1.15	BC 0.52	Vert(CT)	-0.22	12-13	>999		
BCLL 0.0 *	Rep Stress Incr	YES	WB 0.47	Horz(CT)	0.02	10	n/a		
BCDL 10.0	Code IRC2015/TP12014		Matrix-MS	Wind(LL)	0.16	12	>999		
								Weight: 156 lb	FT = 20%

LUMBER-	BRACING-
TOP CHORD 2x4 SP No.1 *Except* 1-3: 2x4 SP No.2	TOP CHORD Structural wood sheathing directly applied or 2-2-0 oc purlins, except end verticals.
BOT CHORD 2x4 SP No.2	BOT CHORD Rigid ceiling directly applied or 10-0-0 oc bracing, Except:
WEBS 2x4 SP No.2 *Except* 13-14,15-16,15-19,11-13,2-19,9-11: 2x4 SP No.3	8-10-3 oc bracing: 19-20. 6-0-0 oc bracing: 12-18

<b>REACTIONS.</b>	(size) 20=0-3-8, 10=0-3-8 Max Horz 20=355(LC 9) Max Grav 20=1203(LC 21), 10=1164(LC 20)
-------------------	---

<b>FORCES.</b>	(lb) - Max. Comp./Max. Ten. - All forces 250 (lb) or less except when shown.
TOP CHORD	2-4=-1258/0, 4-5=-780/191, 7-8=-800/202, 8-9=-1251/0, 2-20=-1147/34, 9-10=-1109/0
BOT CHORD	19-20=-422/613, 16-19=0/1557, 14-16=0/1557, 11-14=0/1557, 10-11=-144/276, 15-18=-286/157, 13-15=-913/0, 12-13=-299/160
WEBS	5-22=-961/240, 22-24=-865/208, 7-24=-976/245, 18-19=0/365, 18-21=0/538, 4-21=-65/634, 11-12=0/355, 12-23=0/527, 8-23=-74/609, 15-19=-841/66, 11-13=-818/49, 21-22=-273/272, 23-24=-275/283, 2-19=-37/607, 9-11=0/618

- NOTES-**
- Unbalanced roof live loads have been considered for this design.
  - Wind: ASCE 7-10; Vult=130mph (3-second gust) Vasd=103mph; TCDL=6.0psf; BCDL=6.0psf; h=32ft; Cat. II; Exp B; Enclosed; MWFRS (envelope) gable end zone and C-C Exterior(2) -0-9-15 to 2-2-1, Interior(1) 2-2-1 to 9-10-0, Exterior(2) 9-10-0 to 14-0-15, Interior(1) 14-0-15 to 19-6-4 zone; cantilever left and right exposed ; end vertical left and right exposed; C-C for members and forces & MWFRS for reactions shown; Lumber DOL=1.60 plate grip DOL=1.60
  - All plates are 2x4 MT20 unless otherwise indicated.
  - This truss has been designed for a 10.0 psf bottom chord live load nonconcurrent with any other live loads.
  - \* This truss has been designed for a live load of 20.0psf on the bottom chord in all areas where a rectangle 3-6-0 tall by 2-0-0 wide will fit between the bottom chord and any other members.
  - Ceiling dead load (5.0 psf) on member(s). 4-5, 7-8, 5-22, 22-24, 7-24; Wall dead load (5.0psf) on member(s).18-21, 4-21, 12-23, 8-23
  - Bottom chord live load (40.0 psf) and additional bottom chord dead load (5.0 psf) applied only to room. 15-18, 13-15, 12-13
  - See Standard Industry Piggyback Truss Connection Detail for Connection to base truss as applicable, or consult qualified building designer.
  - Attic room checked for L/360 deflection.



February 15, 2021

<p><b>WARNING - Verify design parameters and READ NOTES ON THIS AND INCLUDED MITEK REFERENCE PAGE MII-7473 rev. 5/19/2020 BEFORE USE.</b></p> <p>Design valid for use only with MiTek® connectors. This design is based only upon parameters shown, and is for an individual building component, not a truss system. Before use, the building designer must verify the applicability of design parameters and properly incorporate this design into the overall building design. Bracing indicated is to prevent buckling of individual truss web and/or chord members only. Additional temporary and permanent bracing is always required for stability and to prevent collapse with possible personal injury and property damage. For general guidance regarding the fabrication, storage, delivery, erection and bracing of trusses and truss systems, see <b>ANSI/TPI1 Quality Criteria, DSB-89 and BCSI Building Component Safety Information</b> available from Truss Plate Institute, 2670 Crain Highway, Suite 203 Waldorf, MD 20601</p>	<p>ENGINEERING BY</p> <p><b>TRENCO</b></p> <p>A MiTek Affiliate</p> <p>818 Soundside Road Edenton, NC 27932</p>
--	---

Job MASTER_RT130	Truss D09GR	Truss Type ATTIC	Qty 1	Ply 2	MCKEE; NELSON	144818030
---------------------	----------------	---------------------	----------	----------	---------------	-----------

Builders FirstSource (Apex, NC), Apex, NC - 27523, 8.240 s Mar 9 2020 MiTek Industries, Inc. Mon Feb 15 14:20:10 2021 Page 1

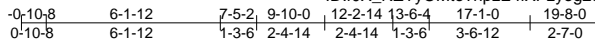

3x6 =

Scale = 1:81.3

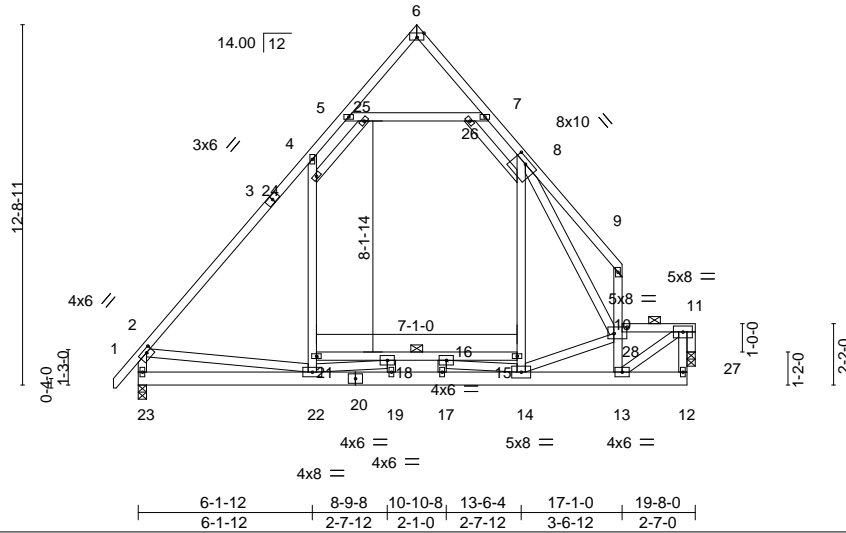

Plate Offsets (X, Y)--	[2:0-2-8,0-1-8], [6:Edge,0-1-14], [8:0-5-0,0-2-0], [10:0-5-8,0-2-12]
------------------------	--

LOADING (psf)	SPACING-	CSI.	DEFL.	PLATES	GRIP
TCLL 20.0	2-0-0	TC 0.92	in (loc) l/defl L/d	MT20	244/190
TCDL 10.0	Plate Grip DOL 1.15	BC 0.62	Vert(LL) -0.14 14 >999 360		
BCLL 0.0 *	Lumber DOL 1.15	WB 0.76	Vert(CT) -0.24 14 >983 240		
BCDL 10.0	Rep Stress Incr NO	Matrix-MS	Horz(CT) -0.02 27 n/a n/a		
	Code IRC2015/TPI2014		Wind(LL) 0.07 15 >999 240	Weight: 372 lb	FT = 20%

LUMBER-	BRACING-
TOP CHORD 2x4 SP No.2	TOP CHORD Structural wood sheathing directly applied or 6-0-0 oc purlins, except end verticals, and 2-0-0 oc purlins (5-4-1 max.): 10-11.
BOT CHORD 2x6 SP No.2 *Except* 15-21,11-27: 2x4 SP No.2	BOT CHORD Rigid ceiling directly applied or 10-0-0 oc bracing. Except: 6-0-0 oc bracing: 15-21
WEBS 2x4 SP No.3 *Except* 5-7,4-22,8-14,24-25,8-26,9-13: 2x4 SP No.2	

REACTIONS.
(size) 23=0-3-8, 27=0-3-8 Max Horz 23=336(LC 5) Max Grav 23=1335(LC 17), 27=2487(LC 16)

FORCES.
(lb) - Max. Comp./Max. Ten. - All forces 250 (lb) or less except when shown.
TOP CHORD 2-4=-1484/0, 4-5=-764/148, 8-9=-256/68, 2-23=-1343/0, 10-11=-3545/0
BOT CHORD 22-23=-525/603, 19-22=0/1866, 17-19=0/1866, 14-17=0/1866, 13-14=0/3291, 16-18=-1059/0, 11-27=-2487/0
WEBS 5-25=-1052/161, 25-26=-997/70, 7-26=-509/106, 21-22=0/541, 21-24=0/702, 4-24=-26/830, 14-15=-6/1246, 8-15=0/1443, 18-22=-1264/0, 14-16=-958/0, 8-26=-835/88, 2-22=-36/777, 10-14=-2642/0, 10-13=-2316/38, 9-10=-309/59, 8-10=-1798/0, 11-13=0/3894

- NOTES-**
- 2-ply truss to be connected together with 10d (0.131"x3") nails as follows:  
Top chords connected as follows: 2x4 - 1 row at 0-2-0 oc.  
Bottom chords connected as follows: 2x6 - 2 rows staggered at 0-9-0 oc, 2x4 - 1 row at 0-9-0 oc.  
Webs connected as follows: 2x4 - 1 row at 0-9-0 oc.
  - All loads are considered equally applied to all plies, except if noted as front (F) or back (B) face in the LOAD CASE(S) section. Ply to ply connections have been provided to distribute only loads noted as (F) or (B), unless otherwise indicated.
  - Unbalanced roof live loads have been considered for this design.
  - Wind: ASCE 7-10; Vult=130mph (3-second gust) Vasd=103mph; TCDL=6.0psf; BCDL=6.0psf; h=32ft; Cat. II; Exp B; Enclosed; MWFRS (envelope) gable end zone; cantilever left and right exposed; end vertical left and right exposed; Lumber DOL=1.60 plate grip DOL=1.60
  - Provide adequate drainage to prevent water ponding.
  - All plates are 2x4 MT20 unless otherwise indicated.
  - This truss has been designed for a 10.0 psf bottom chord live load nonconcurrent with any other live loads.
  - \* This truss has been designed for a live load of 20.0psf on the bottom chord in all areas where a rectangle 3-6-0 tall by 2-0-0 wide will fit between the bottom chord and any other members.
  - Ceiling dead load (5.0 psf) on member(s). 4-5, 7-8, 5-25, 25-26, 7-26; Wall dead load (5.0psf) on member(s).21-24, 4-24, 8-15
  - Bottom chord live load (40.0 psf) and additional bottom chord dead load (5.0 psf) applied only to room. 18-21, 16-18, 15-16
  - Bearing at joint(s) 27 considers parallel to grain value using ANSI/TPI 1 angle to grain formula. Building designer should verify capacity of bearing surface.
  - N/A



February 15, 2021

Continued on page 2

**WARNING - Verify design parameters and READ NOTES ON THIS AND INCLUDED MITEK REFERENCE PAGE MII-7473 rev. 5/19/2020 BEFORE USE.**

Design valid for use only with MiTek® connectors. This design is based only upon parameters shown, and is for an individual building component, not a truss system. Before use, the building designer must verify the applicability of design parameters and properly incorporate this design into the overall building design. Bracing indicated is to prevent buckling of individual truss web and/or chord members only. Additional temporary and permanent bracing is always required for stability and to prevent collapse with possible personal injury and property damage. For general guidance regarding the fabrication, storage, delivery, erection and bracing of trusses and truss systems, see **ANSI/TPI Quality Criteria, DSB-89 and BCSI Building Component Safety Information** available from Truss Plate Institute, 2670 Crain Highway, Suite 203 Waldorf, MD 20601

**ENGINEERING BY**  
**TRENCO**  
A MiTek Affiliate

818 Soundside Road  
Edenton, NC 27932

Job	Truss	Truss Type	Qty	Ply	MCKEE; NELSON	144818030
MASTER_RT130	D09GR	ATTIC	1	2	Job Reference (optional)	

Builders FirstSource (Apex, NC), Apex, NC - 27523,

8.240 s Mar 9 2020 MiTek Industries, Inc. Mon Feb 15 14:20:10 2021 Page 2  
ID:f0X\_NZYyOMto?npzE4iXPzyeg2c-A1v4ds7K2g8z4WuZ5Qc8sDef1Wua18m3YG6mRizksu3

**NOTES-**

- 13) See Standard Industry Piggyback Truss Connection Detail for Connection to base truss as applicable, or consult qualified building designer.
- 14) Graphical purlin representation does not depict the size or the orientation of the purlin along the top and/or bottom chord.
- 15) Hanger(s) or other connection device(s) shall be provided sufficient to support concentrated load(s) 1317 lb down and 134 lb up at 17-5-0 on top chord. The design/selection of such connection device(s) is the responsibility of others.
- 16) Attic room checked for L/360 deflection.

**LOAD CASE(S)** Standard

1) Dead + Roof Live (balanced): Lumber Increase=1.15, Plate Increase=1.15

Uniform Loads (plf)

Vert: 12-23=-20, 1-2=-60, 2-4=-60, 4-5=-70, 5-6=-60, 6-7=-60, 7-8=-70, 8-9=-60, 5-7=-10, 15-21=-30, 10-28=-60, 11-28=-80(F=-20)

Drag: 4-21=-10, 8-15=-10

Concentrated Loads (lb)

Vert: 28=-700(F)

2) Dead + 0.75 Roof Live (balanced) + 0.75 Uninhab. Attic Storage + 0.75 Attic Floor: Lumber Increase=1.15, Plate Increase=1.15

Uniform Loads (plf)

Vert: 12-23=-20, 1-2=-50, 2-4=-50, 4-5=-60, 5-6=-50, 6-7=-50, 7-8=-60, 8-9=-50, 5-7=-10, 15-21=-90, 10-28=-50, 11-28=-130(F=-80)

Drag: 4-21=-10, 8-15=-10

Concentrated Loads (lb)

Vert: 28=-1138(F)

3) Dead + Uninhabitable Attic Without Storage: Lumber Increase=1.25, Plate Increase=1.25

Uniform Loads (plf)

Vert: 12-23=-40, 1-2=-20, 2-4=-20, 4-5=-30, 5-6=-20, 6-7=-20, 7-8=-30, 8-9=-20, 5-7=-10, 15-21=-30, 10-28=-20, 11-28=-120(F=-100)

Drag: 4-21=-10, 8-15=-10

Concentrated Loads (lb)

Vert: 28=-525(F)

4) Dead + 0.6 MWFRS Wind (Pos. Internal) Left: Lumber Increase=1.60, Plate Increase=1.60

Uniform Loads (plf)

Vert: 12-23=-12, 1-2=-3, 2-4=-16, 4-5=-22, 5-6=-16, 6-7=10, 7-8=4, 8-9=10, 5-7=-6, 15-21=-18, 10-28=10, 11-28=-10(F=-20)

Horz: 1-2=-9, 2-6=4, 6-9=22, 2-23=16, 10-11=-22

Drag: 4-21=-10, 8-15=-10

Concentrated Loads (lb)

Vert: 28=-14(F)

5) Dead + 0.6 MWFRS Wind (Pos. Internal) Right: Lumber Increase=1.60, Plate Increase=1.60

Uniform Loads (plf)

Vert: 12-23=-12, 1-2=5, 2-4=10, 4-5=4, 5-6=10, 6-7=-16, 7-8=-22, 8-9=-16, 5-7=-6, 15-21=-18, 10-28=27, 11-28=7(F=-20)

Horz: 1-2=-17, 2-6=-22, 6-9=-4, 2-23=-21, 10-11=-39

Drag: 4-21=-10, 8-15=-10

Concentrated Loads (lb)

Vert: 28=134(F)

6) Dead + 0.6 MWFRS Wind (Neg. Internal) Left: Lumber Increase=1.60, Plate Increase=1.60

Uniform Loads (plf)

Vert: 12-23=-20, 1-2=-30, 2-4=-35, 4-5=-45, 5-6=-35, 6-7=-9, 7-8=-19, 8-9=-9, 5-7=-10, 15-21=-30, 10-28=-9, 11-28=-29(F=-20)

Horz: 1-2=10, 2-6=15, 6-9=11, 2-23=27, 10-11=-11

Drag: 4-21=-10, 8-15=-10

Concentrated Loads (lb)

Vert: 28=-590(F)

7) Dead + 0.6 MWFRS Wind (Neg. Internal) Right: Lumber Increase=1.60, Plate Increase=1.60

Uniform Loads (plf)

Vert: 12-23=-20, 1-2=-3, 2-4=-9, 4-5=-19, 5-6=-9, 6-7=-35, 7-8=-45, 8-9=-35, 5-7=-10, 15-21=-30, 10-28=8,

11-28=-12(F=-20)

Horz: 1-2=-17, 2-6=-11, 6-9=-15, 2-23=-9, 10-11=-28

Drag: 4-21=-10, 8-15=-10

Concentrated Loads (lb)

Vert: 28=-485(F)

8) Dead + 0.6 MWFRS Wind (Pos. Internal) 1st Parallel: Lumber Increase=1.60, Plate Increase=1.60

Uniform Loads (plf)

Vert: 12-23=-12, 1-2=22, 2-4=27, 4-5=9, 5-6=15, 6-7=5, 7-8=-1, 8-9=5, 5-7=-6, 15-21=-18, 10-28=5, 11-28=-15(F=-20)

Horz: 1-2=-34, 2-4=-39, 4-6=-27, 6-9=17, 2-23=14, 10-11=-17

Drag: 4-21=-10, 8-15=-10

Concentrated Loads (lb)

Vert: 28=134(F)

9) Dead + 0.6 MWFRS Wind (Pos. Internal) 2nd Parallel: Lumber Increase=1.60, Plate Increase=1.60

Uniform Loads (plf)

Vert: 12-23=-12, 1-2=0, 2-4=5, 4-5=-1, 5-6=5, 6-7=15, 7-8=9, 8-9=15, 5-7=-6, 15-21=-18, 10-28=15, 11-28=-5(F=-20)

Horz: 1-2=-12, 2-6=-17, 6-9=27, 2-23=-15, 10-11=-27

Drag: 4-21=-10, 8-15=-10

Concentrated Loads (lb)

Vert: 28=30(F)

10) Dead + 0.6 MWFRS Wind (Pos. Internal) 3rd Parallel: Lumber Increase=1.60, Plate Increase=1.60

Uniform Loads (plf)

Vert: 12-23=-12, 1-2=10, 2-4=15, 4-5=9, 5-6=15, 6-7=5, 7-8=-1, 8-9=5, 5-7=-6, 15-21=-18, 10-28=5, 11-28=-15(F=-20)

Horz: 1-2=-22, 2-6=-27, 6-9=17, 2-23=7, 10-11=-17

Drag: 4-21=-10, 8-15=-10

Concentrated Loads (lb)

Vert: 28=30(F)

11) Dead + 0.6 MWFRS Wind (Pos. Internal) 4th Parallel: Lumber Increase=1.60, Plate Increase=1.60

Continued on page 3

**WARNING - Verify design parameters and READ NOTES ON THIS AND INCLUDED MITEK REFERENCE PAGE MII-7473 rev. 5/19/2020 BEFORE USE.**

Design valid for use only with MiTek® connectors. This design is based only upon parameters shown, and is for an individual building component, not a truss system. Before use, the building designer must verify the applicability of design parameters and properly incorporate this design into the overall building design. Bracing indicated is to prevent buckling of individual truss web and/or chord members only. Additional temporary and permanent bracing is always required for stability and to prevent collapse with possible personal injury and property damage. For general guidance regarding the fabrication, storage, delivery, erection and bracing of trusses and truss systems, see **ANSI/TPI1 Quality Criteria, DSB-89 and BCSI Building Component Safety Information** available from Truss Plate Institute, 2670 Crain Highway, Suite 203 Waldorf, MD 20601



818 Soundside Road  
Edenton, NC 27932

Job	Truss	Truss Type	Qty	Ply	MCKEE; NELSON	144818030
MASTER_RT130	D09GR	ATTIC	1	2	Job Reference (optional)	

Builders FirstSource (Apex, NC), Apex, NC - 27523,

8.240 s Mar 9 2020 MiTek Industries, Inc. Mon Feb 15 14:20:10 2021 Page 3  
ID:f0X\_NZYOMto?npzE4iXPzyeg2c-A1v4ds7K2g8z4WuZ5Qc8sDef1Wua18m3YG6mRizksu3

**LOAD CASE(S)** Standard

- Uniform Loads (plf)  
Vert: 12-23=-12, 1-2=-0, 2-4=5, 4-5=-1, 5-6=5, 6-7=15, 7-8=9, 8-9=15, 5-7=-6, 15-21=-18, 10-28=15, 11-28=-5(F=-20)  
Horz: 1-2=-12, 2-6=-17, 6-9=27, 2-23=-15, 10-11=-27  
Drag: 4-21=-10, 8-15=-10
- Concentrated Loads (lb)  
Vert: 28=30(F)
- 12) Dead + 0.6 MWFRS Wind (Neg. Internal) 1st Parallel: Lumber Increase=1.60, Plate Increase=1.60  
Uniform Loads (plf)  
Vert: 12-23=-20, 1-2=14, 2-4=8, 4-5=-14, 5-6=-4, 6-7=-14, 7-8=-24, 8-9=-14, 5-7=-10, 15-21=-30, 10-28=-14, 11-28=-34(F=-20)  
Horz: 1-2=-34, 2-4=-28, 4-6=-16, 6-9=6, 2-23=25, 10-11=-6  
Drag: 4-21=-10, 8-15=-10
- Concentrated Loads (lb)  
Vert: 28=-568(F)
- 13) Dead + 0.6 MWFRS Wind (Neg. Internal) 2nd Parallel: Lumber Increase=1.60, Plate Increase=1.60  
Uniform Loads (plf)  
Vert: 12-23=-20, 1-2=-8, 2-4=-14, 4-5=-24, 5-6=-14, 6-7=-4, 7-8=-14, 8-9=-4, 5-7=-10, 15-21=-30, 10-28=-4, 11-28=-24(F=-20)  
Horz: 1-2=-12, 2-6=-6, 6-9=16, 2-23=-3, 10-11=-16  
Drag: 4-21=-10, 8-15=-10
- Concentrated Loads (lb)  
Vert: 28=-400(F)
- 14) Dead + Uninhab. Attic Storage + Attic Floor: Lumber Increase=1.00, Plate Increase=1.00  
Uniform Loads (plf)  
Vert: 12-23=-20, 1-2=-20, 2-4=-20, 4-5=-30, 5-6=-20, 6-7=-20, 7-8=-30, 8-9=-20, 5-7=-10, 15-21=-110, 10-28=-20, 11-28=-120(F=-100)  
Drag: 4-21=-10, 8-15=-10
- Concentrated Loads (lb)  
Vert: 28=-1050(F)
- 15) Dead + Uninhabitable Attic Storage: Lumber Increase=1.00, Plate Increase=1.00  
Uniform Loads (plf)  
Vert: 12-23=-20, 1-2=-20, 2-4=-20, 4-5=-30, 5-6=-20, 6-7=-20, 7-8=-30, 8-9=-20, 5-7=-10, 15-21=-110, 10-28=-20, 11-28=-120(F=-100)  
Drag: 4-21=-10, 8-15=-10
- Concentrated Loads (lb)  
Vert: 28=-1050(F)
- 16) Dead + 0.75 Roof Live (bal.) + 0.75 Uninhab. Attic Storage + 0.75 Attic Floor + 0.75(0.6 MWFRS Wind (Neg. Int) Left): Lumber Increase=1.60, Plate Increase=1.60  
Uniform Loads (plf)  
Vert: 12-23=-20, 1-2=-57, 2-4=-62, 4-5=-72, 5-6=-62, 6-7=-42, 7-8=-52, 8-9=-42, 5-7=-10, 15-21=-90, 10-28=-42, 11-28=-122(F=-80)  
Horz: 1-2=7, 2-6=12, 6-9=8, 2-23=21, 10-11=-8  
Drag: 4-21=-10, 8-15=-10
- Concentrated Loads (lb)  
Vert: 28=-1317(F)
- 17) Dead + 0.75 Roof Live (bal.) + 0.75 Uninhab. Attic Storage + 0.75 Attic Floor + 0.75(0.6 MWFRS Wind (Neg. Int) Right): Lumber Increase=1.60, Plate Increase=1.60  
Uniform Loads (plf)  
Vert: 12-23=-20, 1-2=-38, 2-4=-42, 4-5=-52, 5-6=-42, 6-7=-62, 7-8=-72, 8-9=-62, 5-7=-10, 15-21=-90, 10-28=-29, 11-28=-109(F=-80)  
Horz: 1-2=-12, 2-6=-8, 6-9=-12, 2-23=-7, 10-11=-21  
Drag: 4-21=-10, 8-15=-10
- Concentrated Loads (lb)  
Vert: 28=-1239(F)
- 18) Dead + 0.75 Roof Live (bal.) + 0.75 Uninhab. Attic Storage + 0.75 Attic Floor + 0.75(0.6 MWFRS Wind (Neg. Int) 1st Parallel): Lumber Increase=1.60, Plate Increase=1.60  
Uniform Loads (plf)  
Vert: 12-23=-20, 1-2=-25, 2-4=-29, 4-5=-48, 5-6=-38, 6-7=-46, 7-8=-56, 8-9=-46, 5-7=-10, 15-21=-90, 10-28=-46, 11-28=-126(F=-80)  
Horz: 1-2=-25, 2-4=-21, 4-6=-12, 6-9=4, 2-23=19, 10-11=-4  
Drag: 4-21=-10, 8-15=-10
- Concentrated Loads (lb)  
Vert: 28=-1301(F)
- 19) Dead + 0.75 Roof Live (bal.) + 0.75 Uninhab. Attic Storage + 0.75 Attic Floor + 0.75(0.6 MWFRS Wind (Neg. Int) 2nd Parallel): Lumber Increase=1.60, Plate Increase=1.60  
Uniform Loads (plf)  
Vert: 12-23=-20, 1-2=-41, 2-4=-46, 4-5=-56, 5-6=-46, 6-7=-38, 7-8=-48, 8-9=-38, 5-7=-10, 15-21=-90, 10-28=-38, 11-28=-118(F=-80)  
Horz: 1-2=-9, 2-6=-4, 6-9=12, 2-23=-3, 10-11=-12  
Drag: 4-21=-10, 8-15=-10
- Concentrated Loads (lb)  
Vert: 28=-1175(F)
- 20) 1st Dead + Roof Live (unbalanced): Lumber Increase=1.15, Plate Increase=1.15  
Uniform Loads (plf)  
Vert: 12-23=-20, 1-2=-60, 2-4=-60, 4-5=-70, 5-6=-60, 6-7=-20, 7-8=-30, 8-9=-20, 5-7=-10, 15-21=-30, 10-28=-20, 11-28=-40(F=-20)  
Drag: 4-21=-10, 8-15=-10
- Concentrated Loads (lb)  
Vert: 28=-700(F)
- 21) 2nd Dead + Roof Live (unbalanced): Lumber Increase=1.15, Plate Increase=1.15

Continued on page 4

**WARNING** - Verify design parameters and READ NOTES ON THIS AND INCLUDED MITEK REFERENCE PAGE MII-7473 rev. 5/19/2020 BEFORE USE.  
Design valid for use only with MiTek® connectors. This design is based only upon parameters shown, and is for an individual building component, not a truss system. Before use, the building designer must verify the applicability of design parameters and properly incorporate this design into the overall building design. Bracing indicated is to prevent buckling of individual truss web and/or chord members only. Additional temporary and permanent bracing is always required for stability and to prevent collapse with possible personal injury and property damage. For general guidance regarding the fabrication, storage, delivery, erection and bracing of trusses and truss systems, see **ANSI/TPI1 Quality Criteria, DSB-89 and BCSI Building Component Safety Information** available from Truss Plate Institute, 2670 Crain Highway, Suite 203 Waldorf, MD 20601



818 Soundside Road  
Edenton, NC 27932

Job MASTER_RT130	Truss D09GR	Truss Type ATTIC	Qty 1	Ply <b>2</b>	MCKEE; NELSON Job Reference (optional)	I44818030
---------------------	----------------	---------------------	----------	-----------------	---	-----------

Builders FirstSource (Apex, NC), Apex, NC - 27523,

8.240 s Mar 9 2020 MiTek Industries, Inc. Mon Feb 15 14:20:10 2021 Page 4  
ID:f0X\_NZYyOMto?npzE4iXPzyeg2c-A1v4ds7K2g8z4WuZ5Qc8sDef1Wua18m3YG6mRizksu3

**LOAD CASE(S)** Standard

Uniform Loads (plf)

Vert: 12-23=-20, 1-2=-20, 2-4=-20, 4-5=-30, 5-6=-20, 6-7=-60, 7-8=-70, 8-9=-60, 5-7=-10, 15-21=-30, 10-28=-60, 11-28=-80(F=-20)

Drag: 4-21=-10, 8-15=-10

Concentrated Loads (lb)

Vert: 28=-700(F)

22) 3rd Dead + 0.75 Roof Live (unbalanced) + 0.75 Uninhab. Attic Storage + 0.75 Attic Floor: Lumber Increase=1.15, Plate Increase=1.15

Uniform Loads (plf)

Vert: 12-23=-20, 1-2=-50, 2-4=-50, 4-5=-60, 5-6=-50, 6-7=-20, 7-8=-30, 8-9=-20, 5-7=-10, 15-21=-90, 10-28=-20, 11-28=-100(F=-80)

Drag: 4-21=-10, 8-15=-10

Concentrated Loads (lb)

Vert: 28=-1138(F)

23) 4th Dead + 0.75 Roof Live (unbalanced) + 0.75 Uninhab. Attic Storage + 0.75 Attic Floor: Lumber Increase=1.15, Plate Increase=1.15

Uniform Loads (plf)

Vert: 12-23=-20, 1-2=-20, 2-4=-20, 4-5=-30, 5-6=-20, 6-7=-50, 7-8=-60, 8-9=-50, 5-7=-10, 15-21=-90, 10-28=-50, 11-28=-130(F=-80)

Drag: 4-21=-10, 8-15=-10

Concentrated Loads (lb)

Vert: 28=-1138(F)

**WARNING** - Verify design parameters and READ NOTES ON THIS AND INCLUDED MITEK REFERENCE PAGE MII-7473 rev. 5/19/2020 BEFORE USE.

Design valid for use only with MiTek® connectors. This design is based only upon parameters shown, and is for an individual building component, not a truss system. Before use, the building designer must verify the applicability of design parameters and properly incorporate this design into the overall building design. Bracing indicated is to prevent buckling of individual truss web and/or chord members only. Additional temporary and permanent bracing is always required for stability and to prevent collapse with possible personal injury and property damage. For general guidance regarding the fabrication, storage, delivery, erection and bracing of trusses and truss systems, see **ANSI/TPI1 Quality Criteria, DSB-89 and BCSI Building Component Safety Information** available from Truss Plate Institute, 2670 Crain Highway, Suite 203 Waldorf, MD 20601



818 Soundside Road  
Edenton, NC 27932

Job MASTER_RT130	Truss E03	Truss Type MONO TRUSS	Qty 1	Ply 1	MCKEE; NELSON	144818031
---------------------	--------------	--------------------------	----------	----------	---------------	-----------

Builders FirstSource (Apex, NC), Apex, NC - 27523, 8.240 s Mar 9 2020 MiTek Industries, Inc. Mon Feb 15 14:20:11 2021 Page 1

ID:foX\_NZYyOMto?npzE4iXPzeg2c-eDSSrC8ypzHqigTif87NPQAp\_wAumaaCmwsJ\_8zksu2

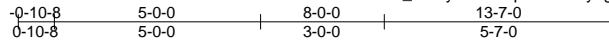

Scale = 1:55.9

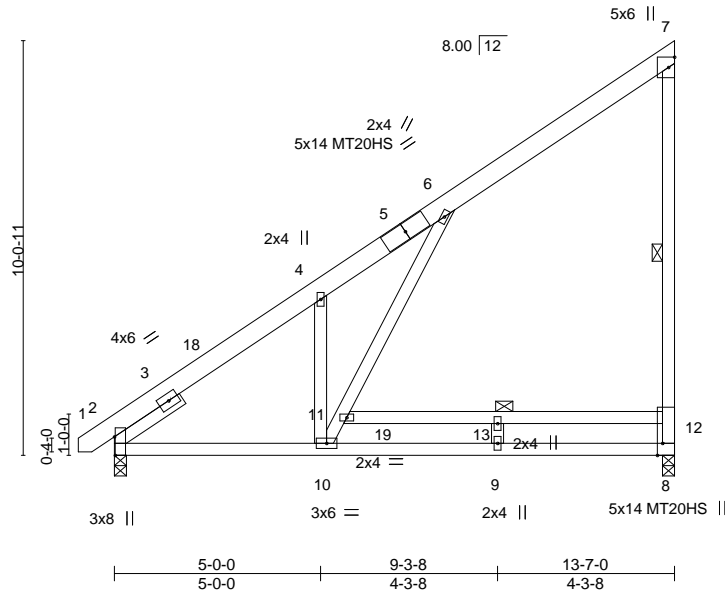

Plate Offsets (X, Y)-- [2:0-5-6,Edge], [8:0-3-8,Edge], [8:0-0-0,0-1-12], [12:0-1-12,0-0-0]

LOADING (psf)	SPACING-	CSI.	DEFL.	PLATES	GRIP
TCLL 20.0	2-0-0	TC 0.97	in (loc) l/defl L/d	MT20	244/190
TCDL 10.0	Plate Grip DOL 1.15	BC 0.87	Vert(LL) -0.35 9-10 >467 360	MT20HS	187/143
BCLL 0.0 *	Lumber DOL 1.15	WB 0.78	Horz(CT) 0.05 2 n/a n/a		
BCDL 10.0	Rep Stress Incr NO	Matrix-MS	Wind(LL) 0.35 9-10 >465 240		
	Code IRC2015/TP12014			Weight: 105 lb	FT = 20%

**LUMBER-**  
TOP CHORD 2x6 SP DSS \*Except\*  
1-5: 2x6 SP No.2  
BOT CHORD 2x4 SP No.2  
WEBS 2x4 SP No.2 \*Except\*  
4-10: 2x4 SP No.3  
SLIDER Left 2x4 SP No.3 1-11-12

**BRACING-**  
TOP CHORD Structural wood sheathing directly applied or 2-6-7 oc purlins, except end verticals.  
BOT CHORD Rigid ceiling directly applied or 10-0-0 oc bracing.  
WEBS 1 Row at midpt 7-8, 11-12

**REACTIONS.** (size) 8=0-3-8, 2=0-3-8  
Max Horz 2=368(LC 11)  
Max Uplift 8=-171(LC 12), 2=-51(LC 12)  
Max Grav 8=755(LC 19), 2=594(LC 20)

**FORCES.** (lb) - Max. Comp./Max. Ten. - All forces 250 (lb) or less except when shown.  
TOP CHORD 2-4=-712/113, 4-6=-993/312, 6-7=-249/355, 8-12=-600/244, 7-12=-535/258  
BOT CHORD 2-10=-279/668  
WEBS 4-10=-964/498, 10-11=-435/1096, 6-11=-426/1176, 11-13=-346/238, 12-13=-346/238

- NOTES-**
- 1) Wind: ASCE 7-10; Vult=130mph (3-second gust) Vasd=103mph; TCDL=6.0psf; BCDL=6.0psf; h=32ft; Cat. II; Exp B; Enclosed; MWFRS (envelope) gable end zone and C-C Exterior(2) -0-8-9 to 2-3-7, Interior(1) 2-3-7 to 13-5-4 zone; cantilever left and right exposed; end vertical left and right exposed; C-C for members and forces & MWFRS for reactions shown; Lumber DOL=1.60 plate grip DOL=1.60
  - 2) All plates are MT20 plates unless otherwise indicated.
  - 3) This truss has been designed for a 10.0 psf bottom chord live load nonconcurrent with any other live loads.
  - 4) \* This truss has been designed for a live load of 20.0psf on the bottom chord in all areas where a rectangle 3-6-0 tall by 2-0-0 wide will fit between the bottom chord and any other members.
  - 5) Provide mechanical connection (by others) of truss to bearing plate capable of withstanding 100 lb uplift at joint(s) 2 except (jt=lb) 8=171.
  - 6) N/A
  - 7) In the LOAD CASE(S) section, loads applied to the face of the truss are noted as front (F) or back (B).

**LOAD CASE(S)** Standard  
1) Dead + Roof Live (balanced): Lumber Increase=1.15, Plate Increase=1.15  
Uniform Loads (plf)  
Vert: 1-7=-60, 8-14=-20  
2) Dead + 0.75 Roof Live (balanced) + 0.75 Uninhab. Attic Storage: Lumber Increase=1.15, Plate Increase=1.15  
Uniform Loads (plf)  
Vert: 1-7=-50, 8-14=-20, 12-19=-30(F)



February 15, 2021

Continued on page 2

**WARNING - Verify design parameters and READ NOTES ON THIS AND INCLUDED MITEK REFERENCE PAGE MII-7473 rev. 5/19/2020 BEFORE USE.**  
Design valid for use only with MiTek® connectors. This design is based only upon parameters shown, and is for an individual building component, not a truss system. Before use, the building designer must verify the applicability of design parameters and properly incorporate this design into the overall building design. Bracing indicated is to prevent buckling of individual truss web and/or chord members only. Additional temporary and permanent bracing is always required for stability and to prevent collapse with possible personal injury and property damage. For general guidance regarding the fabrication, storage, delivery, erection and bracing of trusses and truss systems, see **ANSI/TPI1 Quality Criteria, DSB-89 and BCSI Building Component Safety Information** available from Truss Plate Institute, 2670 Crain Highway, Suite 203 Waldorf, MD 20601

ENGINEERING BY  
**TRENCO**  
A MiTek Affiliate  
818 Soundside Road  
Edenton, NC 27932

Job	Truss	Truss Type	Qty	Ply	MCKEE; NELSON	I44818031
MASTER_RT130	E03	MONO TRUSS	1	1	Job Reference (optional)	

Builders FirstSource (Apex, NC), Apex, NC - 27523,

8.240 s Mar 9 2020 MiTek Industries, Inc. Mon Feb 15 14:20:11 2021 Page 2  
ID:f0X\_NZYyOMto?npzE4iXPzyeg2c-eDSSrC8ypzHqigTif87NPQAp\_wAumaaCmwsJ\_8zksu2

**LOAD CASE(S)** Standard

- 3) Dead + Uninhabitable Attic Without Storage: Lumber Increase=1.25, Plate Increase=1.25  
Uniform Loads (plf)  
Vert: 1-7=-20, 8-14=-40, 12-19=-40(F)
- 18) Dead + Uninhabitable Attic Storage: Lumber Increase=0.90, Plate Increase=0.90 Plt. metal=0.90  
Uniform Loads (plf)  
Vert: 1-7=-20, 8-14=-20, 12-19=-40(F)
- 19) Dead + 0.75 Roof Live (bal.) + 0.75 Uninhab. Attic Storage + 0.75(0.6 MWFRS Wind (Neg. Int) Left): Lumber Increase=1.60, Plate Increase=1.60  
Uniform Loads (plf)  
Vert: 1-2=-56, 2-7=-61, 8-14=-20, 12-19=-30(F)  
Horz: 1-2=6, 2-7=11, 7-8=7
- 20) Dead + 0.75 Roof Live (bal.) + 0.75 Uninhab. Attic Storage + 0.75(0.6 MWFRS Wind (Neg. Int) Right): Lumber Increase=1.60, Plate Increase=1.60  
Uniform Loads (plf)  
Vert: 1-2=-37, 2-7=-42, 8-14=-20, 12-19=-30(F)  
Horz: 1-2=-13, 2-7=-8, 7-8=-21
- 21) Dead + 0.75 Roof Live (bal.) + 0.75 Uninhab. Attic Storage + 0.75(0.6 MWFRS Wind (Neg. Int) 1st Parallel): Lumber Increase=1.60, Plate Increase=1.60  
Uniform Loads (plf)  
Vert: 1-2=-25, 2-7=-29, 8-14=-20, 12-19=-30(F)  
Horz: 1-2=-25, 2-7=-21, 7-8=6
- 22) Dead + 0.75 Roof Live (bal.) + 0.75 Uninhab. Attic Storage + 0.75(0.6 MWFRS Wind (Neg. Int) 2nd Parallel): Lumber Increase=1.60, Plate Increase=1.60  
Uniform Loads (plf)  
Vert: 1-2=-37, 2-7=-42, 8-14=-20, 12-19=-30(F)  
Horz: 1-2=-13, 2-7=-8, 7-8=-19

**WARNING - Verify design parameters and READ NOTES ON THIS AND INCLUDED MITEK REFERENCE PAGE MII-7473 rev. 5/19/2020 BEFORE USE.**

Design valid for use only with MiTek® connectors. This design is based only upon parameters shown, and is for an individual building component, not a truss system. Before use, the building designer must verify the applicability of design parameters and properly incorporate this design into the overall building design. Bracing indicated is to prevent buckling of individual truss web and/or chord members only. Additional temporary and permanent bracing is always required for stability and to prevent collapse with possible personal injury and property damage. For general guidance regarding the fabrication, storage, delivery, erection and bracing of trusses and truss systems, see **ANSI/TPI1 Quality Criteria, DSB-89 and BCSI Building Component Safety Information** available from Truss Plate Institute, 2670 Crain Highway, Suite 203 Waldorf, MD 20601



818 Soundside Road  
Edenton, NC 27932

Job MASTER_RT130	Truss E03A	Truss Type MONO TRUSS	Qty 1	Ply 1	MCKEE; NELSON	144818032
---------------------	---------------	--------------------------	----------	----------	---------------	-----------

Builders FirstSource (Apex, NC), Apex, NC - 27523,

8.240 s Mar 9 2020 MiTek Industries, Inc. Mon Feb 15 14:20:11 2021 Page 1

ID:f0X\_NZYyOMto?npzE4iXPzyeg2c-eDSSrC8ypzHqjTlf87NPQAsNwFHmbvCmwsJ\_8zksu2

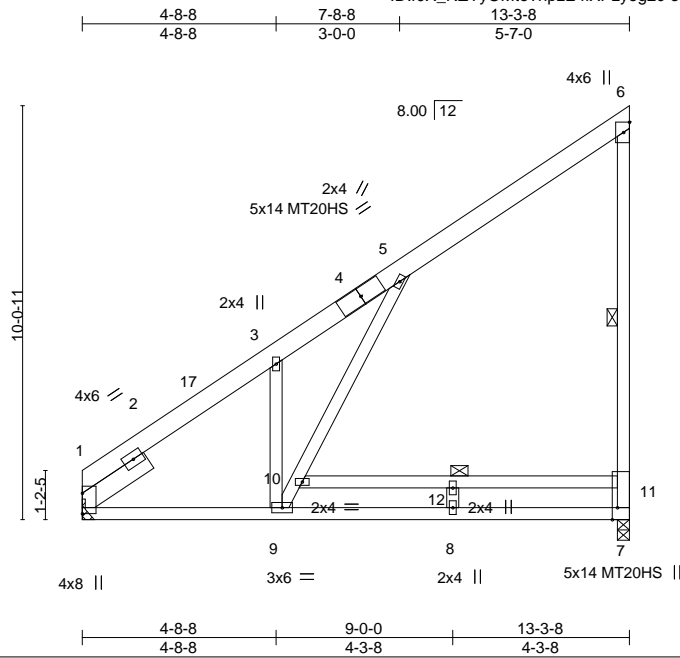

Plate Offsets (X,Y)--	[7:0-0-0,0-1-12], [7:0-3-8,Edge], [11:0-1-12,0-0-0]
-----------------------	---

LOADING (psf)	SPACING-	2-0-0	CSI.	DEFL.	in (loc)	l/defl	L/d	PLATES	GRIP	
TCLL 20.0	Plate Grip DOL	1.15	TC 0.82	Vert(LL)	-0.23	8-9	>672	360	MT20	244/190
TCDL 10.0	Lumber DOL	1.15	BC 0.53	Vert(CT)	-0.45	8-9	>348	240	MT20HS	187/143
BCLL 0.0 *	Rep Stress Incr	YES	WB 0.76	Horz(CT)	0.07	1	n/a	n/a		
BCDL 10.0	Code IRC2015/TPI2014		Matrix-MS	Wind(LL)	0.33	8-9	>477	240		
									Weight: 103 lb	FT = 20%

LUMBER-	BRACING-
TOP CHORD 2x6 SP DSS *Except* 1-4: 2x6 SP No.2	TOP CHORD Structural wood sheathing directly applied or 3-5-6 oc purlins, except end verticals.
BOT CHORD 2x4 SP No.2	BOT CHORD Rigid ceiling directly applied or 10-0-0 oc bracing.
WEBS 2x4 SP No.2 *Except* 3-9: 2x4 SP No.3	WEBS 1 Row at midpt 6-7, 10-11
SLIDER Left 2x6 SP No.2 1-11-12	

**REACTIONS.** (size) 7=0-3-8, 1=Mechanical  
 Max Horz 1=358(LC 11)  
 Max Uplift 7=-170(LC 12), 1=-32(LC 12)  
 Max Grav 7=591(LC 19), 1=526(LC 1)

**FORCES.** (lb) - Max. Comp./Max. Ten. - All forces 250 (lb) or less except when shown.  
 TOP CHORD 1-3=-580/141, 3-5=-881/306, 5-6=-251/353, 7-11=-545/248, 6-11=-529/261  
 BOT CHORD 1-9=-287/651  
 WEBS 3-9=-940/493, 9-10=-451/1060, 5-10=-418/1074, 10-12=-346/239, 11-12=-346/239

- NOTES-**
- 1) Wind: ASCE 7-10; Vult=130mph (3-second gust) Vasd=103mph; TCDL=6.0psf; BCDL=6.0psf; h=32ft; Cat. II; Exp B; Enclosed; MWFRS (envelope) gable end zone and C-C Exterior(2) 0-3-8 to 3-3-8, Interior(1) 3-3-8 to 13-5-4 zone; cantilever left and right exposed; end vertical left and right exposed; C-C for members and forces & MWFRS for reactions shown; Lumber DOL=1.60 plate grip DOL=1.60
  - 2) All plates are MT20 plates unless otherwise indicated.
  - 3) This truss has been designed for a 10.0 psf bottom chord live load nonconcurrent with any other live loads.
  - 4) \* This truss has been designed for a live load of 20.0psf on the bottom chord in all areas where a rectangle 3-6-0 tall by 2-0-0 wide will fit between the bottom chord and any other members.
  - 5) Refer to girder(s) for truss to truss connections.
  - 6) Provide mechanical connection (by others) of truss to bearing plate capable of withstanding 100 lb uplift at joint(s) 1 except (jt=lb) 7=170.



February 15, 2021

**WARNING - Verify design parameters and READ NOTES ON THIS AND INCLUDED MITEK REFERENCE PAGE MII-7473 rev. 5/19/2020 BEFORE USE.**  
 Design valid for use only with MiTek® connectors. This design is based only upon parameters shown, and is for an individual building component, not a truss system. Before use, the building designer must verify the applicability of design parameters and properly incorporate this design into the overall building design. Bracing indicated is to prevent buckling of individual truss web and/or chord members only. Additional temporary and permanent bracing is always required for stability and to prevent collapse with possible personal injury and property damage. For general guidance regarding the fabrication, storage, delivery, erection and bracing of trusses and truss systems, see **ANSI/TPI1 Quality Criteria, DSB-89 and BCSI Building Component Safety Information** available from Truss Plate Institute, 2670 Crain Highway, Suite 203 Waldorf, MD 20601

ENGINEERING BY  
**TRENCO**  
 A MiTek Affiliate  
 818 Soundside Road  
 Edenton, NC 27932



Job MASTER_RT130	Truss E05	Truss Type MONO TRUSS	Qty 1	Ply 1	MCKEE; NELSON	144818033
---------------------	--------------	--------------------------	----------	----------	---------------	-----------

Builders FirstSource (Apex, NC),

Apex, NC - 27523,

8.240 s Mar 9 2020 MiTek Industries, Inc. Mon Feb 15 14:20:12 2021 Page 1

ID:f0X\_NZYyOMto?npzE4iXPzyeg2c-6P0q2Y9aaHPhJp2xDrecxej1iJd\_V1WM?absWbzkusu1

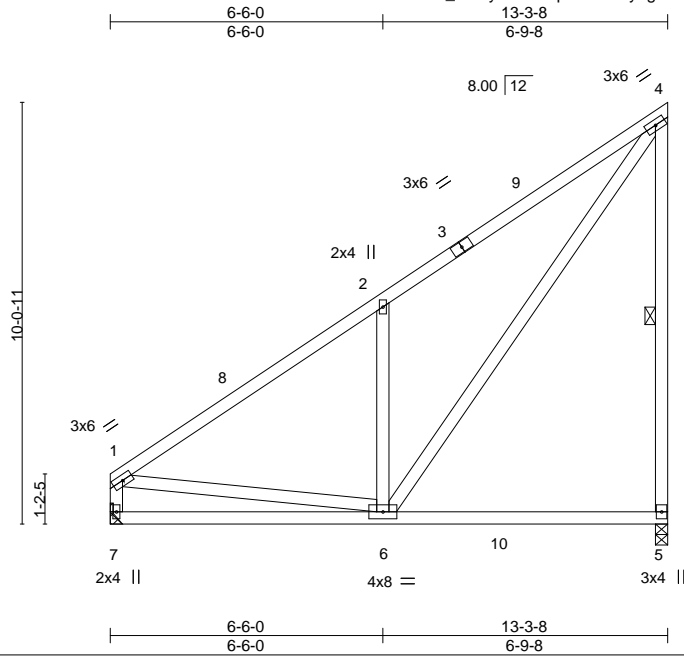

Scale = 1:54.9

LOADING (psf)	SPACING-	2-0-0	CSI.	DEFL.	in (loc)	l/defl	L/d	PLATES	GRIP
TCLL 20.0	Plate Grip DOL	1.15	TC 0.78	Vert(LL)	-0.09 5-6	>999	360	MT20	244/190
TCDL 10.0	Lumber DOL	1.15	BC 0.43	Vert(CT)	-0.14 5-6	>999	240		
BCLL 0.0 *	Rep Stress Incr	YES	WB 0.80	Horz(CT)	0.01 5	n/a	n/a		
BCDL 10.0	Code IRC2015/TPI2014		Matrix-MS	Wind(LL)	0.05 5-6	>999	240		
								Weight: 92 lb	FT = 20%

**LUMBER-**

TOP CHORD 2x4 SP No.2  
 BOT CHORD 2x4 SP No.2  
 WEBS 2x4 SP No.3 \*Except\*  
 4-5: 2x4 SP No.2

**BRACING-**

TOP CHORD Structural wood sheathing directly applied or 6-0-0 oc purlins, except end verticals.  
 BOT CHORD Rigid ceiling directly applied or 7-11-9 oc bracing.  
 WEBS 1 Row at midpt 4-5

**REACTIONS.**

(size) 7=Mechanical, 5=0-3-8  
 Max Horz 7=369(LC 9)  
 Max Uplift 7=-30(LC 12), 5=-170(LC 12)  
 Max Grav 7=522(LC 20), 5=687(LC 19)

**FORCES.** (lb) - Max. Comp./Max. Ten. - All forces 250 (lb) or less except when shown.

TOP CHORD 1-7=-476/122, 1-2=-622/119, 2-4=-659/293, 4-5=-593/288  
 BOT CHORD 6-7=-531/642  
 WEBS 2-6=-511/323, 4-6=-314/783, 1-6=-65/384

**NOTES-**

- 1) Wind: ASCE 7-10; Vult=130mph (3-second gust) Vasd=103mph; TC DL=6.0psf; BCDL=6.0psf; h=32ft; Cat. II; Exp B; Enclosed; MWFRS (envelope) gable end zone and C-C Exterior(2) 0-5-4 to 3-5-4, Interior(1) 3-5-4 to 13-5-4 zone; cantilever left and right exposed; end vertical left and right exposed; C-C for members and forces & MWFRS for reactions shown; Lumber DOL=1.60 plate grip DOL=1.60
- 2) This truss has been designed for a 10.0 psf bottom chord live load nonconcurrent with any other live loads.
- 3) \* This truss has been designed for a live load of 20.0psf on the bottom chord in all areas where a rectangle 3-6-0 tall by 2-0-0 wide will fit between the bottom chord and any other members, with BCDL = 10.0psf.
- 4) Refer to girder(s) for truss to truss connections.
- 5) Provide mechanical connection (by others) of truss to bearing plate capable of withstanding 100 lb uplift at joint(s) 7 except (jt=lb) 5=170.



February 15, 2021

**WARNING - Verify design parameters and READ NOTES ON THIS AND INCLUDED MITEK REFERENCE PAGE MII-7473 rev. 5/19/2020 BEFORE USE.**

Design valid for use only with MiTek® connectors. This design is based only upon parameters shown, and is for an individual building component, not a truss system. Before use, the building designer must verify the applicability of design parameters and properly incorporate this design into the overall building design. Bracing indicated is to prevent buckling of individual truss web and/or chord members only. Additional temporary and permanent bracing is always required for stability and to prevent collapse with possible personal injury and property damage. For general guidance regarding the fabrication, storage, delivery, erection and bracing of trusses and truss systems, see

**ANSI/TPI1 Quality Criteria, DSB-89 and BCSI Building Component**

**Safety Information** available from Truss Plate Institute, 2670 Crain Highway, Suite 203 Waldorf, MD 20601



818 Soundside Road  
 Edenton, NC 27932

Job MASTER_RT130	Truss L01SG	Truss Type FINK	Qty 1	Ply 1	MCKEE; NELSON	144818034
---------------------	----------------	--------------------	----------	----------	---------------	-----------

Builders FirstSource (Apex, NC), Apex, NC - 27523, 8.240 s Mar 9 2020 MiTek Industries, Inc. Mon Feb 15 14:20:13 2021 Page 1

ID:f0X\_NZYyOMto?npzE4iXPzyeg2c-bcaDGu9CLbXXzdz8nY9rUGG7j\_zEatVEELQ21zksu0

0-10-8 5-2-8 5-9-10 9-5-8 13-1-6 18-11-0 19-9-8  
0-10-8 5-2-8 0-7-2 3-7-14 3-7-14 5-9-10 0-10-8

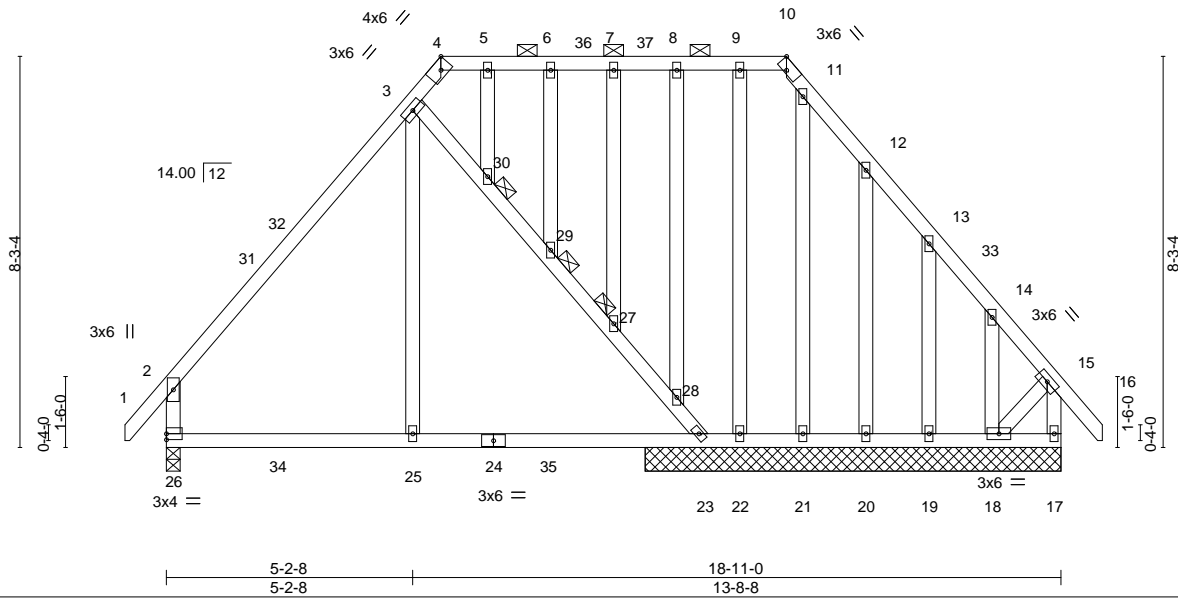

Scale = 1:48.7

Plate Offsets (X,Y)--	[4:0-2-11,Edge], [10:0-2-11,Edge]				
<b>LOADING</b> (psf)	<b>SPACING-</b> 2-0-0	<b>CSI.</b>	<b>DEFL.</b> in (loc) l/defl L/d	<b>PLATES</b>	<b>GRIP</b>
TCLL 20.0	Plate Grip DOL 1.15	TC 0.55	Vert(LL) -0.03 23-25 >999 360	MT20	244/190
TCDL 10.0	Lumber DOL 1.15	BC 0.32	Vert(CT) -0.06 23-25 >999 240		
BCLL 0.0 *	Rep Stress Incr NO	WB 0.41	Horz(CT) -0.01 17 n/a n/a		
BCDL 10.0	Code IRC2015/TPI2014	Matrix-MS	Wind(LL) -0.03 23-25 >999 240	Weight: 169 lb	FT = 20%

<b>LUMBER-</b>	<b>BRACING-</b>
TOP CHORD 2x4 SP No.2	TOP CHORD Structural wood sheathing directly applied or 6-0-0 oc purlins, except end verticals, and 2-0-0 oc purlins (6-0-0 max.): 4-10.
BOT CHORD 2x4 SP No.2	BOT CHORD Rigid ceiling directly applied or 6-0-0 oc bracing, Except: 10-0-0 oc bracing: 25-26,23-25.
WEBS 2x4 SP No.3	JOINTS 1 Brace at Jt(s): 27, 29, 30

**REACTIONS.** All bearings 8-9-8 except (jt=length) 26=0-3-8.  
 (lb) - Max Horz 26=-254(LC 10)  
 Max Uplift All uplift 100 lb or less at joint(s) 26, 19 except 22=-110(LC 9), 20=-109(LC 13), 18=-219(LC 13), 17=-294(LC 11)  
 Max Grav All reactions 250 lb or less at joint(s) 22, 21, 20, 19, 17 except 26=480(LC 19), 23=676(LC 25), 18=296(LC 20)

**FORCES.** (lb) - Max. Comp./Max. Ten. - All forces 250 (lb) or less except when shown.  
 TOP CHORD 2-3=-385/157, 14-15=-140/255, 2-26=-418/202, 15-17=-197/299  
 BOT CHORD 25-26=-170/298, 23-25=-170/298  
 WEBS 3-30=-430/135, 29-30=-408/53, 27-29=-435/85, 27-28=-421/99, 23-28=-472/93, 3-25=0/287, 15-18=-260/199

- NOTES-**
- Unbalanced roof live loads have been considered for this design.
  - Wind: ASCE 7-10; Vult=130mph (3-second gust) Vasd=103mph; TCDL=6.0psf; BCDL=6.0psf; h=32ft; Cat. II; Exp B; Enclosed; MWFRS (envelope) gable end zone and C-C Exterior(2) -0-9-15 to 2-2-1, Interior(1) 2-2-1 to 5-9-10, Exterior(2) 5-9-10 to 8-9-10, Interior(1) 8-9-10 to 13-1-6, Exterior(2) 13-1-6 to 16-1-8, Interior(1) 16-1-8 to 19-8-15 zone; cantilever left and right exposed; end vertical left and right exposed; C-C for members and forces & MWFRS for reactions shown; Lumber DOL=1.60 plate grip DOL=1.60
  - Provide adequate drainage to prevent water ponding.
  - All plates are 2x4 MT20 unless otherwise indicated.
  - This truss has been designed for a 10.0 psf bottom chord live load nonconcurrent with any other live loads.
  - \* This truss has been designed for a live load of 20.0psf on the bottom chord in all areas where a rectangle 3-6-0 tall by 2-0-0 wide will fit between the bottom chord and any other members, with BCDL = 10.0psf.
  - Provide mechanical connection (by others) of truss to bearing plate capable of withstanding 100 lb uplift at joint(s) 26, 19 except (jt=lb) 22=110, 20=109, 18=219, 17=294.
  - Graphical purlin representation does not depict the size or the orientation of the purlin along the top and/or bottom chord.



February 15, 2021

Job MASTER_RT130	Truss L02GR	Truss Type HIP	Qty 1	Ply 2	MCKEE; NELSON	144818035
---------------------	----------------	-------------------	----------	----------	---------------	-----------

Builders FirstSource (Apex, NC), Apex, NC - 27523,

8.240 s Mar 9 2020 MiTek Industries, Inc. Mon Feb 15 14:20:14 2021 Page 1

ID:f0X\_NZYyOMto?npzE4iXPzyeg2c-3o8bTEAq6ufOZ7BKKGg413oWf7Mxz1YfSu4zaTzksu?



Scale = 1:52.8

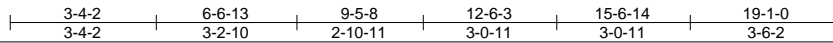
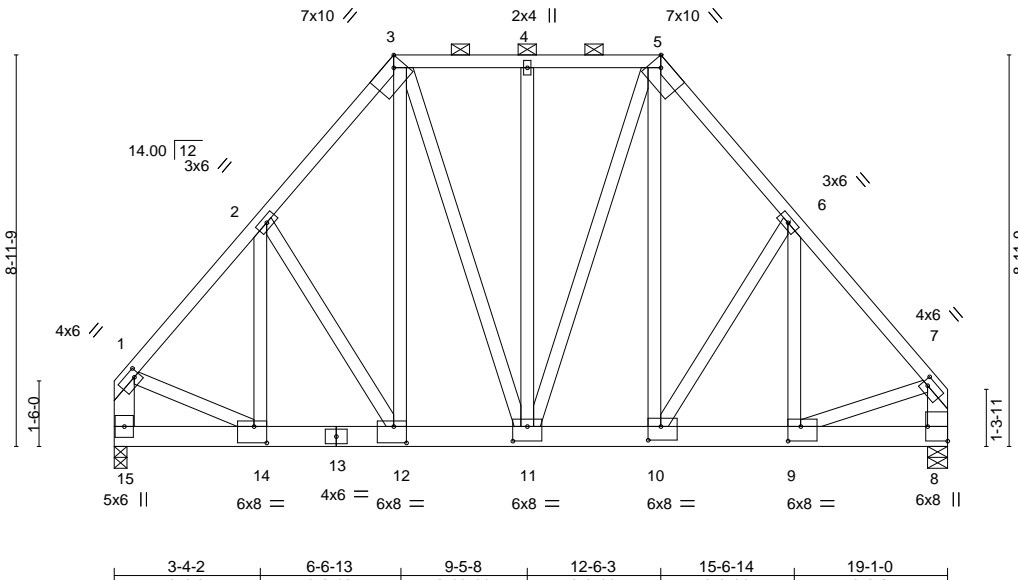

Plate Offsets (X, Y)-- [1:0-1-8,0-2-0], [3:0-2-11,Edge], [5:0-2-11,Edge], [7:0-1-8,0-2-0], [8:Edge,0-5-8], [9:0-3-8,0-4-0], [10:0-3-8,0-3-12], [11:0-4-0,0-4-0], [12:0-3-8,0-4-8], [14:0-3-8,0-4-8]

<b>LOADING</b> (psf)	<b>SPACING-</b>	2-0-0	<b>CSI.</b>	<b>DEFL.</b>	in	(loc)	l/defl	L/d	<b>PLATES</b>	<b>GRIP</b>
TCLL 20.0	Plate Grip DOL	1.15	TC 0.24	Vert(LL)	-0.04	9-10	>999	360	MT20	244/190
TCDL 10.0	Lumber DOL	1.15	BC 0.21	Vert(CT)	-0.08	9-10	>999	240		
BCLL 0.0 *	Rep Stress Incr	NO	WB 0.39	Horz(CT)	0.02	8	n/a	n/a		
BCDL 10.0	Code IRC2015/TPI2014		Matrix-MS	Wind(LL)	0.04	9-10	>999	240	Weight: 381 lb	FT = 20%

**LUMBER-**  
 TOP CHORD 2x4 SP No.2  
 BOT CHORD 2x6 SP DSS  
 WEBS 2x4 SP No.2 \*Except\*  
 1-15,7-8: 2x6 SP No.2

**BRACING-**  
 TOP CHORD Structural wood sheathing directly applied or 5-4-4 oc purlins, except end verticals, and 2-0-0 oc purlins (6-0-0 max.): 3-5.  
 BOT CHORD Rigid ceiling directly applied or 10-0-0 oc bracing.

**REACTIONS.** (size) 15=0-3-8 (req. 0-3-13), 8=0-5-8  
 Max Horz 15=240(LC 4)  
 Max Uplift 15=1073(LC 8), 8=1074(LC 9)  
 Max Grav 15=6501(LC 15), 8=6499(LC 15)

SUPPLEMENTARY BEARING PLATES, SPECIAL ANCHORAGE, OR OTHER MEANS TO ALLOW FOR THE MINIMUM REQUIRED SUPPORT WIDTH (SUCH AS COLUMN CAPS, BEARING BLOCKS, ETC.) ARE THE RESPONSIBILITY OF THE TRUSS MANUFACTURER OR THE BUILDING DESIGNER.

**FORCES.** (lb) - Max. Comp./Max. Ten. - All forces 250 (lb) or less except when shown.  
 TOP CHORD 1-15=-5473/919, 1-2=-5404/921, 2-3=-4930/947, 3-4=-3574/720, 4-5=-3574/720, 5-6=-4957/959, 6-7=-5630/955, 7-8=-5401/909  
 BOT CHORD 14-15=-276/488, 12-14=-699/3606, 11-12=-607/3268, 10-11=-556/3266, 9-10=-570/3637, 8-9=-103/429  
 WEBS 1-14=-540/3384, 2-14=-121/733, 2-12=-701/267, 3-12=-498/2512, 3-11=-297/1214, 5-11=-280/1124, 5-10=-527/2563, 6-10=-824/303, 6-9=-162/992, 7-9=-536/3390

**NOTES-**

- 2-ply truss to be connected together with 10d (0.131"x3") nails as follows:  
 Top chords connected as follows: 2x6 - 2 rows staggered at 0-9-0 oc, 2x4 - 1 row at 0-9-0 oc.  
 Bottom chords connected as follows: 2x6 - 2 rows staggered at 0-9-0 oc.  
 Webs connected as follows: 2x4 - 1 row at 0-9-0 oc.
- All loads are considered equally applied to all plies, except if noted as front (F) or back (B) face in the LOAD CASE(S) section. Ply to ply connections have been provided to distribute only loads noted as (F) or (B), unless otherwise indicated.
- Unbalanced roof live loads have been considered for this design.
- Wind: ASCE 7-10; Vult=130mph (3-second gust) Vasd=103mph; TC DL=6.0psf; BCDL=6.0psf; h=32ft; Cat. II; Exp B; Enclosed; MWFRS (envelope) gable end zone; cantilever left and right exposed; end vertical left and right exposed; Lumber DOL=1.60 plate grip DOL=1.60
- Provide adequate drainage to prevent water ponding.
- This truss has been designed for a 10.0 psf bottom chord live load nonconcurrent with any other live loads.
- \* This truss has been designed for a live load of 20.0psf on the bottom chord in all areas where a rectangle 3-6-0 tall by 2-0-0 wide will fit between the bottom chord and any other members.
- WARNING: Required bearing size at joint(s) 15 greater than input bearing size.
- Provide mechanical connection (by others) of truss to bearing plate capable of withstanding 100 lb uplift at joint(s) except (jt=lb) 15=1073, 8=1074.
- Graphical purlin representation does not depict the size or the orientation of the purlin along the top and/or bottom chord.

**LOAD CASE(S)** Standard

Continued on page 2

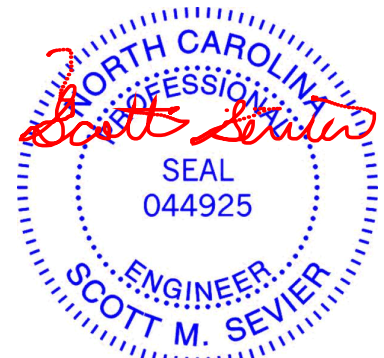

February 15, 2021

**WARNING - Verify design parameters and READ NOTES ON THIS AND INCLUDED MITEK REFERENCE PAGE MII-7473 rev. 5/19/2020 BEFORE USE.**

Design valid for use only with MiTek® connectors. This design is based only upon parameters shown, and is for an individual building component, not a truss system. Before use, the building designer must verify the applicability of design parameters and properly incorporate this design into the overall building design. Bracing indicated is to prevent buckling of individual truss web and/or chord members only. Additional temporary and permanent bracing is always required for stability and to prevent collapse with possible personal injury and property damage. For general guidance regarding the fabrication, storage, delivery, erection and bracing of trusses and truss systems, see ANSITPI Quality Criteria, DSB-89 and BCSI Building Component Safety Information available from Truss Plate Institute, 2670 Crain Highway, Suite 203 Waldorf, MD 20601



818 Soundside Road  
 Edenton, NC 27932

Job MASTER_RT130	Truss L02GR	Truss Type HIP	Qty 1	Ply <b>2</b>	MCKEE; NELSON Job Reference (optional)	I44818035
---------------------	----------------	-------------------	----------	-----------------	---	-----------

Builders FirstSource (Apex, NC), Apex, NC - 27523,

8.240 s Mar 9 2020 MiTek Industries, Inc. Mon Feb 15 14:20:14 2021 Page 2  
ID:f0X\_NZYyOMto?npzE4iXPzyeg2c-3o8bTEAq6ufOZ7BKKGg413oWf7Mxz1YfSu4zaTzksu?

**LOAD CASE(S)** Standard

- 1) Dead + Roof Live (balanced): Lumber Increase=1.15, Plate Increase=1.15  
Uniform Loads (plf)  
Vert: 1-3=-60, 3-5=-60, 5-7=-60, 8-15=-580(F=-560)

**WARNING** - Verify design parameters and READ NOTES ON THIS AND INCLUDED MITEK REFERENCE PAGE MII-7473 rev. 5/19/2020 BEFORE USE.

Design valid for use only with MiTek® connectors. This design is based only upon parameters shown, and is for an individual building component, not a truss system. Before use, the building designer must verify the applicability of design parameters and properly incorporate this design into the overall building design. Bracing indicated is to prevent buckling of individual truss web and/or chord members only. Additional temporary and permanent bracing is always required for stability and to prevent collapse with possible personal injury and property damage. For general guidance regarding the fabrication, storage, delivery, erection and bracing of trusses and truss systems, see **ANSI/TPI1 Quality Criteria, DSB-89 and BCSI Building Component Safety Information** available from Truss Plate Institute, 2670 Crain Highway, Suite 203 Waldorf, MD 20601



818 Soundside Road  
Edenton, NC 27932

Job MASTER_RT130	Truss P06	Truss Type JACK	Qty 1	Ply 1	MCKEE; NELSON	144818036
---------------------	--------------	--------------------	----------	----------	---------------	-----------

Builders FirstSource (Apex, NC),

Apex, NC - 27523,

8.240 s Mar 9 2020 MiTek Industries, Inc. Mon Feb 15 14:20:15 2021 Page 1

ID:f0X\_NZyOMto?npzE4iXPzyeg2c-X\_izgaBTtCnFAHmWuzBJZGLe?XhmiaphYqX7vzksu\_



Scale = 1:14.6

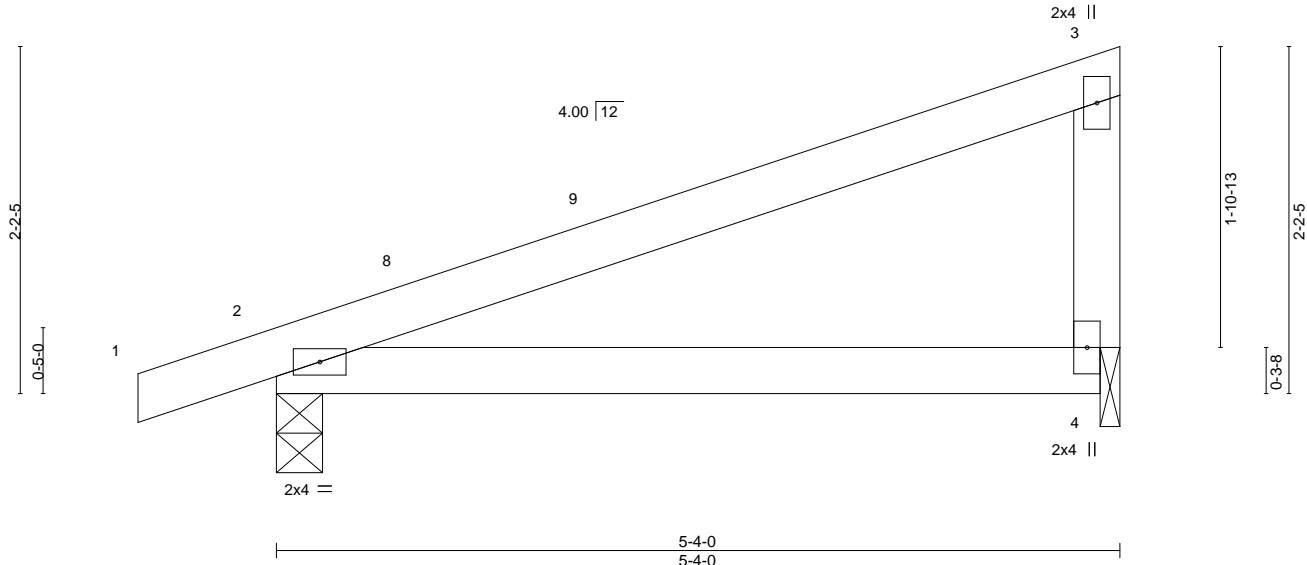

<b>LOADING</b> (psf)	<b>SPACING-</b>	2-0-0	<b>CSI.</b>	<b>DEFL.</b>	in (loc)	l/defl	L/d	<b>PLATES</b>	<b>GRIP</b>
TCLL 20.0	Plate Grip DOL	1.15	TC 0.40	Vert(LL)	-0.03 4-7	>999	360	MT20	244/190
TCDL 10.0	Lumber DOL	1.15	BC 0.30	Vert(CT)	-0.07 4-7	>851	240		
BCLL 0.0 *	Rep Stress Incr	YES	WB 0.00	Horz(CT)	0.01 2	n/a	n/a		
BCDL 10.0	Code IRC2015/TPI2014		Matrix-MP	Wind(LL)	0.04 4-7	>999	240	Weight: 20 lb	FT = 20%

**LUMBER-**  
 TOP CHORD 2x4 SP No.2  
 BOT CHORD 2x4 SP No.2  
 WEBS 2x4 SP No.3

**BRACING-**  
 TOP CHORD Structural wood sheathing directly applied or 5-4-0 oc purlins, except end verticals.  
 BOT CHORD Rigid ceiling directly applied or 10-0-0 oc bracing.

**REACTIONS.** (size) 2=0-3-8, 4=0-1-8  
 Max Horz 2=84(LC 11)  
 Max Uplift 2=72(LC 8), 4=45(LC 12)  
 Max Grav 2=264(LC 1), 4=203(LC 1)

**FORCES.** (lb) - Max. Comp./Max. Ten. - All forces 250 (lb) or less except when shown.

**NOTES-**

- 1) Wind: ASCE 7-10; Vult=130mph (3-second gust) Vasd=103mph; TCDL=6.0psf; BCDL=6.0psf; h=32ft; Cat. II; Exp B; Enclosed; MWFRS (envelope) gable end zone and C-C Exterior(2) -0-10-8 to 2-1-8, Interior(1) 2-1-8 to 5-2-4 zone; cantilever left and right exposed ; end vertical left and right exposed;C-C for members and forces & MWFRS for reactions shown; Lumber DOL=1.60 plate grip DOL=1.60
- 2) This truss has been designed for a 10.0 psf bottom chord live load nonconcurrent with any other live loads.
- 3) \* This truss has been designed for a live load of 20.0psf on the bottom chord in all areas where a rectangle 3-6-0 tall by 2-0-0 wide will fit between the bottom chord and any other members.
- 4) Bearing at joint(s) 4 considers parallel to grain value using ANSI/TPI 1 angle to grain formula. Building designer should verify capacity of bearing surface.
- 5) Provide mechanical connection (by others) of truss to bearing plate at joint(s) 4.
- 6) Provide mechanical connection (by others) of truss to bearing plate capable of withstanding 100 lb uplift at joint(s) 2, 4.



February 15, 2021

Job MASTER_RT130	Truss P06A	Truss Type JACK	Qty 1	Ply 1	MCKEE; NELSON	144818037
---------------------	---------------	--------------------	----------	----------	---------------	-----------

Builders FirstSource (Apex, NC), Apex, NC - 27523,

8.240 s Mar 9 2020 MiTek Industries, Inc. Mon Feb 15 14:20:15 2021 Page 1  
ID:f0X\_NZYyOMto?npzE4iXPyeg2c-X\_izgaBTcNFAHmWuzBJZGLfeXh6iapohYqX7vzksu\_

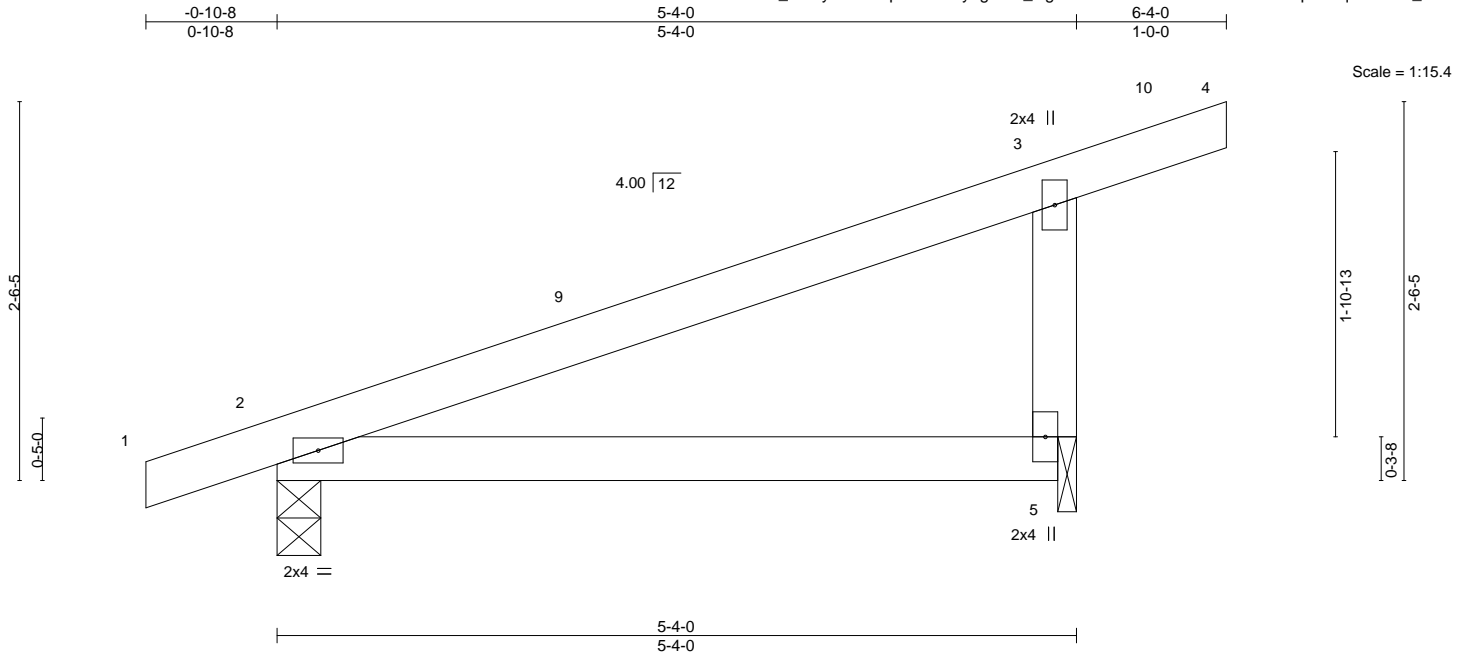

LOADING (psf)	SPACING-	CSI.	DEFL.	in (loc)	I/defl	L/d	PLATES	GRIP
TCLL 20.0	2-0-0	TC 0.36	Vert(LL)	-0.03 5-8	>999	360	MT20	244/190
TCDL 10.0	Plate Grip DOL 1.15	BC 0.28	Vert(CT)	-0.07 5-8	>908	240		
BCLL 0.0 *	Lumber DOL 1.15	WB 0.00	Horz(CT)	0.01 2	n/a	n/a		
BCDL 10.0	Rep Stress Incr YES	Matrix-MP	Wind(LL)	0.03 5-8	>999	240		
	Code IRC2015/TPI2014						Weight: 22 lb	FT = 20%

**LUMBER-**  
TOP CHORD 2x4 SP No.2  
BOT CHORD 2x4 SP No.2  
WEBS 2x4 SP No.3

**BRACING-**  
TOP CHORD Structural wood sheathing directly applied or 5-4-0 oc purlins, except end verticals.  
BOT CHORD Rigid ceiling directly applied or 10-0-0 oc bracing.

**REACTIONS.** (size) 2=0-3-8, 5=0-1-8  
Max Horz 2=98(LC 9)  
Max Uplift 2=64(LC 8), 5=75(LC 8)  
Max Grav 2=257(LC 1), 5=279(LC 1)

**FORCES.** (lb) - Max. Comp./Max. Ten. - All forces 250 (lb) or less except when shown.

**NOTES-**

- 1) Wind: ASCE 7-10; Vult=130mph (3-second gust) Vasd=103mph; TCDL=6.0psf; BCDL=6.0psf; h=32ft; Cat. II; Exp B; Enclosed; MWFRS (envelope) gable end zone and C-C Exterior(2) -0-10-8 to 2-1-8, Interior(1) 2-1-8 to 6-4-0 zone; cantilever left and right exposed; end vertical left and right exposed; C-C for members and forces & MWFRS for reactions shown; Lumber DOL=1.60 plate grip DOL=1.60
- 2) This truss has been designed for a 10.0 psf bottom chord live load nonconcurrent with any other live loads.
- 3) \* This truss has been designed for a live load of 20.0psf on the bottom chord in all areas where a rectangle 3-6-0 tall by 2-0-0 wide will fit between the bottom chord and any other members.
- 4) Bearing at joint(s) 5 considers parallel to grain value using ANSI/TPI 1 angle to grain formula. Building designer should verify capacity of bearing surface.
- 5) Provide mechanical connection (by others) of truss to bearing plate at joint(s) 4.
- 6) Provide mechanical connection (by others) of truss to bearing plate capable of withstanding 100 lb uplift at joint(s) 2, 5.



February 15, 2021

**WARNING - Verify design parameters and READ NOTES ON THIS AND INCLUDED MITEK REFERENCE PAGE MII-7473 rev. 5/19/2020 BEFORE USE.**

Design valid for use only with MiTek® connectors. This design is based only upon parameters shown, and is for an individual building component, not a truss system. Before use, the building designer must verify the applicability of design parameters and properly incorporate this design into the overall building design. Bracing indicated is to prevent buckling of individual truss web and/or chord members only. Additional temporary and permanent bracing is always required for stability and to prevent collapse with possible personal injury and property damage. For general guidance regarding the fabrication, storage, delivery, erection and bracing of trusses and truss systems, see **ANSI/TPI1 Quality Criteria, DSB-89 and BCSI Building Component Safety Information** available from Truss Plate Institute, 2670 Crain Highway, Suite 203 Waldorf, MD 20601



818 Soundside Road  
Edenton, NC 27932

Job MASTER_RT130	Truss P07	Truss Type JACK	Qty 1	Ply 1	MCKEE; NELSON	144818038
---------------------	--------------	--------------------	----------	----------	---------------	-----------

Builders FirstSource (Apex, NC),

Apex, NC - 27523,

8.240 s Mar 9 2020 MiTek Industries, Inc. Mon Feb 15 14:20:16 2021 Page 1

ID:f0X\_NZYyOMto?npzE4iXpzyeg2c-?BGLuwC5eVv6oRLjShiY6Uuplx0\_R03xwCZ4eMzkstz



Scale = 1:14.6

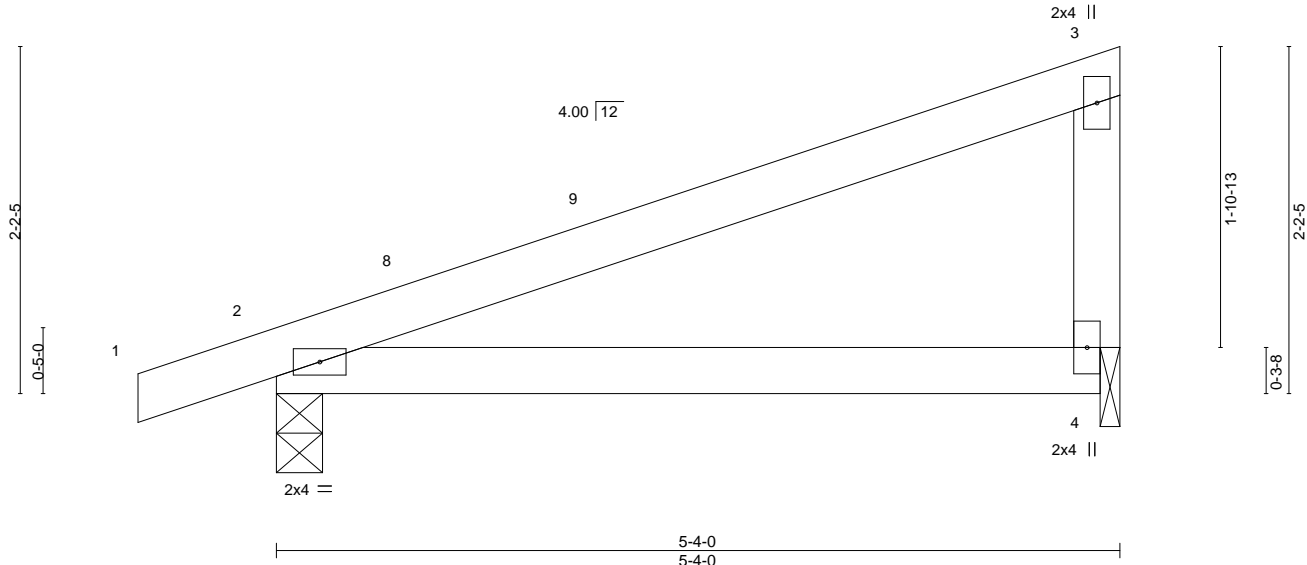

<b>LOADING</b> (psf)	<b>SPACING-</b>	2-0-0	<b>CSI.</b>	<b>DEFL.</b>	in (loc)	l/defl	L/d	<b>PLATES</b>	<b>GRIP</b>
TCLL 20.0	Plate Grip DOL	1.15	TC 0.40	Vert(LL)	-0.03 4-7	>999	360	MT20	244/190
TCDL 10.0	Lumber DOL	1.15	BC 0.30	Vert(CT)	-0.07 4-7	>851	240		
BCLL 0.0 *	Rep Stress Incr	YES	WB 0.00	Horz(CT)	0.01 2	n/a	n/a		
BCDL 10.0	Code IRC2015/TPI2014		Matrix-MP	Wind(LL)	0.04 4-7	>999	240	Weight: 20 lb	FT = 20%

**LUMBER-**  
 TOP CHORD 2x4 SP No.2  
 BOT CHORD 2x4 SP No.2  
 WEBS 2x4 SP No.3

**BRACING-**  
 TOP CHORD Structural wood sheathing directly applied or 5-4-0 oc purlins, except end verticals.  
 BOT CHORD Rigid ceiling directly applied or 10-0-0 oc bracing.

**REACTIONS.** (size) 2=0-3-8, 4=0-1-8  
 Max Horz 2=84(LC 11)  
 Max Uplift 2=72(LC 8), 4=45(LC 12)  
 Max Grav 2=264(LC 1), 4=203(LC 1)

**FORCES.** (lb) - Max. Comp./Max. Ten. - All forces 250 (lb) or less except when shown.

**NOTES-**

- 1) Wind: ASCE 7-10; Vult=130mph (3-second gust) Vasd=103mph; TCDL=6.0psf; BCDL=6.0psf; h=32ft; Cat. II; Exp B; Enclosed; MWFRS (envelope) gable end zone and C-C Exterior(2) -0-10-8 to 2-1-8, Interior(1) 2-1-8 to 5-2-4 zone; cantilever left and right exposed ; end vertical left and right exposed;C-C for members and forces & MWFRS for reactions shown; Lumber DOL=1.60 plate grip DOL=1.60
- 2) This truss has been designed for a 10.0 psf bottom chord live load nonconcurrent with any other live loads.
- 3) \* This truss has been designed for a live load of 20.0psf on the bottom chord in all areas where a rectangle 3-6-0 tall by 2-0-0 wide will fit between the bottom chord and any other members.
- 4) Bearing at joint(s) 4 considers parallel to grain value using ANSI/TPI 1 angle to grain formula. Building designer should verify capacity of bearing surface.
- 5) Provide mechanical connection (by others) of truss to bearing plate at joint(s) 4.
- 6) Provide mechanical connection (by others) of truss to bearing plate capable of withstanding 100 lb uplift at joint(s) 2, 4.

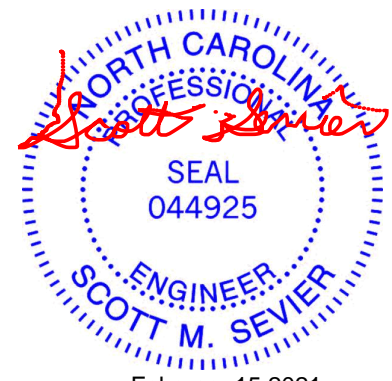

February 15, 2021

Job MASTER_RT130	Truss P08	Truss Type MONO HIP	Qty 1	Ply 1	MCKEE; NELSON	144818039
---------------------	--------------	------------------------	----------	----------	---------------	-----------

Builders FirstSource (Apex, NC), Apex, NC - 27523,

8.240 s Mar 9 2020 MiTek Industries, Inc. Mon Feb 15 14:20:17 2021 Page 1  
ID:f0X\_NZYyOMto?npzE4iXPzyeg2c-TNqj5FCjPp1zQbww0OEohQ\_KNRATJ59sJdAozksty

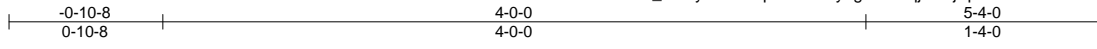

Scale = 1:13.1

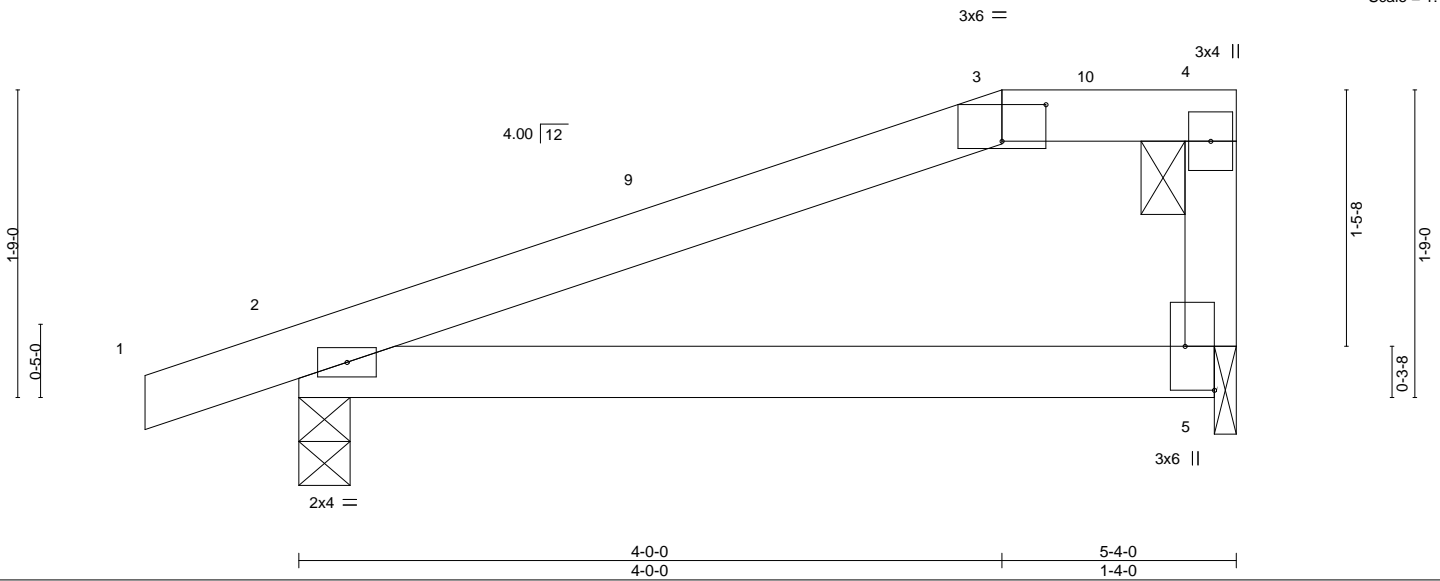

Plate Offsets (X, Y)--	[3:0-3-0,0-2-8], [5:Edge,0-2-0]
------------------------	---------------------------------

LOADING (psf)	SPACING-	2-0-0	CSI.	DEFL.	in (loc)	l/defl	L/d	PLATES	GRIP
TCLL 20.0	Plate Grip DOL	1.15	TC 0.43	Vert(LL)	-0.01	5-8	>999	MT20	244/190
TCDL 10.0	Lumber DOL	1.15	BC 0.22	Vert(CT)	-0.03	5-8	>999		
BCLL 0.0 *	Rep Stress Incr	YES	WB 0.00	Horz(CT)	0.00	2	n/a		
BCDL 10.0	Code IRC2015/TPI2014		Matrix-MR	Wind(LL)	0.01	5-8	>999		
								Weight: 19 lb	FT = 20%

LUMBER-	BRACING-
TOP CHORD 2x4 SP No.2	TOP CHORD Structural wood sheathing directly applied or 5-4-0 oc purlins, except end verticals, and 2-0-0 oc purlins: 3-4.
BOT CHORD 2x4 SP No.2	BOT CHORD Rigid ceiling directly applied or 10-0-0 oc bracing.
WEBS 2x4 SP No.3	

**REACTIONS.** (size) 2=0-3-8, 5=0-1-8  
 Max Horz 2=67(LC 11)  
 Max Uplift 2=-75(LC 8), 5=-41(LC 8)  
 Max Grav 2=264(LC 1), 5=203(LC 1)

**FORCES.** (lb) - Max. Comp./Max. Ten. - All forces 250 (lb) or less except when shown.

- NOTES-**
- Unbalanced roof live loads have been considered for this design.
  - Wind: ASCE 7-10; Vult=130mph (3-second gust) Vasd=103mph; TC DL=6.0psf; BCDL=6.0psf; h=32ft; Cat. II; Exp B; Enclosed; MWFRS (envelope) gable end zone and C-C Exterior(2) -0-10-8 to 2-1-8, Interior(1) 2-1-8 to 4-0-0, Exterior(2) 4-0-0 to 5-2-4 zone; cantilever left and right exposed; end vertical left and right exposed; C-C for members and forces & MWFRS for reactions shown; Lumber DOL=1.60 plate grip DOL=1.60
  - Provide adequate drainage to prevent water ponding.
  - This truss has been designed for a 10.0 psf bottom chord live load nonconcurrent with any other live loads.
  - \* This truss has been designed for a live load of 20.0psf on the bottom chord in all areas where a rectangle 3-6-0 tall by 2-0-0 wide will fit between the bottom chord and any other members.
  - Bearing at joint(s) 5 considers parallel to grain value using ANSI/TPI 1 angle to grain formula. Building designer should verify capacity of bearing surface.
  - Provide mechanical connection (by others) of truss to bearing plate at joint(s) 5.
  - Provide mechanical connection (by others) of truss to bearing plate capable of withstanding 100 lb uplift at joint(s) 2, 5.
  - Graphical purlin representation does not depict the size or the orientation of the purlin along the top and/or bottom chord.



February 15, 2021



Job MASTER_RT130	Truss P09	Truss Type MONO HIP	Qty 1	Ply 1	MCKEE; NELSON	144818040
---------------------	--------------	------------------------	----------	----------	---------------	-----------

Builders FirstSource (Apex, NC), Apex, NC - 27523,

8.240 s Mar 9 2020 MiTek Industries, Inc. Mon Feb 15 14:20:17 2021 Page 1  
ID:f0X\_NZYyOMto?npzE4iXPzyeg2c-TNqj5FCjPp1zQbvv0OEoehQ1NKGuATk59sJdAozkzy

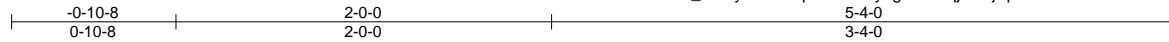

Scale = 1:12.3

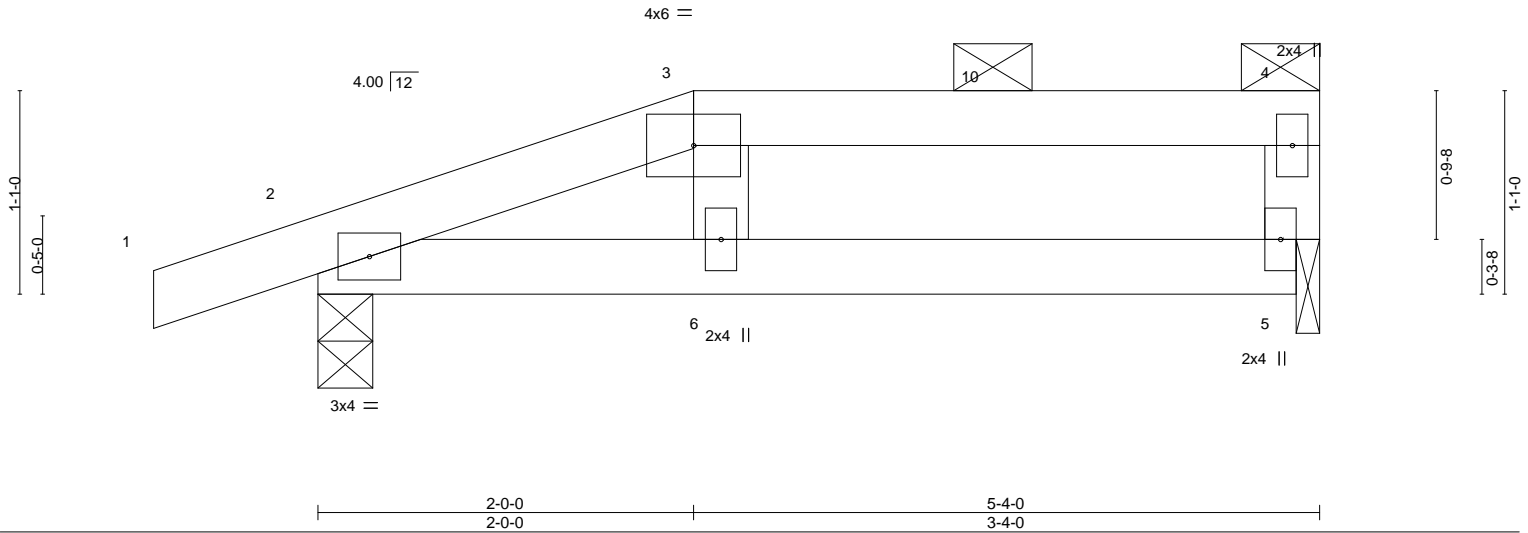

<b>LOADING</b> (psf)	<b>SPACING-</b>	2-0-0	<b>CSI.</b>	<b>DEFL.</b>	in (loc)	l/defl	L/d	<b>PLATES</b>	<b>GRIP</b>
TCLL 20.0	Plate Grip DOL	1.15	TC 0.21	Vert(LL)	-0.05 5-6	>999	360	MT20	244/190
TCDL 10.0	Lumber DOL	1.15	BC 0.64	Vert(CT)	-0.12 5-6	>517	240		
BCLL 0.0 *	Rep Stress Incr	NO	WB 0.04	Horz(CT)	0.01 2	n/a	n/a		
BCDL 10.0	Code IRC2015/TPI2014		Matrix-MP	Wind(LL)	0.05 5-6	>999	240	Weight: 19 lb	FT = 20%

**LUMBER-**  
TOP CHORD 2x4 SP No.2  
BOT CHORD 2x4 SP No.2  
WEBS 2x4 SP No.3

**BRACING-**  
TOP CHORD Structural wood sheathing directly applied or 5-4-0 oc purlins, except end verticals, and 2-0-0 oc purlins: 3-4.  
BOT CHORD Rigid ceiling directly applied or 10-0-0 oc bracing.

**REACTIONS.** (size) 2=0-3-8, 5=0-1-8  
Max Horz 2=38(LC 7)  
Max Uplift 2=77(LC 4), 5=38(LC 4)  
Max Grav 2=264(LC 1), 5=203(LC 1)

**FORCES.** (lb) - Max. Comp./Max. Ten. - All forces 250 (lb) or less except when shown.

**NOTES-**

- 1) Unbalanced roof live loads have been considered for this design.
- 2) Wind: ASCE 7-10; Vult=130mph (3-second gust) Vasd=103mph; TCDL=6.0psf; BCDL=6.0psf; h=32ft; Cat. II; Exp B; Enclosed; MWFRS (envelope) gable end zone; cantilever left and right exposed; end vertical left and right exposed; Lumber DOL=1.60 plate grip DOL=1.60
- 3) Provide adequate drainage to prevent water ponding.
- 4) This truss has been designed for a 10.0 psf bottom chord live load nonconcurrent with any other live loads.
- 5) \* This truss has been designed for a live load of 20.0psf on the bottom chord in all areas where a rectangle 3-6-0 tall by 2-0-0 wide will fit between the bottom chord and any other members.
- 6) Bearing at joint(s) 5 considers parallel to grain value using ANSI/TPI 1 angle to grain formula. Building designer should verify capacity of bearing surface.
- 7) Provide mechanical connection (by others) of truss to bearing plate at joint(s) 5.
- 8) Provide mechanical connection (by others) of truss to bearing plate capable of withstanding 100 lb uplift at joint(s) 2, 5.
- 9) Graphical purlin representation does not depict the size or the orientation of the purlin along the top and/or bottom chord.



February 15, 2021

**WARNING - Verify design parameters and READ NOTES ON THIS AND INCLUDED MITEK REFERENCE PAGE MII-7473 rev. 5/19/2020 BEFORE USE.**  
Design valid for use only with MiTek® connectors. This design is based only upon parameters shown, and is for an individual building component, not a truss system. Before use, the building designer must verify the applicability of design parameters and properly incorporate this design into the overall building design. Bracing indicated is to prevent buckling of individual truss web and/or chord members only. Additional temporary and permanent bracing is always required for stability and to prevent collapse with possible personal injury and property damage. For general guidance regarding the fabrication, storage, delivery, erection and bracing of trusses and truss systems, see **ANSI/TPI1 Quality Criteria, DSB-89 and BCSI Building Component Safety Information** available from Truss Plate Institute, 2670 Crain Highway, Suite 203 Waldorf, MD 20601

ENGINEERING BY  
**TRENCO**  
A MiTek Affiliate  
818 Soundside Road  
Edenton, NC 27932

Job MASTER_RT130	Truss P10	Truss Type JACK	Qty 1	Ply 1	MCKEE; NELSON	144818041
---------------------	--------------	--------------------	----------	----------	---------------	-----------

Builders FirstSource (Apex, NC),

Apex, NC - 27523,

8.240 s Mar 9 2020 MiTek Industries, Inc. Mon Feb 15 14:20:18 2021 Page 1  
ID:f0X\_NZYyOMto?npzE4iXPzyeg2c-xZO6JbDLA79q1kV5Z6l1BvzFekmivwZENW2BiEzkstx

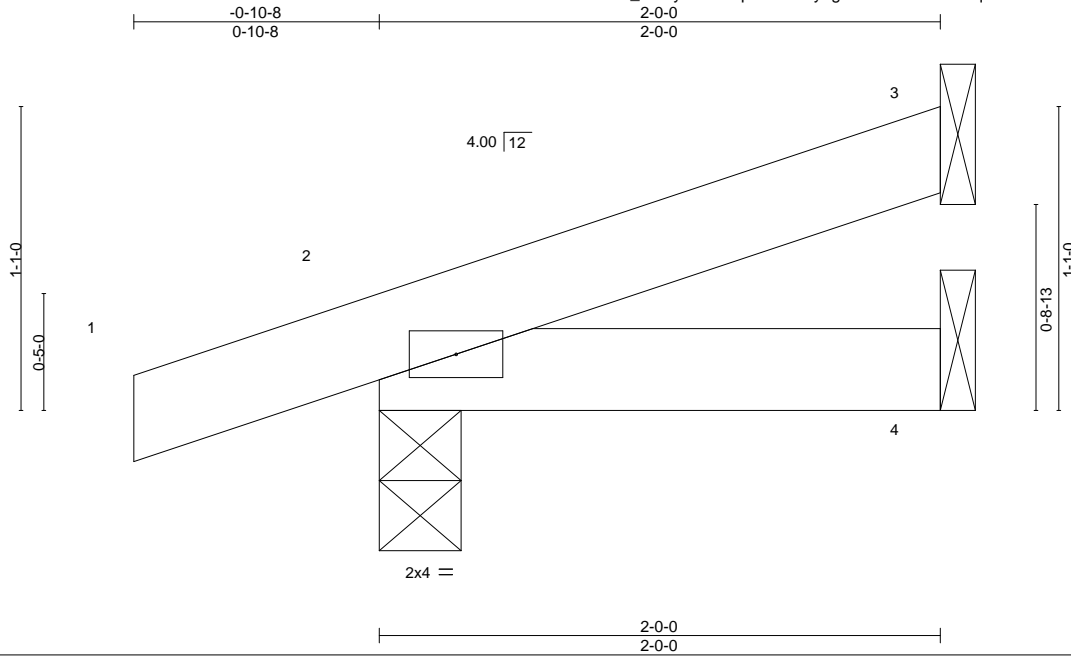

LOADING (psf)	SPACING-	CSL.	DEFL.	in (loc)	l/defl	L/d	PLATES	GRIP
TCLL 20.0	2-0-0	TC 0.05	Vert(LL)	-0.00	7	>999	MT20	244/190
TCDL 10.0	Plate Grip DOL 1.15	BC 0.03	Vert(CT)	-0.00	7	>999		
BCLL 0.0 *	Lumber DOL 1.15	WB 0.00	Horz(CT)	0.00	2	n/a		
BCDL 10.0	Rep Stress Incr YES	Matrix-MP	Wind(LL)	0.00	7	>999		
	Code IRC2015/TPI2014						Weight: 8 lb	FT = 20%

LUMBER-	BRACING-
TOP CHORD 2x4 SP No.2	TOP CHORD Structural wood sheathing directly applied or 2-0-0 oc purlins.
BOT CHORD 2x4 SP No.2	BOT CHORD Rigid ceiling directly applied or 10-0-0 oc bracing.

**REACTIONS.** (size) 3=Mechanical, 2=0-3-8, 4=Mechanical  
 Max Horz 2=41(LC 8)  
 Max Uplift 3=-21(LC 12), 2=-53(LC 8)  
 Max Grav 3=45(LC 1), 2=144(LC 1), 4=34(LC 3)

**FORCES.** (lb) - Max. Comp./Max. Ten. - All forces 250 (lb) or less except when shown.

- NOTES-**
- 1) Wind: ASCE 7-10: Vult=130mph (3-second gust) Vasd=103mph; TCDL=6.0psf; BCDL=6.0psf; h=32ft; Cat. II; Exp B; Enclosed; MWFRS (envelope) gable end zone and C-C Exterior(2) zone; cantilever left and right exposed; end vertical left and right exposed; C-C for members and forces & MWFRS for reactions shown; Lumber DOL=1.60 plate grip DOL=1.60
  - 2) This truss has been designed for a 10.0 psf bottom chord live load nonconcurrent with any other live loads.
  - 3) \* This truss has been designed for a live load of 20.0psf on the bottom chord in all areas where a rectangle 3-6-0 tall by 2-0-0 wide will fit between the bottom chord and any other members.
  - 4) Refer to girder(s) for truss connections.
  - 5) Provide mechanical connection (by others) of truss to bearing plate capable of withstanding 100 lb uplift at joint(s) 3, 2.



February 15, 2021

Job MASTER_RT130	Truss SP01G	Truss Type GABLE	Qty 1	Ply 1	MCKEE; NELSON	144818042
---------------------	----------------	---------------------	----------	----------	---------------	-----------

Builders FirstSource (Apex, NC), Apex, NC - 27523,

8.240 s Mar 9 2020 MiTek Industries, Inc. Mon Feb 15 14:20:20 2021 Page 1

ID:f0X\_NZYyOMto?npzE4iXPzyeg2c-tyVskHFbhkPYH2fUhxNvGK2aeYSDNqdXrqXln7zkstv

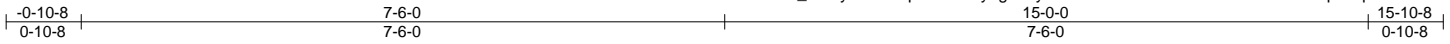

Scale = 1:26.9

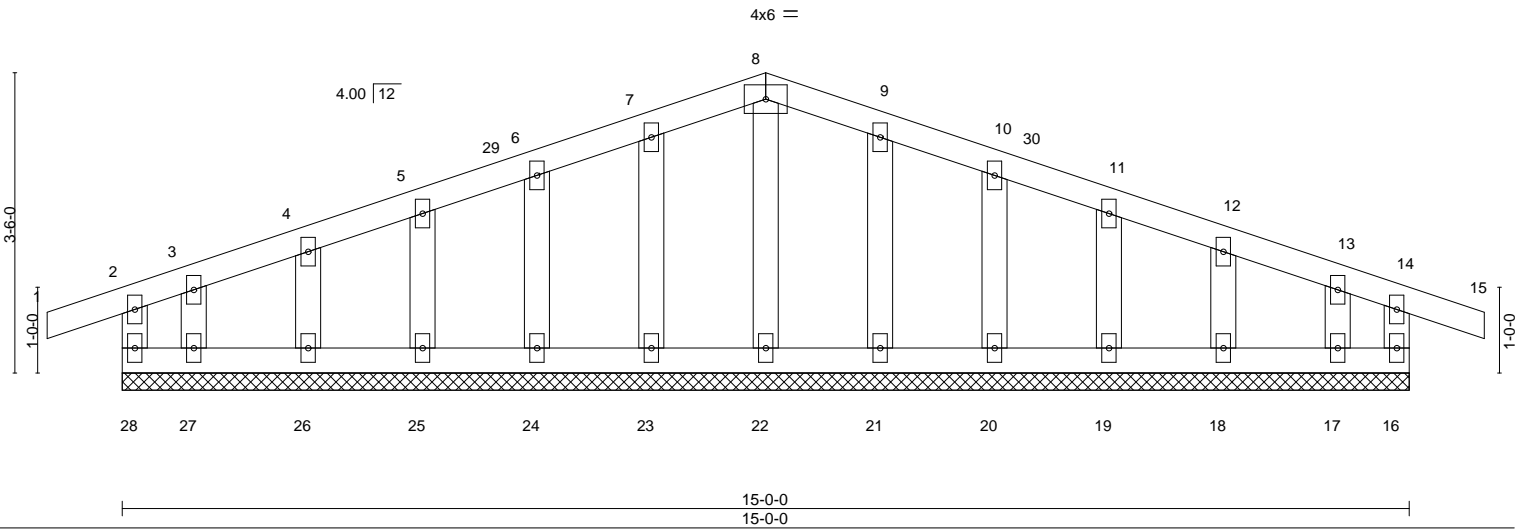

<b>LOADING</b> (psf)	<b>SPACING-</b>	2-0-0	<b>CSI.</b>	<b>DEFL.</b>	in (loc)	l/defl	L/d	<b>PLATES</b>	<b>GRIP</b>
TCLL 20.0	Plate Grip DOL	1.15	TC 0.08	Vert(LL)	-0.00	15	n/r	MT20	244/190
TCDL 10.0	Lumber DOL	1.15	BC 0.03	Vert(CT)	-0.00	15	n/r		
BCLL 0.0 *	Rep Stress Incr	NO	WB 0.03	Horz(CT)	0.00	16	n/a		
BCDL 10.0	Code IRC2015/TPI2014		Matrix-R						
								Weight: 79 lb	FT = 20%

**LUMBER-**  
TOP CHORD 2x4 SP No.2  
BOT CHORD 2x4 SP No.2  
WEBS 2x4 SP No.3  
OTHERS 2x4 SP No.3

**BRACING-**  
TOP CHORD Structural wood sheathing directly applied or 6-0-0 oc purlins, except end verticals.  
BOT CHORD Rigid ceiling directly applied or 6-0-0 oc bracing.

**REACTIONS.** All bearings 15-0-0.  
(lb) - Max Horz 28=23(LC 12)  
Max Uplift All uplift 100 lb or less at joint(s) 28, 16, 23, 24, 25, 26, 27, 21, 20, 19, 18, 17  
Max Grav All reactions 250 lb or less at joint(s) 28, 16, 22, 23, 24, 25, 26, 27, 21, 20, 19, 18, 17

**FORCES.** (lb) - Max. Comp./Max. Ten. - All forces 250 (lb) or less except when shown.

**NOTES-**

- 1) Unbalanced roof live loads have been considered for this design.
- 2) Wind: ASCE 7-10; Vult=130mph (3-second gust) Vasd=103mph; TC DL=6.0psf; BCDL=6.0psf; h=32ft; Cat. II; Exp B; Enclosed; MWFRS (envelope) gable end zone and C-C Corner(3) -0-10-8 to 2-2-0, Exterior(2) 2-2-0 to 7-6-0, Corner(3) 7-6-0 to 10-6-0, Exterior(2) 10-6-0 to 15-10-8 zone; cantilever left and right exposed ; end vertical left and right exposed;C-C for members and forces & MWFRS for reactions shown; Lumber DOL=1.60 plate grip DOL=1.60
- 3) Truss designed for wind loads in the plane of the truss only. For studs exposed to wind (normal to the face), see Standard Industry Gable End Details as applicable, or consult qualified building designer as per ANSI/TPI 1.
- 4) All plates are 2x4 MT20 unless otherwise indicated.
- 5) Gable requires continuous bottom chord bearing.
- 6) Truss to be fully sheathed from one face or securely braced against lateral movement (i.e. diagonal web).
- 7) Gable studs spaced at 1-4-0 oc.
- 8) This truss has been designed for a 10.0 psf bottom chord live load nonconcurrent with any other live loads.
- 9) \* This truss has been designed for a live load of 20.0psf on the bottom chord in all areas where a rectangle 3-6-0 tall by 2-0-0 wide will fit between the bottom chord and any other members.
- 10) Provide mechanical connection (by others) of truss to bearing plate capable of withstanding 100 lb uplift at joint(s) 28, 16, 23, 24, 25, 26, 27, 21, 20, 19, 18, 17.



February 15, 2021

**WARNING - Verify design parameters and READ NOTES ON THIS AND INCLUDED MITEK REFERENCE PAGE MII-7473 rev. 5/19/2020 BEFORE USE.**

Design valid for use only with MiTek® connectors. This design is based only upon parameters shown, and is for an individual building component, not a truss system. Before use, the building designer must verify the applicability of design parameters and properly incorporate this design into the overall building design. Bracing indicated is to prevent buckling of individual truss web and/or chord members only. Additional temporary and permanent bracing is always required for stability and to prevent collapse with possible personal injury and property damage. For general guidance regarding the fabrication, storage, delivery, erection and bracing of trusses and truss systems, see

**ANSI/TPI1 Quality Criteria, DSB-89 and BCSI Building Component**

**Safety Information** available from Truss Plate Institute, 2670 Crain Highway, Suite 203 Waldorf, MD 20601



818 Soundside Road  
Edenton, NC 27932

Job MASTER_RT130	Truss SP02	Truss Type COMMON	Qty 1	Ply 1	MCKEE; NELSON	144818043
---------------------	---------------	----------------------	----------	----------	---------------	-----------

Builders FirstSource (Apex, NC), Apex, NC - 27523, 8.240 s Mar 9 2020 MiTek Industries, Inc. Mon Feb 15 14:20:21 2021 Page 1

ID:f0X\_NZYyOMto?npzE4iXPzyeg2c-M83ExdGDS2XPuCEgFEIkpXbYKyhZ6Geh4UHrJZzkstu

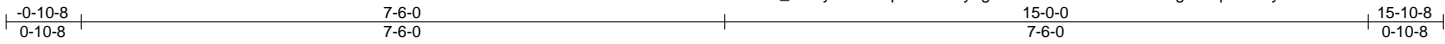

Scale = 1:26.9

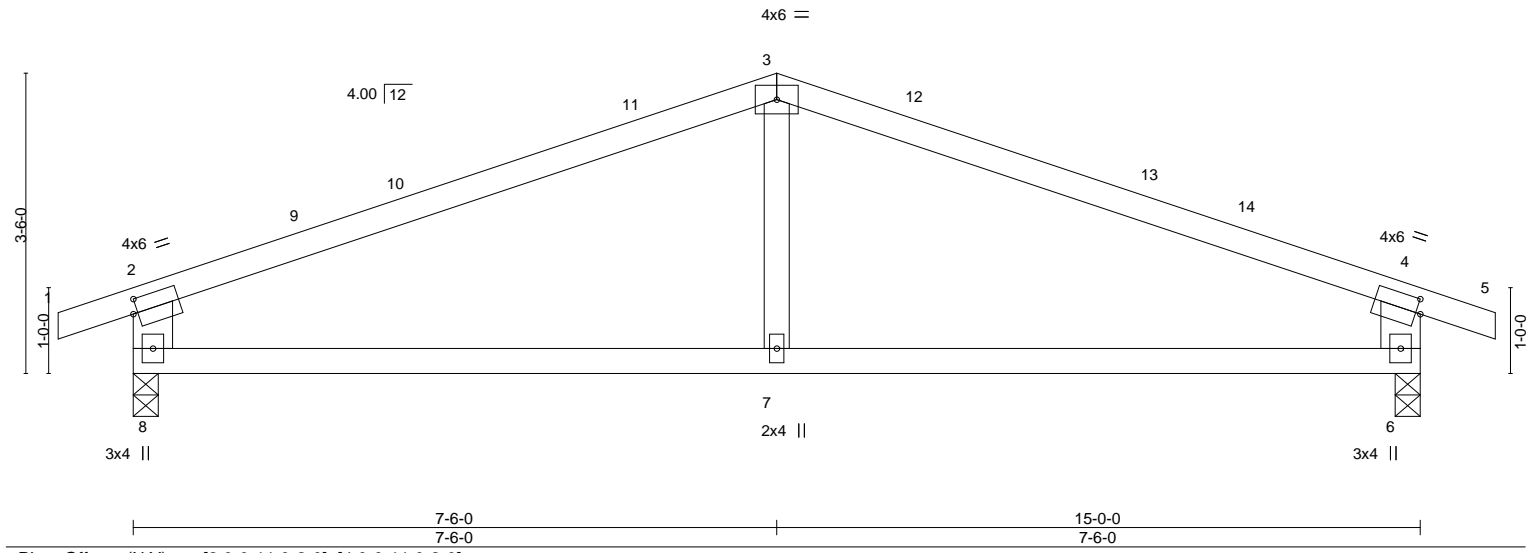

Plate Offsets (X, Y)--	[2:0-0-11,0-2-0], [4:0-0-11,0-2-0]
------------------------	------------------------------------

LOADING (psf)	SPACING-	CSI.	DEFL.	PLATES	GRIP
TCLL 20.0	2-0-0	TC 0.92	in (loc) l/defl L/d	MT20	244/190
TCDL 10.0	Plate Grip DOL 1.15	BC 0.47	Vert(LL) -0.08 6-7 >999 360		
BCLL 0.0 *	Lumber DOL 1.15	WB 0.11	Vert(CT) -0.18 6-7 >953 240		
BCDL 10.0	Rep Stress Incr YES	Matrix-MR	Horz(CT) 0.02 6 n/a n/a		
	Code IRC2015/TPI2014		Wind(LL) 0.03 7-8 >999 240	Weight: 56 lb	FT = 20%

LUMBER-	BRACING-
TOP CHORD 2x4 SP No.2	TOP CHORD Structural wood sheathing directly applied or 2-2-0 oc purlins, except end verticals.
BOT CHORD 2x4 SP No.2	BOT CHORD Rigid ceiling directly applied or 10-0-0 oc bracing.
WEBS 2x6 SP No.2 *Except* 3-7: 2x4 SP No.3	

**REACTIONS.** (size) 8=0-3-8, 6=0-3-8  
 Max Horz 8=34(LC 16)  
 Max Uplift 8=-131(LC 8), 6=-131(LC 9)  
 Max Grav 8=648(LC 1), 6=648(LC 1)

**FORCES.** (lb) - Max. Comp./Max. Ten. - All forces 250 (lb) or less except when shown.  
 TOP CHORD 2-3=-806/159, 3-4=-806/159, 2-8=-562/208, 4-6=-562/208  
 BOT CHORD 7-8=-80/685, 6-7=-80/685  
 WEBS 3-7=0/280

- NOTES-**
- 1) Unbalanced roof live loads have been considered for this design.
  - 2) Wind: ASCE 7-10; Vult=130mph (3-second gust) Vasd=103mph; TCDL=6.0psf; BCDL=6.0psf; h=32ft; Cat. II; Exp B; Enclosed; MWFRS (envelope) gable end zone and C-C Exterior(2) -0-10-8 to 2-1-8, Interior(1) 2-1-8 to 7-6-0, Exterior(2) 7-6-0 to 11-8-15, Interior(1) 11-8-15 to 15-10-8 zone; cantilever left and right exposed ; end vertical left and right exposed;C-C for members and forces & MWFRS for reactions shown; Lumber DOL=1.60 plate grip DOL=1.60
  - 3) This truss has been designed for a 10.0 psf bottom chord live load nonconcurrent with any other live loads.
  - 4) \* This truss has been designed for a live load of 20.0psf on the bottom chord in all areas where a rectangle 3-6-0 tall by 2-0-0 wide will fit between the bottom chord and any other members.
  - 5) Provide mechanical connection (by others) of truss to bearing plate capable of withstanding 100 lb uplift at joint(s) except (jt=lb) 8=131, 6=131.



February 15, 2021

Job	Truss	Truss Type	Qty	Ply	MCKEE; NELSON	144818044
MASTER_RT130	SP03	COMMON	1	1		

Builders FirstSource (Apex, NC), Apex, NC - 27523, 8.240 s Mar 9 2020 MiTek Industries, Inc. Mon Feb 15 14:20:23 2021 Page 1

ID:f0X\_NZYyOMto?npzE4iXPzyeg2c-IXB\_MJHU\_fn78WN3MfKCuygxbIM1aBOzXomyOSzksts

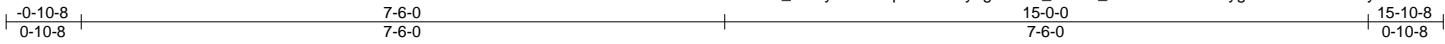

Scale = 1:26.9

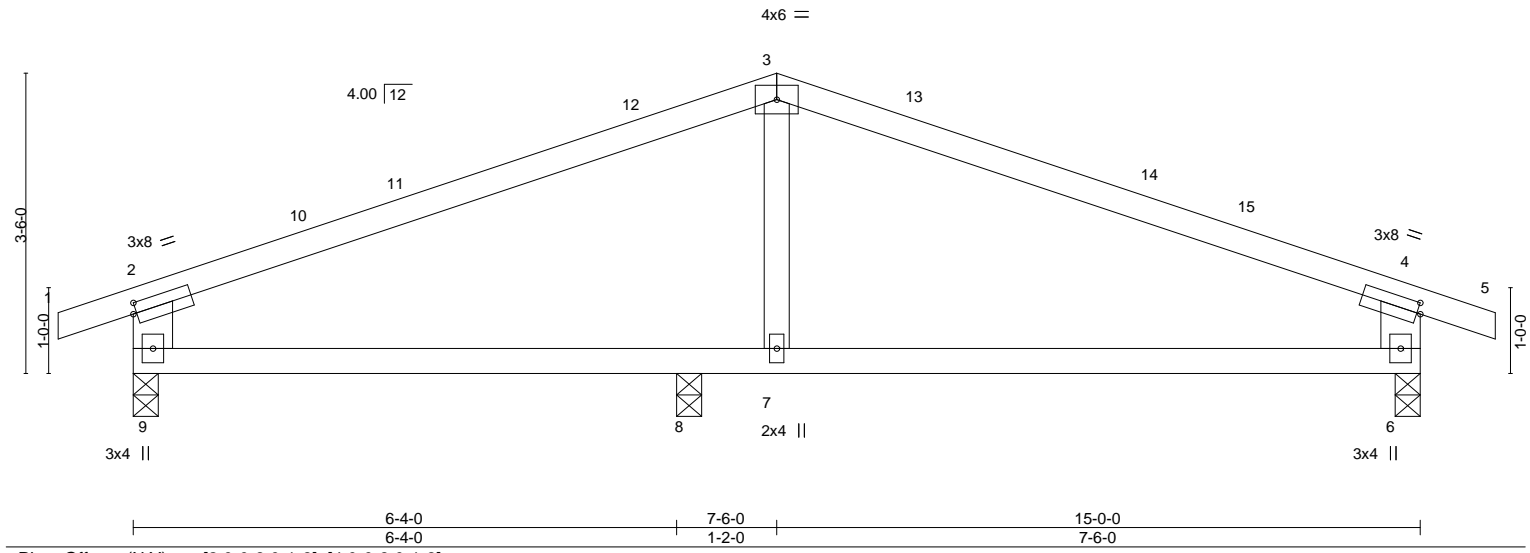

Plate Offsets (X,Y)-- [2:0-0-8,0-1-8], [4:0-0-8,0-1-8]

LOADING (psf)	SPACING-	CSI.	DEFL.	PLATES	GRIP
TCLL 20.0	2-0-0	TC 0.74	in (loc) l/defl L/d	MT20	244/190
TCDL 10.0	Plate Grip DOL 1.15	BC 0.47	Vert(LL) -0.09 6-7 >999 360		
BCLL 0.0 *	Lumber DOL 1.15	WB 0.03	Vert(CT) -0.19 6-7 >529 240		
BCDL 10.0	Rep Stress Incr YES	Matrix-MR	Horz(CT) 0.01 6 n/a n/a		
	Code IRC2015/TPI2014		Wind(LL) 0.03 6-7 >999 240	Weight: 56 lb	FT = 20%

LUMBER-	BRACING-
TOP CHORD 2x4 SP No.2	TOP CHORD Structural wood sheathing directly applied or 6-0-0 oc purlins, except end verticals.
BOT CHORD 2x4 SP No.2	BOT CHORD Rigid ceiling directly applied or 10-0-0 oc bracing.
WEBS 2x6 SP No.2 *Except* 3-7: 2x4 SP No.3	

**REACTIONS.** (size) 9=0-3-8, 6=0-3-8, 8=0-3-8  
 Max Horz 9=34(LC 16)  
 Max Uplift 9=155(LC 8), 6=157(LC 9)  
 Max Grav 9=513(LC 1), 6=546(LC 1), 8=258(LC 3)

**FORCES.** (lb) - Max. Comp./Max. Ten. - All forces 250 (lb) or less except when shown.  
 TOP CHORD 2-3=-560/210, 3-4=-558/196, 2-9=-468/228, 4-6=-463/222  
 BOT CHORD 8-9=-113/456, 7-8=-113/456, 6-7=-113/456

- NOTES-**
- Unbalanced roof live loads have been considered for this design.
  - Wind: ASCE 7-10; Vult=130mph (3-second gust) Vasd=103mph; TCDL=6.0psf; BCDL=6.0psf; h=32ft; Cat. II; Exp B; Enclosed; MWFRS (envelope) gable end zone and C-C Exterior(2) -0-10-8 to 2-1-8, Interior(1) 2-1-8 to 7-6-0, Exterior(2) 7-6-0 to 11-8-15, Interior(1) 11-8-15 to 15-10-8 zone; cantilever left and right exposed; end vertical left and right exposed; C-C for members and forces & MWFRS for reactions shown; Lumber DOL=1.60 plate grip DOL=1.60
  - This truss has been designed for a 10.0 psf bottom chord live load nonconcurrent with any other live loads.
  - \* This truss has been designed for a live load of 20.0psf on the bottom chord in all areas where a rectangle 3-6-0 tall by 2-0-0 wide will fit between the bottom chord and any other members.
  - Provide mechanical connection (by others) of truss to bearing plate capable of withstanding 100 lb uplift at joint(s) except (jt=lb) 9=155, 6=157.



February 15, 2021

Job MASTER_RT130	Truss V10	Truss Type VALLEY	Qty 1	Ply 1	MCKEE; NELSON	144818045
---------------------	--------------	----------------------	----------	----------	---------------	-----------

Builders FirstSource (Apex, NC),

Apex, NC - 27523,

8.240 s Mar 9 2020 MiTek Industries, Inc. Mon Feb 15 14:20:25 2021 Page 1

ID:f0X\_NZYyOMto?npzE4iXPzyeg2c-EwJln\_JkWG1qNpXRU4NgzNmNPZ67235G\_6F2SKzkstq

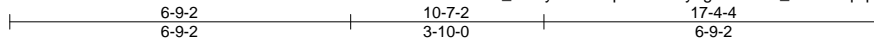

Scale = 1:45.7

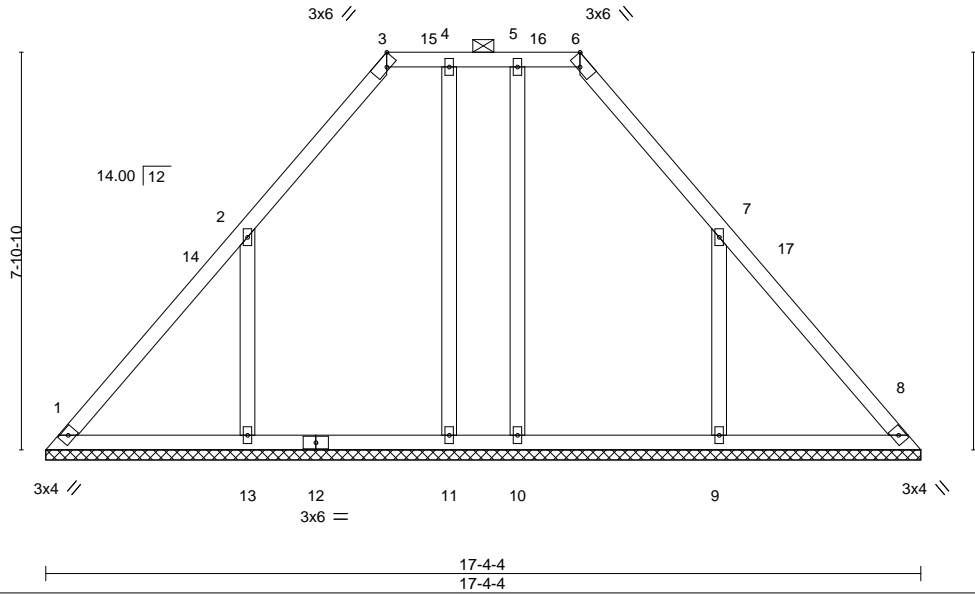

Plate Offsets (X,Y)--	[3:0-2-11,Edge], [6:0-2-11,Edge]				
<b>LOADING</b> (psf)	<b>SPACING-</b> 2-0-0	<b>CSI.</b>	<b>DEFL.</b> in (loc) l/defl L/d	<b>PLATES</b>	<b>GRIP</b>
TCLL 20.0	Plate Grip DOL 1.15	TC 0.34	Vert(LL) n/a - n/a 999	MT20	244/190
TCDL 10.0	Lumber DOL 1.15	BC 0.24	Vert(CT) n/a - n/a 999		
BCLL 0.0 *	Rep Stress Incr YES	WB 0.14	Horz(CT) 0.01 8 n/a n/a		
BCDL 10.0	Code IRC2015/TPI2014	Matrix-S		Weight: 95 lb	FT = 20%

<b>LUMBER-</b>	<b>BRACING-</b>
TOP CHORD 2x4 SP No.3	TOP CHORD Structural wood sheathing directly applied or 6-0-0 oc purlins, except 2-0-0 oc purlins (6-0-0 max.): 3-6.
BOT CHORD 2x4 SP No.3	BOT CHORD Rigid ceiling directly applied or 10-0-0 oc bracing.
OTHERS 2x4 SP No.3	

**REACTIONS.** All bearings 17-4-4.  
 (lb) - Max Horz 1=200(LC 8)  
 Max Uplift All uplift 100 lb or less at joint(s) 1, 8, 10, 11 except 9=272(LC 13), 13=273(LC 12)  
 Max Grav All reactions 250 lb or less at joint(s) 1, 8, 10, 11 except 9=471(LC 20), 13=473(LC 19)

**FORCES.** (lb) - Max. Comp./Max. Ten. - All forces 250 (lb) or less except when shown.  
 TOP CHORD 1-2=-269/148, 7-8=-267/134  
 WEBS 7-9=-364/310, 2-13=-364/312

- NOTES-**
- 1) Unbalanced roof live loads have been considered for this design.
  - 2) Wind: ASCE 7-10; Vult=130mph (3-second gust) Vasd=103mph; TCDL=6.0psf; BCDL=6.0psf; h=32ft; Cat. II; Exp B; Enclosed; MWFRS (envelope) gable end zone and C-C Exterior(2) 0-3-13 to 3-3-13, Interior(1) 3-3-13 to 6-9-2, Exterior(2) 6-9-2 to 9-9-2, Interior(1) 9-9-2 to 10-7-2, Exterior(2) 10-7-2 to 13-4-4, Interior(1) 13-4-4 to 17-0-7 zone; cantilever left and right exposed ; end vertical left and right exposed;C-C for members and forces & MWFRS for reactions shown; Lumber DOL=1.60 plate grip DOL=1.60
  - 3) Provide adequate drainage to prevent water ponding.
  - 4) All plates are 2x4 MT20 unless otherwise indicated.
  - 5) Gable requires continuous bottom chord bearing.
  - 6) This truss has been designed for a 10.0 psf bottom chord live load nonconcurrent with any other live loads.
  - 7) \* This truss has been designed for a live load of 20.0psf on the bottom chord in all areas where a rectangle 3-6-0 tall by 2-0-0 wide will fit between the bottom chord and any other members, with BCDL = 10.0psf.
  - 8) Provide mechanical connection (by others) of truss to bearing plate capable of withstanding 100 lb uplift at joint(s) 1, 8, 10, 11 except (jt=lb) 9=272, 13=273.
  - 9) Graphical purlin representation does not depict the size or the orientation of the purlin along the top and/or bottom chord.



February 15, 2021

<p><b>WARNING - Verify design parameters and READ NOTES ON THIS AND INCLUDED MITEK REFERENCE PAGE MII-7473 rev. 5/19/2020 BEFORE USE.</b>          Design valid for use only with MiTek® connectors. This design is based only upon parameters shown, and is for an individual building component, not a truss system. Before use, the building designer must verify the applicability of design parameters and properly incorporate this design into the overall building design. Bracing indicated is to prevent buckling of individual truss web and/or chord members only. Additional temporary and permanent bracing is always required for stability and to prevent collapse with possible personal injury and property damage. For general guidance regarding the fabrication, storage, delivery, erection and bracing of trusses and truss systems, see <b>ANSI/TPI1 Quality Criteria, DSB-89 and BCSI Building Component Safety Information</b> available from Truss Plate Institute, 2670 Crain Highway, Suite 203 Waldorf, MD 20601</p>	<p>ENGINEERING BY  <b>TRENCO</b>          A MiTek Affiliate</p> <p>818 Soundside Road          Edenton, NC 27932</p>
--	--

Job MASTER_RT130	Truss V11	Truss Type VALLEY	Qty 1	Ply 1	MCKEE; NELSON	144818046
---------------------	--------------	----------------------	----------	----------	---------------	-----------

Builders FirstSource (Apex, NC),

Apex, NC - 27523,

8.240 s Mar 9 2020 MiTek Industries, Inc. Mon Feb 15 14:20:27 2021 Page 1

ID:f0X\_NZYyOMto?npzE4iXPzyeg2c-AIQVcgK\_2uIYc7hqbVP82oritMoVWzgZSPk9XDzksto

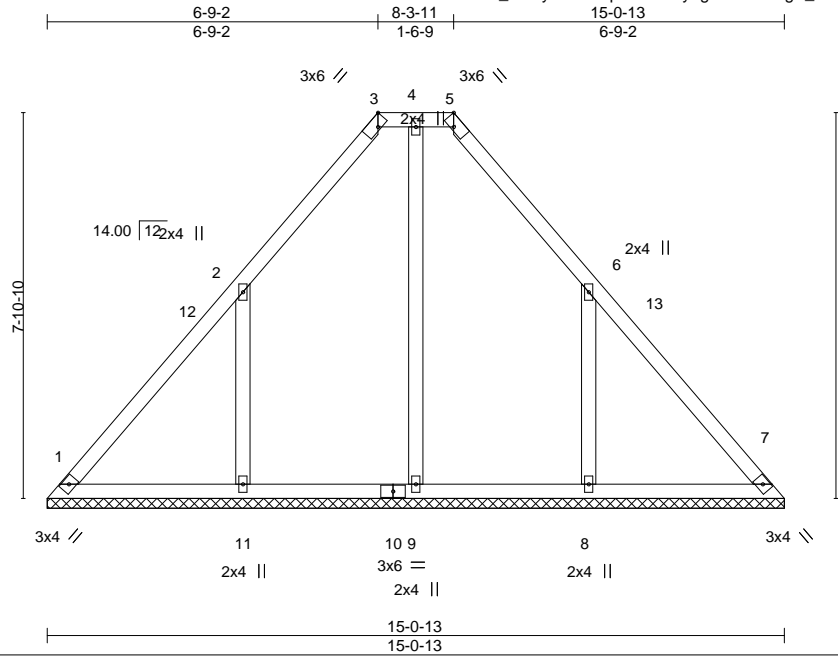

Scale = 1:47.1

Plate Offsets (X,Y)--	[3:0-2-11,Edge], [5:0-2-11,Edge]				
<b>LOADING</b> (psf)	<b>SPACING-</b> 2-0-0	<b>CSI.</b>	<b>DEFL.</b> in (loc) l/defl L/d	<b>PLATES</b>	<b>GRIP</b>
TCLL 20.0	Plate Grip DOL 1.15	TC 0.34	Vert(LL) n/a - n/a 999	MT20	244/190
TCDL 10.0	Lumber DOL 1.15	BC 0.24	Vert(CT) n/a - n/a 999		
BCLL 0.0 *	Rep Stress Incr YES	WB 0.14	Horz(CT) 0.00 7 n/a n/a		
BCDL 10.0	Code IRC2015/TPI2014	Matrix-S		Weight: 77 lb	FT = 20%

<b>LUMBER-</b>	<b>BRACING-</b>
TOP CHORD 2x4 SP No.3	TOP CHORD Structural wood sheathing directly applied or 6-0-0 oc purlins, except
BOT CHORD 2x4 SP No.3	2-0-0 oc purlins (6-0-0 max.): 3-5.
OTHERS 2x4 SP No.3	BOT CHORD Rigid ceiling directly applied or 10-0-0 oc bracing.

**REACTIONS.** All bearings 15-0-13.  
 (lb) - Max Horz 1=200(LC 8)  
 Max Uplift All uplift 100 lb or less at joint(s) 1, 7 except 8=282(LC 13), 11=282(LC 12)  
 Max Grav All reactions 250 lb or less at joint(s) 1, 7 except 9=307(LC 22), 8=454(LC 20), 11=454(LC 19)

**FORCES.** (lb) - Max. Comp./Max. Ten. - All forces 250 (lb) or less except when shown.  
 WEBS 6-8=-371/316, 2-11=-371/316

- NOTES-**
- Unbalanced roof live loads have been considered for this design.
  - Wind: ASCE 7-10; Vult=130mph (3-second gust) Vasd=103mph; TCDL=6.0psf; BCDL=6.0psf; h=32ft; Cat. II; Exp B; Enclosed; MWFRS (envelope) gable end zone and C-C Exterior(2) 0-3-13 to 3-3-13, Interior(1) 3-3-13 to 6-9-2, Exterior(2) 6-9-2 to 11-0-13, Interior(1) 11-0-13 to 14-9-0 zone; cantilever left and right exposed ; end vertical left and right exposed;C-C for members and forces & MWFRS for reactions shown; Lumber DOL=1.60 plate grip DOL=1.60
  - Provide adequate drainage to prevent water ponding.
  - Gable requires continuous bottom chord bearing.
  - This truss has been designed for a 10.0 psf bottom chord live load nonconcurrent with any other live loads.
  - \* This truss has been designed for a live load of 20.0psf on the bottom chord in all areas where a rectangle 3-6-0 tall by 2-0-0 wide will fit between the bottom chord and any other members, with BCDL = 10.0psf.
  - Provide mechanical connection (by others) of truss to bearing plate capable of withstanding 100 lb uplift at joint(s) 1, 7 except (jt=lb) 8=282, 11=282.
  - Graphical purlin representation does not depict the size or the orientation of the purlin along the top and/or bottom chord.



February 15, 2021

Job MASTER_RT130	Truss V12	Truss Type VALLEY	Qty 1	Ply 1	MCKEE; NELSON	144818047
---------------------	--------------	----------------------	----------	----------	---------------	-----------

Builders FirstSource (Apex, NC), Apex, NC - 27523,

8.240 s Mar 9 2020 MiTek Industries, Inc. Mon Feb 15 14:20:28 2021 Page 1  
ID:f0X\_NZYyOMto?npzE4iXPzyeg2c-eU\_tP0LcpBQPEHG09CwNb0Ntzm9JFQmih3Tj3fzkstn

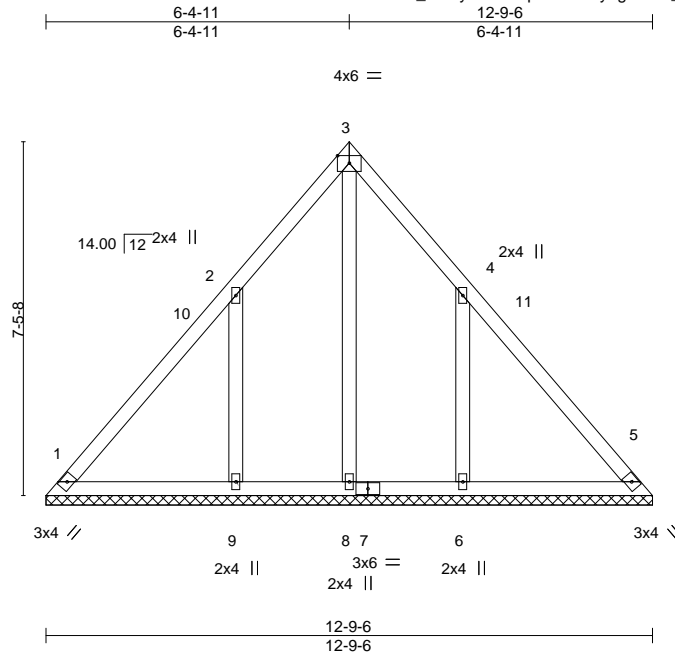

Scale = 1:48.6

Plate Offsets (X, Y)--		[3:Edge,0-1-14]								
<b>LOADING</b> (psf)	<b>SPACING-</b>	2-0-0	<b>CSI.</b>	<b>DEFL.</b>	in (loc)	l/defl	L/d	<b>PLATES</b>	<b>GRIP</b>	
TCLL 20.0	Plate Grip DOL	1.15	TC 0.34	Vert(LL)	n/a	-	n/a	999	MT20	244/190
TCDL 10.0	Lumber DOL	1.15	BC 0.18	Vert(CT)	n/a	-	n/a	999		
BCLL 0.0 *	Rep Stress Incr	YES	WB 0.15	Horz(CT)	0.00	5	n/a	n/a		
BCDL 10.0	Code IRC2015/TPI2014		Matrix-S						Weight: 69 lb	FT = 20%

**LUMBER-**  
TOP CHORD 2x4 SP No.3  
BOT CHORD 2x4 SP No.3  
OTHERS 2x4 SP No.3

**BRACING-**  
TOP CHORD Structural wood sheathing directly applied or 6-0-0 oc purlins.  
BOT CHORD Rigid ceiling directly applied or 10-0-0 oc bracing.

**REACTIONS.** All bearings 12-9-6.  
(lb) - Max Horz 1=187(LC 9)  
Max Uplift All uplift 100 lb or less at joint(s) 1 except 6=-267(LC 13), 9=-268(LC 12)  
Max Grav All reactions 250 lb or less at joint(s) 1, 5, 8 except 6=411(LC 20), 9=412(LC 19)

**FORCES.** (lb) - Max. Comp./Max. Ten. - All forces 250 (lb) or less except when shown.  
WEBS 4-6=-360/294, 2-9=-360/294

**NOTES-**

- 1) Unbalanced roof live loads have been considered for this design.
- 2) Wind: ASCE 7-10; Vult=130mph (3-second gust) Vasd=103mph; TCDL=6.0psf; BCDL=6.0psf; h=32ft; Cat. II; Exp B; Enclosed; MWFRS (envelope) gable end zone and C-C Exterior(2) 0-3-13 to 3-3-13, Interior(1) 3-3-13 to 6-4-11, Exterior(2) 6-4-11 to 9-4-11, Interior(1) 9-4-11 to 12-5-9 zone; cantilever left and right exposed ; end vertical left and right exposed;C-C for members and forces & MWFRS for reactions shown; Lumber DOL=1.60 plate grip DOL=1.60
- 3) Gable requires continuous bottom chord bearing.
- 4) This truss has been designed for a 10.0 psf bottom chord live load nonconcurrent with any other live loads.
- 5) \* This truss has been designed for a live load of 20.0psf on the bottom chord in all areas where a rectangle 3-6-0 tall by 2-0-0 wide will fit between the bottom chord and any other members, with BCDL = 10.0psf.
- 6) Provide mechanical connection (by others) of truss to bearing plate capable of withstanding 100 lb uplift at joint(s) 1 except (jt=lb) 6=267, 9=268.

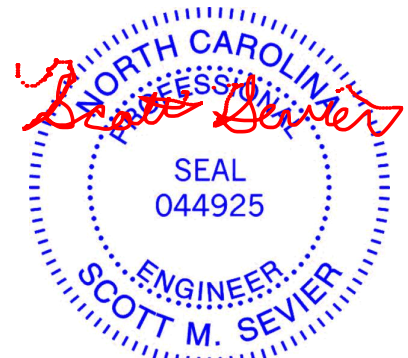

February 15, 2021

**WARNING - Verify design parameters and READ NOTES ON THIS AND INCLUDED MITEK REFERENCE PAGE MII-7473 rev. 5/19/2020 BEFORE USE.**

Design valid for use only with MiTek® connectors. This design is based only upon parameters shown, and is for an individual building component, not a truss system. Before use, the building designer must verify the applicability of design parameters and properly incorporate this design into the overall building design. Bracing indicated is to prevent buckling of individual truss web and/or chord members only. Additional temporary and permanent bracing is always required for stability and to prevent collapse with possible personal injury and property damage. For general guidance regarding the fabrication, storage, delivery, erection and bracing of trusses and truss systems, see

**Safety Information** available from Truss Plate Institute, 2670 Crain Highway, Suite 203 Waldorf, MD 20601  
**ANSI/TPI1 Quality Criteria, DSB-89 and BCSI Building Component**



818 Soundside Road  
Edenton, NC 27932



Job MASTER_RT130	Truss V13	Truss Type VALLEY	Qty 1	Ply 1	MCKEE; NELSON	144818048
---------------------	--------------	----------------------	----------	----------	---------------	-----------

Builders FirstSource (Apex, NC),

Apex, NC - 27523,

8.240 s Mar 9 2020 MiTek Industries, Inc. Mon Feb 15 14:20:30 2021 Page 1  
ID:f0X\_NZYyOMto?npzE4iXPzyeg2c-bt6eqiNtLpg7TaQPdgyrgRTCLaq5jLc?8Nyp8Yzkstl

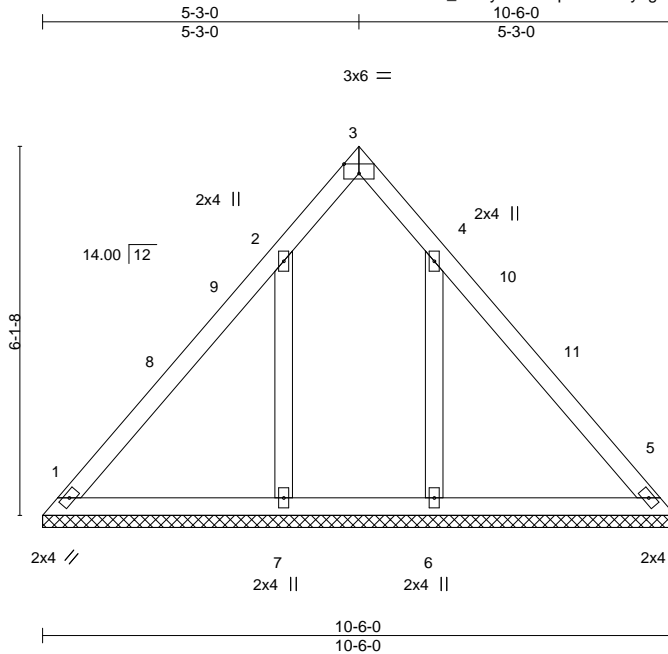

Scale = 1:38.2

Plate Offsets (X, Y)--		[3:Edge, 0-1-14]								
<b>LOADING</b> (psf)	<b>SPACING-</b>	2-0-0	<b>CSI.</b>	<b>DEFL.</b>	in (loc)	l/defl	L/d	<b>PLATES</b>	<b>GRIP</b>	
TCLL 20.0	Plate Grip DOL	1.15	TC 0.39	Vert(LL)	n/a	-	n/a	999	MT20	244/190
TCDL 10.0	Lumber DOL	1.15	BC 0.18	Vert(CT)	n/a	-	n/a	999		
BCLL 0.0 *	Rep Stress Incr	YES	WB 0.12	Horz(CT)	0.00	5	n/a	n/a		
BCDL 10.0	Code	IRC2015/TPI2014	Matrix-S						Weight: 51 lb	FT = 20%

**LUMBER-**  
 TOP CHORD 2x4 SP No.3  
 BOT CHORD 2x4 SP No.3  
 OTHERS 2x4 SP No.3

**BRACING-**  
 TOP CHORD Structural wood sheathing directly applied or 6-0-0 oc purlins.  
 BOT CHORD Rigid ceiling directly applied or 6-0-0 oc bracing.

**REACTIONS.** All bearings 10-6-0.  
 (lb) - Max Horz 1=-151(LC 8)  
 Max Uplift All uplift 100 lb or less at joint(s) except 6=-247(LC 13), 7=-250(LC 12)  
 Max Grav All reactions 250 lb or less at joint(s) 1, 5 except 6=399(LC 20), 7=403(LC 19)

**FORCES.** (lb) - Max. Comp./Max. Ten. - All forces 250 (lb) or less except when shown.  
 TOP CHORD 1-2=-278/259, 4-5=-278/259  
 WEBS 4-6=-350/291, 2-7=-350/291

- NOTES-**
- Unbalanced roof live loads have been considered for this design.
  - Wind: ASCE 7-10; Vult=130mph (3-second gust) Vasd=103mph; TC DL=6.0psf; BCDL=6.0psf; h=32ft; Cat. II; Exp B; Enclosed; MWFRS (envelope) gable end zone and C-C Exterior(2) 0-3-13 to 3-3-13, Interior(1) 3-3-13 to 5-3-0, Exterior(2) 5-3-0 to 8-3-0, Interior(1) 8-3-0 to 10-2-3 zone; cantilever left and right exposed; end vertical left and right exposed; C-C for members and forces & MWFRS for reactions shown; Lumber DOL=1.60 plate grip DOL=1.60
  - Gable requires continuous bottom chord bearing.
  - This truss has been designed for a 10.0 psf bottom chord live load nonconcurrent with any other live loads.
  - \* This truss has been designed for a live load of 20.0psf on the bottom chord in all areas where a rectangle 3-6-0 tall by 2-0-0 wide will fit between the bottom chord and any other members, with BCDL = 10.0psf.
  - Provide mechanical connection (by others) of truss to bearing plate capable of withstanding 247 lb uplift at joint 6 and 250 lb uplift at joint 7.

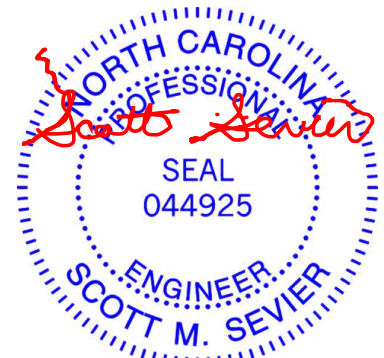

February 15, 2021

**WARNING - Verify design parameters and READ NOTES ON THIS AND INCLUDED MITEK REFERENCE PAGE MII-7473 rev. 5/19/2020 BEFORE USE.**

Design valid for use only with MiTek® connectors. This design is based only upon parameters shown, and is for an individual building component, not a truss system. Before use, the building designer must verify the applicability of design parameters and properly incorporate this design into the overall building design. Bracing indicated is to prevent buckling of individual truss web and/or chord members only. Additional temporary and permanent bracing is always required for stability and to prevent collapse with possible personal injury and property damage. For general guidance regarding the fabrication, storage, delivery, erection and bracing of trusses and truss systems, see

**ANSI/TPI1 Quality Criteria, DSB-89 and BCSI Building Component**

**Safety Information** available from Truss Plate Institute, 2670 Crain Highway, Suite 203 Waldorf, MD 20601



818 Soundside Road  
 Edenton, NC 27932

Job MASTER_RT130	Truss V14	Truss Type VALLEY	Qty 1	Ply 1	MCKEE; NELSON	144818049
---------------------	--------------	----------------------	----------	----------	---------------	-----------

Builders FirstSource (Apex, NC),

Apex, NC - 27523,

8.240 s Mar 9 2020 MiTek Industries, Inc. Mon Feb 15 14:20:31 2021 Page 1

ID:f0X\_NZYyOMto?npzE4iXPzyeg2c-33g012NV66o\_5k?bqKU4De?OH\_9JSpw9N1iNg\_zkstk

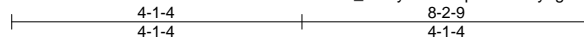

4x6 =

Scale = 1:32.6

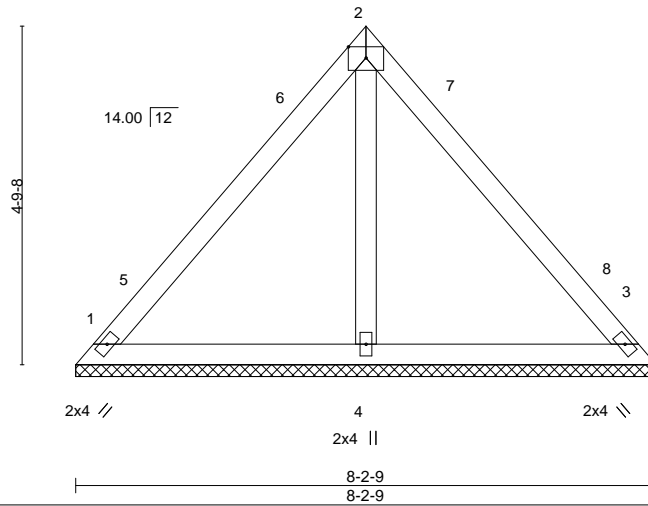

Plate Offsets (X,Y)--		[2:Edge,0-1-14]								
<b>LOADING</b> (psf)	<b>SPACING-</b>	2-0-0	<b>CSI.</b>	<b>DEFL.</b>	in (loc)	l/defl	L/d	<b>PLATES</b>	<b>GRIP</b>	
TCLL 20.0	Plate Grip DOL	1.15	TC 0.38	Vert(LL)	n/a	-	n/a	999	MT20	244/190
TCDL 10.0	Lumber DOL	1.15	BC 0.25	Vert(CT)	n/a	-	n/a	999		
BCLL 0.0 *	Rep Stress Incr	YES	WB 0.06	Horz(CT)	0.00	3	n/a	n/a		
BCDL 10.0	Code	IRC2015/TPI2014	Matrix-S						Weight: 36 lb	FT = 20%

**LUMBER-**  
 TOP CHORD 2x4 SP No.3  
 BOT CHORD 2x4 SP No.3  
 OTHERS 2x4 SP No.3

**BRACING-**  
 TOP CHORD Structural wood sheathing directly applied or 6-0-0 oc purlins.  
 BOT CHORD Rigid ceiling directly applied or 10-0-0 oc bracing.

**REACTIONS.** (size) 1=8-2-9, 3=8-2-9, 4=8-2-9  
 Max Horz 1=116(LC 11)  
 Max Uplift 1=-40(LC 13), 3=-29(LC 12), 4=-6(LC 12)  
 Max Grav 1=176(LC 1), 3=176(LC 1), 4=255(LC 1)

**FORCES.** (lb) - Max. Comp./Max. Ten. - All forces 250 (lb) or less except when shown.

**NOTES-**

- Unbalanced roof live loads have been considered for this design.
- Wind: ASCE 7-10; Vult=130mph (3-second gust) Vasd=103mph; TC DL=6.0psf; BCDL=6.0psf; h=32ft; Cat. II; Exp B; Enclosed; MWFRS (envelope) gable end zone and C-C Exterior(2) 0-3-13 to 3-3-13, Interior(1) 3-3-13 to 4-1-4, Exterior(2) 4-1-4 to 7-1-4, Interior(1) 7-1-4 to 7-10-12 zone; cantilever left and right exposed; end vertical left and right exposed; C-C for members and forces & MWFRS for reactions shown; Lumber DOL=1.60 plate grip DOL=1.60
- Gable requires continuous bottom chord bearing.
- This truss has been designed for a 10.0 psf bottom chord live load nonconcurrent with any other live loads.
- \* This truss has been designed for a live load of 20.0psf on the bottom chord in all areas where a rectangle 3-6-0 tall by 2-0-0 wide will fit between the bottom chord and any other members.
- Provide mechanical connection (by others) of truss to bearing plate capable of withstanding 40 lb uplift at joint 1, 29 lb uplift at joint 3 and 6 lb uplift at joint 4.



February 15, 2021

**WARNING - Verify design parameters and READ NOTES ON THIS AND INCLUDED MITEK REFERENCE PAGE MII-7473 rev. 5/19/2020 BEFORE USE.**

Design valid for use only with MiTek® connectors. This design is based only upon parameters shown, and is for an individual building component, not a truss system. Before use, the building designer must verify the applicability of design parameters and properly incorporate this design into the overall building design. Bracing indicated is to prevent buckling of individual truss web and/or chord members only. Additional temporary and permanent bracing is always required for stability and to prevent collapse with possible personal injury and property damage. For general guidance regarding the fabrication, storage, delivery, erection and bracing of trusses and truss systems, see

**ANSI/TPI1 Quality Criteria, DSB-89 and BCSI Building Component**

**Safety Information** available from Truss Plate Institute, 2670 Crain Highway, Suite 203 Waldorf, MD 20601



818 Soundside Road  
 Edenton, NC 27932

Job MASTER_RT130	Truss V15	Truss Type VALLEY	Qty 1	Ply 1	MCKEE; NELSON Job Reference (optional)	144818050
---------------------	--------------	----------------------	----------	----------	---	-----------

Builders FirstSource (Apex, NC),

Apex, NC - 27523,

8.240 s Mar 9 2020 MiTek Industries, Inc. Mon Feb 15 14:20:33 2021 Page 1  
ID:f0X\_NZYyOMto?npzE4iXPzyeg2c-?SomSkPldk2iK28\_ylWYI35IBntnwjvSqLBUktzksti

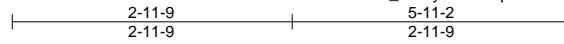

4x6 =

Scale = 1:24.4

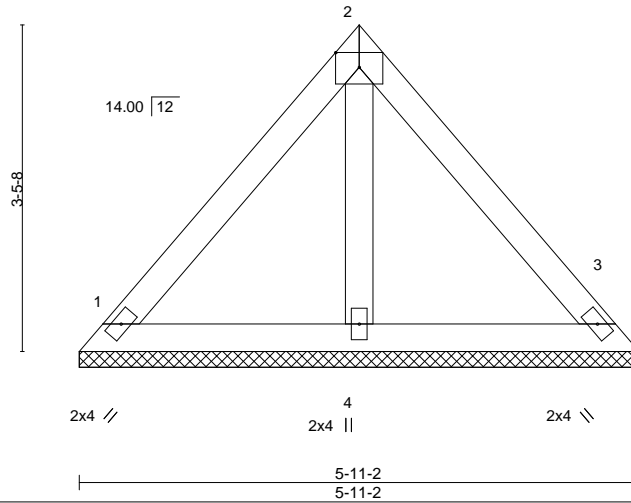

Plate Offsets (X,Y)--		[2:Edge,0-1-14]								
<b>LOADING</b> (psf)	<b>SPACING-</b>	2-0-0	<b>CSI.</b>	<b>DEFL.</b>	in (loc)	l/defl	L/d	<b>PLATES</b>	<b>GRIP</b>	
TCLL 20.0	Plate Grip DOL	1.15	TC 0.29	Vert(LL)	n/a	-	n/a	999	MT20	244/190
TCDL 10.0	Lumber DOL	1.15	BC 0.12	Vert(CT)	n/a	-	n/a	999		
BCLL 0.0 *	Rep Stress Incr	YES	WB 0.02	Horz(CT)	0.00	3	n/a	n/a		
BCDL 10.0	Code	IRC2015/TPI2014	Matrix-P						Weight: 25 lb	FT = 20%

**LUMBER-**  
TOP CHORD 2x4 SP No.3  
BOT CHORD 2x4 SP No.3  
OTHERS 2x4 SP No.3

**BRACING-**  
TOP CHORD Structural wood sheathing directly applied or 5-11-2 oc purlins.  
BOT CHORD Rigid ceiling directly applied or 10-0-0 oc bracing.

**REACTIONS.** (size) 1=5-11-2, 3=5-11-2, 4=5-11-2  
Max Horz 1=-81(LC 8)  
Max Uplift 1=-38(LC 13), 3=-30(LC 12)  
Max Grav 1=132(LC 1), 3=132(LC 1), 4=164(LC 3)

**FORCES.** (lb) - Max. Comp./Max. Ten. - All forces 250 (lb) or less except when shown.

**NOTES-**

- 1) Unbalanced roof live loads have been considered for this design.
- 2) Wind: ASCE 7-10; Vult=130mph (3-second gust) Vasd=103mph; TC DL=6.0psf; BCDL=6.0psf; h=32ft; Cat. II; Exp B; Enclosed; MWFRS (envelope) gable end zone and C-C Exterior(2) zone; cantilever left and right exposed; end vertical left and right exposed; C-C for members and forces & MWFRS for reactions shown; Lumber DOL=1.60 plate grip DOL=1.60
- 3) Gable requires continuous bottom chord bearing.
- 4) This truss has been designed for a 10.0 psf bottom chord live load nonconcurrent with any other live loads.
- 5) \* This truss has been designed for a live load of 20.0psf on the bottom chord in all areas where a rectangle 3-6-0 tall by 2-0-0 wide will fit between the bottom chord and any other members.
- 6) Provide mechanical connection (by others) of truss to bearing plate capable of withstanding 38 lb uplift at joint 1 and 30 lb uplift at joint 3.



February 15, 2021

**WARNING - Verify design parameters and READ NOTES ON THIS AND INCLUDED MITEK REFERENCE PAGE MII-7473 rev. 5/19/2020 BEFORE USE.**

Design valid for use only with MiTek® connectors. This design is based only upon parameters shown, and is for an individual building component, not a truss system. Before use, the building designer must verify the applicability of design parameters and properly incorporate this design into the overall building design. Bracing indicated is to prevent buckling of individual truss web and/or chord members only. Additional temporary and permanent bracing is always required for stability and to prevent collapse with possible personal injury and property damage. For general guidance regarding the fabrication, storage, delivery, erection and bracing of trusses and truss systems, see

**ANSI/TPI1 Quality Criteria, DSB-89 and BCSI Building Component**

**Safety Information** available from Truss Plate Institute, 2670 Crain Highway, Suite 203 Waldorf, MD 20601



818 Soundside Road  
Edenton, NC 27932

Job MASTER_RT130	Truss V16	Truss Type VALLEY	Qty 1	Ply 1	MCKEE; NELSON	144818051
---------------------	--------------	----------------------	----------	----------	---------------	-----------

Builders FirstSource (Apex, NC), Apex, NC - 27523,

8.240 s Mar 9 2020 MiTek Industries, Inc. Mon Feb 15 14:20:34 2021 Page 1

ID:f0X\_NZYyOMto?npzE4iXPzyeg2c-TeL9g3QNO1AZyCjAVT1nrHdzzBC6fAWb3?w1HJzksth

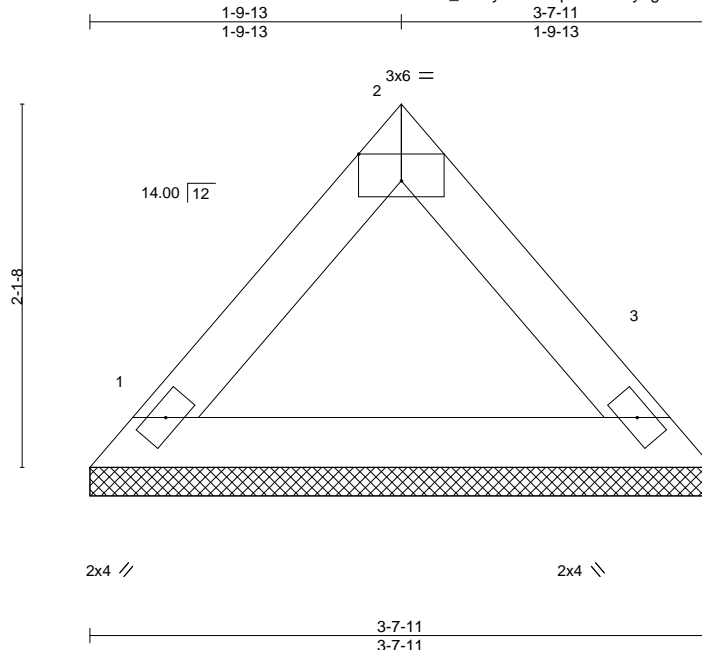

Scale = 1:13.5

Plate Offsets (X,Y)--	[2:Edge,0-1-14]					PLATES	GRIP			
LOADING (psf)	SPACING-	2-0-0	CSI.	DEFL.	in (loc)	l/defl	L/d	PLATES	GRIP	
TCLL 20.0	Plate Grip DOL	1.15	TC 0.09	Vert(LL)	n/a	-	n/a	999	MT20	244/190
TCDL 10.0	Lumber DOL	1.15	BC 0.18	Vert(CT)	n/a	-	n/a	999		
BCLL 0.0 *	Rep Stress Incr	YES	WB 0.00	Horz(CT)	0.00	3	n/a	n/a		
BCDL 10.0	Code	IRC2015/TPI2014	Matrix-P						Weight: 13 lb	FT = 20%

LUMBER-	BRACING-
TOP CHORD 2x4 SP No.3	TOP CHORD Structural wood sheathing directly applied or 3-7-11 oc purlins.
BOT CHORD 2x4 SP No.3	BOT CHORD Rigid ceiling directly applied or 10-0-0 oc bracing.

**REACTIONS.** (size) 1=3-7-11, 3=3-7-11  
 Max Horz 1=-46(LC 8)  
 Max Uplift 1=-13(LC 13), 3=-13(LC 12)  
 Max Grav 1=120(LC 1), 3=120(LC 1)

**FORCES.** (lb) - Max. Comp./Max. Ten. - All forces 250 (lb) or less except when shown.

- NOTES-**
- 1) Unbalanced roof live loads have been considered for this design.
  - 2) Wind: ASCE 7-10; Vult=130mph (3-second gust) Vasd=103mph; TC DL=6.0psf; BCDL=6.0psf; h=32ft; Cat. II; Exp B; Enclosed; MWFRS (envelope) gable end zone and C-C Exterior(2) zone; cantilever left and right exposed ; end vertical left and right exposed;C-C for members and forces & MWFRS for reactions shown; Lumber DOL=1.60 plate grip DOL=1.60
  - 3) Gable requires continuous bottom chord bearing.
  - 4) This truss has been designed for a 10.0 psf bottom chord live load nonconcurrent with any other live loads.
  - 5) \* This truss has been designed for a live load of 20.0psf on the bottom chord in all areas where a rectangle 3-6-0 tall by 2-0-0 wide will fit between the bottom chord and any other members.
  - 6) Provide mechanical connection (by others) of truss to bearing plate capable of withstanding 13 lb uplift at joint 1 and 13 lb uplift at joint 3.



February 15, 2021

Job MASTER_RT130	Truss V17	Truss Type VALLEY	Qty 1	Ply 1	MCKEE; NELSON Job Reference (optional)	144818052
---------------------	--------------	----------------------	----------	----------	---	-----------

Builders FirstSource (Apex, NC), Apex, NC - 27523, 8.240 s Mar 9 2020 MiTek Industries, Inc. Mon Feb 15 14:20:35 2021 Page 1  
 ID:f0X\_NZYyOMto?npzE4iXPzyeg2c-xrvXtPQ?9LIQaMIM3AY0NUA86bX7Ocmkfgapzkstg

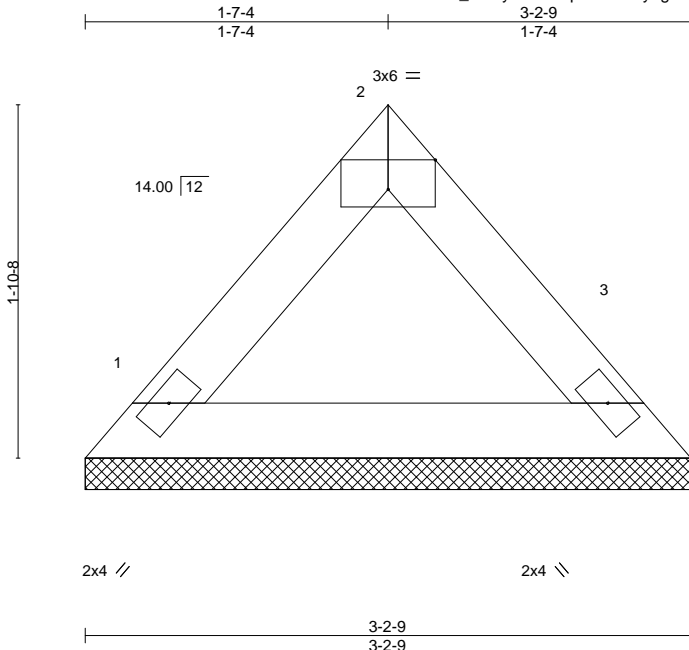

Scale = 1:12.2

Plate Offsets (X,Y)--	[2:Edge,0-1-14]								
<b>LOADING</b> (psf)	<b>SPACING-</b>	2-0-0	<b>CSI.</b>	<b>DEFL.</b>	in (loc)	l/defl	L/d	<b>PLATES</b>	<b>GRIP</b>
TCLL 20.0	Plate Grip DOL	1.15	TC 0.07	Vert(LL)	n/a	-	n/a	MT20	244/190
TCDL 10.0	Lumber DOL	1.15	BC 0.13	Vert(CT)	n/a	-	n/a		
BCLL 0.0 *	Rep Stress Incr	YES	WB 0.00	Horz(CT)	0.00	3	n/a		
BCDL 10.0	Code IRC2015/TPI2014		Matrix-P					Weight: 11 lb	FT = 20%

**LUMBER-**  
 TOP CHORD 2x4 SP No.3  
 BOT CHORD 2x4 SP No.3

**BRACING-**  
 TOP CHORD Structural wood sheathing directly applied or 3-2-9 oc purlins.  
 BOT CHORD Rigid ceiling directly applied or 10-0-0 oc bracing.

**REACTIONS.** (size) 1=3-2-9, 3=3-2-9  
 Max Horz 1=40(LC 8)  
 Max Uplift 1=-11(LC 13), 3=-11(LC 12)  
 Max Grav 1=103(LC 1), 3=103(LC 1)

**FORCES.** (lb) - Max. Comp./Max. Ten. - All forces 250 (lb) or less except when shown.

**NOTES-**

- 1) Unbalanced roof live loads have been considered for this design.
- 2) Wind: ASCE 7-10; Vult=130mph (3-second gust) Vasd=103mph; TC DL=6.0psf; BCDL=6.0psf; h=32ft; Cat. II; Exp B; Enclosed; MWFRS (envelope) gable end zone and C-C Exterior(2) zone; cantilever left and right exposed ; end vertical left and right exposed;C-C for members and forces & MWFRS for reactions shown; Lumber DOL=1.60 plate grip DOL=1.60
- 3) Gable requires continuous bottom chord bearing.
- 4) This truss has been designed for a 10.0 psf bottom chord live load nonconcurrent with any other live loads.
- 5) \* This truss has been designed for a live load of 20.0psf on the bottom chord in all areas where a rectangle 3-6-0 tall by 2-0-0 wide will fit between the bottom chord and any other members.
- 6) Provide mechanical connection (by others) of truss to bearing plate capable of withstanding 11 lb uplift at joint 1 and 11 lb uplift at joint 3.



February 15, 2021

**WARNING - Verify design parameters and READ NOTES ON THIS AND INCLUDED MITEK REFERENCE PAGE MII-7473 rev. 5/19/2020 BEFORE USE.**  
 Design valid for use only with MiTek® connectors. This design is based only upon parameters shown, and is for an individual building component, not a truss system. Before use, the building designer must verify the applicability of design parameters and properly incorporate this design into the overall building design. Bracing indicated is to prevent buckling of individual truss web and/or chord members only. Additional temporary and permanent bracing is always required for stability and to prevent collapse with possible personal injury and property damage. For general guidance regarding the fabrication, storage, delivery, erection and bracing of trusses and truss systems, see **ANSI/TPI1 Quality Criteria, DSB-89 and BCSI Building Component Safety Information** available from Truss Plate Institute, 2670 Crain Highway, Suite 203 Waldorf, MD 20601



818 Soundside Road  
 Edenton, NC 27932

# Symbols

## PLATE LOCATION AND ORIENTATION



Center plate on joint unless x, y offsets are indicated. Dimensions are in ft-in-sixteenths. Apply plates to both sides of truss and fully embed teeth.



For 4 x 2 orientation, locate plates 0- 1/16" from outside edge of truss.



This symbol indicates the required direction of slots in connector plates.

\* Plate location details available in **MITek 20/20 software** or upon request.

## PLATE SIZE

**4 X 4**

The first dimension is the plate width measured perpendicular to slots. Second dimension is the length parallel to slots.

## LATERAL BRACING LOCATION



Indicated by symbol shown and/or by text in the bracing section of the output. Use T or I bracing if indicated.

## BEARING



Indicates location where bearings (supports) occur. Icons vary but reaction section indicates joint number where bearings occur. Min size shown is for crushing only.

### Industry Standards:

ANSI/TFP 1: National Design Specification for Metal Plate Connected Wood Truss Construction.  
DSB-89: Design Standard for Bracing.  
BCSI: Building Component Safety Information, Guide to Good Practice for Handling, Installing & Bracing of Metal Plate Connected Wood Trusses.

# Numbering System

6-4-8  
dimensions shown in ft-in-sixteenths  
(Drawings not to scale)



**JOINTS ARE GENERALLY NUMBERED/LETTERED CLOCKWISE AROUND THE TRUSS STARTING AT THE JOINT FARTHEST TO THE LEFT.**

**CHORDS AND WEBS ARE IDENTIFIED BY END JOINT NUMBERS/LETTERS.**

## PRODUCT CODE APPROVALS

ICC-ES Reports:

ESR-1311, ESR-1352, ESR1988  
ER-3907, ESR-2362, ESR-1397, ESR-3282

Trusses are designed for wind loads in the plane of the truss unless otherwise shown.

Lumber design values are in accordance with ANSI/TFP 1 section 6.3 These truss designs rely on lumber values established by others.

© 2012 MITteK® All Rights Reserved



MITek Engineering Reference Sheet: MII-7473 rev. 5/19/2020



# General Safety Notes

## Failure to Follow Could Cause Property Damage or Personal Injury

1. Additional stability bracing for truss system, e.g. diagonal or X-bracing, is always required. See BCSI.
2. Truss bracing must be designed by an engineer. For wide truss spacing, individual lateral braces themselves may require bracing, or alternative Tor I bracing should be considered.
3. Never exceed the design loading shown and never stack materials on inadequately braced trusses.
4. Provide copies of this truss design to the building designer, erection supervisor, property owner and all other interested parties.
5. Cut members to bear tightly against each other.
6. Place plates on each face of truss at each joint and embed fully. Knots and wane at joint locations are regulated by ANSI/TFP 1.
7. Design assumes trusses will be suitably protected from the environment in accord with ANSI/TFP 1.
8. Unless otherwise noted, moisture content of lumber shall not exceed 19% at time of fabrication.
9. Unless expressly noted, this design is not applicable for use with fire retardant, preservative treated, or green lumber.
10. Camber is a non-structural consideration and is the responsibility of truss fabricator. General practice is to camber for dead load deflection.
11. Plate type, size, orientation and location dimensions indicated are minimum plating requirements.
12. Lumber used shall be of the species and size, and in all respects, equal to or better than that specified.
13. Top chords must be sheathed or purlins provided at spacing indicated on design.
14. Bottom chords require lateral bracing at 10 ft. spacing, or less, if no ceiling is installed, unless otherwise noted.
15. Connections not shown are the responsibility of others.
16. Do not cut or alter truss member or plate without prior approval of an engineer.
17. Install and load vertically unless indicated otherwise.
18. Use of green or treated lumber may pose unacceptable environmental, health or performance risks. Consult with project engineer before use.
19. Review all portions of this design (front, back, words and pictures) before use. Rewriting pictures alone is not sufficient.
20. Design assumes manufacture in accordance with ANSI/TFP 1 Quality Criteria.
21. The design does not take into account any dynamic or other loads other than those expressly stated.