

Mark Morris, P.E.

#126, 1317-M, Summerville, SC 29483

843 209-5784, Fax (866)-213-4614

The truss drawing(s) listed below have been prepared by **Atlantic Building Components** under my direct supervision based on the parameters provided by the truss designers.

AST #: 24695

JOB: 20-5717-F02

JOB NAME: LOT 1161 CARRIAGE CIRCLE

Wind Code: N/A

Wind Speed: Vult= N/A

Exposure Category: N/A

Mean Roof Height (feet): N/A

8 Truss Design(s)

Trusses:

F01, F02, F03, F04, F06, F07, F08, F09



12/9/2020

Mark Morris

Warning !—Verify design parameters and read notes before use.

This design is based only upon parameters shown, and is for an individual building component to be installed and loaded vertically. Applicability of design parameters and proper incorporation of component is responsibility of building designer – not truss designer or truss engineer. Bracing shown is for lateral support of individual web members only. Additional temporary bracing to ensure stability during construction is the responsibility of the erector. Additional permanent bracing of the overall structure is the responsibility of the building designer. For general guidance regarding fabrication, quality control, storage, delivery, erection and bracing, consult ANSI/TPI 1 *National Design Standard for Metal Plate Connected Wood Truss Construction* and BCSI 1-03 Guide to

Job 20-5717-F02	Truss F01	Truss Type Floor	Qty 15	Ply 1	LOT 1161 CARRIAGE CIRCLE 116 SPRUCE HOLLOW CIRCLE SPRING LAKE, N	# 24695
--------------------	--------------	---------------------	-----------	----------	--------------------------------------------------------------------	---------

8.330 s Mar 10 2020 MiTek Industries, Inc. Thu Dec 10 21:06:53 2020 Page 1
 ID:VaeaK7vWB81xgotwPmaLleyLxWJ-lq8PBuv3ubcxTz6l9vTQeEqDcde9mQnvHWhjXXyAGD0

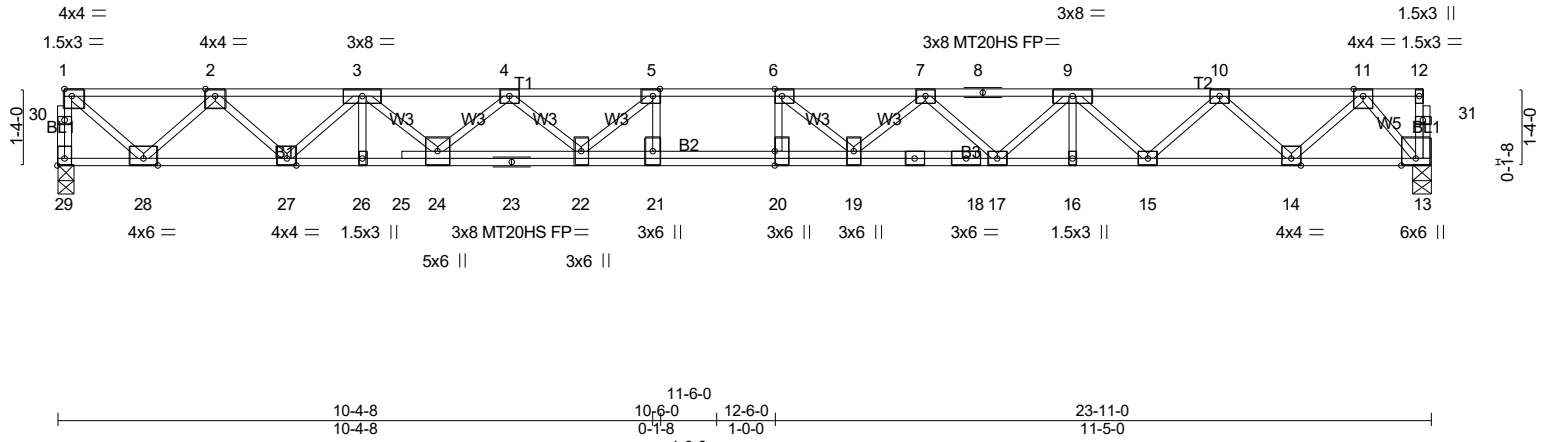

Plate Offsets (X,Y)-- [1:Edge,0-1-8], [5:0-1-8,Edge], [6:0-1-8,Edge], [20:0-3-0,0-0-0], [29:Edge,0-1-8]

LOADING (psf)	SPACING-	1-7-3	CSI.	DEFL. in (loc)	l/defl	L/d	PLATES	GRIP
TCLL 40.0	Plate Grip DOL	1.00	TC 0.68	Vert(LL) -0.47	20	>601	MT20	244/190
TCDL 10.0	Lumber DOL	1.00	BC 0.92	Vert(CT) -0.65	20	>437	MT20HS	187/143
BCLL 0.0	Rep Stress Incr	YES	WB 0.67	Horz(CT) 0.09	13	n/a		
BCDL 5.0	Code IRC2018/TPI2014		Matrix-SH					Weight: 138 lb FT = 0%F, 0%E

LUMBER-	BRACING-
TOP CHORD 2x4 SP No.1(flat)	TOP CHORD Structural wood sheathing directly applied or 4-11-11 oc purlins, except end verticals.
BOT CHORD 2x4 SP No.1(flat)	BOT CHORD Rigid ceiling directly applied or 10-0-0 oc bracing, Except: 2-2-0 oc bracing: 17-19.
WEBS 2x4 SP No.3(flat)	

REACTIONS. (lb/size) 29=1036/0-3-8 (min. 0-1-8), 13=1036/0-3-8 (min. 0-1-8)

FORCES. (lb) - Max. Comp./Max. Ten. - All forces 250 (lb) or less except when shown.
 TOP CHORD 29-30=-1031/0, 1-30=-1029/0, 1-2=-1081/0, 2-3=-2772/0, 3-4=-4179/0, 4-5=-5007/0, 5-6=-5313/0, 6-7=-5141/0, 7-8=-4344/0, 8-9=-4344/0, 9-10=-3263/0, 10-11=-1760/0
 BOT CHORD 27-28=0/2046, 26-27=0/3492, 25-26=0/3492, 24-25=0/3487, 23-24=0/4707, 22-23=0/4707, 21-22=0/5313, 20-21=0/5313, 19-20=0/5313, 18-19=0/4847, 17-18=0/4846, 16-17=0/3924, 15-16=0/3924, 14-15=0/2620, 13-14=0/877
 WEBS 5-21=-228/336, 6-20=-288/264, 5-22=-720/90, 4-22=0/492, 4-24=-715/0, 3-24=0/913, 3-27=-979/0, 2-27=0/1009, 2-28=-1342/0, 1-28=0/1397, 6-19=-592/200, 7-19=0/483, 7-17=-699/0, 9-17=0/571, 9-15=-898/0, 10-15=0/895, 10-14=-1196/0, 11-14=0/1227, 11-13=-1343/0

- NOTES-** (6-7)
- 1) Unbalanced floor live loads have been considered for this design.
 - 2) All plates are MT20 plates unless otherwise indicated.
 - 3) All plates are 3x4 MT20 unless otherwise indicated.
 - 4) This truss is designed in accordance with the 2018 International Residential Code sections R502.11.1 and R802.10.2 and referenced standard ANSI/TPI 1.
 - 5) Recommend 2x6 strongbacks, on edge, spaced at 10-0-0 oc and fastened to each truss with 3-10d (0.131" X 3") nails. Strongbacks to be attached to walls at their outer ends or restrained by other means.
 - 6) Graphical web bracing representation does not depict the size, type or the orientation of the brace on the web. Symbol only indicates that the member must be braced.
 - 7) Bearing symbols are only graphical representations of a possible bearing condition. Bearing symbols are not considered in the structural design of the truss to support the loads indicated.

LOAD CASE(S) Standard



12/9/2020

Warning !—Verify design parameters and read notes before use. This design is based only upon parameters shown, and is for an individual building component to be installed and loaded vertically. Applicability of design parameters and proper incorporation of component is responsibility of building designer – not truss designer or truss engineer. Bracing shown is for lateral support of individual web members only. Additional temporary bracing to ensure stability during construction is the responsibility of the erector. Additional permanent bracing of the overall structure is the responsibility of the building designer. For general guidance regarding fabrication, quality control, storage, delivery, erection and bracing, consult ANSI/TPI 1 *National Design Standard for Metal Plate Connected Wood Truss Construction* and BCSI 1-03 *Guide to Good Practice for Handling, Installing & Bracing of Metal Plate Connected Wood Trusses* from Truss Plate Institute, 583 D'Onofrio Drive, Madison, WI 53719.

Job 20-5717-F02	Truss F02	Truss Type Floor Supported Gable	Qty 2	Ply 1	LOT 1161 CARRIAGE CIRCLE 116 SPRUCE HOLLOW CIRCLE SPRING LAKE, N.C. Job Reference (optional) # 24695
--------------------	--------------	-------------------------------------	----------	----------	-----------------------------------------------------------------------------------------------------------

8.330 s Mar 10 2020 MiTek Industries, Inc. Thu Dec 10 21:06:54 2020 Page 1
ID:VaeaK7vWB81xgotwpMaLleyLxWJ-D0inOEwhevko56hUjc_fARMXq1CFV1t3V9QG4zyAGD?

0₁-8

0₁-8

Scale: 1/2"=1'

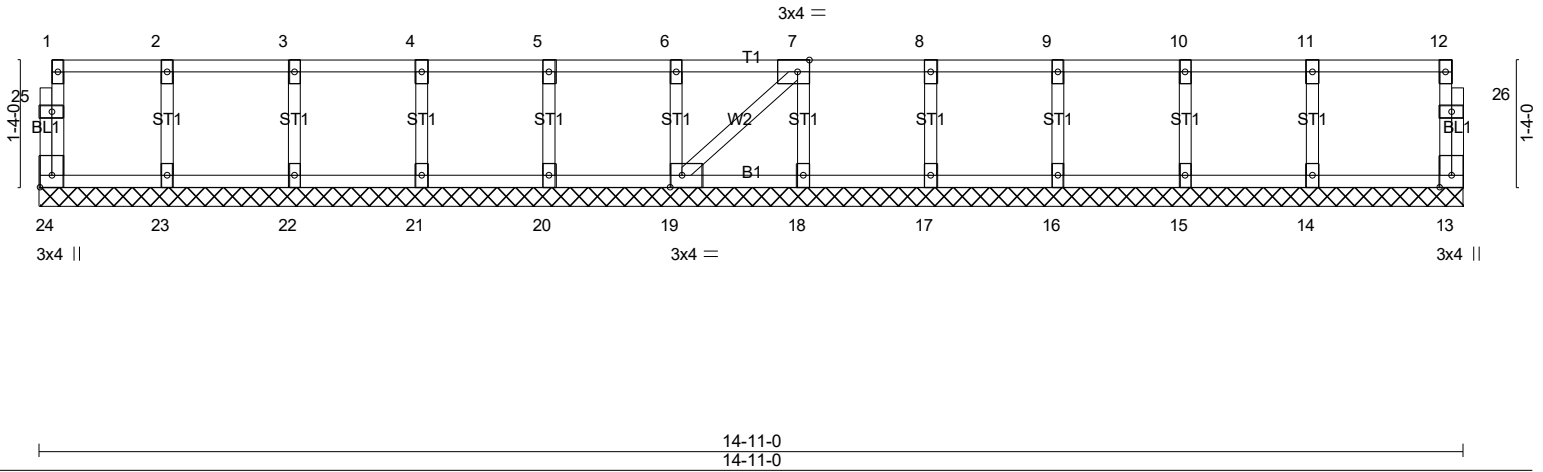

Plate Offsets (X,Y)-- [7:0-1-8,Edge], [19:0-1-8,Edge], [24:Edge,0-1-8]

LOADING (psf)	SPACING-	2-0-0	CSI.	DEFL.	in (loc)	l/defl	L/d	PLATES	GRIP
TCLL 40.0	Plate Grip DOL	1.00	TC 0.07	Vert(LL)	n/a	-	n/a	MT20	244/190
TCDL 10.0	Lumber DOL	1.00	BC 0.01	Vert(CT)	n/a	-	n/a		
BCLL 0.0	Rep Stress Incr	YES	WB 0.04	Horz(CT)	0.00	13	n/a		
BCDL 5.0	Code IRC2018/TPI2014		Matrix-SH						
								Weight: 68 lb	FT = 0%F, 0%E

LUMBER-
TOP CHORD 2x4 SP No.1(flat)
BOT CHORD 2x4 SP No.1(flat)
WEBS 2x4 SP No.3(flat)
OTHERS 2x4 SP No.3(flat)

BRACING-
TOP CHORD Structural wood sheathing directly applied or 6-0-0 oc purlins, except end verticals.
BOT CHORD Rigid ceiling directly applied or 10-0-0 oc bracing.

REACTIONS. All bearings 14-11-0.
(lb) - Max Grav All reactions 250 lb or less at joint(s) 24, 13, 23, 22, 21, 20, 19, 18, 17, 16, 15, 14

FORCES. (lb) - Max. Comp./Max. Ten. - All forces 250 (lb) or less except when shown.

- NOTES-** (7-8)
- All plates are 1.5x3 MT20 unless otherwise indicated.
 - Gable requires continuous bottom chord bearing.
 - Truss to be fully sheathed from one face or securely braced against lateral movement (i.e. diagonal web).
 - Gable studs spaced at 1-4-0 oc.
 - This truss is designed in accordance with the 2018 International Residential Code sections R502.11.1 and R802.10.2 and referenced standard ANSI/TPI 1.
 - Recommend 2x6 strongbacks, on edge, spaced at 10-0-0 oc and fastened to each truss with 3-10d (0.131" X 3") nails. Strongbacks to be attached to walls at their outer ends or restrained by other means.
 - Graphical web bracing representation does not depict the size, type or the orientation of the brace on the web. Symbol only indicates that the member must be braced.
 - Bearing symbols are only graphical representations of a possible bearing condition. Bearing symbols are not considered in the structural design of the truss to support the loads indicated.

LOAD CASE(S) Standard



12/9/2020

Warning !—Verify design parameters and read notes before use. This design is based only upon parameters shown, and is for an individual building component to be installed and loaded vertically. Applicability of design parameters and proper incorporation of component is responsibility of building designer – not truss designer or truss engineer. Bracing shown is for lateral support of individual web members only. Additional temporary bracing to ensure stability during construction is the responsibility of the erector. Additional permanent bracing of the overall structure is the responsibility of the building designer. For general guidance regarding fabrication, quality control, storage, delivery, erection and bracing, consult ANSI/TPI 1 *National Design Standard for Metal Plate Connected Wood Truss Construction* and BCSI 1-03 *Guide to Good Practice for Handling, Installing & Bracing of Metal Plate Connected Wood Trusses* from Truss Plate Institute, 583 D'Onofrio Drive, Madison, WI 53719.

Job	Truss	Truss Type	Qty	Ply	LOT 1161 CARRIAGE CIRCLE 116 SPRUCE HOLLOW CIRCLE SPRING LAKE, N
20-5717-F02	F03	GABLE	1	1	
Job Reference (optional)					# 24695

8.330 s Mar 10 2020 MiTek Industries, Inc. Thu Dec 10 21:06:55 2020 Page 1
 ID:VaeaK7vWB81xgotwpMaLleyLxWJ-hCGAbZxJPDsfGGgGKwUjfvigRXhEUBCKpAqcPyAGD_

0₁-8

0₁-8

Scale = 1:16.3

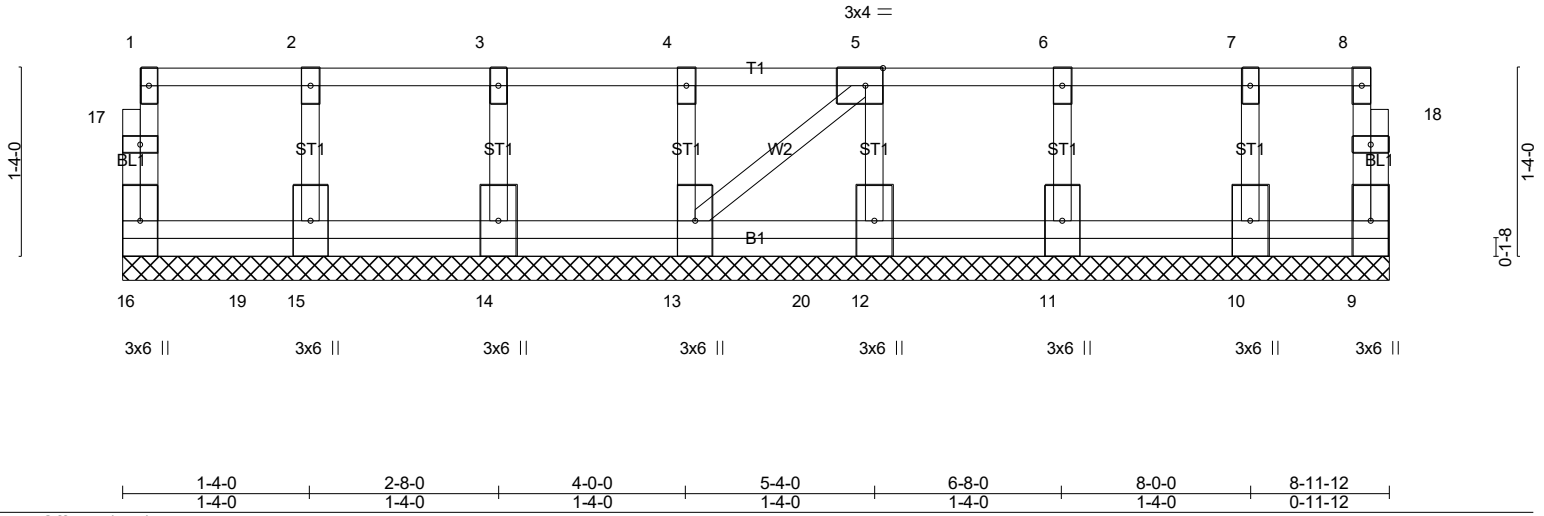

Plate Offsets (X,Y)-- [5:0-1-8,Edge]

LOADING (psf)	SPACING-	2-0-0	CSI.	DEFL.	in	(loc)	l/defl	L/d	PLATES	GRIP
TCLL 40.0	Plate Grip DOL	1.00	TC 0.07	Vert(LL)	n/a	-	n/a	999	MT20	244/190
TCDL 10.0	Lumber DOL	1.00	BC 0.02	Vert(CT)	n/a	-	n/a	999		
BCLL 0.0	Rep Stress Incr	NO	WB 0.03	Horz(CT)	0.00	9	n/a	n/a		
BCDL 5.0	Code IRC2018/TPI2014		Matrix-P						Weight: 56 lb	FT = 0%F, 0%E

LUMBER-
 TOP CHORD 2x4 SP No.1(flat)
 BOT CHORD 2x4 SP No.1(flat)
 WEBS 2x4 SP No.3(flat)
 OTHERS 2x4 SP No.3(flat)

BRACING-
 TOP CHORD Structural wood sheathing directly applied or 6-0-0 oc purlins, except end verticals.
 BOT CHORD Rigid ceiling directly applied or 10-0-0 oc bracing.

REACTIONS. All bearings 8-11-12.
 (lb) - Max Grav All reactions 250 lb or less at joint(s) 16, 9, 15, 14, 13, 12, 11, 10

FORCES. (lb) - Max. Comp./Max. Ten. - All forces 250 (lb) or less except when shown.

- NOTES-** (10-11)
- All plates are 1.5x3 MT20 unless otherwise indicated.
 - Gable requires continuous bottom chord bearing.
 - Truss to be fully sheathed from one face or securely braced against lateral movement (i.e. diagonal web).
 - Gable studs spaced at 1-4-0 oc.
 - This truss is designed in accordance with the 2018 International Residential Code sections R502.11.1 and R802.10.2 and referenced standard ANSI/TPI 1.
 - Load case(s) 1, 2 has/have been modified. Building designer must review loads to verify that they are correct for the intended use of this truss.
 - Recommend 2x6 strongbacks, on edge, spaced at 10-0-0 oc and fastened to each truss with 3-10d (0.131" X 3") nails. Strongbacks to be attached to walls at their outer ends or restrained by other means.
 - Hanger(s) or other connection device(s) shall be provided sufficient to support concentrated load(s) 68 lb down at 0-11-0, 68 lb down at 2-11-0, and 68 lb down at 4-11-0, and 68 lb down at 6-11-0 on bottom chord. The design/selection of such connection device(s) is the responsibility of others.
 - In the LOAD CASE(S) section, loads applied to the face of the truss are noted as front (F) or back (B).
 - Graphical web bracing representation does not depict the size, type or the orientation of the brace on the web. Symbol only indicates that the member must be braced.
 - Bearing symbols are only graphical representations of a possible bearing condition. Bearing symbols are not considered in the structural design of the truss to support the loads indicated.

- LOAD CASE(S)** Standard
- Dead + Floor Live (balanced): Lumber Increase=1.00, Plate Increase=1.00
 Uniform Loads (plf)
 Vert: 9-16=-10, 1-8=-100
 Concentrated Loads (lb)
 Vert: 14=-68(F) 11=-68(F) 19=-68(F) 20=-68(F)
 - Dead: Lumber Increase=1.00, Plate Increase=1.00
 Uniform Loads (plf)
 Vert: 9-16=-10, 1-8=-100



12/9/2020

Continued on Page 2
 Design parameters and read notes before use. This design is based only upon parameters shown, and is for an individual building component to be installed and loaded vertically. Applicability of design parameters and proper incorporation of component is responsibility of building designer – not truss designer or truss engineer. Bracing shown is for lateral support of individual web members only. Additional temporary bracing to ensure stability during construction is the responsibility of the erector. Additional permanent bracing of the overall structure is the responsibility of the building designer. For general guidance regarding fabrication, quality control, storage, delivery, erection and bracing, consult ANSI/TPI 1 National Design Standard for Metal Plate Connected Wood Truss Construction and BCSI 1-03 Guide to Good Practice for Handling, Installing & Bracing of Metal Plate Connected Wood Trusses from Truss Plate Institute, 583 D'Onofrio Drive, Madison, WI 53719.

Job	Truss	Truss Type	Qty	Ply	LOT 1161 CARRIAGE CIRCLE 116 SPRUCE HOLLOW CIRCLE SPRING LAKE, N
20-5717-F02	F03	GABLE	1	1	Job Reference (optional) # 24695

8.330 s Mar 10 2020 MiTek Industries, Inc. Thu Dec 10 21:06:55 2020 Page 2
 ID:VaeaK7vWB81xgotwpMaLleyLxWJ-hCGAbZxJPDsfGGgGKWufvigRXhEUBCkpAqcPyAGD_

LOAD CASE(S) Standard
 Concentrated Loads (lb)
 Vert: 14=-68(F) 11=-68(F) 19=-68(F) 20=-68(F)



12/9/2020

Warning !—Verify design parameters and read notes before use. This design is based only upon parameters shown, and is for an individual building component to be installed and loaded vertically. Applicability of design parameters and proper incorporation of component is responsibility of building designer – not truss designer or truss engineer. Bracing shown is for lateral support of individual web members only. Additional temporary bracing to ensure stability during construction is the responsibility of the erector. Additional permanent bracing of the overall structure is the responsibility of the building designer. For general guidance regarding fabrication, quality control, storage, delivery, erection and bracing, consult ANSI/TPI 1 *National Design Standard for Metal Plate Connected Wood Truss Construction* and BCSI 1-03 *Guide to Good Practice for Handling, Installing & Bracing of Metal Plate Connected Wood Trusses* from Truss Plate Institute, 583 D'Onofrio Drive, Madison, WI 53719.

Job 20-5717-F02	Truss F04	Truss Type Floor	Qty 2	Ply 1	LOT 1161 CARRIAGE CIRCLE 116 SPRUCE HOLLOW CIRCLE SPRING LAKE, N.C. Job Reference (optional) # 24695
--------------------	--------------	---------------------	----------	----------	---------------------------------------------------------------------------------------------------------------------

8.330 s Mar 10 2020 MiTek Industries, Inc. Thu Dec 10 21:06:56 2020 Page 1
ID:Vaeak7WB81xgotwpMaLleyLxWJ-hCGAbZxJPDsfiGGgGKWujfvegRUaES5SckpAqbOyAGD_

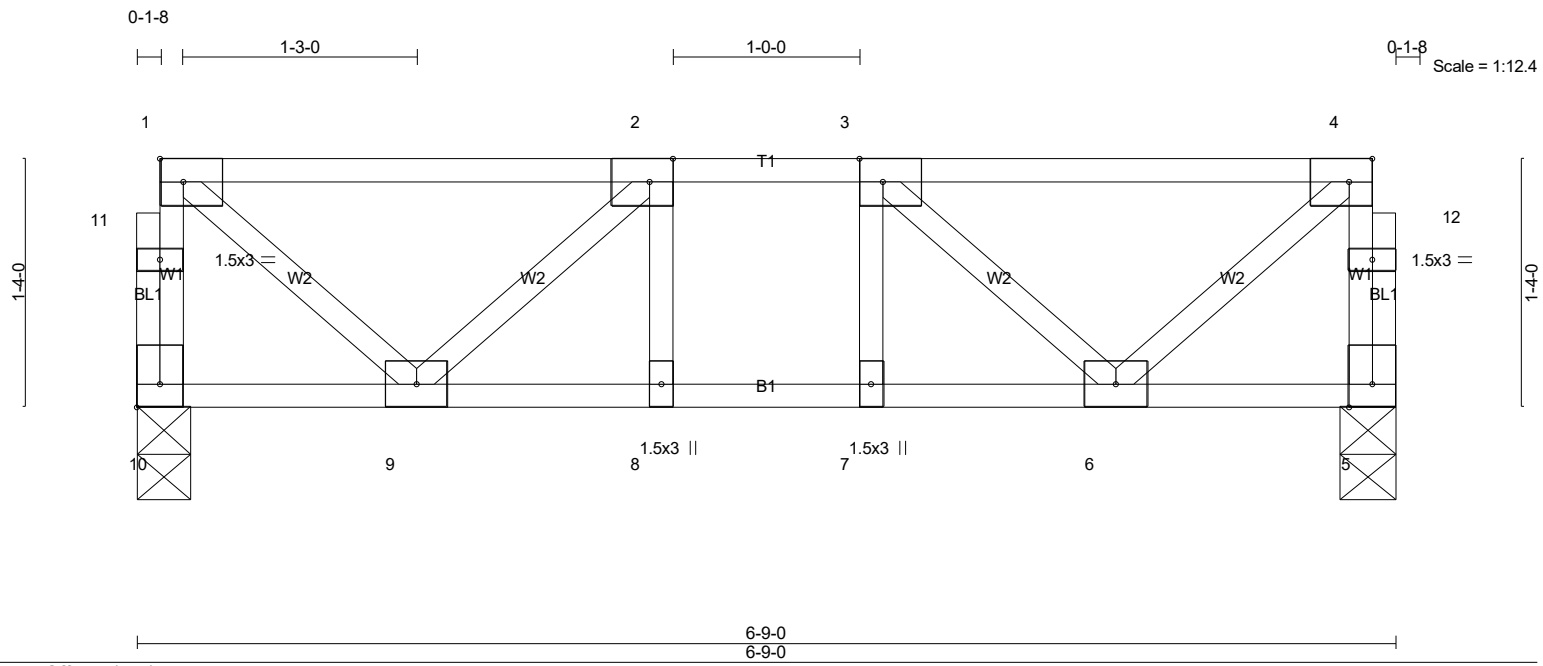

Plate Offsets (X,Y)-- [2:0-1-8,Edge], [3:0-1-8,Edge], [4:0-1-8,Edge], [10:Edge,0-1-8]					
LOADING (psf)	SPACING- 2-0-0	CSI.	DEFL. in (loc) l/defl L/d	PLATES	GRIP
TCLL 40.0	Plate Grip DOL 1.00	TC 0.32	Vert(LL) -0.02 8-9 >999 480	MT20	244/190
TCDL 10.0	Lumber DOL 1.00	BC 0.22	Vert(CT) -0.02 8-9 >999 360		
BCLL 0.0	Rep Stress Incr YES	WB 0.17	Horz(CT) 0.00 5 n/a n/a		
BCDL 5.0	Code IRC2018/TPI2014	Matrix-SH		Weight: 39 lb	FT = 0%F, 0%E

LUMBER-	BRACING-
TOP CHORD 2x4 SP No.1(flat)	TOP CHORD Structural wood sheathing directly applied or 6-0-0 oc purlins, except end verticals.
BOT CHORD 2x4 SP No.1(flat)	BOT CHORD Rigid ceiling directly applied or 10-0-0 oc bracing.
WEBS 2x4 SP No.3(flat)	

REACTIONS. (lb/size) 10=351/0-3-8 (min. 0-1-8), 5=351/0-3-8 (min. 0-1-8)

FORCES. (lb) - Max. Comp./Max. Ten. - All forces 250 (lb) or less except when shown.
TOP CHORD 10-11=-346/0, 1-11=-345/0, 5-12=-346/0, 4-12=-345/0, 1-2=-273/0, 2-3=-510/0, 3-4=-273/0
BOT CHORD 8-9=0/510, 7-8=0/510, 6-7=0/510
WEBS 1-9=0/347, 4-6=0/347, 2-9=-323/0, 3-6=-323/0

- NOTES-** (5-6)
- 1) Unbalanced floor live loads have been considered for this design.
 - 2) All plates are 3x4 MT20 unless otherwise indicated.
 - 3) This truss is designed in accordance with the 2018 International Residential Code sections R502.11.1 and R802.10.2 and referenced standard ANSI/TPI 1.
 - 4) Recommend 2x6 strongbacks, on edge, spaced at 10-0-0 oc and fastened to each truss with 3-10d (0.131" X 3") nails. Strongbacks to be attached to walls at their outer ends or restrained by other means.
 - 5) Graphical web bracing representation does not depict the size, type or the orientation of the brace on the web. Symbol only indicates that the member must be braced.
 - 6) Bearing symbols are only graphical representations of a possible bearing condition. Bearing symbols are not considered in the structural design of the truss to support the loads indicated.

LOAD CASE(S) Standard

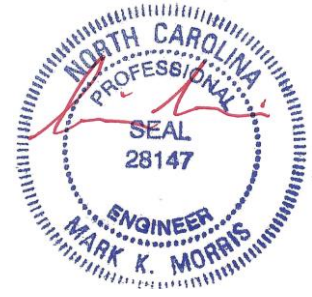

12/9/2020

Warning !—Verify design parameters and read notes before use. This design is based only upon parameters shown, and is for an individual building component to be installed and loaded vertically. Applicability of design parameters and proper incorporation of component is responsibility of building designer – not truss designer or truss engineer. Bracing shown is for lateral support of individual web members only. Additional temporary bracing to ensure stability during construction is the responsibility of the erector. Additional permanent bracing of the overall structure is the responsibility of the building designer. For general guidance regarding fabrication, quality control, storage, delivery, erection and bracing, consult ANSI/TPI 1 *National Design Standard for Metal Plate Connected Wood Truss Construction* and BCSI 1-03 *Guide to Good Practice for Handling, Installing & Bracing of Metal Plate Connected Wood Trusses* from Truss Plate Institute, 583 D*Onofrio Drive, Madison, WI 53719.

Job 20-5717-F02	Truss F06	Truss Type Floor	Qty 1	Ply 1	LOT 1161 CARRIAGE CIRCLE 116 SPRUCE HOLLOW CIRCLE SPRING LAKE, N.C. # 24695
--------------------	--------------	---------------------	----------	----------	----------------------------------------------------------------------------------

8.330 s Mar 10 2020 MiTek Industries, Inc. Thu Dec 10 21:06:57 2020 Page 1
ID:VaeaK7VWB81xgotwpmMaLleyLxWJ-dbOw0FyZxq6MyaQ3OIYMo4_yIEASiLZVB7fwflyAGCy



Scale = 1:12.5

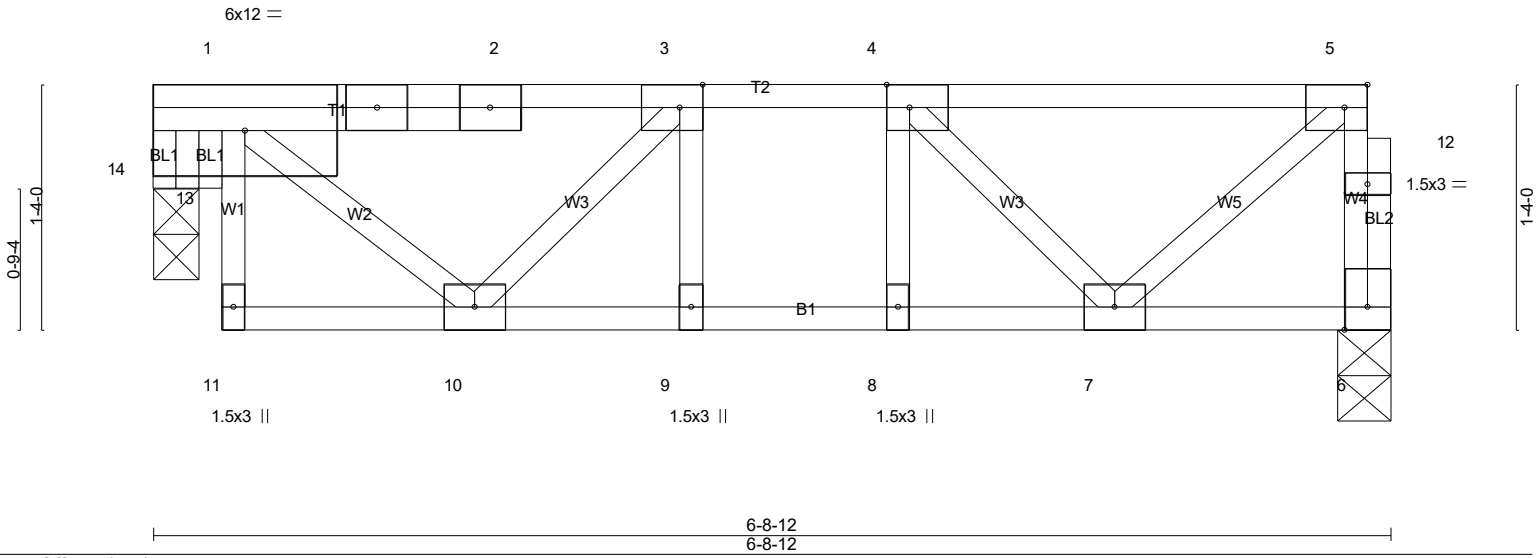

Plate Offsets (X,Y)-- [3:0-1-8,Edge], [4:0-1-8,Edge], [5:0-1-8,Edge], [14:0-0-12,0-1-14]

LOADING (psf)	SPACING-	2-0-0	CSI.	DEFL.	in	(loc)	l/defl	L/d	PLATES	GRIP
TCLL 40.0	Plate Grip DOL	1.00	TC 0.51	Vert(LL)	-0.01	9	>999	480	MT20	244/190
TCDL 10.0	Lumber DOL	1.00	BC 0.19	Vert(CT)	-0.02	9	>999	360		
BCLL 0.0	Rep Stress Incr	YES	WB 0.17	Horz(CT)	0.01	6	n/a	n/a		
BCDL 5.0	Code IRC2018/TPI2014		Matrix-P						Weight: 41 lb	FT = 0%F, 0%E

LUMBER-
TOP CHORD 2x4 SP No.1(flat)
BOT CHORD 2x4 SP No.1(flat)
WEBS 2x4 SP No.3(flat)
OTHERS 2x4 SP No.3(flat)

BRACING-
TOP CHORD Structural wood sheathing directly applied or 6-0-0 oc purlins, except end verticals.
BOT CHORD Rigid ceiling directly applied or 10-0-0 oc bracing.

REACTIONS. (lb/size) 6=346/0-3-8 (min. 0-1-8), 14=326/0-3-0 (min. 0-1-8)

FORCES. (lb) - Max. Comp./Max. Ten. - All forces 250 (lb) or less except when shown.
TOP CHORD 6-12=-341/0, 5-12=-341/0, 1-2=-305/0, 2-3=-301/0, 3-4=-484/0, 4-5=-274/0
BOT CHORD 9-10=0/484, 8-9=0/484, 7-8=0/484
WEBS 1-10=0/304, 5-7=0/349, 3-10=-263/0, 4-7=-301/0, 1-14=-402/0

- NOTES-** (7-8)
- Unbalanced floor live loads have been considered for this design.
 - All plates are 3x4 MT20 unless otherwise indicated.
 - Bearing at joint(s) 14 considers parallel to grain value using ANSI/TPI 1 angle to grain formula. Building designer should verify capacity of bearing surface.
 - This truss is designed in accordance with the 2018 International Residential Code sections R502.11.1 and R802.10.2 and referenced standard ANSI/TPI 1.
 - Recommend 2x6 strongbacks, on edge, spaced at 10-0-0 oc and fastened to each truss with 3-10d (0.131" X 3") nails. Strongbacks to be attached to walls at their outer ends or restrained by other means.
 - CAUTION, Do not erect truss backwards.
 - Graphical web bracing representation does not depict the size, type or the orientation of the brace on the web. Symbol only indicates that the member must be braced.
 - Bearing symbols are only graphical representations of a possible bearing condition. Bearing symbols are not considered in the structural design of the truss to support the loads indicated.

LOAD CASE(S) Standard



12/9/2020

Warning !—Verify design parameters and read notes before use. This design is based only upon parameters shown, and is for an individual building component to be installed and loaded vertically. Applicability of design parameters and proper incorporation of component is responsibility of building designer – not truss designer or truss engineer. Bracing shown is for lateral support of individual web members only. Additional temporary bracing to ensure stability during construction is the responsibility of the erector. Additional permanent bracing of the overall structure is the responsibility of the building designer. For general guidance regarding fabrication, quality control, storage, delivery, erection and bracing, consult ANSI/TPI 1 *National Design Standard for Metal Plate Connected Wood Truss Construction* and BCSI 1-03 *Guide to Good Practice for Handling, Installing & Bracing of Metal Plate Connected Wood Trusses* from Truss Plate Institute, 583 D*Onofrio Drive, Madison, WI 53719.

Job 20-5717-F02	Truss F07	Truss Type Floor Supported Gable	Qty 1	Ply 1	LOT 1161 CARRIAGE CIRCLE 116 SPRUCE HOLLOW CIRCLE SPRING LAKE, N.C. # 24695
--------------------	--------------	-------------------------------------	----------	----------	----------------------------------------------------------------------------------

8.330 s Mar 10 2020 MiTek Industries, Inc. Thu Dec 10 21:06:58 2020 Page 1
ID:Vaeak7vWB81xgotwpMaLleyLxWJ-5nxIEbzBi8EDak?FyS3bLHXcseZcRqieQnOUJkyAGCx

0-1-8

Scale = 1:14.7

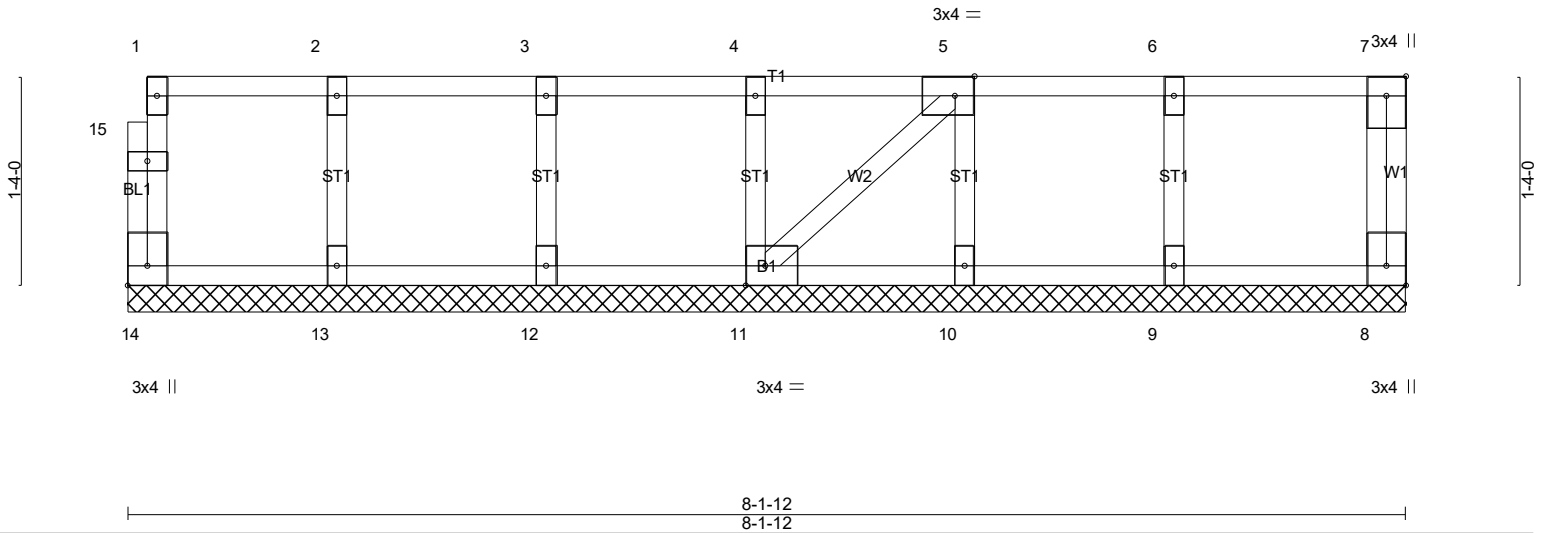

Plate Offsets (X,Y)-- [5:0-1-8,Edge], [8:Edge,0-1-8], [11:0-1-8,Edge], [14:Edge,0-1-8]

LOADING (psf)	SPACING-	CSI.	DEFL.	in	(loc)	l/defl	L/d	PLATES	GRIP
TCLL 40.0	2-0-0	TC 0.07	Vert(LL)	n/a	-	n/a	999	MT20	244/190
TCDL 10.0	Plate Grip DOL 1.00	BC 0.01	Vert(CT)	n/a	-	n/a	999		
BCLL 0.0	Lumber DOL 1.00	WB 0.03	Horz(CT)	0.00	8	n/a	n/a		
BCDL 5.0	Rep Stress Incr YES	Matrix-P							
	Code IRC2018/TPI2014							Weight: 41 lb	FT = 0%F, 0%E

LUMBER-
TOP CHORD 2x4 SP No.1(flat)
BOT CHORD 2x4 SP No.1(flat)
WEBS 2x4 SP No.3(flat)
OTHERS 2x4 SP No.3(flat)

BRACING-
TOP CHORD Structural wood sheathing directly applied or 6-0-0 oc purlins, except end verticals.
BOT CHORD Rigid ceiling directly applied or 10-0-0 oc bracing.

REACTIONS. All bearings 8-1-12.
(lb) - Max Grav All reactions 250 lb or less at joint(s) 14, 8, 13, 12, 11, 10, 9

FORCES. (lb) - Max. Comp./Max. Ten. - All forces 250 (lb) or less except when shown.

- NOTES-** (8-9)
- All plates are 1.5x3 MT20 unless otherwise indicated.
 - Gable requires continuous bottom chord bearing.
 - Truss to be fully sheathed from one face or securely braced against lateral movement (i.e. diagonal web).
 - Gable studs spaced at 1-4-0 oc.
 - This truss is designed in accordance with the 2018 International Residential Code sections R502.11.1 and R802.10.2 and referenced standard ANSI/TPI 1.
 - Recommend 2x6 strongbacks, on edge, spaced at 10-0-0 oc and fastened to each truss with 3-10d (0.131" X 3") nails. Strongbacks to be attached to walls at their outer ends or restrained by other means.
 - CAUTION, Do not erect truss backwards.
 - Graphical web bracing representation does not depict the size, type or the orientation of the brace on the web. Symbol only indicates that the member must be braced.
 - Bearing symbols are only graphical representations of a possible bearing condition. Bearing symbols are not considered in the structural design of the truss to support the loads indicated.

LOAD CASE(S) Standard



12/9/2020

Warning !—Verify design parameters and read notes before use. This design is based only upon parameters shown, and is for an individual building component to be installed and loaded vertically. Applicability of design parameters and proper incorporation of component is responsibility of building designer – not truss designer or truss engineer. Bracing shown is for lateral support of individual web members only. Additional temporary bracing to ensure stability during construction is the responsibility of the erector. Additional permanent bracing of the overall structure is the responsibility of the building designer. For general guidance regarding fabrication, quality control, storage, delivery, erection and bracing, consult ANSI/TPI 1 *National Design Standard for Metal Plate Connected Wood Truss Construction* and BCSI 1-03 *Guide to Good Practice for Handling, Installing & Bracing of Metal Plate Connected Wood Trusses* from Truss Plate Institute, 583 D'Onofrio Drive, Madison, WI 53719.

Job 20-5717-F02	Truss F08	Truss Type Floor Supported Gable	Qty 1	Ply 1	LOT 1161 CARRIAGE CIRCLE 116 SPRUCE HOLLOW CIRCLE SPRING LAKE, N	Job Reference (optional) # 24695
--------------------	--------------	-------------------------------------	----------	----------	--------------------------------------------------------------------	--------------------------------------------

8.330 s Mar 10 2020 MiTek Industries, Inc. Thu Dec 10 21:06:59 2020 Page 1
ID:Vaeak7vWB81xgotwpMaLleyLxWJ-ZzVgRx_qTRM4BuaSV9aqtV4Om2vsAH9ofR81kAyAGCw

Q-1-8

Scale = 1:11.7

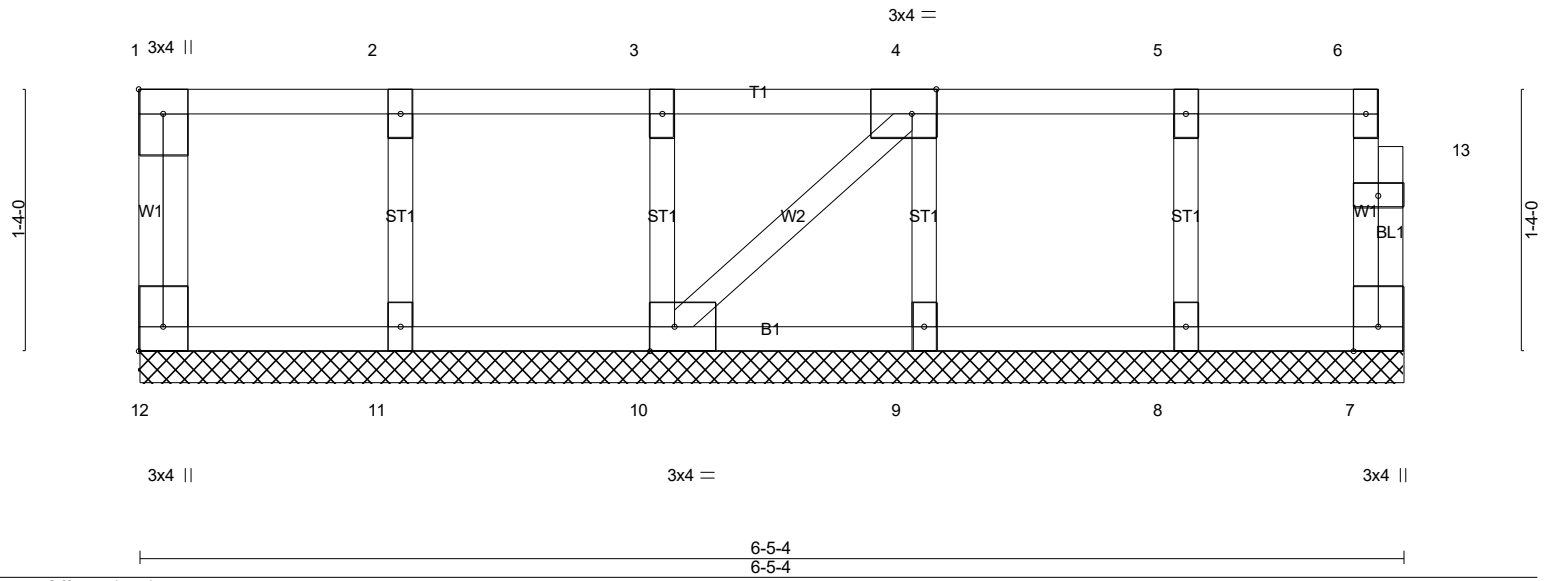

Plate Offsets (X,Y)-- [1:Edge,0-1-8], [4:0-1-8,Edge], [10:0-1-8,Edge], [12:Edge,0-1-8]					
LOADING (psf)	SPACING- 2-0-0	CSI.	DEFL. in (loc) l/defl L/d	PLATES	GRIP
TCLL 40.0	Plate Grip DOL 1.00	TC 0.06	Vert(LL) n/a - n/a 999	MT20	244/190
TCDL 10.0	Lumber DOL 1.00	BC 0.01	Vert(CT) n/a - n/a 999		
BCLL 0.0	Rep Stress Incr YES	WB 0.03	Horz(CT) 0.00 7 n/a n/a		
BCDL 5.0	Code IRC2018/TPI2014	Matrix-P			
				Weight: 34 lb	FT = 0%F, 0%E

LUMBER-
TOP CHORD 2x4 SP No.1(flat)
BOT CHORD 2x4 SP No.1(flat)
WEBS 2x4 SP No.3(flat)
OTHERS 2x4 SP No.3(flat)

BRACING-
TOP CHORD Structural wood sheathing directly applied or 6-0-0 oc purlins, except end verticals.
BOT CHORD Rigid ceiling directly applied or 10-0-0 oc bracing.

REACTIONS. All bearings 6-5-4.
(lb) - Max Grav All reactions 250 lb or less at joint(s) 12, 7, 11, 10, 9, 8

FORCES. (lb) - Max. Comp./Max. Ten. - All forces 250 (lb) or less except when shown.

- NOTES-** (8-9)
- 1) All plates are 1.5x3 MT20 unless otherwise indicated.
 - 2) Gable requires continuous bottom chord bearing.
 - 3) Truss to be fully sheathed from one face or securely braced against lateral movement (i.e. diagonal web).
 - 4) Gable studs spaced at 1-4-0 oc.
 - 5) This truss is designed in accordance with the 2018 International Residential Code sections R502.11.1 and R802.10.2 and referenced standard ANSI/TPI 1.
 - 6) Recommend 2x6 strongbacks, on edge, spaced at 10-0-0 oc and fastened to each truss with 3-10d (0.131" X 3") nails. Strongbacks to be attached to walls at their outer ends or restrained by other means.
 - 7) CAUTION, Do not erect truss backwards.
 - 8) Graphical web bracing representation does not depict the size, type or the orientation of the brace on the web. Symbol only indicates that the member must be braced.
 - 9) Bearing symbols are only graphical representations of a possible bearing condition. Bearing symbols are not considered in the structural design of the truss to support the loads indicated.

LOAD CASE(S) Standard

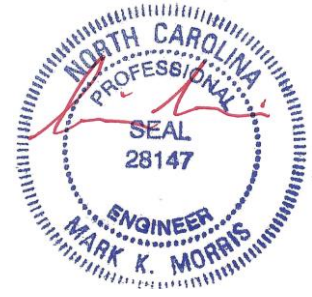

12/9/2020

Warning !—Verify design parameters and read notes before use. This design is based only upon parameters shown, and is for an individual building component to be installed and loaded vertically. Applicability of design parameters and proper incorporation of component is responsibility of building designer – not truss designer or truss engineer. Bracing shown is for lateral support of individual web members only. Additional temporary bracing to ensure stability during construction is the responsibility of the erector. Additional permanent bracing of the overall structure is the responsibility of the building designer. For general guidance regarding fabrication, quality control, storage, delivery, erection and bracing, consult ANSI/TPI 1 *National Design Standard for Metal Plate Connected Wood Truss Construction* and BCSI 1-03 *Guide to Good Practice for Handling, Installing & Bracing of Metal Plate Connected Wood Trusses* from Truss Plate Institute, 583 D*Onofrio Drive, Madison, WI 53719.

Job 20-5717-F02	Truss F09	Truss Type Floor	Qty 3	Ply 1	LOT 1161 CARRIAGE CIRCLE 116 SPRUCE HOLLOW CIRCLE SPRING LAKE, NC	# 24695
--------------------	--------------	---------------------	----------	----------	---------------------------------------------------------------------	---------

8.330 s Mar 10 2020 MiTek Industries, Inc. Thu Dec 10 21:07:00 2020 Page 1
 ID:VaeaK7vWB81xgotwpMaLleyLxWJ-1A32fH_SEIUxp18e3t53QicUYS4vvemxu5tbGdyAGCv

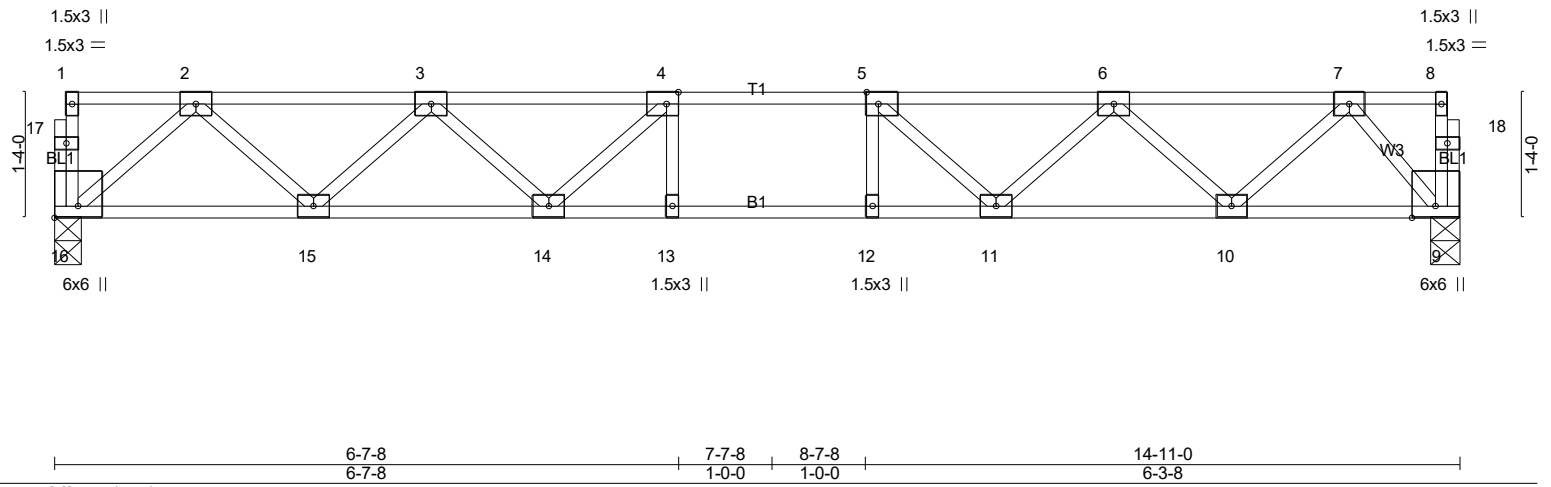
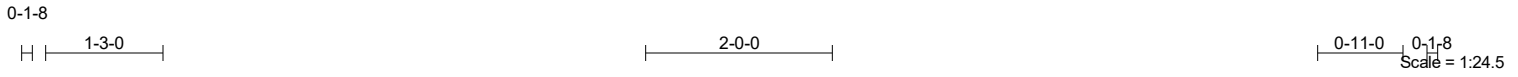

Plate Offsets (X,Y)-- [4:0-1-8,Edge], [5:0-1-8,Edge], [16:Edge,0-3-0]	
LOADING (psf)	SPACING- 2-0-0
TCLL 40.0	Plate Grip DOL 1.00
TCDL 10.0	Lumber DOL 1.00
BCLL 0.0	Rep Stress Incr YES
BCDL 5.0	Code IRC2018/TPI2014
CSI.	DEFL. in (loc) l/defl L/d
TC 0.38	Vert(LL) -0.13 13-14 >999 480
BC 0.72	Vert(CT) -0.17 13-14 >999 360
WB 0.39	Horz(CT) 0.04 9 n/a n/a
Matrix-SH	
PLATES	GRIP
MT20	244/190
Weight: 77 lb FT = 0%F, 0%E	

LUMBER-	BRACING-
TOP CHORD 2x4 SP No.1(flat)	TOP CHORD Structural wood sheathing directly applied or 6-0-0 oc purlins, except end verticals.
BOT CHORD 2x4 SP No.1(flat)	BOT CHORD Rigid ceiling directly applied or 10-0-0 oc bracing.
WEBS 2x4 SP No.3(flat)	

REACTIONS. (lb/size) 16=800/0-3-8 (min. 0-1-8), 9=800/0-3-8 (min. 0-1-8)

FORCES. (lb) - Max. Comp./Max. Ten. - All forces 250 (lb) or less except when shown.
 TOP CHORD 2-3=-1415/0, 3-4=-2194/0, 4-5=-2424/0, 5-6=-2124/0, 6-7=-1266/0
 BOT CHORD 15-16=0/855, 14-15=0/1945, 13-14=0/2424, 12-13=0/2424, 11-12=0/2424, 10-11=0/1830, 9-10=0/672
 WEBS 4-14=-489/0, 3-14=0/406, 3-15=-738/0, 2-15=0/778, 2-16=-1136/0, 5-11=-555/0, 6-11=0/449, 6-10=-785/0, 7-10=0/826, 7-9=-1029/0

- NOTES-** (5-6)
- Unbalanced floor live loads have been considered for this design.
 - All plates are 3x4 MT20 unless otherwise indicated.
 - This truss is designed in accordance with the 2018 International Residential Code sections R502.11.1 and R802.10.2 and referenced standard ANSI/TPI 1.
 - Recommend 2x6 strongbacks, on edge, spaced at 10-0-0 oc and fastened to each truss with 3-10d (0.131" X 3") nails. Strongbacks to be attached to walls at their outer ends or restrained by other means.
 - Graphical web bracing representation does not depict the size, type or the orientation of the brace on the web. Symbol only indicates that the member must be braced.
 - Bearing symbols are only graphical representations of a possible bearing condition. Bearing symbols are not considered in the structural design of the truss to support the loads indicated.

LOAD CASE(S) Standard

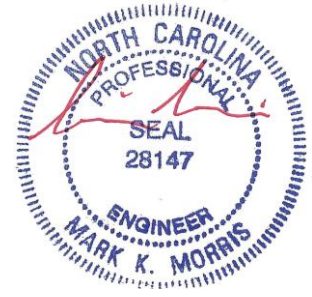

12/9/2020

Warning !—Verify design parameters and read notes before use. This design is based only upon parameters shown, and is for an individual building component to be installed and loaded vertically. Applicability of design parameters and proper incorporation of component is responsibility of building designer – not truss designer or truss engineer. Bracing shown is for lateral support of individual web members only. Additional temporary bracing to ensure stability during construction is the responsibility of the erector. Additional permanent bracing of the overall structure is the responsibility of the building designer. For general guidance regarding fabrication, quality control, storage, delivery, erection and bracing, consult ANSI/TPI 1 *National Design Standard for Metal Plate Connected Wood Truss Construction* and BCSI 1-03 *Guide to Good Practice for Handling, Installing & Bracing of Metal Plate Connected Wood Trusses* from Truss Plate Institute, 583 D'Onofrio Drive, Madison, WI 53719.