

RE: J1220-5726
Weaver / ⁶⁹ Thomas Farm / Harnett

Trenco
818 Soundside Rd
Edenton, NC 27932

Site Information:

Customer: Project Name: J1220-5726
Lot/Block: Model:
Address: Subdivision:
City: State:

General Truss Engineering Criteria & Design Loads (Individual Truss Design Drawings Show Special Loading Conditions):

Design Code: IRC2015/TPI2014 Design Program: MiTek 20/20 8.3
Wind Code: ASCE 7-10 Wind Speed: 130 mph
Roof Load: 40.0 psf Floor Load: N/A psf

This package includes 7 individual, dated Truss Design Drawings and 0 Additional Drawings.

No.	Seal#	Truss Name	Date
1	E14688948	A1	12/24/2020
2	E14688949	A1GE	12/24/2020
3	E14688950	A2	12/24/2020
4	E14688951	B1	12/24/2020
5	E14688952	B1GE	12/24/2020
6	E14688953	P1	12/24/2020
7	E14688954	P1GE	12/24/2020

The truss drawing(s) referenced above have been prepared by Truss Engineering Co. under my direct supervision based on the parameters provided by Comtech, Inc - Fayetteville.
Truss Design Engineer's Name: Gilbert, Eric
My license renewal date for the state of North Carolina is December 31, 2020.
North Carolina COA: C-0844

IMPORTANT NOTE: The seal on these truss component designs is a certification that the engineer named is licensed in the jurisdiction(s) identified and that the designs comply with ANSI/TPI 1. These designs are based upon parameters shown (e.g., loads, supports, dimensions, shapes and design codes), which were given to TRENCO. Any project specific information included is for TRENCO customers file reference purpose only, and was not taken into account in the preparation of these designs. TRENCO has not independently verified the applicability of the design parameters or the designs for any particular building. Before use, the building designer should verify applicability of design parameters and properly incorporate these designs into the overall building design per ANSI/TPI 1, Chapter 2.

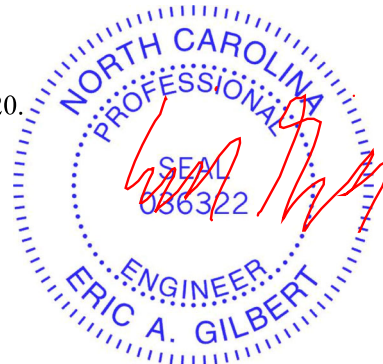

Job	Truss	Truss Type	Qty	Ply	Weaver /69 Thomas Farm / Harnett	E14688948
J1220-5726	A1	FINK	9	1	Job Reference (optional)	

Comtech, Inc. Fayetteville, NC - 28314,

8.330 s May 6 2020 MiTek Industries, Inc. Fri Jul 31 14:41:55 2020 Page 1

ID:lwPOH6hK8Jep6t6SXqQOJcym6C-5k_Pckn6a?f4xzZbJ9TKn0WsnADfyFgtpA5waysWPw

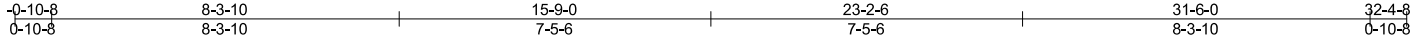

Scale = 1:55.0

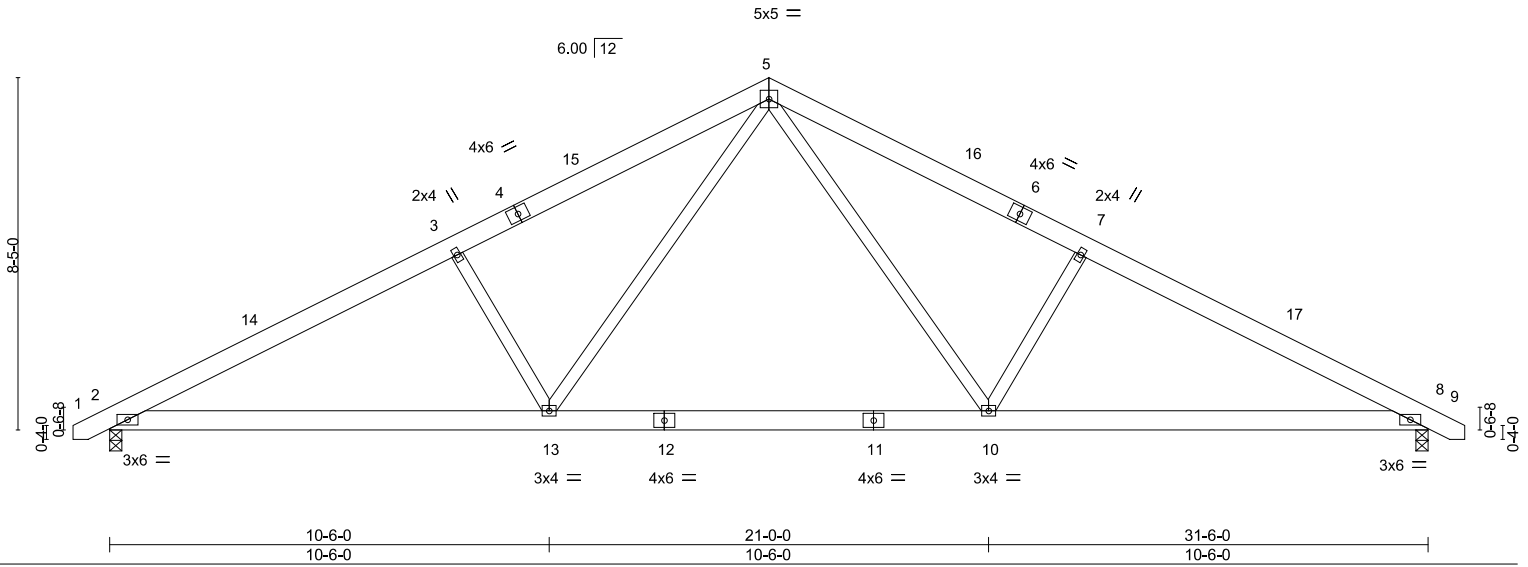

LOADING (psf)	SPACING-	CSI.	DEFL.	PLATES	GRIP
TCLL 20.0	2-0-0	TC 0.28	in (loc) l/defl L/d	MT20	244/190
TCDL 10.0	Plate Grip DOL 1.15	BC 0.48	Vert(LL) -0.20 10-13 >999 360		
BCLL 0.0 *	Lumber DOL 1.15	WB 0.23	Vert(CT) -0.29 10-13 >999 240		
BCDL 10.0	Rep Stress Incr YES	Matrix-S	Horz(CT) 0.05 8 n/a n/a		
	Code IRC2015/TPI2014		Wind(LL) 0.05 2-13 >999 240	Weight: 201 lb	FT = 20%

LUMBER-

TOP CHORD 2x6 SP No.1
BOT CHORD 2x6 SP No.1
WEBS 2x4 SP No.2

BRACING-

TOP CHORD Structural wood sheathing directly applied or 4-11-8 oc purlins.
BOT CHORD Rigid ceiling directly applied or 10-0-0 oc bracing.

REACTIONS.

(size) 2=0-3-8, 8=0-3-8
Max Horz 2=107(LC 11)
Max Uplift 2=-87(LC 12), 8=-87(LC 13)
Max Grav 2=1299(LC 1), 8=1299(LC 1)

FORCES. (lb) - Max. Comp./Max. Ten. - All forces 250 (lb) or less except when shown.

TOP CHORD 2-3=-2188/486, 3-5=-1990/517, 5-7=-1990/517, 7-8=-2188/486
BOT CHORD 2-13=-311/1914, 10-13=-102/1258, 8-10=-320/1873
WEBS 3-13=-466/285, 5-13=-144/843, 5-10=-144/843, 7-10=-466/285

NOTES-

- Unbalanced roof live loads have been considered for this design.
- Wind: ASCE 7-10; Vult=130mph (3-second gust) Vasd=103mph; TCDL=6.0psf; BCDL=6.0psf; h=15ft; Cat. II; Exp C; Enclosed; MWFRS (envelope) and C-C Exterior(2) -0-8-6 to 3-8-7, Interior(1) 3-8-7 to 15-9-0, Exterior(2) 15-9-0 to 20-1-13, Interior(1) 20-1-13 to 32-2-6 zone; C-C for members and forces & MWFRS for reactions shown; Lumber DOL=1.60 plate grip DOL=1.60
- This truss has been designed for a 10.0 psf bottom chord live load nonconcurrent with any other live loads.
- * This truss has been designed for a live load of 30.0psf on the bottom chord in all areas where a rectangle 3-6-0 tall by 2-0-0 wide will fit between the bottom chord and any other members, with BCDL = 10.0psf.
- Provide mechanical connection (by others) of truss to bearing plate capable of withstanding 100 lb uplift at joint(s) 2, 8.



July 31, 2020

WARNING - Verify design parameters and READ NOTES ON THIS AND INCLUDED MITEK REFERENCE PAGE MII-7473 rev. 5/19/2020 BEFORE USE.

Design valid for use only with MiTek® connectors. This design is based only upon parameters shown, and is for an individual building component, not a truss system. Before use, the building designer must verify the applicability of design parameters and properly incorporate this design into the overall building design. Bracing indicated is to prevent buckling of individual truss web and/or chord members only. Additional temporary and permanent bracing is always required for stability and to prevent collapse with possible personal injury and property damage. For general guidance regarding the fabrication, storage, delivery, erection and bracing of trusses and truss systems, see **ANSI/TPI1 Quality Criteria, DSB-89 and BCSI Building Component Safety Information** available from Truss Plate Institute, 2670 Crain Highway, Suite 203 Waldorf, MD 20601



818 Soundside Road
Edenton, NC 27932

Job	Truss	Truss Type	Qty	Ply	Weaver / 69 Thomas Farm / Harnett	E14688949
J1220-5726	A1GE	GABLE	2	1	Job Reference (optional)	

Comtech, Inc. Fayetteville, NC - 28314,

8.330 s May 6 2020 MiTek Industries, Inc. Fri Jul 31 14:41:58 2020 Page 1

ID:lwPOH6hK8Jeptt6SXqQOJcyzm6C-VJgXEmp?tw1foQHA_IGAyQe5j?17skH6ZnPIXvysWPT

0-10-8 15-9-0 31-6-0 32-4-8
0-10-8 15-9-0 15-9-0 0-10-8

Scale = 1:58.0

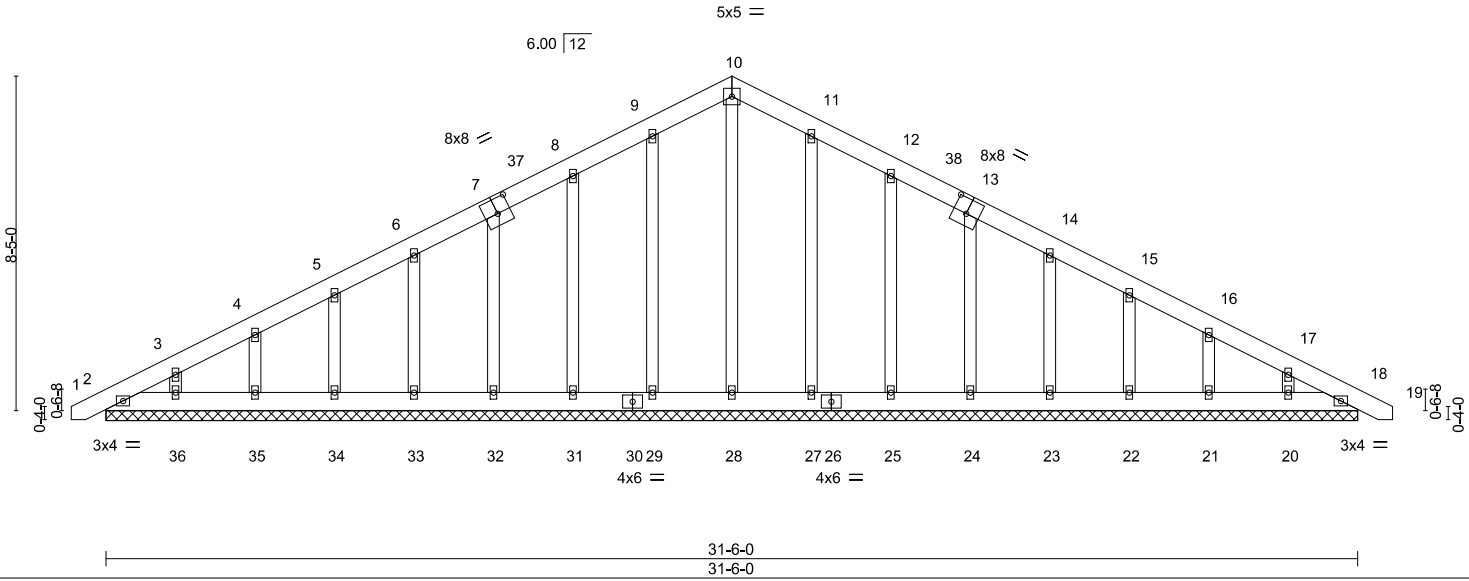

Plate Offsets (X,Y)-- [7:0-4-0,0-4-8], [13:0-4-0,0-4-8]

LOADING (psf)	SPACING-	CSL	DEFL.	in (loc)	l/defl	L/d	PLATES	GRIP
TCLL 20.0	Plate Grip DOL 1.15	TC 0.05	Vert(LL)	0.00	18	n/r	MT20	244/190
TCDL 10.0	Lumber DOL 1.15	BC 0.02	Vert(CT)	0.00	18	n/r		
BCLL 0.0 *	Rep Stress Incr YES	WB 0.14	Horz(CT)	0.00	18	n/a		
BCDL 10.0	Code IRC2015/TPI2014	Matrix-S						
							Weight: 246 lb	FT = 20%

LUMBER-
TOP CHORD 2x6 SP No.1
BOT CHORD 2x6 SP No.1
OTHERS 2x4 SP No.2

BRACING-
TOP CHORD Structural wood sheathing directly applied or 6'-0" oc purlins.
BOT CHORD Rigid ceiling directly applied or 10'-0" oc bracing.

REACTIONS. All bearings 31-6-0.
(lb) - Max Horz 2=166(LC 16)
Max Uplift All uplift 100 lb or less at joint(s) 2, 18, 29, 31, 32, 33, 34, 35, 36, 27, 25, 24, 23, 22, 21, 20
Max Grav All reactions 250 lb or less at joint(s) 2, 18, 28, 29, 31, 32, 33, 34, 35, 36, 27, 25, 24, 23, 22, 21, 20

FORCES. (lb) - Max. Comp./Max. Ten. - All forces 250 (lb) or less except when shown.
TOP CHORD 8-9=-94/277, 9-10=-110/321, 10-11=-110/323, 11-12=-94/280

- NOTES-**
- Unbalanced roof live loads have been considered for this design.
 - Wind: ASCE 7-10; Vult=130mph (3-second gust) Vasd=103mph; TC DL=6.0psf; BCDL=6.0psf; h=15ft; Cat. II; Exp C; Enclosed; MWFRS (envelope) gable end zone and C-C Corner(3) 0-8-6 to 3-9-0, Exterior(2) 3-9-0 to 15-9-0, Corner(3) 15-9-0 to 20-1-13, Exterior(2) 20-1-13 to 32-2-6 zone; C-C for members and forces & MWFRS for reactions shown; Lumber DOL=1.60 plate grip DOL=1.60
 - Truss designed for wind loads in the plane of the truss only. For studs exposed to wind (normal to the face), see Standard Industry Gable End Details as applicable, or consult qualified building designer as per ANSI/TPI 1.
 - All plates are 2x4 MT20 unless otherwise indicated.
 - Gable requires continuous bottom chord bearing.
 - Gable studs spaced at 2'-0" oc.
 - This truss has been designed for a 10.0 psf bottom chord live load nonconcurrent with any other live loads.
 - * This truss has been designed for a live load of 30.0psf on the bottom chord in all areas where a rectangle 3'-6" tall by 2'-0" wide will fit between the bottom chord and any other members.
 - Provide mechanical connection (by others) of truss to bearing plate capable of withstanding 100 lb uplift at joint(s) 2, 18, 29, 31, 32, 33, 34, 35, 36, 27, 25, 24, 23, 22, 21, 20.

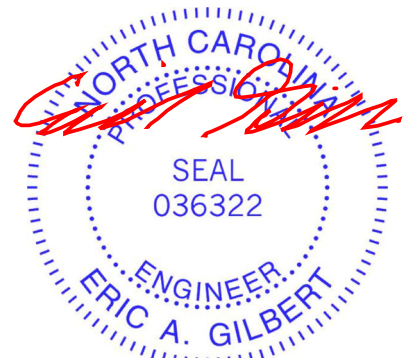

July 31, 2020

WARNING - Verify design parameters and READ NOTES ON THIS AND INCLUDED MITEK REFERENCE PAGE MII-7473 rev. 5/19/2020 BEFORE USE.

Design valid for use only with MiTek® connectors. This design is based only upon parameters shown, and is for an individual building component, not a truss system. Before use, the building designer must verify the applicability of design parameters and properly incorporate this design into the overall building design. Bracing indicated is to prevent buckling of individual truss web and/or chord members only. Additional temporary and permanent bracing is always required for stability and to prevent collapse with possible personal injury and property damage. For general guidance regarding the fabrication, storage, delivery, erection and bracing of trusses and truss systems, see **ANSI/TPI1 Quality Criteria, DSB-89 and BCSI Building Component Safety Information** available from Truss Plate Institute, 2670 Crain Highway, Suite 203 Waldorf, MD 20601



818 Soundside Road
Edenton, NC 27932

Job	Truss	Truss Type	Qty	Ply	Weaver / 69 Thomas Farm / Harnett	E14688950
J1220-5726	A2	ROOF SPECIAL	4	1	Job Reference (optional)	

Comtech, Inc. Fayetteville, NC - 28314,

8.330 s May 6 2020 MiTek Industries, Inc. Fri Jul 31 14:41:59 2020 Page 1

ID:lwPOH6hK8Jeptt6SXqQOJcym6C_VEvR6qdeE9WPasMY?oPVdBDSFPVybsFnR8I3LysWPs

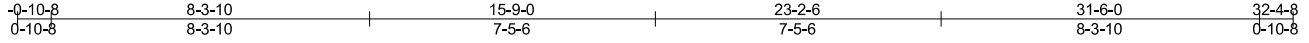

Scale = 1:60.1

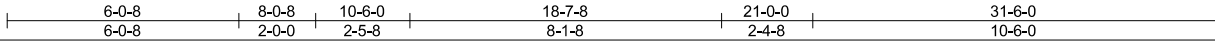
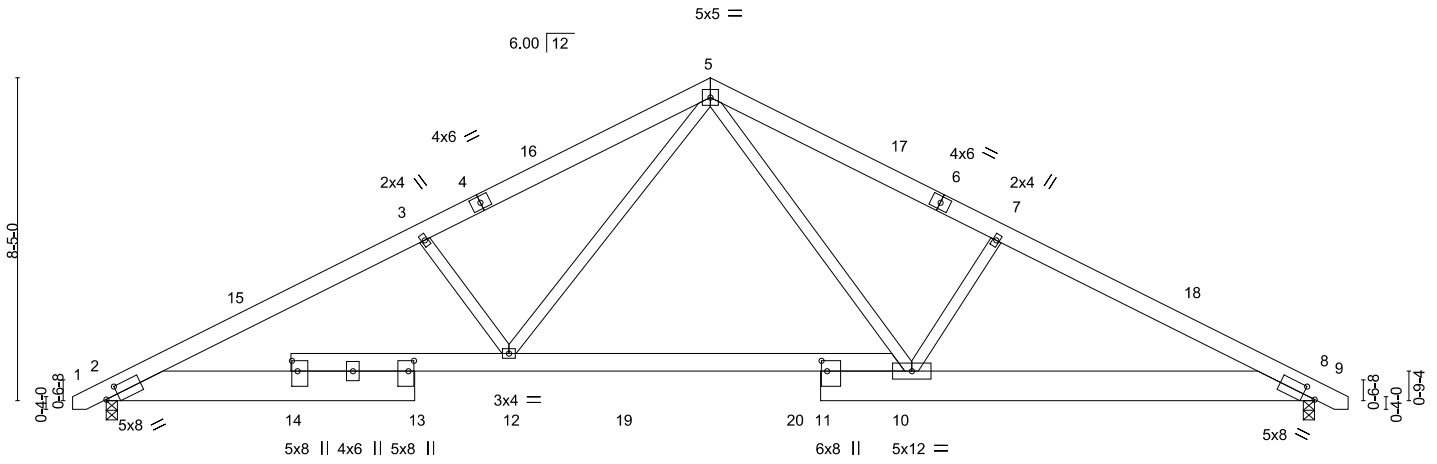

Plate Offsets (X,Y)-- [2:0-3-15,0-2-10], [8:0-3-15,0-2-10], [11:0-3-4,0-1-12], [13:0-3-4,0-1-12], [14:0-3-4,0-1-12]

LOADING (psf)	SPACING-	2-0-0	CSI.	DEFL.	in (loc)	l/defl	L/d	PLATES	GRIP
TCLL 20.0	Plate Grip DOL	1.15	TC 0.24	Vert(LL)	-0.17 10-12	>999	360	MT20	244/190
TCDL 10.0	Lumber DOL	1.15	BC 0.62	Vert(CT)	-0.28 10-12	>999	240		
BCLL 0.0 *	Rep Stress Incr	YES	WB 0.25	Horz(CT)	0.06 8	n/a	n/a		
BCDL 10.0	Code	IRC2015/TPI2014	Matrix-S	Wind(LL)	0.06 10-12	>999	240	Weight: 244 lb	FT = 20%

LUMBER-

TOP CHORD 2x6 SP No.1
 BOT CHORD 2x10 SP No.1 *Except*
 10-14: 2x6 SP No.1
 WEBS 2x4 SP No.2

BRACING-

TOP CHORD Structural wood sheathing directly applied or 4-8-15 oc purlins.
 BOT CHORD Rigid ceiling directly applied or 10-0-0 oc bracing.

REACTIONS.

(size) 2=0-3-8, 8=0-3-8
 Max Horz 2=107(LC 11)
 Max Uplift 2=-88(LC 12), 8=-88(LC 13)
 Max Grav 2=1299(LC 1), 8=1299(LC 1)

FORCES. (lb) - Max. Comp./Max. Ten. - All forces 250 (lb) or less except when shown.

TOP CHORD 2-3=-2535/552, 3-5=-2263/555, 5-7=-2167/507, 7-8=-2403/507
 BOT CHORD 2-12=-363/2197, 10-12=-123/1378, 8-10=-344/2077
 WEBS 5-12=-183/1008, 5-10=-120/928, 7-10=-468/286, 3-12=-460/283

NOTES-

- Unbalanced roof live loads have been considered for this design.
- Wind: ASCE 7-10; Vult=130mph (3-second gust) Vasd=103mph; TC DL=6.0psf; BCDL=6.0psf; h=15ft; Cat. II; Exp C; Enclosed; MWFRS (envelope) and C-C Exterior(2) -0-8-6 to 3-8-7, Interior(1) 3-8-7 to 15-9-0, Exterior(2) 15-9-0 to 20-1-13, Interior(1) 20-1-13 to 32-2-6 zone; C-C for members and forces & MWFRS for reactions shown; Lumber DOL=1.60 plate grip DOL=1.60
- This truss has been designed for a 10.0 psf bottom chord live load nonconcurrent with any other live loads.
- * This truss has been designed for a live load of 30.0psf on the bottom chord in all areas where a rectangle 3-6-0 tall by 2-0-0 wide will fit between the bottom chord and any other members, with BCDL = 10.0psf.
- Provide mechanical connection (by others) of truss to bearing plate capable of withstanding 100 lb uplift at joint(s) 2, 8.



July 31, 2020

WARNING - Verify design parameters and READ NOTES ON THIS AND INCLUDED MITEK REFERENCE PAGE MII-7473 rev. 5/19/2020 BEFORE USE.

Design valid for use only with MiTek® connectors. This design is based only upon parameters shown, and is for an individual building component, not a truss system. Before use, the building designer must verify the applicability of design parameters and properly incorporate this design into the overall building design. Bracing indicated is to prevent buckling of individual truss web and/or chord members only. Additional temporary and permanent bracing is always required for stability and to prevent collapse with possible personal injury and property damage. For general guidance regarding the fabrication, storage, delivery, erection and bracing of trusses and truss systems, see **ANSI/TPI1 Quality Criteria, DSB-89 and BCSI Building Component Safety Information** available from Truss Plate Institute, 2670 Crain Highway, Suite 203 Waldorf, MD 20601



818 Soundside Road
 Edenton, NC 27932

Job	Truss	Truss Type	Qty	Ply	Weaver / 69 Thomas Farm / Harnett	E14688951
J1220-5726	B1	COMMON	3	1		

Comtech, Inc., Fayetteville, NC - 28314,

8.330 s May 6 2020 MiTek Industries, Inc. Fri Jul 31 14:42:00 2020 Page 1

ID:lwPOH6hK8Jeptt6SXqQJcyzm6C-ShnHfSrFPXHN1kRZ6Ije1rkPmoz5K8aP05usboysWPr



5x5 =

Scale = 1:40.4

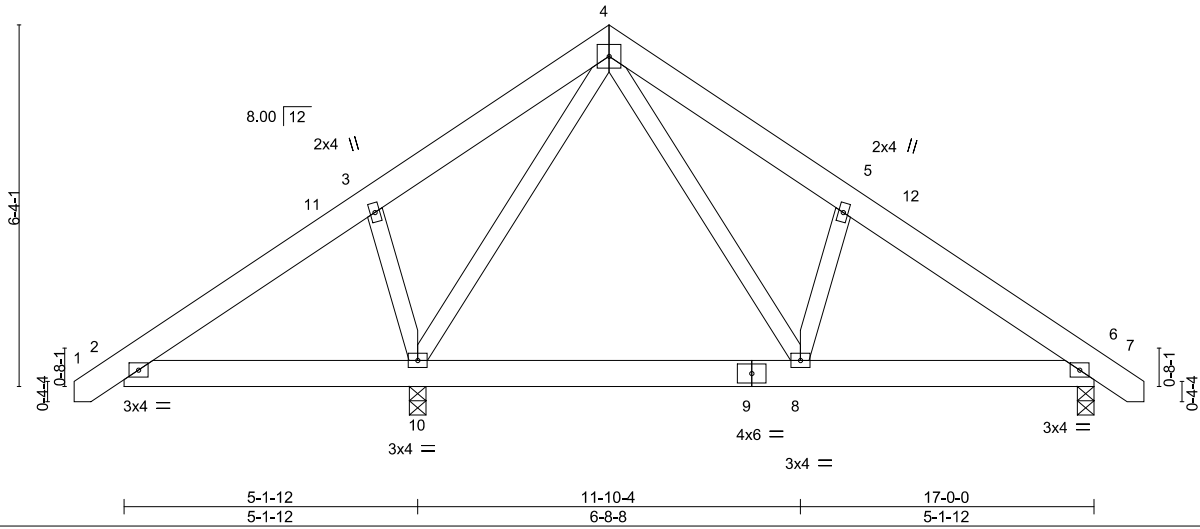

LOADING (psf)	SPACING-	CSI.	DEFL.	in	(loc)	l/defl	L/d	PLATES	GRIP
TCLL 20.0	2-0-0	TC 0.14	Vert(LL)	-0.01	8-10	>999	360	MT20	244/190
TCDL 10.0	Plate Grip DOL 1.15	BC 0.11	Vert(CT)	-0.02	8-10	>999	240		
BCLL 0.0 *	Lumber DOL 1.15	WB 0.54	Horz(CT)	0.00	6	n/a	n/a		
BCDL 10.0	Rep Stress Incr YES	Matrix-S	Wind(LL)	-0.01	8-10	>999	240		
	Code IRC2015/TPI2014							Weight: 120 lb	FT = 20%

LUMBER-

TOP CHORD 2x6 SP No.1
 BOT CHORD 2x6 SP No.1
 WEBS 2x4 SP No.2

BRACING-

TOP CHORD Structural wood sheathing directly applied or 6-0-0 oc purlins.
 BOT CHORD Rigid ceiling directly applied or 6-0-0 oc bracing.

REACTIONS.

(size) 10=0-3-8, 6=0-3-8
 Max Horz 10=-147(LC 10)
 Max Uplift 10=-66(LC 12), 6=-43(LC 13)
 Max Grav 10=1033(LC 1), 6=451(LC 24)

FORCES. (lb) - Max. Comp./Max. Ten. - All forces 250 (lb) or less except when shown.

TOP CHORD 2-3=-371/395, 3-4=-269/441, 4-5=-465/125, 5-6=-488/47
 BOT CHORD 2-10=-264/368, 6-8=0/341
 WEBS 3-10=-327/231, 4-10=-707/371, 4-8=-109/465, 5-8=-288/202

NOTES-

- Unbalanced roof live loads have been considered for this design.
- Wind: ASCE 7-10; Vult=130mph (3-second gust) Vasd=103mph; TCDL=6.0psf; BCDL=6.0psf; h=15ft; Cat. II; Exp C; Enclosed; MWFRS (envelope) and C-C Exterior(2) -0-8-12 to 3-8-1, Interior(1) 3-8-1 to 8-6-0, Exterior(2) 8-6-0 to 12-8-1, Interior(1) 12-8-1 to 17-8-12 zone; cantilever left exposed ;C-C for members and forces & MWFRS for reactions shown; Lumber DOL=1.60 plate grip DOL=1.60
- This truss has been designed for a 10.0 psf bottom chord live load nonconcurrent with any other live loads.
- * This truss has been designed for a live load of 30.0psf on the bottom chord in all areas where a rectangle 3-6-0 tall by 2-0-0 wide will fit between the bottom chord and any other members.
- Provide mechanical connection (by others) of truss to bearing plate capable of withstanding 100 lb uplift at joint(s) 10, 6.



July 31, 2020

WARNING - Verify design parameters and READ NOTES ON THIS AND INCLUDED MITEK REFERENCE PAGE MII-7473 rev. 5/19/2020 BEFORE USE.

Design valid for use only with MiTek® connectors. This design is based only upon parameters shown, and is for an individual building component, not a truss system. Before use, the building designer must verify the applicability of design parameters and properly incorporate this design into the overall building design. Bracing indicated is to prevent buckling of individual truss web and/or chord members only. Additional temporary and permanent bracing is always required for stability and to prevent collapse with possible personal injury and property damage. For general guidance regarding the fabrication, storage, delivery, erection and bracing of trusses and truss systems, see **ANSI/TPI1 Quality Criteria, DSB-89 and BCSI Building Component Safety Information** available from Truss Plate Institute, 2670 Crain Highway, Suite 203 Waldorf, MD 20601



818 Soundside Road
 Edenton, NC 27932

Job	Truss	Truss Type	Qty	Ply	Weaver / 69Thomas Farm / Harnett	E14688952
J1220-5726	B1GE	GABLE	1	1	Job Reference (optional)	

Comtech, Inc., Fayetteville, NC - 28314,

8.330 s May 6 2020 MiTek Industries, Inc. Fri Jul 31 14:42:01 2020 Page 1
 ID:IwPOH6hK8Jeptt6SXqQOJcyzm6C-wuLgsort9rPEfu0lgQqta2GcJCKn3jkYFIdP8EysWPq

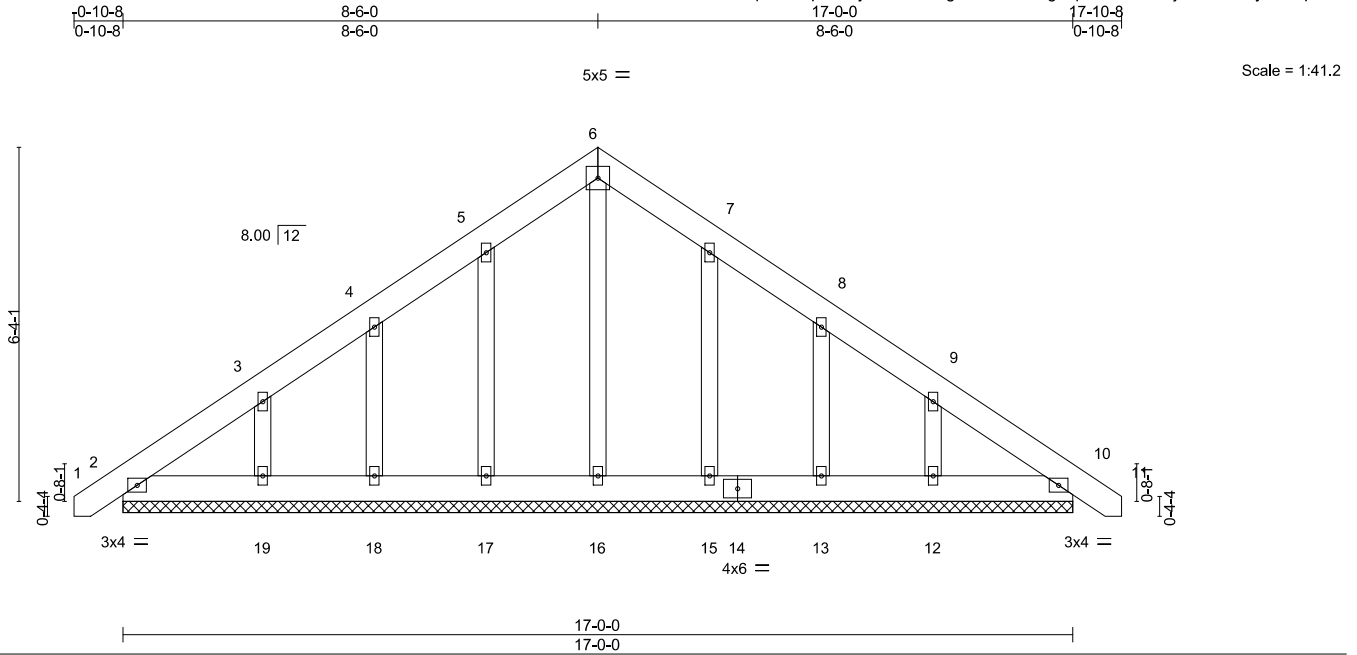

LOADING (psf)	SPACING-	CSI.	DEFL.	PLATES	GRIP
TCLL 20.0	2-0-0	TC 0.02	in (loc) l/defl L/d	MT20	244/190
TCDL 10.0	Plate Grip DOL 1.15	BC 0.02	Vert(LL) 0.00 10 n/r 120		
BCLL 0.0 *	Lumber DOL 1.15	WB 0.06	Vert(CT) 0.00 10 n/r 120		
BCDL 10.0	Rep Stress Incr YES	Matrix-S	Horz(CT) 0.00 10 n/a n/a		
	Code IRC2015/TPI2014			Weight: 126 lb	FT = 20%

LUMBER-

TOP CHORD 2x6 SP No.1
 BOT CHORD 2x6 SP No.1
 OTHERS 2x4 SP No.2

BRACING-

TOP CHORD Structural wood sheathing directly applied or 6-0-0 oc purlins.
 BOT CHORD Rigid ceiling directly applied or 10-0-0 oc bracing.

REACTIONS.

All bearings 17-0-0.
 (lb) - Max Horz 2=-184(LC 10)
 Max Uplift All uplift 100 lb or less at joint(s) 2, 17, 18, 15, 13 except 19=-119(LC 12), 12=-116(LC 13)
 Max Grav All reactions 250 lb or less at joint(s) 2, 10, 16, 17, 18, 19, 15, 13, 12

FORCES. (lb) - Max. Comp./Max. Ten. - All forces 250 (lb) or less except when shown.

NOTES-

- Unbalanced roof live loads have been considered for this design.
- Wind: ASCE 7-10; Vult=130mph (3-second gust) Vasd=103mph; TCDL=6.0psf; BCDL=6.0psf; h=15ft; Cat. II; Exp C; Enclosed; MWFRS (envelope) gable end zone and C-C Corner(3) 0-8-12 to 3-8-1, Exterior(2) 3-8-1 to 8-6-0, Corner(3) 8-6-0 to 12-10-13, Exterior(2) 12-10-13 to 17-8-12 zone;C-C for members and forces & MWFRS for reactions shown; Lumber DOL=1.60 plate grip DOL=1.60
- Truss designed for wind loads in the plane of the truss only. For studs exposed to wind (normal to the face), see Standard Industry Gable End Details as applicable, or consult qualified building designer as per ANSI/TPI 1.
- All plates are 2x4 MT20 unless otherwise indicated.
- Gable requires continuous bottom chord bearing.
- Gable studs spaced at 2-0-0 oc.
- This truss has been designed for a 10.0 psf bottom chord live load nonconcurrent with any other live loads.
- * This truss has been designed for a live load of 30.0psf on the bottom chord in all areas where a rectangle 3-6-0 tall by 2-0-0 wide will fit between the bottom chord and any other members.
- Provide mechanical connection (by others) of truss to bearing plate capable of withstanding 100 lb uplift at joint(s) 2, 17, 18, 15, 13 except (jt=lb) 19=119, 12=116.

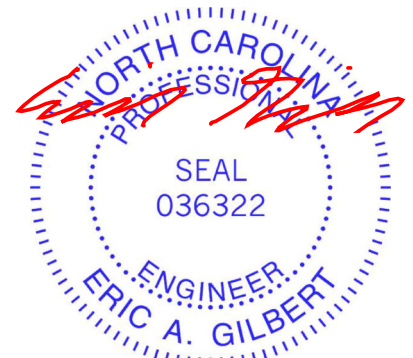

July 31, 2020

WARNING - Verify design parameters and READ NOTES ON THIS AND INCLUDED MITEK REFERENCE PAGE MII-7473 rev. 5/19/2020 BEFORE USE.

Design valid for use only with MiTek® connectors. This design is based only upon parameters shown, and is for an individual building component, not a truss system. Before use, the building designer must verify the applicability of design parameters and properly incorporate this design into the overall building design. Bracing indicated is to prevent buckling of individual truss web and/or chord members only. Additional temporary and permanent bracing is always required for stability and to prevent collapse with possible personal injury and property damage. For general guidance regarding the fabrication, storage, delivery, erection and bracing of trusses and truss systems, see **ANSI/TPI1 Quality Criteria, DSB-89 and BCSI Building Component Safety Information** available from Truss Plate Institute, 2670 Crain Highway, Suite 203 Waldorf, MD 20601



818 Soundside Road
 Edenton, NC 27932

Job	Truss	Truss Type	Qty	Ply	Weaver / 69 Thomas Farm / Harnett	E14688953
J1220-5726	P1	COMMON	5	1	Job Reference (optional)	

Comtech, Inc., Fayetteville, NC - 28314,

8.330 s May 6 2020 MiTek Industries, Inc. Fri Jul 31 14:42:03 2020 Page 1

ID:lwPOH6hK8Jeptt6SXqQOJcyzm6C-sGTQHT17hSfxuBA8nrsLFLvP0yRXcxri36WC7ysWPO



Scale = 1:21.4

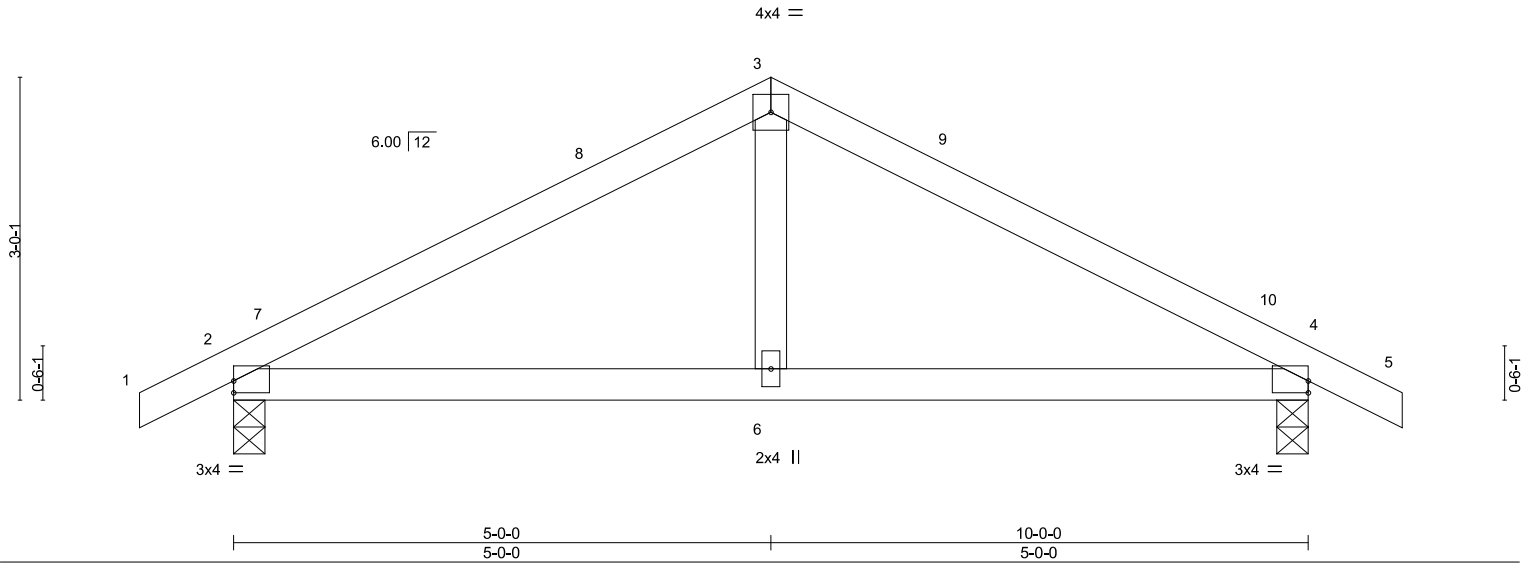

Plate Offsets (X,Y)-- [2:0-0-0,0-1-5], [4:0-0-0,0-1-5]

LOADING (psf)	SPACING-	CSL.	DEFL.	in (loc)	I/defl	L/d	PLATES	GRIP
TCLL 20.0	Plate Grip DOL 1.15	TC 0.24	Vert(LL) 0.04	2-6	>999	240	MT20	244/190
TCDL 10.0	Lumber DOL 1.15	BC 0.20	Vert(CT) -0.03	4-6	>999	240		
BCLL 0.0 *	Rep Stress Incr YES	WB 0.05	Horz(CT) 0.01	4	n/a	n/a		
BCDL 10.0	Code IRC2015/TPI2014	Matrix-S					Weight: 38 lb	FT = 20%

LUMBER-	BRACING-
TOP CHORD 2x4 SP No.1	TOP CHORD Structural wood sheathing directly applied or 6-0-0 oc purlins.
BOT CHORD 2x4 SP No.1	BOT CHORD Rigid ceiling directly applied or 9-8-3 oc bracing.
WEBS 2x4 SP No.2	

REACTIONS. (size) 2=0-3-8, 4=0-3-8
 Max Horz 2=38(LC 11)
 Max Uplift 2=-89(LC 9), 4=-89(LC 8)
 Max Grav 2=450(LC 1), 4=450(LC 1)

FORCES. (lb) - Max. Comp./Max. Ten. - All forces 250 (lb) or less except when shown.
 TOP CHORD 2-3=-518/572, 3-4=-518/572
 BOT CHORD 2-6=-392/392, 4-6=-392/392
 WEBS 3-6=-311/234

- NOTES-**
- Unbalanced roof live loads have been considered for this design.
 - Wind: ASCE 7-10; Vult=130mph (3-second gust) Vasd=103mph; TCCL=6.0psf; BCDL=6.0psf; h=15ft; Cat. II; Exp C; Enclosed; MWFRS (envelope) and C-C Exterior(2) -0-10-8 to 3-6-5, Interior(1) 3-6-5 to 5-0-0, Exterior(2) 5-0-0 to 9-4-13, Interior(1) 9-4-13 to 10-10-8 zone; porch left and right exposed; C-C for members and forces & MWFRS for reactions shown; Lumber DOL=1.60 plate grip DOL=1.60
 - This truss has been designed for a 10.0 psf bottom chord live load nonconcurrent with any other live loads.
 - * This truss has been designed for a live load of 30.0psf on the bottom chord in all areas where a rectangle 3-6-0 tall by 2-0-0 wide will fit between the bottom chord and any other members.
 - Provide mechanical connection (by others) of truss to bearing plate capable of withstanding 100 lb uplift at joint(s) 2, 4.

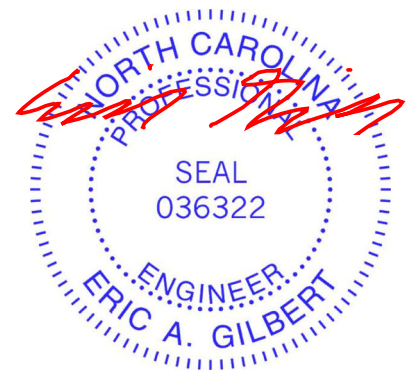

July 31, 2020

Job J1220-5726	Truss P1GE	Truss Type COMMON SUPPORTED GAB	Qty 1	Ply 1	Weaver / 69 Thomas Farm / Harnett	E14688954
-------------------	---------------	------------------------------------	----------	----------	-----------------------------------	-----------

Comtech, Inc., Fayetteville, NC - 28314,

8.330 s May 6 2020 MiTek Industries, Inc. Fri Jul 31 14:42:04 2020 Page 1

ID:IwPOH6hK8Jeptt6SXqQOJcym6C-KS1oVpumSmnoWLIKLYNaChu38QHZG33_xjs3kZysWPn



Scale = 1:21.4

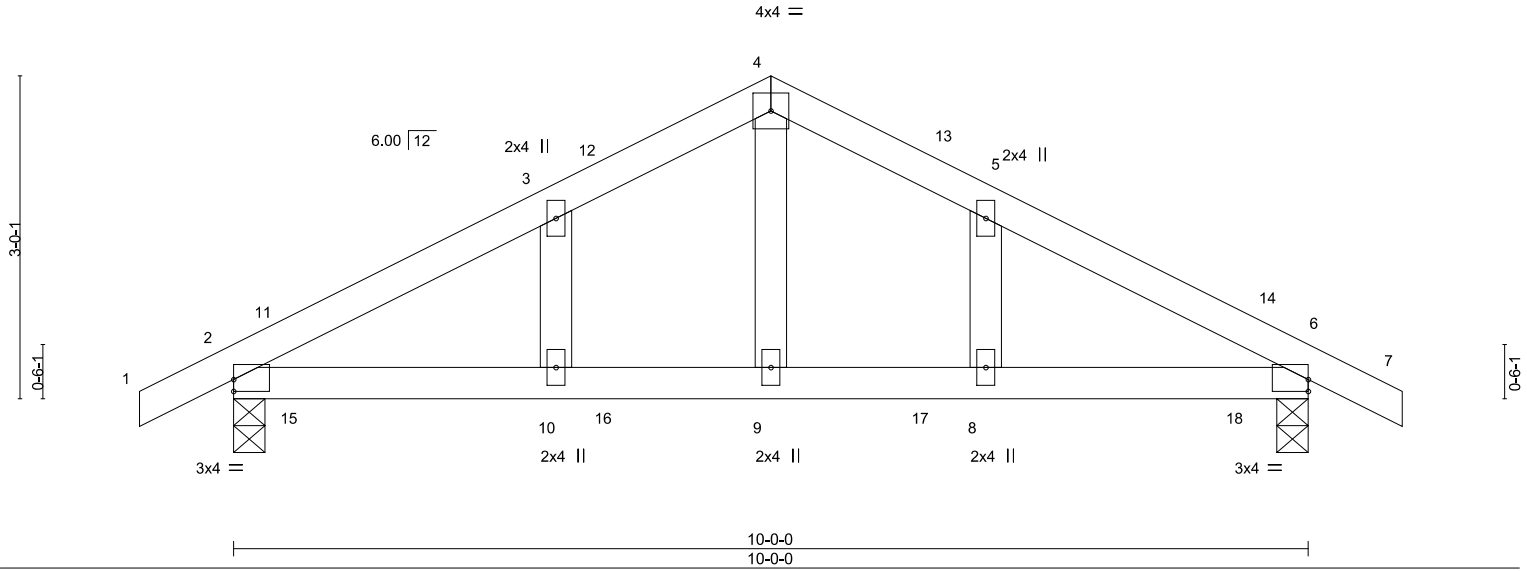

Plate Offsets (X,Y)-- [2:0-0-0,0-1-5], [6:0-0-0,0-1-5]

LOADING (psf)	SPACING-	CSI.	DEFL.	in (loc)	l/defl	L/d	PLATES	GRIP
TCLL 20.0	Plate Grip DOL 1.15	TC 0.24	Vert(LL) -0.02	10	>999	360	MT20	244/190
TCDL 10.0	Lumber DOL 1.15	BC 0.27	Vert(CT) -0.03	2-10	>999	240		
BCLL 0.0 *	Rep Stress Incr YES	WB 0.06	Horz(CT) -0.01	6	n/a	n/a		
BCDL 10.0	Code IRC2015/TPI2014	Matrix-S	Wind(LL) 0.05	2-10	>999	240		
							Weight: 43 lb	FT = 20%

LUMBER-	BRACING-
TOP CHORD 2x4 SP No.1	TOP CHORD Structural wood sheathing directly applied or 6-0-0 oc purlins.
BOT CHORD 2x4 SP No.1	BOT CHORD Rigid ceiling directly applied or 8-1-12 oc bracing.
OTHERS 2x4 SP No.2	

REACTIONS. (size) 2=0-3-8, 6=0-3-8
 Max Horz 2=59(LC 12)
 Max Uplift 2=-117(LC 9), 6=-117(LC 8)
 Max Grav 2=450(LC 1), 6=450(LC 1)

FORCES. (lb) - Max. Comp./Max. Ten. - All forces 250 (lb) or less except when shown.
 TOP CHORD 2-3=-514/746, 3-4=-448/794, 4-5=-448/794, 5-6=-514/746
 BOT CHORD 2-10=-515/397, 9-10=-515/397, 8-9=-515/397, 6-8=-515/397
 WEBS 4-9=-435/200

- NOTES-**
- Unbalanced roof live loads have been considered for this design.
 - Wind: ASCE 7-10; Vult=130mph (3-second gust) Vasd=103mph; TCCL=6.0psf; BCDL=6.0psf; h=15ft; Cat. II; Exp C; Enclosed; MWFRS (envelope) gable end zone and C-C Corner(3) -0-10-8 to 3-6-5, Exterior(2) 3-6-5 to 5-0-0, Corner(3) 5-0-0 to 9-4-13, Exterior(2) 9-4-13 to 10-10-8 zone; porch left and right exposed; C-C for members and forces & MWFRS for reactions shown; Lumber DOL=1.60 plate grip DOL=1.60
 - Truss designed for wind loads in the plane of the truss only. For studs exposed to wind (normal to the face), see Standard Industry Gable End Details as applicable, or consult qualified building designer as per ANSI/TPI 1.
 - Gable studs spaced at 2-0-0 oc.
 - This truss has been designed for a 10.0 psf bottom chord live load nonconcurrent with any other live loads.
 - * This truss has been designed for a live load of 30.0psf on the bottom chord in all areas where a rectangle 3-6-0 tall by 2-0-0 wide will fit between the bottom chord and any other members.
 - Provide mechanical connection (by others) of truss to bearing plate capable of withstanding 100 lb uplift at joint(s) except (jt=lb) 2=117, 6=117.



July 31, 2020

Symbols

PLATE LOCATION AND ORIENTATION

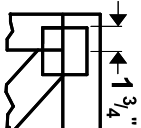

Center plate on joint unless x, y offsets are indicated. Dimensions are in ft-in-sixteenths. Apply plates to both sides of truss and fully embed teeth.

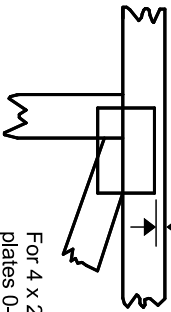

For 4 x 2 orientation, locate plates 0- 1/16" from outside edge of truss.



This symbol indicates the required direction of slots in connector plates.

* Plate location details available in **MiTek 20/20 software** or upon request.

PLATE SIZE

4 X 4

The first dimension is the plate width measured perpendicular to slots. Second dimension is the length parallel to slots.

LATERAL BRACING LOCATION



Indicated by symbol shown and/or by text in the bracing section of the output. Use T or I bracing if indicated.

BEARING

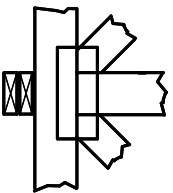

Indicates location where bearings (supports) occur. Icons vary but reaction section indicates joint number where bearings occur. Min size shown is for crushing only.

Industry Standards:

ANSI/TPI 1: National Design Specification for Metal Plate Connected Wood Truss Construction.
DSB-89: Design Standard for Bracing.
BCSI: Building Component Safety Information, Guide to Good Practice for Handling, Installing & Bracing of Metal Plate Connected Wood Trusses.

Numbering System

6-4-8 dimensions shown in ft-in-sixteenths (Drawings not to scale)

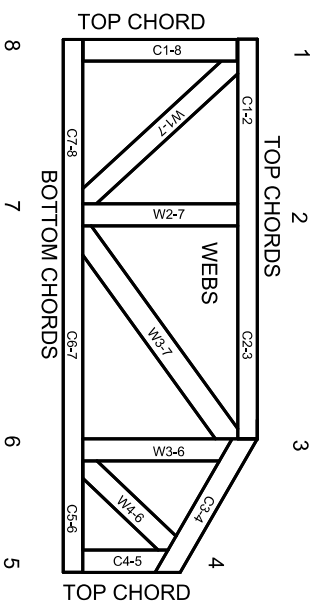

JOINTS ARE GENERALLY NUMBERED/LETTERED CLOCKWISE AROUND THE TRUSS STARTING AT THE JOINT FARTHEST TO THE LEFT.

CHORDS AND WEBS ARE IDENTIFIED BY END JOINT NUMBERS/LETTERS.

PRODUCT CODE APPROVALS

ICC-ES Reports:

ESR-1311, ESR-1352, ESR1988
ER-3907, ESR-2362, ESR-1397, ESR-3282

Trusses are designed for wind loads in the plane of the truss unless otherwise shown.

Lumber design values are in accordance with ANSI/TPI 1 section 6.3 These truss designs rely on lumber values established by others.

© 2012 MITteK® All Rights Reserved



MiTek Engineering Reference Sheet: MIL-7473 rev. 5/19/2020



General Safety Notes

Failure to Follow Could Cause Property Damage or Personal Injury

1. Additional stability bracing for truss system, e.g. diagonal or X-bracing, is always required. See BCSI.
2. Truss bracing must be designed by an engineer. For wide truss spacing, individual lateral braces themselves may require bracing, or alternative Tor I bracing should be considered.
3. Never exceed the design loading shown and never stack materials on inadequately braced trusses.
4. Provide copies of this truss design to the building designer, erection supervisor, property owner and all other interested parties.
5. Cut members to bear tightly against each other.
6. Place plates on each face of truss at each joint and embed fully. Knots and wane at joint locations are regulated by ANSI/TPI 1.
7. Design assumes trusses will be suitably protected from the environment in accord with ANSI/TPI 1.
8. Unless otherwise noted, moisture content of lumber shall not exceed 19% at time of fabrication.
9. Unless expressly noted, this design is not applicable for use with fire retardant, preservative treated, or green lumber.
10. Camber is a non-structural consideration and is the responsibility of truss fabricator. General practice is to camber for dead load deflection.
11. Plate type, size, orientation and location dimensions indicated are minimum plating requirements.
12. Lumber used shall be of the species and size, and in all respects, equal to or better than that specified.
13. Top chords must be sheathed or purlins provided at spacing indicated on design.
14. Bottom chords require lateral bracing at 10 ft. spacing, or less, if no ceiling is installed, unless otherwise noted.
15. Connections not shown are the responsibility of others.
16. Do not cut or alter truss member or plate without prior approval of an engineer.
17. Install and load vertically unless indicated otherwise.
18. Use of green or treated lumber may pose unacceptable environmental, health or performance risks. Consult with project engineer before use.
19. Review all portions of this design (front, back, words and pictures) before use. Reviewing pictures alone is not sufficient.
20. Design assumes manufacture in accordance with ANSI/TPI 1 Quality Criteria.
21. The design does not take into account any dynamic or other loads other than those expressly stated.