

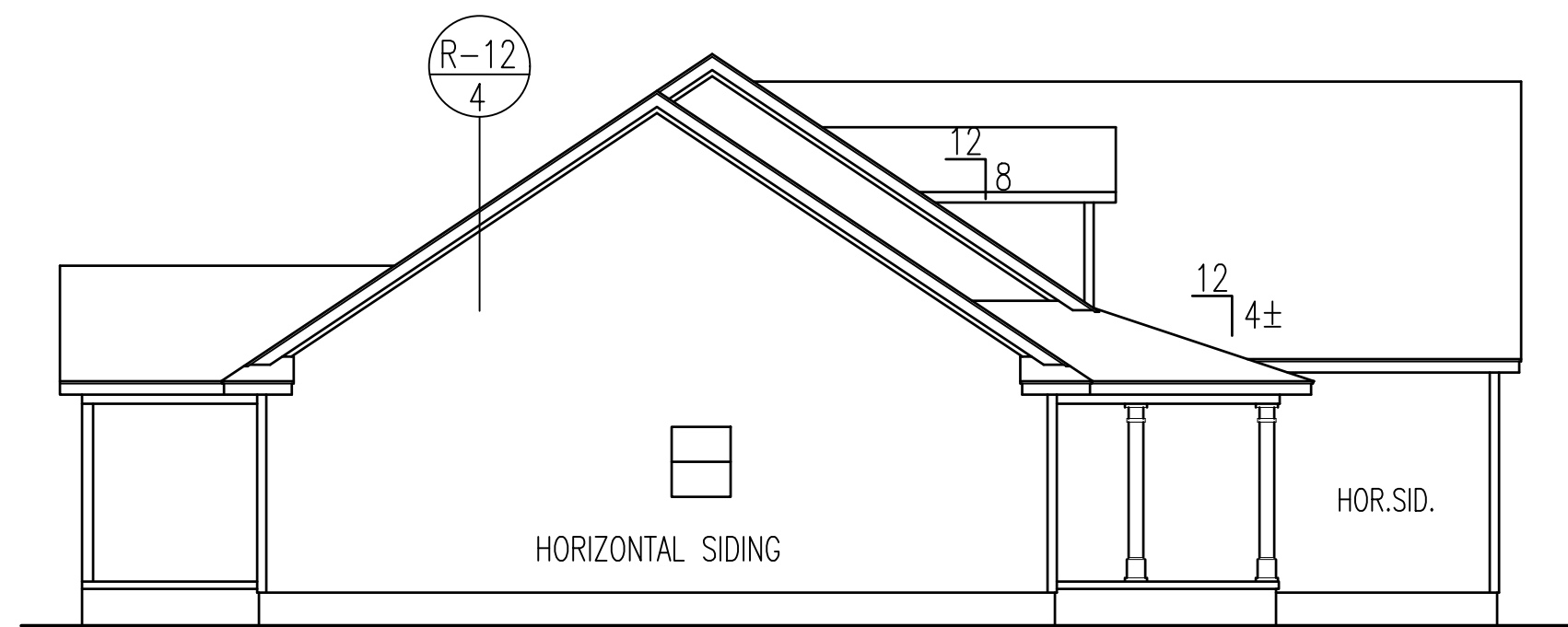

FRONT ELEVATION
SCALE: 1/4" = 1'-0"

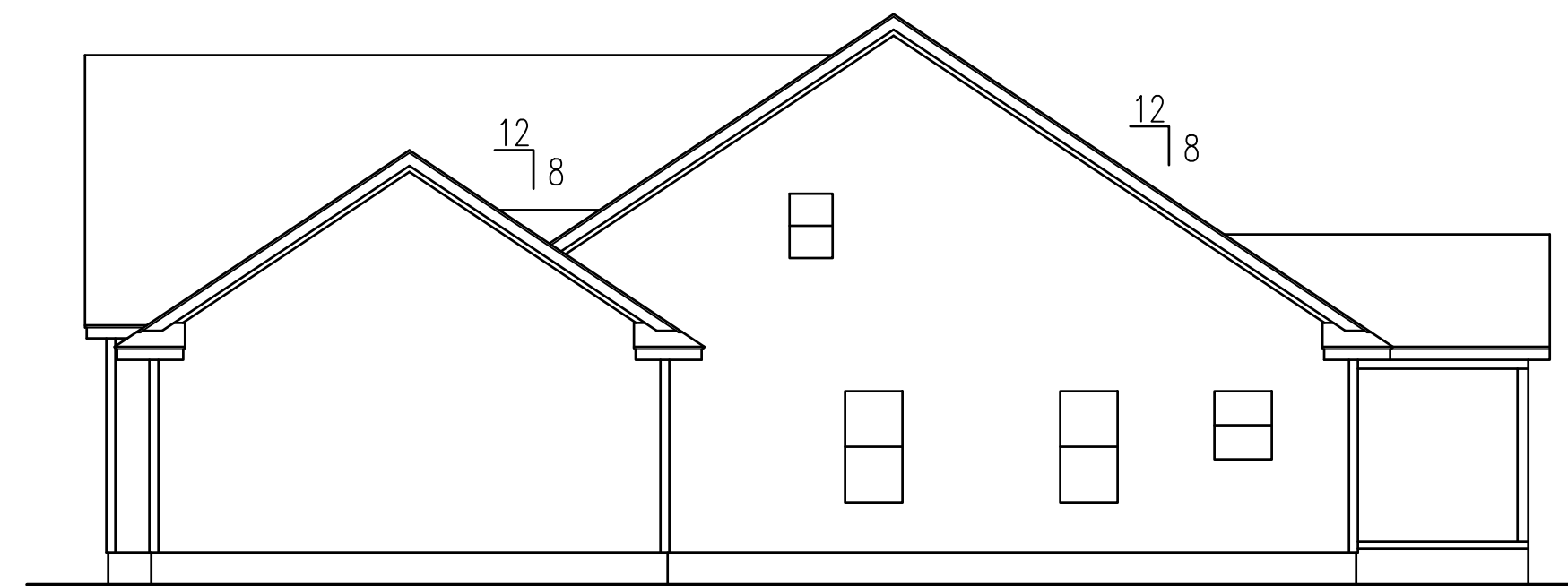

LEFT ELEVATION



RIGHT ELEVATION

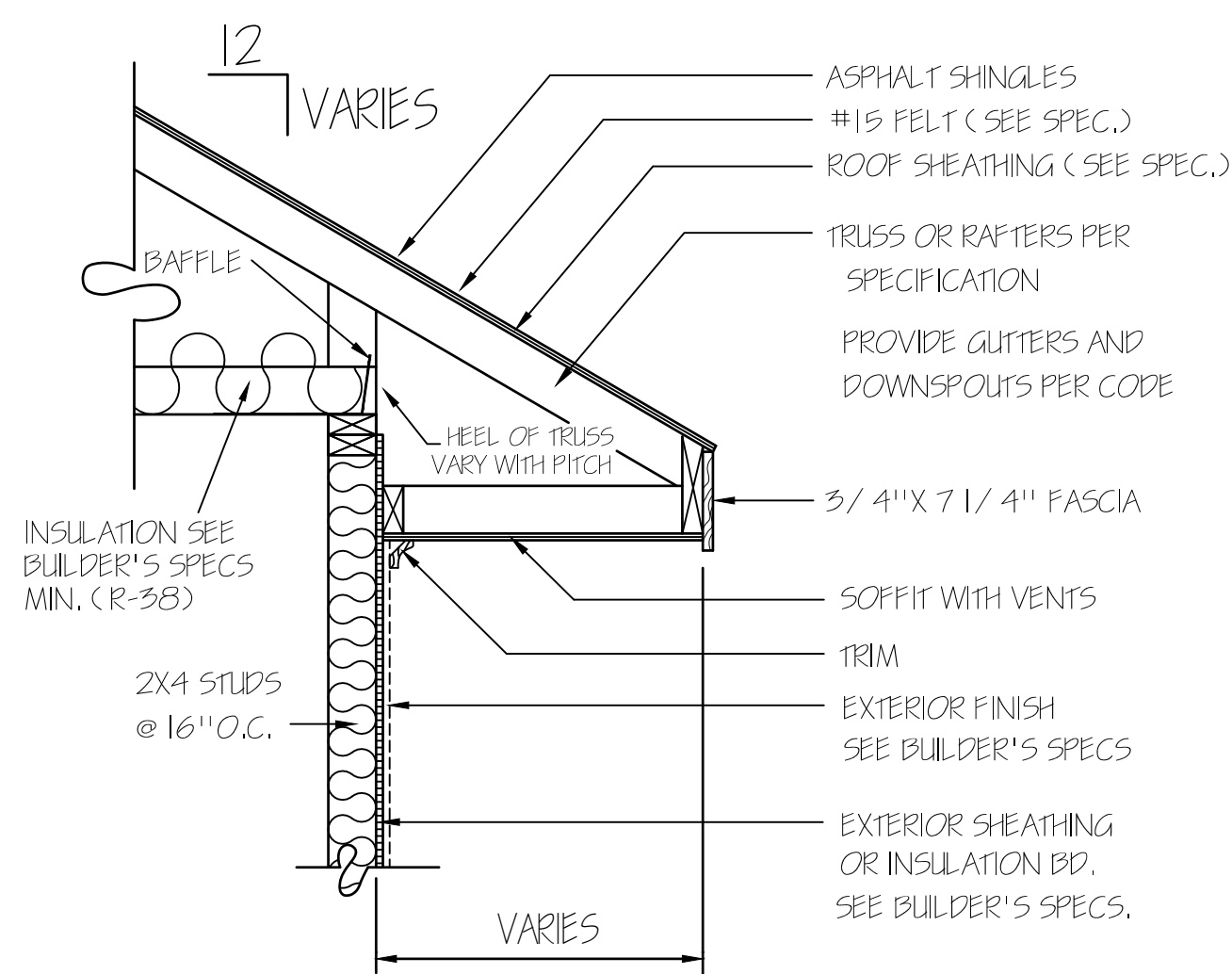

HERO PACKAGE

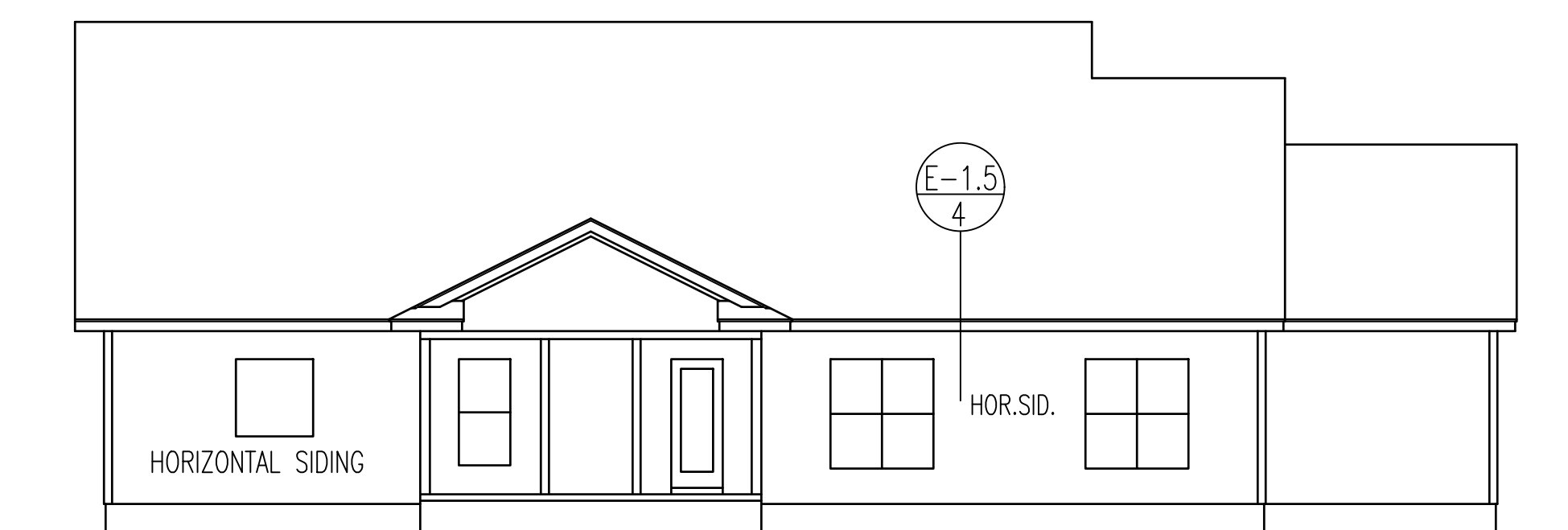

REAR ELEVATION
SCALE: 1/8" = 1'-0"

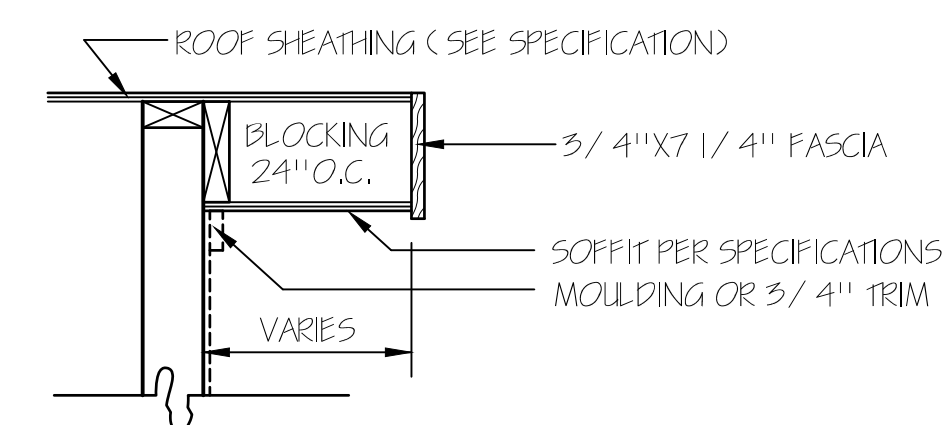

RAKE DETAIL FOR GABLE ENDS

TM DESIGNS
 RESIDENTIAL PLANS BY TINA MCFADDEN
 (910) 354-4736 TMDDESIGNS2016@GMAIL.COM

WATERMARK HOMES
 EXCLUSIVE RESIDENCE DESIGN FOR:

NAME: SHASTA FIR III
 LOT: 19 OAK HAVEN

© 2016. COPYRIGHT ALL RIGHTS RESERVED
 TM DESIGNS WILL NOT BE LIABLE FOR ANY ERRORS NOT BROUGHT TO THEIR ATTENTION PRIOR TO THE START OF CONSTRUCTION. WHILE EVERY EFFORT WAS MADE IN THE PREPARATION OF THESE DRAWINGS AND DIMENSIONS TO AVOID ERRORS THE OWNER AND/OR BUILDER SHALL VERIFY ALL DIMENSIONS, DETAILS, LOCAL AND STATE CODES.
 I HEREBY CERTIFY THAT THIS DRAWING MEETS LOCAL CODES, 2012 INTERNATIONAL BUILDING CODES.
 THIS IS FOR THE CONSTRUCTION OF ONE HOUSE ON A SINGLE LOT, NOT TO BE REUSED.

PLAN NUMBER
 RG25-A06
OPTION #1

1	GARAGE	F R
DATE:	5/26/17	

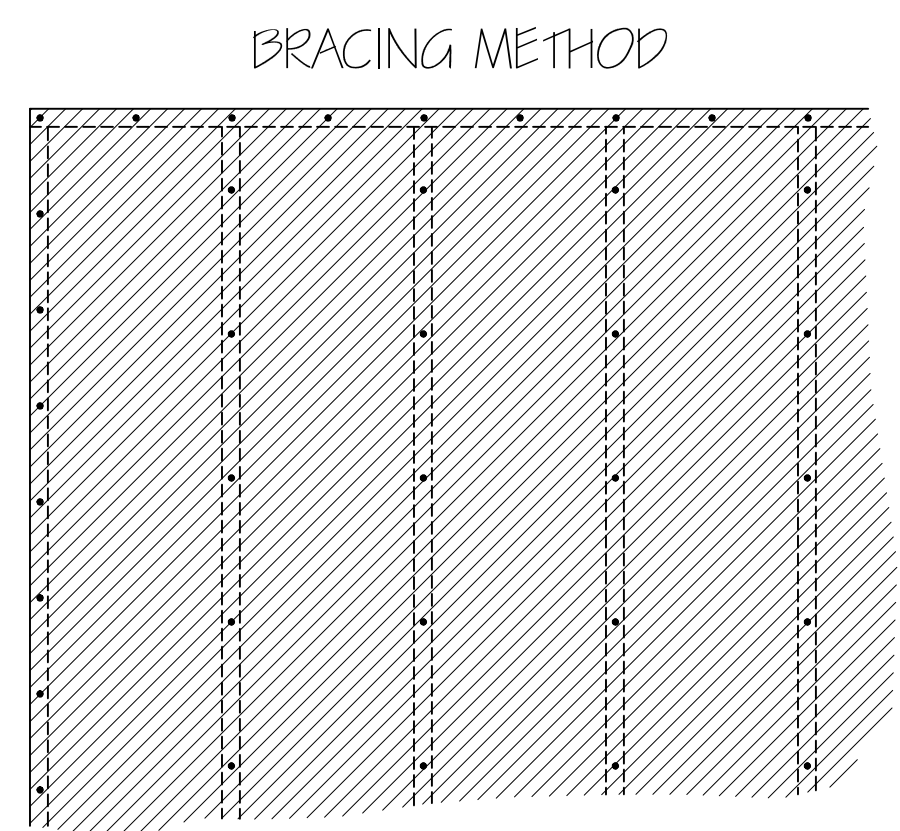
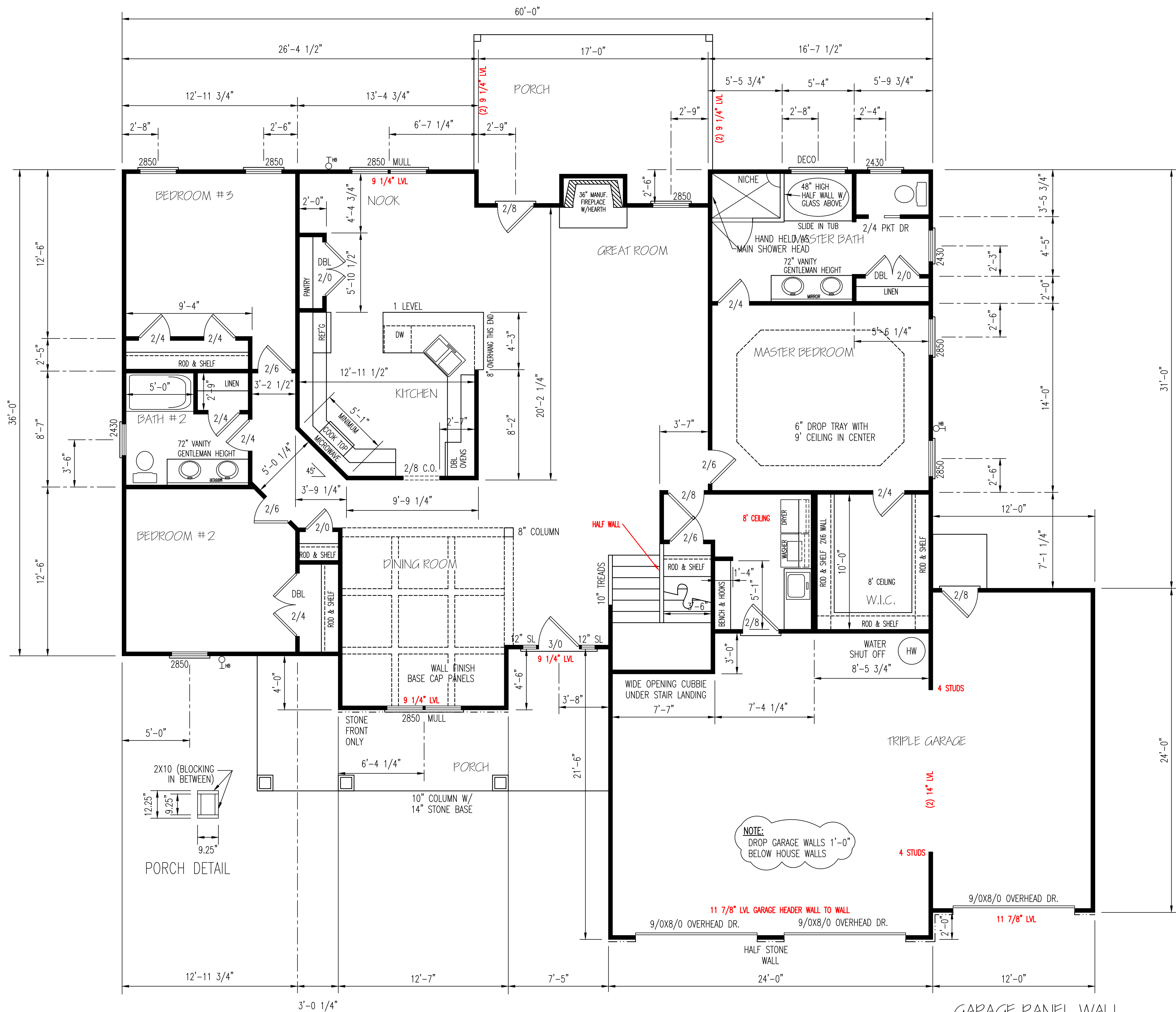

EXTERIOR WALLS (2) 2X10 HEADERS		
CLEAR SPAN FOR HEADER	NUMBER OF STUDS	
	JACKS	KINGS
ALL DOOR & C.O. BELOW 4'	1	1
ALL DOOR & C.O. 4' TO 7'-11"	2	2
ALL DOOR & C.O. 8' AND ABOVE	SIZED BY ENGINEER	

EXTERIOR WALL TO BE FULLY SHEATHED WITH 7/16" OSB. NAILING PATTERN TO BE 5" ON ALL EDGES AND 12" IN FIELD, WITH 6d NAILS.

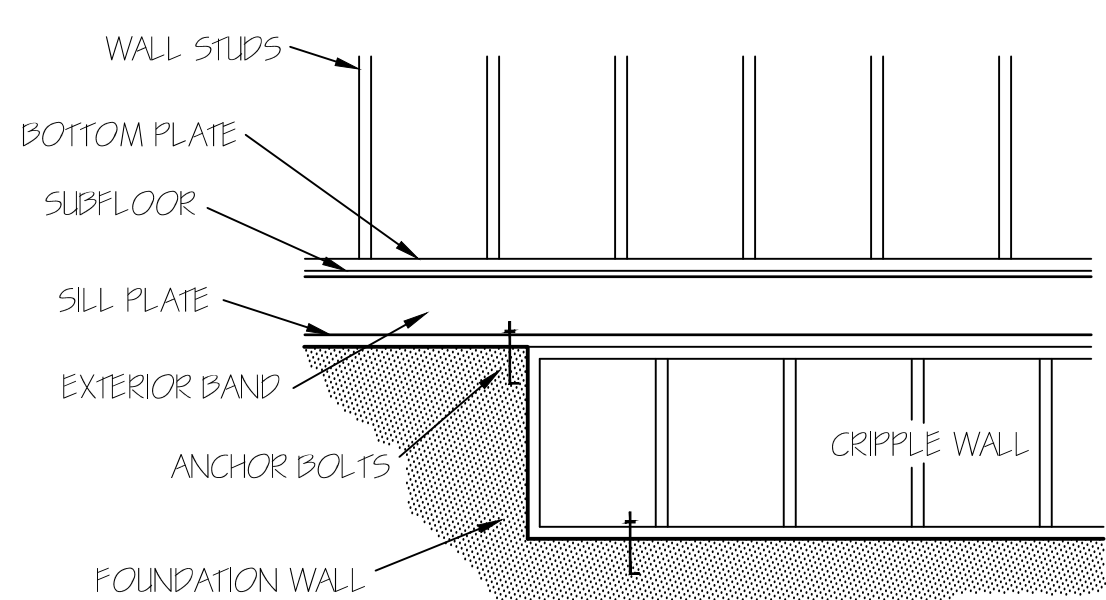

FOUNDATION CRIPPLE WALLS SHALL BE FRAMED OF STUDS NOT SMALLER THAN THE STUDDING ABOVE. WHEN EXCEEDING 4 FT. IN HEIGHT, SUCH WALLS SHALL BE FRAMED OF STUDS HAVING THE SIZE REQUIRED FOR AN ADDITIONAL STORY. CRIPPLE WALLS WITH A STUD HEIGHT LESS THAN 14 INCHES SHALL BE CONTINUOUSLY SHEATHED ON ONE SIDE WITH WOOD STRUCTURAL PANELS FASTENED TO BOTH THE TOP AND BOTTOM PLATES IN ACCORDANCE WITH TABLE R602.3(1), OR CRIPPLE WALLS SHALL BE CONSTRUCTED OF SOLID BLOCKING.

NOTE:
CEILING ARE 9'-0"
UNLESS NOTED.
SET WINDOWS @ 7'-4"
UNLESS NOTED.

HERO PACKAGE

FIRST FLOOR PLAN
SCALE: 1/4"=1'-0"

HEATED AREA	
1ST FL.	2148 SQ FT
2ND FL.	412 SQ FT
TOTAL	2560 SQ FT

OTHER AREAS	
GARAGE	808 SQ FT
F.PORCH	213 SQ FT
R.PORCH	219 SQ FT
STORAGE	279 SQ FT

ENERGY TABLE
UFACTOR OF WINDOWS 3.0
CLIMATE ZONE 3
INSULATION: WALLS 15
CEILING 38
FLOORS 19

NOTE:
DROP GARAGE WALLS 1'-0"
BELOW HOUSE WALLS

GARAGE PANEL WALL

GARAGE PANEL WALLS UNDER 24" WIDE SHOULD BE EITHER PORTAL FRAMED OR 7/16" OSB ON BOTH SIDES WITH A NAILING PATTERN OF 3" ON ALL PANEL EDGES AND 6" IN THE FIELD.

EXCLUSIVE RESIDENCE DESIGN FOR:
WATERMARK HOMES

TM DESIGNS
RESIDENTIAL PLANS BY TINA MCFADDEN
(910) 354-4736 TMDDESIGNS2016@GMAIL.COM

NAME: SHASTA FIR III

LOT: 19 OAK HAVEN

© 2016. COPYRIGHT ALL RIGHTS RESERVED
TM DESIGNS WILL NOT BE LIABLE FOR ANY ERRORS NOT BROUGHT TO THEIR ATTENTION PRIOR TO THE START OF CONSTRUCTION. WHILE EVERY EFFORT WAS MADE IN THE PREPARATION OF THESE DRAWINGS AND DIMENSIONS TO AVOID ERRORS THE OWNER AND/OR BUILDER SHALL VERIFY ALL DIMENSIONS, DETAILS, LOCAL AND STATE CODES.

THIS IS FOR THE CONSTRUCTION OF ONE HOUSE ON A SINGLE LOT, NOT TO BE REUSED

THEREBY CERTIFY THAT THIS DRAWING MEETS LOCAL CODES, 2012 INTERNATIONAL BUILDING CODES		
PLAN NUMBER RG25-A06		
OPTION #1		
2	GARAGE	F R
A	DATE:	7/1/20

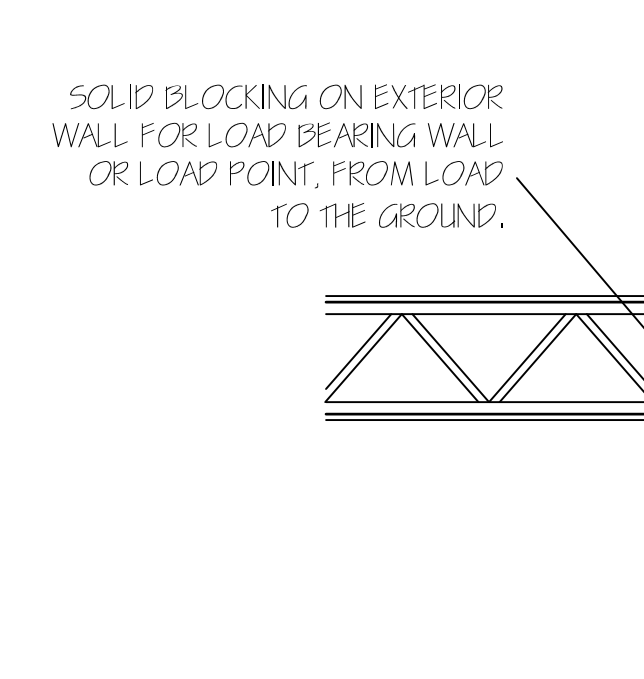
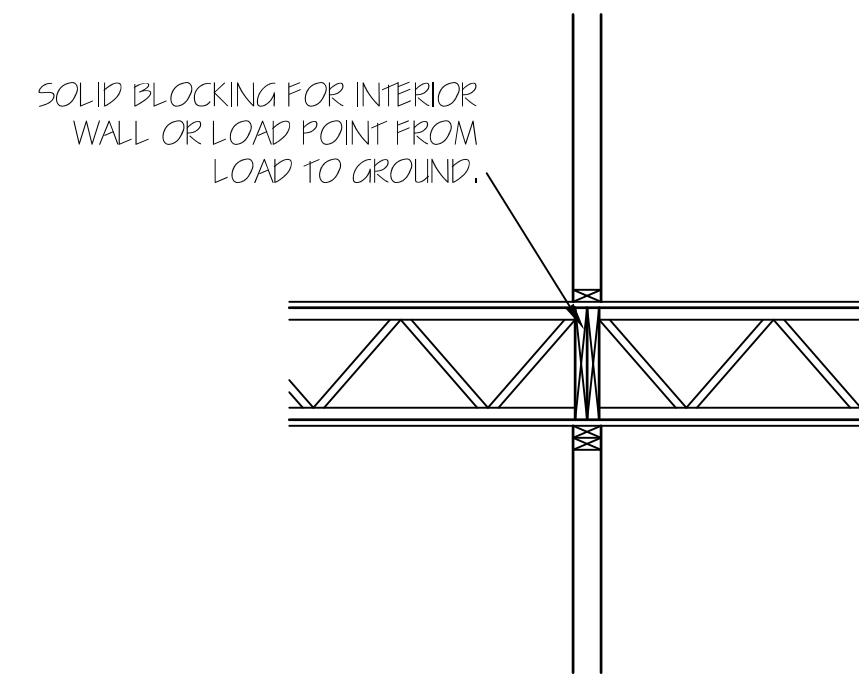
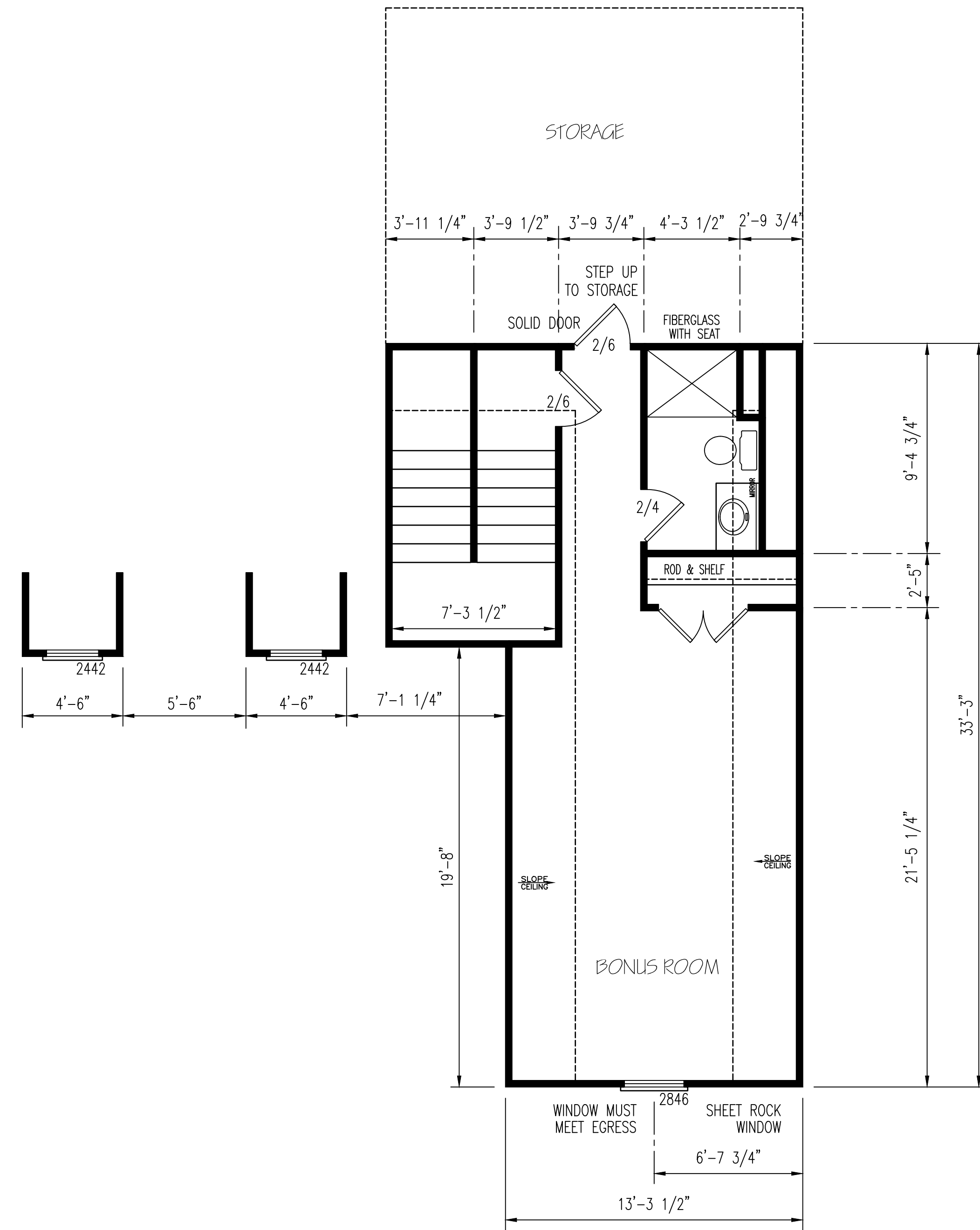

EXTERIOR WALLS (2) 2X10 HEADERS		
NUMBER OF STUDS	CLEAR SPAN FOR HEADER	
KINGS	JACKS	
1	1	ALL DOOR & C.O. BELOW 4'
2	2	ALL DOOR & C.O. 4' TO 7'-11"
SIZED BY ENGINEER		ALL DOOR & C.O. 8' AND ABOVE
UNLESS NOTED OTHERWISE		

SECOND FLOOR PLAN
SCALE: 1/4"=1'-0"

© 2016. COPYRIGHT ALL RIGHTS RESERVED

TM DESIGNS WILL NOT BE LIABLE FOR ANY ERRORS NOT BROUGHT TO THEIR ATTENTION PRIOR TO THE START OF CONSTRUCTION. WHILE EVERY EFFORT WAS MADE IN THE PREPARATION OF THESE DRAWINGS AND DIMENSIONS TO AVOID ERRORS THE OWNER AND/OR BUILDER SHALL VERIFY ALL DIMENSIONS, DETAILS, LOCAL AND STATE CODES.

I HEREBY CERTIFY THAT THIS DRAWING MEETS LOCAL CODES, 2012 INTERNATIONAL BUILDING CODES

THIS IS FOR THE CONSTRUCTION OF ONE HOUSE ON A SINGLE LOT, NOT TO BE REUSED

PLAN NUMBER
RG25-A06

OPTION #1

2 B	GARAGE	F	R
	DATE:	7/1/20	

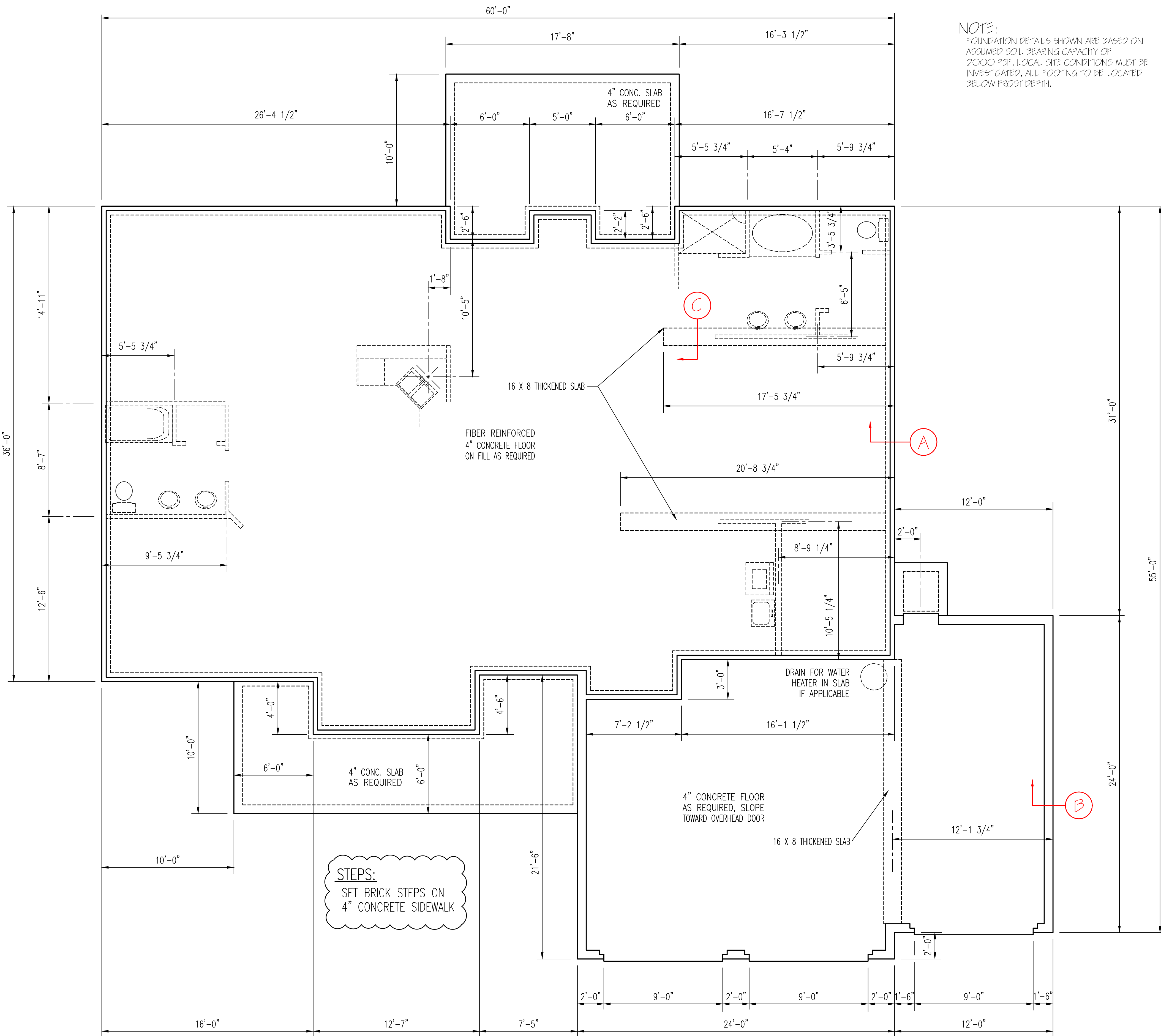

NOTE:
FOUNDATION DETAILS SHOWN ARE BASED ON ASSUMED SOIL BEARING CAPACITY OF 2000 PSF. LOCAL SITE CONDITIONS MUST BE INVESTIGATED, ALL FOOTING TO BE LOCATED BELOW FROST DEPTH.

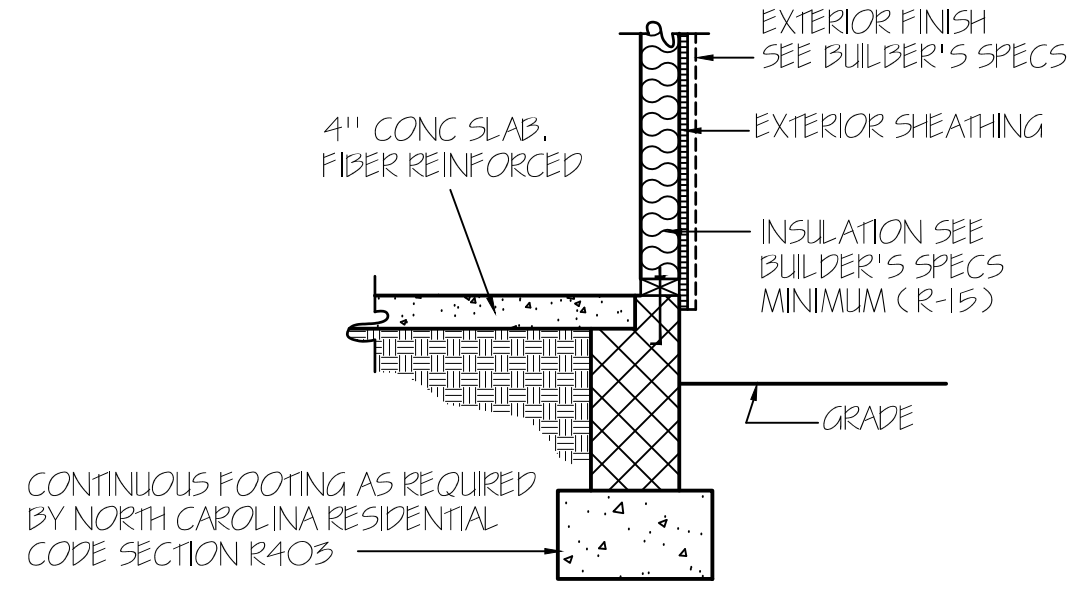

NOTE:
PERIMETER INSUL. MAY EXTEND HORIZ. UNDER SLAB 24" OR VERTICAL 24" BELOW SLAB FLOOR

CONCRETE SLAB FLOOR — (A)

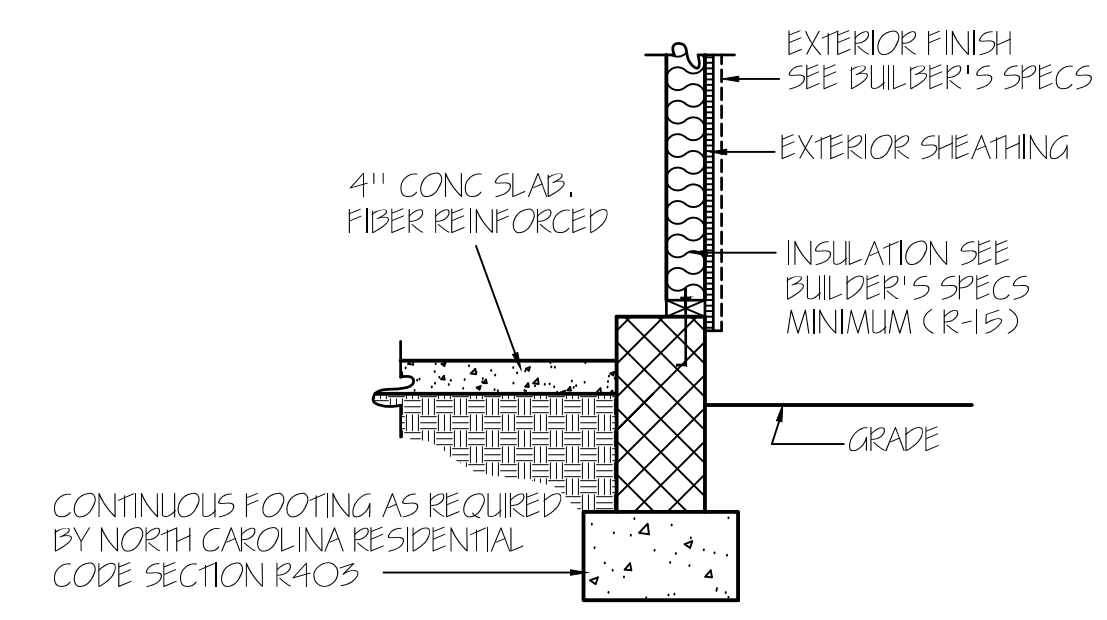

NOTE:
PERIMETER INSUL. MAY EXTEND HORIZ. UNDER SLAB 24" OR VERTICAL 24" BELOW SLAB FLOOR

GARAGE WALL — (B)

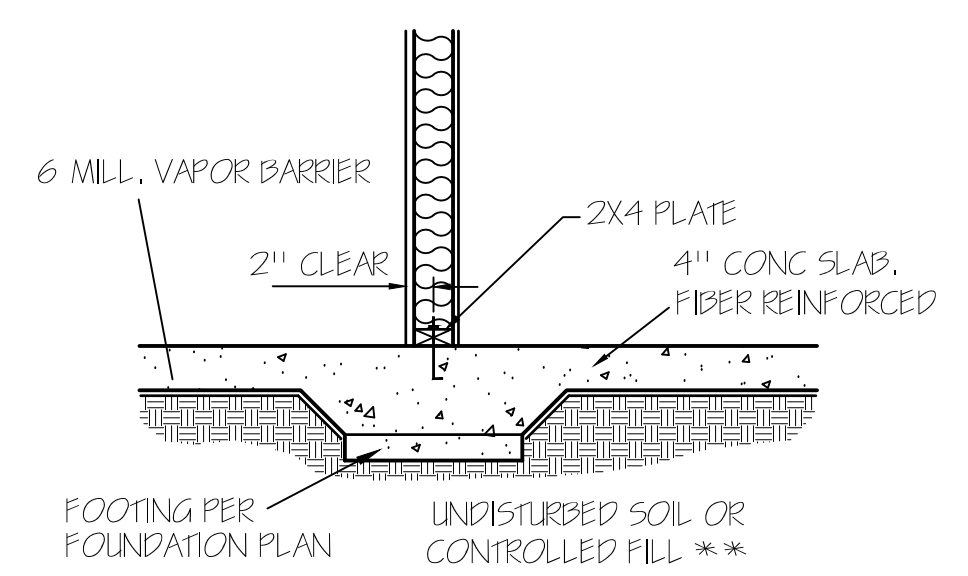

LOAD BEARING WALL THICKENED SLAB — (C)

ALL FOUNDATION WALLS HAVE A 16" X 8" FOOTING UNLESS NOTED OTHERWISE.

FOUNDATION PLAN
SCALE: 1/4" = 1'-0"

WALL ANCHOR OPTIONS
USE ANCHOR BOLTS
ANCHOR BOLTS: 1/2" DIA. BOLTS AT 6'-0" O.C.
AND NOT MORE THAN 12" FROM CORNERS, EMBEDDED MIN. 7" INTO FOUNDATION. USE A MIN. OF 2 BOLTS PER EACH STUD WALL

TM DESIGNS
 RESIDENTIAL PLANS BY TINA MCFADDEN
 (910) 354-4736 TMDDESIGNS2016@GMAIL.COM

WATERMARK HOMES
 EXCLUSIVE RESIDENCE DESIGN FOR:

LOT: 19 OAK HAVEN
 NAME: SHASTA FIR III

© 2016. COPYRIGHT ALL RIGHTS RESERVED
 TM DESIGNS WILL NOT BE LIABLE FOR ANY ERRORS NOT BROUGHT TO THEIR ATTENTION PRIOR TO THE START OF CONSTRUCTION. WHILE EVERY EFFORT WAS MADE IN THE PREPARATION OF THESE DRAWINGS AND DIMENSIONS TO AVOID ERRORS THE OWNER AND/OR BUILDER SHALL VERIFY ALL DIMENSIONS, DETAILS, LOCAL AND STATE CODES.
 THEREBY CERTIFY THAT THIS DRAWING MEETS LOCAL CODES, 2012 INTERNATIONAL BUILDING CODES
 THIS IS FOR THE CONSTRUCTION OF ONE HOUSE ON A SINGLE LOT, NOT TO BE REUSED

PLAN NUMBER	
RG25-A06	
OPTION #1	
3	GARAGE F R DATE: 7/1/20

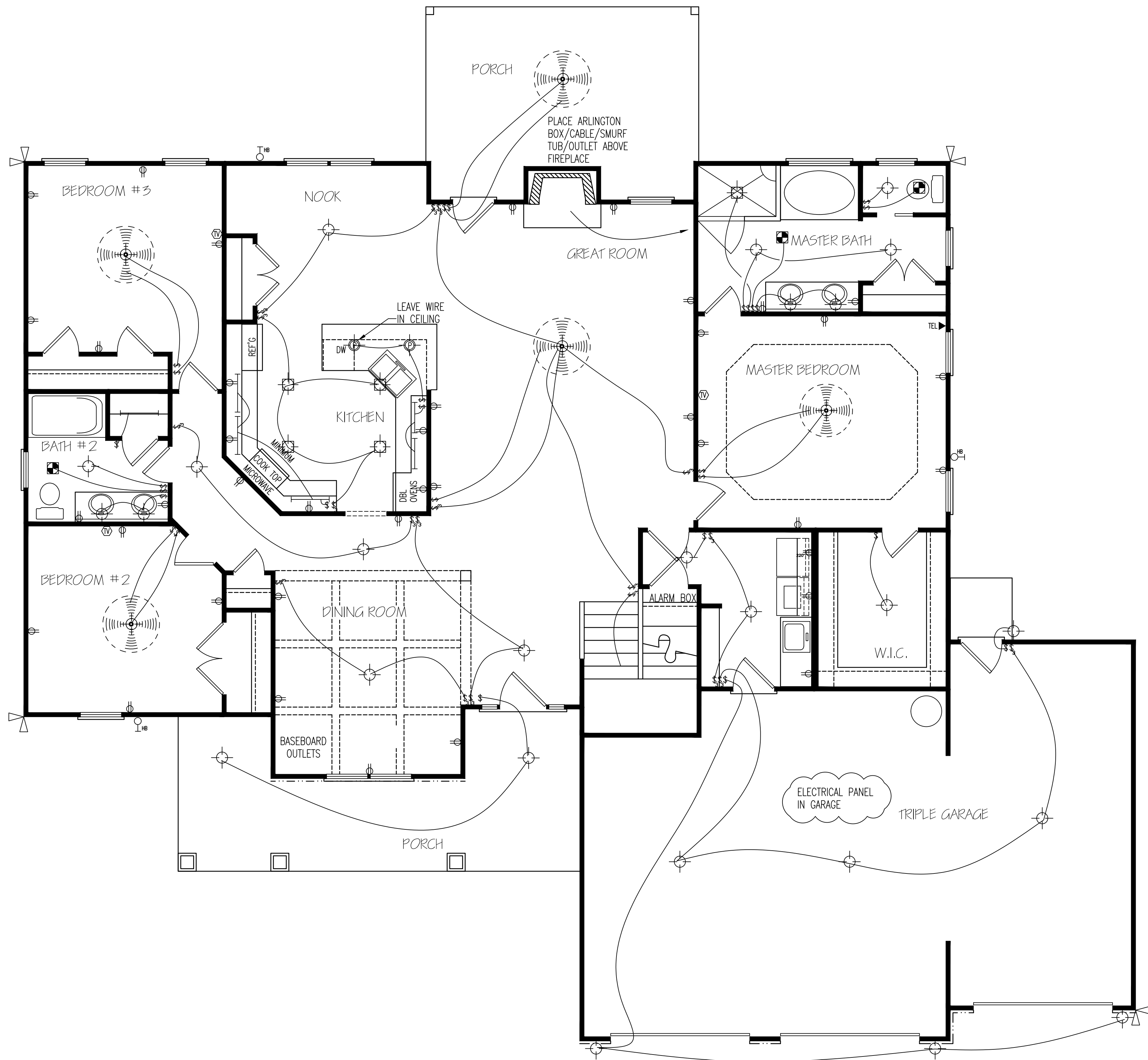

FIRST FLOOR
ELECTRICAL LAYOUT

NOTE: SWITCHED RECEPTACLES ARE HOT TOP AND SWITCHED BOTTOM

HERO PACKAGE

EXCLUSIVE RESIDENCE DESIGN FOR:
WATERMARK HOMES

NAME: SHASTA FIR III

LOT: 19 OAK HAVEN

© 2016. COPYRIGHT ALL RIGHTS RESERVED

TM DESIGNS WILL NOT BE LIABLE FOR ANY ERRORS NOT BROUGHT TO THEIR ATTENTION PRIOR TO THE START OF CONSTRUCTION. WHILE EVERY EFFORT WAS MADE IN THE PREPARATION OF THESE DRAWINGS AND DIMENSIONS TO AVOID ERRORS THE OWNER AND/OR BUILDER SHALL VERIFY ALL DIMENSIONS, DETAILS, LOCAL AND STATE CODES.

I HEREBY CERTIFY THAT THIS DRAWING MEETS LOCAL CODES, 2012 INTERNATIONAL BUILDING CODES

THIS IS FOR THE CONSTRUCTION OF ONE HOUSE ON A SINGLE LOT, NOT TO BE REUSED

PLAN NUMBER
RG25-A06

OPTION #1

E-1	GARAGE	F	R
	DATE:	7/1/20	

TM DESIGNS

RESIDENTIAL PLANS BY TINA MCFADDEN
(910) 354-4736 TMDESIGNS2016@GMAIL.COM

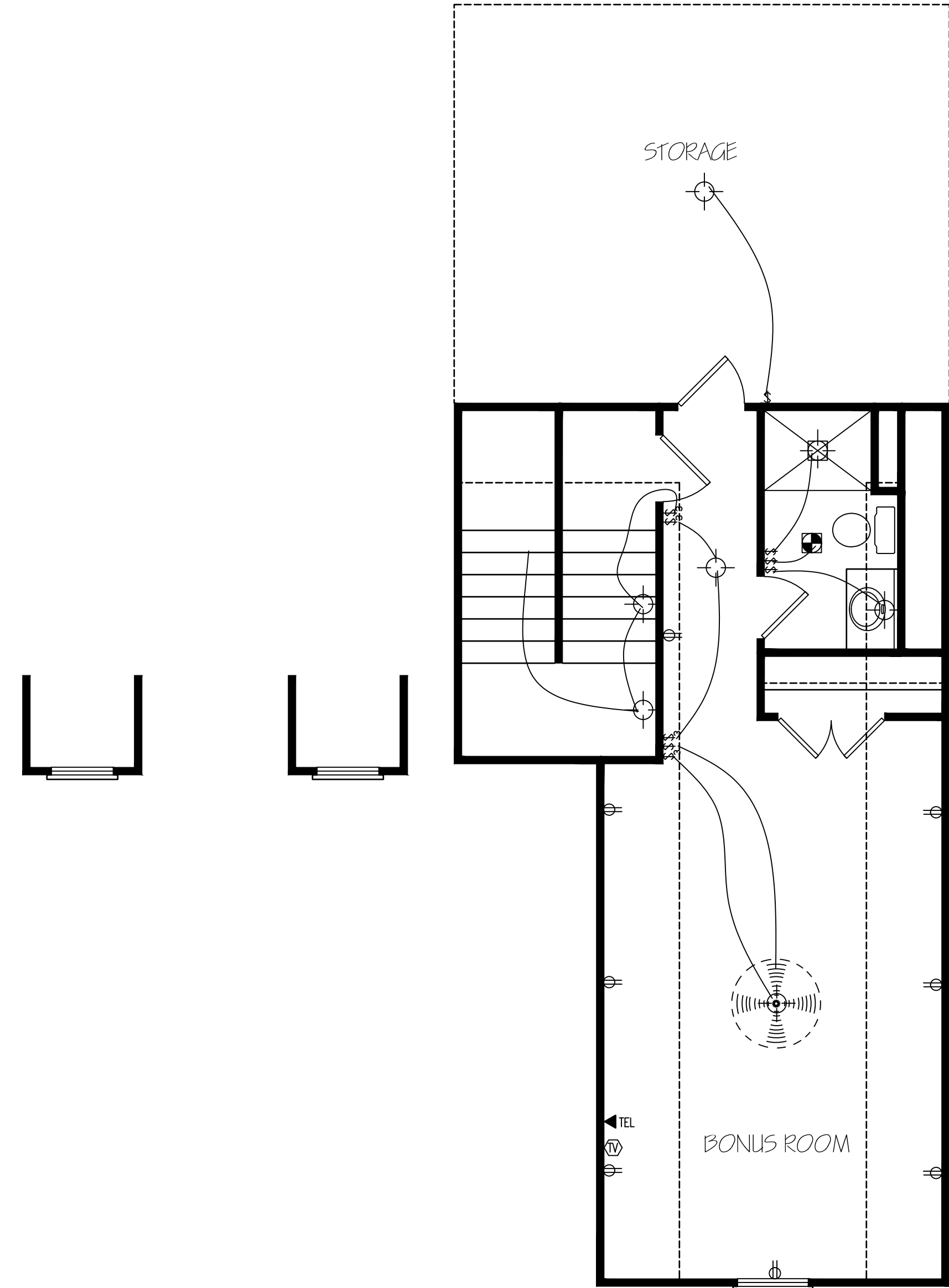

SECOND FLOOR
ELECTRICAL LAYOUT

NOTE: SWITCHED RECEPTACLES ARE HOT
TOP AND SWITCHED BOTTOM

EXCLUSIVE RESIDENCE DESIGN FOR:
WATERMARK HOMES
NAME: SHASTA FIR III

T M DESIGNS
RESIDENTIAL PLANS BY TINA MCFADDEN
(910) 354-4736 TMDESIGNS2016@GMAIL.COM

© 2016. COPYRIGHT ALL RIGHTS RESERVED

T M DESIGNS WILL NOT BE LIABLE FOR ANY ERRORS NOT BROUGHT TO THEIR ATTENTION PRIOR TO THE START OF CONSTRUCTION. WHILE EVERY EFFORT WAS MADE IN THE PREPARATION OF THESE DRAWINGS AND DIMENSIONS TO AVOID ERRORS THE OWNER AND / OR BUILDER SHALL VERIFY ALL DIMENSIONS, DETAILS, LOCAL AND STATE CODES.

I HEREBY CERTIFY THAT THIS DRAWING MEETS LOCAL CODES, 2012 INTERNATIONAL BUILDING CODES

THIS IS FOR THE CONSTRUCTION OF ONE HOUSE ON A SINGLE LOT, NOT TO BE REUSED

PLAN NUMBER
RG25-A06

OPTION #1

E-2	GARAGE	F	R
	DATE:	7/1/20	