

PlotID	Length	Product	Plies	Net Qty	Fab Type
J28	28' 0"	11 7/8" PJI-40	1	9	MFD
J24	24' 0"	11 7/8" PJI-40	1	10	MFD
J16	16' 0"	11 7/8" PJI-40	1	4	MFD
J14	14' 0"	11 7/8" PJI-40	1	17	MFD
J10	10' 0"	11 7/8" PJI-40	1	2	MFD
J4	4' 0"	11 7/8" PJI-40	1	1	MFD
DB3-2	28' 0"	2.0 RigidLam DF LVL 1-3/4 x 9-1/4	2	2	FF
DB1-2	22' 0"	2.0 RigidLam DF LVL 1-3/4 x 9-1/4	2	2	FF
DB4-2	20' 0"	2.0 RigidLam DF LVL 1-3/4 x 9-1/4	2	2	FF
DB2-2	16' 0"	2.0 RigidLam DF LVL 1-3/4 x 9-1/4	2	2	FF
RIM	12' 0"	1 1/8" x 11 7/8" APA Rim Board	1	20	FF
BP	2' 0"	11 7/8" PJI-40	1	14	FF

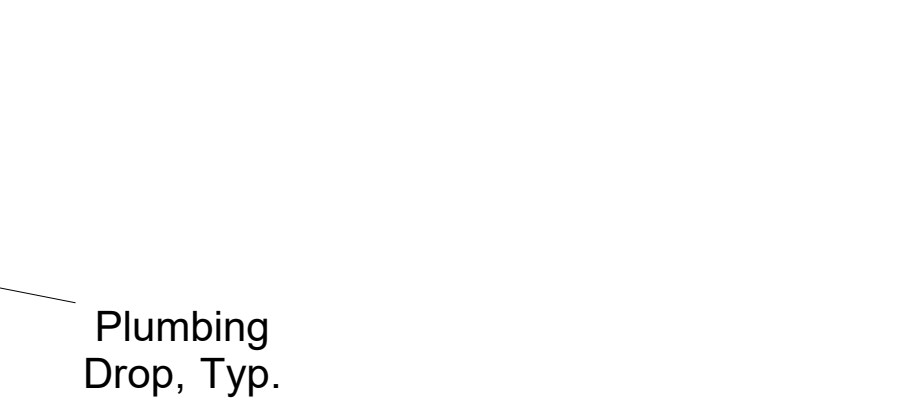
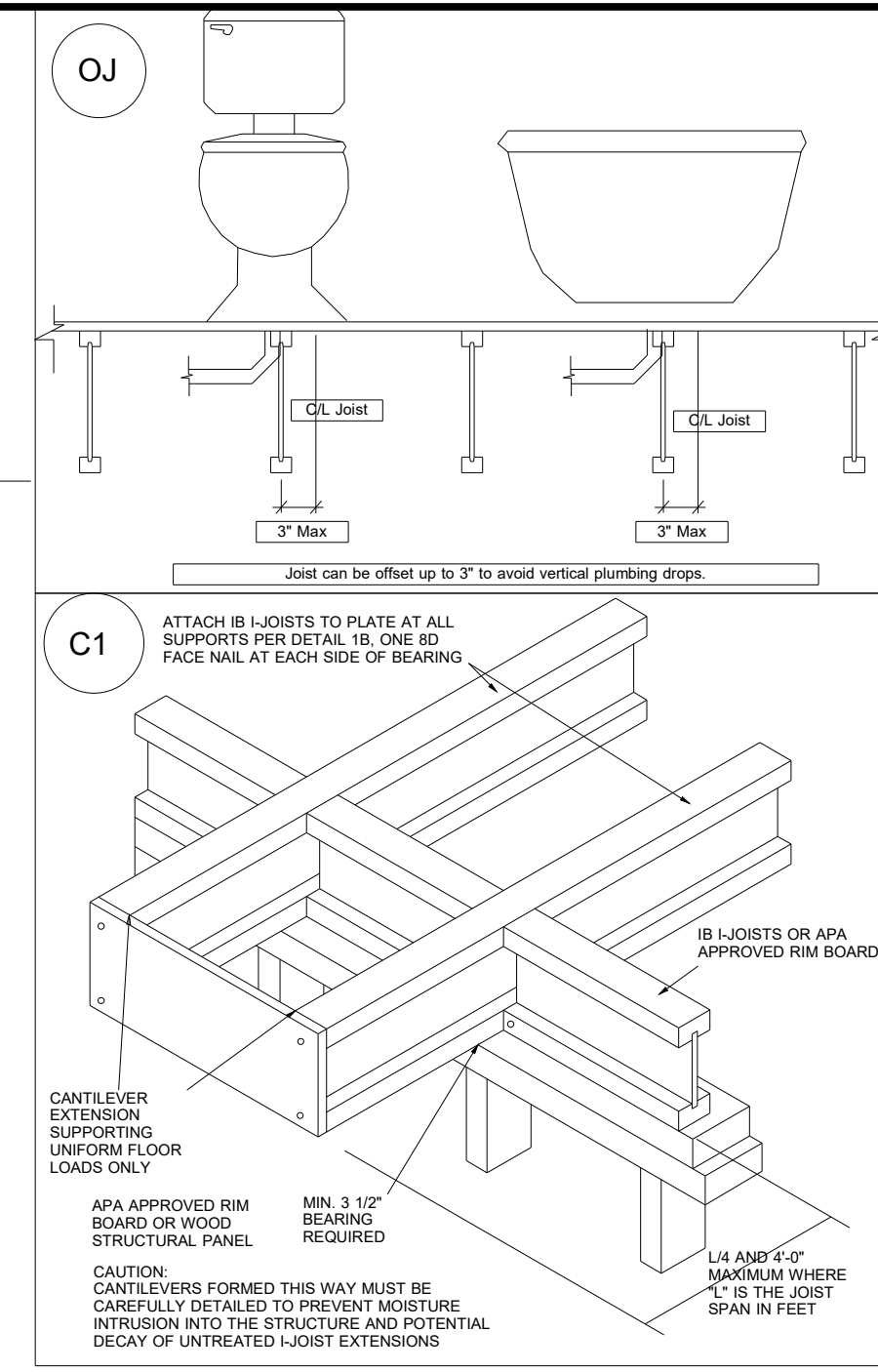

BLOCK SOLID UNDER ALL POST /POINT LOADS FROM ABOVE - TYPICAL AT ALL LOCATIONS

1st Floor I-Joist

DRAWING SCALE : NTS

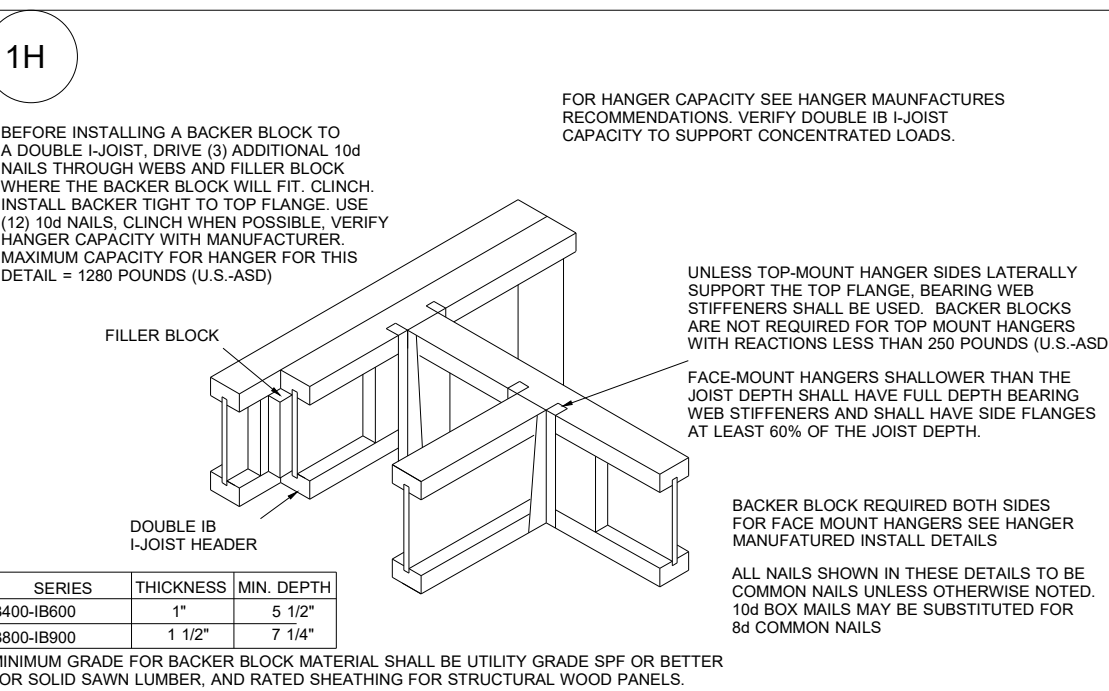
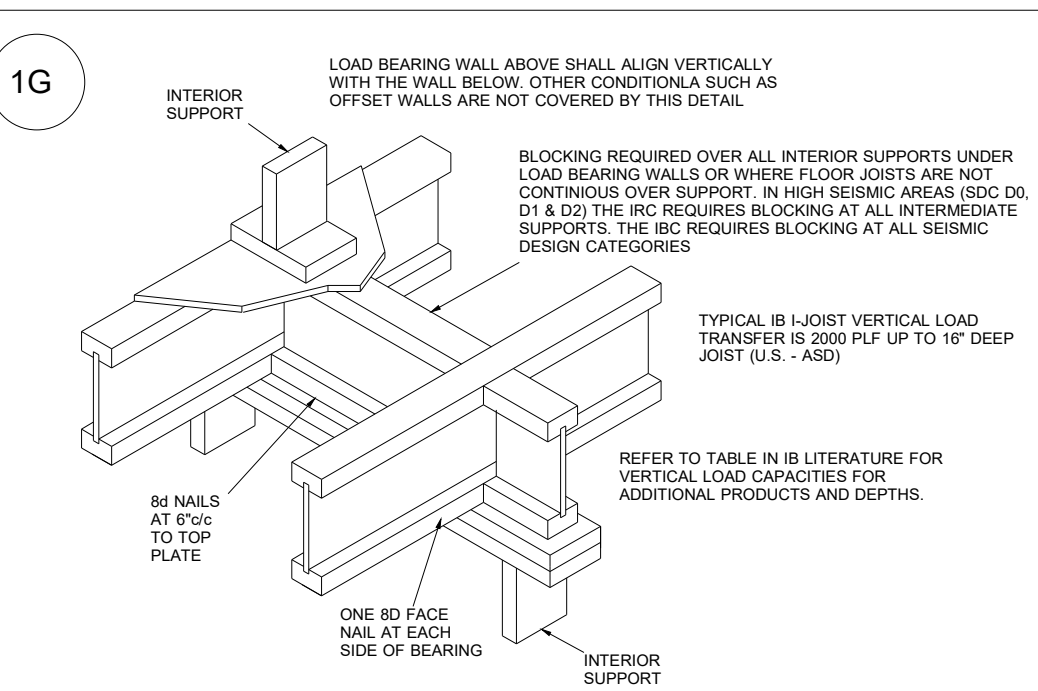
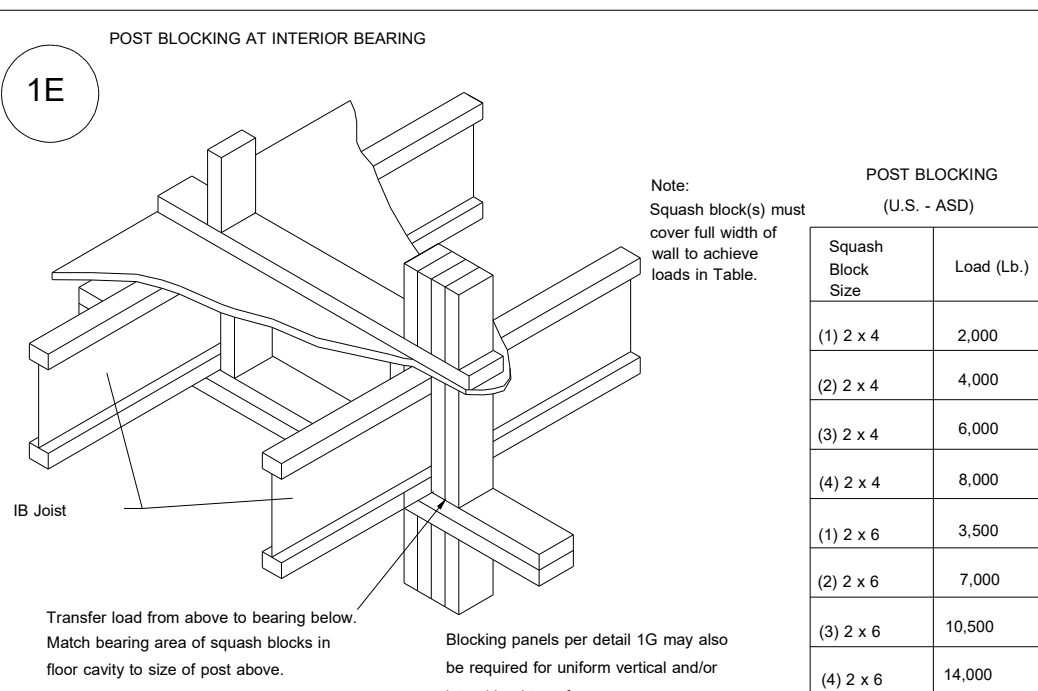
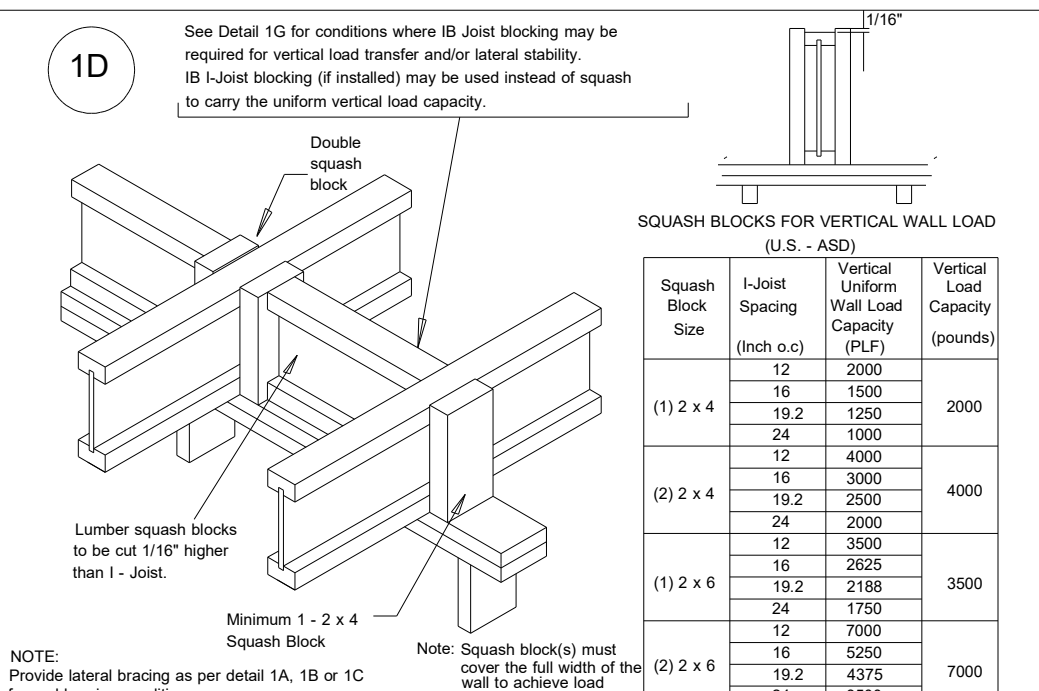
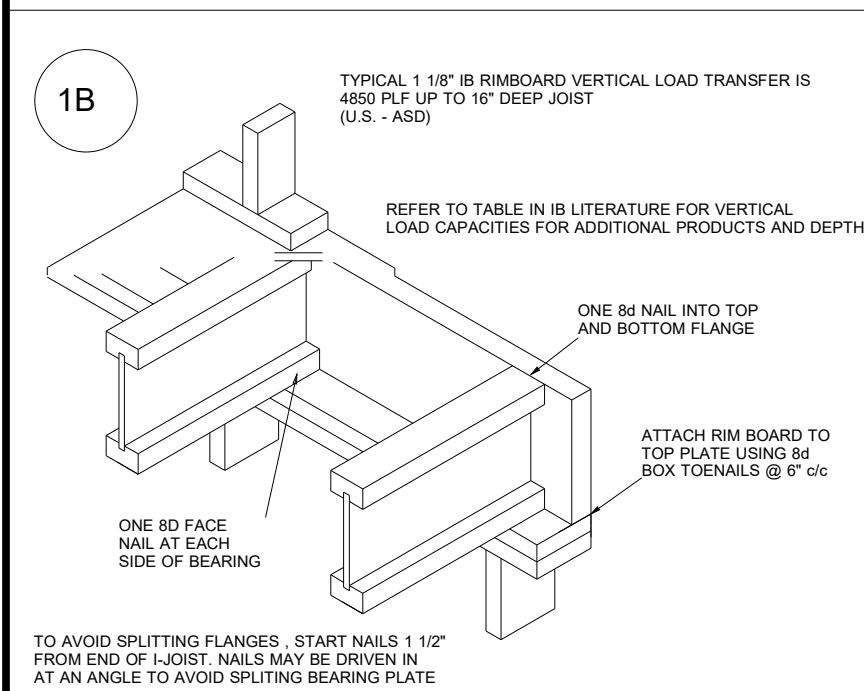

BBO = Beam by Others
PBO = Post by Others
GBO = Girder by Others
J = I-Joist
FB = Flush Beam
DB = Dropped Beam
BP = Blocking Panels
SB = Squash Blocks

REVISIONS	
DATE	BY
10.15.20	RKW

PROJECT NUMBER
20100066
 SHEET NUMBER
1 / 1



Freedom Family Homes
 BB-1398 Plan
1st FLOOR I-JOIST PLACEMENT PLAN