

Job 20-6466-A	Truss V04	Truss Type Valley	Qty 1	Ply 1	GARY ROBINSON-LOT 73 SOUTH CREEK WOODLAKE MODEL ROOF
------------------	--------------	----------------------	----------	----------	--

Riverside Roof Truss, LLC, Danville, VA. 24541

Run: 8.330 s Feb 24 2020 Print: 8.330 s Feb 24 2020 MiTek Industries, Inc. Wed Nov 11 16:38:58 2020 Page 1
ID:riFrQwqzJQyesEOjBg_H7VyKEle-?DDBDTFqCiuDqmmqY_205hltalbXuue5L?O010yKCyB

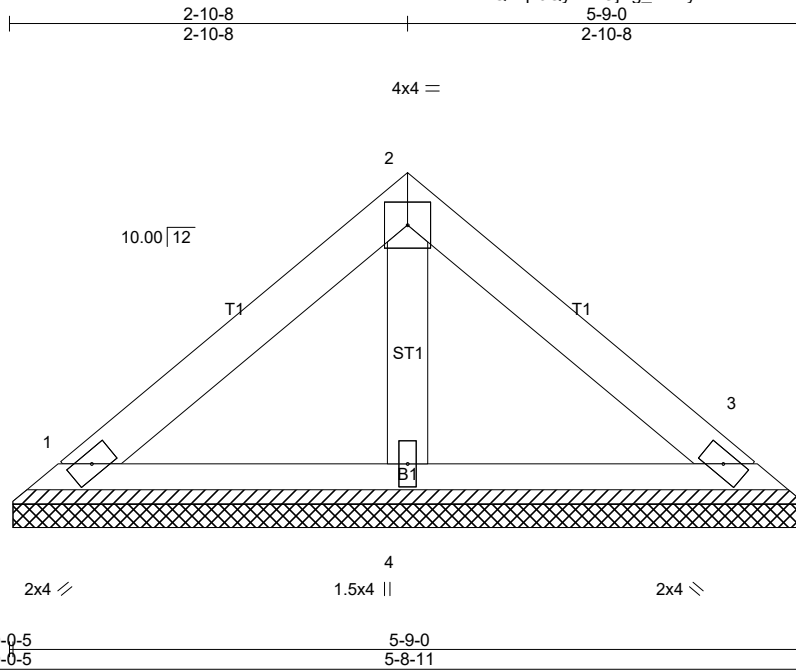

Scale = 1:16.6

LOADING (psf)	SPACING-	CSI.	DEFL.	PLATES	GRIP
TCLL (roof) 30.0	2-0-0	TC 0.15	in (loc) l/defl L/d	MT20	244/190
Snow (Pf/Pg) 23.1/30.0	Plate Grip DOL 1.15	BC 0.06	Vert(LL) n/a - n/a 999		
TCDL 10.0	Lumber DOL 1.15	WB 0.03	Vert(CT) n/a - n/a 999		
BCLL 0.0 *	Rep Stress Incr YES	Matrix-P	Horz(CT) 0.00 3 n/a n/a		
BCDL 10.0	Code IRC2015/TPI2014			Weight: 21 lb	FT = 20%

LUMBER-
TOP CHORD 2x4 SP No.2
BOT CHORD 2x4 SP No.2
OTHERS 2x4 SP No.3

BRACING-
TOP CHORD
BOT CHORD

Structural wood sheathing directly applied or 5-9-0 oc purlins.
Rigid ceiling directly applied or 10-0-0 oc bracing.

MiTek recommends that Stabilizers and required cross bracing be installed during truss erection, in accordance with Stabilizer Installation guide.

REACTIONS. (lb/size) 1=123/5-8-6 (min. 0-1-8), 3=123/5-8-6 (min. 0-1-8), 4=180/5-8-6 (min. 0-1-8)
Max Horz 1=-51(LC 12)
Max Uplift 1=-24(LC 17), 3=-30(LC 17)
Max Grav 1=145(LC 2), 3=145(LC 2), 4=204(LC 2)

FORCES. (lb) - Max. Comp./Max. Ten. - All forces 250 (lb) or less except when shown.

NOTES-

- Unbalanced roof live loads have been considered for this design.
- Wind: ASCE 7-10; Vult=130mph (3-second gust) Vasd=103mph; TCCL=6.0psf; BCDL=6.0psf; h=25ft; Cat. II; Exp B; Enclosed; MWFRS (envelope) gable end zone and C-C Exterior(2) zone; cantilever left and right exposed ; end vertical left and right exposed;C-C for members and forces & MWFRS for reactions shown; Lumber DOL=1.60 plate grip DOL=1.60
- TCLL: ASCE 7-10; Pr=30.0 psf (roof live load: Lumber DOL=1.15 Plate DOL=1.15); Pg=30.0 psf (ground snow); Pf=23.1 psf (flat roof snow: Lumber DOL=1.15 Plate DOL=1.15); Category II; Exp B; Partially Exp.; Ct=1.10
- Unbalanced snow loads have been considered for this design.
- Gable requires continuous bottom chord bearing.
- This truss has been designed for a 10.0 psf bottom chord live load nonconcurrent with any other live loads.
- * This truss has been designed for a live load of 20.0psf on the bottom chord in all areas where a rectangle 3-6-0 tall by 2-0-0 wide will fit between the bottom chord and any other members.
- Provide mechanical connection (by others) of truss to bearing plate capable of withstanding 100 lb uplift at joint(s) 1, 3.
- This truss is designed in accordance with the 2015 International Residential Code sections R502.11.1 and R802.10.2 and referenced standard ANSI/TPI 1.

LOAD CASE(S) Standard

Job 20-6466-A	Truss V03	Truss Type Valley	Qty 1	Ply 1	GARY ROBINSON-LOT 73 SOUTH CREEK WOODLAKE MODEL ROOF
------------------	--------------	----------------------	----------	----------	--

Riverside Roof Truss, LLC, Danville, VA. 24541

Run: 8.330 s Feb 24 2020 Print: 8.330 s Feb 24 2020 MiTek Industries, Inc. Wed Nov 11 16:38:58 2020 Page 1
ID:riFrQwqzJQyesEOjBg_H7VyKEle-?DDBDTFqCiuDqmmqY_205hIqwYLutn5L?0010yKCyB

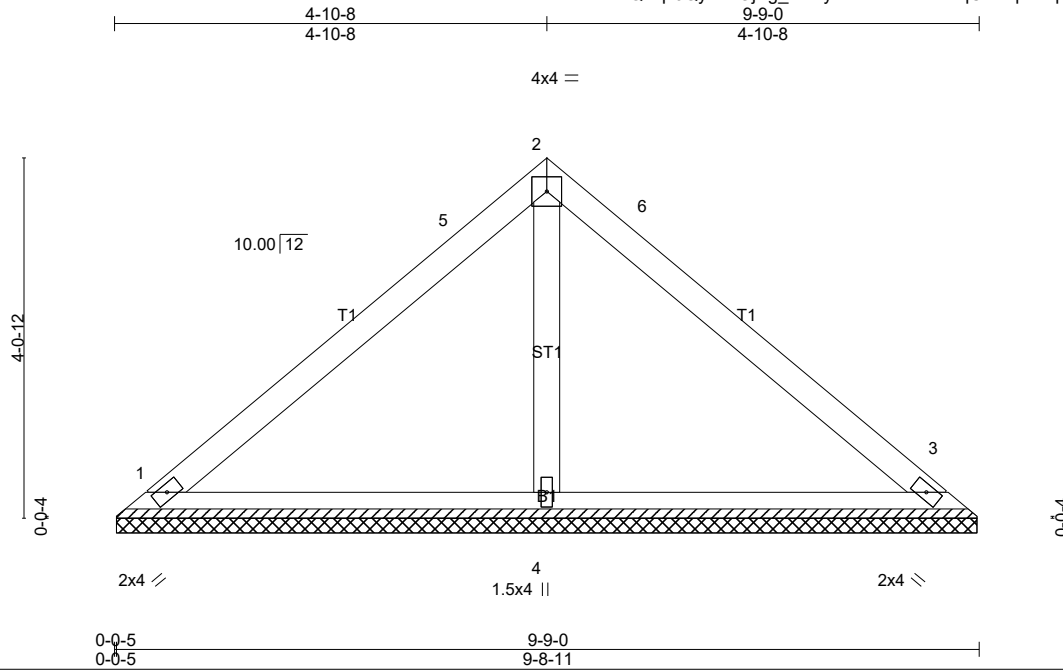

Scale = 1:26.0

LOADING (psf)	SPACING-	CSI.	DEFL.	PLATES	GRIP
TCLL (roof) 30.0	2-0-0	TC 0.38	in (loc) l/defl L/d	MT20	244/190
Snow (Pf/Pg) 23.1/30.0	Plate Grip DOL 1.15	BC 0.20	Vert(LL) n/a - n/a 999		
TCDL 10.0	Lumber DOL 1.15	WB 0.08	Vert(CT) n/a - n/a 999		
BCLL 0.0 *	Rep Stress Incr YES	Matrix-S	Horz(CT) 0.00 3 n/a n/a		
BCDL 10.0	Code IRC2015/TPI2014			Weight: 37 lb	FT = 20%

LUMBER-
TOP CHORD 2x4 SP No.2
BOT CHORD 2x4 SP No.2
OTHERS 2x4 SP No.3

BRACING-
TOP CHORD
BOT CHORD

Structural wood sheathing directly applied or 6-0-0 oc purlins.
Rigid ceiling directly applied or 10-0-0 oc bracing.

MiTek recommends that Stabilizers and required cross bracing be installed during truss erection, in accordance with Stabilizer Installation guide.

REACTIONS. (lb/size) 1=205/9-8-6 (min. 0-1-8), 3=205/9-8-6 (min. 0-1-8), 4=360/9-8-6 (min. 0-1-8)
Max Horz 1=92(LC 13)
Max Uplift 1=-31(LC 17), 3=-42(LC 17), 4=-6(LC 16)
Max Grav 1=241(LC 2), 3=241(LC 2), 4=413(LC 2)

FORCES. (lb) - Max. Comp./Max. Ten. - All forces 250 (lb) or less except when shown.
WEBS 2-4=-271/68

- NOTES-**
- Unbalanced roof live loads have been considered for this design.
 - Wind: ASCE 7-10; Vult=130mph (3-second gust) Vasd=103mph; TC DL=6.0psf; BC DL=6.0psf; h=25ft; Cat. II; Exp B; Enclosed; MWFRS (envelope) gable end zone and C-C Exterior(2) zone; cantilever left and right exposed; end vertical left and right exposed; C-C for members and forces & MWFRS for reactions shown; Lumber DOL=1.60 plate grip DOL=1.60
 - TCLL: ASCE 7-10; Pr=30.0 psf (roof live load: Lumber DOL=1.15 Plate DOL=1.15); Pg=30.0 psf (ground snow); Pf=23.1 psf (flat roof snow: Lumber DOL=1.15 Plate DOL=1.15); Category II; Exp B; Partially Exp.; Ct=1.10
 - Unbalanced snow loads have been considered for this design.
 - Gable requires continuous bottom chord bearing.
 - This truss has been designed for a 10.0 psf bottom chord live load nonconcurrent with any other live loads.
 - * This truss has been designed for a live load of 20.0psf on the bottom chord in all areas where a rectangle 3-6-0 tall by 2-0-0 wide will fit between the bottom chord and any other members.
 - Provide mechanical connection (by others) of truss to bearing plate capable of withstanding 100 lb uplift at joint(s) 1, 3, 4.
 - This truss is designed in accordance with the 2015 International Residential Code sections R502.11.1 and R802.10.2 and referenced standard ANSI/TPI 1.

LOAD CASE(S) Standard

Job	Truss	Truss Type	Qty	Ply	GARY ROBINSON-LOT 73 SOUTH CREEK WOODLAKE MODEL ROOF
20-6466-A	V02	Valley	1	1	Job Reference (optional)

Riverside Roof Truss, LLC, Danville, VA. 24541

Run: 8.330 s Feb 24 2020 Print: 8.330 s Feb 24 2020 MiTek Industries, Inc. Wed Nov 11 16:38:59 2020 Page 1
ID:riFrQwqzJQyesEOjBg_H7VvyKEle-TQnaQpGSz?04RwL06iaFeul1v9wtdKREaf7aZSyKCyA

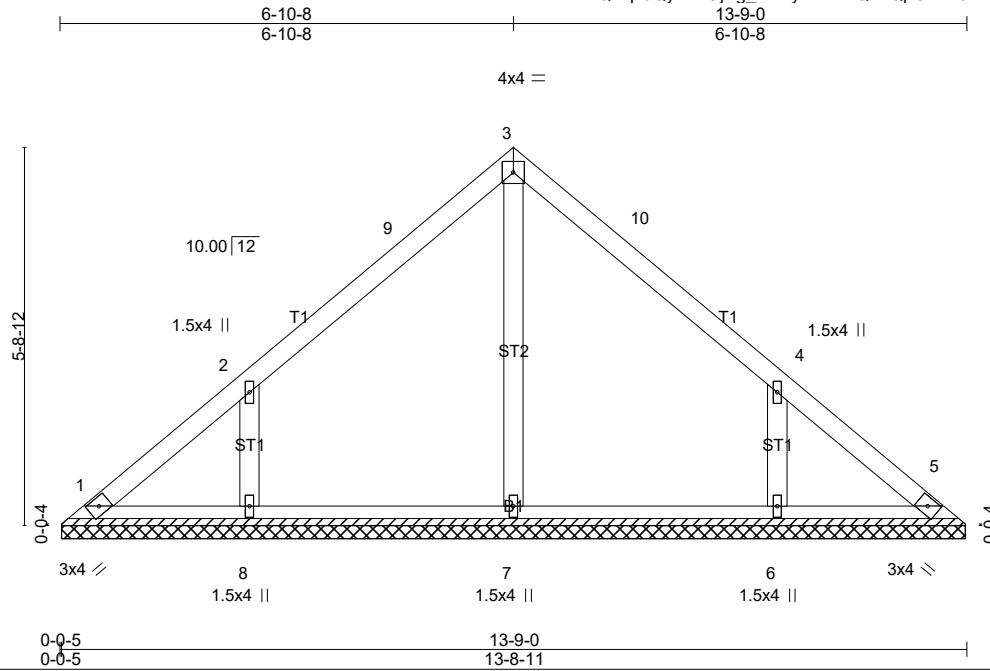

Scale = 1:34.9

LOADING (psf)	SPACING-	CSI.	DEFL.	PLATES	GRIP
TCLL (roof) 30.0	2-0-0	TC 0.24	in (loc) l/defl L/d	MT20	244/190
Snow (Pf/Pg) 23.1/30.0	Plate Grip DOL 1.15	BC 0.12	Vert(LL) n/a - n/a 999		
TCDL 10.0	Lumber DOL 1.15	WB 0.12	Vert(CT) n/a - n/a 999		
BCDL 0.0 *	Rep Stress Incr YES	Matrix-S	Horz(CT) 0.00 5 n/a n/a		
BCLL 0.0	Code IRC2015/TPI2014			Weight: 59 lb	FT = 20%
BCDL 10.0					

LUMBER-
TOP CHORD 2x4 SP No.2
BOT CHORD 2x4 SP No.2
OTHERS 2x4 SP No.3

BRACING-
TOP CHORD Structural wood sheathing directly applied or 6-0-0 oc purlins.
BOT CHORD Rigid ceiling directly applied or 10-0-0 oc bracing.

MiTek recommends that Stabilizers and required cross bracing be installed during truss erection, in accordance with Stabilizer Installation guide.

REACTIONS. All bearings 13-8-6.
(lb) - Max Horz 1=-133(LC 12)
Max Uplift All uplift 100 lb or less at joint(s) 1, 5 except 8=-169(LC 16), 6=-169(LC 17)
Max Grav All reactions 250 lb or less at joint(s) 1, 5 except 7=296(LC 2), 8=398(LC 29), 6=398(LC 30)

FORCES. (lb) - Max. Comp./Max. Ten. - All forces 250 (lb) or less except when shown.
WEBS 2-8=-325/210, 4-6=-325/210

- NOTES-**
- Unbalanced roof live loads have been considered for this design.
 - Wind: ASCE 7-10; Vult=130mph (3-second gust) Vasd=103mph; TC DL=6.0psf; BC DL=6.0psf; h=25ft; Cat. II; Exp B; Enclosed; MWFRS (envelope) gable end zone and C-C Exterior(2) zone; cantilever left and right exposed; end vertical left and right exposed; C-C for members and forces & MWFRS for reactions shown; Lumber DOL=1.60 plate grip DOL=1.60
 - TCLL: ASCE 7-10; Pr=30.0 psf (roof live load: Lumber DOL=1.15 Plate DOL=1.15); Pg=30.0 psf (ground snow); Pf=23.1 psf (flat roof snow: Lumber DOL=1.15 Plate DOL=1.15); Category II; Exp B; Partially Exp.; Ct=1.10
 - Unbalanced snow loads have been considered for this design.
 - Gable requires continuous bottom chord bearing.
 - This truss has been designed for a 10.0 psf bottom chord live load nonconcurrent with any other live loads.
 - * This truss has been designed for a live load of 20.0psf on the bottom chord in all areas where a rectangle 3-6-0 tall by 2-0-0 wide will fit between the bottom chord and any other members.
 - Provide mechanical connection (by others) of truss to bearing plate capable of withstanding 100 lb uplift at joint(s) 1, 5 except (jt=lb) 8=169, 6=169.
 - This truss is designed in accordance with the 2015 International Residential Code sections R502.11.1 and R802.10.2 and referenced standard ANSI/TPI 1.

LOAD CASE(S) Standard

Job 20-6466-A	Truss V01	Truss Type Valley	Qty 1	Ply 1	GARY ROBINSON-LOT 73 SOUTH CREEK WOODLAKE MODEL ROOF Job Reference (optional)
------------------	--------------	----------------------	----------	----------	--

Riverside Roof Truss, LLC, Danville, VA. 24541

Run: 8.330 s Feb 24 2020 Print: 8.330 s Feb 24 2020 MiTek Industries, Inc. Wed Nov 11 16:38:59 2020 Page 1
ID:riFrQwqzJQyesEOjBg_H7VyKEle-TQnaQpGSz?04RwL06iaFeul?I9vydJWEaf7aZSyKCyA

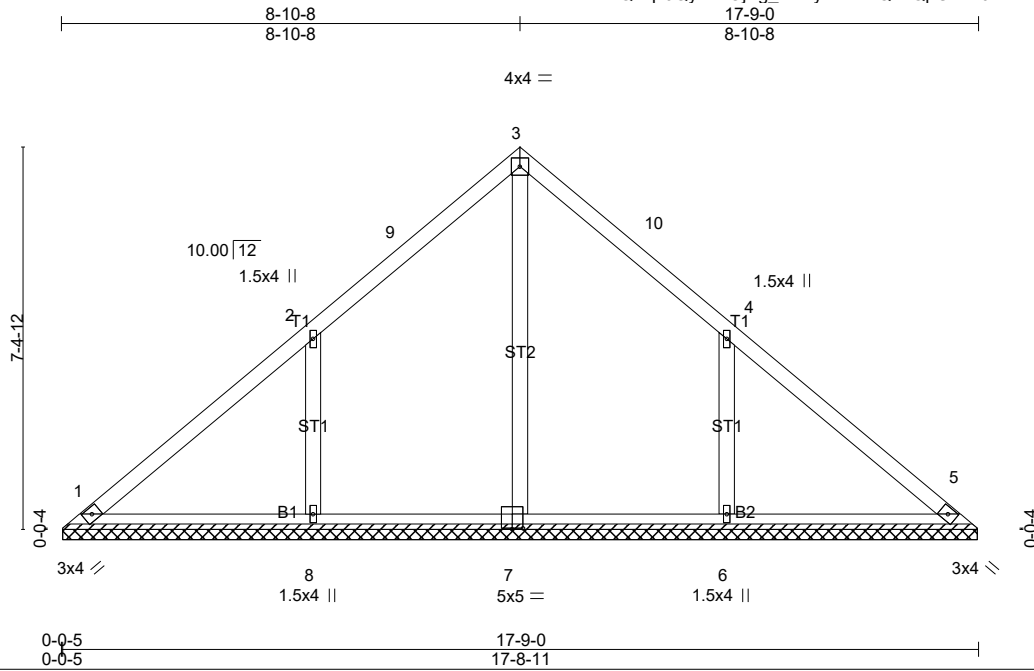

Scale = 1:44.6

Plate Offsets (X,Y)-- [7:0-2-8,0-0-4]

LOADING (psf)		SPACING-		CSI.		DEFL.				PLATES	GRIP
TCLL (roof)	30.0	2-0-0		TC	0.34	in	(loc)	l/defl	L/d	MT20	244/190
Snow (Pf/Pg)	23.1/30.0	Plate Grip DOL	1.15	BC	0.18	Vert(LL)	n/a	-	n/a		
TCDL	10.0	Lumber DOL	1.15	WB	0.18	Vert(CT)	n/a	-	n/a		
BCLL	0.0 *	Rep Stress Incr	YES	Matrix-S		Horz(CT)	0.00	5	n/a		
BCDL	10.0	Code IRC2015/TPI2014								Weight: 80 lb	FT = 20%

LUMBER-
TOP CHORD 2x4 SP No.2
BOT CHORD 2x4 SP No.2
OTHERS 2x4 SP No.3

BRACING-
TOP CHORD Structural wood sheathing directly applied or 6-0-0 oc purlins.
BOT CHORD Rigid ceiling directly applied or 10-0-0 oc bracing.

MiTek recommends that Stabilizers and required cross bracing be installed during truss erection, in accordance with Stabilizer Installation guide.

REACTIONS. All bearings 17-8-6.
(lb) - Max Horz 1=-175(LC 12)
Max Uplift All uplift 100 lb or less at joint(s) 1 except 8=-218(LC 16), 6=-215(LC 17)
Max Grav All reactions 250 lb or less at joint(s) 1, 5 except 7=395(LC 32), 8=574(LC 29), 6=585(LC 30)

FORCES. (lb) - Max. Comp./Max. Ten. - All forces 250 (lb) or less except when shown.
WEBS 2-8=-412/263, 4-6=-412/263

- NOTES-**
- 1) Unbalanced roof live loads have been considered for this design.
 - 2) Wind: ASCE 7-10; Vult=130mph (3-second gust) Vasd=103mph; TCCL=6.0psf; BCDL=6.0psf; h=25ft; Cat. II; Exp B; Enclosed; MWFRS (envelope) gable end zone and C-C Exterior(2) zone; cantilever left and right exposed; end vertical left and right exposed; C-C for members and forces & MWFRS for reactions shown; Lumber DOL=1.60 plate grip DOL=1.60
 - 3) TCCL: ASCE 7-10; Pr=30.0 psf (roof live load); Lumber DOL=1.15 Plate DOL=1.15; Pg=30.0 psf (ground snow); Pf=23.1 psf (flat roof snow); Lumber DOL=1.15 Plate DOL=1.15; Category II; Exp B; Partially Exp.; Ct=1.10
 - 4) Unbalanced snow loads have been considered for this design.
 - 5) Gable requires continuous bottom chord bearing.
 - 6) This truss has been designed for a 10.0 psf bottom chord live load nonconcurrent with any other live loads.
 - 7) * This truss has been designed for a live load of 20.0psf on the bottom chord in all areas where a rectangle 3-6-0 tall by 2-0-0 wide will fit between the bottom chord and any other members, with BCDL = 10.0psf.
 - 8) Provide mechanical connection (by others) of truss to bearing plate capable of withstanding 100 lb uplift at joint(s) 1 except (jt=lb) 8=218, 6=215.
 - 9) This truss is designed in accordance with the 2015 International Residential Code sections R502.11.1 and R802.10.2 and referenced standard ANSI/TPI 1.

LOAD CASE(S) Standard

Job 20-6466-A	Truss TG03	Truss Type ATTIC GIRDER	Qty 2	Ply 3	GARY ROBINSON-LOT 73 SOUTH CREEK WOODLAKE MODEL ROOF
------------------	---------------	----------------------------	----------	----------	--

Riverside Roof Truss, LLC, Danville, VA. 24541

Run: 8.330 s Feb 24 2020 Print: 8.330 s Feb 24 2020 MiTek Industries, Inc. Wed Nov 11 16:39:01 2020 Page 1
ID:riFrQwqzJQyesEOjBg_H7VvyKEle-PovKrViiUdGohEUPD7ckjJNDyySM54IX2zchdLyKCy8

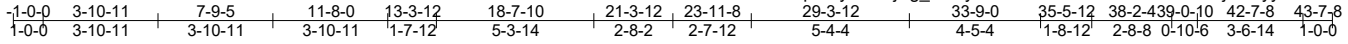

Scale = 1:77.9

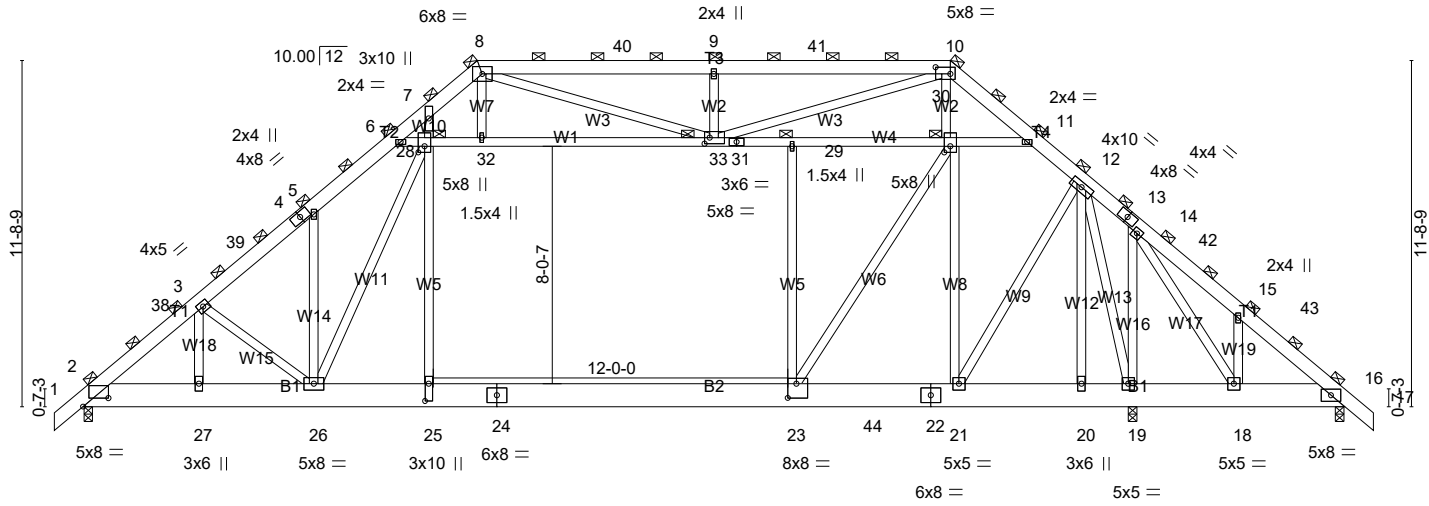

Plate Offsets (X,Y)-- [2:0-10-5,0-3-7], [10:0-6,0-2-12], [23:0-3-8,0-5-12], [25:0-7-0,0-1-8], [28:0-2-8,0-2-8], [30:0-2-8,0-2-8], [33:0-2-0,0-2-8]
--

LOADING (psf)	SPACING-	CSI.	DEFL.	PLATES	GRIP
TCLL (roof) 30.0	5-3-0	TC 0.78	in (loc) l/defl L/d	MT20	244/190
Snow (Pf/Pg) 23.1/30.0	Plate Grip DOL 1.15	BC 0.76	Vert(LL) -0.14 23-25 >999 360		
TCDL 10.0	Lumber DOL 1.15	WB 0.71	Vert(CT) -0.29 23-25 >999 240		
BCLL 0.0 *	Rep Stress Incr NO	Matrix-MS	Horz(CT) 0.05 16 n/a n/a		
BCDL 10.0	Code IRC2015/TPI2014		Attic -0.09 23-25 1694 360	Weight: 1484 lb	FT = 20%

LUMBER-	BRACING-
TOP CHORD 2x6 SP No.2	TOP CHORD 2-0-0 oc purlins (6-0-0 max.)
BOT CHORD 2x10 SP DSS *Except* B2: 2x10 SP No.1	(Switched from sheeted: Spacing > 2-0-0).
WEBS 2x4 SP No.3 *Except* W5,W1,W4: 2x4 SP No.2	BOT CHORD Rigid ceiling directly applied or 10-0-0 oc bracing.
	JOINTS 1 Brace at Jt(s): 8, 10, 28, 29, 30, 33

REACTIONS. (lb/size) 2=8182/0-3-8 (min. 0-3-2), 19=3173/0-3-8 (min. 0-1-8), 16=3405/0-3-8 (min. 0-1-8)
Max Horz 2=-779(LC 14)
Max Uplift 19=-1077(LC 17)
Max Grav 2=9211(LC 46), 19=4655(LC 58), 16=3996(LC 40)

FORCES. (lb) - Max. Comp./Max. Ten. - All forces 250 (lb) or less except when shown.
TOP CHORD 2-38=-12522/0, 3-38=-12164/0, 3-39=-11194/0, 4-39=-10734/0, 4-5=-10539/0,
5-6=-10715/0, 6-7=-7349/0, 7-8=-5666/42, 8-40=-7743/872, 9-40=-7743/872,
9-41=-7743/872, 10-41=-7743/872, 10-11=-4432/0, 11-12=-5773/0, 12-13=-5323/0,
13-14=-5358/0, 14-42=-4789/0, 15-42=-5206/0, 15-43=-4709/0, 16-43=-4972/0
BOT CHORD 2-27=0/9943, 26-27=0/9943, 25-26=0/7299, 24-25=0/7299, 23-24=0/7299, 23-44=0/4931,
22-44=0/4931, 21-22=0/4931, 20-21=0/3996, 19-20=0/3996, 18-19=0/3790, 16-18=0/3755
WEBS 3-27=0/1169, 3-26=-1869/0, 5-26=-715/595, 25-28=0/2571, 23-29=-934/0, 23-30=0/4444,
21-30=-2905/0, 12-21=-69/2643, 12-20=-506/523, 6-28=-4936/0, 28-32=-3604/0,
32-33=-3582/0, 31-33=-4787/0, 29-31=-4787/0, 29-30=-4787/0, 11-30=-2685/0,
10-30=-266/1628, 8-32=0/920, 9-33=-2835/664, 8-33=-1407/2956, 10-33=-906/5043,
14-19=-1659/391, 15-18=-863/511, 12-19=-2242/733, 14-18=-654/227, 7-28=0/3685,
26-28=0/3902

- NOTES-**
- 3-ply truss to be connected together with 10d (0.131"x3") nails as follows:
Top chords connected as follows: 2x6 - 2 rows staggered at 0-9-0 oc.
Bottom chords connected as follows: 2x10 - 2 rows staggered at 0-9-0 oc.
Webs connected as follows: 2x4 - 1 row at 0-9-0 oc.
 - All loads are considered equally applied to all plies, except if noted as front (F) or back (B) face in the LOAD CASE(S) section. Ply to ply connections have been provided to distribute only loads noted as (F) or (B), unless otherwise indicated.
 - Unbalanced roof live loads have been considered for this design.
 - Wind: ASCE 7-10; Vult=130mph (3-second gust) Vasd=103mph; TCCL=6.0psf; BCDL=6.0psf; h=25ft; Cat. II; Exp B; Enclosed; MWFRS (envelope) gable end zone and C-C Exterior(2) zone; cantilever left and right exposed ; end vertical left and right exposed; C-C for members and forces & MWFRS for reactions shown; Lumber DOL=1.60 plate grip DOL=1.60
 - TCCL: ASCE 7-10; Pr=30.0 psf (roof live load: Lumber DOL=1.15 Plate DOL=1.15); Pg=30.0 psf (ground snow); Pf=23.1 psf (flat roof snow: Lumber DOL=1.15 Plate DOL=1.15); Category II; Exp B; Partially Exp.; Ct=1.10, Lu=50-0-0
 - Unbalanced snow loads have been considered for this design.
 - This truss has been designed for greater of min roof live load of 12.0 psf or 1.00 times flat roof load of 23.1 psf on overhangs non-concurrent with other live loads.
 - Provide adequate drainage to prevent water ponding.

Continued on page 2

Job	Truss	Truss Type	Qty	Ply	GARY ROBINSON-LOT 73 SOUTH CREEK WOODLAKE MODEL ROOF
20-6466-A	TG03	ATTIC GIRDER	2	3	Job Reference (optional)

Riverside Roof Truss, LLC, Danville, VA. 24541

Run: 8.330 s Feb 24 2020 Print: 8.330 s Feb 24 2020 MiTek Industries, Inc. Wed Nov 11 16:39:01 2020 Page 2
ID:riFrQwqzJQyesEOjBg_H7VyKEle-PovKrVliUdGohEUPD7ckjJNDyySM54IX2zchdLyKCy8

NOTES-

- 9) This truss has been designed for a 10.0 psf bottom chord live load nonconcurrent with any other live loads.
- 10) * This truss has been designed for a live load of 20.0psf on the bottom chord in all areas where a rectangle 3-6-0 tall by 2-0-0 wide will fit between the bottom chord and any other members, with BCDL = 10.0psf.
- 11) Ceiling dead load (5.0 psf) on member(s). 6-28, 28-32, 32-33, 29-33, 29-30, 11-30; Wall dead load (5.0psf) on member(s).25-28, 23-29
- 12) Bottom chord live load (40.0 psf) and additional bottom chord dead load (5.0 psf) applied only to room. 23-25
- 13) Provide mechanical connection (by others) of truss to bearing plate capable of withstanding 100 lb uplift at joint(s) except (jt=lb) 19=1077.
- 14) This truss is designed in accordance with the 2015 International Residential Code sections R502.11.1 and R802.10.2 and referenced standard ANSI/TPI 1.
- 15) Load case(s) 1, 2, 3, 4, 5, 6, 7, 8, 9, 10, 11, 12, 13, 14, 15, 16, 17, 18, 19, 20, 21, 22, 23, 24, 25, 26, 27, 28, 29, 30, 31, 32, 33, 34, 35, 36, 37, 38, 39, 40, 41, 42, 43, 44, 45, 46, 47, 48, 49, 50, 51, 52, 53, 54, 55, 56, 57, 58, 59, 60, 61, 62, 63, 64, 65, 66, 67, 68, 69, 70, 71, 72, 73, 74, 75, 76, 77, 78, 79, 80, 81, 82, 83, 84, 85, 86, 87, 88 has/have been modified. Building designer must review loads to verify that they are correct for the intended use of this truss.
- 16) Attic room checked for L/360 deflection.

LOAD CASE(S) Standard

- 1) Dead + Snow (balanced): Lumber Increase=1.15, Plate Increase=1.15
Uniform Loads (plf)
Vert: 8-10=-174, 10-17=-174, 6-11=-26, 2-25=-289(F=-237), 23-25=-79, 16-23=-53
Drag: 25-28=-26, 23-29=-26
Trapezoidal Loads (plf)
Vert: 1=-264-to-8=-174
- 2) Dead + Roof Live (balanced): Lumber Increase=1.15, Plate Increase=1.15
Uniform Loads (plf)
Vert: 8-10=-210, 10-17=-210, 6-11=-26, 2-25=-289(F=-237), 23-25=-79, 16-23=-53
Drag: 25-28=-26, 23-29=-26
Trapezoidal Loads (plf)
Vert: 1=-300-to-8=-210
- 3) Dead + 0.75 Roof Live (balanced) + 0.75 Uninhab. Attic Storage + 0.75 Attic Floor: Lumber Increase=1.15, Plate Increase=1.15
Uniform Loads (plf)
Vert: 8-10=-171, 10-17=-171, 6-11=-26, 2-25=-289(F=-237), 23-25=-236, 23-44=-53, 21-44=-131, 16-21=-53
Drag: 25-28=-26, 23-29=-26
Trapezoidal Loads (plf)
Vert: 1=-261-to-8=-171
- 4) Dead + 0.75 Snow (balanced) + 0.75 Uninhab. Attic Storage + 0.75 Attic Floor: Lumber Increase=1.15, Plate Increase=1.15
Uniform Loads (plf)
Vert: 8-10=-143, 10-17=-143, 6-11=-26, 2-25=-289(F=-237), 23-25=-236, 23-44=-53, 21-44=-131, 16-21=-53
Drag: 25-28=-26, 23-29=-26
Trapezoidal Loads (plf)
Vert: 1=-233-to-8=-143
- 5) Dead + 0.75 Snow (Unbal. Left) + 0.75 Uninhab. Attic Storage + 0.75 Attic Floor: Lumber Increase=1.15, Plate Increase=1.15
Uniform Loads (plf)
Vert: 8-41=-143, 10-41=-195, 10-17=-80, 6-11=-26, 2-25=-289(F=-237), 23-25=-236, 23-44=-53, 21-44=-131, 16-21=-53
Drag: 25-28=-26, 23-29=-26
Trapezoidal Loads (plf)
Vert: 1=-233-to-8=-143
- 6) Dead + 0.75 Snow (Unbal. Right) + 0.75 Uninhab. Attic Storage + 0.75 Attic Floor: Lumber Increase=1.15, Plate Increase=1.15
Uniform Loads (plf)
Vert: 8-40=-195, 10-40=-143, 10-17=-143, 6-11=-26, 2-25=-289(F=-237), 23-25=-236, 23-44=-53, 21-44=-131, 16-21=-53
Drag: 25-28=-26, 23-29=-26
Trapezoidal Loads (plf)
Vert: 1=-170-to-8=-80
- 7) Dead + Uninhabitable Attic Without Storage: Lumber Increase=1.25, Plate Increase=1.25
Uniform Loads (plf)
Vert: 8-10=-53, 10-17=-52, 6-11=-26, 2-35=-342(F=-237), 25-35=-342(F=-237), 23-25=-79, 23-37=-105, 16-37=-105
Drag: 25-28=-26, 23-29=-26
Trapezoidal Loads (plf)
Vert: 1=-143-to-8=-53
- 8) Dead + 0.6 C-C Wind (Pos. Internal) Case 1: Lumber Increase=1.60, Plate Increase=1.60
Uniform Loads (plf)
Vert: 8-10=72, 10-16=64, 16-17=50, 6-11=-16, 2-25=-268(F=-237), 23-25=-47, 16-23=-32
Horz: 1-2=-146, 2-8=-96, 10-16=96, 16-17=81
Drag: 25-28=-26, 23-29=-26
Trapezoidal Loads (plf)
Vert: 1=25-to-2=31, 2=-20-to-8=64
- 9) Dead + 0.6 C-C Wind (Pos. Internal) Case 2: Lumber Increase=1.60, Plate Increase=1.60
Uniform Loads (plf)
Vert: 8-10=72, 10-16=64, 16-17=115, 6-11=-16, 2-25=-268(F=-237), 23-25=-47, 16-23=-32
Horz: 1-2=-81, 2-8=-96, 10-16=96, 16-17=146
Drag: 25-28=-26, 23-29=-26
Trapezoidal Loads (plf)
Vert: 1=40-to-2=-34, 2=-20-to-8=64
- 10) Dead + 0.6 C-C Wind (Neg. Internal) Case 1: Lumber Increase=1.60, Plate Increase=1.60
Uniform Loads (plf)
Vert: 8-10=-83, 10-16=-132, 16-17=-117, 6-11=-26, 2-25=-289(F=-237), 23-25=-79, 16-23=-53
Horz: 1-2=-65, 2-8=80, 10-16=-80, 16-17=-65
Drag: 25-28=-26, 23-29=-26
Trapezoidal Loads (plf)
Vert: 1=-78-to-2=-71, 2=-216-to-8=-132
- 11) Dead + 0.6 C-C Wind (Neg. Internal) Case 2: Lumber Increase=1.60, Plate Increase=1.60

Job	Truss	Truss Type	Qty	Ply	GARY ROBINSON-LOT 73 SOUTH CREEK WOODLAKE MODEL ROOF
20-6466-A	TG03	ATTIC GIRDER	2	3	Job Reference (optional)

Riverside Roof Truss, LLC, Danville, VA. 24541

Run: 8.330 s Feb 24 2020 Print: 8.330 s Feb 24 2020 MiTek Industries, Inc. Wed Nov 11 16:39:01 2020 Page 3
ID:riFrQwqzJQyEsEOjBg_H7VyKEle-PovKrVliUdGohEUPD7ckjJNDyySM54IX2zchdLyKCy8

LOAD CASE(S) Standard

Uniform Loads (plf)

Vert: 8-10=-83, 10-16=-132, 16-17=12, 6-11=-26, 2-25=-289(F=-237), 23-25=-79, 16-23=-53
Horz: 1-2=65, 2-8=80, 10-16=-80, 16-17=65
Drag: 25-28=-26, 23-29=-26

Trapezoidal Loads (plf)

Vert: 1=-207-to-2=-201, 2=-216-to-8=-132

12) Dead + 0.6 MWFRS Wind (Pos. Internal) Left: Lumber Increase=1.60, Plate Increase=1.60

Uniform Loads (plf)

Vert: 8-10=70, 10-16=26, 16-17=12, 6-11=-16, 2-25=-268(F=-237), 23-25=-47, 16-23=-32
Horz: 1-2=-26, 2-8=7, 10-16=58, 16-17=43
Drag: 25-28=-26, 23-29=-26

Trapezoidal Loads (plf)

Vert: 1=-95-to-2=-89, 2=-123-to-8=-39

13) Dead + 0.6 MWFRS Wind (Pos. Internal) Right: Lumber Increase=1.60, Plate Increase=1.60

Uniform Loads (plf)

Vert: 8-10=70, 10-16=-39, 16-17=-5, 6-11=-16, 2-25=-268(F=-237), 23-25=-47, 16-23=-32
Horz: 1-2=-43, 2-8=-58, 10-16=-7, 16-17=26
Drag: 25-28=-26, 23-29=-26

Trapezoidal Loads (plf)

Vert: 1=-78-to-2=-72, 2=-58-to-8=26

14) Dead + 0.6 MWFRS Wind (Neg. Internal) Left: Lumber Increase=1.60, Plate Increase=1.60

Uniform Loads (plf)

Vert: 8-10=20, 10-16=-24, 16-17=-9, 6-11=-26, 2-25=-289(F=-237), 23-25=-79, 16-23=-53
Horz: 1-2=22, 2-8=37, 10-16=28, 16-17=43
Drag: 25-28=-26, 23-29=-26

Trapezoidal Loads (plf)

Vert: 1=-164-to-2=-158, 2=-173-to-8=-89

15) Dead + 0.6 MWFRS Wind (Neg. Internal) Right: Lumber Increase=1.60, Plate Increase=1.60

Uniform Loads (plf)

Vert: 8-10=20, 10-16=-89, 16-17=-74, 6-11=-26, 2-25=-289(F=-237), 23-25=-79, 16-23=-53
Horz: 1-2=-43, 2-8=-28, 10-16=-37, 16-17=-22
Drag: 25-28=-26, 23-29=-26

Trapezoidal Loads (plf)

Vert: 1=-99-to-2=-93, 2=-108-to-8=-24

16) Dead + 0.6 MWFRS Wind (Pos. Internal) 1st Parallel: Lumber Increase=1.60, Plate Increase=1.60

Uniform Loads (plf)

Vert: 8-9=70, 9-10=26, 10-16=26, 16-17=12, 6-11=-16, 2-25=-268(F=-237), 23-25=-47, 16-23=-32
Horz: 1-2=-87, 2-8=-101, 10-16=58, 16-17=43
Drag: 25-28=-26, 23-29=-26

Trapezoidal Loads (plf)

Vert: 1=-35-to-2=-29, 2=-14-to-8=70

17) Dead + 0.6 MWFRS Wind (Pos. Internal) 2nd Parallel: Lumber Increase=1.60, Plate Increase=1.60

Uniform Loads (plf)

Vert: 8-9=26, 9-10=70, 10-16=70, 16-17=55, 6-11=-16, 2-25=-268(F=-237), 23-25=-47, 16-23=-32
Horz: 1-2=-43, 2-8=-58, 10-16=101, 16-17=87
Drag: 25-28=-26, 23-29=-26

Trapezoidal Loads (plf)

Vert: 1=-78-to-2=-72, 2=-58-to-8=26

18) Dead + 0.6 MWFRS Wind (Pos. Internal) 3rd Parallel: Lumber Increase=1.60, Plate Increase=1.60

Uniform Loads (plf)

Vert: 8-9=39, 9-10=13, 10-16=13, 16-17=-1, 6-11=-16, 2-25=-268(F=-237), 23-25=-47, 16-23=-32
Horz: 1-2=-56, 2-8=-71, 10-16=45, 16-17=30
Drag: 25-28=-26, 23-29=-26

Trapezoidal Loads (plf)

Vert: 1=-66-to-2=-59, 2=-45-to-8=39

19) Dead + 0.6 MWFRS Wind (Pos. Internal) 4th Parallel: Lumber Increase=1.60, Plate Increase=1.60

Uniform Loads (plf)

Vert: 8-9=13, 9-10=39, 10-16=39, 16-17=24, 6-11=-16, 2-25=-268(F=-237), 23-25=-47, 16-23=-32
Horz: 1-2=-30, 2-8=-45, 10-16=71, 16-17=56
Drag: 25-28=-26, 23-29=-26

Trapezoidal Loads (plf)

Vert: 1=-91-to-2=-85, 2=-71-to-8=13

20) Dead + 0.6 MWFRS Wind (Neg. Internal) 1st Parallel: Lumber Increase=1.60, Plate Increase=1.60

Uniform Loads (plf)

Vert: 8-9=20, 9-10=-24, 10-16=-24, 16-17=-9, 6-11=-26, 2-25=-289(F=-237), 23-25=-79, 16-23=-53
Horz: 1-2=-87, 2-8=-72, 10-16=28, 16-17=43
Drag: 25-28=-26, 23-29=-26

Trapezoidal Loads (plf)

Vert: 1=-56-to-2=-50, 2=-64-to-8=20

21) Dead + 0.6 MWFRS Wind (Neg. Internal) 2nd Parallel: Lumber Increase=1.60, Plate Increase=1.60

Uniform Loads (plf)

Vert: 8-9=-24, 9-10=20, 10-16=20, 16-17=34, 6-11=-26, 2-25=-289(F=-237), 23-25=-79, 16-23=-53
Horz: 1-2=-43, 2-8=-28, 10-16=72, 16-17=87
Drag: 25-28=-26, 23-29=-26

Trapezoidal Loads (plf)

Vert: 1=-99-to-2=-93, 2=-108-to-8=-24

22) Dead + Snow on Overhangs: Lumber Increase=1.15, Plate Increase=1.15

Job	Truss	Truss Type	Qty	Ply	GARY ROBINSON-LOT 73 SOUTH CREEK WOODLAKE MODEL ROOF
20-6466-A	TG03	ATTIC GIRDER	2	3	Job Reference (optional)

Riverside Roof Truss, LLC, Danville, VA. 24541

Run: 8.330 s Feb 24 2020 Print: 8.330 s Feb 24 2020 MiTek Industries, Inc. Wed Nov 11 16:39:01 2020 Page 4
ID:riFrQwqzJQyesEOjBg_H7VyKEle-PovKrVliUdGohEUPD7ckjJNDyySM54IX2zchdLyKCy8

LOAD CASE(S) Standard

Uniform Loads (plf)

Vert: 8-10=-53, 10-16=-52, 16-17=-174, 2-25=-289(F=-237), 23-25=-79, 16-23=-53

Trapezoidal Loads (plf)

Vert: 1=-264-to-2=-258, 2=-136-to-8=-53

23) Dead + Uninhab. Attic Storage + Attic Floor: Lumber Increase=1.00, Plate Increase=1.00

Uniform Loads (plf)

Vert: 8-10=-53, 10-17=-52, 6-11=-26, 2-25=-289(F=-237), 23-25=-289, 23-44=-53, 21-44=-158, 16-21=-53

Drag: 25-28=-26, 23-29=-26

Trapezoidal Loads (plf)

Vert: 1=-143-to-8=-53

24) Dead + Snow (Unbal. Left): Lumber Increase=1.15, Plate Increase=1.15

Uniform Loads (plf)

Vert: 8-41=-174, 10-41=-242, 10-17=-89, 6-11=-26, 2-25=-289(F=-237), 23-25=-79, 16-23=-53

Drag: 25-28=-26, 23-29=-26

Trapezoidal Loads (plf)

Vert: 1=-264-to-8=-174

25) Dead + Snow (Unbal. Right): Lumber Increase=1.15, Plate Increase=1.15

Uniform Loads (plf)

Vert: 8-40=-242, 10-40=-174, 10-17=-174, 6-11=-26, 2-25=-289(F=-237), 23-25=-79, 16-23=-53

Drag: 25-28=-26, 23-29=-26

Trapezoidal Loads (plf)

Vert: 1=-179-to-8=-89

26) Dead + Uninhabitable Attic Storage: Lumber Increase=1.00, Plate Increase=1.00

Uniform Loads (plf)

Vert: 8-10=-53, 10-17=-52, 6-11=-26, 2-25=-289(F=-237), 23-25=-289, 23-44=-53, 21-44=-158, 16-21=-53

Drag: 25-28=-26, 23-29=-26

Trapezoidal Loads (plf)

Vert: 1=-143-to-8=-53

27) Dead + 0.75 Snow (bal.) + 0.75 Uninhab. Attic Storage + 0.75 Attic Floor + 0.75(0.6 MWFRS Wind (Neg. Int) Left): Lumber Increase=1.60, Plate Increase=1.60

Uniform Loads (plf)

Vert: 8-10=-89, 10-16=-122, 16-17=-111, 6-11=-26, 2-25=-289(F=-237), 23-25=-236, 23-44=-53, 21-44=-131, 16-21=-53

Horz: 1-2=16, 2-8=27, 10-16=21, 16-17=32

Drag: 25-28=-26, 23-29=-26

Trapezoidal Loads (plf)

Vert: 1=-250-to-2=-244, 2=-255-to-8=-171

28) Dead + 0.75 Snow (bal.) + 0.75 Uninhab. Attic Storage + 0.75 Attic Floor + 0.75(0.6 MWFRS Wind (Neg. Int) Right): Lumber Increase=1.60, Plate Increase=1.60

Uniform Loads (plf)

Vert: 8-10=-89, 10-16=-171, 16-17=-160, 6-11=-26, 2-25=-289(F=-237), 23-25=-236, 23-44=-53, 21-44=-131, 16-21=-53

Horz: 1-2=-32, 2-8=-21, 10-16=-27, 16-17=-16

Drag: 25-28=-26, 23-29=-26

Trapezoidal Loads (plf)

Vert: 1=-201-to-2=-195, 2=-206-to-8=-122

29) Dead + 0.75 Snow (bal.) + 0.75 Uninhab. Attic Storage + 0.75 Attic Floor + 0.75(0.6 MWFRS Wind (Neg. Int) 1st Parallel): Lumber Increase=1.60, Plate Increase=1.60

Uniform Loads (plf)

Vert: 8-9=-89, 9-10=-122, 10-16=-122, 16-17=-111, 6-11=-26, 2-25=-289(F=-237), 23-25=-236, 23-44=-53, 21-44=-131, 16-21=-53

Horz: 1-2=-65, 2-8=-54, 10-16=21, 16-17=32

Drag: 25-28=-26, 23-29=-26

Trapezoidal Loads (plf)

Vert: 1=-168-to-2=-162, 2=-173-to-8=-89

30) Dead + 0.75 Snow (bal.) + 0.75 Uninhab. Attic Storage + 0.75 Attic Floor + 0.75(0.6 MWFRS Wind (Neg. Int) 2nd Parallel): Lumber Increase=1.60, Plate Increase=1.60

Uniform Loads (plf)

Vert: 8-9=-122, 9-10=-89, 10-16=-89, 16-17=-78, 6-11=-26, 2-25=-289(F=-237), 23-25=-236, 23-44=-53, 21-44=-131, 16-21=-53

Horz: 1-2=-32, 2-8=-21, 10-16=54, 16-17=65

Drag: 25-28=-26, 23-29=-26

Trapezoidal Loads (plf)

Vert: 1=-201-to-2=-195, 2=-206-to-8=-122

31) Dead + 0.75 Roof Live (bal.) + 0.75 Uninhab. Attic Storage + 0.75 Attic Floor + 0.75(0.6 MWFRS Wind (Neg. Int) Left): Lumber Increase=1.60, Plate Increase=1.60

Uniform Loads (plf)

Vert: 8-10=-116, 10-16=-149, 16-17=-138, 6-11=-26, 2-25=-289(F=-237), 23-25=-236, 23-44=-53, 21-44=-131, 16-21=-53

Horz: 1-2=16, 2-8=27, 10-16=21, 16-17=32

Drag: 25-28=-26, 23-29=-26

Trapezoidal Loads (plf)

Vert: 1=-277-to-2=-271, 2=-282-to-8=-198

32) Dead + 0.75 Roof Live (bal.) + 0.75 Uninhab. Attic Storage + 0.75 Attic Floor + 0.75(0.6 MWFRS Wind (Neg. Int) Right): Lumber Increase=1.60, Plate Increase=1.60

Uniform Loads (plf)

Vert: 8-10=-116, 10-16=-198, 16-17=-187, 6-11=-26, 2-25=-289(F=-237), 23-25=-236, 23-44=-53, 21-44=-131, 16-21=-53

Horz: 1-2=-32, 2-8=-21, 10-16=-27, 16-17=-16

Drag: 25-28=-26, 23-29=-26

Trapezoidal Loads (plf)

Vert: 1=-228-to-2=-222, 2=-233-to-8=-149

33) Dead + 0.75 Roof Live (bal.) + 0.75 Uninhab. Attic Storage + 0.75 Attic Floor + 0.75(0.6 MWFRS Wind (Neg. Int) 1st Parallel): Lumber Increase=1.60, Plate Increase=1.60

Uniform Loads (plf)

Vert: 8-10=-116, 10-16=-198, 16-17=-187, 6-11=-26, 2-25=-289(F=-237), 23-25=-236, 23-44=-53, 21-44=-131, 16-21=-53

Horz: 1-2=-32, 2-8=-21, 10-16=-27, 16-17=-16

Drag: 25-28=-26, 23-29=-26

Trapezoidal Loads (plf)

Vert: 1=-228-to-2=-222, 2=-233-to-8=-149

33) Dead + 0.75 Roof Live (bal.) + 0.75 Uninhab. Attic Storage + 0.75 Attic Floor + 0.75(0.6 MWFRS Wind (Neg. Int) 1st Parallel): Lumber Increase=1.60, Plate Increase=1.60

Job	Truss	Truss Type	Qty	Ply	GARY ROBINSON-LOT 73 SOUTH CREEK WOODLAKE MODEL ROOF
20-6466-A	TG03	ATTIC GIRDER	2	3	Job Reference (optional)

Riverside Roof Truss, LLC, Danville, VA. 24541

Run: 8.330 s Feb 24 2020 Print: 8.330 s Feb 24 2020 MiTek Industries, Inc. Wed Nov 11 16:39:01 2020 Page 5
ID:riFrQwqzJQyesEOjBg_H7VyKEle-PovKrVliUdGohEUPD7ckJNDyySM54IX2zchdLyKCy8

LOAD CASE(S) Standard

Uniform Loads (plf)

Vert: 8-9=-116, 9-10=-149, 10-16=-149, 16-17=-138, 6-11=-26, 2-25=-289(F=-237), 23-25=-236, 23-44=-53, 21-44=-131, 16-21=-53
 Horz: 1-2=-65, 2-8=-54, 10-16=21, 16-17=32
 Drag: 25-28=-26, 23-29=-26

Trapezoidal Loads (plf)

Vert: 1=-195-to-2=-189, 2=-200-to-8=-116

34) Dead + 0.75 Roof Live (bal.) + 0.75 Uninhab. Attic Storage + 0.75 Attic Floor + 0.75(0.6 MWFRS Wind (Neg. Int) 2nd Parallel): Lumber Increase=1.60, Plate Increase=1.60

Uniform Loads (plf)

Vert: 8-9=-149, 9-10=-116, 10-16=-116, 16-17=-105, 6-11=-26, 2-25=-289(F=-237), 23-25=-236, 23-44=-53, 21-44=-131, 16-21=-53
 Horz: 1-2=-32, 2-8=-21, 10-16=54, 16-17=65
 Drag: 25-28=-26, 23-29=-26

Trapezoidal Loads (plf)

Vert: 1=-228-to-2=-222, 2=-233-to-8=-149

35) 3rd Dead + 0.75 Snow (Unbal. Left) + 0.75 Uninhab. Attic Storage + 0.75 Attic Floor: Lumber Increase=1.15, Plate Increase=1.15

Uniform Loads (plf)

Vert: 8-41=-143, 10-41=-195, 10-17=-80, 6-11=-26, 2-25=-289(F=-237), 23-25=-236, 23-44=-53, 21-44=-131, 16-21=-53
 Drag: 25-28=-26, 23-29=-26

Trapezoidal Loads (plf)

Vert: 1=-170-to-8=-80

36) 4th Dead + 0.75 Snow (Unbal. Left) + 0.75 Uninhab. Attic Storage + 0.75 Attic Floor: Lumber Increase=1.15, Plate Increase=1.15

Uniform Loads (plf)

Vert: 8-10=-80, 10-17=-80, 6-11=-26, 2-25=-289(F=-237), 23-25=-236, 23-44=-53, 21-44=-131, 16-21=-53
 Drag: 25-28=-26, 23-29=-26

Trapezoidal Loads (plf)

Vert: 1=-233-to-39=-192, 39=-277-to-8=-228

37) 5th Dead + 0.75 Snow (Unbal. Right) + 0.75 Uninhab. Attic Storage + 0.75 Attic Floor: Lumber Increase=1.15, Plate Increase=1.15

Uniform Loads (plf)

Vert: 8-40=-195, 10-40=-143, 10-17=-80, 6-11=-26, 2-25=-289(F=-237), 23-25=-236, 23-44=-53, 21-44=-131, 16-21=-53
 Drag: 25-28=-26, 23-29=-26

Trapezoidal Loads (plf)

Vert: 1=-170-to-8=-80

38) 6th Dead + 0.75 Snow (Unbal. Right) + 0.75 Uninhab. Attic Storage + 0.75 Attic Floor: Lumber Increase=1.15, Plate Increase=1.15

Uniform Loads (plf)

Vert: 8-10=-80, 10-42=-229, 17-42=-143, 6-11=-26, 2-25=-289(F=-237), 23-25=-236, 23-44=-53, 21-44=-131, 16-21=-53
 Drag: 25-28=-26, 23-29=-26

Trapezoidal Loads (plf)

Vert: 1=-170-to-8=-80

39) 7th Unbal. Dead + Snow (balanced) + Parallel: Lumber Increase=1.15, Plate Increase=1.15

Uniform Loads (plf)

Vert: 8-10=-324, 10-17=-89, 6-11=-26, 2-25=-289(F=-237), 23-25=-79, 16-23=-53
 Drag: 25-28=-26, 23-29=-26

Trapezoidal Loads (plf)

Vert: 1=-179-to-8=-89

40) 8th Unbal. Dead + Snow (balanced) + Parallel: Lumber Increase=1.15, Plate Increase=1.15

Uniform Loads (plf)

Vert: 8-10=-89, 10-43=-324, 17-43=-174, 6-11=-26, 2-25=-289(F=-237), 23-25=-79, 16-23=-53
 Drag: 25-28=-26, 23-29=-26

Trapezoidal Loads (plf)

Vert: 1=-264-to-38=-238, 38=-389-to-8=-324

41) 9th Unbal. Dead + Snow (Unbal. Left) + Parallel: Lumber Increase=1.15, Plate Increase=1.15

Uniform Loads (plf)

Vert: 8-41=-174, 10-41=-242, 10-17=-89, 6-11=-26, 2-25=-289(F=-237), 23-25=-79, 16-23=-53
 Drag: 25-28=-26, 23-29=-26

Trapezoidal Loads (plf)

Vert: 1=-179-to-8=-89

42) 10th Unbal. Dead + Snow (Unbal. Left) + Parallel: Lumber Increase=1.15, Plate Increase=1.15

Uniform Loads (plf)

Vert: 8-10=-89, 10-17=-89, 6-11=-26, 2-25=-289(F=-237), 23-25=-79, 16-23=-53
 Drag: 25-28=-26, 23-29=-26

Trapezoidal Loads (plf)

Vert: 1=-264-to-39=-222, 39=-335-to-8=-287

43) 11th Unbal. Dead + Snow (Unbal. Right) + Parallel: Lumber Increase=1.15, Plate Increase=1.15

Uniform Loads (plf)

Vert: 8-40=-242, 10-40=-174, 10-17=-89, 6-11=-26, 2-25=-289(F=-237), 23-25=-79, 16-23=-53
 Drag: 25-28=-26, 23-29=-26

Trapezoidal Loads (plf)

Vert: 1=-179-to-8=-89

44) 12th Unbal. Dead + Snow (Unbal. Right) + Parallel: Lumber Increase=1.15, Plate Increase=1.15

Uniform Loads (plf)

Vert: 8-10=-89, 10-42=-287, 17-42=-174, 6-11=-26, 2-25=-289(F=-237), 23-25=-79, 16-23=-53
 Drag: 25-28=-26, 23-29=-26

Trapezoidal Loads (plf)

Vert: 1=-179-to-8=-89

45) 13th Unbal. Dead + 0.75 Snow (balanced) + 0.75 Uninhab. Attic Storage + 0.75 Attic Floor + Parallel: Lumber Increase=1.15, Plate Increase=1.15

Job	Truss	Truss Type	Qty	Ply	Job Reference (optional)
20-6466-A	TG03	ATTIC GIRDER	2	3	GARY ROBINSON-LOT 73 SOUTH CREEK WOODLAKE MODEL ROOF

Riverside Roof Truss, LLC, Danville, VA. 24541

Run: 8.330 s Feb 24 2020 Print: 8.330 s Feb 24 2020 MiTek Industries, Inc. Wed Nov 11 16:39:01 2020 Page 6
ID:riFrQwqzJQyesEOjBg_H7VyKEle-PovKrVliUdGohEUPD7ckjJNDyySM54IX2zchdLyKCy8

LOAD CASE(S) Standard

Uniform Loads (plf)

Vert: 8-10=-256, 10-17=-80, 6-11=-26, 2-25=-289(F=-237), 23-25=-236, 23-44=-53, 21-44=-131, 16-21=-53
 Drag: 25-28=-26, 23-29=-26

Trapezoidal Loads (plf)

Vert: 1=-170-to-8=-80

46) 14th Unbal.Death + 0.75 Snow (balanced) + 0.75 Uninhab. Attic Storage + 0.75 Attic Floor + Parallel: Lumber Increase=1.15, Plate Increase=1.15

Uniform Loads (plf)

Vert: 8-10=-80, 10-43=-256, 17-43=-143, 6-11=-26, 2-25=-289(F=-237), 23-25=-236, 23-44=-53, 21-44=-131, 16-21=-53
 Drag: 25-28=-26, 23-29=-26

Trapezoidal Loads (plf)

Vert: 1=-233-to-38=-208, 38=-321-to-8=-256

47) 15th Unbal.Death + 0.75 Snow (unbal.) + 0.75 Uninhab. Attic Storage + 0.75 Attic Floor + 0.75(0.6 MWFRS Wind (Neg. Int) Left) + Parallel: Lumber Increase=1.60, Plate Increase=1.60

Uniform Loads (plf)

Vert: 8-10=-202, 10-16=-58, 16-17=-48, 6-11=-26, 2-25=-289(F=-237), 23-25=-236, 23-44=-53, 21-44=-131, 16-21=-53
 Horz: 1-2=16, 2-8=27, 10-16=21, 16-17=32
 Drag: 25-28=-26, 23-29=-26

Trapezoidal Loads (plf)

Vert: 1=-186-to-2=-180, 2=-191-to-8=-107

48) 16th Unbal.Death + 0.75 Snow (unbal.) + 0.75 Uninhab. Attic Storage + 0.75 Attic Floor + 0.75(0.6 MWFRS Wind (Neg. Int) Left) + Parallel: Lumber Increase=1.60, Plate Increase=1.60

Uniform Loads (plf)

Vert: 8-10=-26, 10-43=-235, 16-43=-122, 16-17=-111, 6-11=-26, 2-25=-289(F=-237), 23-25=-236, 23-44=-53, 21-44=-131, 16-21=-53
 Horz: 1-2=16, 2-8=27, 10-16=21, 16-17=32
 Drag: 25-28=-26, 23-29=-26

Trapezoidal Loads (plf)

Vert: 1=-250-to-2=-244, 2=-255-to-38=-235, 38=-348-to-8=-284

49) 17th Unbal.Death + 0.75 Snow (unbal.) + 0.75 Uninhab. Attic Storage + 0.75 Attic Floor + 0.75(0.6 MWFRS Wind (Neg. Int) Right) + Parallel: Lumber Increase=1.60, Plate Increase=1.60

Uniform Loads (plf)

Vert: 8-10=-202, 10-16=-107, 16-17=-96, 6-11=-26, 2-25=-289(F=-237), 23-25=-236, 23-44=-53, 21-44=-131, 16-21=-53
 Horz: 1-2=-32, 2-8=-21, 10-16=-27, 16-17=-16
 Drag: 25-28=-26, 23-29=-26

Trapezoidal Loads (plf)

Vert: 1=-138-to-2=-131, 2=-142-to-8=-58

50) 18th Unbal.Death + 0.75 Snow (unbal.) + 0.75 Uninhab. Attic Storage + 0.75 Attic Floor + 0.75(0.6 MWFRS Wind (Neg. Int) Right) + Parallel: Lumber Increase=1.60, Plate Increase=1.60

Uniform Loads (plf)

Vert: 8-10=-26, 10-43=-284, 16-43=-171, 16-17=-160, 6-11=-26, 2-25=-289(F=-237), 23-25=-236, 23-44=-53, 21-44=-131, 16-21=-53
 Horz: 1-2=-32, 2-8=-21, 10-16=-27, 16-17=-16
 Drag: 25-28=-26, 23-29=-26

Trapezoidal Loads (plf)

Vert: 1=-201-to-2=-195, 2=-206-to-38=-186, 38=-299-to-8=-235

51) 19th Unbal.Death + 0.75 Snow (unbal.) + 0.75 Uninhab. Attic Storage + 0.75 Attic Floor + 0.75(0.6 MWFRS Wind (Neg. Int) 1st Parallel): Lumber Increase=1.60, Plate Increase=1.60

Uniform Loads (plf)

Vert: 8-9=-202, 9-10=-235, 10-16=-58, 16-17=-48, 6-11=-26, 2-25=-289(F=-237), 23-25=-236, 23-44=-53, 21-44=-131, 16-21=-53
 Horz: 1-2=-65, 2-8=-54, 10-16=21, 16-17=32
 Drag: 25-28=-26, 23-29=-26

Trapezoidal Loads (plf)

Vert: 1=-105-to-2=-99, 2=-110-to-8=-26

52) 20th Unbal.Death + 0.75 Snow (unbal.) + 0.75 Uninhab. Attic Storage + 0.75 Attic Floor + 0.75(0.6 MWFRS Wind (Neg. Int) 1st Parallel): Lumber Increase=1.60, Plate Increase=1.60

Uniform Loads (plf)

Vert: 8-9=-26, 9-10=-58, 10-43=-235, 16-43=-122, 16-17=-111, 6-11=-26, 2-25=-289(F=-237), 23-25=-236, 23-44=-53, 21-44=-131, 16-21=-53
 Horz: 1-2=-65, 2-8=-54, 10-16=21, 16-17=32
 Drag: 25-28=-26, 23-29=-26

Trapezoidal Loads (plf)

Vert: 1=-168-to-2=-162, 2=-173-to-38=-153, 38=-266-to-8=-202

53) 21st Unbal.Death + 0.75 Snow (unbal.) + 0.75 Uninhab. Attic Storage + 0.75 Attic Floor + 0.75(0.6 MWFRS Wind (Neg. Int) 2nd Parallel): Lumber Increase=1.60, Plate Increase=1.60

Uniform Loads (plf)

Vert: 8-9=-235, 9-10=-202, 10-16=-26, 16-17=-15, 6-11=-26, 2-25=-289(F=-237), 23-25=-236, 23-44=-53, 21-44=-131, 16-21=-53
 Horz: 1-2=-32, 2-8=-21, 10-16=54, 16-17=65
 Drag: 25-28=-26, 23-29=-26

Trapezoidal Loads (plf)

Vert: 1=-138-to-2=-131, 2=-142-to-8=-58

54) 22nd Unbal.Death + 0.75 Snow (unbal.) + 0.75 Uninhab. Attic Storage + 0.75 Attic Floor + 0.75(0.6 MWFRS Wind (Neg. Int) 2nd Parallel): Lumber Increase=1.60, Plate Increase=1.60

Job	Truss	Truss Type	Qty	Ply	GARY ROBINSON-LOT 73 SOUTH CREEK WOODLAKE MODEL ROOF
20-6466-A	TG03	ATTIC GIRDER	2	3	Job Reference (optional)

Riverside Roof Truss, LLC, Danville, VA. 24541

Run: 8.330 s Feb 24 2020 Print: 8.330 s Feb 24 2020 MiTek Industries, Inc. Wed Nov 11 16:39:01 2020 Page 7
ID:riFrQwqzJQyEsEOjBg_H7VyKEle-PovKrVliUdGohEUPD7ckjJNDySM54IX2zchdLyKCy8

LOAD CASE(S) Standard

Uniform Loads (plf)

Vert: 8-9=-58, 9-10=-26, 10-43=-202, 16-43=-89, 16-17=-78, 6-11=-26, 2-25=-289(F=-237), 23-25=-236, 23-44=-53, 21-44=-131, 16-21=-53
 Horz: 1-2=-32, 2-8=-21, 10-16=54, 16-17=65
 Drag: 25-28=-26, 23-29=-26

Trapezoidal Loads (plf)

Vert: 1=-201-to-2=-195, 2=-206-to-38=-186, 38=-299-to-8=-235

55) 1st Dead + Roof Live (unbalanced): Lumber Increase=1.15, Plate Increase=1.15

Uniform Loads (plf)

Vert: 8-10=-210, 10-17=-52, 6-11=-26, 2-25=-289(F=-237), 23-25=-79, 16-23=-53
 Drag: 25-28=-26, 23-29=-26

Trapezoidal Loads (plf)

Vert: 1=-300-to-8=-210

56) 2nd Dead + Roof Live (unbalanced): Lumber Increase=1.15, Plate Increase=1.15

Uniform Loads (plf)

Vert: 8-10=-210, 10-17=-210, 6-11=-26, 2-25=-289(F=-237), 23-25=-79, 16-23=-53
 Drag: 25-28=-26, 23-29=-26

Trapezoidal Loads (plf)

Vert: 1=-143-to-8=-53

57) 3rd Dead + 0.75 Roof Live (unbalanced) + 0.75 Uninhab. Attic Storage + 0.75 Attic Floor: Lumber Increase=1.15, Plate Increase=1.15

Uniform Loads (plf)

Vert: 8-10=-171, 10-17=-52, 6-11=-26, 2-25=-289(F=-237), 23-25=-236, 23-44=-53, 21-44=-131, 16-21=-53
 Drag: 25-28=-26, 23-29=-26

Trapezoidal Loads (plf)

Vert: 1=-261-to-8=-171

58) 4th Dead + 0.75 Roof Live (unbalanced) + 0.75 Uninhab. Attic Storage + 0.75 Attic Floor: Lumber Increase=1.15, Plate Increase=1.15

Uniform Loads (plf)

Vert: 8-10=-171, 10-17=-171, 6-11=-26, 2-25=-289(F=-237), 23-25=-236, 23-44=-53, 21-44=-131, 16-21=-53
 Drag: 25-28=-26, 23-29=-26

Trapezoidal Loads (plf)

Vert: 1=-143-to-8=-53

59) Reversal: Dead + 0.6 C-C Wind (Pos. Internal) Case 1: Lumber Increase=1.60, Plate Increase=1.60

Uniform Loads (plf)

Vert: 8-10=72, 10-16=64, 16-17=50, 6-11=-16, 2-25=-268(F=-237), 23-25=-47, 16-23=-32
 Horz: 1-2=-146, 2-8=-96, 10-16=96, 16-17=81
 Drag: 25-28=-26, 23-29=-26

Trapezoidal Loads (plf)

Vert: 1=25-to-2=31, 2=-20-to-8=64

60) Reversal: Dead + 0.6 C-C Wind (Pos. Internal) Case 2: Lumber Increase=1.60, Plate Increase=1.60

Uniform Loads (plf)

Vert: 8-10=72, 10-16=64, 16-17=115, 6-11=-16, 2-25=-268(F=-237), 23-25=-47, 16-23=-32
 Horz: 1-2=-81, 2-8=-96, 10-16=96, 16-17=146
 Drag: 25-28=-26, 23-29=-26

Trapezoidal Loads (plf)

Vert: 1=-40-to-2=-34, 2=-20-to-8=64

61) Reversal: Dead + 0.6 C-C Wind (Neg. Internal) Case 1: Lumber Increase=1.60, Plate Increase=1.60

Uniform Loads (plf)

Vert: 8-10=-83, 10-16=-132, 16-17=-117, 6-11=-26, 2-25=-289(F=-237), 23-25=-79, 16-23=-53
 Horz: 1-2=-65, 2-8=80, 10-16=-80, 16-17=-65
 Drag: 25-28=-26, 23-29=-26

Trapezoidal Loads (plf)

Vert: 1=-78-to-2=-71, 2=-216-to-8=-132

62) Reversal: Dead + 0.6 C-C Wind (Neg. Internal) Case 2: Lumber Increase=1.60, Plate Increase=1.60

Uniform Loads (plf)

Vert: 8-10=-83, 10-16=-132, 16-17=12, 6-11=-26, 2-25=-289(F=-237), 23-25=-79, 16-23=-53
 Horz: 1-2=65, 2-8=80, 10-16=-80, 16-17=65
 Drag: 25-28=-26, 23-29=-26

Trapezoidal Loads (plf)

Vert: 1=-207-to-2=-201, 2=-216-to-8=-132

63) Reversal: Dead + 0.6 MWFRS Wind (Pos. Internal) Left: Lumber Increase=1.60, Plate Increase=1.60

Uniform Loads (plf)

Vert: 8-10=70, 10-16=26, 16-17=12, 6-11=-16, 2-25=-268(F=-237), 23-25=-47, 16-23=-32
 Horz: 1-2=-26, 2-8=7, 10-16=58, 16-17=43
 Drag: 25-28=-26, 23-29=-26

Trapezoidal Loads (plf)

Vert: 1=-95-to-2=-89, 2=-123-to-8=-39

64) Reversal: Dead + 0.6 MWFRS Wind (Pos. Internal) Right: Lumber Increase=1.60, Plate Increase=1.60

Uniform Loads (plf)

Vert: 8-10=70, 10-16=-39, 16-17=-5, 6-11=-16, 2-25=-268(F=-237), 23-25=-47, 16-23=-32
 Horz: 1-2=43, 2-8=-58, 10-16=-7, 16-17=26
 Drag: 25-28=-26, 23-29=-26

Trapezoidal Loads (plf)

Vert: 1=-78-to-2=-72, 2=-58-to-8=26

65) Reversal: Dead + 0.6 MWFRS Wind (Neg. Internal) Left: Lumber Increase=1.60, Plate Increase=1.60

Job	Truss	Truss Type	Qty	Ply	GARY ROBINSON-LOT 73 SOUTH CREEK WOODLAKE MODEL ROOF
20-6466-A	TG03	ATTIC GIRDER	2	3	Job Reference (optional)

Riverside Roof Truss, LLC, Danville, VA. 24541

Run: 8.330 s Feb 24 2020 Print: 8.330 s Feb 24 2020 MiTek Industries, Inc. Wed Nov 11 16:39:01 2020 Page 8
ID:riFrQwqzJQyesEOjBg_H7VyKEle-PovKrVliUdGohEUPD7ckjJNDyySM54IX2zchdLyKCy8

LOAD CASE(S) Standard

Uniform Loads (plf)

Vert: 8-10=20, 10-16=-24, 16-17=-9, 6-11=-26, 2-25=-289(F=-237), 23-25=-79, 16-23=-53
Horz: 1-2=22, 2-8=37, 10-16=28, 16-17=43
Drag: 25-28=-26, 23-29=-26

Trapezoidal Loads (plf)

Vert: 1=-164-to-2=-158, 2=-173-to-8=-89

66) Reversal: Dead + 0.6 MWFRS Wind (Neg. Internal) Right: Lumber Increase=1.60, Plate Increase=1.60

Uniform Loads (plf)

Vert: 8-10=20, 10-16=-89, 16-17=-74, 6-11=-26, 2-25=-289(F=-237), 23-25=-79, 16-23=-53
Horz: 1-2=-43, 2-8=-28, 10-16=-37, 16-17=-22
Drag: 25-28=-26, 23-29=-26

Trapezoidal Loads (plf)

Vert: 1=-99-to-2=-93, 2=-108-to-8=-24

67) Reversal: Dead + 0.6 MWFRS Wind (Pos. Internal) 1st Parallel: Lumber Increase=1.60, Plate Increase=1.60

Uniform Loads (plf)

Vert: 8-9=70, 9-10=26, 10-16=26, 16-17=12, 6-11=-16, 2-25=-268(F=-237), 23-25=-47, 16-23=-32
Horz: 1-2=-87, 2-8=-101, 10-16=58, 16-17=43
Drag: 25-28=-26, 23-29=-26

Trapezoidal Loads (plf)

Vert: 1=-35-to-2=-29, 2=-14-to-8=70

68) Reversal: Dead + 0.6 MWFRS Wind (Pos. Internal) 2nd Parallel: Lumber Increase=1.60, Plate Increase=1.60

Uniform Loads (plf)

Vert: 8-9=26, 9-10=70, 10-16=70, 16-17=55, 6-11=-16, 2-25=-268(F=-237), 23-25=-47, 16-23=-32
Horz: 1-2=-43, 2-8=-58, 10-16=101, 16-17=87
Drag: 25-28=-26, 23-29=-26

Trapezoidal Loads (plf)

Vert: 1=-78-to-2=-72, 2=-58-to-8=26

69) Reversal: Dead + 0.6 MWFRS Wind (Pos. Internal) 3rd Parallel: Lumber Increase=1.60, Plate Increase=1.60

Uniform Loads (plf)

Vert: 8-9=39, 9-10=13, 10-16=13, 16-17=-1, 6-11=-16, 2-25=-268(F=-237), 23-25=-47, 16-23=-32
Horz: 1-2=-56, 2-8=-71, 10-16=45, 16-17=30
Drag: 25-28=-26, 23-29=-26

Trapezoidal Loads (plf)

Vert: 1=-66-to-2=-59, 2=-45-to-8=39

70) Reversal: Dead + 0.6 MWFRS Wind (Pos. Internal) 4th Parallel: Lumber Increase=1.60, Plate Increase=1.60

Uniform Loads (plf)

Vert: 8-9=13, 9-10=39, 10-16=39, 16-17=24, 6-11=-16, 2-25=-268(F=-237), 23-25=-47, 16-23=-32
Horz: 1-2=-30, 2-8=-45, 10-16=71, 16-17=56
Drag: 25-28=-26, 23-29=-26

Trapezoidal Loads (plf)

Vert: 1=-91-to-2=-85, 2=-71-to-8=13

71) Reversal: Dead + 0.6 MWFRS Wind (Neg. Internal) 1st Parallel: Lumber Increase=1.60, Plate Increase=1.60

Uniform Loads (plf)

Vert: 8-9=20, 9-10=-24, 10-16=-24, 16-17=-9, 6-11=-26, 2-25=-289(F=-237), 23-25=-79, 16-23=-53
Horz: 1-2=-87, 2-8=-72, 10-16=28, 16-17=43
Drag: 25-28=-26, 23-29=-26

Trapezoidal Loads (plf)

Vert: 1=-56-to-2=-50, 2=-64-to-8=20

72) Reversal: Dead + 0.6 MWFRS Wind (Neg. Internal) 2nd Parallel: Lumber Increase=1.60, Plate Increase=1.60

Uniform Loads (plf)

Vert: 8-9=-24, 9-10=20, 10-16=20, 16-17=34, 6-11=-26, 2-25=-289(F=-237), 23-25=-79, 16-23=-53
Horz: 1-2=-43, 2-8=-28, 10-16=72, 16-17=87
Drag: 25-28=-26, 23-29=-26

Trapezoidal Loads (plf)

Vert: 1=-99-to-2=-93, 2=-108-to-8=-24

73) Reversal: Dead + 0.75 Snow (bal.) + 0.75 Uninhab. Attic Storage + 0.75 Attic Floor + 0.75(0.6 MWFRS Wind (Neg. Int) Left): Lumber Increase=1.60, Plate Increase=1.60

Uniform Loads (plf)

Vert: 8-10=-89, 10-16=-122, 16-17=-111, 6-11=-26, 2-25=-289(F=-237), 23-25=-236, 23-44=-53, 21-44=-131, 16-21=-53
Horz: 1-2=16, 2-8=27, 10-16=21, 16-17=32
Drag: 25-28=-26, 23-29=-26

Trapezoidal Loads (plf)

Vert: 1=-250-to-2=-244, 2=-255-to-8=-171

74) Reversal: Dead + 0.75 Snow (bal.) + 0.75 Uninhab. Attic Storage + 0.75 Attic Floor + 0.75(0.6 MWFRS Wind (Neg. Int) Right): Lumber Increase=1.60, Plate Increase=1.60

Uniform Loads (plf)

Vert: 8-10=-89, 10-16=-171, 16-17=-160, 6-11=-26, 2-25=-289(F=-237), 23-25=-236, 23-44=-53, 21-44=-131, 16-21=-53
Horz: 1-2=-32, 2-8=-21, 10-16=-27, 16-17=-16
Drag: 25-28=-26, 23-29=-26

Trapezoidal Loads (plf)

Vert: 1=-201-to-2=-195, 2=-206-to-8=-122

75) Reversal: Dead + 0.75 Snow (bal.) + 0.75 Uninhab. Attic Storage + 0.75 Attic Floor + 0.75(0.6 MWFRS Wind (Neg. Int) 1st Parallel): Lumber Increase=1.60, Plate Increase=1.60

Job	Truss	Truss Type	Qty	Ply	GARY ROBINSON-LOT 73 SOUTH CREEK WOODLAKE MODEL ROOF
20-6466-A	TG03	ATTIC GIRDER	2	3	Job Reference (optional)

Riverside Roof Truss, LLC, Danville, VA. 24541

Run: 8.330 s Feb 24 2020 Print: 8.330 s Feb 24 2020 MiTek Industries, Inc. Wed Nov 11 16:39:01 2020 Page 9
ID:riFrQwqzJQyEsEOjBg_H7VyKEle-PovKrVliUdGohEUPD7ckjJNDyySM54IX2zchdLyKCy8

LOAD CASE(S) Standard

Uniform Loads (plf)

Vert: 8-9=-89, 9-10=-122, 10-16=-122, 16-17=-111, 6-11=-26, 2-25=-289(F=-237), 23-25=-236, 23-44=-53, 21-44=-131, 16-21=-53
Horz: 1-2=-65, 2-8=-54, 10-16=21, 16-17=32
Drag: 25-28=-26, 23-29=-26

Trapezoidal Loads (plf)

Vert: 1=-168-to-2=-162, 2=-173-to-8=-89

76) Reversal: Dead + 0.75 Snow (bal.) + 0.75 Uninhab. Attic Storage + 0.75 Attic Floor + 0.75(0.6 MWFRS Wind (Neg. Int) 2nd Parallel): Lumber Increase=1.60, Plate Increase=1.60

Uniform Loads (plf)

Vert: 8-9=-122, 9-10=-89, 10-16=-89, 16-17=-78, 6-11=-26, 2-25=-289(F=-237), 23-25=-236, 23-44=-53, 21-44=-131, 16-21=-53
Horz: 1-2=-32, 2-8=-21, 10-16=54, 16-17=65
Drag: 25-28=-26, 23-29=-26

Trapezoidal Loads (plf)

Vert: 1=-201-to-2=-195, 2=-206-to-8=-122

77) Reversal: Dead + 0.75 Roof Live (bal.) + 0.75 Uninhab. Attic Storage + 0.75 Attic Floor + 0.75(0.6 MWFRS Wind (Neg. Int) Left): Lumber Increase=1.60, Plate Increase=1.60

Uniform Loads (plf)

Vert: 8-10=-116, 10-16=-149, 16-17=-138, 6-11=-26, 2-25=-289(F=-237), 23-25=-236, 23-44=-53, 21-44=-131, 16-21=-53
Horz: 1-2=16, 2-8=27, 10-16=21, 16-17=32
Drag: 25-28=-26, 23-29=-26

Trapezoidal Loads (plf)

Vert: 1=-277-to-2=-271, 2=-282-to-8=-198

78) Reversal: Dead + 0.75 Roof Live (bal.) + 0.75 Uninhab. Attic Storage + 0.75 Attic Floor + 0.75(0.6 MWFRS Wind (Neg. Int) Right): Lumber Increase=1.60, Plate Increase=1.60

Uniform Loads (plf)

Vert: 8-10=-116, 10-16=-198, 16-17=-187, 6-11=-26, 2-25=-289(F=-237), 23-25=-236, 23-44=-53, 21-44=-131, 16-21=-53
Horz: 1-2=-32, 2-8=-21, 10-16=-27, 16-17=-16
Drag: 25-28=-26, 23-29=-26

Trapezoidal Loads (plf)

Vert: 1=-228-to-2=-222, 2=-233-to-8=-149

79) Reversal: Dead + 0.75 Roof Live (bal.) + 0.75 Uninhab. Attic Storage + 0.75 Attic Floor + 0.75(0.6 MWFRS Wind (Neg. Int) 1st Parallel): Lumber Increase=1.60, Plate Increase=1.60

Uniform Loads (plf)

Vert: 8-9=-116, 9-10=-149, 10-16=-149, 16-17=-138, 6-11=-26, 2-25=-289(F=-237), 23-25=-236, 23-44=-53, 21-44=-131, 16-21=-53
Horz: 1-2=-65, 2-8=-54, 10-16=21, 16-17=32
Drag: 25-28=-26, 23-29=-26

Trapezoidal Loads (plf)

Vert: 1=-195-to-2=-189, 2=-200-to-8=-116

80) Reversal: Dead + 0.75 Roof Live (bal.) + 0.75 Uninhab. Attic Storage + 0.75 Attic Floor + 0.75(0.6 MWFRS Wind (Neg. Int) 2nd Parallel): Lumber Increase=1.60, Plate Increase=1.60

Uniform Loads (plf)

Vert: 8-9=-149, 9-10=-116, 10-16=-116, 16-17=-105, 6-11=-26, 2-25=-289(F=-237), 23-25=-236, 23-44=-53, 21-44=-131, 16-21=-53
Horz: 1-2=-32, 2-8=-21, 10-16=54, 16-17=65
Drag: 25-28=-26, 23-29=-26

Trapezoidal Loads (plf)

Vert: 1=-228-to-2=-222, 2=-233-to-8=-149

81) Reversal: 15th Unbal. Dead + 0.75 Snow (unbal.) + 0.75 Uninhab. Attic Storage + 0.75 Attic Floor + 0.75(0.6 MWFRS Wind (Neg. Int) Left) + Parallel: Lumber Increase=1.60, Plate Increase=1.60

Uniform Loads (plf)

Vert: 8-10=-202, 10-16=-58, 16-17=-48, 6-11=-26, 2-25=-289(F=-237), 23-25=-236, 23-44=-53, 21-44=-131, 16-21=-53
Horz: 1-2=16, 2-8=27, 10-16=21, 16-17=32
Drag: 25-28=-26, 23-29=-26

Trapezoidal Loads (plf)

Vert: 1=-186-to-2=-180, 2=-191-to-8=-107

82) Reversal: 16th Unbal. Dead + 0.75 Snow (unbal.) + 0.75 Uninhab. Attic Storage + 0.75 Attic Floor + 0.75(0.6 MWFRS Wind (Neg. Int) Left) + Parallel: Lumber Increase=1.60, Plate Increase=1.60

Uniform Loads (plf)

Vert: 8-10=-26, 10-43=-235, 16-43=-122, 16-17=-111, 6-11=-26, 2-25=-289(F=-237), 23-25=-236, 23-44=-53, 21-44=-131, 16-21=-53
Horz: 1-2=16, 2-8=27, 10-16=21, 16-17=32
Drag: 25-28=-26, 23-29=-26

Trapezoidal Loads (plf)

Vert: 1=-250-to-2=-244, 2=-255-to-38=-235, 38=-348-to-8=-284

83) Reversal: 17th Unbal. Dead + 0.75 Snow (unbal.) + 0.75 Uninhab. Attic Storage + 0.75 Attic Floor + 0.75(0.6 MWFRS Wind (Neg. Int) Right) + Parallel: Lumber Increase=1.60, Plate Increase=1.60

Uniform Loads (plf)

Vert: 8-10=-202, 10-16=-107, 16-17=-96, 6-11=-26, 2-25=-289(F=-237), 23-25=-236, 23-44=-53, 21-44=-131, 16-21=-53
Horz: 1-2=-32, 2-8=-21, 10-16=-27, 16-17=-16
Drag: 25-28=-26, 23-29=-26

Trapezoidal Loads (plf)

Vert: 1=-138-to-2=-131, 2=-142-to-8=-58

84) Reversal: 18th Unbal. Dead + 0.75 Snow (unbal.) + 0.75 Uninhab. Attic Storage + 0.75 Attic Floor + 0.75(0.6 MWFRS Wind (Neg. Int) Right) + Parallel: Lumber Increase=1.60, Plate Increase=1.60

Job	Truss	Truss Type	Qty	Ply	GARY ROBINSON-LOT 73 SOUTH CREEK WOODLAKE MODEL ROOF
20-6466-A	TG03	ATTIC GIRDER	2	3	Job Reference (optional)

Riverside Roof Truss, LLC, Danville, VA. 24541

Run: 8.330 s Feb 24 2020 Print: 8.330 s Feb 24 2020 MiTek Industries, Inc. Wed Nov 11 16:39:01 2020 Page 10
ID:riFrQwqzJQyesEOjBg_H7VyKEle-PovKrVliUdGohEUPD7ckjJNDyySM54IX2zchdLyKCy8

LOAD CASE(S) Standard

Uniform Loads (plf)

Vert: 8-10=-26, 10-43=-284, 16-43=-171, 16-17=-160, 6-11=-26, 2-25=-289(F=-237), 23-25=-236, 23-44=-53, 21-44=-131, 16-21=-53
Horz: 1-2=-32, 2-8=-21, 10-16=-27, 16-17=-16
Drag: 25-28=-26, 23-29=-26

Trapezoidal Loads (plf)

Vert: 1=-201-to-2=-195, 2=-206-to-38=-186, 38=-299-to-8=-235

85) Reversal: 19th Unbal.Dead + 0.75 Snow (unbal.) + 0.75 Uninhab. Attic Storage + 0.75 Attic Floor + 0.75(0.6 MWFRS Wind (Neg. Int) 1st Parallel): Lumber Increase=1.60, Plate Increase=1.60

Uniform Loads (plf)

Vert: 8-9=-202, 9-10=-235, 10-16=-58, 16-17=-48, 6-11=-26, 2-25=-289(F=-237), 23-25=-236, 23-44=-53, 21-44=-131, 16-21=-53
Horz: 1-2=-65, 2-8=-54, 10-16=21, 16-17=32
Drag: 25-28=-26, 23-29=-26

Trapezoidal Loads (plf)

Vert: 1=-105-to-2=-99, 2=-110-to-8=-26

86) Reversal: 20th Unbal.Dead + 0.75 Snow (unbal.) + 0.75 Uninhab. Attic Storage + 0.75 Attic Floor + 0.75(0.6 MWFRS Wind (Neg. Int) 1st Parallel): Lumber Increase=1.60, Plate Increase=1.60

Uniform Loads (plf)

Vert: 8-9=-26, 9-10=-58, 10-43=-235, 16-43=-122, 16-17=-111, 6-11=-26, 2-25=-289(F=-237), 23-25=-236, 23-44=-53, 21-44=-131, 16-21=-53
Horz: 1-2=-65, 2-8=-54, 10-16=21, 16-17=32
Drag: 25-28=-26, 23-29=-26

Trapezoidal Loads (plf)

Vert: 1=-168-to-2=-162, 2=-173-to-38=-153, 38=-266-to-8=-202

87) Reversal: 21st Unbal.Dead + 0.75 Snow (unbal.) + 0.75 Uninhab. Attic Storage + 0.75 Attic Floor + 0.75(0.6 MWFRS Wind (Neg. Int) 2nd Parallel): Lumber Increase=1.60, Plate Increase=1.60

Uniform Loads (plf)

Vert: 8-9=-235, 9-10=-202, 10-16=-26, 16-17=-15, 6-11=-26, 2-25=-289(F=-237), 23-25=-236, 23-44=-53, 21-44=-131, 16-21=-53
Horz: 1-2=-32, 2-8=-21, 10-16=54, 16-17=65
Drag: 25-28=-26, 23-29=-26

Trapezoidal Loads (plf)

Vert: 1=-138-to-2=-131, 2=-142-to-8=-58

88) Reversal: 22nd Unbal.Dead + 0.75 Snow (unbal.) + 0.75 Uninhab. Attic Storage + 0.75 Attic Floor + 0.75(0.6 MWFRS Wind (Neg. Int) 2nd Parallel): Lumber Increase=1.60, Plate Increase=1.60

Uniform Loads (plf)

Vert: 8-9=-58, 9-10=-26, 10-43=-202, 16-43=-89, 16-17=-78, 6-11=-26, 2-25=-289(F=-237), 23-25=-236, 23-44=-53, 21-44=-131, 16-21=-53
Horz: 1-2=-32, 2-8=-21, 10-16=54, 16-17=65
Drag: 25-28=-26, 23-29=-26

Trapezoidal Loads (plf)

Vert: 1=-201-to-2=-195, 2=-206-to-38=-186, 38=-299-to-8=-235

Job	Truss	Truss Type	Qty	Ply	GARY ROBINSON-LOT 73 SOUTH CREEK WOODLAKE MODEL ROOF
20-6466-A	TG02	ATTIC GIRDER	1	2	Job Reference (optional)

Riverside Roof Truss, LLC, Danville, VA. 24541

Run: 8.330 s Feb 24 2020 Print: 8.330 s Feb 24 2020 MiTek Industries, Inc. Wed Nov 11 16:39:03 2020 Page 1
 ID:riFrQwqzJQyesEOjBg_H7VyKEle-LB14GBJy0EWWwXeoLYeCokSYqmAjZ_IqVH5niDyKCy6

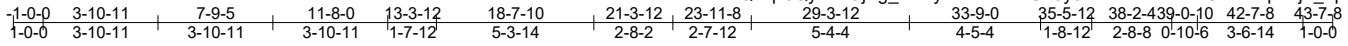

Scale = 1:77.9

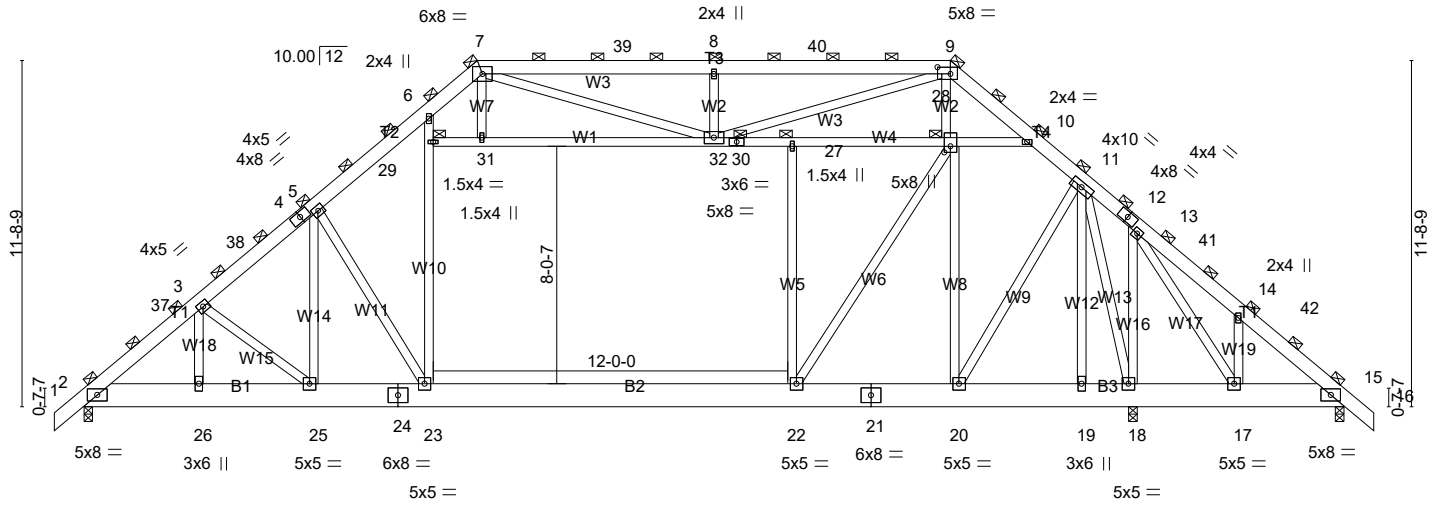

Plate Offsets (X,Y)--	[9:0-5-4,0-2-12], [28:0-2-8,0-2-8]
-----------------------	------------------------------------

LOADING (psf)	SPACING-	CSI.	DEFL.	in (loc)	l/defl	L/d	PLATES	GRIP
TCLL (roof) 30.0	2-8-0	TC 0.88	Vert(LL) -0.18 22-23	>999	360		MT20	244/190
Snow (Pf/Pg) 23.1/30.0	Plate Grip DOL 1.15	BC 0.64	Vert(CT) -0.28 22-23	>999	240			
TCDL 10.0	Lumber DOL 1.15	WB 0.71	Horz(CT) 0.03 15	n/a	n/a			
BCLL 0.0 *	Rep Stress Incr NO	Matrix-MS	Attic -0.09 22-23	1730	360			
BCDL 10.0	Code IRC2015/TPI2014						Weight: 980 lb	FT = 20%

LUMBER-	BRACING-
TOP CHORD 2x6 SP No.2	TOP CHORD 2-0-0 oc purlins (5-3-13 max.)
BOT CHORD 2x10 SP No.2	(Switched from sheeted: Spacing > 2-0-0).
WEBS 2x4 SP No.3 *Except*	BOT CHORD Rigid ceiling directly applied or 10-0-0 oc bracing, Except:
W10,W5,W1,W4: 2x4 SP No.2	6-0-0 oc bracing: 17-18,15-17.
	JOINTS 1 Brace at Jt(s): 7, 9, 27, 28, 29, 32

REACTIONS. (lb/size) 2=2509/0-3-8 (min. 0-1-12), 15=906/0-3-8 (min. 0-1-8), 18=2327/0-3-8 (min. 0-1-14)
 Max Horz 2=-396(LC 14)
 Max Uplift 2=-109(LC 16), 15=-304(LC 16), 18=-89(LC 17)
 Max Grav 2=2979(LC 46), 15=1091(LC 2), 18=3199(LC 58)

FORCES. (lb) - Max. Comp./Max. Ten. - All forces 250 (lb) or less except when shown.
 TOP CHORD 2-37=-4239/159, 3-37=-4149/177, 3-38=-3940/208, 4-38=-3716/208, 4-5=-3711/230,
 5-6=-3734/220, 6-7=-2692/338, 7-39=-3880/541, 8-39=-3880/541, 8-40=-3880/541,
 9-40=-3880/541, 9-10=-2094/44, 10-11=-2205/294, 11-12=-1247/639, 12-13=-1250/623,
 13-41=-986/576, 14-41=-1243/563, 14-42=-1023/470, 15-42=-1119/454
 BOT CHORD 2-26=-203/3378, 25-26=-203/3378, 24-25=-118/3131, 23-24=-118/3131, 22-23=-42/2738,
 21-22=-178/1773, 20-21=-178/1773, 19-20=-274/1067, 18-19=-274/1067, 17-18=-384/849,
 15-17=-333/830
 WEBS 3-25=-325/148, 5-25=-201/528, 5-23=-1331/397, 23-29=0/1857, 6-29=0/1671, 22-27=-387/0,
 22-28=0/1930, 20-28=-1462/4, 11-20=0/1577, 11-19=-534/20, 29-31=-338/0, 31-32=-330/0,
 30-32=-1321/283, 27-30=-1321/283, 27-28=-1321/283, 10-28=-591/403, 9-28=-326/591,
 7-31=0/317, 8-32=-1423/352, 7-32=-624/1648, 9-32=-473/2583, 13-18=-718/302,
 14-17=-447/249, 11-18=-1929/0, 13-17=-262/201

- NOTES-**
- 2-ply truss to be connected together with 10d (0.131"x3") nails as follows:
 Top chords connected as follows: 2x6 - 2 rows staggered at 0-9-0 oc.
 Bottom chords connected as follows: 2x10 - 2 rows staggered at 0-9-0 oc.
 Webs connected as follows: 2x4 - 1 row at 0-9-0 oc.
 - All loads are considered equally applied to all plies, except if noted as front (F) or back (B) face in the LOAD CASE(S) section. Ply to ply connections have been provided to distribute only loads noted as (F) or (B), unless otherwise indicated.
 - Unbalanced roof live loads have been considered for this design.
 - Wind: ASCE 7-10; Vult=130mph (3-second gust) Vasd=103mph; TC DL=6.0psf; BC DL=6.0psf; h=25ft; Cat. II; Exp B; Enclosed; MWFRS (envelope) gable end zone and C-C Exterior(2) zone; cantilever left and right exposed; end vertical left and right exposed; C-C for members and forces & MWFRS for reactions shown; Lumber DOL=1.60 plate grip DOL=1.60
 - TCLL: ASCE 7-10; Pr=30.0 psf (roof live load: Lumber DOL=1.15 Plate DOL=1.15); Pg=30.0 psf (ground snow); Pf=23.1 psf (flat roof snow: Lumber DOL=1.15 Plate DOL=1.15); Category II; Exp B; Partially Exp.; Ct=1.10, Lu=50-0-0
 - Unbalanced snow loads have been considered for this design.
 - This truss has been designed for greater of min roof live load of 12.0 psf or 1.00 times flat roof load of 23.1 psf on overhangs non-concurrent with other live loads.
 - Provide adequate drainage to prevent water ponding.
 - This truss has been designed for a 10.0 psf bottom chord live load nonconcurrent with any other live loads.

Continued on page 2

Job	Truss	Truss Type	Qty	Ply	GARY ROBINSON-LOT 73 SOUTH CREEK WOODLAKE MODEL ROOF
20-6466-A	TG02	ATTIC GIRDER	1	2	Job Reference (optional)

Riverside Roof Truss, LLC, Danville, VA. 24541

Run: 8.330 s Feb 24 2020 Print: 8.330 s Feb 24 2020 MiTek Industries, Inc. Wed Nov 11 16:39:03 2020 Page 2
 ID:riFrQwqzJQyesEOjBg_H7VyKEle-LB14GBJy0EWWwXeoLYeCokSYqmAjZ_lqVH5niDyKCy6

NOTES-

- 10) * This truss has been designed for a live load of 20.0psf on the bottom chord in all areas where a rectangle 3-6-0 tall by 2-0-0 wide will fit between the bottom chord and any other members, with BCDL = 10.0psf.
- 11) Ceiling dead load (5.0 psf) on member(s). 29-31, 31-32, 27-32, 27-28, 10-28; Wall dead load (5.0psf) on member(s).23-29, 22-27
- 12) Bottom chord live load (40.0 psf) and additional bottom chord dead load (5.0 psf) applied only to room. 22-23
- 13) Provide mechanical connection (by others) of truss to bearing plate capable of withstanding 100 lb uplift at joint(s) 18 except (jt=lb) 2=109, 15=304.
- 14) This truss is designed in accordance with the 2015 International Residential Code sections R502.11.1 and R802.10.2 and referenced standard ANSI/TPI 1.
- 15) Graphical purlin representation does not depict the size or the orientation of the purlin along the top and/or bottom chord.
- 16) Attic room checked for L/360 deflection.

LOAD CASE(S) Standard

Job 20-6466-A	Truss TG01	Truss Type ATTIC GIRDER	Qty 1	Ply 2	GARY ROBINSON-LOT 73 SOUTH CREEK WOODLAKE MODEL ROOF
------------------	---------------	----------------------------	----------	----------	--

Riverside Roof Truss, LLC, Danville, VA. 24541

Run: 8.330 s Feb 24 2020 Print: 8.330 s Feb 24 2020 MiTek Industries, Inc. Wed Nov 11 16:39:04 2020 Page 1
ID:riFrQwqzJQyEsEOjBg_H7VyKEle-pNbTTWkanYeNYhD_uF9RLy?juAT5IT8zkrLEfyKCyS

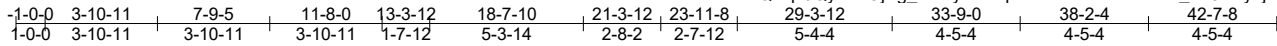

Scale = 1:79.7

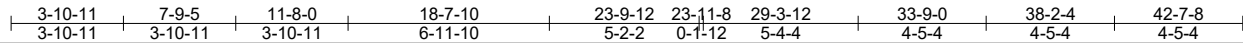
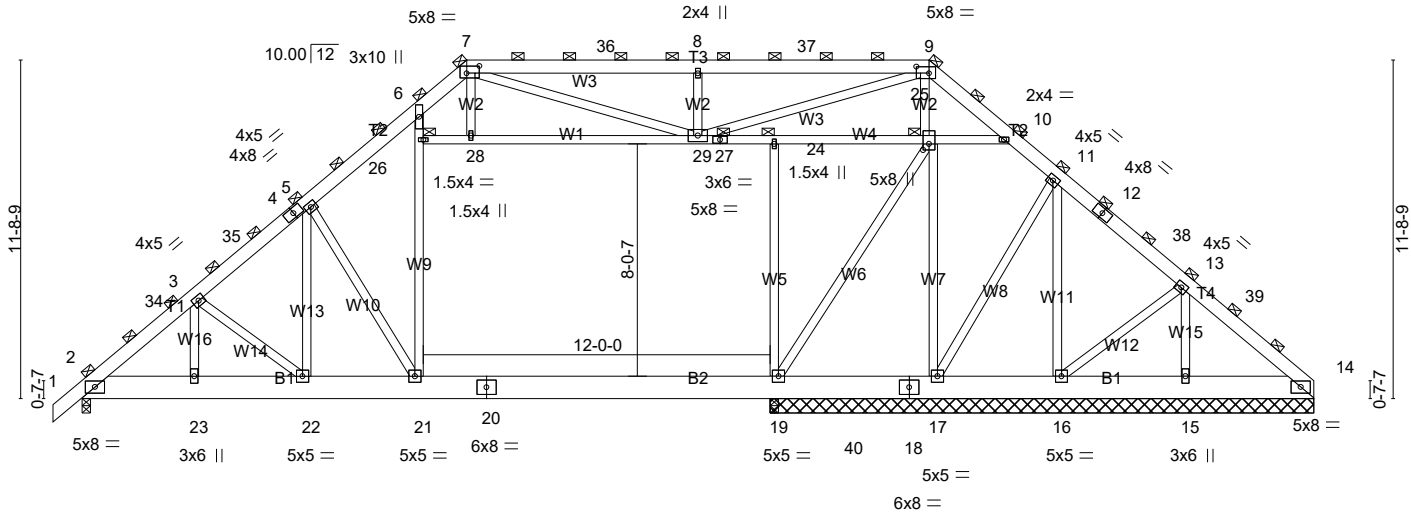

Plate Offsets (X,Y)-- [7:0-5-4,0-3-0], [9:0-5-4,0-2-12], [25:0-2-8,0-2-8]

LOADING (psf)	SPACING-	CSI.	DEFL.	in (loc)	l/defl	L/d	PLATES	GRIP
TCLL (roof) 30.0	Plate Grip DOL 2-8-0	TC 0.86	Vert(LL) -0.18	19-21	>999	360	MT20	244/190
Snow (Pf/Pg) 23.1/30.0	Lumber DOL 1.15	BC 0.76	Vert(CT) -0.28	19-21	>999	240		
TCDL 10.0	Rep Stress Incr NO	WB 0.60	Horz(CT) 0.03	14	n/a	n/a		
BCLL 0.0 *	Code IRC2015/TPI2014	Matrix-MS	Attic -0.10	19-21	1538	360		
BCDL 10.0							Weight: 938 lb	FT = 20%

LUMBER-

TOP CHORD 2x6 SP No.2
 BOT CHORD 2x10 SP No.2
 WEBS 2x4 SP No.3 *Except*
 W9,W5,W1,W4: 2x4 SP No.2

BRACING-

TOP CHORD 2-0-0 oc purlins (5-8-12 max.)
 (Switched from sheeted: Spacing > 2-0-0).
 BOT CHORD Rigid ceiling directly applied or 10-0-0 oc bracing.
 JOINTS 1 Brace at Jt(s): 7, 9, 24, 25, 26, 29

REACTIONS.

All bearings 18-9-12 except (jt=length) 2=0-3-8.
 (lb) - Max Horz 2=386(LC 13)
 Max Uplift All uplift 100 lb or less at joint(s) 16, 15, 14 except 2=-182(LC 16), 17=-270(LC 12)
 Max Grav All reactions 250 lb or less at joint(s) except 2=2834(LC 46), 19=1138(LC 23), 19=251(LC 1), 17=735(LC 39), 16=790(LC 50), 15=1308(LC 40), 14=1079(LC 2)

FORCES. (lb) - Max. Comp./Max. Ten. - All forces 250 (lb) or less except when shown.

TOP CHORD 2-34=-4009/228, 3-34=-3923/246, 3-35=-3725/272, 4-35=-3503/289, 4-5=-3498/293,
 5-6=-3436/303, 6-7=-2565/388, 7-36=-3661/649, 8-36=-3661/649, 8-37=-3661/649,
 9-37=-3661/649, 9-10=-1569/191, 10-11=-2073/282, 11-12=-1857/192, 12-38=-1881/171,
 13-38=-2010/151, 13-39=-1294/89, 14-39=-1466/67
 BOT CHORD 2-23=-309/3215, 22-23=-309/3215, 21-22=-209/2975, 20-21=-159/2493, 19-20=-159/2493,
 19-40=-122/1790, 18-40=-122/1790, 17-18=-122/1790, 16-17=-86/1468, 15-16=-42/1079,
 14-15=-42/1079
 WEBS 3-22=-321/154, 5-22=-129/597, 5-21=-1387/351, 21-26=-14/1746, 6-26=0/1568,
 19-24=-438/0, 19-25=-100/1376, 17-25=-1414/154, 11-17=-71/638, 11-16=-722/97,
 13-16=-57/562, 13-15=-1131/149, 26-28=-290/14, 28-29=-272/16, 27-29=-1383/177,
 24-27=-1383/177, 24-25=-1383/177, 10-25=-695/159, 9-25=-524/429, 7-28=0/313,
 8-29=-1438/350, 7-29=-752/1525, 9-29=-458/2645

NOTES-

- 2-ply truss to be connected together with 10d (0.131"x3") nails as follows:
 Top chords connected as follows: 2x6 - 2 rows staggered at 0-9-0 oc.
 Bottom chords connected as follows: 2x10 - 2 rows staggered at 0-9-0 oc.
 Webs connected as follows: 2x4 - 1 row at 0-9-0 oc.
- All loads are considered equally applied to all plies, except if noted as front (F) or back (B) face in the LOAD CASE(S) section. Ply to ply connections have been provided to distribute only loads noted as (F) or (B), unless otherwise indicated.
- Unbalanced roof live loads have been considered for this design.
- Wind: ASCE 7-10; Vult=130mph (3-second gust) Vasd=103mph; TCCL=6.0psf; BCDL=6.0psf; h=25ft; Cat. II; Exp B; Enclosed; MWFRS (envelope) gable end zone and C-C Exterior(2) zone; cantilever left and right exposed ; end vertical left and right exposed;C-C for members and forces & MWFRS for reactions shown; Lumber DOL=1.60 plate grip DOL=1.60
- TCCL: ASCE 7-10; Pr=30.0 psf (roof live load); Lumber DOL=1.15 Plate DOL=1.15; Pg=30.0 psf (ground snow); Pf=23.1 psf (flat roof snow); Lumber DOL=1.15 Plate DOL=1.15; Category II; Exp B; Partially Exp.; Ct=1.10, Lu=50-0-0
- Unbalanced snow loads have been considered for this design.
- This truss has been designed for greater of min roof live load of 12.0 psf or 1.00 times flat roof load of 23.1 psf on overhangs non-concurrent with other live loads.
- Provide adequate drainage to prevent water ponding.

Continued on page 2

Job	Truss	Truss Type	Qty	Ply	GARY ROBINSON-LOT 73 SOUTH CREEK WOODLAKE MODEL ROOF
20-6466-A	TG01	ATTIC GIRDER	1	2	Job Reference (optional)

Riverside Roof Truss, LLC, Danville, VA. 24541

Run: 8.330 s Feb 24 2020 Print: 8.330 s Feb 24 2020 MiTek Industries, Inc. Wed Nov 11 16:39:04 2020 Page 2
ID:riFrQwqzJQyesEOjBg_H7VyKEle-pNbTTWkanYeNYhD_uF9RLy?juAT5IT8zkxrLEfyKCy5

NOTES-

- 9) This truss has been designed for a 10.0 psf bottom chord live load nonconcurrent with any other live loads.
- 10) * This truss has been designed for a live load of 20.0psf on the bottom chord in all areas where a rectangle 3-6-0 tall by 2-0-0 wide will fit between the bottom chord and any other members, with BCDL = 10.0psf.
- 11) Ceiling dead load (5.0 psf) on member(s). 26-28, 28-29, 24-29, 24-25, 10-25; Wall dead load (5.0psf) on member(s).21-26, 19-24
- 12) Bottom chord live load (40.0 psf) and additional bottom chord dead load (5.0 psf) applied only to room. 19-21
- 13) Provide mechanical connection (by others) of truss to bearing plate capable of withstanding 100 lb uplift at joint(s) 16, 15, 14 except (jt=lb) 2=182, 17=270.
- 14) This truss is designed in accordance with the 2015 International Residential Code sections R502.11.1 and R802.10.2 and referenced standard ANSI/TPI 1.
- 15) Graphical purlin representation does not depict the size or the orientation of the purlin along the top and/or bottom chord.
- 16) Attic room checked for L/360 deflection.

LOAD CASE(S) Standard

Job 20-6466-A	Truss T01GE	Truss Type GABLE	Qty 1	Ply 1	GARY ROBINSON-LOT 73 SOUTH CREEK WOODLAKE MODEL ROOF
Riverside Roof Truss, LLC, Danville, VA. 24541					Job Reference (optional)

Run: 8.330 s Feb 24 2020 Print: 8.330 s Feb 24 2020 MiTek Industries, Inc. Wed Nov 11 16:39:05 2020 Page 1
ID:riFrQwqzJQyesEOjBg_H7VyKEle-Ha8rhsLDYrmEAroASzggT9X4hazY10D7ybaum6yKCy4

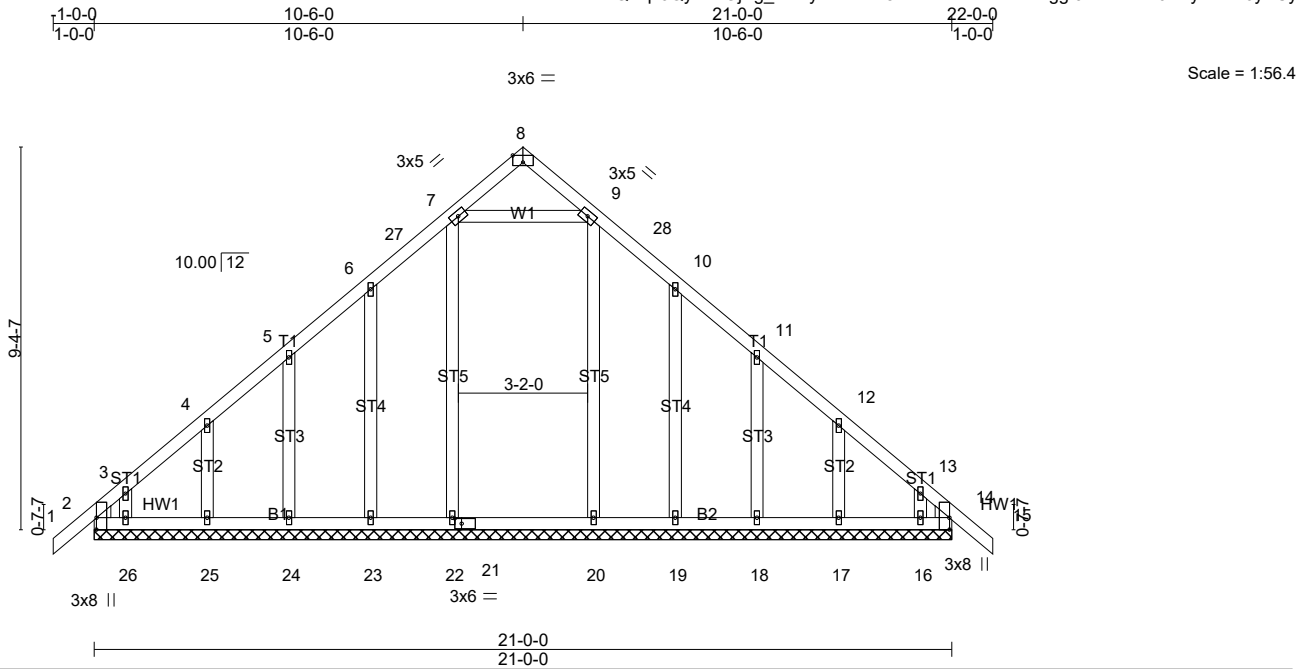

Plate Offsets (X,Y)-- [2:0-3-8,Edge], [2:0-0-10,0-3-9], [2:0-0-5,0-0-6], [8:0-3-0,Edge], [14:0-3-8,Edge], [14:0-0-10,0-3-9], [14:0-0-5,0-0-6], [21:0-2-0,0-1-8]									
LOADING (psf)	SPACING-	2-0-0	CSI.	DEFL.	in (loc)	l/defl	L/d	PLATES	GRIP
TCLL (roof) 30.0	Plate Grip DOL	1.15	TC 0.09	Vert(LL)	-0.00	15	n/r	MT20	244/190
Snow (Pf/Pg) 23.1/30.0	Lumber DOL	1.15	BC 0.10	Vert(CT)	-0.00	15	n/r		
TCDL 10.0	Rep Stress Incr	YES	WB 0.23	Horz(CT)	0.01	14	n/a		
BCLL 0.0 *	Code IRC2015/TPI2014		Matrix-S						
BCDL 10.0								Weight: 142 lb	FT = 20%

LUMBER-	BRACING-
TOP CHORD 2x4 SP No.2	TOP CHORD Structural wood sheathing directly applied or 6-0-0 oc purlins.
BOT CHORD 2x4 SP No.2	BOT CHORD Rigid ceiling directly applied or 10-0-0 oc bracing.
WEBS 2x4 SP No.3	MiTek recommends that Stabilizers and required cross bracing be installed during truss erection, in accordance with Stabilizer Installation guide.
OTHERS 2x4 SP No.3	
WEDGE	
Left: 2x4 SP No.3 , Right: 2x4 SP No.3	

REACTIONS. All bearings 21-0-0.
 (lb) - Max Horz 2=-237(LC 14)
 Max Uplift All uplift 100 lb or less at joint(s) 23, 24, 25, 19, 18, 17, 14, 16 except 2=-128(LC 12), 26=-107(LC 16)
 Max Grav All reactions 250 lb or less at joint(s) 23, 24, 25, 26, 19, 18, 17, 14, 16 except 2=257(LC 31), 22=319(LC 30), 20=294(LC 6)

FORCES. (lb) - Max. Comp./Max. Ten. - All forces 250 (lb) or less except when shown.
 TOP CHORD 2-3=-262/208

- NOTES-**
- Unbalanced roof live loads have been considered for this design.
 - Wind: ASCE 7-10; Vult=130mph (3-second gust) Vasd=103mph; TCDL=6.0psf; BCDL=6.0psf; h=25ft; Cat. II; Exp B; Enclosed; MWFRS (envelope) gable end zone and C-C Exterior(2) zone; cantilever left and right exposed; end vertical left and right exposed; C-C for members and forces & MWFRS for reactions shown; Lumber DOL=1.60 plate grip DOL=1.60
 - Truss designed for wind loads in the plane of the truss only. For studs exposed to wind (normal to the face), see Standard Industry Gable End Details as applicable, or consult qualified building designer as per ANSI/TPI 1.
 - TCLL: ASCE 7-10; Pr=30.0 psf (roof live load: Lumber DOL=1.15 Plate DOL=1.15); Pg=30.0 psf (ground snow); Pf=23.1 psf (flat roof snow: Lumber DOL=1.15 Plate DOL=1.15); Category II; Exp B; Partially Exp.; Ct=1.10
 - Unbalanced snow loads have been considered for this design.
 - This truss has been designed for greater of min roof live load of 12.0 psf or 1.00 times flat roof load of 23.1 psf on overhangs non-concurrent with other live loads.
 - All plates are 1.5x4 MT20 unless otherwise indicated.
 - Gable requires continuous bottom chord bearing.
 - Gable studs spaced at 2-0-0 oc.
 - This truss has been designed for a 10.0 psf bottom chord live load nonconcurrent with any other live loads.
 - * This truss has been designed for a live load of 20.0psf on the bottom chord in all areas where a rectangle 3-6-0 tall by 2-0-0 wide will fit between the bottom chord and any other members, with BCDL = 10.0psf.
 - Provide mechanical connection (by others) of truss to bearing plate capable of withstanding 100 lb uplift at joint(s) 23, 24, 25, 19, 18, 17, 14, 16 except (jt=lb) 2=128, 26=107.
 - This truss is designed in accordance with the 2015 International Residential Code sections R502.11.1 and R802.10.2 and referenced standard ANSI/TPI 1.

LOAD CASE(S) Standard

Job	Truss	Truss Type	Qty	Ply	GARY ROBINSON-LOT 73 SOUTH CREEK WOODLAKE MODEL ROOF
20-6466-A	T01	Common	1	1	Job Reference (optional)

Riverside Roof Truss, LLC, Danville, VA. 24541

Run: 8.330 s Feb 24 2020 Print: 8.330 s Feb 24 2020 MiTek Industries, Inc. Wed Nov 11 16:39:06 2020 Page 1
 ID:riFrQwqzJQyesEOjBg_H7VvyKEle-mmDuCMrJ9u4n?NN0gCvQN49YzCBmRMGBFKSJyYkCy3

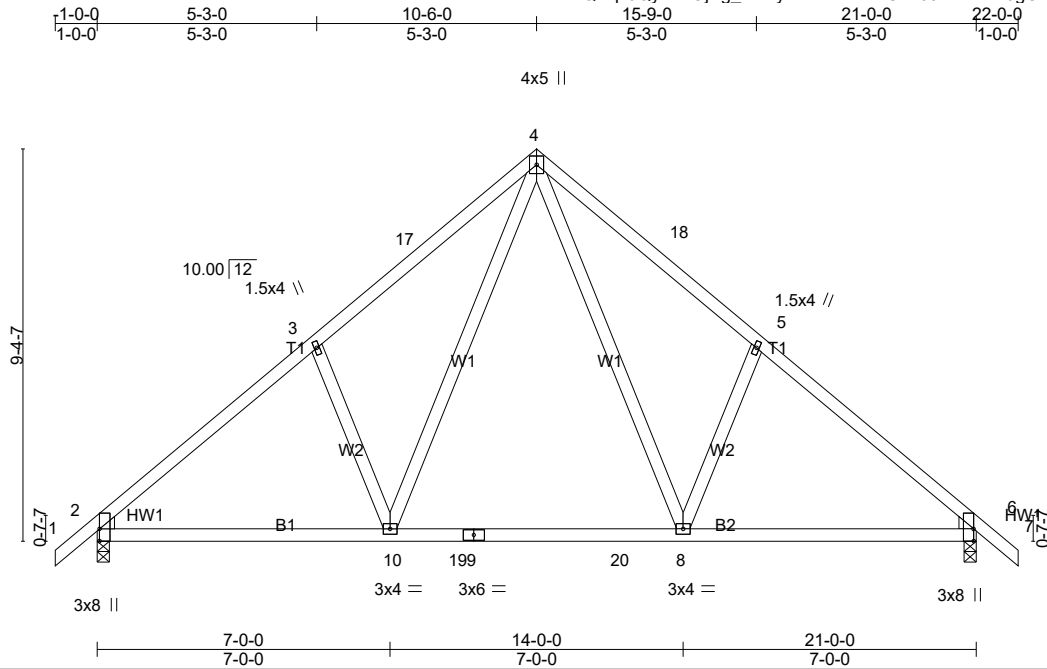

Plate Offsets (X,Y)-- [2:0-0-5,0,0-6], [2:0-0-10,0,3-9], [2:0-3-8,Edge], [6:0-0-5,0,0-6], [6:0-0-10,0,3-9], [6:0-3-8,Edge]

LOADING (psf)	SPACING-	CSI.	DEFL.	PLATES	GRIP
TCLL (roof) 30.0	2-0-0	TC 0.47	in (loc) l/defl L/d	MT20	244/190
Snow (Pf/Pg) 23.1/30.0	Plate Grip DOL 1.15	BC 0.52	Vert(LL) -0.13 8-10 >999 360		
TCDL 10.0	Lumber DOL 1.15	WB 0.30	Vert(CT) -0.18 8-10 >999 240		
BCLL 0.0 *	Rep Stress Incr YES	Matrix-MS	Horz(CT) 0.02 6 n/a n/a		
BCDL 10.0	Code IRC2015/TPI2014			Weight: 119 lb	FT = 20%

LUMBER-
 TOP CHORD 2x4 SP No.2
 BOT CHORD 2x4 SP No.2
 WEBS 2x4 SP No.3
 WEDGE
 Left: 2x4 SP No.3 , Right: 2x4 SP No.3

BRACING-
 TOP CHORD Structural wood sheathing directly applied or 4-9-4 oc purlins.
 BOT CHORD Rigid ceiling directly applied or 10-0-0 oc bracing.
 MiTek recommends that Stabilizers and required cross bracing be installed during truss erection, in accordance with Stabilizer Installation guide.

REACTIONS. (lb/size) 2=971/0-3-8 (min. 0-1-8), 6=971/0-3-8 (min. 0-1-8)
 Max Horz 2=-237(LC 14)
 Max Uplift 2=-99(LC 16), 6=-99(LC 17)
 Max Grav 2=1130(LC 2), 6=1130(LC 2)

FORCES. (lb) - Max. Comp./Max. Ten. - All forces 250 (lb) or less except when shown.
 TOP CHORD 2-3=-1310/201, 3-17=-1176/291, 4-17=-1031/312, 4-18=-1031/312, 5-18=-1176/291, 5-6=-1310/201
 BOT CHORD 2-10=-128/1012, 10-19=0/665, 9-19=0/665, 9-20=0/665, 8-20=0/665, 6-8=-36/919
 WEBS 4-8=-167/590, 5-8=-366/249, 4-10=-167/590, 3-10=-366/249

- NOTES-**
- Unbalanced roof live loads have been considered for this design.
 - Wind: ASCE 7-10; Vult=130mph (3-second gust) Vasd=103mph; TCCL=6.0psf; BCDL=6.0psf; h=25ft; Cat. II; Exp B; Enclosed; MWFRS (envelope) gable end zone and C-C Exterior(2) zone; cantilever left and right exposed; end vertical left and right exposed; C-C for members and forces & MWFRS for reactions shown; Lumber DOL=1.60 plate grip DOL=1.60
 - TCCL: ASCE 7-10; Pr=30.0 psf (roof live load: Lumber DOL=1.15 Plate DOL=1.15); Pg=30.0 psf (ground snow); Pf=23.1 psf (flat roof snow: Lumber DOL=1.15 Plate DOL=1.15); Category II; Exp B; Partially Exp.; Ct=1.10
 - Unbalanced snow loads have been considered for this design.
 - This truss has been designed for greater of min roof live load of 12.0 psf or 1.00 times flat roof load of 23.1 psf on overhangs non-concurrent with other live loads.
 - This truss has been designed for a 10.0 psf bottom chord live load nonconcurrent with any other live loads.
 - * This truss has been designed for a live load of 20.0psf on the bottom chord in all areas where a rectangle 3-6-0 tall by 2-0-0 wide will fit between the bottom chord and any other members, with BCDL = 10.0psf.
 - Provide mechanical connection (by others) of truss to bearing plate capable of withstanding 100 lb uplift at joint(s) 2, 6.
 - This truss is designed in accordance with the 2015 International Residential Code sections R502.11.1 and R802.10.2 and referenced standard ANSI/TPI 1.

LOAD CASE(S) Standard

Job 20-6466-A	Truss PB04	Truss Type PIGGYBACK	Qty 2	Ply 3	GARY ROBINSON-LOT 73 SOUTH CREEK WOODLAKE MODEL ROOF
------------------	---------------	-------------------------	----------	----------	--

Riverside Roof Truss, LLC, Danville, VA. 24541

Run: 8.330 s Feb 24 2020 Print: 8.330 s Feb 24 2020 MiTek Industries, Inc. Wed Nov 11 16:39:07 2020 Page 1
ID:riFrQwqzJQyesEOjBg_H7VyKEle-EyGb5YMT4T0xP9yZaJ8zadQxNe8VyPPQv3r_ykCy2

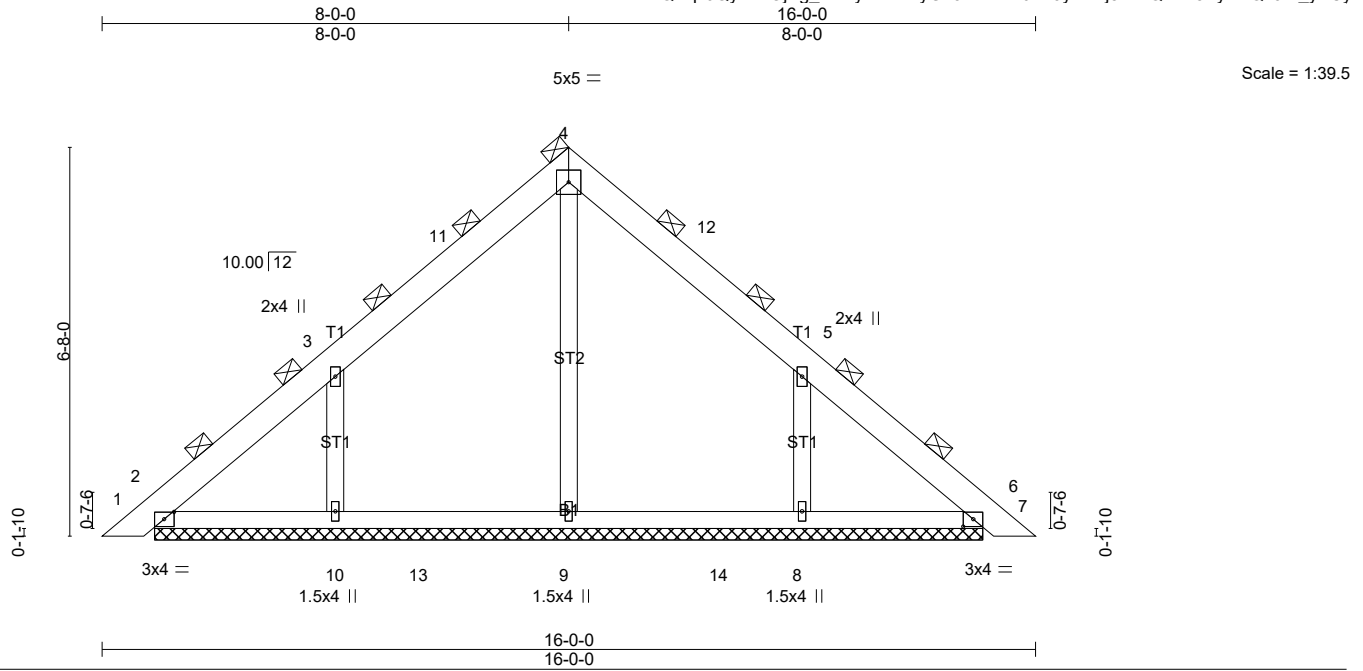

Plate Offsets (X,Y)-- [2:0-2-1,0-1-8], [6:0-2-1,0-1-8]

LOADING (psf)	SPACING-	CSI.	DEFL.	in (loc)	l/defl	L/d	PLATES	GRIP
TCLL (roof) 30.0	5-3-0	TC 0.11	Vert(LL)	0.00	6	n/r	MT20	244/190
Snow (Pf/Pg) 23.1/30.0	Plate Grip DOL 1.15	BC 0.16	Vert(CT)	0.00	6	n/r		
TCDL 10.0	Lumber DOL 1.15	WB 0.06	Horz(CT)	0.00	6	n/a		
BCLL 0.0 *	Rep Stress Incr NO	Matrix-S						
BCDL 10.0	Code IRC2015/TPI2014						Weight: 256 lb	FT = 20%

LUMBER-
 TOP CHORD 2x6 SP No.2
 BOT CHORD 2x4 SP No.2
 OTHERS 2x4 SP No.3

BRACING-
 TOP CHORD 2-0-0 oc purlins (6-0-0 max.)
 (Switched from sheeted: Spacing > 2-0-0).
 BOT CHORD Rigid ceiling directly applied or 10-0-0 oc bracing.

REACTIONS. All bearings 14-2-5.
 (lb) - Max Horz 2=-413(LC 14)
 Max Uplift All uplift 100 lb or less at joint(s) 2 except 10=-482(LC 16), 8=-476(LC 17)
 Max Grav All reactions 250 lb or less at joint(s) except 2=566(LC 2), 6=566(LC 2), 9=1004(LC 33), 10=1169(LC 30), 8=1162(LC 31)

FORCES. (lb) - Max. Comp./Max. Ten. - All forces 250 (lb) or less except when shown.
 TOP CHORD 2-3=-532/316, 3-11=-520/329, 4-11=-339/370, 4-12=-339/354, 5-12=-509/316, 5-6=-420/166
 BOT CHORD 2-10=-123/295, 10-13=-124/295, 9-13=-124/295, 9-14=-124/295, 8-14=-124/295, 6-8=-123/295
 WEBS 4-9=-493/0, 3-10=-903/594, 5-8=-896/588

- NOTES-**
- 3-ply truss to be connected together with 10d (0.131"x3") nails as follows:
 Top chords connected as follows: 2x6 - 2 rows staggered at 0-9-0 oc.
 Bottom chords connected as follows: 2x4 - 1 row at 0-9-0 oc.
 - All loads are considered equally applied to all plies, except if noted as front (F) or back (B) face in the LOAD CASE(S) section. Ply to ply connections have been provided to distribute only loads noted as (F) or (B), unless otherwise indicated.
 - Unbalanced roof live loads have been considered for this design.
 - Wind: ASCE 7-10; Vult=130mph (3-second gust) Vasd=103mph; TCCL=6.0psf; BCDL=6.0psf; h=25ft; Cat. II; Exp B; Enclosed; MWFRS (envelope) gable end zone and C-C Exterior(2) zone; cantilever left and right exposed; end vertical left and right exposed; C-C for members and forces & MWFRS for reactions shown; Lumber DOL=1.60 plate grip DOL=1.60
 - TCCL: ASCE 7-10; Pr=30.0 psf (roof live load: Lumber DOL=1.15 Plate DOL=1.15); Pg=30.0 psf (ground snow); Pf=23.1 psf (flat roof snow: Lumber DOL=1.15 Plate DOL=1.15); Category II; Exp B; Partially Exp.; Ct=1.10
 - Unbalanced snow loads have been considered for this design.
 - This truss has been designed for greater of min roof live load of 12.0 psf or 1.00 times flat roof load of 23.1 psf on overhangs non-concurrent with other live loads.
 - Gable requires continuous bottom chord bearing.
 - This truss has been designed for a 10.0 psf bottom chord live load nonconcurrent with any other live loads.
 - * This truss has been designed for a live load of 20.0psf on the bottom chord in all areas where a rectangle 3-6-0 tall by 2-0-0 wide will fit between the bottom chord and any other members, with BCDL = 10.0psf.
 - Provide mechanical connection (by others) of truss to bearing plate capable of withstanding 100 lb uplift at joint(s) 2 except (jt=lb) 10=482, 8=476.
 - This truss is designed in accordance with the 2015 International Residential Code sections R502.11.1 and R802.10.2 and referenced standard ANSI/TPI 1.
 - See Standard Industry Piggyback Truss Connection Detail for Connection to base truss as applicable, or consult qualified building designer.

Continued on page 2

Job	Truss	Truss Type	Qty	Ply	GARY ROBINSON-LOT 73 SOUTH CREEK WOODLAKE MODEL ROOF
20-6466-A	PB04	PIGGYBACK	2	3	Job Reference (optional)

Riverside Roof Truss, LLC, Danville, VA. 24541

Run: 8.330 s Feb 24 2020 Print: 8.330 s Feb 24 2020 MiTek Industries, Inc. Wed Nov 11 16:39:07 2020 Page 2
ID:riFrQwqzJQyesEOjBg_H7VyKEle-EyGb5YMT4T0xP9yZaNj8zadQxNe8VyPPQv3?r_ykCy2

LOAD CASE(S) Standard

Job	Truss	Truss Type	Qty	Ply	GARY ROBINSON-LOT 73 SOUTH CREEK WOODLAKE MODEL ROOF
20-6466-A	PB03	PIGGYBACK	2	2	Job Reference (optional)

Riverside Roof Truss, LLC, Danville, VA. 24541

Run: 8.330 s Feb 24 2020 Print: 8.330 s Feb 24 2020 MiTek Industries, Inc. Wed Nov 11 16:39:07 2020 Page 1
ID:riFrQwqzJQyesEOjBg_H7VyKEle-EyGb5YMT4T0xP9yZaNj8zadQLNfkVycPQv3?r_ykCy2

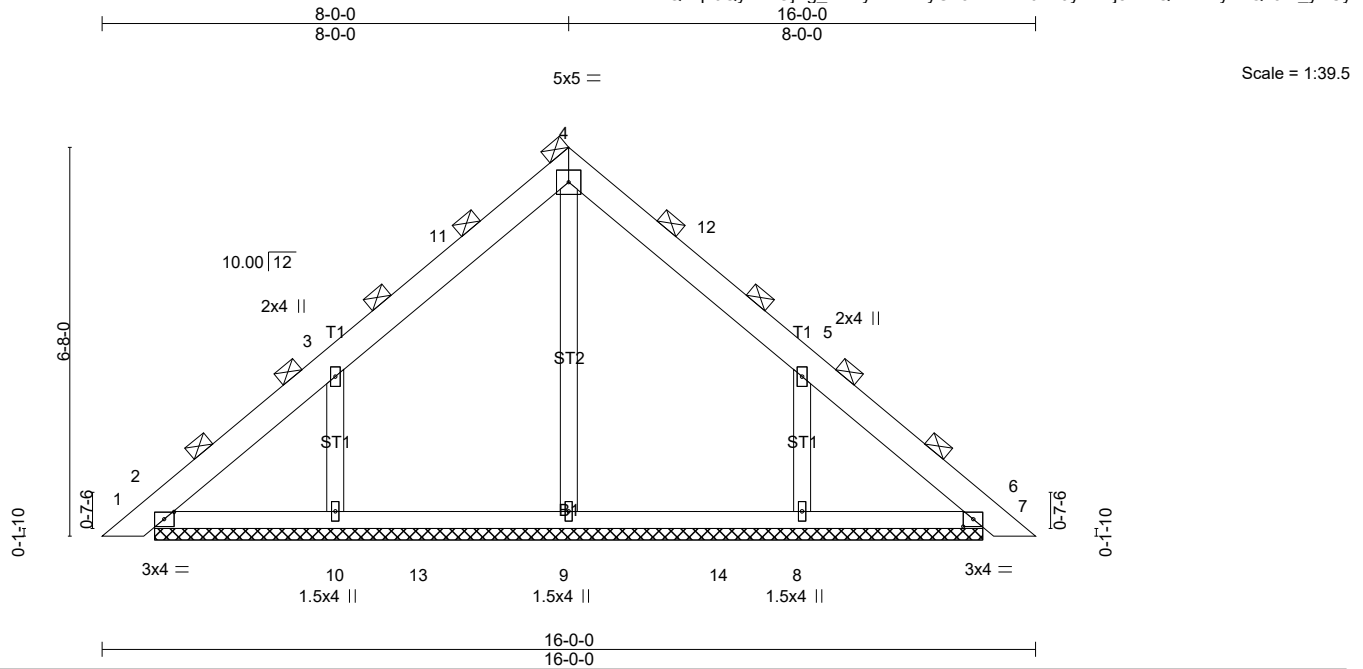

Plate Offsets (X,Y)-- [2:0-2-1,0-1-8], [6:0-2-1,0-1-8]

LOADING (psf)	SPACING-	CSI.	DEFL.	in (loc)	l/defl	L/d	PLATES	GRIP
TCLL (roof) 30.0	2-8-0	TC 0.08	Vert(LL)	0.00	6	n/r	MT20	244/190
Snow (Pf/Pg) 23.1/30.0	Plate Grip DOL 1.15	BC 0.12	Vert(CT)	0.00	6	n/r		
TCDL 10.0	Lumber DOL 1.15	WB 0.05	Horz(CT)	0.00	6	n/a		
BCLL 0.0 *	Rep Stress Incr NO	Matrix-S						
BCDL 10.0	Code IRC2015/TPI2014						Weight: 171 lb	FT = 20%

LUMBER-
 TOP CHORD 2x6 SP No.2
 BOT CHORD 2x4 SP No.2
 OTHERS 2x4 SP No.3

BRACING-
 TOP CHORD 2-0-0 oc purlins (6-0-0 max.)
 (Switched from sheeted: Spacing > 2-0-0).
 BOT CHORD Rigid ceiling directly applied or 10-0-0 oc bracing.

REACTIONS. All bearings 14-2-5.
 (lb) - Max Horz 2=210(LC 15)
 Max Uplift All uplift 100 lb or less at joint(s) 2 except 10=-245(LC 16), 8=-242(LC 17)
 Max Grav All reactions 250 lb or less at joint(s) except 2=288(LC 2), 6=288(LC 2), 9=510(LC 33), 10=594(LC 30),
 8=590(LC 31)

FORCES. (lb) - Max. Comp./Max. Ten. - All forces 250 (lb) or less except when shown.
 TOP CHORD 2-3=-270/160, 3-11=-264/167, 5-12=-259/162
 WEBS 4-9=-251/0, 3-10=-459/302, 5-8=-455/299

- NOTES-**
- 2-ply truss to be connected together with 10d (0.131"x3") nails as follows:
 Top chords connected as follows: 2x6 - 2 rows staggered at 0-9-0 oc.
 Bottom chords connected as follows: 2x4 - 1 row at 0-9-0 oc.
 - All loads are considered equally applied to all plies, except if noted as front (F) or back (B) face in the LOAD CASE(S) section. Ply to ply connections have been provided to distribute only loads noted as (F) or (B), unless otherwise indicated.
 - Unbalanced roof live loads have been considered for this design.
 - Wind: ASCE 7-10; Vult=130mph (3-second gust) Vasd=103mph; TCCL=6.0psf; BCDL=6.0psf; h=25ft; Cat. II; Exp B; Enclosed; MWFRS (envelope) gable end zone and C-C Exterior(2) zone; cantilever left and right exposed; end vertical left and right exposed; C-C for members and forces & MWFRS for reactions shown; Lumber DOL=1.60 plate grip DOL=1.60
 - TCCL: ASCE 7-10; Pr=30.0 psf (roof live load: Lumber DOL=1.15 Plate DOL=1.15); Pg=30.0 psf (ground snow); Pf=23.1 psf (flat roof snow: Lumber DOL=1.15 Plate DOL=1.15); Category II; Exp B; Partially Exp.; Ct=1.10
 - Unbalanced snow loads have been considered for this design.
 - This truss has been designed for greater of min roof live load of 12.0 psf or 1.00 times flat roof load of 23.1 psf on overhangs non-concurrent with other live loads.
 - Gable requires continuous bottom chord bearing.
 - This truss has been designed for a 10.0 psf bottom chord live load nonconcurrent with any other live loads.
 - * This truss has been designed for a live load of 20.0psf on the bottom chord in all areas where a rectangle 3-6-0 tall by 2-0-0 wide will fit between the bottom chord and any other members, with BCDL = 10.0psf.
 - Provide mechanical connection (by others) of truss to bearing plate capable of withstanding 100 lb uplift at joint(s) 2 except (jt=lb) 10=245, 8=242.
 - This truss is designed in accordance with the 2015 International Residential Code sections R502.11.1 and R802.10.2 and referenced standard ANSI/TPI 1.
 - See Standard Industry Piggyback Truss Connection Detail for Connection to base truss as applicable, or consult qualified building designer.
 - Graphical purlin representation does not depict the size or the orientation of the purlin along the top and/or bottom chord.

LOAD CASE(S) Standard

Job	Truss	Truss Type	Qty	Ply	GARY ROBINSON-LOT 73 SOUTH CREEK WOODLAKE MODEL ROOF
20-6466-A	PB02	Piggyback	13	1	Job Reference (optional)

Riverside Roof Truss, LLC, Danville, VA. 24541

Run: 8.330 s Feb 24 2020 Print: 8.330 s Feb 24 2020 MiTek Industries, Inc. Wed Nov 11 16:39:08 2020 Page 1
ID:riFrQwqzJQyesEOjBg_H7VyKEle-i9qzJuN5rm8o1JXl75ENVo9ZOn_BENAZfZpYNRyKCy1

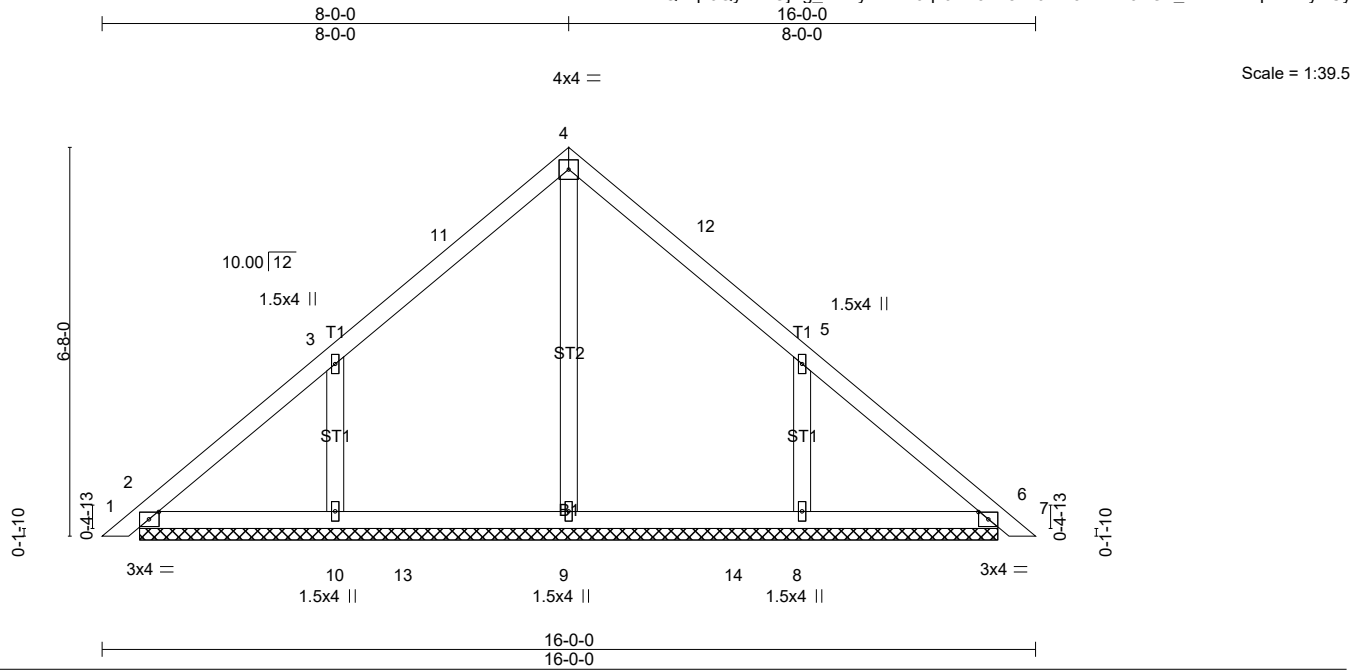

Plate Offsets (X,Y)-- [2:0-2-1,0-1-8], [6:0-2-1,0-1-8]

LOADING (psf)	SPACING-	CSI.	DEFL.	in (loc)	l/defl	L/d	PLATES	GRIP
TCLL (roof) 30.0	2-0-0	TC 0.25	Vert(LL)	0.00	7	n/r	MT20	244/190
Snow (Pf/Pg) 23.1/30.0	Plate Grip DOL 1.15	BC 0.17	Vert(CT)	0.00	7	n/r		
TCDL 10.0	Lumber DOL 1.15	WB 0.15	Horz(CT)	0.00	6	n/a		
BCLL 0.0 *	Rep Stress Incr YES	Matrix-S						
BCDL 10.0	Code IRC2015/TPI2014						Weight: 69 lb	FT = 20%

LUMBER-
 TOP CHORD 2x4 SP No.2
 BOT CHORD 2x4 SP No.2
 OTHERS 2x4 SP No.3

BRACING-
 TOP CHORD Structural wood sheathing directly applied or 6'-0-0 oc purlins.
 BOT CHORD Rigid ceiling directly applied or 10'-0-0 oc bracing.

MiTek recommends that Stabilizers and required cross bracing be installed during truss erection, in accordance with Stabilizer Installation guide.

REACTIONS. All bearings 14-8-9.
 (lb) - Max Horz 2=160(LC 15)
 Max Uplift All uplift 100 lb or less at joint(s) 2 except 10=-188(LC 16), 8=-188(LC 17)
 Max Grav All reactions 250 lb or less at joint(s) 2, 6 except 9=395(LC 33), 10=470(LC 30), 8=469(LC 31)

FORCES. (lb) - Max. Comp./Max. Ten. - All forces 250 (lb) or less except when shown.
 WEBS 3-10=-352/229, 5-8=-352/228

- NOTES-**
- 1) Unbalanced roof live loads have been considered for this design.
 - 2) Wind: ASCE 7-10; Vult=130mph (3-second gust) Vasd=103mph; TCCL=6.0psf; BCDL=6.0psf; h=25ft; Cat. II; Exp B; Enclosed; MWFRS (envelope) gable end zone and C-C Exterior(2) zone; cantilever left and right exposed; end vertical left and right exposed; C-C for members and forces & MWFRS for reactions shown; Lumber DOL=1.60 plate grip DOL=1.60
 - 3) TCCL: ASCE 7-10; Pr=30.0 psf (roof live load); Lumber DOL=1.15 Plate DOL=1.15; Pg=30.0 psf (ground snow); Pf=23.1 psf (flat roof snow); Lumber DOL=1.15 Plate DOL=1.15; Category II; Exp B; Partially Exp.; Ct=1.10
 - 4) Unbalanced snow loads have been considered for this design.
 - 5) This truss has been designed for greater of min roof live load of 12.0 psf or 1.00 times flat roof load of 23.1 psf on overhangs non-concurrent with other live loads.
 - 6) Gable requires continuous bottom chord bearing.
 - 7) This truss has been designed for a 10.0 psf bottom chord live load nonconcurrent with any other live loads.
 - 8) * This truss has been designed for a live load of 20.0psf on the bottom chord in all areas where a rectangle 3-6-0 tall by 2-0-0 wide will fit between the bottom chord and any other members, with BCDL = 10.0psf.
 - 9) Provide mechanical connection (by others) of truss to bearing plate capable of withstanding 100 lb uplift at joint(s) 2 except (jt=lb) 10=188, 8=188.
 - 10) This truss is designed in accordance with the 2015 International Residential Code sections R502.11.1 and R802.10.2 and referenced standard ANSI/TPI 1.
 - 11) See Standard Industry Piggyback Truss Connection Detail for Connection to base truss as applicable, or consult qualified building designer.

LOAD CASE(S) Standard

Job	Truss	Truss Type	Qty	Ply	GARY ROBINSON-LOT 73 SOUTH CREEK WOODLAKE MODEL ROOF
20-6466-A	PB01	GABLE	2	1	Job Reference (optional)

Riverside Roof Truss, LLC, Danville, VA. 24541

Run: 8.330 s Feb 24 2020 Print: 8.330 s Feb 24 2020 MiTek Industries, Inc. Wed Nov 11 16:39:08 2020 Page 1
ID:riFrQwqzJQyesEOjBg_H7VvYkEle-i9qzJuN5rm8o1JXl75ENVo9cQn0PEO0ZfzPYNRYkCy1

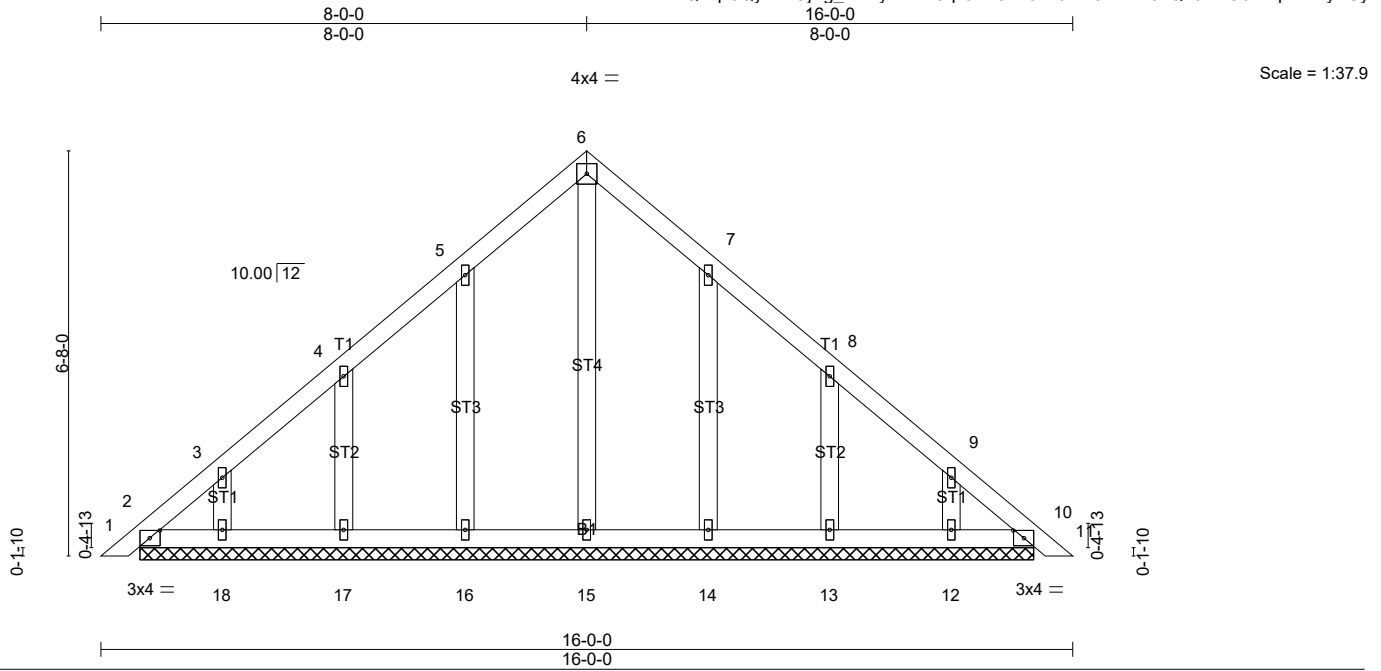

Plate Offsets (X,Y)-- [2:0-2-1,0-1-8], [10:0-2-1,0-1-8]

LOADING (psf)	SPACING-	CSI.	DEFL.	in (oc)	l/defl	L/d	PLATES	GRIP
TCLL (roof) 30.0	2-0-0	TC 0.06	Vert(LL)	0.00	10	n/r	MT20	244/190
Snow (Pf/Pg) 23.1/30.0	Plate Grip DOL 1.15	BC 0.03	Vert(CT)	0.00	10	n/r		
TCDL 10.0	Lumber DOL 1.15	WB 0.10	Horz(CT)	0.00	10	n/a		
BCLL 0.0 *	Rep Stress Incr YES	Matrix-S					Weight: 85 lb	FT = 20%
BCDL 10.0	Code IRC2015/TPI2014							

LUMBER-
 TOP CHORD 2x4 SP No.2
 BOT CHORD 2x4 SP No.2
 OTHERS 2x4 SP No.3

BRACING-
 TOP CHORD Structural wood sheathing directly applied or 6-0-0 oc purlins.
 BOT CHORD Rigid ceiling directly applied or 10-0-0 oc bracing.

MiTek recommends that Stabilizers and required cross bracing be installed during truss erection, in accordance with Stabilizer Installation guide.

REACTIONS. All bearings 14-8-9.
 (lb) - Max Horz 2=-160(LC 14)
 Max Uplift All uplift 100 lb or less at joint(s) 2, 10, 16, 17, 18, 14, 13, 12
 Max Grav All reactions 250 lb or less at joint(s) 2, 10, 15, 16, 17, 18, 14, 13, 12

FORCES. (lb) - Max. Comp./Max. Ten. - All forces 250 (lb) or less except when shown.

- NOTES-**
- Unbalanced roof live loads have been considered for this design.
 - Wind: ASCE 7-10; Vult=130mph (3-second gust) Vasd=103mph; TCCL=6.0psf; BCDL=6.0psf; h=25ft; Cat. II; Exp B; Enclosed; MWFRS (envelope) gable end zone and C-C Exterior(2) zone; cantilever left and right exposed; end vertical left and right exposed; C-C for members and forces & MWFRS for reactions shown; Lumber DOL=1.60 plate grip DOL=1.60
 - Truss designed for wind loads in the plane of the truss only. For studs exposed to wind (normal to the face), see Standard Industry Gable End Details as applicable, or consult qualified building designer as per ANSI/TPI 1.
 - TCCL: ASCE 7-10; Pr=30.0 psf (roof live load: Lumber DOL=1.15 Plate DOL=1.15); Pg=30.0 psf (ground snow); Pf=23.1 psf (flat roof snow: Lumber DOL=1.15 Plate DOL=1.15); Category II; Exp B; Partially Exp.; Ct=1.10
 - Unbalanced snow loads have been considered for this design.
 - This truss has been designed for greater of min roof live load of 12.0 psf or 1.00 times flat roof load of 23.1 psf on overhangs non-concurrent with other live loads.
 - All plates are 1.5x4 MT20 unless otherwise indicated.
 - Gable requires continuous bottom chord bearing.
 - Gable studs spaced at 2-0-0 oc.
 - This truss has been designed for a 10.0 psf bottom chord live load nonconcurrent with any other live loads.
 - * This truss has been designed for a live load of 20.0psf on the bottom chord in all areas where a rectangle 3-6-0 tall by 2-0-0 wide will fit between the bottom chord and any other members.
 - Provide mechanical connection (by others) of truss to bearing plate capable of withstanding 100 lb uplift at joint(s) 2, 10, 16, 17, 18, 14, 13, 12.
 - This truss is designed in accordance with the 2015 International Residential Code sections R502.11.1 and R802.10.2 and referenced standard ANSI/TPI 1.
 - See Standard Industry Piggyback Truss Connection Detail for Connection to base truss as applicable, or consult qualified building designer.

LOAD CASE(S) Standard

Job 20-6466-A	Truss G01	Truss Type Common Girder	Qty 1	Ply 3	GARY ROBINSON-LOT 73 SOUTH CREEK WOODLAKE MODEL ROOF Job Reference (optional)
------------------	--------------	-----------------------------	----------	----------	--

Riverside Roof Truss, LLC, Danville, VA. 24541

Run: 8.330 s Feb 24 2020 Print: 8.330 s Feb 24 2020 MiTek Industries, Inc. Wed Nov 11 16:39:10 2020 Page 1
ID:riFrQwqzJQyesEOjBg_H7VyKEle-eXykkaPLNOPWGcg8FWGrDFmEba4i6As6tlfSjyKCy?

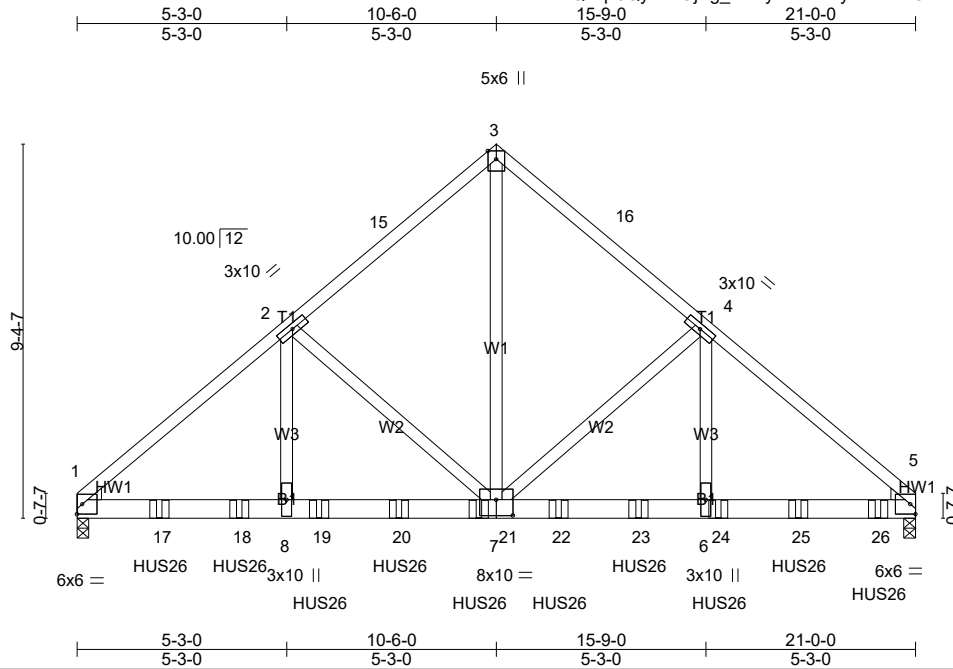

Plate Offsets (X,Y)-- [7:0-5-0,0-4-12]

LOADING (psf)	SPACING-	CSI.	DEFL.	PLATES	GRIP
TCLL (roof) 30.0	2-0-0	TC 0.81	in (loc) l/defl L/d	MT20	244/190
Snow (Pf/Pg) 23.1/30.0	Plate Grip DOL 1.15	BC 0.53	Vert(LL) -0.13 7-8 >999 360		
TCDL 10.0	Lumber DOL 1.15	WB 0.89	Vert(CT) -0.23 7-8 >999 240		
BCLL 0.0 *	Rep Stress Incr NO	Matrix-MS	Horz(CT) 0.04 5 n/a n/a		
BCDL 10.0	Code IRC2015/TPI2014			Weight: 409 lb	FT = 20%

LUMBER-
 TOP CHORD 2x4 SP No.2
 BOT CHORD 2x6 SP 2400F 2.0E
 WEBS 2x4 SP No.3 *Except*
 W1: 2x4 SP No.2
 WEDGE
 Left: 2x4 SP No.3 , Right: 2x4 SP No.3

BRACING-
 TOP CHORD Structural wood sheathing directly applied or 5-6-4 oc purlins.
 BOT CHORD Rigid ceiling directly applied or 10-0-0 oc bracing.

REACTIONS. (lb/size) 1=10048/0-3-8 (min. 0-2-12), 5=11084/0-3-8 (min. 0-3-1)
 Max Horz 1=-216(LC 12)
 Max Uplift 1=-394(LC 16), 5=-430(LC 17)
 Max Grav 1=10073(LC 2), 5=11096(LC 2)

FORCES. (lb) - Max. Comp./Max. Ten. - All forces 250 (lb) or less except when shown.
 TOP CHORD 1-2=-12955/608, 2-15=-8918/499, 3-15=-8779/519, 3-16=-8781/519, 4-16=-8920/499,
 4-5=-13060/611
 BOT CHORD 1-17=-452/9850, 17-18=-452/9850, 8-18=-452/9850, 8-19=-452/9850, 19-20=-452/9850,
 20-21=-452/9850, 7-21=-452/9850, 7-22=-376/9938, 22-23=-376/9938, 6-23=-376/9938,
 6-24=-376/9938, 24-25=-376/9938, 25-26=-376/9938, 5-26=-376/9938
 WEBS 3-7=-524/10873, 4-7=-4244/341, 4-6=-134/5087, 2-7=-4128/336, 2-8=-129/4954

- NOTES-**
- 3-ply truss to be connected together with 10d (0.131"x3") nails as follows:
 Top chords connected as follows: 2x4 - 1 row at 0-9-0 oc.
 Bottom chords connected as follows: 2x6 - 3 rows staggered at 0-5-0 oc.
 Webs connected as follows: 2x4 - 1 row at 0-9-0 oc.
 - All loads are considered equally applied to all plies, except if noted as front (F) or back (B) face in the LOAD CASE(S) section. Ply to ply connections have been provided to distribute only loads noted as (F) or (B), unless otherwise indicated.
 - Unbalanced roof live loads have been considered for this design.
 - Wind: ASCE 7-10; Vult=130mph (3-second gust) Vasd=103mph; TCCL=6.0psf; BCDL=6.0psf; h=25ft; Cat. II; Exp B; Enclosed; MWFRS (envelope) gable end zone and C-C Exterior(2) zone; cantilever left and right exposed ; end vertical left and right exposed;C-C for members and forces & MWFRS for reactions shown; Lumber DOL=1.60 plate grip DOL=1.60
 - TCCL: ASCE 7-10; Pr=30.0 psf (roof live load: Lumber DOL=1.15 Plate DOL=1.15); Pg=30.0 psf (ground snow); Pf=23.1 psf (flat roof snow: Lumber DOL=1.15 Plate DOL=1.15); Category II; Exp B; Partially Exp.; Ct=1.10
 - Unbalanced snow loads have been considered for this design.
 - This truss has been designed for a 10.0 psf bottom chord live load nonconcurrent with any other live loads.
 - * This truss has been designed for a live load of 20.0psf on the bottom chord in all areas where a rectangle 3-6-0 tall by 2-0-0 wide will fit between the bottom chord and any other members.
 - Provide mechanical connection (by others) of truss to bearing plate capable of withstanding 100 lb uplift at joint(s) except (jt=lb) 1=394, 5=430.
 - This truss is designed in accordance with the 2015 International Residential Code sections R502.11.1 and R802.10.2 and referenced standard ANSI/TPI 1.

Job 20-6466-A	Truss G01	Truss Type Common Girder	Qty 1	Ply 3	GARY ROBINSON-LOT 73 SOUTH CREEK WOODLAKE MODEL ROOF Job Reference (optional)
------------------	--------------	-----------------------------	----------	----------	--

Riverside Roof Truss, LLC, Danville, VA. 24541

Run: 8.330 s Feb 24 2020 Print: 8.330 s Feb 24 2020 MiTek Industries, Inc. Wed Nov 11 16:39:10 2020 Page 2
ID:riFrQwqzJQyesEOjBg_H7VyKEle-eXykkaPLNOPWGcg8FWGraDFmEba4i6As6tlfSjyKCy?

NOTES-

- 11) Use Simpson Strong-Tie HUS26 (14-10d Girder, 6-10d Truss, Single Ply Girder) or equivalent spaced at 2-0-0 oc max. starting at 2-0-12 from the left end to 20-0-12 to connect truss(es) AT01 (1 ply 2x10 SP) to back face of bottom chord.
- 12) Fill all nail holes where hanger is in contact with lumber.

LOAD CASE(S) Standard

1) Dead + Snow (balanced): Lumber Increase=1.15, Plate Increase=1.15

Uniform Loads (plf)

Vert: 1-3=-66, 3-5=-66, 9-12=-20

Concentrated Loads (lb)

Vert: 17=-1932(B) 18=-1932(B) 19=-1932(B) 20=-1932(B) 21=-1932(B) 22=-1932(B) 23=-1932(B) 24=-1932(B) 25=-1932(B) 26=-1933(B)

Job	Truss	Truss Type	Qty	Ply	GARY ROBINSON-LOT 73 SOUTH CREEK WOODLAKE MODEL ROOF
20-6466-A	ATGE02	GABLE	1	1	Job Reference (optional)

Riverside Roof Truss, LLC, Danville, VA. 24541

Run: 8.330 s Feb 24 2020 Print: 8.330 s Feb 24 2020 MiTek Industries, Inc. Wed Nov 11 16:39:12 2020 Page 1
 ID:riFrQwqzJQyesEOjBg_H7VyKEle-aw4U9GQcv?fEVWqWMxIJgeK8cO9PA?V9ZBnmVCyKCxZ

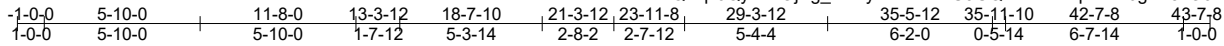

Scale = 1:86.2

Plate Offsets (X,Y)-- [2:0-4-0,0-1-3], [4:0-2-5,0-0-0], [4:0-0-0,0-2-12], [6:0-3-12,0-3-8], [8:0-9-8,0-3-4], [10:0-3-10,Edge], [19:0-3-8,0-7-0], [19:0-0-8,0-2-0], [21:0-2-12,0-2-8], [22:0-2-4,0-1-8], [24:0-3-4,0-2-8], [27:0-1-8,0-0-12], [31:0-1-10,0-0-12], [32:0-1-8,0-0-12], [39:0-1-10,0-0-12]

LOADING (psf)	SPACING-	CSI.	DEFL.	PLATES	GRIP
TCLL (roof) 30.0	2-0-0	TC 0.69	in (loc) l/defl L/d	MT20	244/190
Snow (Pf/Pg) 23.1/30.0	Plate Grip DOL 1.15	BC 0.92	Vert(LL) -0.27 17-19 >999 360		
TCDL 10.0	Lumber DOL 1.15	WB 0.90	Vert(CT) -0.42 17-19 >999 240		
BCLL 0.0 *	Rep Stress Incr YES	Matrix-MS	Horz(CT) 0.05 12 n/a n/a		
BCDL 10.0	Code IRC2015/TPI2014		Attic -0.15 17-19 969 360	Weight: 551 lb	FT = 20%

LUMBER-	BRACING-
TOP CHORD 2x6 SP No.2 *Except* T2: 2x6 SP 2400F 2.0E	TOP CHORD Structural wood sheathing directly applied or 3-8-13 oc purlins, except 2-0-0 oc purlins (3-5-6 max.): 6-8.
BOT CHORD 2x10 SP No.2	BOT CHORD Rigid ceiling directly applied or 2-2-0 oc bracing.
WEBS 2x4 SP No.3 *Except* W9: 2x4 SP DSS, W5,W4,W1: 2x4 SP No.2	WEBS 1 Row at midpt 23-24, 15-20, 6-24 2 Rows at 1/3 pts 14-21 1 Brace at Jt(s): 20, 21, 23, 24
OTHERS 2x4 SP No.3	JOINTS

MiTek recommends that Stabilizers and required cross bracing be installed during truss erection, in accordance with Stabilizer Installation guide.

REACTIONS. (lb/size) 2=1873/0-3-8 (min. 0-2-10), 14=1796/0-3-8 (min. 0-3-0), 12=637/0-3-8 (min. 0-1-8)
 Max Horz 2=-297(LC 14)
 Max Uplift 12=-121(LC 16)
 Max Grav 2=2243(LC 46), 14=2540(LC 58), 12=787(LC 40)

FORCES. (lb) - Max. Comp./Max. Ten. - All forces 250 (lb) or less except when shown.
 TOP CHORD 2-68=-3178/101, 3-68=-2987/123, 3-4=-2827/74, 4-5=-2681/116, 5-6=-1940/249,
 6-69=-2697/388, 7-69=-2697/388, 7-70=-2697/388, 8-70=-2697/388, 8-9=-741/99,
 9-10=-917/290, 10-11=-931/265, 11-71=-649/265, 71-72=-717/253, 12-72=-883/229
 BOT CHORD 2-19=-90/2550, 18-19=-6/2120, 17-18=-6/2120, 17-73=-6/2120, 16-73=-6/2120,
 15-16=-6/2120, 15-74=-74/1458, 14-74=-74/1458, 12-14=-174/551
 WEBS 3-19=-805/274, 19-25=0/1209, 5-25=0/1075, 17-20=0/1020, 15-21=0/954, 23-25=-389/0,
 23-24=-376/0, 22-24=-1450/104, 20-22=-1450/104, 20-21=-859/181, 9-21=-236/518,
 15-20=-1335/0, 11-14=-876/258, 14-21=-1978/0, 8-21=-829/236, 7-24=-1051/263,
 6-24=-580/1053, 8-24=-300/2172

- NOTES-**
- Unbalanced roof live loads have been considered for this design.
 - Wind: ASCE 7-10; Vult=130mph (3-second gust) Vasd=103mph; TC DL=6.0psf; BCDL=6.0psf; h=25ft; Cat. II; Exp B; Enclosed; MWFRS (envelope) gable end zone and C-C Exterior(2) zone; cantilever left and right exposed ; end vertical left and right exposed;C-C for members and forces & MWFRS for reactions shown; Lumber DOL=1.60 plate grip DOL=1.60
 - Truss designed for wind loads in the plane of the truss only. For studs exposed to wind (normal to the face), see Standard Industry Gable End Details as applicable, or consult qualified building designer as per ANSI/TPI 1.
 - TCLL: ASCE 7-10; Pr=30.0 psf (roof live load: Lumber DOL=1.15 Plate DOL=1.15); Pg=30.0 psf (ground snow); Pf=23.1 psf (flat roof snow: Lumber DOL=1.15 Plate DOL=1.15); Category II; Exp B; Partially Exp.; Ct=1.10, Lu=50-0-0
 - Unbalanced snow loads have been considered for this design.
 - This truss has been designed for greater of min roof live load of 12.0 psf or 1.00 times flat roof load of 23.1 psf on overhangs non-concurrent with other live loads.
 - Provide adequate drainage to prevent water ponding.
 - All plates are 1.5x4 MT20 unless otherwise indicated.
 - Gable studs spaced at 2-0-0 oc.
 - This truss has been designed for a 10.0 psf bottom chord live load nonconcurrent with any other live loads.

Continued on page 2

Job	Truss	Truss Type	Qty	Ply	GARY ROBINSON-LOT 73 SOUTH CREEK WOODLAKE MODEL ROOF
20-6466-A	ATGE02	GABLE	1	1	Job Reference (optional)

Riverside Roof Truss, LLC, Danville, VA. 24541

Run: 8.330 s Feb 24 2020 Print: 8.330 s Feb 24 2020 MiTek Industries, Inc. Wed Nov 11 16:39:12 2020 Page 2
 ID:riFrQwqzJQyesEOjBg_H7VyKEle-aw4U9GQcv?fEVwqWMxIJgeK8cO9PA?V9ZBnmVCyKCxz

NOTES-

- 11) * This truss has been designed for a live load of 20.0psf on the bottom chord in all areas where a rectangle 3-6-0 tall by 2-0-0 wide will fit between the bottom chord and any other members, with BCDL = 10.0psf.
- 12) Ceiling dead load (5.0 psf) on member(s). 23-25, 23-24, 20-24, 20-21, 9-21; Wall dead load (5.0psf) on member(s).19-25, 17-20
- 13) Bottom chord live load (40.0 psf) and additional bottom chord dead load (5.0 psf) applied only to room. 17-19
- 14) Provide mechanical connection (by others) of truss to bearing plate capable of withstanding 100 lb uplift at joint(s) except (jt=lb) 12=121.
- 15) This truss is designed in accordance with the 2015 International Residential Code sections R502.11.1 and R802.10.2 and referenced standard ANSI/TPI 1.
- 16) Graphical purlin representation does not depict the size or the orientation of the purlin along the top and/or bottom chord.
- 17) Attic room checked for L/360 deflection.

LOAD CASE(S) Standard

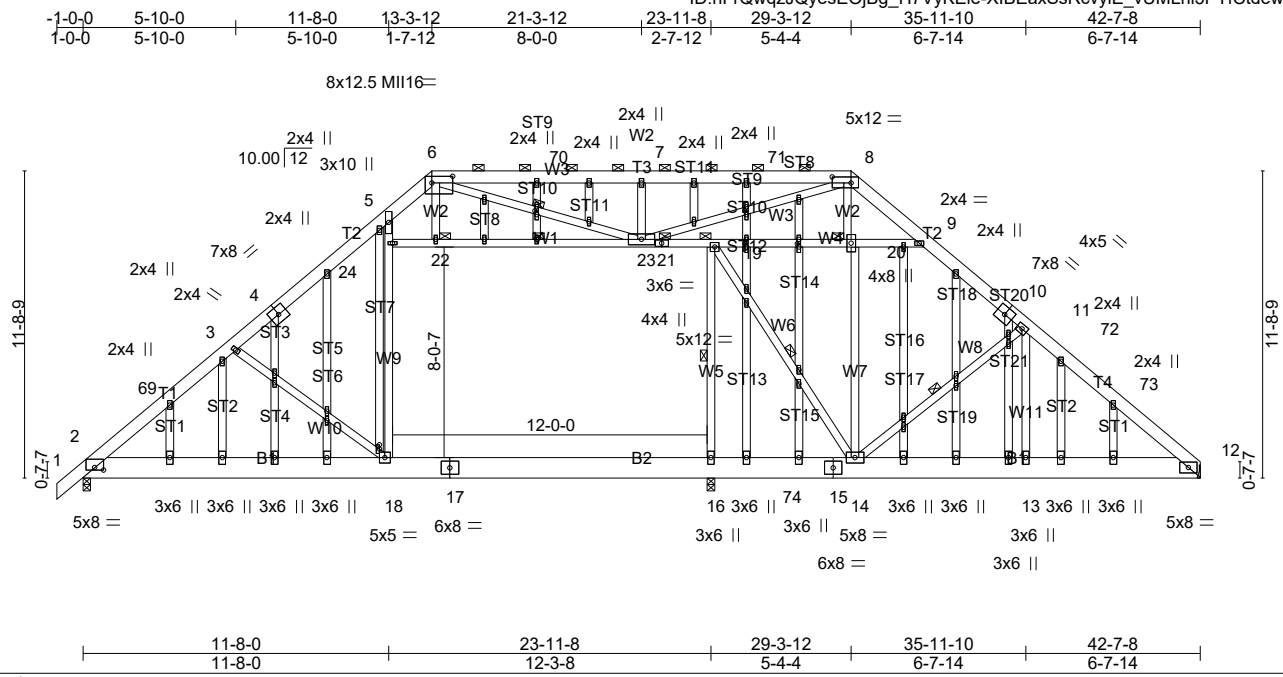

Plate Offsets (X,Y)-- [2:0-4-0,0-1-3], [4:0-2-5,0-0-0], [4:0-0-0,0-2-12], [6:0-9-8,0-3-0], [8:0-8-12,0-2-12], [10:0-2-5,0-0-0], [10:0-0-0,0-2-12], [18:0-2-0,0-0-0], [26:0-1-8,0-0-12], [30:0-1-10,0-0-12], [31:0-1-8,0-0-12], [38:0-1-10,0-0-12]

LOADING (psf)	SPACING-	CSI.	DEFL.		PLATES	GRIP
TCLL (roof) 30.0	2-0-0	TC 0.72	in (loc) l/defl L/d		MT20	244/190
Snow (Pf/Pg) 23.1/30.0	Plate Grip DOL 1.15	BC 0.81	Vert(LL) -0.26 16-18 >999 360		MII16	174/126
TCDL 10.0	Lumber DOL 1.15	WB 0.87	Vert(CT) -0.42 16-18 >691 240			
BCLL 0.0 *	Rep Stress Incr YES	Matrix-MS	Horz(CT) 0.05 12 n/a n/a			
BCDL 10.0	Code IRC2015/TPI2014		Attic -0.14 16-18 1061 360		Weight: 552 lb	FT = 20%

LUMBER-	BRACING-
TOP CHORD 2x6 SP No.2 *Except* T2: 2x6 SP 2400F 2.0E	TOP CHORD Structural wood sheathing directly applied or 3-10-7 oc purlins, except 2-0-0 oc purlins (3-2-2 max.): 6-8.
BOT CHORD 2x10 SP No.2 *Except* B2: 2x10 SP No.1	BOT CHORD Rigid ceiling directly applied or 9-10-2 oc bracing.
WEBS 2x4 SP No.3 *Except* W9,W5,W4,W1: 2x4 SP No.2	WEBS 1 Row at midpt 16-19, 11-14, 22-23, 14-19, 6-23
OTHERS 2x4 SP No.3	JOINTS 1 Brace at Jt(s): 19, 20, 22, 23

MiTek recommends that Stabilizers and required cross bracing be installed during truss erection, in accordance with Stabilizer Installation guide.

REACTIONS. (lb/size) 2=1868/0-3-8 (min. 0-2-9), 16=695/0-3-8 (min. 0-1-8), 12=1671/Mechanical
 Max Horz 2=290(LC 13)
 Max Uplift 2=-48(LC 16)
 Max Grav 2=2161(LC 40), 16=1200(LC 58), 12=1954(LC 40)

FORCES. (lb) - Max. Comp./Max. Ten. - All forces 250 (lb) or less except when shown.
 TOP CHORD 2-69=-2951/187, 3-69=-2753/208, 3-4=-2607/168, 4-5=-2452/202, 5-6=-2023/295,
 6-70=-2964/488, 7-70=-2964/488, 7-71=-2964/488, 8-71=-2964/488, 8-9=-1761/194,
 9-10=-2060/294, 10-11=-2156/268, 11-72=-2466/271, 72-73=-2587/249, 12-73=-2757/244
 BOT CHORD 2-18=-193/2395, 17-18=-119/1922, 16-17=-119/1922, 16-74=-119/1922, 15-74=-119/1922,
 14-15=-119/1922, 13-14=-79/1987, 12-13=-79/1987
 WEBS 3-18=-826/270, 18-24=0/1062, 5-24=0/921, 16-19=-400/408, 14-20=0/503, 11-14=-621/207,
 11-13=0/335, 21-23=-905/85, 19-21=-905/85, 19-20=-656/163, 9-20=-662/162,
 14-19=-797/210, 8-20=0/504, 7-23=-1068/262, 6-23=-527/1287, 8-23=-318/1731

- NOTES-**
- 1) Unbalanced roof live loads have been considered for this design.
 - 2) Wind: ASCE 7-10; Vult=130mph (3-second gust) Vasd=103mph; TC DL=6.0psf; BCDL=6.0psf; h=25ft; Cat. II; Exp B; Enclosed; MWFRS (envelope) gable end zone and C-C Exterior(2) zone; cantilever left and right exposed; end vertical left and right exposed; C-C for members and forces & MWFRS for reactions shown; Lumber DOL=1.60 plate grip DOL=1.60
 - 3) Truss designed for wind loads in the plane of the truss only. For studs exposed to wind (normal to the face), see Standard Industry Gable End Details as applicable, or consult qualified building designer as per ANSI/TPI 1.
 - 4) TCLL: ASCE 7-10; Pr=30.0 psf (roof live load: Lumber DOL=1.15 Plate DOL=1.15); Pg=30.0 psf (ground snow); Pf=23.1 psf (flat roof snow: Lumber DOL=1.15 Plate DOL=1.15); Category II; Exp B; Partially Exp.; Ct=1.10, Lu=50-0-0
 - 5) Unbalanced snow loads have been considered for this design.
 - 6) This truss has been designed for greater of min roof live load of 12.0 psf or 1.00 times flat roof load of 23.1 psf on overhangs non-concurrent with other live loads.
 - 7) Provide adequate drainage to prevent water ponding.
 - 8) All plates are MT20 plates unless otherwise indicated.
 - 9) All plates are 1.5x4 MT20 unless otherwise indicated.
 - 10) Gable studs spaced at 2-0-0 oc.
 - 11) This truss has been designed for a 10.0 psf bottom chord live load nonconcurrent with any other live loads.

Job	Truss	Truss Type	Qty	Ply	GARY ROBINSON-LOT 73 SOUTH CREEK WOODLAKE MODEL ROOF
20-6466-A	ATGE01	GABLE	1	1	Job Reference (optional)

Riverside Roof Truss, LLC, Danville, VA. 24541

Run: 8.330 s Feb 24 2020 Print: 8.330 s Feb 24 2020 MiTek Industries, Inc. Wed Nov 11 16:39:14 2020 Page 2
 ID:riFrQwqzJQyesEOjBg_H7VyKEle-XIBEaxSsRcvylE_vUMLnI3PTfCtdewUR1VGta4yKCxx

NOTES-

- 12) * This truss has been designed for a live load of 20.0psf on the bottom chord in all areas where a rectangle 3-6-0 tall by 2-0-0 wide will fit between the bottom chord and any other members, with BCDL = 10.0psf.
- 13) Ceiling dead load (5.0 psf) on member(s). 22-24, 22-23, 19-23, 19-20, 9-20; Wall dead load (5.0psf) on member(s).18-24, 16-19
- 14) Bottom chord live load (40.0 psf) and additional bottom chord dead load (5.0 psf) applied only to room. 16-18
- 15) Refer to girder(s) for truss to truss connections.
- 16) Provide mechanical connection (by others) of truss to bearing plate capable of withstanding 100 lb uplift at joint(s) 2.
- 17) This truss is designed in accordance with the 2015 International Residential Code sections R502.11.1 and R802.10.2 and referenced standard ANSI/TPI 1.
- 18) Graphical purlin representation does not depict the size or the orientation of the purlin along the top and/or bottom chord.
- 19) Attic room checked for L/360 deflection.

LOAD CASE(S) Standard

Job	Truss	Truss Type	Qty	Ply	GARY ROBINSON-LOT 73 SOUTH CREEK WOODLAKE MODEL ROOF
20-6466-A	AT02	Attic	3	1	Job Reference (optional)

Riverside Roof Truss, LLC, Danville, VA. 24541

Run: 8.330 s Feb 24 2020 Print: 8.330 s Feb 24 2020 MiTek Industries, Inc. Wed Nov 11 16:39:15 2020 Page 1
 ID:riFrQwqzJQyesEOjBg_H7VyKEle-?VldnHTUBw1pMNZ523s0HGyfs0B5NMfB9?Q6XyKCxw

-1-0-0	5-10-0	11-8-0	13-3-12	18-7-10	21-3-12	23-11-8	29-3-12	35-5-12	35-11-10	42-7-8	43-7-8
1-0-0	5-10-0	5-10-0	1-7-12	5-3-14	2-8-2	2-7-12	5-4-4	6-2-0	0-5-14	6-7-14	1-0-0

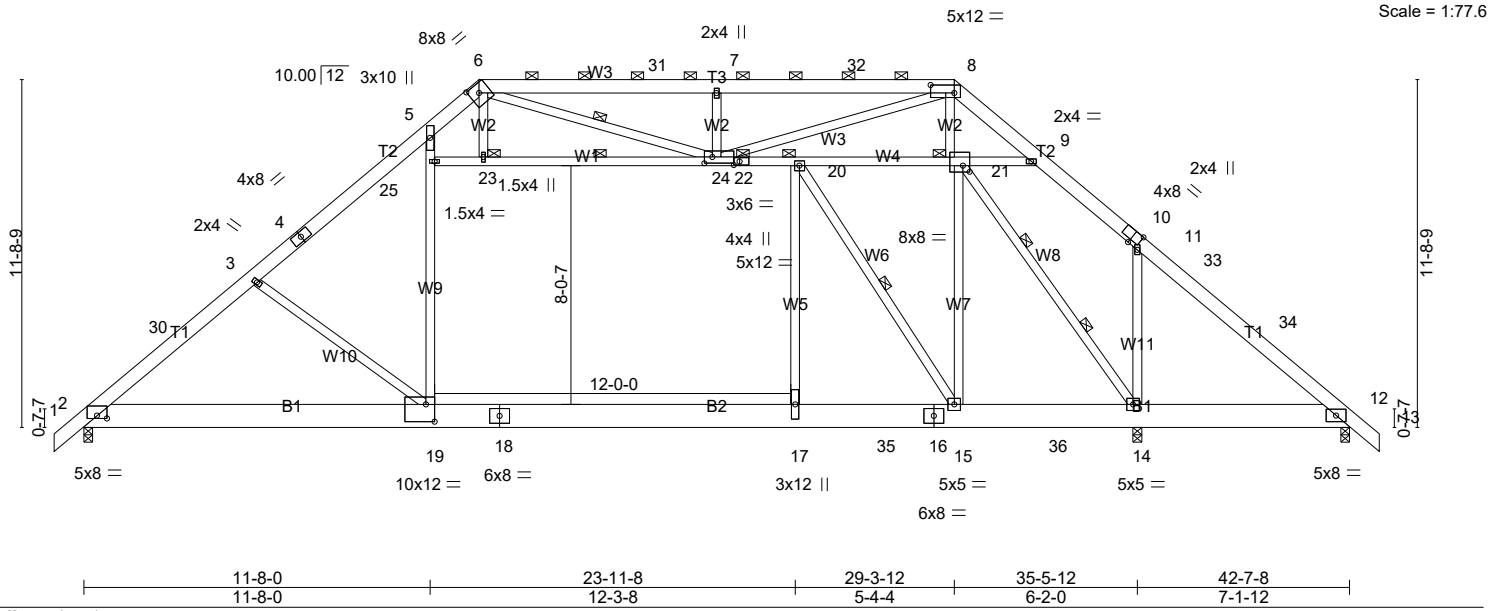

Plate Offsets (X,Y)--	[2:0-4-0,0-1-3], [6:0-3-12,0-3-8], [8:0-9-8,0-3-4], [10:0-3-10,Edge], [19:0-3-8,0-7-0], [21:0-2-12,0-2-8], [22:0-2-4,0-1-8], [24:0-3-4,0-2-8]
-----------------------	---

LOADING (psf)	SPACING-	CSI.	DEFL.	PLATES	GRIP
TCLL (roof) 30.0	2-0-0	TC 0.69	in (loc) l/defl L/d	MT20	244/190
Snow (Pf/Pg) 23.1/30.0	Plate Grip DOL 1.15	BC 0.92	Vert(LL) -0.27 17-19 >999 360		
TCDL 10.0	Lumber DOL 1.15	WB 0.90	Vert(CT) -0.42 17-19 >999 240		
BCLL 0.0 *	Rep Stress Incr YES	Matrix-MS	Horz(CT) 0.05 12 n/a n/a		
BCDL 10.0	Code IRC2015/TPI2014		Attic -0.15 17-19 969 360	Weight: 442 lb	FT = 20%

LUMBER-	BRACING-
TOP CHORD 2x6 SP No.2 *Except* T2: 2x6 SP 2400F 2.0E	TOP CHORD Structural wood sheathing directly applied or 3-8-13 oc purlins, except 2-0-0 oc purlins (3-5-6 max.): 6-8.
BOT CHORD 2x10 SP No.2	BOT CHORD Rigid ceiling directly applied or 2-2-0 oc bracing.
WEBS 2x4 SP No.3 *Except* W9: 2x4 SP DSS, W5,W4,W1: 2x4 SP No.2	WEBS 1 Row at midpt 23-24, 15-20, 6-24 2 Rows at 1/3 pts 14-21 1 Brace at Jt(s): 20, 21, 23, 24
	JOINTS 1 Brace at Jt(s): 20, 21, 23, 24

MiTek recommends that Stabilizers and required cross bracing be installed during truss erection, in accordance with Stabilizer Installation guide.

REACTIONS. (lb/size) 2=1873/0-3-8 (min. 0-2-10), 14=1796/0-3-8 (min. 0-3-0), 12=637/0-3-8 (min. 0-1-8)
 Max Horz 2=-297(LC 14)
 Max Uplift 2=-70(LC 16), 14=-87(LC 17), 12=-167(LC 16)
 Max Grav 2=2243(LC 46), 14=2540(LC 58), 12=787(LC 40)

FORCES. (lb) - Max. Comp./Max. Ten. - All forces 250 (lb) or less except when shown.
 TOP CHORD 2-30=-3178/101, 3-30=-2987/123, 3-4=-2827/74, 4-5=-2681/116, 5-6=-1940/249,
 6-31=-2697/388, 7-31=-2697/388, 7-32=-2697/388, 8-32=-2697/388, 8-9=-741/99,
 9-10=-917/298, 10-11=-931/273, 11-33=-649/267, 33-34=-717/255, 12-34=-883/240
 BOT CHORD 2-19=-108/2550, 18-19=-6/2086, 17-18=-6/2086, 17-35=-6/2086, 16-35=-6/2086,
 15-16=-6/2086, 15-36=-74/1421, 14-36=-74/1421, 12-14=-174/551
 WEBS 3-19=-805/270, 19-25=0/1209, 5-25=0/1075, 17-20=0/1020, 15-21=0/954, 23-25=-389/0,
 23-24=-376/0, 22-24=-1450/124, 20-22=-1450/124, 20-21=-859/181, 9-21=-236/548,
 15-20=-1335/0, 11-14=-876/277, 14-21=-1978/0, 8-21=-829/236, 7-24=-1051/263,
 6-24=-580/1053, 8-24=-300/2172

- NOTES-**
- Unbalanced roof live loads have been considered for this design.
 - Wind: ASCE 7-10; Vult=130mph (3-second gust) Vasd=103mph; TCCL=6.0psf; BCDL=6.0psf; h=25ft; Cat. II; Exp B; Enclosed; MWFRS (envelope) gable end zone and C-C Exterior(2) zone; cantilever left and right exposed ; end vertical left and right exposed;C-C for members and forces & MWFRS for reactions shown; Lumber DOL=1.60 plate grip DOL=1.60
 - TCCL: ASCE 7-10; Pr=30.0 psf (roof live load: Lumber DOL=1.15 Plate DOL=1.15); Pg=30.0 psf (ground snow); Pf=23.1 psf (flat roof snow: Lumber DOL=1.15 Plate DOL=1.15); Category II; Exp B; Partially Exp.; Ct=1.10, Lu=50-0-0
 - Unbalanced snow loads have been considered for this design.
 - This truss has been designed for greater of min roof live load of 12.0 psf or 1.00 times flat roof load of 23.1 psf on overhangs non-concurrent with other live loads.
 - Provide adequate drainage to prevent water ponding.
 - This truss has been designed for a 10.0 psf bottom chord live load nonconcurrent with any other live loads.
 - * This truss has been designed for a live load of 20.0psf on the bottom chord in all areas where a rectangle 3-6-0 tall by 2-0-0 wide will fit between the bottom chord and any other members, with BCDL = 10.0psf.
 - Ceiling dead load (5.0 psf) on member(s). 23-25, 23-24, 20-24, 20-21, 9-21; Wall dead load (5.0psf) on member(s).19-25, 17-20
 - Bottom chord live load (40.0 psf) and additional bottom chord dead load (5.0 psf) applied only to room. 17-19

Continued on page 2

Job	Truss	Truss Type	Qty	Ply	GARY ROBINSON-LOT 73 SOUTH CREEK WOODLAKE MODEL ROOF
20-6466-A	AT02	Attic	3	1	Job Reference (optional)

Riverside Roof Truss, LLC, Danville, VA. 24541

Run: 8.330 s Feb 24 2020 Print: 8.330 s Feb 24 2020 MiTek Industries, Inc. Wed Nov 11 16:39:15 2020 Page 2
 ID:riFrQwqzJQyesEOjBg_H7VyKEle-?VldnHTUBw1pMNZ523s0HGyfsB5NMFbG9?Q6XyKCxw

NOTES-

- 11) Provide mechanical connection (by others) of truss to bearing plate capable of withstanding 100 lb uplift at joint(s) 2, 14 except (jt=lb) 12=167.
- 12) This truss is designed in accordance with the 2015 International Residential Code sections R502.11.1 and R802.10.2 and referenced standard ANSI/TPI 1.
- 13) Graphical purlin representation does not depict the size or the orientation of the purlin along the top and/or bottom chord.
- 14) Attic room checked for L/360 deflection.

LOAD CASE(S) Standard

Job	Truss	Truss Type	Qty	Ply	GARY ROBINSON-LOT 73 SOUTH CREEK WOODLAKE MODEL ROOF
20-6466-A	AT01	Attic	10	1	Job Reference (optional)

Riverside Roof Truss, LLC, Danville, VA. 24541 Run: 8.330 s Feb 24 2020 Print: 8.330 s Feb 24 2020 MiTek Industries, Inc. Wed Nov 11 16:39:16 2020 Page 1
 ID:riFrQwqzJQyesEOjBg_H7VyKEle-ThJ?_dT6yE9g_X8lbnNFqUVp9?Z56qykUolzezyKCxv

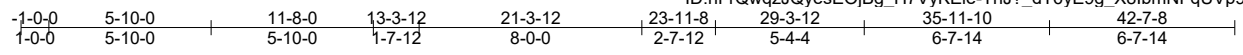

Scale = 1:82.8

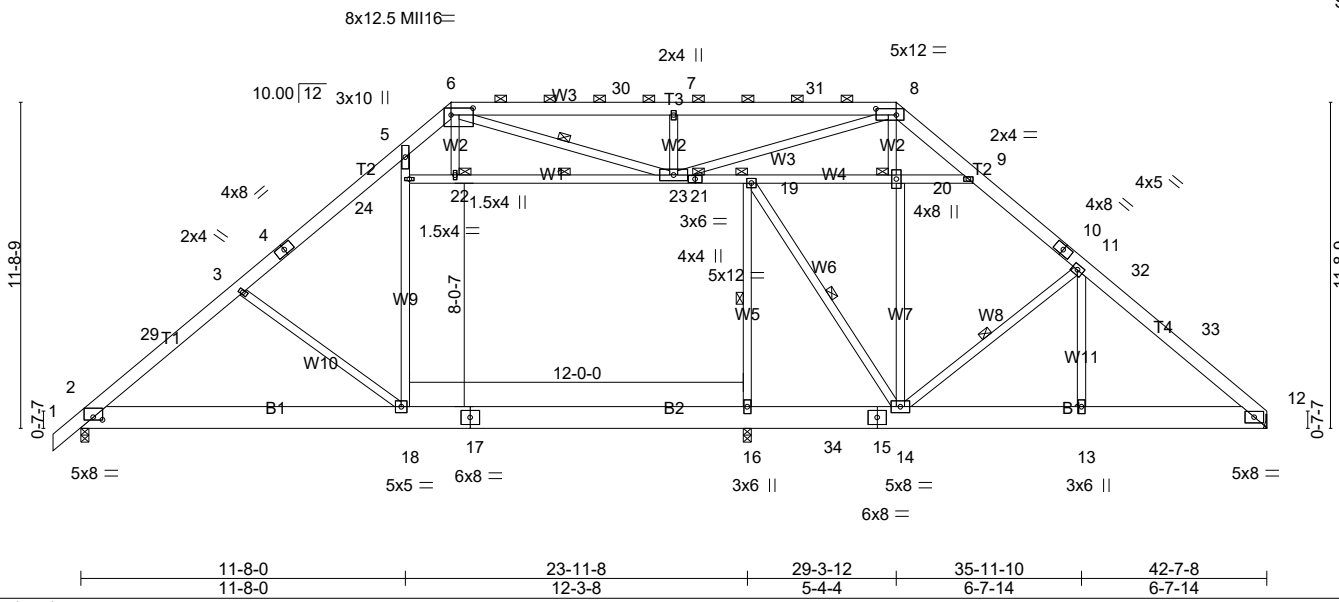

Plate Offsets (X,Y)-- [2:0-4-0,0-1-3], [6:0-9-8,0-3-0], [8:0-8-12,0-2-12]								
LOADING (psf)	SPACING -	CSI	DEFL.	in (loc)	l/defl	L/d	PLATES	GRIP
TCLL (roof) 30.0	2-0-0	TC 0.72	Vert(LL) -0.26	16-18	>999	360	MT20	244/190
Snow (Pf/Pg) 23.1/30.0	Plate Grip DOL 1.15	BC 0.81	Vert(CT) -0.42	16-18	>691	240	MI16	174/126
TCDL 10.0	Lumber DOL 1.15	WB 0.87	Horz(CT) 0.05	12	n/a	n/a		
BCLL 0.0 *	Rep Stress Incr YES	Matrix-MS	Attic -0.14	16-18	1061	360		
BCDL 10.0	Code IRC2015/TPI2014						Weight: 435 lb	FT = 20%

LUMBER-
 TOP CHORD 2x6 SP No.2 *Except*
 T2: 2x6 SP 2400F 2.0E
 BOT CHORD 2x10 SP No.2 *Except*
 B2: 2x10 SP No.1
 WEBS 2x4 SP No.3 *Except*
 W9,W5,W4,W1: 2x4 SP No.2

BRACING-
 TOP CHORD Structural wood sheathing directly applied or 3-10-7 oc purlins, except 2-0-0 oc purlins (3-2-2 max.): 6-8.
 BOT CHORD Rigid ceiling directly applied or 9-10-2 oc bracing.
 WEBS 1 Row at midpt 16-19, 11-14, 22-23, 14-19, 6-23
 JOINTS 1 Brace at Jt(s): 19, 20, 22, 23

MiTek recommends that Stabilizers and required cross bracing be installed during truss erection, in accordance with Stabilizer Installation guide.

REACTIONS. (lb/size) 2=1868/0-3-8 (min. 0-2-9), 16=695/0-3-8 (min. 0-1-8), 12=1671/Mechanical
 Max Horz 2=290(LC 13)
 Max Uplift 2=-136(LC 16), 16=-5(LC 17), 12=-56(LC 16)
 Max Grav 2=2161(LC 40), 16=1200(LC 58), 12=1954(LC 40)

FORCES. (lb) - Max. Comp./Max. Ten. - All forces 250 (lb) or less except when shown.
 TOP CHORD 2-29=-2951/187, 3-29=-2753/208, 3-4=-2607/168, 4-5=-2452/202, 5-6=-2023/295,
 6-30=-2964/488, 7-30=-2964/488, 7-31=-2964/488, 8-31=-2964/488, 8-9=-1761/194,
 9-10=-2060/294, 10-11=-2156/268, 11-32=-2466/271, 32-33=-2587/249, 12-33=-2757/244
 BOT CHORD 2-18=-220/2395, 17-18=-119/1900, 16-17=-119/1900, 16-34=-119/1900, 15-34=-119/1900,
 14-15=-119/1900, 13-14=-79/1987, 12-13=-79/1987
 WEBS 3-18=-826/264, 18-24=0/1062, 5-24=0/921, 16-19=-400/408, 14-20=-19/503,
 11-14=-621/207, 11-13=0/335, 21-23=-905/133, 19-21=-905/133, 19-20=-656/163,
 9-20=-662/162, 14-19=-797/210, 8-20=0/504, 7-23=-1068/262, 6-23=-527/1287,
 8-23=-318/1731

- NOTES-**
- Unbalanced roof live loads have been considered for this design.
 - Wind: ASCE 7-10; Vult=130mph (3-second gust) Vasd=103mph; TCCL=6.0psf; BCDL=6.0psf; h=25ft; Cat. II; Exp B; Enclosed; MWFRS (envelope) gable end zone and C-C Exterior(2) zone; cantilever left and right exposed; end vertical left and right exposed; C-C for members and forces & MWFRS for reactions shown; Lumber DOL=1.60 plate grip DOL=1.60
 - TCCL: ASCE 7-10; Pr=30.0 psf (roof live load: Lumber DOL=1.15 Plate DOL=1.15); Pg=30.0 psf (ground snow); Pf=23.1 psf (flat roof snow: Lumber DOL=1.15 Plate DOL=1.15); Category II; Exp B; Partially Exp.; Ct=1.10, Lu=50-0-0
 - Unbalanced snow loads have been considered for this design.
 - This truss has been designed for greater of min roof live load of 12.0 psf or 1.00 times flat roof load of 23.1 psf on overhangs non-concurrent with other live loads.
 - Provide adequate drainage to prevent water ponding.
 - All plates are MT20 plates unless otherwise indicated.
 - This truss has been designed for a 10.0 psf bottom chord live load nonconcurrent with any other live loads.
 - * This truss has been designed for a live load of 20.0psf on the bottom chord in all areas where a rectangle 3-6-0 tall by 2-0-0 wide will fit between the bottom chord and any other members, with BCDL = 10.0psf.
 - Ceiling dead load (5.0 psf) on member(s). 22-24, 22-23, 19-23, 19-20, 9-20; Wall dead load (5.0psf) on member(s).18-24, 16-19
 - Bottom chord live load (40.0 psf) and additional bottom chord dead load (5.0 psf) applied only to room. 16-18
 - Refer to girder(s) for truss to truss connections.

Continued on page 2

Job	Truss	Truss Type	Qty	Ply	GARY ROBINSON-LOT 73 SOUTH CREEK WOODLAKE MODEL ROOF
20-6466-A	AT01	Attic	10	1	Job Reference (optional)

Riverside Roof Truss, LLC, Danville, VA. 24541

Run: 8.330 s Feb 24 2020 Print: 8.330 s Feb 24 2020 MiTek Industries, Inc. Wed Nov 11 16:39:16 2020 Page 2
 ID:riFrQwqzJQyesEOjBg_H7VyKEle-ThJ?_dT6yE9g_X8lbnNFqUVp9?Z56qykUolzezyKCxv

NOTES-

- 13) Provide mechanical connection (by others) of truss to bearing plate capable of withstanding 100 lb uplift at joint(s) 16, 12 except (jt=lb) 2=136.
- 14) This truss is designed in accordance with the 2015 International Residential Code sections R502.11.1 and R802.10.2 and referenced standard ANSI/TPI 1.
- 15) Graphical purlin representation does not depict the size or the orientation of the purlin along the top and/or bottom chord.
- 16) Attic room checked for L/360 deflection.

LOAD CASE(S) Standard