

Job	Truss	Truss Type	Qty	Ply	H&H-NC/Wayfare/
MASTER	A01	HALF HIP GIRDER	2	2	

Builders FirstSource, N. Charleston, SC

Run: 7.640 s Apr 22 2016 Print: 7.640 s Apr 22 2016 MITek Industries, Inc. Wed Jan 10 11:33:24 2018 Page 1
ID:5gbe_Q0JNoiH4zfeQivLHzQqXF-0pSq4CH4uqxD?XZL?LbfVImLgJ4191SjTguJ_qzwaf

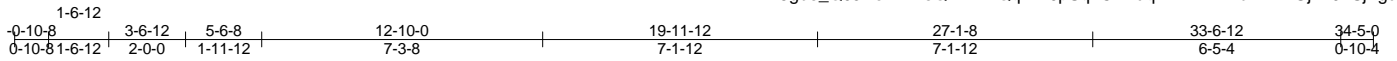

Scale = 1:59.8

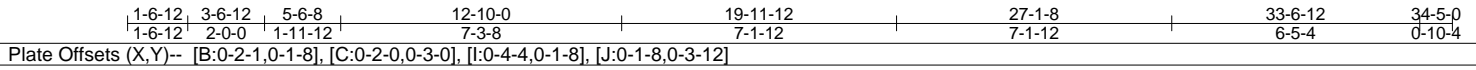
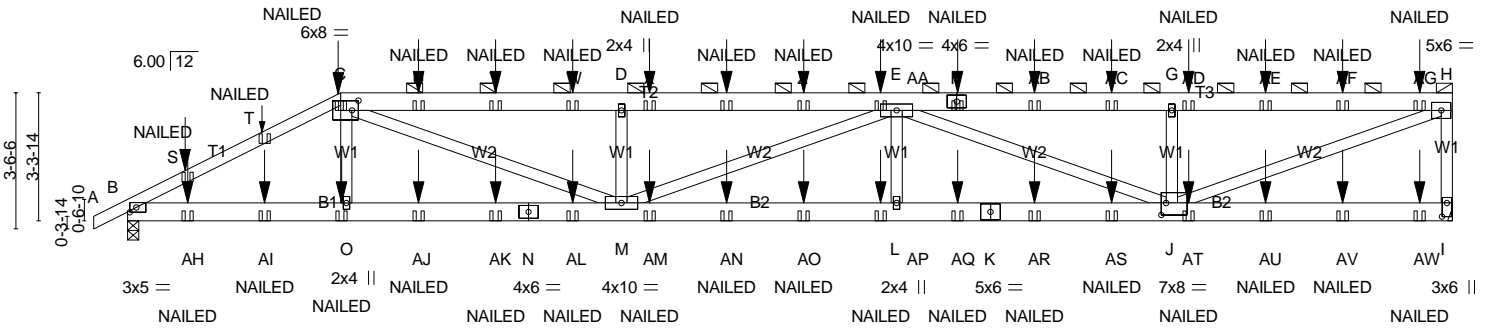

LOADING (psf)	SPACING-	CSI.	DEFL.	PLATES	GRIP
TCLL 20.0	2-0-0	TC 0.52	in (loc) l/defl L/d	MT20	244/190
TCDL 10.0	Plate Grip DOL 1.15	BC 0.79	Vert(LL) -0.24 L-M >999 360		
BCLL 0.0 *	Lumber DOL 1.15	WB 0.70	Vert(TL) -0.62 L-M >668 240		
BCDL 10.0	Rep Stress Incr NO	(Matrix-M)	Horz(TL) 0.10 I n/a n/a		
	Code IRC2009/TPI2007		Wind(LL) 0.43 L-M >946 240		Weight: 440 lb FT = 20%

LUMBER-	BRACING-
TOP CHORD 2x6 SP No.2 *Except* T1: 2x4 SP No.2	TOP CHORD Structural wood sheathing directly applied or 5-7-12 oc purlins, except end verticals, and 2-0-0 oc purlins (5-2-3 max.): C-H.
BOT CHORD 2x6 SP No.2	BOT CHORD Rigid ceiling directly applied or 7-6-4 oc bracing.
WEBS 2x4 SP No.2	

REACTIONS. (lb/size) I=2571/Mechanical, B=2542/0-3-8 (min. 0-1-8)
Max Horz B=206(LC 16)
Max Uplift=-1537(LC 5), B=-1411(LC 5)

FORCES. (lb) - Max. Comp./Max. Ten. - All forces 250 (lb) or less except when shown.
TOP CHORD B-S=-4664/2645, S-T=-4563/2623, C-T=-4550/2629, C-U=-7265/4319, U-V=-7266/4320,
V-W=-7268/4321, D-W=-7270/4321, D-X=-7266/4317, X-Y=-7266/4317, Y-Z=-7266/4317,
Z-AA=-7266/4317, E-AA=-7266/4317, E-F=-5189/3113, F-AB=-5189/3113, AB-AC=-5189/3113,
G-AC=-5189/3113, G-AD=-5189/3113, AD-AE=-5189/3113, AE-AF=-5189/3113,
AF-AG=-5189/3113, H-AG=-5189/3113, H-I=-2427/1575
BOT CHORD B-AH=-2473/4082, AH-AI=-2473/4082, O-AI=-2473/4082, O-AJ=-2470/4095, AJ-AK=-2470/4095,
N-AK=-2470/4095, N-AL=-2470/4095, M-AL=-2470/4095, M-AM=-4526/7509, AM-AN=-4526/7509,
AN-AO=-4526/7509, AO-AP=-4526/7509, L-AP=-4526/7509, L-AQ=-4526/7509,
K-AQ=-4526/7509, K-AR=-4526/7509, AR-AS=-4526/7509, J-AS=-4526/7509
WEBS C-O=0/406, C-M=-2129/3453, D-M=-944/883, E-M=-280/187, E-L=0/430, E-J=-2499/1495,
G-J=-867/839, H-J=-3274/5479

- NOTES-**
- 2-ply truss to be connected together with 10d (0.131"x3") nails as follows:
Top chords connected as follows: 2x4 - 1 row at 0-9-0 oc, 2x6 - 2 rows staggered at 0-9-0 oc.
Bottom chords connected as follows: 2x6 - 2 rows staggered at 0-9-0 oc.
Webs connected as follows: 2x4 - 1 row at 0-9-0 oc.
 - All loads are considered equally applied to all plies, except if noted as front (F) or back (B) face in the LOAD CASE(S) section. Ply to ply connections have been provided to distribute only loads noted as (F) or (B), unless otherwise indicated.
 - Unbalanced roof live loads have been considered for this design.
 - Wind: ASCE 7-05; 130mph; TCDL=6.0psf; BCDL=6.0psf; h=25ft; Cat. II; Exp C; enclosed; MWFRS (low-rise); end vertical left and right exposed; Lumber DOL=1.60 plate grip DOL=1.60
 - This truss has been designed for basic load combinations, which include cases with reductions for multiple concurrent live loads.
 - Provide adequate drainage to prevent water ponding.
 - This truss has been designed for a 10.0 psf bottom chord live load nonconcurrent with any other live loads.
 - * This truss has been designed for a live load of 20.0psf on the bottom chord in all areas where a rectangle 3-6-0 tall by 2-0-0 wide will fit between the bottom chord and any other members.
 - Refer to girder(s) for truss connections.
 - Provide mechanical connection (by others) of truss to bearing plate capable of withstanding 100 lb uplift at joint(s) except (jt=lb) I=1537, B=1411.
 - This truss is designed in accordance with the 2009 International Residential Code sections R502.11.1 and R802.10.2 and referenced standard ANSI/TPI 1.

Continued on page 2

Job	Truss	Truss Type	Qty	Ply	H&H-NC/Wayfare/
MASTER	A01	HALF HIP GIRDER	2	2	Job Reference (optional)

Builders FirstSource, N. Charleston, SC

Run: 7.640 s Apr 22 2016 Print: 7.640 s Apr 22 2016 MiTek Industries, Inc. Wed Jan 10 11:33:25 2018 Page 2
ID:5gbe_Q0JNoiH4zfeQirvLHzQqXF-U?0CHYlif734dh8YZ36u1zIW07QGuUishKesWGzwnae

NOTES-

- 12) "Semi-rigid pitchbreaks including heels" Member end fixity model was used in the analysis and design of this truss.
- 13) Graphical purlin representation does not depict the size or the orientation of the purlin along the top and/or bottom chord.
- 14) "NAILED" indicates 3-10d (0.148"x3") or 3-12d (0.148"x3.25") toe-nails. For more details refer to MiTek's ST-TOENAIL Detail.

LOAD CASE(S) Standard

1) Dead + Roof Live (balanced): Lumber Increase=1.15, Plate Increase=1.15

Uniform Loads (plf)

Vert: A-C=-60, C-H=-60, I-P=-20

Concentrated Loads (lb)

Vert: C=-106(F) F=-106(F) O=-30(F) S=-69(F) U=-106(F) V=-106(F) W=-106(F) X=-106(F) Y=-106(F) Z=-106(F) AA=-106(F) AB=-106(F) AC=-106(F) AD=-106(F)
AE=-106(F) AF=-106(F) AG=-115(F) AH=-53(F) AI=-136(F) AJ=-30(F) AK=-30(F) AL=-30(F) AM=-30(F) AN=-30(F) AO=-30(F) AP=-30(F) AQ=-30(F) AR=-30(F)
AS=-30(F) AT=-30(F) AU=-30(F) AV=-30(F) AW=-33(F)

Job	Truss	Truss Type	Qty	Ply	H&H-NC/Wayfare/
MASTER	A02	HALF HIP	2	1	

Builders FirstSource, N. Charleston, SC

Run: 7.640 s Apr 22 2016 Print: 7.640 s Apr 22 2016 MiTek Industries, Inc. Wed Jan 10 11:33:25 2018 Page 1
ID:5gbe_Q0JNoiH4zfeQirvLHzQqXF-U?0CHYIif734dh8YZ36u1zIT47OjuRFshKesWGzwnae

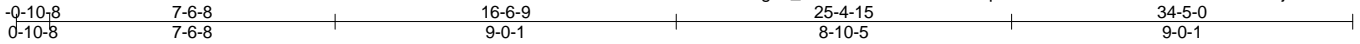

Scale = 1:60.8

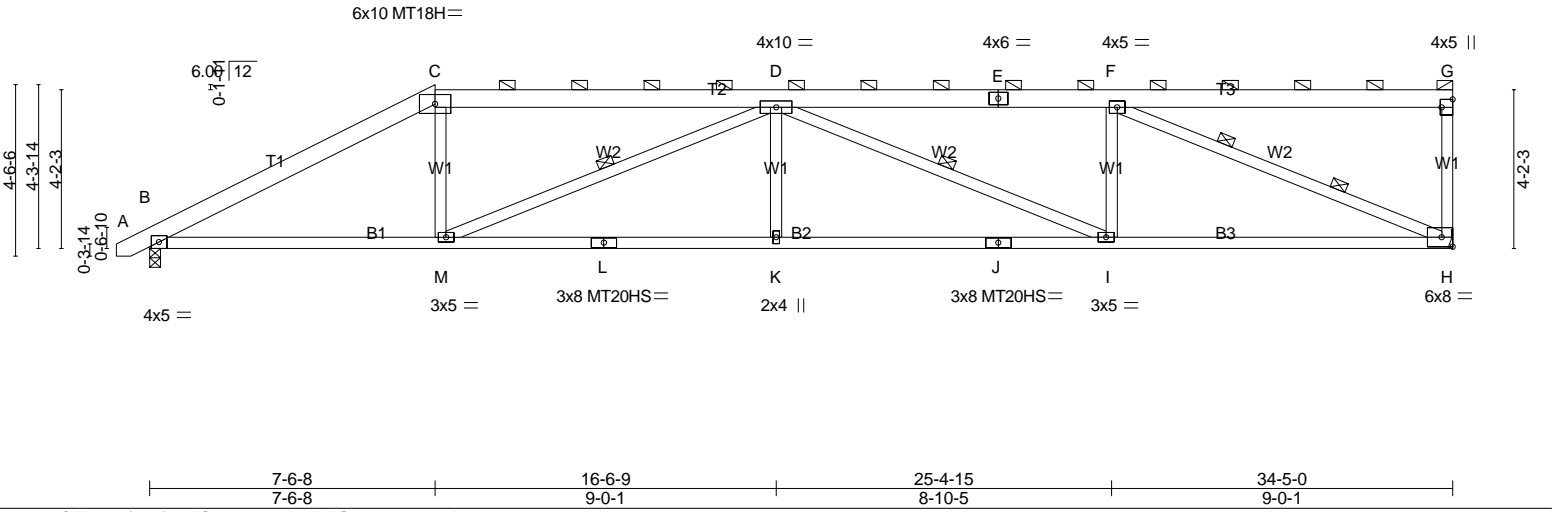

Plate Offsets (X,Y)-- [C:0-0-0,0-0-0], [G:Edge,0-3-8]

LOADING (psf)	SPACING-	2-0-0	CSI.	DEFL.	in	(loc)	l/defl	L/d	PLATES	GRIP
TCLL 20.0	Plate Grip DOL	1.15	TC 0.71	Vert(LL)	-0.21	I-K	>999	360	MT20	244/190
TCDL 10.0	Lumber DOL	1.15	BC 0.96	Vert(TL)	-0.60	I-K	>687	240	MT20HS	187/143
BCLL 0.0 *	Rep Stress Incr	YES	WB 0.86	Horz(TL)	0.18	H	n/a	n/a	MT18H	244/190
BCDL 10.0	Code IRC2009/TPI2007		(Matrix-S)	Wind(LL)	0.34	I-K	>999	240		Weight: 198 lb FT = 20%

LUMBER-
 TOP CHORD 2x6 SP No.2
 BOT CHORD 2x4 SP No.1 *Except*
 B2: 2x4 SP No.2
 WEBS 2x4 SP No.3 *Except*
 W2: 2x4 SP No.2

BRACING-
 TOP CHORD Structural wood sheathing directly applied, except end verticals, and 2-0-0 oc purlins (4-3-8 max.): C-G.
 BOT CHORD Rigid ceiling directly applied.
 WEBS 1 Row at midpt D-M, D-I
 2 Rows at 1/3 pts F-H

MiTek recommends that Stabilizers and required cross bracing be installed during truss erection, in accordance with Stabilizer Installation guide.

REACTIONS. (lb/size) H=1370/Mechanical, B=1413/0-3-8 (min. 0-1-11)
 Max Horz B=255(LC 8)
 Max Uplift H=620(LC 7), B=516(LC 7)

FORCES. (lb) - Max. Comp./Max. Ten. - All forces 250 (lb) or less except when shown.
 TOP CHORD B-C=-2517/2016, C-D=-2206/1976, D-E=-2503/2096, E-F=-2503/2096, G-H=-237/295
 BOT CHORD B-M=-1965/2182, L-M=-2715/3196, K-L=-2715/3196, J-K=-2715/3196, I-J=-2715/3196,
 H-I=-2096/2503
 WEBS C-M=-232/646, D-M=-1193/808, D-K=0/351, D-I=-755/673, F-I=-146/598, F-H=-2655/2241

- NOTES-**
- 1) Unbalanced roof live loads have been considered for this design.
 - 2) Wind: ASCE 7-05; 130mph; TCDL=6.0psf; BCDL=6.0psf; h=25ft; Cat. II; Exp C; enclosed; MWFRS (low-rise) and C-C Exterior(2) zone; end vertical left exposed; C-C for members and forces & MWFRS for reactions shown; Lumber DOL=1.60 plate grip DOL=1.60
 - 3) This truss has been designed for basic load combinations, which include cases with reductions for multiple concurrent live loads.
 - 4) Provide adequate drainage to prevent water ponding.
 - 5) All plates are MT20 plates unless otherwise indicated.
 - 6) This truss has been designed for a 10.0 psf bottom chord live load nonconcurrent with any other live loads.
 - 7) * This truss has been designed for a live load of 20.0psf on the bottom chord in all areas where a rectangle 3-6-0 tall by 2-0-0 wide will fit between the bottom chord and any other members.
 - 8) Refer to girder(s) for truss to truss connections.
 - 9) Provide mechanical connection (by others) of truss to bearing plate capable of withstanding 100 lb uplift at joint(s) except (jt=lb) H=620, B=516.
 - 10) This truss is designed in accordance with the 2009 International Residential Code sections R502.11.1 and R802.10.2 and referenced standard ANSI/TPI 1.
 - 11) This truss design requires that a minimum of 7/16" structural wood sheathing be applied directly to the top chord and 1/2" gypsum sheetrock be applied directly to the bottom chord.
 - 12) Graphical purlin representation does not depict the size or the orientation of the purlin along the top and/or bottom chord.

LOAD CASE(S) Standard

Job	Truss	Truss Type	Qty	Ply	H&H-NC/Wayfare/
MASTER	A03	HIP	2	1	

Builders FirstSource, N. Charleston, SC

Run: 7.640 s Apr 22 2016 Print: 7.640 s Apr 22 2016 MiTek Industries, Inc. Wed Jan 10 11:33:26 2018 Page 1
ID:5gbe_Q0JNoiH4zfeQirvLHzQqXF-yCabUuJKQRxBxErik7me7aArc7WpHd_??w_NQ2jzwnad

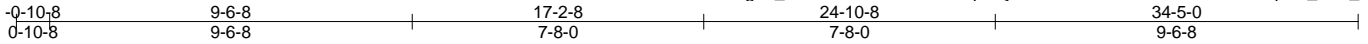

Scale = 1:60.6

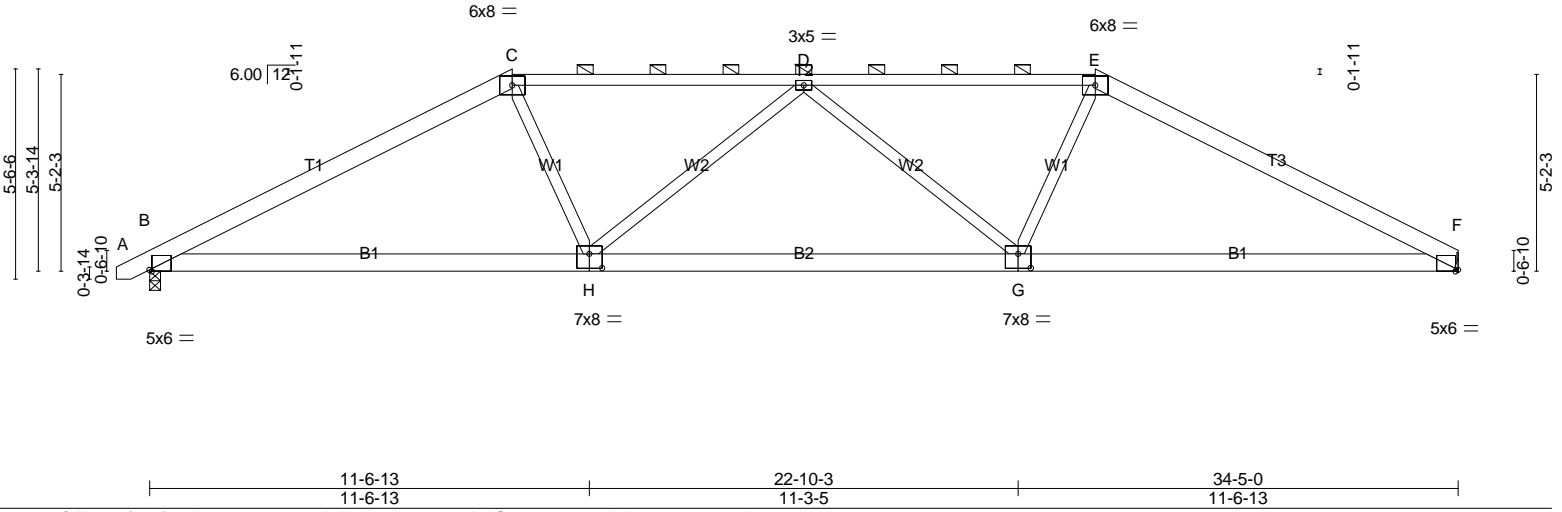

Plate Offsets (X,Y)-- [B:0-0-12,Edge], [F:0-0-12,Edge], [G:0-4-0,0-4-8], [H:0-4-0,0-4-8]

LOADING (psf)	SPACING-	2-0-0	CSI.	DEFL.	in	(loc)	l/defl	L/d	PLATES	GRIP
TCLL 20.0	Plate Grip DOL	1.15	TC 0.88	Vert(LL)	-0.10	G-K	>999	360	MT20	244/190
TCDL 10.0	Lumber DOL	1.15	BC 0.62	Vert(TL)	-0.32	G-H	>999	240		
BCLL 0.0 *	Rep Stress Incr	YES	WB 0.51	Horz(TL)	0.09	F	n/a	n/a		
BCDL 10.0	Code IRC2009/TPI2007		(Matrix-S)	Wind(LL)	0.19	G-K	>999	240		
									Weight: 192 lb	FT = 20%

LUMBER-
 TOP CHORD 2x6 SP No.2 *Except*
 T2: 2x4 SP No.2
 BOT CHORD 2x6 SP No.2
 WEBS 2x4 SP No.3

BRACING-
 TOP CHORD Structural wood sheathing directly applied, except
 2-0-0 oc purlins (2-2-0 max.): C-E.
 BOT CHORD Rigid ceiling directly applied.

MiTek recommends that Stabilizers and required cross bracing be installed during truss erection, in accordance with Stabilizer Installation guide.

REACTIONS. (lb/size) F=1376/Mechanical, B=1419/0-3-8 (min. 0-1-11)
 Max Horz B=138(LC 8)
 Max Uplift F=-429(LC 6), B=-481(LC 8)

FORCES. (lb) - Max. Comp./Max. Ten. - All forces 250 (lb) or less except when shown.
 TOP CHORD B-C=-2297/1909, C-D=-2160/1973, D-E=-2164/1977, E-F=-2301/1913
 BOT CHORD B-H=-1436/1956, G-H=-1872/2443, F-G=-1441/1961
 WEBS C-H=-210/585, D-H=-467/466, D-G=-463/460, E-G=-210/585

- NOTES-**
- Unbalanced roof live loads have been considered for this design.
 - Wind: ASCE 7-05; 130mph; TCDL=6.0psf; BCDL=6.0psf; h=25ft; Cat. II; Exp C; enclosed; MWFRS (low-rise) and C-C Exterior(2) zone; end vertical left and right exposed; C-C for members and forces & MWFRS for reactions shown; Lumber DOL=1.60 plate grip DOL=1.60
 - This truss has been designed for basic load combinations, which include cases with reductions for multiple concurrent live loads.
 - Provide adequate drainage to prevent water ponding.
 - This truss has been designed for a 10.0 psf bottom chord live load nonconcurrent with any other live loads.
 - * This truss has been designed for a live load of 20.0psf on the bottom chord in all areas where a rectangle 3-6-0 tall by 2-0-0 wide will fit between the bottom chord and any other members.
 - Refer to girder(s) for truss to truss connections.
 - Provide mechanical connection (by others) of truss to bearing plate capable of withstanding 100 lb uplift at joint(s) except (jt=lb) F=429, B=481.
 - This truss is designed in accordance with the 2009 International Residential Code sections R502.11.1 and R802.10.2 and referenced standard ANSI/TPI 1.
 - This truss design requires that a minimum of 7/16" structural wood sheathing be applied directly to the top chord and 1/2" gypsum sheetrock be applied directly to the bottom chord.
 - Graphical purlin representation does not depict the size or the orientation of the purlin along the top and/or bottom chord.

LOAD CASE(S) Standard

Job	Truss	Truss Type	Qty	Ply	H&H-NC/Wayfare/
MASTER	A04	HIP	2	1	

Builders FirstSource, N. Charleston, SC

Run: 7.640 s Apr 22 2016 Print: 7.640 s Apr 22 2016 MiTek Industries, Inc. Wed Jan 10 11:33:26 2018 Page 1
 ID:5gbe_Q0JNoiH4zfeQirvLHzQqXF-yCabUuJKQRBxErik7me7aArfDWocd1Z?w_NQ2jzwnad

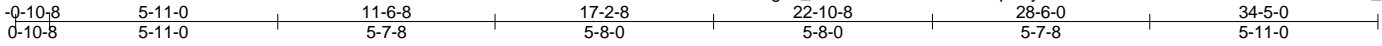

Scale = 1:59.7

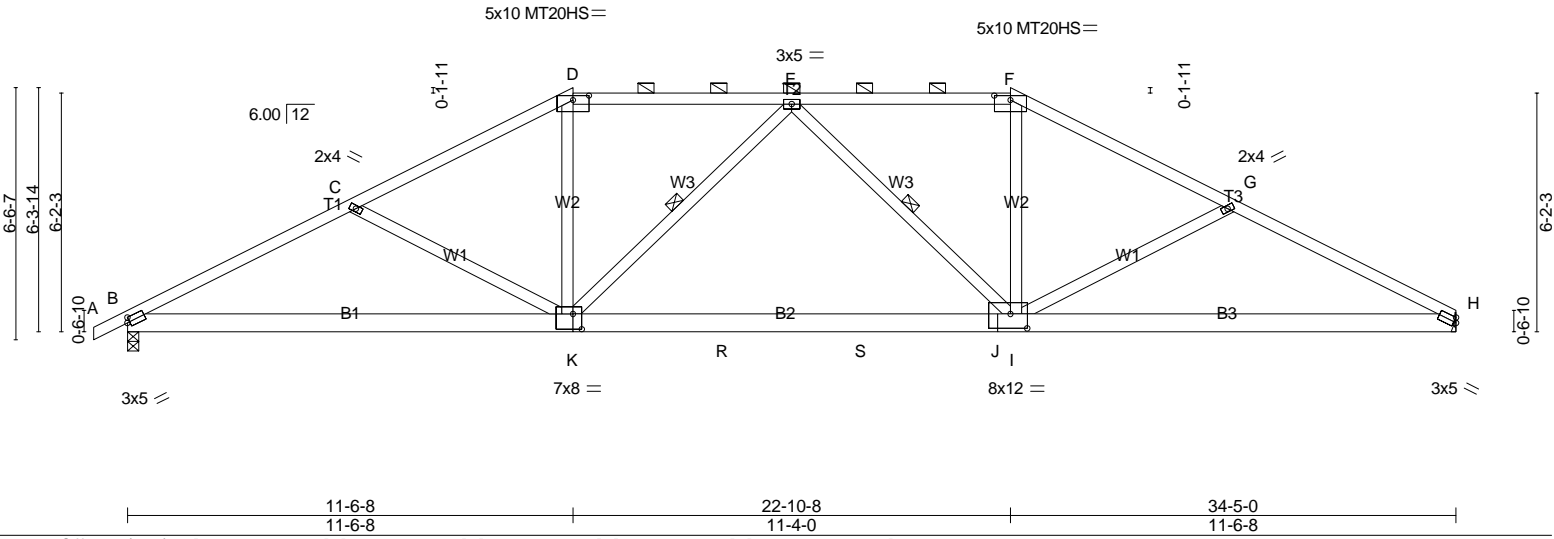

Plate Offsets (X,Y)-- [B:0-0-12,0-1-8], [D:0-5-0,0-1-7], [F:0-5-0,0-1-7], [J:0-5-4,0-4-8], [K:0-2-12,0-4-12]					
LOADING (psf)	SPACING- 2-0-0	CSI.	DEFL. in (loc) l/defl L/d	PLATES	GRIP
TCLL 20.0	Plate Grip DOL 1.15	TC 0.69	Vert(LL) -0.22 I-K >999 360	MT20	244/190
TCDL 10.0	Lumber DOL 1.15	BC 0.66	Vert(TL) -0.45 I-K >918 240	MT20HS	187/143
BCLL 0.0 *	Rep Stress Incr YES	WB 0.28	Horz(TL) 0.09 H n/a n/a		
BCDL 10.0	Code IRC2009/TPI2007	(Matrix-S)	Wind(LL) 0.20 I-K >999 240		Weight: 195 lb FT = 20%

LUMBER-
 TOP CHORD 2x4 SP No.2
 BOT CHORD 2x6 SP No.2
 WEBS 2x4 SP No.3

BRACING-
 TOP CHORD Structural wood sheathing directly applied, except 2-0-0 oc purlins (3-11-15 max.): D-F.
 BOT CHORD Rigid ceiling directly applied.
 WEBS 1 Row at midpt E-K, E-I

MiTek recommends that Stabilizers and required cross bracing be installed during truss erection, in accordance with Stabilizer Installation guide.

REACTIONS. (lb/size) H=1376/Mechanical, B=1430/0-3-8 (min. 0-1-11)
 Max Horz B=169(LC 8)
 Max UpliftH=-447(LC 9), B=-521(LC 8)

FORCES. (lb) - Max. Comp./Max. Ten. - All forces 250 (lb) or less except when shown.
 TOP CHORD B-C=-2490/2250, C-D=-2140/1900, D-E=-1855/1822, E-F=-1849/1821, F-G=-2150/1910,
 G-H=-2496/2254
 BOT CHORD B-K=-1850/2167, K-R=-1511/2043, R-S=-1511/2043, J-S=-1511/2043, I-J=-1511/2043,
 H-I=-1855/2172
 WEBS C-K=-360/648, D-K=-395/607, E-K=-389/336, E-I=-397/332, F-I=-400/610, G-I=-359/647

- NOTES-**
- 1) Unbalanced roof live loads have been considered for this design.
 - 2) Wind: ASCE 7-05; 130mph; TCDL=6.0psf; BCDL=6.0psf; h=25ft; Cat. II; Exp C; enclosed; MWFRS (low-rise) and C-C Exterior(2) zone; end vertical left and right exposed; C-C for members and forces & MWFRS for reactions shown; Lumber DOL=1.60 plate grip DOL=1.60
 - 3) This truss has been designed for basic load combinations, which include cases with reductions for multiple concurrent live loads.
 - 4) Provide adequate drainage to prevent water ponding.
 - 5) All plates are MT20 plates unless otherwise indicated.
 - 6) This truss has been designed for a 10.0 psf bottom chord live load nonconcurrent with any other live loads.
 - 7) * This truss has been designed for a live load of 20.0psf on the bottom chord in all areas where a rectangle 3-6-0 tall by 2-0-0 wide will fit between the bottom chord and any other members, with BCDL = 10.0psf.
 - 8) Refer to girder(s) for truss to truss connections.
 - 9) Provide mechanical connection (by others) of truss to bearing plate capable of withstanding 100 lb uplift at joint(s) except (jt=lb) H=447, B=521.
 - 10) This truss is designed in accordance with the 2009 International Residential Code sections R502.11.1 and R802.10.2 and referenced standard ANSI/TPI 1.
 - 11) This truss design requires that a minimum of 7/16" structural wood sheathing be applied directly to the top chord and 1/2" gypsum sheetrock be applied directly to the bottom chord.
 - 12) Graphical purlin representation does not depict the size or the orientation of the purlin along the top and/or bottom chord.

LOAD CASE(S) Standard

Job	Truss	Truss Type	Qty	Ply	H&H-NC/Wayfare/
MASTER	A05	HIP	2	1	

Builders FirstSource, N. Charleston, SC

Run: 7.640 s Apr 22 2016 Print: 7.640 s Apr 22 2016 MiTek Industries, Inc. Wed Jan 10 11:33:27 2018 Page 1
 ID:5gbe_Q0JNoiH4zfeQirvLHzQqXF-R08ziEJyAlJos?HwgT9M7OOmFw6uMRi99e7zb9zwnac

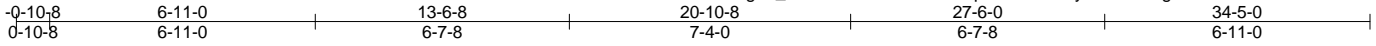

Scale = 1:60.1

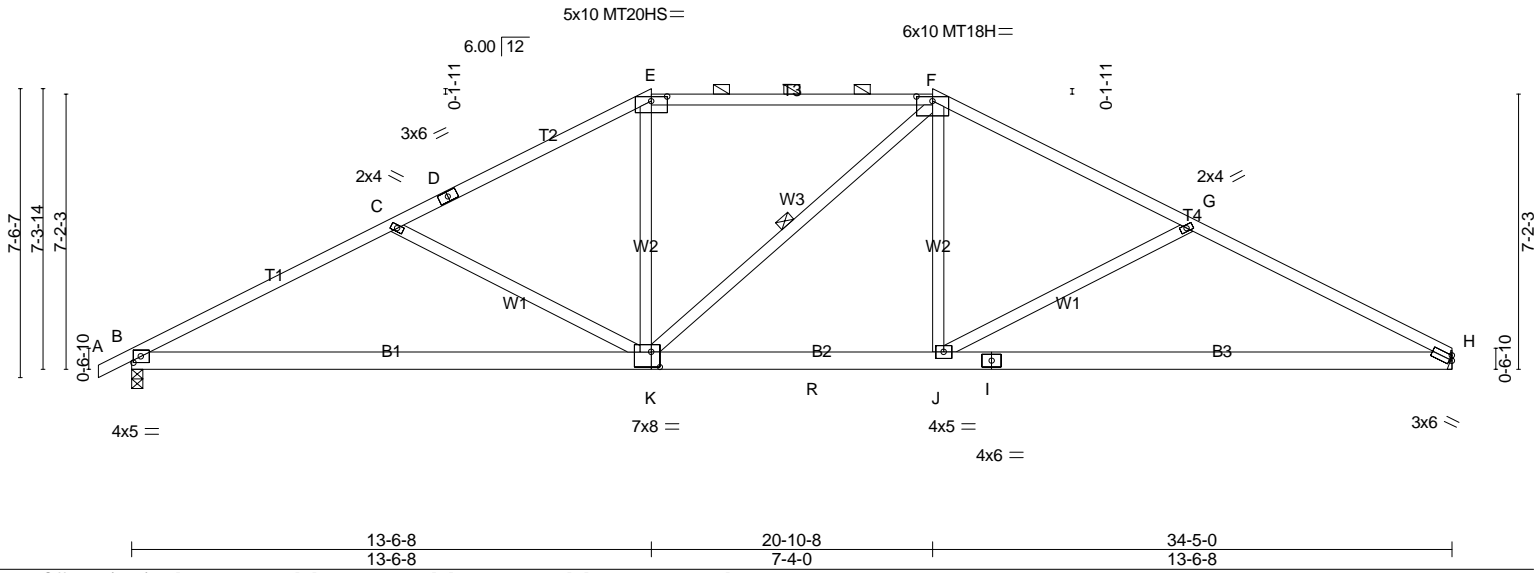

Plate Offsets (X,Y)-- [B:0-2-5,0-2-0], [E:0-5-0,0-1-7], [F:0-5-0,0-1-7], [K:0-2-12,0-4-12]

LOADING (psf)	SPACING-	2-0-0	CSI.	DEFL.	in	(loc)	l/defl	L/d	PLATES	GRIP
TCLL 20.0	Plate Grip DOL	1.15	TC 0.92	Vert(LL)	-0.24	K-Q	>999	360	MT20	244/190
TCDL 10.0	Lumber DOL	1.15	BC 0.78	Vert(TL)	-0.66	K-Q	>629	240	MT20HS	187/143
BCLL 0.0 *	Rep Stress Incr	YES	WB 0.48	Horz(TL)	0.07	H	n/a	n/a	MT18H	244/190
BCDL 10.0	Code IRC2009/TPI2007		(Matrix-S)	Wind(LL)	0.17	J-K	>999	240		Weight: 194 lb FT = 20%

LUMBER-
 TOP CHORD 2x4 SP No.2
 BOT CHORD 2x6 SP No.2
 WEBS 2x4 SP No.3

BRACING-
 TOP CHORD Structural wood sheathing directly applied, except 2-0-0 oc purlins (2-2-0 max.): E-F.
 BOT CHORD Rigid ceiling directly applied.
 WEBS 1 Row at midpt F-K

MiTek recommends that Stabilizers and required cross bracing be installed during truss erection, in accordance with Stabilizer Installation guide.

REACTIONS. (lb/size) H=1376/Mechanical, B=1430/0-3-8 (min. 0-1-11)
 Max Horz B=191(LC 8)
 Max UpliftH=-472(LC 9), B=-546(LC 8)

FORCES. (lb) - Max. Comp./Max. Ten. - All forces 250 (lb) or less except when shown.
 TOP CHORD B-C=-2419/2249, C-D=-1991/1797, D-E=-1896/1827, E-F=-1705/1778, F-G=-1999/1838, G-H=-2427/2255
 BOT CHORD B-K=-1824/2097, K-R=-1140/1704, J-R=-1140/1704, I-J=-1831/2105, H-I=-1831/2105
 WEBS C-K=-447/778, E-K=-241/510, F-J=-249/508, G-J=-448/777

- NOTES-**
- 1) Unbalanced roof live loads have been considered for this design.
 - 2) Wind: ASCE 7-05; 130mph; TCDL=6.0psf; BCDL=6.0psf; h=25ft; Cat. II; Exp C; enclosed; MWFRS (low-rise) and C-C Exterior(2) zone; end vertical left and right exposed; C-C for members and forces & MWFRS for reactions shown; Lumber DOL=1.60 plate grip DOL=1.60
 - 3) This truss has been designed for basic load combinations, which include cases with reductions for multiple concurrent live loads.
 - 4) Provide adequate drainage to prevent water ponding.
 - 5) All plates are MT20 plates unless otherwise indicated.
 - 6) This truss has been designed for a 10.0 psf bottom chord live load nonconcurrent with any other live loads.
 - 7) * This truss has been designed for a live load of 20.0psf on the bottom chord in all areas where a rectangle 3-6-0 tall by 2-0-0 wide will fit between the bottom chord and any other members, with BCDL = 10.0psf.
 - 8) Refer to girder(s) for truss to truss connections.
 - 9) Provide mechanical connection (by others) of truss to bearing plate capable of withstanding 100 lb uplift at joint(s) except (jt=lb) H=472, B=546.
 - 10) This truss is designed in accordance with the 2009 International Residential Code sections R502.11.1 and R802.10.2 and referenced standard ANSI/TPI 1.
 - 11) This truss design requires that a minimum of 7/16" structural wood sheathing be applied directly to the top chord and 1/2" gypsum sheetrock be applied directly to the bottom chord.
 - 12) Graphical purlin representation does not depict the size or the orientation of the purlin along the top and/or bottom chord.

LOAD CASE(S) Standard

Job	Truss	Truss Type	Qty	Ply	H&H-NC/Wayfare/
MASTER	A06	HIP	2	1	

Builders FirstSource, N. Charleston, SC

Run: 7.640 s Apr 22 2016 Print: 7.640 s Apr 22 2016 MiTek Industries, Inc. Wed Jan 10 11:33:27 2018 Page 1
ID:5gbe_Q0JNoiH4zfeQirvLHzQqXF-RO8ziEJyAJos?HwgT9M7O0mXw5kMMj99e7zb9zwnac

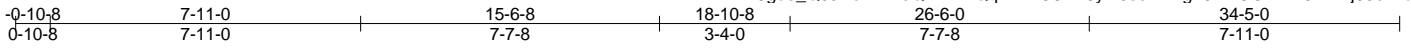

Scale = 1:58.8

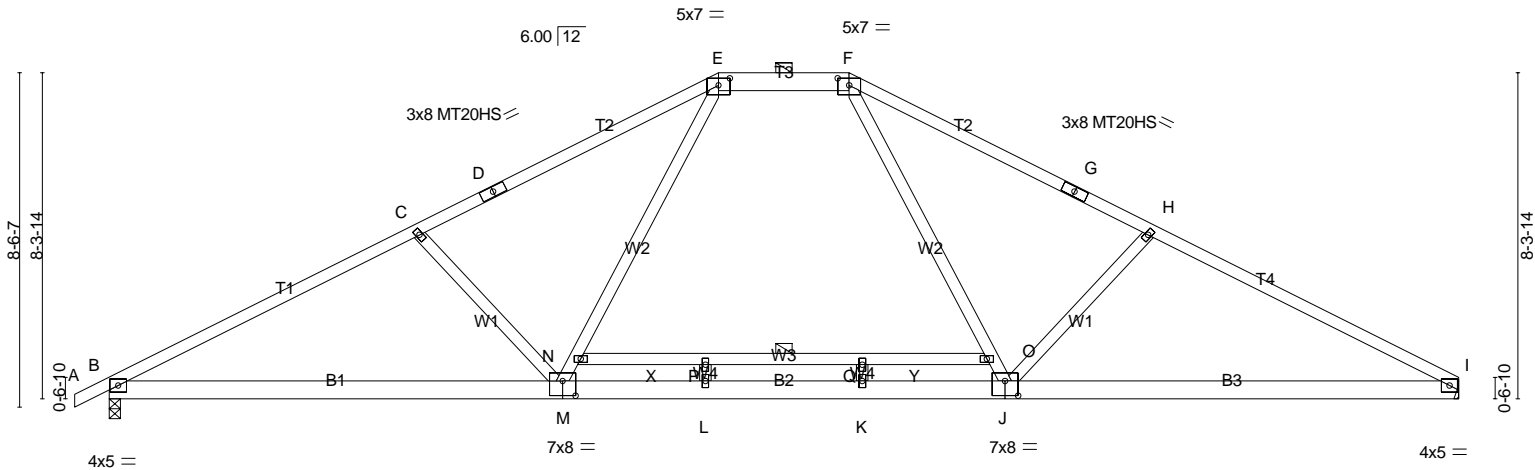

11-6-13	15-2-8	19-2-8	22-10-3	34-5-0
11-6-13	3-7-11	4-0-0	3-7-11	11-6-13

Plate Offsets (X,Y)-- [E:0-3-8,0-2-3], [F:0-3-8,0-2-3], [G:0-0-0,0-0-0], [J:0-4-0,0-4-8], [M:0-4-0,0-4-8]

LOADING (psf)	SPACING-	CSI.	DEFL.	in (loc)	l/defl	L/d	PLATES	GRIP
TCLL 20.0	2-0-0	TC 0.91	Vert(LL) -0.30	K-L	>999	360	MT20	244/190
TCDL 10.0	Plate Grip DOL 1.15	BC 0.86	Vert(TL) -0.49	K-L	>847	240	MT20HS	187/143
BCLL 0.0 *	Lumber DOL 1.15	WB 0.80	Horz(TL) 0.07	I	n/a	n/a		
BCDL 10.0	Rep Stress Incr NO	(Matrix-S)	Wind(LL) 0.26	M-T	>999	240		Weight: 199 lb FT = 20%
	Code IRC2009/TPI2007							

LUMBER-
TOP CHORD 2x4 SP No.2 *Except*
T3: 2x6 SP No.2, T1,T4: 2x4 SP No.1
BOT CHORD 2x6 SP No.2
WEBS 2x4 SP No.3 *Except*
W3: 2x4 SP No.2

BRACING-
TOP CHORD Structural wood sheathing directly applied, except
2-0-0 oc purlins (5-10-1 max.): E-F.
BOT CHORD Rigid ceiling directly applied.
WEBS 1 Row at midpt N-O

MiTek recommends that Stabilizers and required cross bracing be installed during truss erection, in accordance with Stabilizer Installation guide.

REACTIONS. (lb/size) B=1430/0-3-8 (min. 0-1-11), I=1376/Mechanical
Max Horz B=215(LC 8)
Max Uplift B=-566(LC 8), I=-492(LC 9)

FORCES. (lb) - Max. Comp./Max. Ten. - All forces 250 (lb) or less except when shown.
TOP CHORD B-C=-2425/2214, C-D=-2100/1992, D-E=-1989/2029, E-F=-1484/1727, F-G=-1991/2032,
G-H=-2103/1995, H-I=-2428/2218
BOT CHORD B-M=-1775/2090, L-M=-1032/1544, K-L=-1032/1544, J-K=-1032/1544, I-J=-1780/2093
WEBS C-M=-519/814, M-N=-510/770, E-N=-529/829, F-O=-535/831, J-O=-516/771, H-J=-521/817

- NOTES-**
- Unbalanced roof live loads have been considered for this design.
 - Wind: ASCE 7-05; 130mph; TCDL=6.0psf; BCDL=6.0psf; h=25ft; Cat. II; Exp C; enclosed; MWFRS (low-rise) and C-C Exterior(2) zone; end vertical left and right exposed; C-C for members and forces & MWFRS for reactions shown; Lumber DOL=1.60 plate grip DOL=1.60
 - This truss has been designed for basic load combinations, which include cases with reductions for multiple concurrent live loads.
 - Provide adequate drainage to prevent water ponding.
 - All plates are MT20 plates unless otherwise indicated.
 - All plates are 2x4 MT20 unless otherwise indicated.
 - This truss has been designed for a 10.0 psf bottom chord live load nonconcurrent with any other live loads.
 - * This truss has been designed for a live load of 20.0psf on the bottom chord in all areas where a rectangle 3-6-0 tall by 2-0-0 wide will fit between the bottom chord and any other members.
 - Refer to girder(s) for truss to truss connections.
 - Provide mechanical connection (by others) of truss to bearing plate capable of withstanding 100 lb uplift at joint(s) except (jt=lb) B=566, I=492.
 - This truss is designed in accordance with the 2009 International Residential Code sections R502.11.1 and R802.10.2 and referenced standard ANSI/TPI 1.
 - This truss design requires that a minimum of 7/16" structural wood sheathing be applied directly to the top chord and 1/2" gypsum sheetrock be applied directly to the bottom chord.
 - Graphical purlin representation does not depict the size or the orientation of the purlin along the top and/or bottom chord.

LOAD CASE(S) Standard
1) Dead + Roof Live (balanced): Lumber Increase=1.15, Plate Increase=1.15

Job	Truss	Truss Type	Qty	Ply	H&H-NC/Wayfare/
MASTER	A06	HIP	2	1	Job Reference (optional)

Builders FirstSource, N. Charleston, SC

Run: 7.640 s Apr 22 2016 Print: 7.640 s Apr 22 2016 MiTek Industries, Inc. Wed Jan 10 11:33:28 2018 Page 2
ID:5gbe_Q0JNoiH4zfeQirvLHzQqXF-vahLvaKax2RfU8s6EBgbfbwxGKRz5pzlOlsX7bzwnab

LOAD CASE(S) Standard

Uniform Loads (plf)

Vert: A-E=-60, E-F=-60, F-I=-60, R-U=-20

Job MASTER	Truss A07	Truss Type COMMON	Qty 2	Ply 1	H&H-NC/Wayfare/ Job Reference (optional)
---------------	--------------	----------------------	----------	----------	---

Builders FirstSource, N. Charleston, SC

Run: 7.640 s Apr 22 2016 Print: 7.640 s Apr 22 2016 MiTek Industries, Inc. Wed Jan 10 11:33:28 2018 Page 1
ID:5gbe_Q0JNoiH4zfeQirvLHzQqXF-vahLvaKax2RfU8s6EBgbfwwFKR35uTIOIsX7bznab

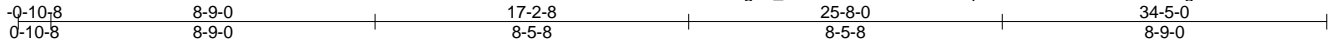

Scale = 1:62.1

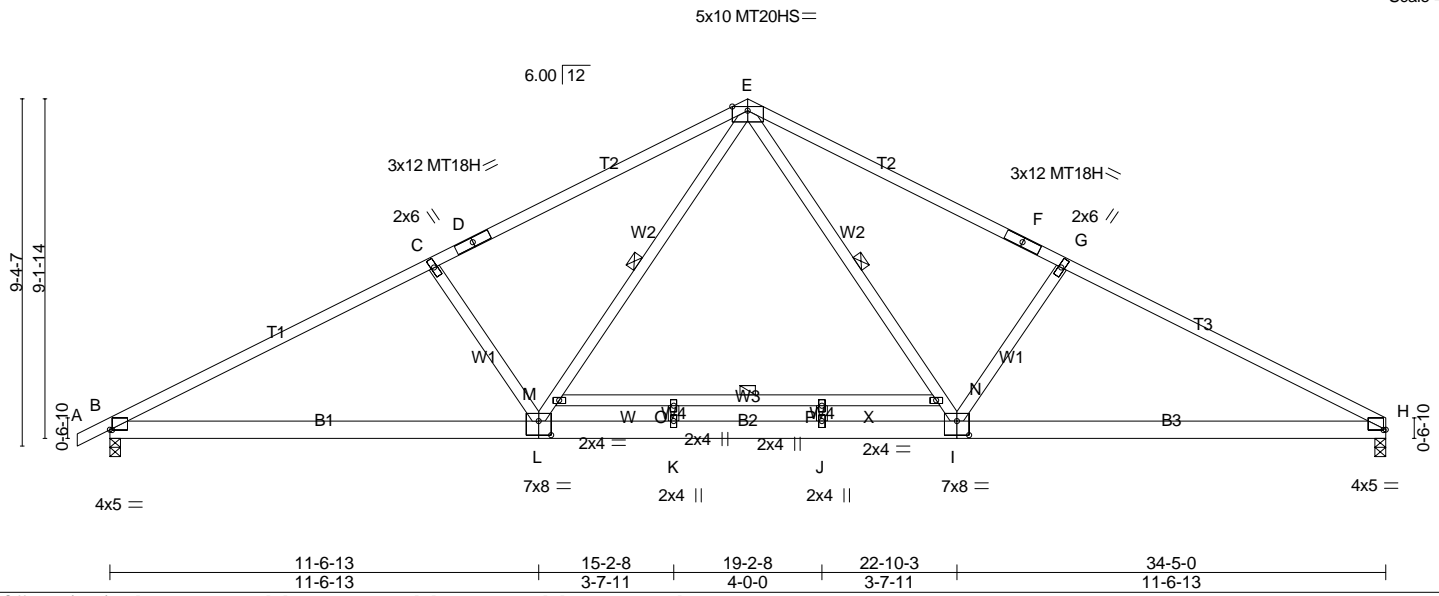

Plate Offsets (X,Y)-- [B:0-0-12,0-0-2], [H:0-0-12,0-0-2], [I:0-4-0,0-4-8], [L:0-4-0,0-4-8]

LOADING (psf)	SPACING-	CSI.	DEFL.	in (loc)	l/defl	L/d	PLATES	GRIP
TCLL 20.0	Plate Grip DOL 2-0-0	TC 0.97	Vert(LL) -0.30	J-K	>999	360	MT20	244/190
TCDL 10.0	Lumber DOL 1.15	BC 0.85	Vert(TL) -0.49	J-K	>839	240	MT20HS	187/143
BCLL 0.0 *	Rep Stress Incr NO	WB 0.51	Horz(TL) 0.07	H	n/a	n/a	MT18H	244/190
BCDL 10.0	Code IRC2009/TPI2007	(Matrix-S)	Wind(LL) 0.19	I-V	>999	240	Weight: 201 lb	FT = 20%

LUMBER-	BRACING-
TOP CHORD 2x4 SP No.2 *Except* T1,T3: 2x4 SP No.1	TOP CHORD Structural wood sheathing directly applied.
BOT CHORD 2x6 SP No.2	BOT CHORD Rigid ceiling directly applied.
WEBS 2x4 SP No.3 *Except* W3: 2x4 SP No.2	WEBS 1 Row at midpt E-I, E-L, M-N

MiTek recommends that Stabilizers and required cross bracing be installed during truss erection, in accordance with Stabilizer Installation guide.

REACTIONS. (lb/size) B=1430/0-3-8 (min. 0-1-11), H=1376/0-3-8 (min. 0-1-10)
Max Horz B=233(LC 8)
Max Uplift B=-581(LC 8), H=-507(LC 9)

FORCES. (lb) - Max. Comp./Max. Ten. - All forces 250 (lb) or less except when shown.
TOP CHORD B-C=-2395/2192, C-D=-2122/2101, D-E=-2000/2143, E-F=-2002/2146, F-G=-2124/2105, G-H=-2398/2195
BOT CHORD B-L=-1734/2053, K-L=-957/1459, J-K=-957/1459, I-J=-957/1459, H-I=-1738/2056
WEBS E-N=-738/911, I-N=-694/826, G-I=-508/869, L-M=-687/825, E-M=-732/910, C-L=-507/867

- NOTES-**
- 1) Unbalanced roof live loads have been considered for this design.
 - 2) Wind: ASCE 7-05; 130mph; TCDL=6.0psf; BCDL=6.0psf; h=25ft; Cat. II; Exp C; enclosed; MWFRS (low-rise) and C-C Exterior(2) zone; end vertical left and right exposed; C-C for members and forces & MWFRS for reactions shown; Lumber DOL=1.60 plate grip DOL=1.60
 - 3) This truss has been designed for basic load combinations, which include cases with reductions for multiple concurrent live loads.
 - 4) All plates are MT20 plates unless otherwise indicated.
 - 5) This truss has been designed for a 10.0 psf bottom chord live load nonconcurrent with any other live loads.
 - 6) * This truss has been designed for a live load of 20.0psf on the bottom chord in all areas where a rectangle 3-6-0 tall by 2-0-0 wide will fit between the bottom chord and any other members.
 - 7) Provide mechanical connection (by others) of truss to bearing plate capable of withstanding 100 lb uplift at joint(s) except (jt=lb) B=581, H=507.
 - 8) This truss is designed in accordance with the 2009 International Residential Code sections R502.11.1 and R802.10.2 and referenced standard ANSI/TPI 1.
 - 9) This truss design requires that a minimum of 7/16" structural wood sheathing be applied directly to the top chord and 1/2" gypsum sheetrock be applied directly to the bottom chord.

LOAD CASE(S) Standard
1) Dead + Roof Live (balanced): Lumber Increase=1.15, Plate Increase=1.15
Uniform Loads (plf)
Vert: A-E=-60, E-H=-60, Q-T=-20

Job	Truss	Truss Type	Qty	Ply	H&H-NC/Wayfare/
MASTER	A08	COMMON	4	1	

Builders FirstSource, N. Charleston, SC

Run: 7.640 s Apr 22 2016 Print: 7.640 s Apr 22 2016 MiTek Industries, Inc. Wed Jan 10 11:33:29 2018 Page 1
 ID:5gbe_Q0JNoiH4zfeQirvLHzQqXF-NnFj7wLDiMZW5lR.JouBqCpT5?knKqLiScyc4f2zwnaa

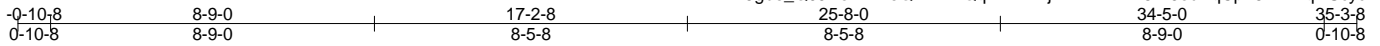

Scale = 1:62.2

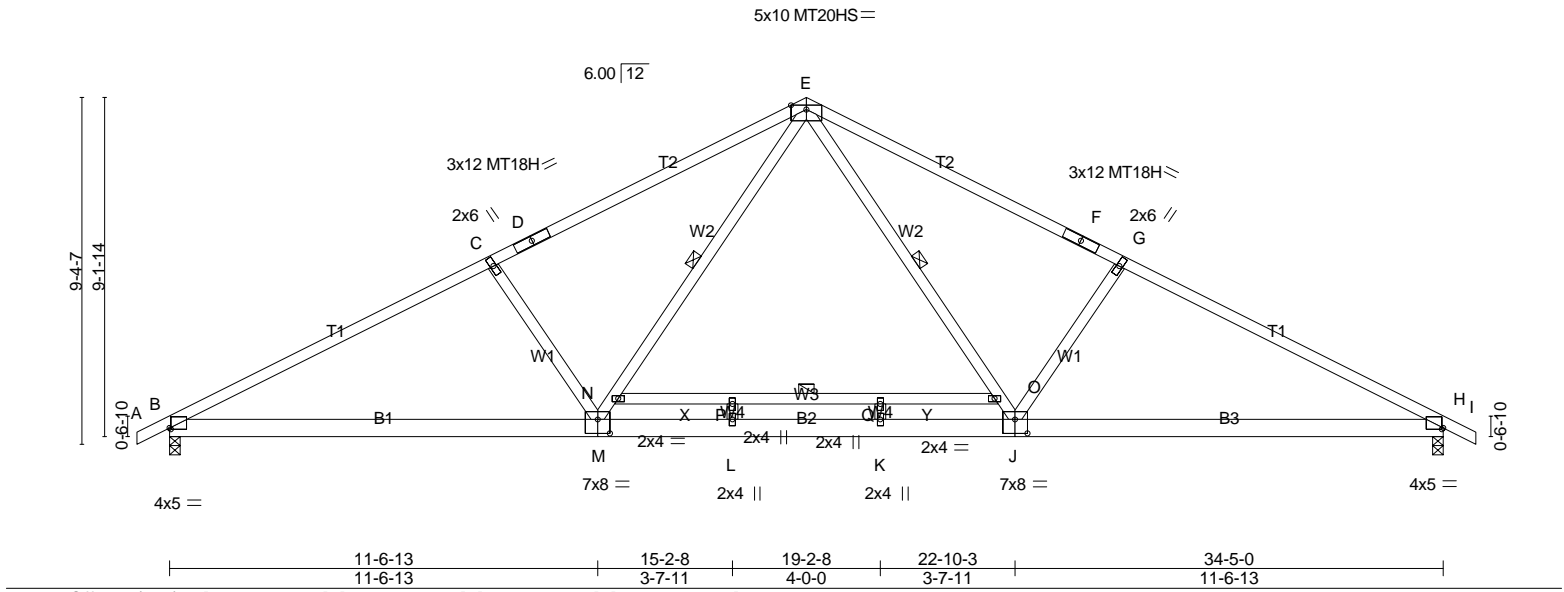

Plate Offsets (X,Y)-- [B:0-0-8,0-0-6], [H:0-0-8,0-0-6], [J:0-4-0,0-4-8], [M:0-4-0,0-4-8]					
LOADING (psf)	SPACING- 2-0-0	CSI.	DEFL. in (loc) l/defl L/d	PLATES	GRIP
TCLL 20.0	Plate Grip DOL 1.15	TC 0.97	Vert(LL) -0.30 K-L >999 360	MT20	244/190
TCDL 10.0	Lumber DOL 1.15	BC 0.85	Vert(TL) -0.49 K-L >837 240	MT20HS	187/143
BCLL 0.0 *	Rep Stress Incr NO	WB 0.51	Horz(TL) 0.07 H n/a n/a	MT18H	244/190
BCDL 10.0	Code IRC2009/TPI2007	(Matrix-S)	Wind(LL) 0.18 J-W >999 240		Weight: 203 lb FT = 20%

LUMBER-	BRACING-
TOP CHORD 2x4 SP No.2 *Except* T1: 2x4 SP No.1	TOP CHORD Structural wood sheathing directly applied.
BOT CHORD 2x6 SP No.2	BOT CHORD Rigid ceiling directly applied.
WEBS 2x4 SP No.3 *Except* W3: 2x4 SP No.2	WEBS 1 Row at midpt E-J, E-M, N-O

MiTek recommends that Stabilizers and required cross bracing be installed during truss erection, in accordance with Stabilizer Installation guide.

REACTIONS. (lb/size) B=1429/0-3-8 (min. 0-1-11), H=1429/0-3-8 (min. 0-1-11)
 Max Horz B=222(LC 8)
 Max Uplift B=-581(LC 8), H=-581(LC 9)

FORCES. (lb) - Max. Comp./Max. Ten. - All forces 250 (lb) or less except when shown.
 TOP CHORD B-C=-2394/2189, C-D=-2120/2098, D-E=-1998/2140, E-F=-1998/2140, F-G=-2120/2098,
 G-H=-2394/2189
 BOT CHORD B-M=-1691/2052, L-M=-917/1458, K-L=-917/1458, J-K=-917/1458, H-J=-1695/2052
 WEBS E-O=-733/910, J-O=-689/825, G-J=-507/867, M-N=-688/825, E-N=-733/910, C-M=-507/867

- NOTES-**
- 1) Unbalanced roof live loads have been considered for this design.
 - 2) Wind: ASCE 7-05; 130mph; TC DL=6.0psf; BC DL=6.0psf; h=25ft; Cat. II; Exp C; enclosed; MWFRS (low-rise) and C-C Exterior(2) zone; end vertical left and right exposed; C-C for members and forces & MWFRS for reactions shown; Lumber DOL=1.60 plate grip DOL=1.60
 - 3) This truss has been designed for basic load combinations, which include cases with reductions for multiple concurrent live loads.
 - 4) All plates are MT20 plates unless otherwise indicated.
 - 5) This truss has been designed for a 10.0 psf bottom chord live load nonconcurrent with any other live loads.
 - 6) * This truss has been designed for a live load of 20.0psf on the bottom chord in all areas where a rectangle 3-6-0 tall by 2-0-0 wide will fit between the bottom chord and any other members.
 - 7) Provide mechanical connection (by others) of truss to bearing plate capable of withstanding 100 lb uplift at joint(s) except (jt=lb) B=581, H=581.
 - 8) This truss is designed in accordance with the 2009 International Residential Code sections R502.11.1 and R802.10.2 and referenced standard ANSI/TPI 1.
 - 9) This truss design requires that a minimum of 7/16" structural wood sheathing be applied directly to the top chord and 1/2" gypsum sheetrock be applied directly to the bottom chord.

LOAD CASE(S) Standard
 1) Dead + Roof Live (balanced): Lumber Increase=1.15, Plate Increase=1.15
 Uniform Loads (plf)
 Vert: A-E=-60, E-I=-60, R-U=-20

Job	Truss	Truss Type	Qty	Ply	H&H-NC/Wayfare/
MASTER	A09	HIP	2	1	

Builders FirstSource, N. Charleston, SC

Run: 7.640 s Apr 22 2016 Print: 7.640 s Apr 22 2016 MiTek Industries, Inc. Wed Jan 10 11:33:29 2018 Page 1
 ID:5gbe_Q0JNoiH4zfeQirvLHzQqXF-NnFj7wLDiMZW5IRJouBqCpT6Pkn9qljScyc4f2zwnaa

0-10-8	7-9-8	15-3-8	19-1-8	26-7-8	34-5-0	35-3-8
0-10-8	7-9-8	7-6-0	3-10-0	7-6-0	7-9-8	0-10-8

Scale = 1:62.1

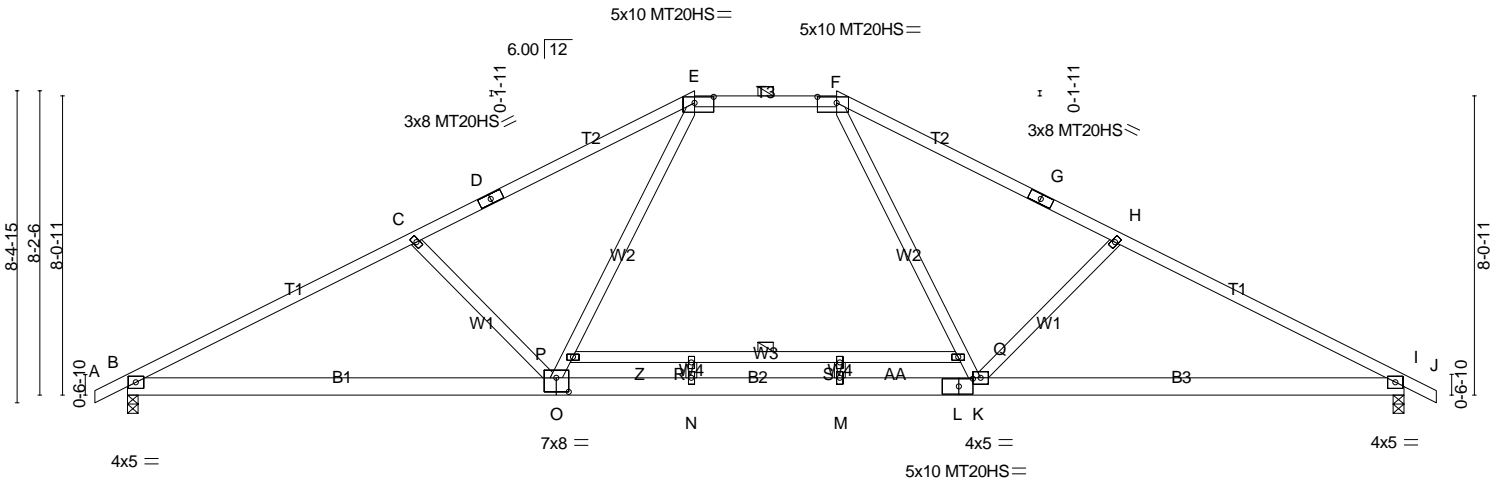

11-6-13	15-2-8	19-2-8	22-10-2	34-5-0
11-6-13	3-7-11	4-0-0	3-7-10	11-6-14

Plate Offsets (X,Y)-- [E:0-6-4,0-2-0], [F:0-6-4,0-2-0], [L:0-4-10,0-2-8], [O:0-4-0,0-4-8]

LOADING (psf)	SPACING-	CSI.	DEFL.	in (loc)	l/defl	L/d	PLATES	GRIP
TCLL 20.0	2-0-0	TC 0.94	Vert(LL) -0.33	O-V	>999	360	MT20	244/190
TCDL 10.0	Plate Grip DOL 1.15	BC 0.86	Vert(TL) -0.53	O-V	>784	240	MT20HS	187/143
BCLL 0.0 *	Lumber DOL 1.15	WB 0.70	Horz(TL) 0.07	I	n/a	n/a		
BCDL 10.0	Rep Stress Incr NO	(Matrix-S)	Wind(LL) 0.31	O-V	>999	240		
	Code IRC2009/TPI2007							Weight: 198 lb FT = 20%

LUMBER-	BRACING-
TOP CHORD 2x4 SP No.2 *Except* T1: 2x4 SP No.1	TOP CHORD Structural wood sheathing directly applied, except 2-0-0 oc purlins (4-5-0 max.): E-F.
BOT CHORD 2x6 SP No.2	BOT CHORD Rigid ceiling directly applied.
WEBS 2x4 SP No.3 *Except* W3: 2x4 SP No.2	WEBS 1 Row at midpt P-Q

MiTek recommends that Stabilizers and required cross bracing be installed during truss erection, in accordance with Stabilizer Installation guide.

REACTIONS. (lb/size) B=1429/0-3-8 (min. 0-1-11), I=1429/0-3-8 (min. 0-1-11)
 Max Horz B=199(LC 8)
 Max Uplift B=-564(LC 8), I=-564(LC 9)

FORCES. (lb) - Max. Comp./Max. Ten. - All forces 250 (lb) or less except when shown.
 TOP CHORD B-C=-2428/2215, C-D=-2100/1977, D-E=-1986/2011, E-F=-1514/1731, F-G=-1995/2022,
 G-H=-2109/1988, H-I=-2430/2214
 BOT CHORD B-O=-1739/2093, N-O=-982/1530, M-N=-982/1530, L-M=-982/1530, K-L=-982/1530,
 I-K=-1742/2095
 WEBS C-O=-507/803, O-P=-491/771, E-P=-497/810, F-Q=-507/809, K-Q=-501/767, H-K=-503/800

- NOTES-**
- 1) Unbalanced roof live loads have been considered for this design.
 - 2) Wind: ASCE 7-05; 130mph; TCDL=6.0psf; BCDL=6.0psf; h=25ft; Cat. II; Exp C; enclosed; MWFRS (low-rise) and C-C Exterior(2) zone; end vertical left and right exposed; C-C for members and forces & MWFRS for reactions shown; Lumber DOL=1.60 plate grip DOL=1.60
 - 3) This truss has been designed for basic load combinations, which include cases with reductions for multiple concurrent live loads.
 - 4) Provide adequate drainage to prevent water ponding.
 - 5) All plates are MT20 plates unless otherwise indicated.
 - 6) All plates are 2x4 MT20 unless otherwise indicated.
 - 7) This truss has been designed for a 10.0 psf bottom chord live load nonconcurrent with any other live loads.
 - 8) * This truss has been designed for a live load of 20.0psf on the bottom chord in all areas where a rectangle 3-6-0 tall by 2-0-0 wide will fit between the bottom chord and any other members.
 - 9) Provide mechanical connection (by others) of truss to bearing plate capable of withstanding 100 lb uplift at joint(s) except (jt=lb) B=564, I=564.
 - 10) This truss is designed in accordance with the 2009 International Residential Code sections R502.11.1 and R802.10.2 and referenced standard ANSI/TPI 1.
 - 11) This truss design requires that a minimum of 7/16" structural wood sheathing be applied directly to the top chord and 1/2" gypsum sheetrock be applied directly to the bottom chord.
 - 12) Graphical purlin representation does not depict the size or the orientation of the purlin along the top and/or bottom chord.

LOAD CASE(S) Standard
 1) Dead + Roof Live (balanced): Lumber Increase=1.15, Plate Increase=1.15

Job	Truss	Truss Type	Qty	Ply	H&H-NC/Wayfare/
MASTER	A09	HIP	2	1	Job Reference (optional)

Builders FirstSource, N. Charleston, SC

Run: 7.640 s Apr 22 2016 Print: 7.640 s Apr 22 2016 MiTek Industries, Inc. Wed Jan 10 11:33:30 2018 Page 2
ID:5gbe_Q0JNoiH4zfeQirvLHzQqXF-rzp5KGMrTghNjS0VMci3k00H986OZlybrLdBuzwnaZ

LOAD CASE(S) Standard

Uniform Loads (plf)

Vert: A-E=-60, E-F=-60, F-J=-60, T-W=-20

Job	Truss	Truss Type	Qty	Ply	H&H-NC/Wayfare/
MASTER	A10	HIP	2	1	

Builders FirstSource, N. Charleston, SC

Run: 7.640 s Apr 22 2016 Print: 7.640 s Apr 22 2016 MiTek Industries, Inc. Wed Jan 10 11:33:30 2018 Page 1
 ID:5gbe_Q0JNoiH4zfeQirvLHzQqXF-rzp5KGMrTghNjS0VMci3k00Hn858ZojbrclDbUzwnaZ

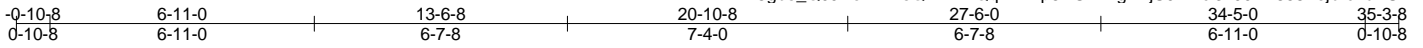

Scale = 1:60.3

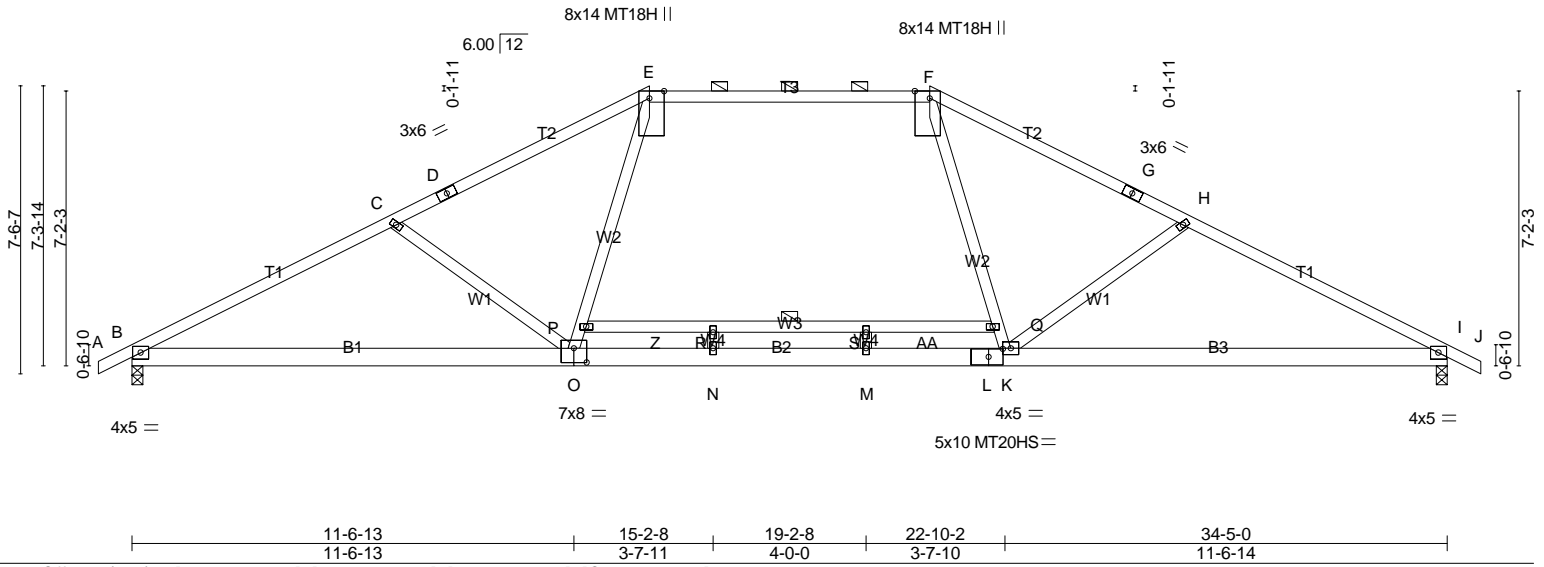

Plate Offsets (X,Y)-- [E:0-2-4,Edge], [F:0-2-4,Edge], [L:0-4-7,0-2-8], [O:0-4-0,0-4-8]

LOADING (psf)	SPACING-	CSI.	DEFL.	in (loc)	l/defl	L/d	PLATES	GRIP
TCLL 20.0	Plate Grip DOL 1.15	TC 0.90	Vert(LL) -0.52	O-V	>790	360	MT20	244/190
TCDL 10.0	Lumber DOL 1.15	BC 0.94	Vert(TL) -0.71	O-V	>580	240	MT20HS	187/143
BCLL 0.0 *	Rep Stress Incr NO	WB 0.46	Horz(TL) 0.08	I	n/a	n/a	MT18H	244/190
BCDL 10.0	Code IRC2009/TPI2007	(Matrix-S)	Wind(LL) 0.45	O-V	>913	240		Weight: 194 lb FT = 20%

LUMBER-
 TOP CHORD 2x4 SP No.2 *Except*
 T3: 2x4 SP No.1
 BOT CHORD 2x6 SP No.2
 WEBS 2x4 SP No.3 *Except*
 W3: 2x4 SP No.2

BRACING-
 TOP CHORD Structural wood sheathing directly applied, except
 2-0-0 oc purlins (3-7-7 max.): E-F.
 BOT CHORD Rigid ceiling directly applied.
 WEBS 1 Row at midpt P-Q

MiTek recommends that Stabilizers and required cross bracing be installed during truss erection, in accordance with Stabilizer Installation guide.

REACTIONS. (lb/size) B=1429/0-3-8 (min. 0-1-11), l=1429/0-3-8 (min. 0-1-11)
 Max Horz B=179(LC 8)
 Max Uplift B=-546(LC 8), l=-546(LC 9)

FORCES. (lb) - Max. Comp./Max. Ten. - All forces 250 (lb) or less except when shown.
 TOP CHORD B-C=-2449/2224, C-D=-2105/1905, D-E=-2018/1935, E-F=-1676/1791, F-G=-2023/1939,
 G-H=-2110/1909, H-I=-2450/2223
 BOT CHORD B-O=-1764/2118, N-O=-1107/1669, M-N=-1107/1669, L-M=-1107/1669, K-L=-1107/1669,
 I-K=-1767/2120
 WEBS C-O=-455/714, O-P=-302/701, E-P=-301/728, F-Q=-305/729, K-Q=-307/702, H-K=-452/712

- NOTES-**
- 1) Unbalanced roof live loads have been considered for this design.
 - 2) Wind: ASCE 7-05; 130mph; TCDL=6.0psf; BCDL=6.0psf; h=25ft; Cat. II; Exp C; enclosed; MWFRS (low-rise) and C-C Exterior(2) zone; end vertical left and right exposed; C-C for members and forces & MWFRS for reactions shown; Lumber DOL=1.60 plate grip DOL=1.60
 - 3) This truss has been designed for basic load combinations, which include cases with reductions for multiple concurrent live loads.
 - 4) Provide adequate drainage to prevent water ponding.
 - 5) All plates are MT20 plates unless otherwise indicated.
 - 6) All plates are 2x4 MT20 unless otherwise indicated.
 - 7) This truss has been designed for a 10.0 psf bottom chord live load nonconcurrent with any other live loads.
 - 8) * This truss has been designed for a live load of 20.0psf on the bottom chord in all areas where a rectangle 3-6-0 tall by 2-0-0 wide will fit between the bottom chord and any other members.
 - 9) Provide mechanical connection (by others) of truss to bearing plate capable of withstanding 100 lb uplift at joint(s) except (jt=lb) B=546, l=546.
 - 10) This truss is designed in accordance with the 2009 International Residential Code sections R502.11.1 and R802.10.2 and referenced standard ANSI/TPI 1.
 - 11) This truss design requires that a minimum of 7/16" structural wood sheathing be applied directly to the top chord and 1/2" gypsum sheetrock be applied directly to the bottom chord.
 - 12) Graphical purlin representation does not depict the size or the orientation of the purlin along the top and/or bottom chord.

LOAD CASE(S) Standard
 1) Dead + Roof Live (balanced): Lumber Increase=1.15, Plate Increase=1.15

Job	Truss	Truss Type	Qty	Ply	H&H-NC/Wayfare/
MASTER	A10	HIP	2	1	Job Reference (optional)

Builders FirstSource, N. Charleston, SC

Run: 7.640 s Apr 22 2016 Print: 7.640 s Apr 22 2016 MiTek Industries, Inc. Wed Jan 10 11:33:30 2018 Page 2
ID:5gbe_Q0JNoiH4zfeQirvLHzQqXF-rzp5KGMrTghNjS0VMci3k00Hn858ZojbrLdBuzwnaZ

LOAD CASE(S) Standard

Uniform Loads (plf)

Vert: A-E=-60, E-F=-60, F-J=-60, T-W=-20

Job	Truss	Truss Type	Qty	Ply	H&H-NC/Wayfare/
MASTER	A11	HIP	2	1	

Builders FirstSource, N. Charleston, SC

Run: 7.640 s Apr 22 2016 Print: 7.640 s Apr 22 2016 MiTek Industries, Inc. Wed Jan 10 11:33:31 2018 Page 1
 ID:5gbe_Q0JNoiH4zfeQirvLHzQqXF-J9NUYbMTEzpELcbhvJDIHEYSbXR_IJEI4G5BkwzwnaY

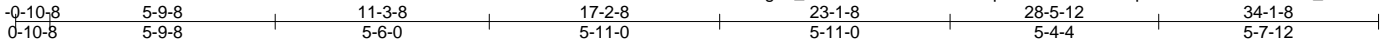

Scale = 1:59.2

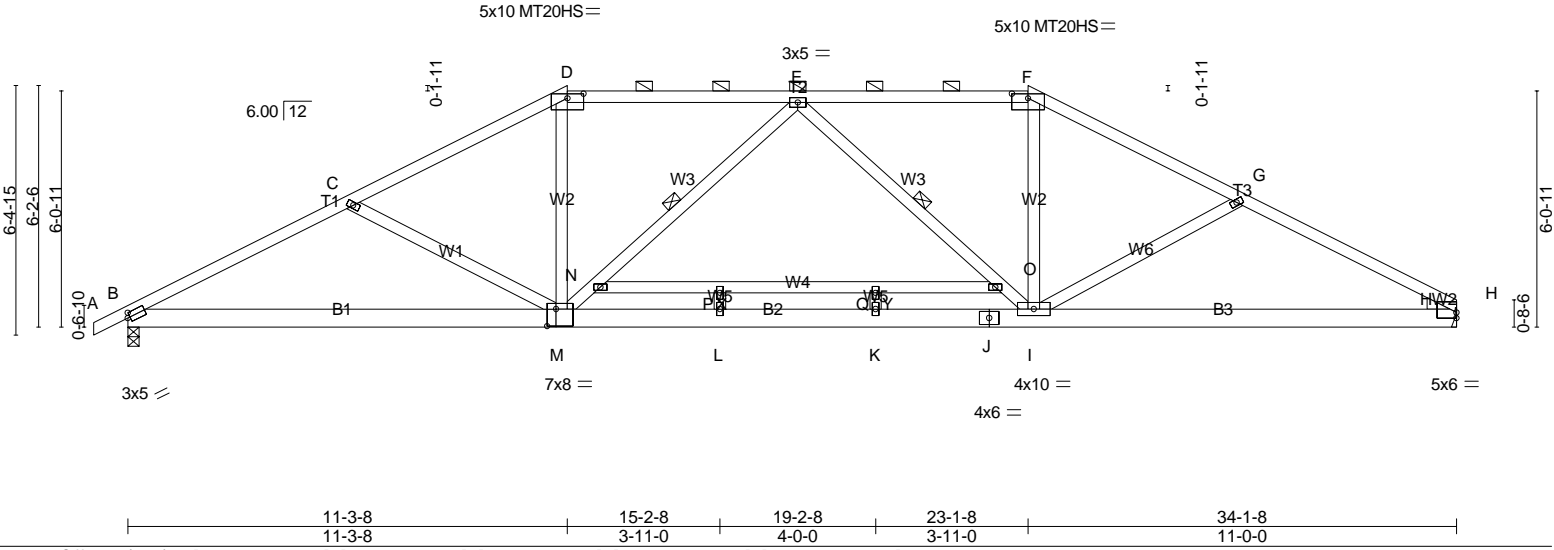

Plate Offsets (X,Y)-- [B:0-0-12,0-1-8], [D:0-5-0,0-1-7], [F:0-5-0,0-1-7], [H:0-0-0,0-1-12], [M:0-2-12,0-5-4]

LOADING (psf)	SPACING-	2-0-0	CSI.	DEFL.	in (loc)	l/defl	L/d	PLATES	GRIP	
TCLL 20.0	Plate Grip DOL	1.15	TC 0.90	Vert(LL)	-0.32	K-L	>999	360	MT20	244/190
TCDL 10.0	Lumber DOL	1.15	BC 0.90	Vert(TL)	-0.60	K-L	>678	240	MT20HS	187/143
BCLL 0.0 *	Rep Stress Incr	NO	WB 0.49	Horz(TL)	0.09	H	n/a	n/a		
BCDL 10.0	Code IRC2009/TPI2007		(Matrix-S)	Wind(LL)	0.22	K-L	>999	240		Weight: 211 lb FT = 20%

LUMBER-
 TOP CHORD 2x4 SP No.2
 BOT CHORD 2x6 SP No.2
 WEBS 2x4 SP No.3 *Except*
 W4: 2x4 SP No.2
 WEDGE
 Right: 2x4 SP No.3

BRACING-
 TOP CHORD Structural wood sheathing directly applied, except
 2-0-0 oc purlins (3-11-7 max.): D-F.
 BOT CHORD Rigid ceiling directly applied.
 WEBS 1 Row at midpt E-M, E-I

MiTek recommends that Stabilizers and required cross bracing be installed during truss erection, in accordance with Stabilizer Installation guide.

REACTIONS. (lb/size) H=1364/Mechanical, B=1418/0-3-8 (min. 0-1-11)
 Max Horz B=171(LC 8)
 Max Uplift H=-437(LC 9), B=-516(LC 8)

FORCES. (lb) - Max. Comp./Max. Ten. - All forces 250 (lb) or less except when shown.
 TOP CHORD B-C=-2479/2226, C-D=-2152/1903, D-E=-1839/1803, E-F=-1812/1776, F-G=-2099/1862,
 G-H=-2402/2157
 BOT CHORD B-M=-1845/2156, L-M=-1515/2023, K-L=-1515/2023, J-K=-1515/2023, I-J=-1515/2023,
 H-I=-1768/2073
 WEBS C-M=-337/619, D-M=-394/709, M-N=-395/328, E-N=-402/353, E-O=-434/392, I-O=-422/372,
 F-I=-377/685, G-I=-295/577

- NOTES-**
- 1) Unbalanced roof live loads have been considered for this design.
 - 2) Wind: ASCE 7-05; 130mph; TCDL=6.0psf; BCDL=6.0psf; h=25ft; Cat. II; Exp C; enclosed; MWFRS (low-rise) and C-C Exterior(2) zone; end vertical left exposed; C-C for members and forces & MWFRS for reactions shown; Lumber DOL=1.60 plate grip DOL=1.60
 - 3) This truss has been designed for basic load combinations, which include cases with reductions for multiple concurrent live loads.
 - 4) Provide adequate drainage to prevent water ponding.
 - 5) All plates are MT20 plates unless otherwise indicated.
 - 6) All plates are 2x4 MT20 unless otherwise indicated.
 - 7) This truss has been designed for a 10.0 psf bottom chord live load nonconcurrent with any other live loads.
 - 8) * This truss has been designed for a live load of 20.0psf on the bottom chord in all areas where a rectangle 3-6-0 tall by 2-0-0 wide will fit between the bottom chord and any other members.
 - 9) Refer to girder(s) for truss to truss connections.
 - 10) Provide mechanical connection (by others) of truss to bearing plate capable of withstanding 100 lb uplift at joint(s) except (jt=lb) H=437, B=516.
 - 11) This truss is designed in accordance with the 2009 International Residential Code sections R502.11.1 and R802.10.2 and referenced standard ANSI/TPI 1.
 - 12) This truss design requires that a minimum of 7/16" structural wood sheathing be applied directly to the top chord and 1/2" gypsum sheetrock be applied directly to the bottom chord.
 - 13) Graphical purlin representation does not depict the size or the orientation of the purlin along the top and/or bottom chord.

LOAD CASE(S) Standard

Job	Truss	Truss Type	Qty	Ply	H&H-NC/Wayfare/
MASTER	A11	HIP	2	1	Job Reference (optional)

Builders FirstSource, N. Charleston, SC

Run: 7.640 s Apr 22 2016 Print: 7.640 s Apr 22 2016 MiTek Industries, Inc. Wed Jan 10 11:33:31 2018 Page 2
ID:5gbe_Q0JNoiH4zfeQirvLHzQqXF-J9NUYbMTEzpELcbhvJDIHEYSbXR_IJEI4G5BkwzwnaY

LOAD CASE(S) Standard

1) Dead + Roof Live (balanced): Lumber Increase=1.15, Plate Increase=1.15

Uniform Loads (plf)

Vert: A-D=-60, D-F=-60, F-H=-60, R-U=-20

Job	Truss	Truss Type	Qty	Ply	H&H-NC/Wayfare/
MASTER	A12	HIP	2	1	

Builders FirstSource, N. Charleston, SC

Run: 7.640 s Apr 22 2016 Print: 7.640 s Apr 22 2016 MiTek Industries, Inc. Wed Jan 10 11:33:31 2018 Page 1
ID:5gbe_Q0JNoiH4zfeQirvLHzQqXF-J9NUYbMTEzpELcbhvJDIHEYtqXWVIEG4G5BkwzwnaY

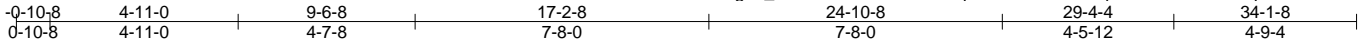

Scale = 1:60.2

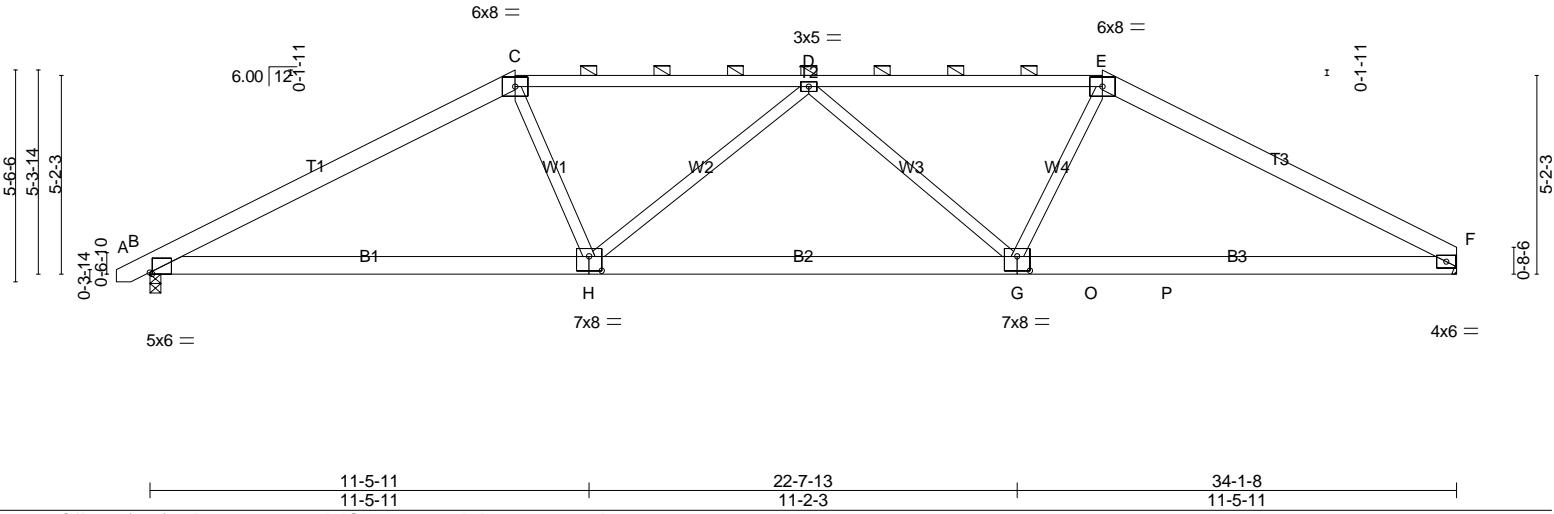

Plate Offsets (X,Y)-- [B:0-0-12,Edge], [G:0-4-0,0-4-8], [H:0-4-0,0-4-8]

LOADING (psf)	SPACING-	2-0-0	CSI.	DEFL.	in	(loc)	l/defl	L/d	PLATES	GRIP
TCLL 20.0	Plate Grip DOL	1.15	TC 0.89	Vert(LL)	-0.10	G-K	>999	360	MT20	244/190
TCDL 10.0	Lumber DOL	1.15	BC 0.61	Vert(TL)	-0.31	G-K	>999	240		
BCLL 0.0 *	Rep Stress Incr	YES	WB 0.50	Horz(TL)	0.08	F	n/a	n/a		
BCDL 10.0	Code IRC2009/TPI2007		(Matrix-S)	Wind(LL)	0.18	H-N	>999	240		
									Weight: 190 lb	FT = 20%

LUMBER-
 TOP CHORD 2x6 SP No.2 *Except*
 T2: 2x4 SP No.2
 BOT CHORD 2x6 SP No.2
 WEBS 2x4 SP No.3

BRACING-
 TOP CHORD Structural wood sheathing directly applied, except
 2-0-0 oc purlins (2-2-0 max.): C-E.
 BOT CHORD Rigid ceiling directly applied.

MiTek recommends that Stabilizers and required cross bracing be installed during truss erection, in accordance with Stabilizer Installation guide.

REACTIONS. (lb/size) F=1355/Mechanical, B=1416/0-3-8 (min. 0-1-11)
 Max Horz B=144(LC 8)
 Max Uplift F=-425(LC 6), B=-481(LC 8)

FORCES. (lb) - Max. Comp./Max. Ten. - All forces 250 (lb) or less except when shown.
 TOP CHORD B-C=-2292/1908, C-D=-2145/1968, D-E=-2161/1983, E-F=-2280/1911
 BOT CHORD B-H=-1450/1952, G-H=-1884/2433, G-O=-1452/1940, O-P=-1452/1940, F-P=-1452/1940
 WEBS C-H=-208/581, D-H=-471/466, D-G=-459/456, E-G=-214/588

- NOTES-**
- Unbalanced roof live loads have been considered for this design.
 - Wind: ASCE 7-05; 130mph; TCDL=6.0psf; BCDL=6.0psf; h=25ft; Cat. II; Exp C; enclosed; MWFRS (low-rise) and C-C Exterior(2) zone; end vertical left and right exposed; C-C for members and forces & MWFRS for reactions shown; Lumber DOL=1.60 plate grip DOL=1.60
 - This truss has been designed for basic load combinations, which include cases with reductions for multiple concurrent live loads.
 - Provide adequate drainage to prevent water ponding.
 - This truss has been designed for a 10.0 psf bottom chord live load nonconcurrent with any other live loads.
 - * This truss has been designed for a live load of 20.0psf on the bottom chord in all areas where a rectangle 3-6-0 tall by 2-0-0 wide will fit between the bottom chord and any other members, with BCDL = 10.0psf.
 - Refer to girder(s) for truss to truss connections.
 - Provide mechanical connection (by others) of truss to bearing plate capable of withstanding 100 lb uplift at joint(s) except (jt=lb) F=425, B=481.
 - This truss is designed in accordance with the 2009 International Residential Code sections R502.11.1 and R802.10.2 and referenced standard ANSI/TPI 1.
 - This truss design requires that a minimum of 7/16" structural wood sheathing be applied directly to the top chord and 1/2" gypsum sheetrock be applied directly to the bottom chord.
 - Graphical purlin representation does not depict the size or the orientation of the purlin along the top and/or bottom chord.

LOAD CASE(S) Standard

Job	Truss	Truss Type	Qty	Ply	H&H-NC/Wayfare/
MASTER	A13	HIP	2	1	
Builders FirstSource, N. Charleston, SC					
Run: 7.640 s Apr 22 2016 Print: 7.640 s Apr 22 2016 MiTek Industries, Inc. Wed Jan 10 11:33:32 2018 Page 1					
ID:5gbe_Q0JNoiH4zfeQirvLHzQqXF-nMxslxN5?Hx5zmAuT1XqR5gLxrw1feulwqkGMzwnaX					

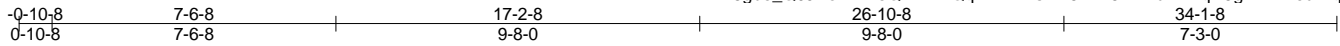

Scale = 1:61.2

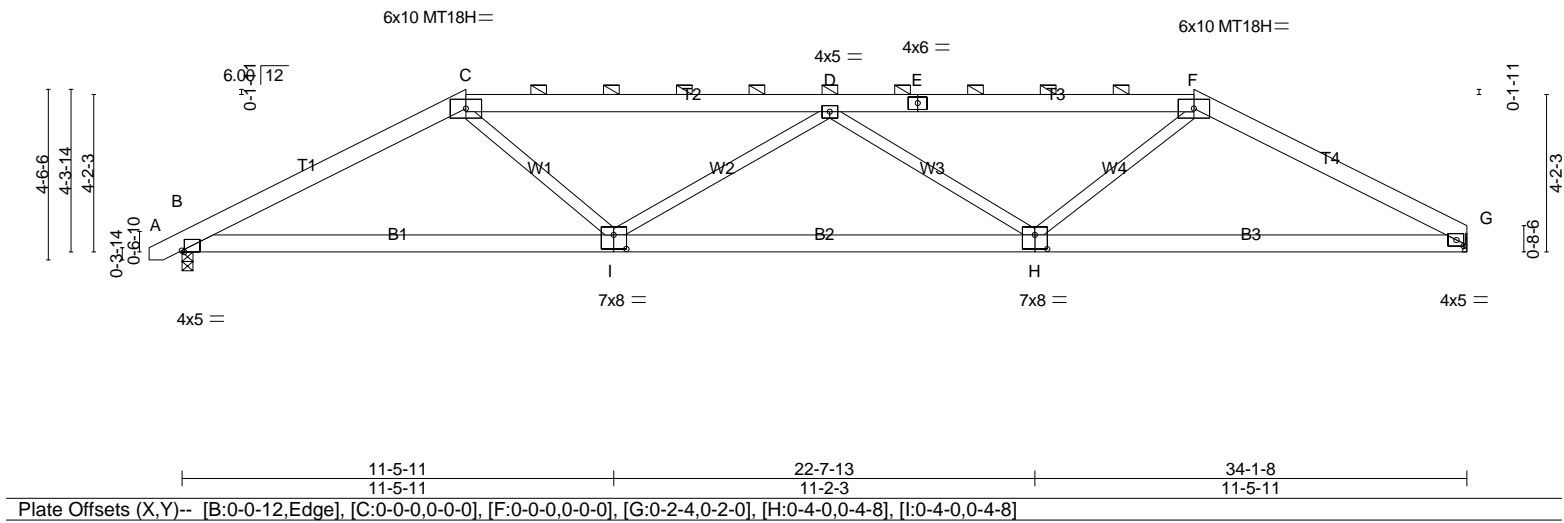

LOADING (psf)	SPACING-	2-0-0	CSI.	DEFL.	in (loc)	l/defl	L/d	PLATES	GRIP	
TCLL 20.0	Plate Grip DOL	1.15	TC 0.71	Vert(LL)	-0.14	H-I	>999	360	MT20	244/190
TCDL 10.0	Lumber DOL	1.15	BC 0.66	Vert(TL)	-0.40	H-I	>999	240	MT18H	244/190
BCLL 0.0 *	Rep Stress Incr	YES	WB 0.62	Horz(TL)	0.10	G	n/a	n/a		
BCDL 10.0	Code IRC2009/TPI2007		(Matrix-S)	Wind(LL)	0.20	H-I	>999	240		Weight: 201 lb FT = 20%

LUMBER-	BRACING-
TOP CHORD 2x6 SP No.2	TOP CHORD Structural wood sheathing directly applied, except
BOT CHORD 2x6 SP No.2	2-0-0 oc purlins (3-10-4 max.): C-F.
WEBS 2x4 SP No.3	BOT CHORD Rigid ceiling directly applied.
	MiTek recommends that Stabilizers and required cross bracing be installed during truss erection, in accordance with Stabilizer Installation guide.

REACTIONS. (lb/size) G=1358/Mechanical, B=1413/0-3-8 (min. 0-1-11)
Max Horz B=121(LC 8)
Max UpliftG=-474(LC 6), B=-487(LC 7)

FORCES. (lb) - Max. Comp./Max. Ten. - All forces 250 (lb) or less except when shown.
TOP CHORD B-C=-2432/2082, C-D=-2697/2311, D-E=-2713/2318, E-F=-2713/2320, F-G=-2409/2069
BOT CHORD B-I=-1678/2117, H-I=-2597/3199, G-H=-1661/2092
WEBS C-I=-406/842, D-I=-674/747, D-H=-661/746, F-H=-429/875

- NOTES-**
- 1) Unbalanced roof live loads have been considered for this design.
 - 2) Wind: ASCE 7-05; 130mph; TCDL=6.0psf; BCDL=6.0psf; h=25ft; Cat. II; Exp C; enclosed; MWFRS (low-rise) and C-C Exterior(2) zone; end vertical left and right exposed;C-C for members and forces & MWFRS for reactions shown; Lumber DOL=1.60 plate grip DOL=1.60
 - 3) This truss has been designed for basic load combinations, which include cases with reductions for multiple concurrent live loads.
 - 4) Provide adequate drainage to prevent water ponding.
 - 5) All plates are MT20 plates unless otherwise indicated.
 - 6) This truss has been designed for a 10.0 psf bottom chord live load nonconcurrent with any other live loads.
 - 7) * This truss has been designed for a live load of 20.0psf on the bottom chord in all areas where a rectangle 3-6-0 tall by 2-0-0 wide will fit between the bottom chord and any other members.
 - 8) Refer to girder(s) for truss connections.
 - 9) Provide mechanical connection (by others) of truss to bearing plate capable of withstanding 100 lb uplift at joint(s) except (jt=lb) G=474, B=487.
 - 10) This truss is designed in accordance with the 2009 International Residential Code sections R502.11.1 and R802.10.2 and referenced standard ANSI/TPI 1.
 - 11) This truss design requires that a minimum of 7/16" structural wood sheathing be applied directly to the top chord and 1/2" gypsum sheetrock be applied directly to the bottom chord.
 - 12) Graphical purlin representation does not depict the size or the orientation of the purlin along the top and/or bottom chord.

LOAD CASE(S) Standard

Job	Truss	Truss Type	Qty	Ply	H&H-NC/Wayfare/
MASTER	A14	HALF HIP GIRDER	2	2	Job Reference (optional)

Builders FirstSource, N. Charleston, SC

Run: 7.640 s Apr 22 2016 Print: 7.640 s Apr 22 2016 MITek Industries, Inc. Wed Jan 10 11:33:34 2018 Page 1
ID:5gbe_Q0JNoiH4zfeQirvLHzQqXF-jk3cAdPLXuCoC3KGBsn?vsA4ilVfVYOBmEJrKFzwnaV

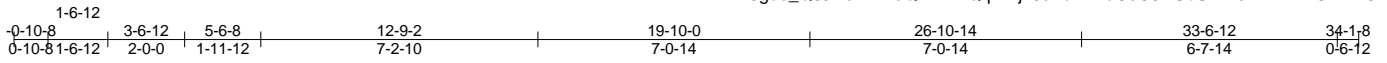

Scale = 1:60.0

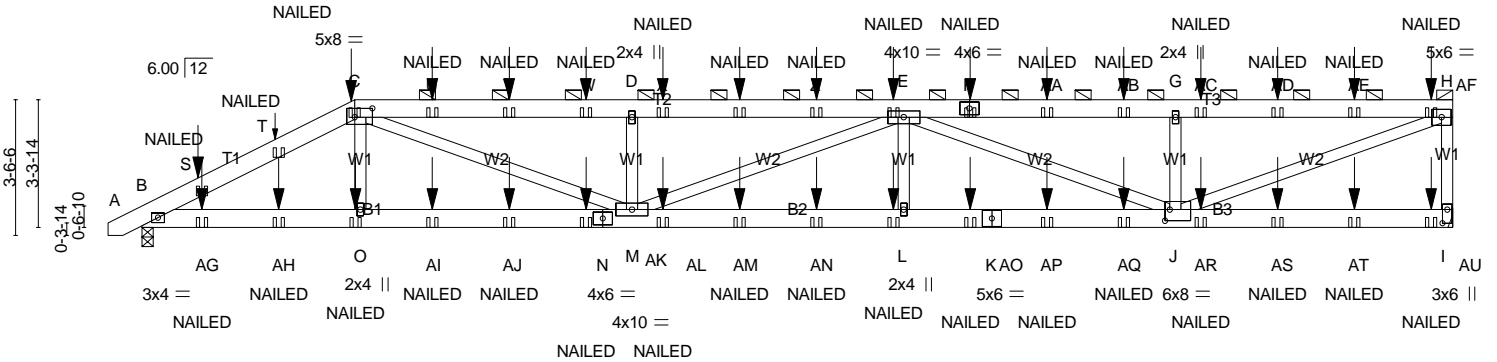

1-6-12	3-6-12	5-6-8	12-9-2	19-10-0	26-10-14	33-6-12	34-1-8
1-6-12	2-0-0	1-11-12	7-2-10	7-0-14	7-0-14	6-7-14	0-6-12

Plate Offsets (X,Y)-- [C:0-5-8,0-2-12], [I:0-4-4,0-1-8], [J:0-1-8,0-3-8]

LOADING (psf)	SPACING-	2-0-0	CSI.	DEFL.	in (loc)	l/defl	L/d	PLATES	GRIP
TCLL 20.0	Plate Grip DOL	1.15	TC 0.46	Vert(LL)	-0.23	L-M	>999	MT20	244/190
TCDL 10.0	Lumber DOL	1.15	BC 0.78	Vert(TL)	-0.58	L-M	>706		
BCLL 0.0 *	Rep Stress Incr	NO	WB 0.67	Horz(TL)	0.10	I	n/a		
BCDL 10.0	Code IRC2009/TPI2007		(Matrix-M)	Wind(LL)	0.41	L-M	>999		
								Weight: 449 lb	FT = 20%

LUMBER-	BRACING-
TOP CHORD 2x6 SP No.2	TOP CHORD Structural wood sheathing directly applied or 6-0-0 oc purlins, except end verticals, and 2-0-0 oc purlins (5-4-6 max.): C-H.
BOT CHORD 2x6 SP No.2	BOT CHORD Rigid ceiling directly applied or 7-8-0 oc bracing.
WEBS 2x4 SP No.2	

REACTIONS. (lb/size) I=2572/Mechanical, B=2517/0-3-8 (min. 0-1-8)
Max Horz B=202(LC 6)
Max Uplift=-1537(LC 5), B=-1403(LC 5)

FORCES. (lb) - Max. Comp./Max. Ten. - All forces 250 (lb) or less except when shown.
TOP CHORD B-S=-4643/2647, S-T=-4558/2622, C-T=-4497/2630, C-U=-7063/4209, U-V=-7063/4209, V-W=-7063/4209, D-W=-7063/4209, D-X=-7063/4209, X-Y=-7063/4209, Y-Z=-7063/4209, E-Z=-7063/4209, E-F=-5071/3022, F-AA=-5071/3022, AA-AB=-5071/3022, G-AB=-5071/3022, G-AC=-5071/3022, AC-AD=-5071/3022, AD-AE=-5071/3022, AE-AF=-5071/3022, H-AF=-5071/3022, H-I=-2422/1580
BOT CHORD B-AG=-2403/4067, AG-AH=-2403/4067, O-AH=-2403/4067, O-AI=-2400/4081, AI-AJ=-2400/4081, AJ-AK=-2400/4081, N-AK=-2400/4081, M-N=-2400/4081, M-AL=-4367/7328, AL-AM=-4367/7328, AM-AN=-4367/7328, L-AN=-4367/7328, L-AO=-4367/7328, K-AO=-4367/7328, K-AP=-4367/7328, AP-AQ=-4367/7328, J-AQ=-4367/7328
WEBS C-O=0/419, C-M=-1978/3208, D-M=-848/818, E-M=-286/189, E-L=0/427, E-J=-2436/1451, G-J=-859/830, H-J=-3196/5363

- NOTES-**
- 2-ply truss to be connected together with 10d (0.131"x3") nails as follows:
Top chords connected as follows: 2x6 - 2 rows staggered at 0-9-0 oc, 2x4 - 1 row at 0-9-0 oc.
Bottom chords connected as follows: 2x6 - 2 rows staggered at 0-9-0 oc.
Webs connected as follows: 2x4 - 1 row at 0-9-0 oc.
 - All loads are considered equally applied to all plies, except if noted as front (F) or back (B) face in the LOAD CASE(S) section. Ply to ply connections have been provided to distribute only loads noted as (F) or (B), unless otherwise indicated.
 - Wind: ASCE 7-05; 130mph; TCDL=6.0psf; BCDL=6.0psf; h=25ft; Cat. II; Exp C; enclosed; MWFRS (low-rise); end vertical left exposed; Lumber DOL=1.60 plate grip DOL=1.60
 - This truss has been designed for basic load combinations, which include cases with reductions for multiple concurrent live loads.
 - Provide adequate drainage to prevent water ponding.
 - This truss has been designed for a 10.0 psf bottom chord live load nonconcurrent with any other live loads.
 - * This truss has been designed for a live load of 20.0psf on the bottom chord in all areas where a rectangle 3-6-0 tall by 2-0-0 wide will fit between the bottom chord and any other members.
 - Refer to girder(s) for truss to truss connections.
 - Provide mechanical connection (by others) of truss to bearing plate capable of withstanding 100 lb uplift at joint(s) except (jt=lb) I=1537, B=1403.
 - This truss is designed in accordance with the 2009 International Residential Code sections R502.11.1 and R802.10.2 and referenced standard ANSI/TPI 1.
 - "Semi-rigid pitchbreaks including heels" Member end fixity model was used in the analysis and design of this truss.
 - Graphical purlin representation does not depict the size or the orientation of the purlin along the top and/or bottom chord.

Continued on page 2

Job	Truss	Truss Type	Qty	Ply	H&H-NC/Wayfare/
MASTER	A14	HALF HIP GIRDER	2	2	Job Reference (optional)

Builders FirstSource, N. Charleston, SC

Run: 7.640 s Apr 22 2016 Print: 7.640 s Apr 22 2016 MiTek Industries, Inc. Wed Jan 10 11:33:34 2018 Page 2
ID:5gbe_Q0JNoiH4zfeQirvLHzQqXF-jk3cAdPLXuCoC3KGBsn?vsA4ilVfVYOBMERkKFzwnaV

NOTES-

13) "NAILED" indicates 3-10d (0.148"x3") or 3-12d (0.148"x3.25") toe-nails. For more details refer to MiTek's ST-TOENAIL Detail.

LOAD CASE(S) Standard

1) Dead + Roof Live (balanced): Lumber Increase=1.15, Plate Increase=1.15

Uniform Loads (plf)

Vert: A-C=-60, C-H=-60, I-P=-20

Concentrated Loads (lb)

Vert: C=-106(B) F=-106(B) O=-30(B) L=-30(B) E=-106(B) S=-69(B) U=-106(B) V=-106(B) W=-106(B) X=-106(B) Y=-106(B) Z=-106(B) AA=-106(B) AB=-106(B)
AC=-106(B) AD=-106(B) AE=-106(B) AF=-124(B) AG=-53(B) AH=-136(B) AI=-30(B) AJ=-30(B) AK=-30(B) AL=-30(B) AM=-30(B) AN=-30(B) AO=-30(B) AP=-30(B)
AQ=-30(B) AR=-30(B) AS=-30(B) AT=-30(B) AU=-36(B)

Job	Truss	Truss Type	Qty	Ply	H&H-NC/Wayfare/
MASTER	B01	GABLE	1	1	Job Reference (optional)

Builders FirstSource, N. Charleston, SC

Run: 7.640 s Apr 22 2016 Print: 7.640 s Apr 22 2016 MiTek Industries, Inc. Wed Jan 10 11:33:35 2018 Page 1
ID:5gbe_Q0JNoiH4zfeQirvLHzQqXF-Cxc_NzQzICKfqDvT89IER4jKf904E8MK?u3OthzwnaU

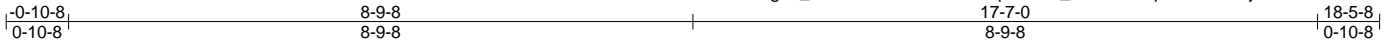

Scale = 1:32.4

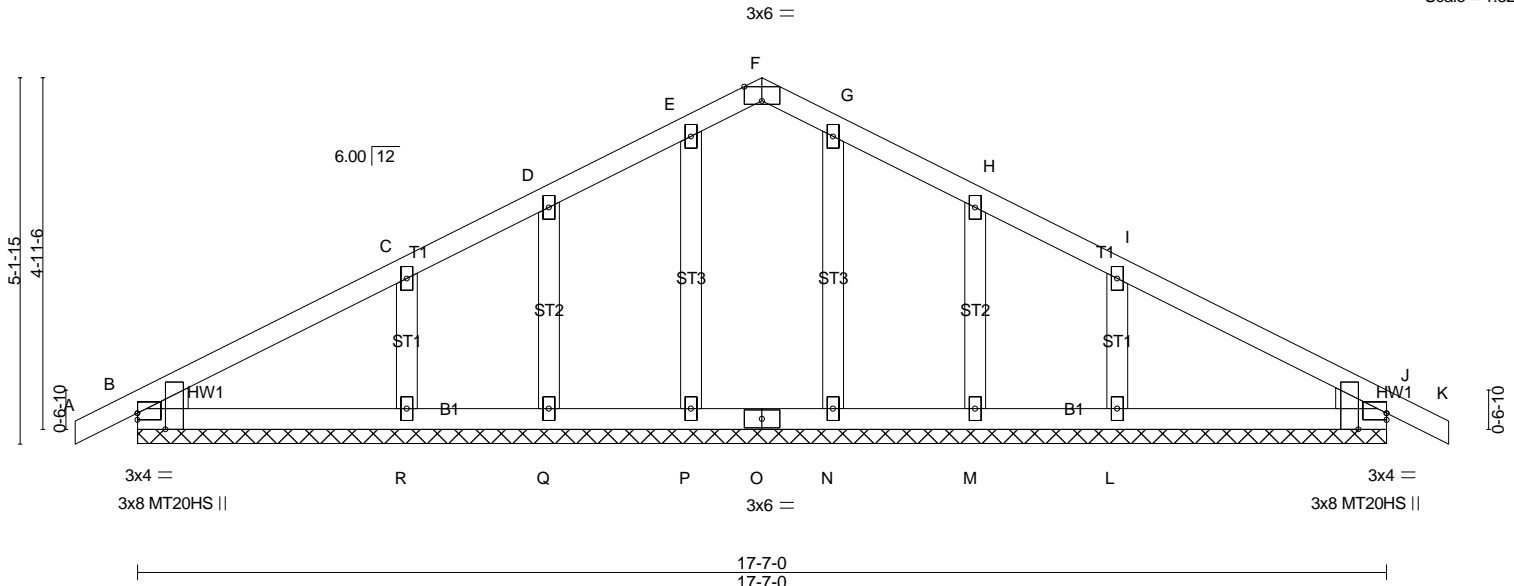

Plate Offsets (X,Y)-- [B:0-2-11,Edge], [B:0-0-0,0-1-2], [F:0-3-0,Edge], [J:0-0-0,0-1-2], [J:0-2-11,Edge]

LOADING (psf)	SPACING-	2-0-0	CSI.	DEFL.	in (loc)	l/defl	L/d	PLATES	GRIP
TCLL 20.0	Plate Grip DOL	1.15	TC 0.19	Vert(LL)	0.00	K	n/r	MT20	244/190
TCDL 10.0	Lumber DOL	1.15	BC 0.12	Vert(TL)	0.01	K	n/r	MT20HS	187/143
BCLL 0.0 *	Rep Stress Incr	YES	WB 0.11	Horz(TL)	0.00	J	n/a		
BCDL 10.0	Code IRC2009/TPI2007		(Matrix)						
								Weight: 86 lb	FT = 20%

LUMBER-
TOP CHORD 2x4 SP No.2
BOT CHORD 2x4 SP No.2
OTHERS 2x4 SP No.3
WEDGE
Left: 2x4 SP No.3, Right: 2x4 SP No.3

BRACING-
TOP CHORD Structural wood sheathing directly applied or 6-0-0 oc purlins.
BOT CHORD Rigid ceiling directly applied or 10-0-0 oc bracing.

MiTek recommends that Stabilizers and required cross bracing be installed during truss erection, in accordance with Stabilizer Installation guide.

REACTIONS. All bearings 17-7-0.
(lb) - Max Horz B=117(LC 8)
Max Uplift All uplift 100 lb or less at joint(s) B, P, Q, N, M, J except R=-193(LC 8), L=-190(LC 9)
Max Grav All reactions 250 lb or less at joint(s) B, P, Q, N, M, J except R=295(LC 13), L=295(LC 14)

FORCES. (lb) - Max. Comp./Max. Ten. - All forces 250 (lb) or less except when shown.
WEBS C-R=-210/383, I-L=-210/384

- NOTES-**
- Unbalanced roof live loads have been considered for this design.
 - Wind: ASCE 7-05; 130mph; TC DL=6.0psf; BC DL=6.0psf; h=25ft; Cat. II; Exp C; enclosed; MWFRS (low-rise) and C-C Exterior(2) zone; end vertical left and right exposed; C-C for members and forces & MWFRS for reactions shown; Lumber DOL=1.60 plate grip DOL=1.60
 - Truss designed for wind loads in the plane of the truss only. For studs exposed to wind (normal to the face), see Standard Industry Gable End Details as applicable, or consult qualified building designer as per ANSI/TPI 1.
 - This truss has been designed for basic load combinations, which include cases with reductions for multiple concurrent live loads.
 - All plates are MT20 plates unless otherwise indicated.
 - All plates are 2x4 MT20 unless otherwise indicated.
 - Gable requires continuous bottom chord bearing.
 - Gable studs spaced at 2-0-0 oc.
 - This truss has been designed for a 10.0 psf bottom chord live load nonconcurrent with any other live loads.
 - * This truss has been designed for a live load of 20.0psf on the bottom chord in all areas where a rectangle 3-6-0 tall by 2-0-0 wide will fit between the bottom chord and any other members.
 - Provide mechanical connection (by others) of truss to bearing plate capable of withstanding 100 lb uplift at joint(s) B, P, Q, N, M, J except (jt=lb) R=193, L=190.
 - This truss is designed in accordance with the 2009 International Residential Code sections R502.11.1 and R802.10.2 and referenced standard ANSI/TPI 1.
 - "Semi-rigid pitchbreaks including heels" Member end fixity model was used in the analysis and design of this truss.

LOAD CASE(S) Standard

Job	Truss	Truss Type	Qty	Ply	H&H-NC/Wayfare/
MASTER	B02	COMMON	1	1	Job Reference (optional)

Builders FirstSource, N. Charleston, SC

Run: 7.640 s Apr 22 2016 Print: 7.640 s Apr 22 2016 MiTek Industries, Inc. Wed Jan 10 11:33:35 2018 Page 1
ID:5gbe_Q0JNoiH4zfeQirvLHzQqXF-Cxc_NzQzICKfqDvT89IER4jF19tvE70K?u3OthzwnaU

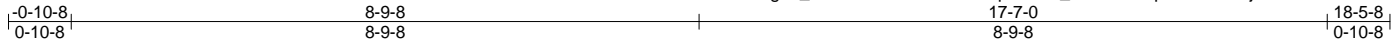

Scale: 3/8"=1'

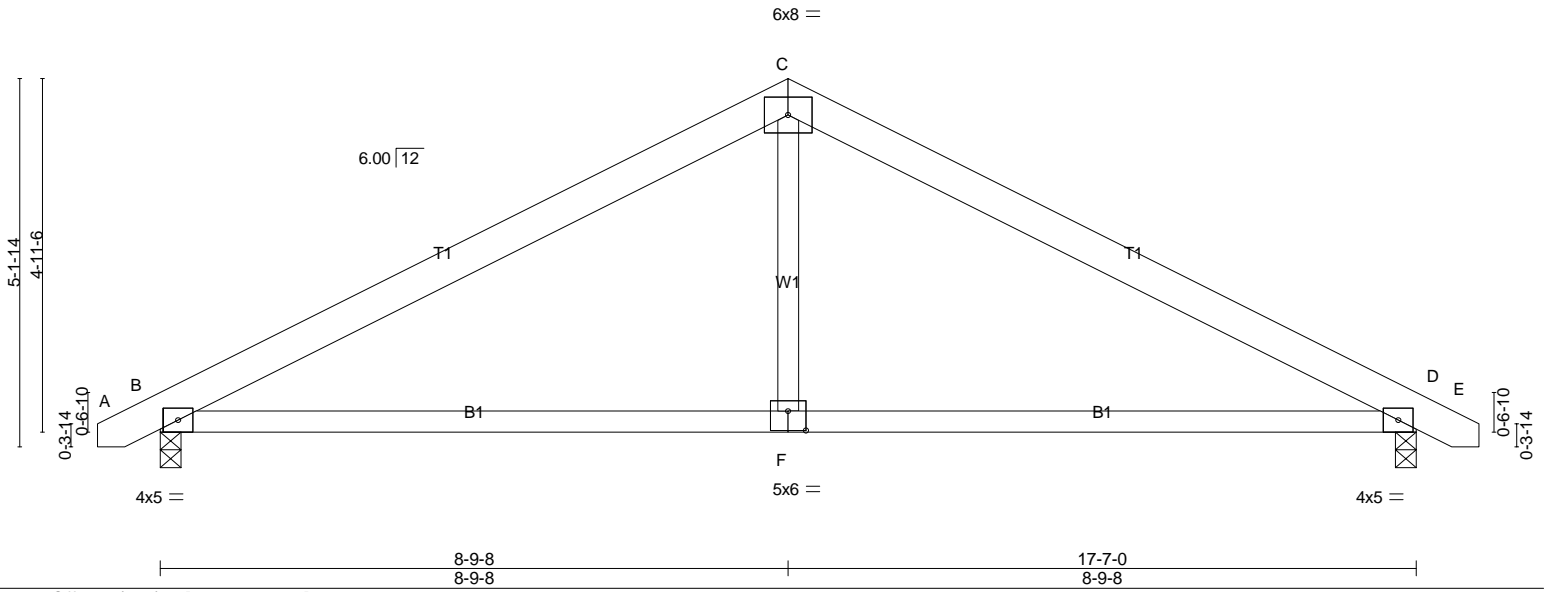

Plate Offsets (X,Y)-- [F:0-3-0,0-3-4]

LOADING (psf)	SPACING-	2-0-0	CSI.	DEFL.	in	(loc)	l/defl	L/d	PLATES	GRIP
TCLL 20.0	Plate Grip DOL	1.15	TC 0.49	Vert(LL)	-0.08	F-L	>999	360	MT20	244/190
TCDL 10.0	Lumber DOL	1.15	BC 0.65	Vert(TL)	-0.22	F-L	>952	240		
BCLL 0.0 *	Rep Stress Incr	YES	WB 0.14	Horz(TL)	0.02	D	n/a	n/a		
BCDL 10.0	Code IRC2009/TPI2007		(Matrix-S)	Wind(LL)	0.10	F-I	>999	240		
									Weight: 83 lb	FT = 20%

LUMBER-
 TOP CHORD 2x6 SP No.2
 BOT CHORD 2x4 SP No.2
 WEBS 2x4 SP No.3

BRACING-
 TOP CHORD Structural wood sheathing directly applied.
 BOT CHORD Rigid ceiling directly applied.

MiTek recommends that Stabilizers and required cross bracing be installed during truss erection, in accordance with Stabilizer Installation guide.

REACTIONS. (lb/size) B=744/0-3-8 (min. 0-1-8), D=744/0-3-8 (min. 0-1-8)
 Max Horz B=122(LC 8)
 Max Uplift B=-317(LC 8), D=-317(LC 9)

FORCES. (lb) - Max. Comp./Max. Ten. - All forces 250 (lb) or less except when shown.
 TOP CHORD B-C=-954/849, C-D=-954/849
 BOT CHORD B-F=-512/792, D-F=-512/792
 WEBS C-F=0/359

- NOTES-**
- 1) Unbalanced roof live loads have been considered for this design.
 - 2) Wind: ASCE 7-05; 130mph; TC DL=6.0psf; BC DL=6.0psf; h=25ft; Cat. II; Exp C; enclosed; MWFRS (low-rise) and C-C Exterior(2) zone; end vertical left and right exposed; C-C for members and forces & MWFRS for reactions shown; Lumber DOL=1.60 plate grip DOL=1.60
 - 3) This truss has been designed for basic load combinations, which include cases with reductions for multiple concurrent live loads.
 - 4) This truss has been designed for a 10.0 psf bottom chord live load nonconcurrent with any other live loads.
 - 5) * This truss has been designed for a live load of 20.0psf on the bottom chord in all areas where a rectangle 3-6-0 tall by 2-0-0 wide will fit between the bottom chord and any other members.
 - 6) Provide mechanical connection (by others) of truss to bearing plate capable of withstanding 100 lb uplift at joint(s) except (jt=lb) B=317, D=317.
 - 7) This truss is designed in accordance with the 2009 International Residential Code sections R502.11.1 and R802.10.2 and referenced standard ANSI/TPI 1.
 - 8) This truss design requires that a minimum of 7/16" structural wood sheathing be applied directly to the top chord and 1/2" gypsum sheetrock be applied directly to the bottom chord.

LOAD CASE(S) Standard

Job	Truss	Truss Type	Qty	Ply	H&H-NC/Wayfare/
MASTER	B03	COMMON GIRDER	1	2	Job Reference (optional)

Builders FirstSource, N. Charleston, SC

Run: 7.640 s Apr 22 2016 Print: 7.640 s Apr 22 2016 MiTek Industries, Inc. Wed Jan 10 11:33:36 2018 Page 1
ID:5gbe_Q0JNoiH4zfeQirvLHzQqXF-g7AMbJQc3WSWRNTfispT_HGQyYckzQJUDYoyP8zwnaT

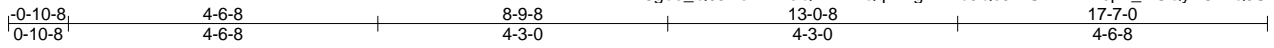

5x6 ||

Scale = 1:33.8

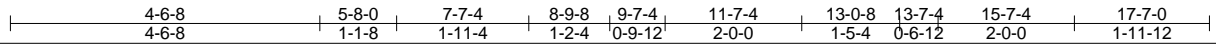
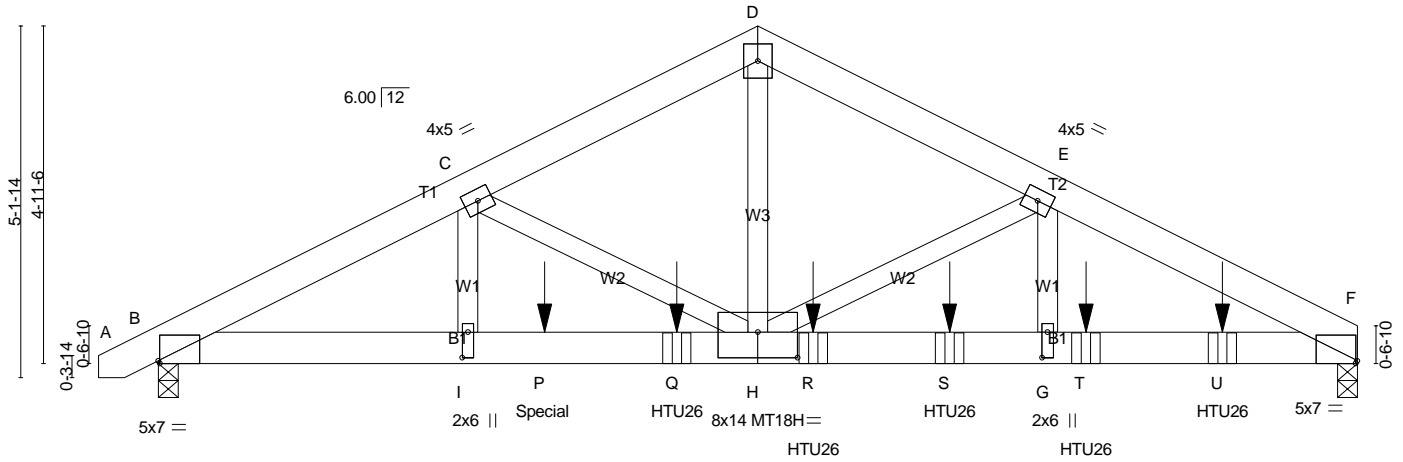

Plate Offsets (X,Y)-- [B:0-0-4,Edge], [F:0-0-4,Edge], [G:0-4-8,0-1-0], [H:0-7-0,0-4-8], [I:0-4-8,0-1-0]

LOADING (psf)	SPACING-	CSI.	DEFL.	in (loc)	l/defl	L/d	PLATES	GRIP
TCLL 20.0	Plate Grip DOL 1.15	TC 0.41	Vert(LL) -0.11	H-I	>999	360	MT20	244/190
TCDL 10.0	Lumber DOL 1.15	BC 0.74	Vert(TL) -0.27	H-I	>788	240	MT18H	244/190
BCLL 0.0 *	Rep Stress Incr NO	WB 0.77	Horz(TL) 0.07	F	n/a	n/a		
BCDL 10.0	Code IRC2009/TPI2007	(Matrix-M)	Wind(LL) 0.17	H-I	>999	240		Weight: 230 lb FT = 20%

LUMBER-
 TOP CHORD 2x6 SP No.2
 BOT CHORD 2x6 SP DSS
 WEBS 2x4 SP No.2

BRACING-
 TOP CHORD Structural wood sheathing directly applied or 4-5-11 oc purlins.
 BOT CHORD Rigid ceiling directly applied or 8-10-3 oc bracing.

REACTIONS. (lb/size) F=6001/0-3-8 (req. 0-3-9), B=4771/0-3-8 (min. 0-2-13)
 Max Horz B=130(LC 17)
 Max Uplift F=-2399(LC 7), B=-2248(LC 6)

FORCES. (lb) - Max. Comp./Max. Ten. - All forces 250 (lb) or less except when shown.
 TOP CHORD B-C=-9788/4605, C-D=-7603/3321, D-E=-7612/3332, E-F=-10517/4222
 BOT CHORD B-I=-4082/8615, I-P=-4082/8615, P-Q=-4082/8615, H-Q=-4082/8615, H-R=-3693/9370, R-S=-3693/9370, G-S=-3693/9370,
 G-T=-3693/9370, T-U=-3693/9370, F-U=-3693/9370
 WEBS D-H=-2713/6302, E-H=-2943/1060, E-G=-743/2564, C-H=-2082/1395, C-I=-1207/2051

- NOTES-**
- 2-ply truss to be connected together with 10d (0.131"x3") nails as follows:
 Top chords connected as follows: 2x6 - 2 rows staggered at 0-9-0 oc.
 Bottom chords connected as follows: 2x6 - 2 rows staggered at 0-4-0 oc.
 Webs connected as follows: 2x4 - 1 row at 0-9-0 oc.
 - All loads are considered equally applied to all plies, except if noted as front (F) or back (B) face in the LOAD CASE(S) section. Ply to ply connections have been provided to distribute only loads noted as (F) or (B), unless otherwise indicated.
 - Unbalanced roof live loads have been considered for this design.
 - Wind: ASCE 7-05; 130mph; TCDL=6.0psf; BCDL=6.0psf; h=25ft; Cat. II; Exp C; enclosed; MWFRS (low-rise); end vertical left and right exposed; Lumber DOL=1.60 plate grip DOL=1.60
 - This truss has been designed for basic load combinations, which include cases with reductions for multiple concurrent live loads.
 - All plates are MT20 plates unless otherwise indicated.
 - This truss has been designed for a 10.0 psf bottom chord live load nonconcurrent with any other live loads.
 - * This truss has been designed for a live load of 20.0psf on the bottom chord in all areas where a rectangle 3-6-0 tall by 2-0-0 wide will fit between the bottom chord and any other members.
 - WARNING: Required bearing size at joint(s) F greater than input bearing size.
 - Provide mechanical connection (by others) of truss to bearing plate capable of withstanding 100 lb uplift at joint(s) except (jt=lb) F=2399, B=2248.
 - This truss is designed in accordance with the 2009 International Residential Code sections R502.11.1 and R802.10.2 and referenced standard ANSI/TPI 1.
 - "Semi-rigid pitchbreaks including heels" Member end fixity model was used in the analysis and design of this truss.
 - Use Simpson Strong-Tie HTU26 (20-10d Girder, 11-10dx1 1/2 Truss, Single Ply Girder) or equivalent spaced at 2-0-0 oc max. starting at 7-7-4 from the left end to 15-7-4 to connect truss(es) A02 (1 ply 2x4 SP), A03 (1 ply 2x6 SP), A04 (1 ply 2x6 SP), A05 (1 ply 2x6 SP), A06 (1 ply 2x6 SP) to back face of bottom chord.
 - Fill all nail holes where hanger is in contact with lumber.
 - Hanger(s) or other connection device(s) shall be provided sufficient to support concentrated load(s) 2551 lb down and 1549 lb up at 5-8-0 on bottom chord. The design/selection of such connection device(s) is the responsibility of others.

LOAD CASE(S) Standard

Job	Truss	Truss Type	Qty	Ply	H&H-NC/Wayfare/
MASTER	B03	COMMON GIRDER	1	2	Job Reference (optional)

Builders FirstSource, N. Charleston, SC

Run: 7.640 s Apr 22 2016 Print: 7.640 s Apr 22 2016 MiTek Industries, Inc. Wed Jan 10 11:33:36 2018 Page 2
 ID:5gbe_Q0JNoiH4zfeQirvLHzQqXF-g7AMbJQc3WSWRNTfispT_HGQyYckzQJUDYoyP8zwnaT

LOAD CASE(S) Standard

1) Dead + Roof Live (balanced): Lumber Increase=1.15, Plate Increase=1.15

Uniform Loads (plf)

Vert: A-D=-60, D-F=-60, J-M=-20

Concentrated Loads (lb)

Vert: P=-2551(B) Q=-1350(B) R=-1356(B) S=-1356(B) T=-1356(B) U=-1356(B)

Job	Truss	Truss Type	Qty	Ply	H&H-NC/Wayfare/
MASTER	C01	COMMON SUPPORTED GAB	2	1	Job Reference (optional)

Builders FirstSource, N. Charleston, SC

Run: 7.640 s Apr 22 2016 Print: 7.640 s Apr 22 2016 MiTek Industries, Inc. Wed Jan 10 11:33:36 2018 Page 1
ID:5gbe_Q0JNoiH4zfeQirvLHzQqXF-g7AMBJQc3WSWRNTfispT_HGSyYL7zaBUDYoyP8zwnaT

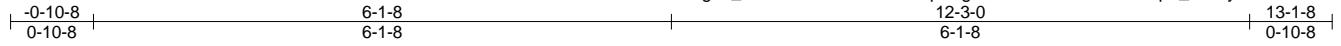

4x5 =

Scale = 1:24.4

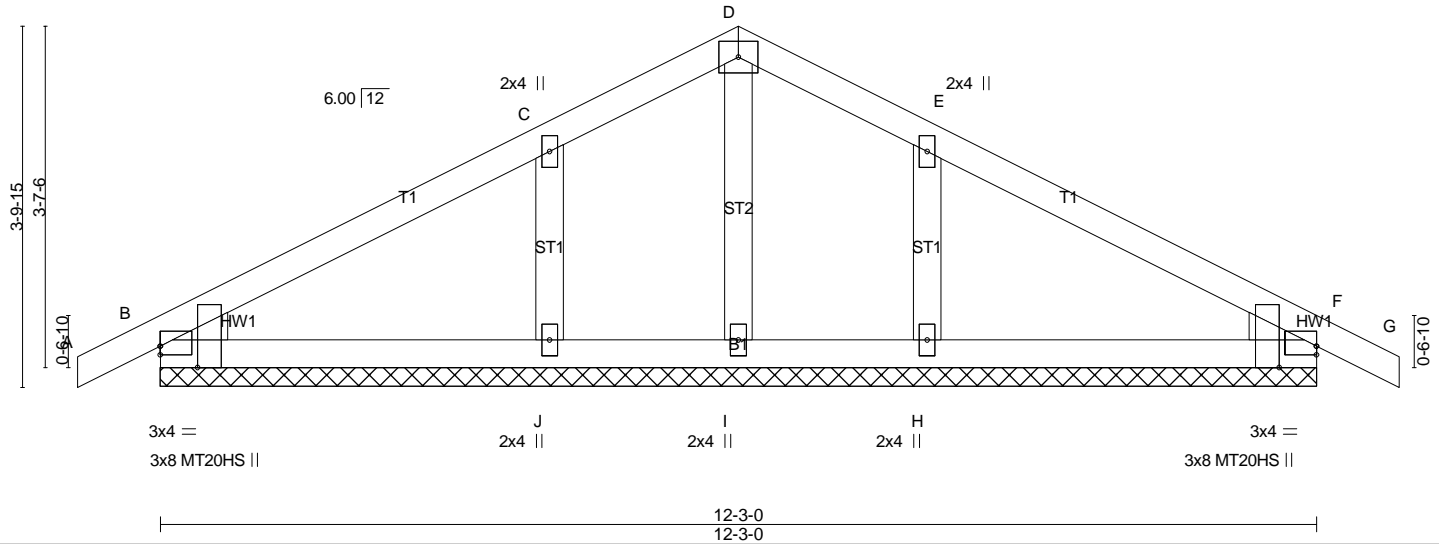

Plate Offsets (X,Y)-- [B:Edge,0-1-2], [B:0-2-11,Edge], [F:Edge,0-1-2], [F:0-2-11,Edge]

LOADING (psf)	SPACING-	2-0-0	CSI.	DEFL.	in	(loc)	l/defl	L/d	PLATES	GRIP
TCLL 20.0	Plate Grip DOL	1.15	TC 0.28	Vert(LL)	0.01	G	n/r	120	MT20	244/190
TCDL 10.0	Lumber DOL	1.15	BC 0.14	Vert(TL)	0.02	G	n/r	120	MT20HS	187/143
BCLL 0.0 *	Rep Stress Incr	YES	WB 0.14	Horz(TL)	0.00	F	n/a	n/a		
BCDL 10.0	Code IRC2009/TPI2007		(Matrix)							
									Weight: 54 lb	FT = 20%

LUMBER-

TOP CHORD 2x4 SP No.2
 BOT CHORD 2x4 SP No.2
 OTHERS 2x4 SP No.3
 WEDGE
 Left: 2x4 SP No.3, Right: 2x4 SP No.3

BRACING-

TOP CHORD Structural wood sheathing directly applied or 6-0-0 oc purlins.
 BOT CHORD Rigid ceiling directly applied or 10-0-0 oc bracing.
 MiTek recommends that Stabilizers and required cross bracing be installed during truss erection, in accordance with Stabilizer Installation guide.

REACTIONS.

All bearings 12-3-0.
 (lb) - Max Horz B=-87(LC 9)
 Max Uplift All uplift 100 lb or less at joint(s) except B=-118(LC 8), F=-135(LC 9), J=-214(LC 8), H=-212(LC 9)
 Max Grav All reactions 250 lb or less at joint(s) B, F, I except J=337(LC 1), H=337(LC 1)

FORCES. (lb) - Max. Comp./Max. Ten. - All forces 250 (lb) or less except when shown.

TOP CHORD C-D=-51/251
 WEBS C-J=-237/477, E-H=-237/477

NOTES-

- Unbalanced roof live loads have been considered for this design.
- Wind: ASCE 7-05; 130mph; TCCL=6.0psf; BCCL=6.0psf; h=25ft; Cat. II; Exp C; enclosed; MWFRS (low-rise) and C-C Exterior(2) zone; end vertical left and right exposed; C-C for members and forces & MWFRS for reactions shown; Lumber DOL=1.60 plate grip DOL=1.60
- Truss designed for wind loads in the plane of the truss only. For studs exposed to wind (normal to the face), see Standard Industry Gable End Details as applicable, or consult qualified building designer as per ANSI/TPI 1.
- This truss has been designed for basic load combinations, which include cases with reductions for multiple concurrent live loads.
- All plates are MT20 plates unless otherwise indicated.
- Gable requires continuous bottom chord bearing.
- Gable studs spaced at 2-0-0 oc.
- This truss has been designed for a 10.0 psf bottom chord live load nonconcurrent with any other live loads.
- * This truss has been designed for a live load of 20.0psf on the bottom chord in all areas where a rectangle 3-6-0 tall by 2-0-0 wide will fit between the bottom chord and any other members.
- Provide mechanical connection (by others) of truss to bearing plate capable of withstanding 118 lb uplift at joint B, 135 lb uplift at joint F, 214 lb uplift at joint J and 212 lb uplift at joint H.
- Beveled plate or shim required to provide full bearing surface with truss chord at joint(s) F.
- This truss is designed in accordance with the 2009 International Residential Code sections R502.11.1 and R802.10.2 and referenced standard ANSI/TPI 1.
- "Semi-rigid pitchbreaks including heels" Member end fixity model was used in the analysis and design of this truss.

LOAD CASE(S) Standard

Job	Truss	Truss Type	Qty	Ply	H&H-NC/Wayfare/
MASTER	C02	COMMON GIRDER	2	2	Job Reference (optional)

Builders FirstSource, N. Charleston, SC

Run: 7.640 s Apr 22 2016 Print: 7.640 s Apr 22 2016 MiTek Industries, Inc. Wed Jan 10 11:33:37 2018 Page 1
 ID:5gbe_Q0JNoiH4zfeQirvLHzQqXF-8JklofREqpaN3X2rGaKiXVoZfyaoiwUdSCYVxazwnaS

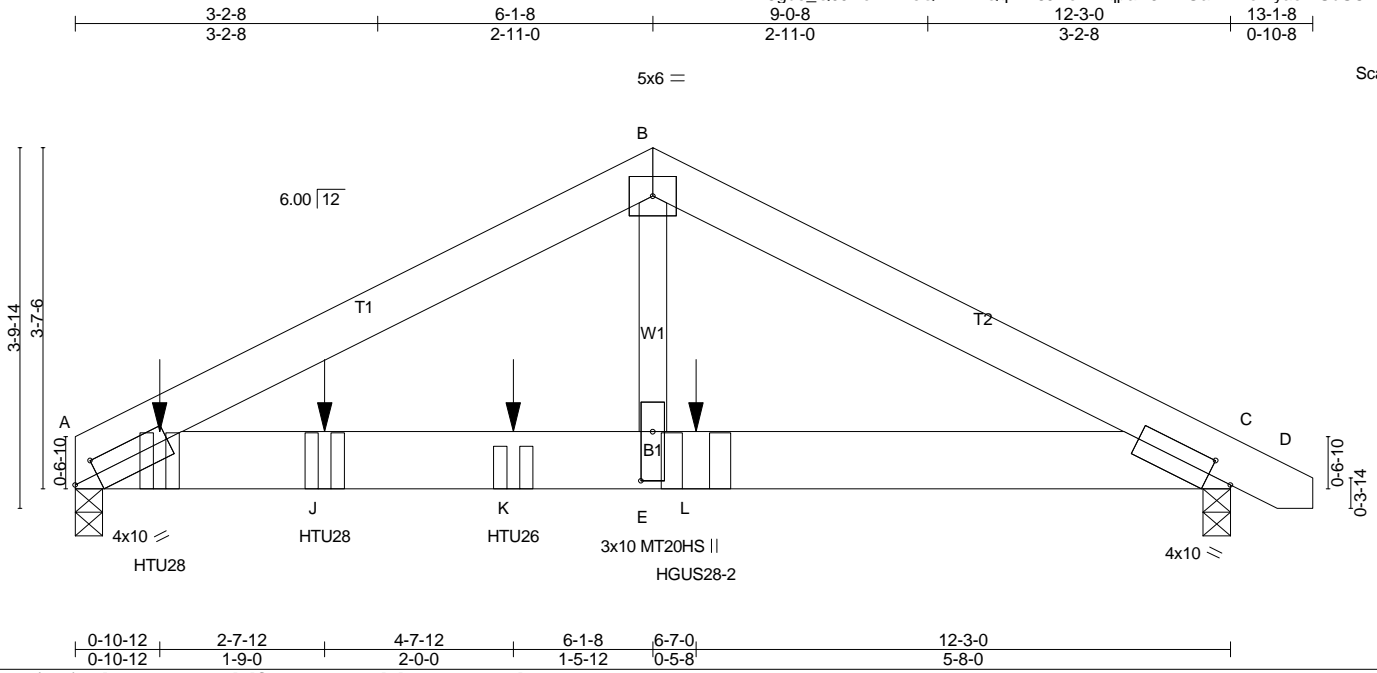

Scale = 1:24.4

Plate Offsets (X,Y)-- [A:0-3-1,0-1-15], [C:0-3-1,0-1-15], [E:0-6-4,0-1-8]

LOADING (psf)	SPACING-	CSI.	DEFL.	in (loc)	l/defl	L/d	PLATES	GRIP
TCLL 20.0	2-0-0	TC 0.54	Vert(LL) -0.06	E-G	>999	360	MT20	244/190
TCDL 10.0	Plate Grip DOL 1.15	BC 0.56	Vert(TL) -0.16	E-G	>934	240	MT20HS	187/143
BCLL 0.0 *	Lumber DOL 1.15	WB 0.59	Horz(TL) 0.02	C	n/a	n/a		
BCDL 10.0	Rep Stress Incr NO	(Matrix-M)	Wind(LL) 0.09	E-G	>999	240		
	Code IRC2009/TPI2007						Weight: 153 lb	FT = 20%

LUMBER-
 TOP CHORD 2x6 SP No.2
 BOT CHORD 2x8 SP DSS
 WEBS 2x4 SP No.2

BRACING-
 TOP CHORD Structural wood sheathing directly applied or 5-6-11 oc purlins.
 BOT CHORD Rigid ceiling directly applied or 10-0-0 oc bracing.

REACTIONS. (lb/size) A=4768/0-3-8 (min. 0-2-13), C=2823/0-3-8 (min. 0-1-11)
 Max Horz A=-101(LC 7)
 Max Uplift A=-1948(LC 6), C=-1392(LC 7)

FORCES. (lb) - Max. Comp./Max. Ten. - All forces 250 (lb) or less except when shown.
 TOP CHORD A-B=-5884/2756, B-C=-5954/2780
 BOT CHORD A-J=-2403/5275, J-K=-2403/5275, E-K=-2403/5275, E-L=-2403/5275, C-L=-2403/5275
 WEBS B-E=-2212/4772

- NOTES-**
- 2-ply truss to be connected together with 10d (0.131"x3") nails as follows:
 Top chords connected as follows: 2x6 - 2 rows staggered at 0-9-0 oc.
 Bottom chords connected as follows: 2x8 - 2 rows staggered at 0-4-0 oc.
 Webs connected as follows: 2x4 - 1 row at 0-9-0 oc.
 - All loads are considered equally applied to all plies, except if noted as front (F) or back (B) face in the LOAD CASE(S) section. Ply to ply connections have been provided to distribute only loads noted as (F) or (B), unless otherwise indicated.
 - Unbalanced roof live loads have been considered for this design.
 - Wind: ASCE 7-05; 130mph; TCDL=6.0psf; BCDL=6.0psf; h=25ft; Cat. II; Exp C; enclosed; MWFRS (low-rise); end vertical left and right exposed; Lumber DOL=1.60 plate grip DOL=1.60
 - This truss has been designed for basic load combinations, which include cases with reductions for multiple concurrent live loads.
 - All plates are MT20 plates unless otherwise indicated.
 - This truss has been designed for a 10.0 psf bottom chord live load nonconcurrent with any other live loads.
 - * This truss has been designed for a live load of 20.0psf on the bottom chord in all areas where a rectangle 3-6-0 tall by 2-0-0 wide will fit between the bottom chord and any other members.
 - Provide mechanical connection (by others) of truss to bearing plate capable of withstanding 1948 lb uplift at joint A and 1392 lb uplift at joint C.
 - This truss is designed in accordance with the 2009 International Residential Code sections R502.11.1 and R802.10.2 and referenced standard ANSI/TPI 1.
 - "Semi-rigid pitchbreaks including heels" Member end fixity model was used in the analysis and design of this truss.
 - Use Simpson Strong-Tie HTU28 (26-10d Girder, 14-10dx1 1/2 Truss, Single Ply Girder) or equivalent spaced at 1-9-0 oc max. starting at 0-10-12 from the left end to 2-7-12 to connect truss(es) A11 (1 ply 2x6 SP), A12 (1 ply 2x6 SP) to back face of bottom chord.
 - Use Simpson Strong-Tie HTU26 (20-10d Girder, 11-10dx1 1/2 Truss, Single Ply Girder) or equivalent at 4-7-12 from the left end to connect truss(es) A13 (1 ply 2x6 SP) to back face of bottom chord.
 - Use Simpson Strong-Tie HGUS28-2 (36-10d Girder, 12-10d Truss) or equivalent at 6-7-0 from the left end to connect truss(es) A14 (2 ply 2x6 SP) to back face of bottom chord.
 - Fill all nail holes where hanger is in contact with lumber.

LOAD CASE(S) Standard
 Continued on page 2

Job	Truss	Truss Type	Qty	Ply	H&H-NC/Wayfare/
MASTER	C02	COMMON GIRDER	2	2	Job Reference (optional)

Builders FirstSource, N. Charleston, SC

Run: 7.640 s Apr 22 2016 Print: 7.640 s Apr 22 2016 MiTek Industries, Inc. Wed Jan 10 11:33:37 2018 Page 2
ID:5gbe_Q0JNoiH4zfeQirvLHzQqXF-8JklofREqpaN3X2rGaKixVoZfyaoiwUdSCYVxazwnaS

LOAD CASE(S) Standard

1) Dead + Roof Live (balanced): Lumber Increase=1.15, Plate Increase=1.15

Uniform Loads (plf)

Vert: A-B=-60, B-D=-60, A-C=-20

Concentrated Loads (lb)

Vert: G=-1345(B) J=-1335(B) K=-1338(B) L=-2552(B)

Job	Truss	Truss Type	Qty	Ply	H&H-NC/Wayfare/
MASTER	D01	GABLE	1	1	Job Reference (optional)

Builders FirstSource, N. Charleston, SC

Run: 7.640 s Apr 22 2016 Print: 7.640 s Apr 22 2016 MiTek Industries, Inc. Wed Jan 10 11:33:38 2018 Page 1
ID:5gbe_Q0JNoiH4zfeQirvLHzQqXF-cvI70?Ssb7iEhhd1qHrx3iLopM1qRVAmhsH2U0zwnaR

0-10-8	12-5-6	17-7-0	18-5-8
0-10-8	12-5-6	5-1-10	0-10-8

Scale = 1:40.7

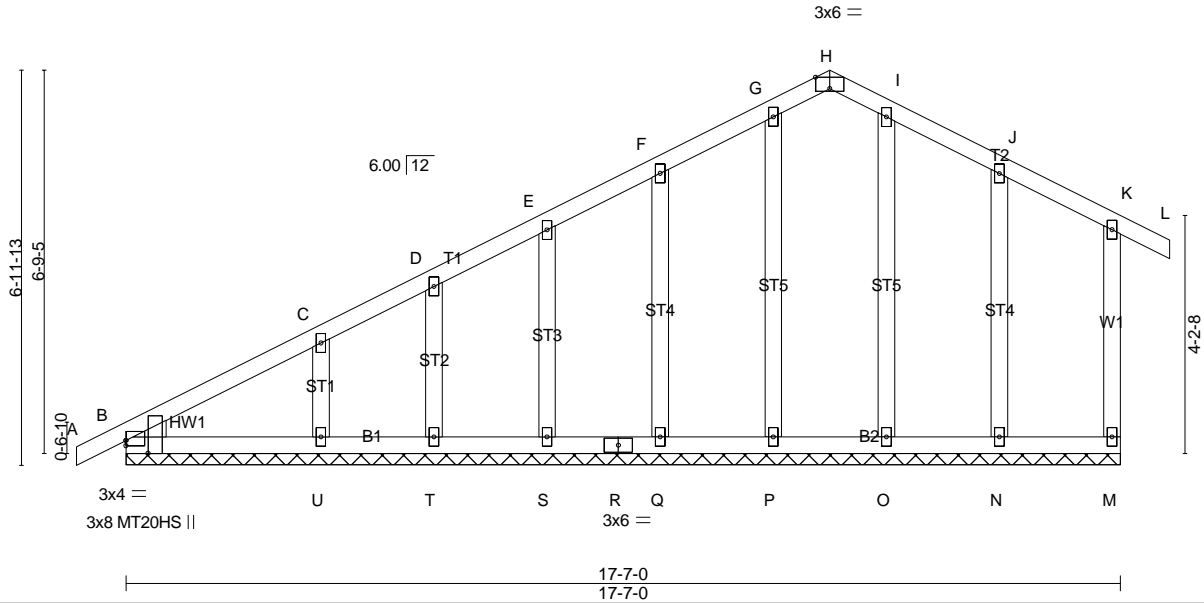

Plate Offsets (X,Y)-- [B:0-2-12,Edge], [B:0-0-0,0-1-2], [H:0-3-0,Edge]

LOADING (psf)	SPACING-	2-0-0	CSI.	DEFL.	in (loc)	l/defl	L/d	PLATES	GRIP
TCLL 20.0	Plate Grip DOL	1.15	TC 0.26	Vert(LL)	-0.00	L	n/r	MT20	244/190
TCDL 10.0	Lumber DOL	1.15	BC 0.12	Vert(TL)	-0.00	L	n/r	MT20HS	187/143
BCLL 0.0 *	Rep Stress Incr	YES	WB 0.11	Horz(TL)	0.00	M	n/a		
BCDL 10.0	Code IRC2009/TPI2007		(Matrix)						
								Weight: 108 lb	FT = 20%

LUMBER-
TOP CHORD 2x4 SP No.2
BOT CHORD 2x4 SP No.2
WEBS 2x4 SP No.2
OTHERS 2x4 SP No.3
WEDGE
Left: 2x4 SP No.3

BRACING-
TOP CHORD Structural wood sheathing directly applied or 6-0-0 oc purlins, except end verticals.
BOT CHORD Rigid ceiling directly applied or 6-0-0 oc bracing.

MiTek recommends that Stabilizers and required cross bracing be installed during truss erection, in accordance with Stabilizer Installation guide.

REACTIONS. All bearings 17-7-0.
(lb) - Max Horz B=317(LC 7)
Max Uplift All uplift 100 lb or less at joint(s) B, P, T except M=-206(LC 9), Q=-129(LC 8), S=-104(LC 8), U=-178(LC 8), N=-130(LC 9)
Max Grav All reactions 250 lb or less at joint(s) M, B, P, Q, S, T, O, N except U=268(LC 1)

FORCES. (lb) - Max. Comp./Max. Ten. - All forces 250 (lb) or less except when shown.
TOP CHORD B-C=-365/118, E-F=-79/269, F-G=-29/400, G-H=-27/384, H-I=-27/386, I-J=-27/396,
J-K=-30/284, K-M=-127/302
WEBS F-Q=-120/271, C-U=-191/369

- NOTES-**
- Unbalanced roof live loads have been considered for this design.
 - Wind: ASCE 7-05; 130mph; TCDL=6.0psf; BCDL=6.0psf; h=25ft; Cat. II; Exp C; enclosed; MWFRS (low-rise) and C-C Exterior(2) zone; end vertical left and right exposed; C-C for members and forces & MWFRS for reactions shown; Lumber DOL=1.60 plate grip DOL=1.60
 - Truss designed for wind loads in the plane of the truss only. For studs exposed to wind (normal to the face), see Standard Industry Gable End Details as applicable, or consult qualified building designer as per ANSI/TPI 1.
 - This truss has been designed for basic load combinations, which include cases with reductions for multiple concurrent live loads.
 - All plates are MT20 plates unless otherwise indicated.
 - All plates are 2x4 MT20 unless otherwise indicated.
 - Gable requires continuous bottom chord bearing.
 - Gable studs spaced at 2-0-0 oc.
 - This truss has been designed for a 10.0 psf bottom chord live load nonconcurrent with any other live loads.
 - * This truss has been designed for a live load of 20.0psf on the bottom chord in all areas where a rectangle 3-6-0 tall by 2-0-0 wide will fit between the bottom chord and any other members.
 - Provide mechanical connection (by others) of truss to bearing plate capable of withstanding 100 lb uplift at joint(s) B, P, T except (jt=lb) M=206, Q=129, S=104, U=178, N=130.
 - This truss is designed in accordance with the 2009 International Residential Code sections R502.11.1 and R802.10.2 and referenced standard ANSI/TPI 1.
 - "Semi-rigid pitchbreaks including heels" Member end fixity model was used in the analysis and design of this truss.

LOAD CASE(S) Standard

Job	Truss	Truss Type	Qty	Ply	H&H-NC/Wayfare/
MASTER	D02	Common	1	1	Job Reference (optional)

Builders FirstSource, N. Charleston, SC

Run: 7.640 s Apr 22 2016 Print: 7.640 s Apr 22 2016 MiTek Industries, Inc. Wed Jan 10 11:33:38 2018 Page 1
 ID:5gbe_Q0JNoiH4zfeQirvLHzQqXF-cv170?Ssb7iEhhd1qHrx3iLjRMusRLhmhsH2U0zwnaR

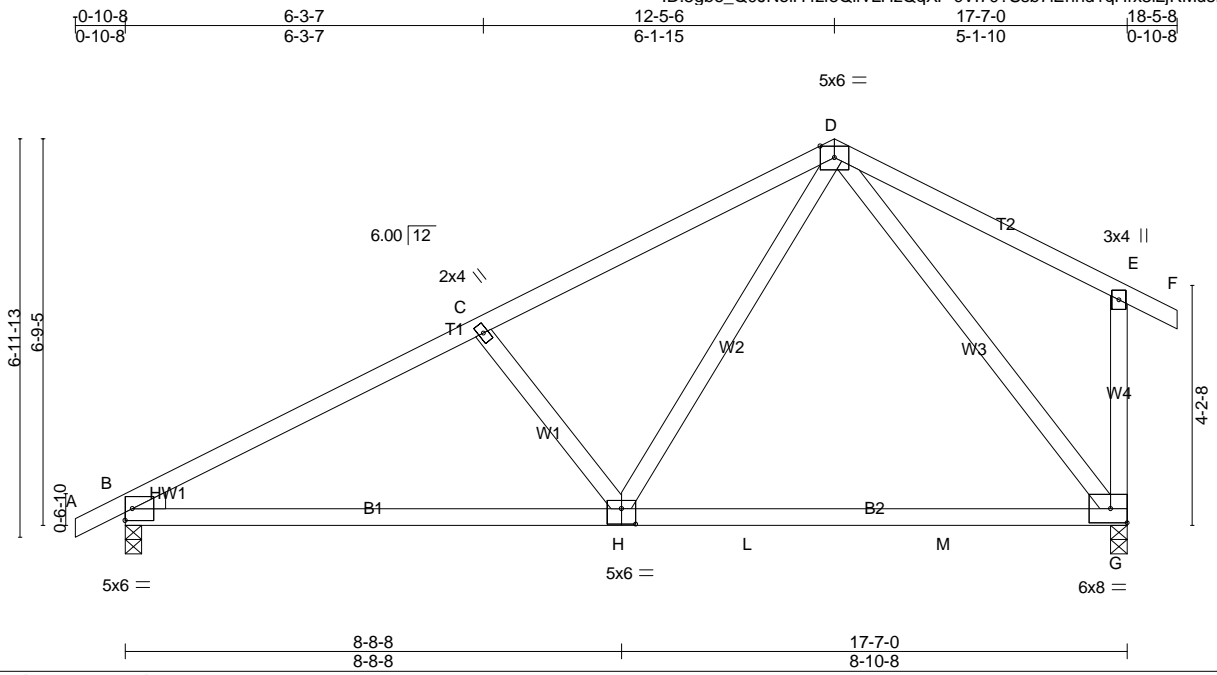

Scale = 1:40.4

Plate Offsets (X,Y)-- [H:0-3-0,0-3-4]

LOADING (psf)	SPACING-	2-0-0	CSI.	DEFL.	in	(loc)	l/defl	L/d	PLATES	GRIP
TCLL 20.0	Plate Grip DOL	1.15	TC 0.61	Vert(LL)	-0.21	G-H	>998	360	MT20	244/190
TCDL 10.0	Lumber DOL	1.15	BC 0.69	Vert(TL)	-0.40	G-H	>523	240		
BCLL 0.0 *	Rep Stress Incr	YES	WB 0.72	Horz(TL)	0.02	G	n/a	n/a		
BCDL 10.0	Code IRC2009/TPI2007		(Matrix-S)	Wind(LL)	0.08	H-K	>999	240		
									Weight: 93 lb	FT = 20%

LUMBER-
 TOP CHORD 2x4 SP No.2
 BOT CHORD 2x4 SP No.2
 WEBS 2x4 SP No.3 *Except*
 W4: 2x4 SP No.2
 WEDGE
 Left: 2x4 SP No.3

BRACING-
 TOP CHORD Structural wood sheathing directly applied, except end verticals.
 BOT CHORD Rigid ceiling directly applied.
 MiTek recommends that Stabilizers and required cross bracing be installed during truss erection, in accordance with Stabilizer Installation guide.

REACTIONS. (lb/size) B=750/0-3-8 (min. 0-1-8), G=759/0-3-8 (min. 0-1-8)
 Max Horz B=314(LC 7)
 Max Uplift B=-355(LC 8), G=-277(LC 9)

FORCES. (lb) - Max. Comp./Max. Ten. - All forces 250 (lb) or less except when shown.
 TOP CHORD B-C=-1045/975, C-D=-832/895, D-E=-118/380, E-G=-236/439
 BOT CHORD B-H=-1078/882, H-L=-461/386, L-M=-461/386, G-M=-461/386
 WEBS C-H=-372/638, D-H=-469/575, D-G=-576/605

- NOTES-**
- 1) Unbalanced roof live loads have been considered for this design.
 - 2) Wind: ASCE 7-05; 130mph; TCDL=6.0psf; BCDL=6.0psf; h=25ft; Cat. II; Exp C; enclosed; MWFRS (low-rise) and C-C Exterior(2) zone; end vertical left and right exposed; C-C for members and forces & MWFRS for reactions shown; Lumber DOL=1.60 plate grip DOL=1.60
 - 3) This truss has been designed for basic load combinations, which include cases with reductions for multiple concurrent live loads.
 - 4) This truss has been designed for a 10.0 psf bottom chord live load nonconcurrent with any other live loads.
 - 5) * This truss has been designed for a live load of 20.0psf on the bottom chord in all areas where a rectangle 3-6-0 tall by 2-0-0 wide will fit between the bottom chord and any other members, with BCDL = 10.0psf.
 - 6) Provide mechanical connection (by others) of truss to bearing plate capable of withstanding 100 lb uplift at joint(s) except (jt=lb) B=355, G=277.
 - 7) This truss is designed in accordance with the 2009 International Residential Code sections R502.11.1 and R802.10.2 and referenced standard ANSI/TPI 1.
 - 8) This truss design requires that a minimum of 7/16" structural wood sheathing be applied directly to the top chord and 1/2" gypsum sheetrock be applied directly to the bottom chord.

LOAD CASE(S) Standard

Job	Truss	Truss Type	Qty	Ply	H&H-NC/Wayfare/
MASTER	D03	Common Girder	1	2	Job Reference (optional)

Builders FirstSource, N. Charleston, SC

Run: 7.640 s Apr 22 2016 Print: 7.640 s Apr 22 2016 MiTek Industries, Inc. Wed Jan 10 11:33:39 2018 Page 1
ID:5gbe_Q0JNoiH4zfeQirvLHzQqXF-4isVDLTUMRq5lrCEN?NacwuqvmF8AkWwwW1c0SzwnaQ

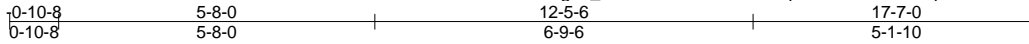

Scale = 1:41.3

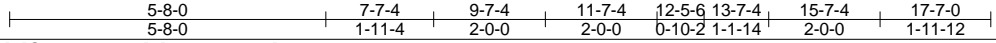
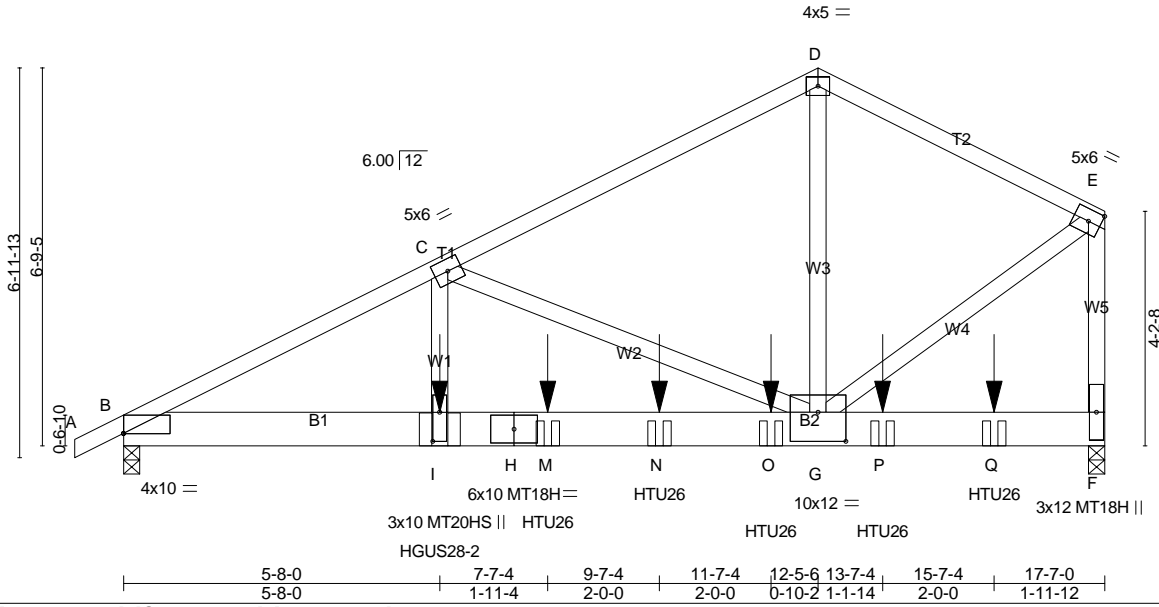

Plate Offsets (X,Y)-- [B:0-0-0,0-0-1], [G:0-6-0,0-6-4], [I:0-6-4,0-1-8]

LOADING (psf)	SPACING-	CSI.	DEFL.	in (loc)	l/defl	L/d	PLATES	GRIP
TCLL 20.0	2-0-0	TC 0.88	Vert(LL) -0.13	G-I	>999	360	MT20	244/190
TCDL 10.0	Plate Grip DOL 1.15	BC 0.63	Vert(TL) -0.32	G-I	>648	240	MT20HS	187/143
BCLL 0.0 *	Lumber DOL 1.15	WB 1.00	Horz(TL) 0.04	F	n/a	n/a	MT18H	244/190
BCDL 10.0	Rep Stress Incr NO	(Matrix-M)	Wind(LL) 0.19	G-I	>999	240	Weight: 244 lb	FT = 20%
	Code IRC2009/TPI2007							

LUMBER-
 TOP CHORD 2x4 SP No.2
 BOT CHORD 2x8 SP DSS
 WEBS 2x4 SP No.2

BRACING-
 TOP CHORD Structural wood sheathing directly applied, except end verticals.
 BOT CHORD Rigid ceiling directly applied or 10-0-0 oc bracing.

REACTIONS. (lb/size) B=4753/0-3-8 (min. 0-2-13), F=6019/0-3-8 (req. 0-3-9)
 Max Horz B=337(LC 5)
 Max Uplift B=-2275(LC 6), F=-2393(LC 6)

FORCES. (lb) - Max. Comp./Max. Ten. - All forces 250 (lb) or less except when shown.
 TOP CHORD B-C=-9753/4533, C-D=-4721/1955, D-E=-4691/2000, E-F=-5342/2197
 BOT CHORD B-I=-4067/8660, H-I=-4067/8660, H-M=-4067/8660, M-N=-4067/8660, N-O=-4067/8660, G-O=-4067/8660
 WEBS C-I=-1931/3877, C-G=-4928/2722, D-G=-1524/3816, E-G=-2066/5164

- NOTES-**
- 2-ply truss to be connected together with 10d (0.131"x3") nails as follows:
 Top chords connected as follows: 2x4 - 1 row at 0-7-0 oc.
 Bottom chords connected as follows: 2x8 - 2 rows staggered at 0-4-0 oc.
 Webs connected as follows: 2x4 - 1 row at 0-9-0 oc.
 - All loads are considered equally applied to all plies, except if noted as front (F) or back (B) face in the LOAD CASE(S) section. Ply to ply connections have been provided to distribute only loads noted as (F) or (B), unless otherwise indicated.
 - Unbalanced roof live loads have been considered for this design.
 - Wind: ASCE 7-05; 130mph; TCDL=6.0psf; BCDL=6.0psf; h=25ft; Cat. II; Exp C; enclosed; MWFRS (low-rise); end vertical left and right exposed; Lumber DOL=1.60 plate grip DOL=1.60
 - This truss has been designed for basic load combinations, which include cases with reductions for multiple concurrent live loads.
 - All plates are MT20 plates unless otherwise indicated.
 - This truss has been designed for a 10.0 psf bottom chord live load nonconcurrent with any other live loads.
 - * This truss has been designed for a live load of 20.0psf on the bottom chord in all areas where a rectangle 3-6-0 tall by 2-0-0 wide will fit between the bottom chord and any other members.
 - WARNING: Required bearing size at joint(s) F greater than input bearing size.
 - Provide mechanical connection (by others) of truss to bearing plate capable of withstanding 100 lb uplift at joint(s) except (jt=lb) B=2275, F=2393.
 - This truss is designed in accordance with the 2009 International Residential Code sections R502.11.1 and R802.10.2 and referenced standard ANSI/TPI 1.
 - "Semi-rigid pitchbreaks including heels" Member end fixity model was used in the analysis and design of this truss.
 - Use Simpson Strong-Tie HGUS28-2 (36-10d Girder, 12-10d Truss) or equivalent at 5-8-0 from the left end to connect truss(es) A01 (2 ply 2x6 SP) to back face of bottom chord.
 - Use Simpson Strong-Tie HTU26 (20-10d Girder, 11-10dx1 1/2 Truss, Single Ply Girder) or equivalent spaced at 2-0-0 oc max. starting at 7-7-4 from the left end to 15-7-4 to connect truss(es) A02 (1 ply 2x4 SP), A03 (1 ply 2x6 SP), A04 (1 ply 2x6 SP), A05 (1 ply 2x6 SP), A06 (1 ply 2x6 SP) to back face of bottom chord.
 - Fill all nail holes where hanger is in contact with lumber.

LOAD CASE(S) Standard
 Continued on page 2

Job	Truss	Truss Type	Qty	Ply	H&H-NC/Wayfare/
MASTER	D03	Common Girder	1	2	Job Reference (optional)

Builders FirstSource, N. Charleston, SC

Run: 7.640 s Apr 22 2016 Print: 7.640 s Apr 22 2016 MiTek Industries, Inc. Wed Jan 10 11:33:39 2018 Page 2
 ID:5gbe_Q0JNoih4zfeQirvLHzQqXF-4isVDLTUMRq5IrCEN?NacwuqvmF8AkWwwW1c0SzwnaQ

LOAD CASE(S) Standard

1) Dead + Roof Live (balanced): Lumber Increase=1.15, Plate Increase=1.15

Uniform Loads (plf)

Vert: A-D=-60, D-E=-60, F-J=-20

Concentrated Loads (lb)

Vert: I=-2551(B) M=-1350(B) N=-1356(B) O=-1356(B) P=-1356(B) Q=-1356(B)

Job	Truss	Truss Type	Qty	Ply	H&H-NC/Wayfare/
MASTER	J01	JACK-OPEN	60	1	Job Reference (optional)

Builders FirstSource, N. Charleston, SC

Run: 7.640 s Apr 22 2016 Print: 7.640 s Apr 22 2016 MiTek Industries, Inc. Wed Jan 10 11:33:39 2018 Page 1
 ID:5gbe_Q0JNoiH4zfeQirvLHzQqXF-4isVDLTUMRq5lrCEN?NAcwuy6mK6Az7wwW1c0SzwnaQ

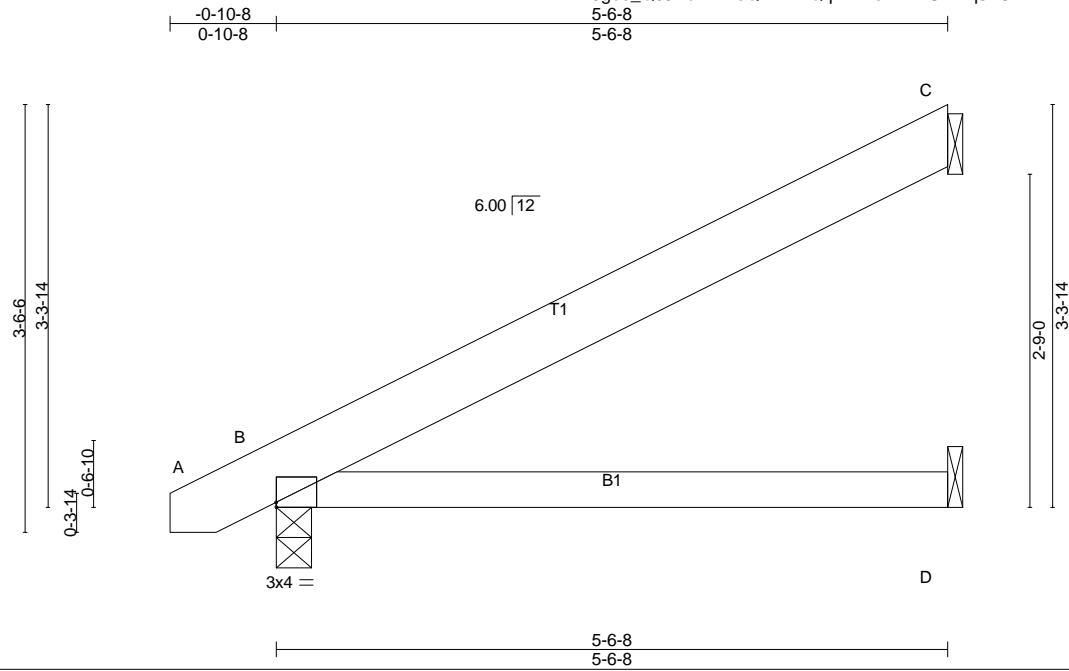

Scale = 1:19.0

Plate Offsets (X,Y)-- [B:Edge,0-0-8]

LOADING (psf)	SPACING-	2-0-0	CSI.	DEFL.	in	(loc)	l/defl	L/d	PLATES	GRIP
TCLL 20.0	Plate Grip DOL	1.15	TC 0.35	Vert(LL)	-0.02	D-G	>999	360	MT20	244/190
TCDL 10.0	Lumber DOL	1.15	BC 0.31	Vert(TL)	-0.07	D-G	>946	240		
BCLL 0.0 *	Rep Stress Incr	YES	WB 0.00	Horz(TL)	-0.01	C	n/a	n/a		
BCDL 10.0	Code IRC2009/TPI2007		(Matrix-S)	Wind(LL)	0.05	D-G	>999	240		
									Weight: 25 lb	FT = 20%

LUMBER-

TOP CHORD 2x6 SP No.2
 BOT CHORD 2x4 SP No.2

BRACING-

TOP CHORD Structural wood sheathing directly applied.
 BOT CHORD Rigid ceiling directly applied.

REACTIONS. (lb/size) C=165/Mechanical, B=264/0-3-8 (min. 0-1-8), D=51/Mechanical
 Max Horz B=198(LC 8)
 Max UpliftC=-155(LC 8), B=-115(LC 8)
 Max GravC=165(LC 1), B=264(LC 1), D=86(LC 3)

FORCES. (lb) - Max. Comp./Max. Ten. - All forces 250 (lb) or less except when shown.

NOTES-

- 1) Wind: ASCE 7-05; 130mph; TCDL=6.0psf; BCDL=6.0psf; h=25ft; Cat. II; Exp C; enclosed; MWFRS (low-rise) and C-C Exterior(2) zone; end vertical left and right exposed;C-C for members and forces & MWFRS for reactions shown; Lumber DOL=1.60 plate grip DOL=1.60
- 2) This truss has been designed for basic load combinations, which include cases with reductions for multiple concurrent live loads.
- 3) This truss has been designed for a 10.0 psf bottom chord live load nonconcurrent with any other live loads.
- 4) * This truss has been designed for a live load of 20.0psf on the bottom chord in all areas where a rectangle 3-6-0 tall by 2-0-0 wide will fit between the bottom chord and any other members.
- 5) Refer to girder(s) for truss to truss connections.
- 6) Provide mechanical connection (by others) of truss to bearing plate capable of withstanding 100 lb uplift at joint(s) except (jt=lb) C=155, B=115.
- 7) This truss is designed in accordance with the 2009 International Residential Code sections R502.11.1 and R802.10.2 and referenced standard ANSI/TPI 1.
- 8) This truss design requires that a minimum of 7/16" structural wood sheathing be applied directly to the top chord and 1/2" gypsum sheetrock be applied directly to the bottom chord.

LOAD CASE(S) Standard

Job	Truss	Truss Type	Qty	Ply	H&H-NC/Wayfare/
MASTER	J02	HALF HIP	4	1	Job Reference (optional)

Builders FirstSource, N. Charleston, SC

Run: 7.640 s Apr 22 2016 Print: 7.640 s Apr 22 2016 MiTek Industries, Inc. Wed Jan 10 11:33:40 2018 Page 1
ID:5gbe_Q0JNoih4zfeQirvLHzQqXF-YuQtQgT67kyyw_nQxiuP87Q7jAZcvPg38Am9YvzwnaP

Scale = 1:15.1

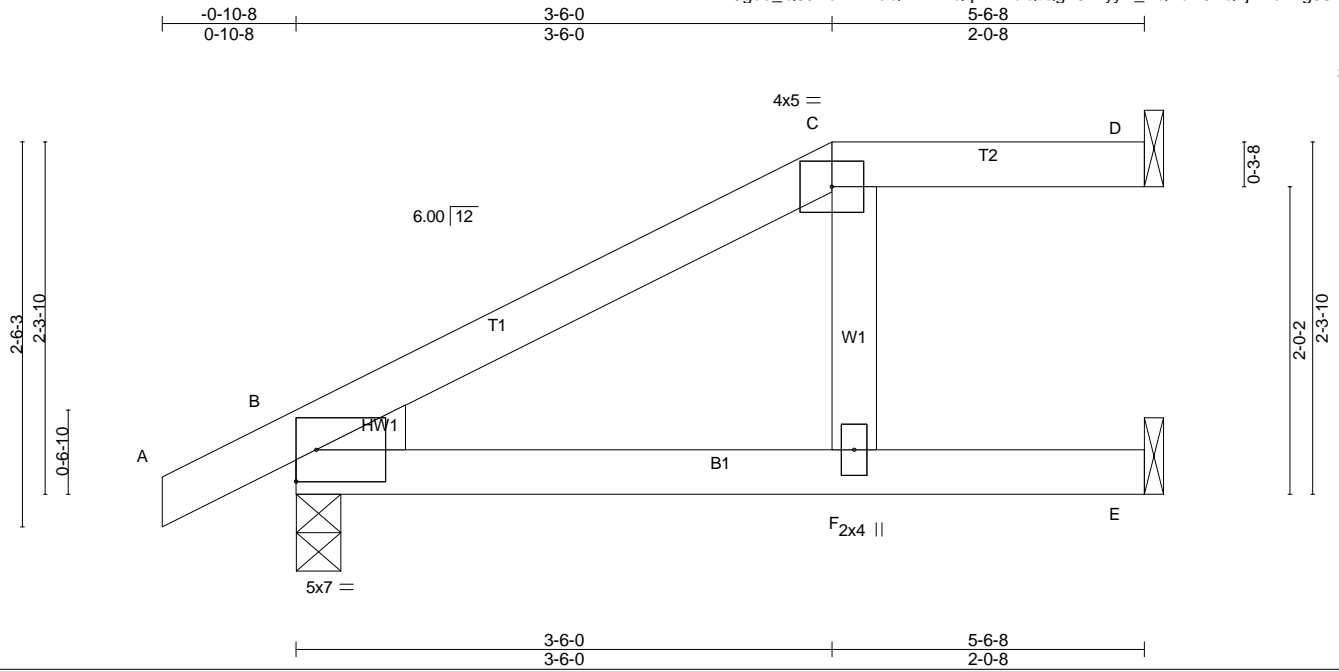

LOADING (psf)	SPACING-	CSI.	DEFL.	PLATES	GRIP
TCLL 20.0	2-0-0	TC 0.36	in (loc) l/defl L/d	MT20	244/190
TCDL 10.0	Plate Grip DOL 1.15	BC 0.74	Vert(LL) -0.07 F-I >999 360		
BCLL 0.0 *	Lumber DOL 1.15	WB 0.11	Vert(TL) -0.18 F-I >369 240		
BCDL 10.0	Rep Stress Incr YES	(Matrix-S)	Horz(TL) -0.11 D n/a n/a		
	Code IRC2009/TPI2007		Wind(LL) 0.19 F-I >346 240	Weight: 22 lb	FT = 20%

LUMBER-
 TOP CHORD 2x4 SP No.2
 BOT CHORD 2x4 SP No.2
 WEBS 2x4 SP No.3
 WEDGE
 Left: 2x4 SP No.3

BRACING-
 TOP CHORD Structural wood sheathing directly applied, except
 2-0-0 oc purlins: C-D.
 BOT CHORD Rigid ceiling directly applied.

MiTek recommends that Stabilizers and required cross bracing be installed during truss erection, in accordance with Stabilizer Installation guide.

REACTIONS. (lb/size) D=59/Mechanical, B=276/0-3-8 (min. 0-1-8), E=156/Mechanical
 Max Horz B=149(LC 8)
 Max Uplift D=-48(LC 6), B=-148(LC 8), E=-54(LC 8)

FORCES. (lb) - Max. Comp./Max. Ten. - All forces 250 (lb) or less except when shown.
 WEBS C-F=-172/368

- NOTES-**
- 1) Unbalanced roof live loads have been considered for this design.
 - 2) Wind: ASCE 7-05; 130mph; TCDL=6.0psf; BCDL=6.0psf; h=25ft; Cat. II; Exp C; enclosed; MWFRS (low-rise) and C-C Exterior(2) zone; end vertical left and right exposed; C-C for members and forces & MWFRS for reactions shown; Lumber DOL=1.60 plate grip DOL=1.60
 - 3) This truss has been designed for basic load combinations, which include cases with reductions for multiple concurrent live loads.
 - 4) Provide adequate drainage to prevent water ponding.
 - 5) This truss has been designed for a 10.0 psf bottom chord live load nonconcurrent with any other live loads.
 - 6) * This truss has been designed for a live load of 20.0psf on the bottom chord in all areas where a rectangle 3-6-0 tall by 2-0-0 wide will fit between the bottom chord and any other members.
 - 7) Refer to girder(s) for truss to truss connections.
 - 8) Provide mechanical connection (by others) of truss to bearing plate capable of withstanding 100 lb uplift at joint(s) D, E except (jt=lb) B=148.
 - 9) This truss is designed in accordance with the 2009 International Residential Code sections R502.11.1 and R802.10.2 and referenced standard ANSI/TPI 1.
 - 10) This truss design requires that a minimum of 7/16" structural wood sheathing be applied directly to the top chord and 1/2" gypsum sheetrock be applied directly to the bottom chord.
 - 11) Graphical purlin representation does not depict the size or the orientation of the purlin along the top and/or bottom chord.

LOAD CASE(S) Standard

Job	Truss	Truss Type	Qty	Ply	H&H-NC/Wayfare/
MASTER	J03	HALF HIP GIRDER	4	1	Job Reference (optional)

Builders FirstSource, N. Charleston, SC

Run: 7.640 s Apr 22 2016 Print: 7.640 s Apr 22 2016 MiTek Industries, Inc. Wed Jan 10 11:33:41 2018 Page 1
ID:5gbe_Q0JNoiH4zfeQirvLHzQqXF-04_Fe0Ukt24pY8McVQPehLzI0Z0wetgDNqWj4LzwnaO

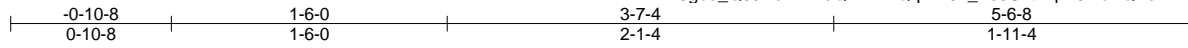

Scale = 1:12.5

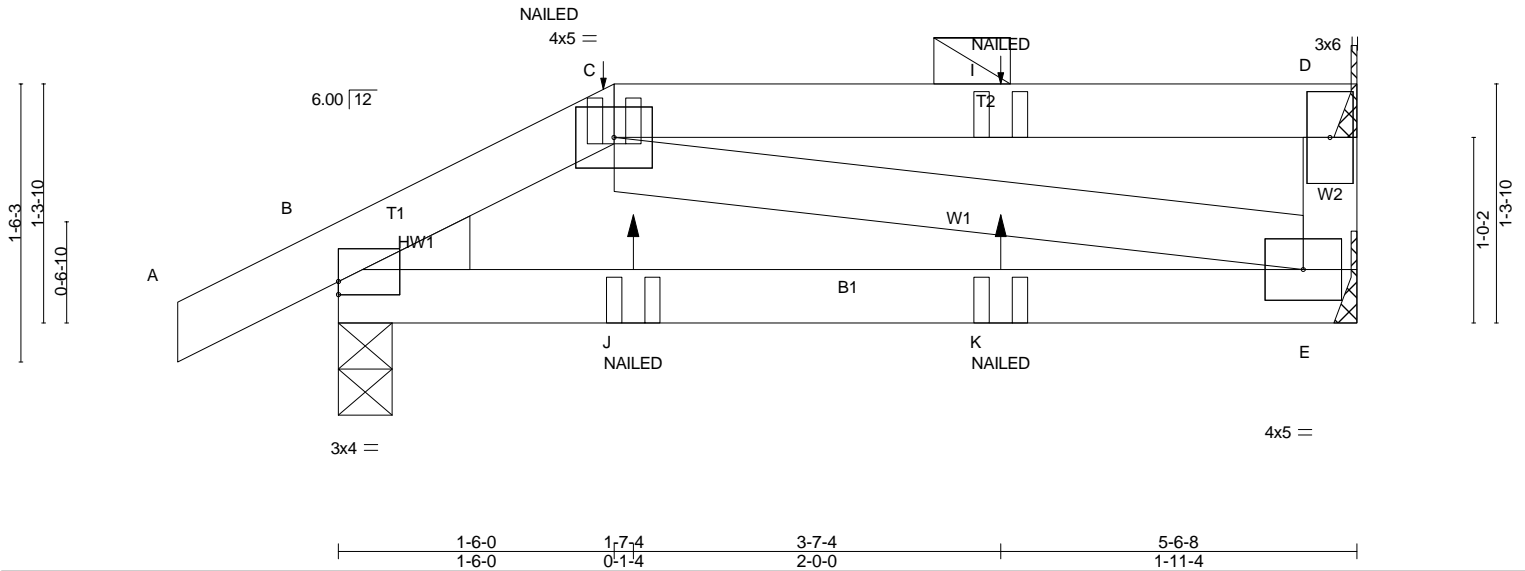

Plate Offsets (X,Y)-- [B:Edge,0-0-14]

LOADING (psf)	SPACING-	2-0-0	CSI.	DEFL.	in	(loc)	l/defl	L/d	PLATES	GRIP
TCLL 20.0	Plate Grip DOL	1.15	TC 0.33	Vert(LL)	-0.02	E-H	>999	360	MT20	244/190
TCDL 10.0	Lumber DOL	1.15	BC 0.29	Vert(TL)	-0.06	E-H	>999	240		
BCLL 0.0 *	Rep Stress Incr	NO	WB 0.06	Horz(TL)	0.00	D	n/a	n/a		
BCDL 10.0	Code IRC2009/TPI2007		(Matrix-M)	Wind(LL)	0.01	E-H	>999	240		
									Weight: 26 lb	FT = 20%

LUMBER-
TOP CHORD 2x4 SP No.2
BOT CHORD 2x4 SP No.2
WEBS 2x4 SP No.2
WEDGE
Left: 2x4 SP No.3

BRACING-
TOP CHORD Structural wood sheathing directly applied or 5-6-8 oc purlins, except end verticals, and 2-0-0 oc purlins: C-D.
BOT CHORD Rigid ceiling directly applied or 10-0-0 oc bracing.

MiTek recommends that Stabilizers and required cross bracing be installed during truss erection, in accordance with Stabilizer Installation guide.

REACTIONS. (lb/size) D=117/Mechanical, E=92/Mechanical, B=273/0-3-8 (min. 0-1-8)
Max Horz B=74(LC 16)
Max Uplift D=-95(LC 4), E=-25(LC 5), B=-166(LC 6)
Max Grav D=117(LC 1), E=118(LC 3), B=273(LC 1)

FORCES. (lb) - Max. Comp./Max. Ten. - All forces 250 (lb) or less except when shown.

- NOTES-**
- 1) Unbalanced roof live loads have been considered for this design.
 - 2) Wind: ASCE 7-05; 130mph; TCDL=6.0psf; BCDL=6.0psf; h=25ft; Cat. II; Exp C; enclosed; MWFRS (low-rise); end vertical left and right exposed; Lumber DOL=1.60 plate grip DOL=1.60
 - 3) This truss has been designed for basic load combinations, which include cases with reductions for multiple concurrent live loads.
 - 4) Provide adequate drainage to prevent water ponding.
 - 5) This truss has been designed for a 10.0 psf bottom chord live load nonconcurrent with any other live loads.
 - 6) * This truss has been designed for a live load of 20.0psf on the bottom chord in all areas where a rectangle 3-6-0 tall by 2-0-0 wide will fit between the bottom chord and any other members.
 - 7) Refer to girder(s) for truss to truss connections.
 - 8) Provide metal plate or equivalent at bearing(s) D to support reaction shown.
 - 9) Provide mechanical connection (by others) of truss to bearing plate capable of withstanding 100 lb uplift at joint(s) D, E except (jt=lb) B=166.
 - 10) This truss is designed in accordance with the 2009 International Residential Code sections R502.11.1 and R802.10.2 and referenced standard ANSI/TPI 1.
 - 11) "Semi-rigid pitchbreaks including heels" Member end fixity model was used in the analysis and design of this truss.
 - 12) Graphical purlin representation does not depict the size or the orientation of the purlin along the top and/or bottom chord.
 - 13) Gap between inside of top chord bearing and first diagonal or vertical web shall not exceed 0.500in.
 - 14) "NAILED" indicates 3-10d (0.148"x3") or 3-12d (0.148"x3.25") toe-nails. For more details refer to MiTek's ST-TOENAIL Detail.
 - 15) In the LOAD CASE(S) section, loads applied to the face of the truss are noted as front (F) or back (B).

LOAD CASE(S) Standard

- 1) Dead + Roof Live (balanced): Lumber Increase=1.15, Plate Increase=1.15
Uniform Loads (plf)
Vert: A-C=-60, C-D=-60, E-F=-20
Concentrated Loads (lb)
Vert: J=2(F) K=2(F)

Job	Truss	Truss Type	Qty	Ply	H&H-NC/Wayfare/
MASTER	J04	JACK-OPEN	8	1	Job Reference (optional)

Builders FirstSource, N. Charleston, SC

Run: 7.640 s Apr 22 2016 Print: 7.640 s Apr 22 2016 MiTek Industries, Inc. Wed Jan 10 11:33:41 2018 Page 1
ID:5gbe_Q0JNoiH4zfeQirvLHzQqXF-04_Fe0Ukt24pY8McVQPehLzMXZ4_etdDNqWj4LzwnaO

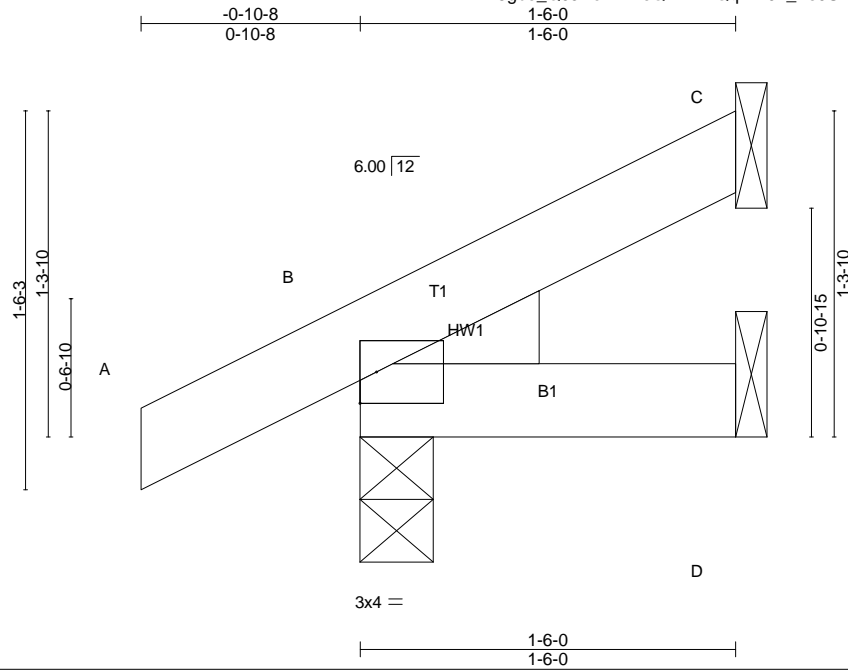

Scale = 1:9.2

LOADING (psf)	SPACING-	CSI.	DEFL.	in (loc)	l/defl	L/d	PLATES	GRIP
TCLL 20.0	2-0-0	TC 0.10	Vert(LL) -0.00	G	>999	360	MT20	244/190
TCDL 10.0	Plate Grip DOL 1.15	BC 0.03	Vert(TL) -0.00	G	>999	240		
BCLL 0.0 *	Lumber DOL 1.15	WB 0.00	Horz(TL) -0.00	C	n/a	n/a		
BCDL 10.0	Rep Stress Incr YES	(Matrix-M)	Wind(LL) 0.00	G	>999	240		
	Code IRC2009/TPI2007						Weight: 7 lb	FT = 20%

LUMBER-
TOP CHORD 2x4 SP No.2
BOT CHORD 2x4 SP No.2
WEDGE
Left: 2x4 SP No.3

BRACING-
TOP CHORD
BOT CHORD

Structural wood sheathing directly applied or 1-6-0 oc purlins.
Rigid ceiling directly applied or 10-0-0 oc bracing.

MiTek recommends that Stabilizers and required cross bracing be installed during truss erection, in accordance with Stabilizer Installation guide.

REACTIONS. (lb/size) C=33/Mechanical, B=128/0-3-8 (min. 0-1-8), D=12/Mechanical
Max Horz B=87(LC 8)
Max Uplift C=-33(LC 8), B=-101(LC 8)
Max Grav C=33(LC 1), B=128(LC 1), D=25(LC 3)

FORCES. (lb) - Max. Comp./Max. Ten. - All forces 250 (lb) or less except when shown.

- NOTES-**
- 1) Wind: ASCE 7-05; 130mph; TCDL=6.0psf; BCDL=6.0psf; h=25ft; Cat. II; Exp C; enclosed; MWFRS (low-rise) and C-C Exterior(2) zone; end vertical left exposed; C-C for members and forces & MWFRS for reactions shown; Lumber DOL=1.60 plate grip DOL=1.60
 - 2) This truss has been designed for basic load combinations, which include cases with reductions for multiple concurrent live loads.
 - 3) This truss has been designed for a 10.0 psf bottom chord live load nonconcurrent with any other live loads.
 - 4) * This truss has been designed for a live load of 20.0psf on the bottom chord in all areas where a rectangle 3-6-0 tall by 2-0-0 wide will fit between the bottom chord and any other members.
 - 5) Refer to girder(s) for truss to truss connections.
 - 6) Provide mechanical connection (by others) of truss to bearing plate capable of withstanding 100 lb uplift at joint(s) C except (jt=lb) B=101.
 - 7) This truss is designed in accordance with the 2009 International Residential Code sections R502.11.1 and R802.10.2 and referenced standard ANSI/TPI 1.
 - 8) "Semi-rigid pitchbreaks including heels" Member end fixity model was used in the analysis and design of this truss.

LOAD CASE(S) Standard

Job	Truss	Truss Type	Qty	Ply	H&H-NC/Wayfare/
MASTER	J05	MONOPITCH	12	1	

Builders FirstSource, N. Charleston, SC

Run: 7.640 s Apr 22 2016 Print: 7.640 s Apr 22 2016 MiTek Industries, Inc. Wed Jan 10 11:33:42 2018 Page 1
 ID:5gbe_Q0JNoiH4zfeQirvLHzQqXF-UHYerMVMMeMCg9lpx37wtEYWQhzHZNKtMcTFGdnzwnaH

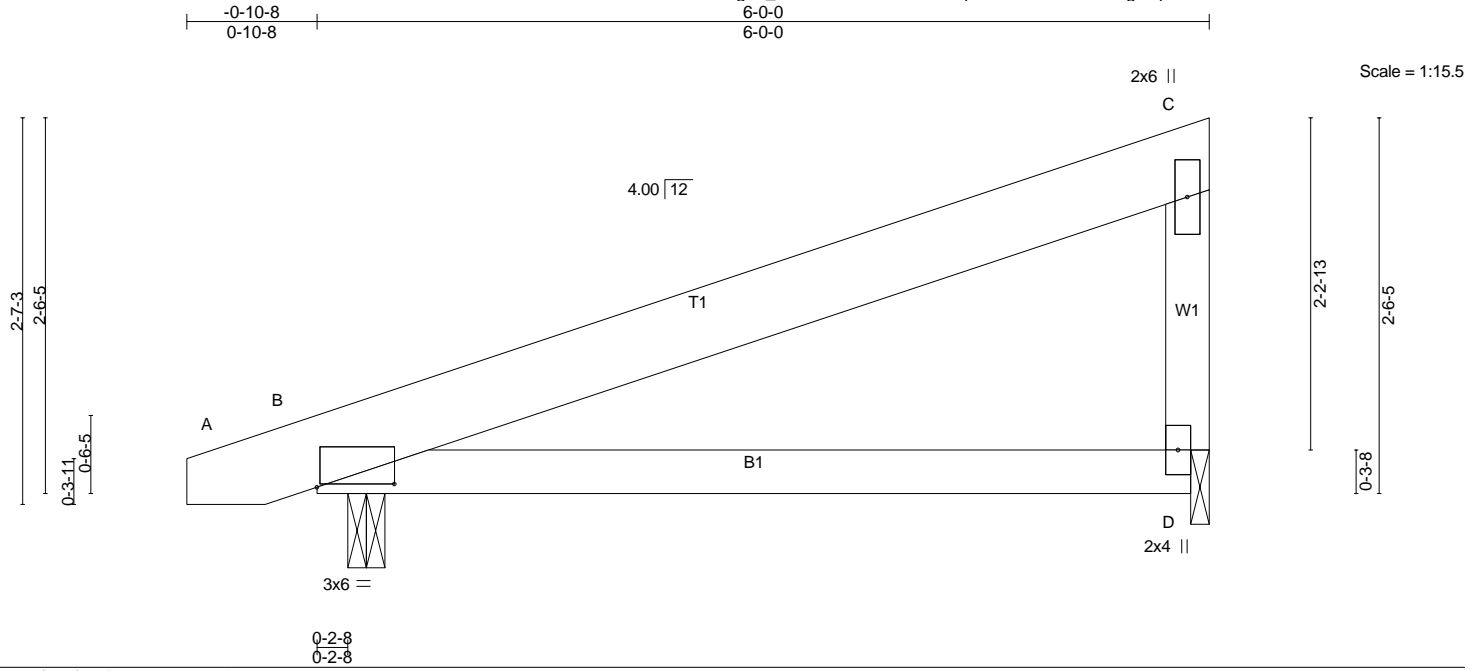

Plate Offsets (X,Y)-- [B:0-6-4,0-0-4]

LOADING (psf)	SPACING-	2-0-0	CSI.	DEFL.	in	(loc)	l/defl	L/d	PLATES	GRIP
TCLL 20.0	Plate Grip DOL	1.15	TC 0.52	Vert(LL)	-0.03	D-G	>999	360	MT20	244/190
TCDL 10.0	Lumber DOL	1.15	BC 0.58	Vert(TL)	-0.08	D-G	>850	240		
BCLL 0.0 *	Rep Stress Incr	YES	WB 0.00	Horz(TL)	-0.01	B	n/a	n/a		
BCDL 10.0	Code IRC2009/TPI2007		(Matrix-S)	Wind(LL)	0.16	D-G	>431	240		
									Weight: 28 lb	FT = 20%

LUMBER-
 TOP CHORD 2x6 SP No.2
 BOT CHORD 2x4 SP No.2
 WEBS 2x4 SP No.2

BRACING-
 TOP CHORD Structural wood sheathing directly applied, except end verticals.
 BOT CHORD Rigid ceiling directly applied.

MiTek recommends that Stabilizers and required cross bracing be installed during truss erection, in accordance with Stabilizer Installation guide.

REACTIONS. (lb/size) B=275/0-3-0 (min. 0-1-8), D=230/0-1-8 (min. 0-1-8)
 Max Horz B=137(LC 6)
 Max Uplift B=-279(LC 6), D=-263(LC 6)

FORCES. (lb) - Max. Comp./Max. Ten. - All forces 250 (lb) or less except when shown.
 TOP CHORD C-D=-176/435

- NOTES-**
- 1) Wind: ASCE 7-05; 130mph; TCDL=6.0psf; BCDL=6.0psf; h=25ft; Cat. II; Exp C; enclosed; MWFRS (low-rise) and C-C Exterior(2) zone; cantilever left exposed ; end vertical left exposed; porch left exposed;C-C for members and forces & MWFRS for reactions shown; Lumber DOL=1.60 plate grip DOL=1.60
 - 2) This truss has been designed for basic load combinations, which include cases with reductions for multiple concurrent live loads.
 - 3) This truss has been designed for a 10.0 psf bottom chord live load nonconcurrent with any other live loads.
 - 4) * This truss has been designed for a live load of 20.0psf on the bottom chord in all areas where a rectangle 3-6-0 tall by 2-0-0 wide will fit between the bottom chord and any other members.
 - 5) Bearing at joint(s) D considers parallel to grain value using ANSI/TPI 1 angle to grain formula. Building designer should verify capacity of bearing surface.
 - 6) Provide mechanical connection (by others) of truss to bearing plate at joint(s) D.
 - 7) Provide mechanical connection (by others) of truss to bearing plate capable of withstanding 100 lb uplift at joint(s) except (jt=lb) B=279, D=263.
 - 8) This truss is designed in accordance with the 2009 International Residential Code sections R502.11.1 and R802.10.2 and referenced standard ANSI/TPI 1.
 - 9) This truss design requires that a minimum of 7/16" structural wood sheathing be applied directly to the top chord and 1/2" gypsum sheetrock be applied directly to the bottom chord.
 - 10) See Standard Industry Piggyback Truss Connection Detail for Connection to base truss as applicable, or consult qualified building designer.

LOAD CASE(S) Standard