

**NOTICE TO CONTRACTOR**  
 All construction must comply with current NC Building Codes and is subject to field inspection and verification.

**APPROVED**  
 Limited building only review  
 Permit holder responsible for full compliance with the code

09/25/2020



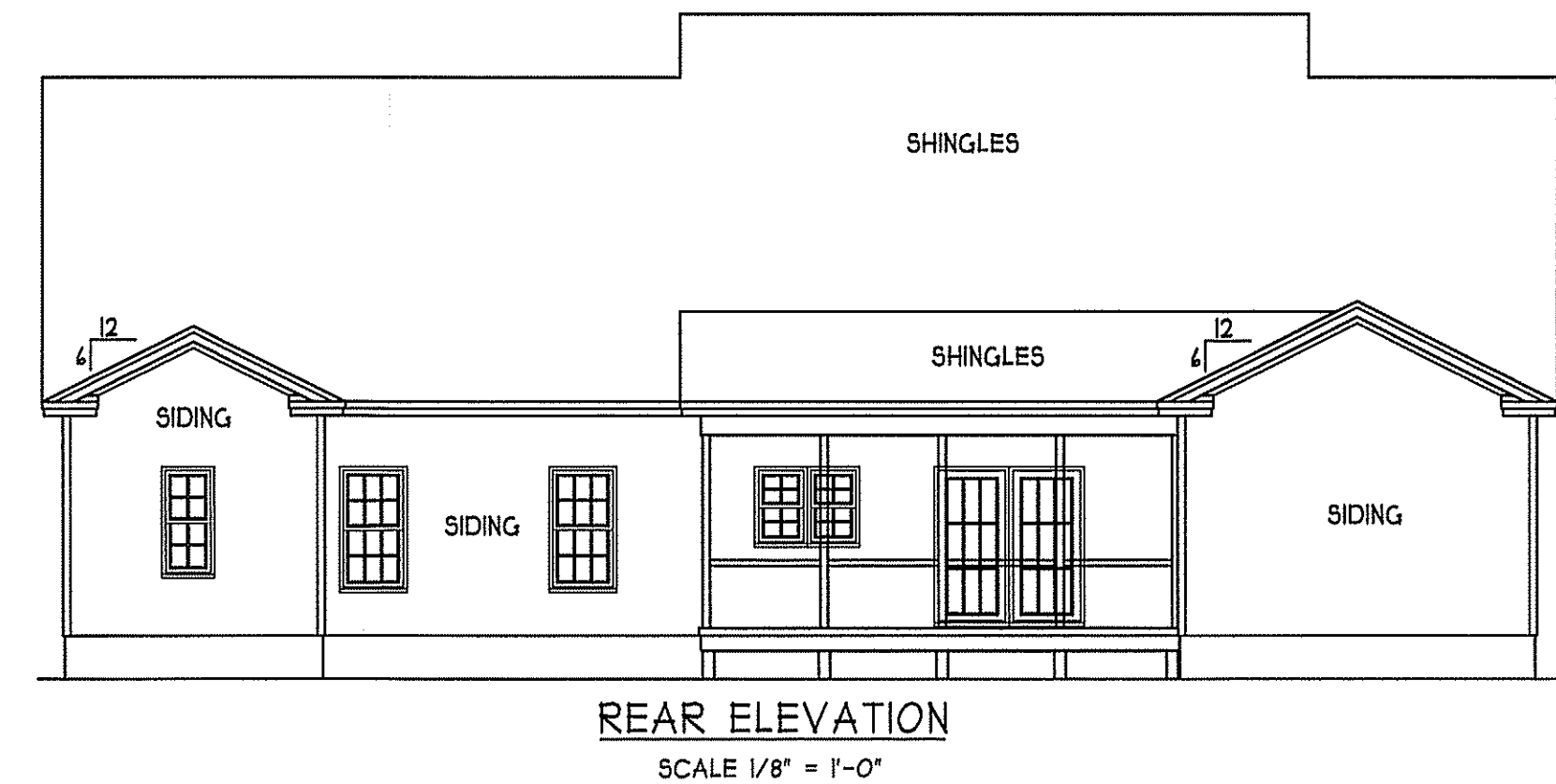

**ATTIC VENTILATION:**  
 THE NET FREE VENTILATING AREA SHALL BE NOT LESS THAN 1 TO 150 OF THE AREA OF THE SPACE VENTILATED EXCEPT THAT THE AREA MAY BE 1 TO 300 PROVIDED AT LEAST 50 PERCENT OF THE REQUIRED VENTILATING AREA IS PROVIDED BY VENTILATORS LOCATED IN THE UPPER PORTION OF THE SPACE TO BE VENTILATED AT LEAST 3 FEET ABOVE EAVE OR CORNICE VENTS WITH THE BALANCE OF THE REQUIRED VENTILATION TO BE PROVIDED BY EAVE OR CORNICE VENTS.

GROSS ATTIC AREA TO BE VENTILATED 2132 SQ.FT.  
 2132/150 = 19.55 SQ.FT. NET FREE AREA

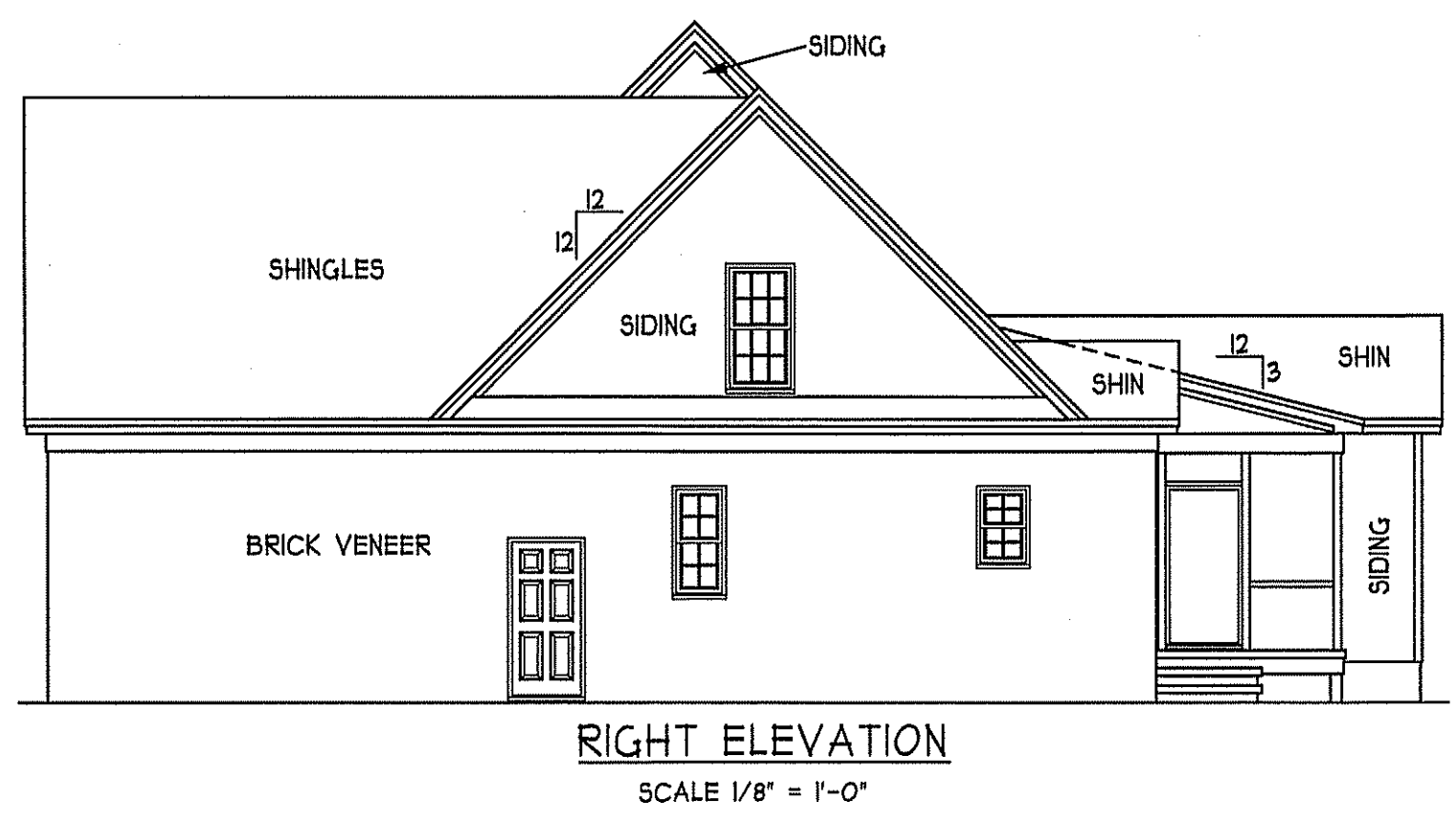
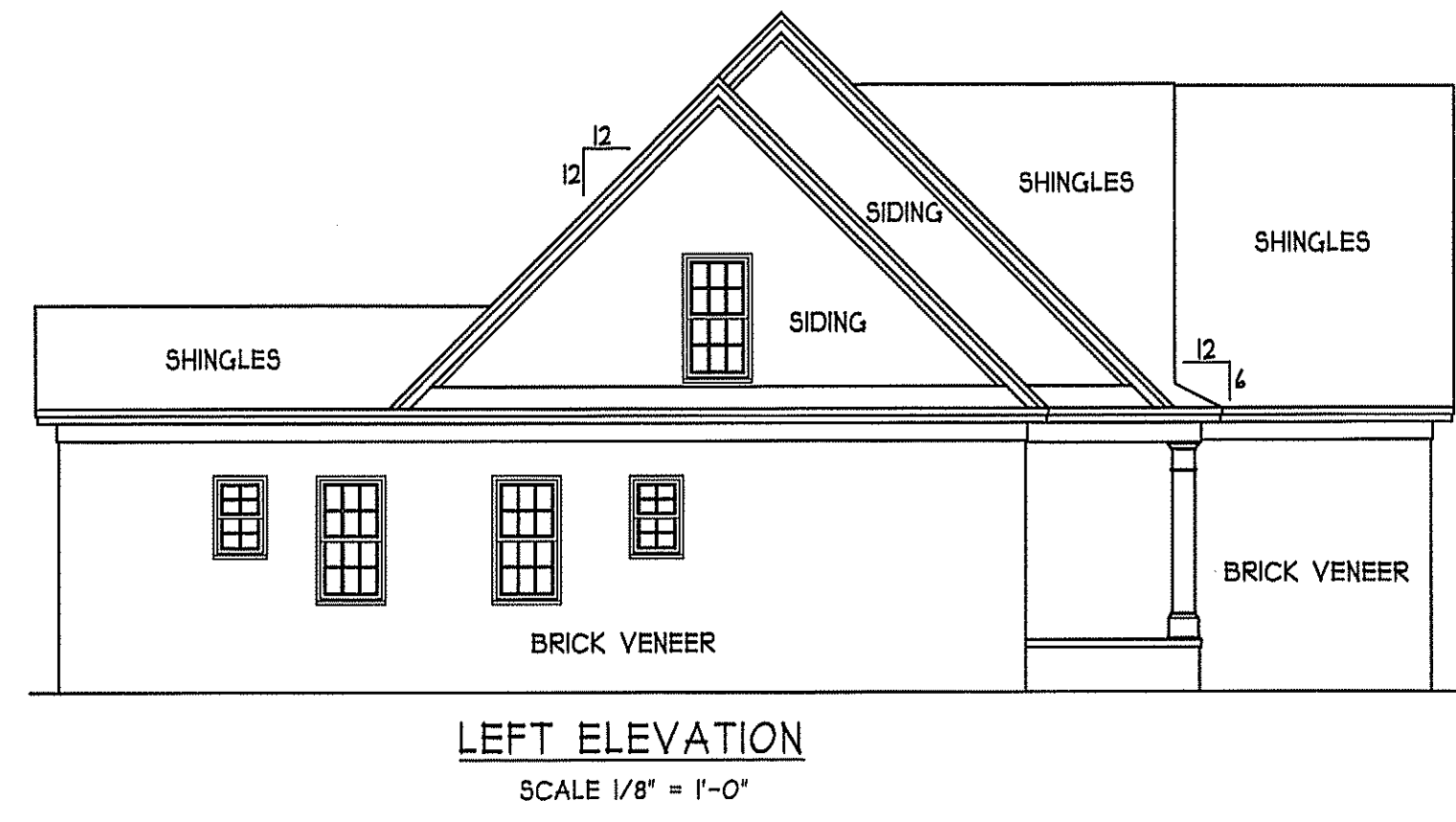

**ENERGY COMPLIANCE**  
 ZONE 3 = MAX. GLAZING U-FACTOR .35  
 R-VALUE = CEILING R38, WALLS R15  
 FLOORS R19 FOR JOHNSTON, WAYNE COUNTY  
 ZONE 4 = MAX. GLAZING U-FACTOR .35  
 R-VALUE = CEILING R38, WALLS R15  
 FLOORS R19 FOR WAKE, ORANGE COUNTY



**KIM BREEDEN & FERGIE ROPER**

**#2778**

HEATED FOOTAGE:

1825	1825
953	953
443	443
581	581

SQUARE FOOTAGE:

FIRST FLOOR	1825
SECOND FLOOR	953
COVERED PORCHES	443
DBL CAR GARAGE	581

DESIGNED BY: HEATHER HALL  
 165 HEATHERSTONE CT  
 BENSON NC 27504  
 (919) 207-1403

**H SQUARED HOME DESIGN, INC.**

**H**

ANY DEVIATION OF THIS PLAN, DIMENSIONS OR OTHERWISE H SQUARED HOME DESIGN, INC. IS NOT LIABLE.  
 THIS PLAN MAY BE USED FOR CONSTRUCTION IN ACCORDANCE WITH NORTH CAROLINA BUILDING CODES AND REGULATIONS.

DATE: 08/20/20

1 1/2 STORY

FILE: 030120

STRUCTURAL DESIGN BY:  
SOUTHERN ENGINEERS, P.A.  
3714 BENSON DR., RALEIGH, NC 27604  
LICENSE: C-1281, PHONE: 919-878-4471  
PROJECT #: 20-1102 (TRUSS)

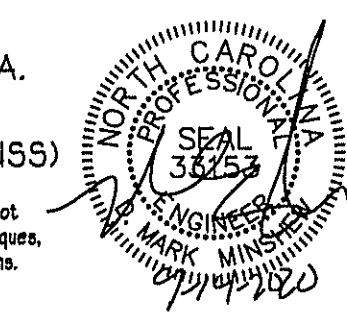

Engineer seal applies only to structural components on this document. Seal does not include construction means, methods, techniques, sequences, procedures or safety precautions. Any deviations or discrepancies on plans are to be brought to the immediate attention of Southern Engineers. Failure to do so will void Southern Engineer's liability. Seal is valid for a project permitted one year from date of seal. Use of these plans constitutes approval of terms & conditions as defined in the customer agreement.

REFER TO "SD" SHEET(S) FOR STANDARD DETAILS, BRACING DETAILS, AND STRUCTURAL NOTES

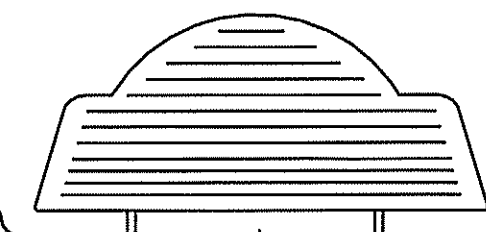

KIM BREEDEN  
& FERGIE ROPER

HEATED FOOTAGE:  
#2778

SQUARE FOOTAGE:  
FIRST FLOOR = 1825  
SECOND FLOOR = 953  
COVERED PORCHES = 443  
DBL CAR GARAGE = 581

DESIGNED BY:  
HEATHER HALL  
185 HEATHERSTONE CT  
BENSON NC 27504  
(919) 207-1403

H SQUARED  
HOME  
DESIGN, INC.

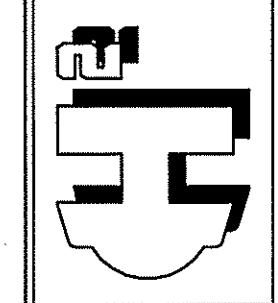

ANY DEVIATION OF THIS PLAN, DIMENSIONS OR OTHERWISE, H SQUARED HOME DESIGN, INC. IS NOT LIABLE.  
IN ACCORDANCE WITH NORTH CAROLINA CONTRACT DOCUMENTS

DATE:  
08/20/20

1 1/2 STORY

FILE:  
030120

DIMENSIONAL LUMBER ON THIS SHEET MAY BE SPP #2 OR SYP #2

**FOUNDATION STRUCTURAL NOTES:**

- NC (2018 NCRC); Wind: 115-120 MPH
- (1) 2x10 SYP #2 OR SPP#2 GIRDER, TYPICAL.
- (2) CONCRETE BLOCK PIER SIZE SHALL BE:  
SIZE HOLLOW MASONRY SOLID MASONRY  
8 x 16 UP TO 32" HIGH UP TO 5'-0" HIGH  
12 x 16 UP TO 48" HIGH UP TO 9'-0" HIGH  
16 x 16 UP TO 64" HIGH UP TO 12'-0" HIGH  
24 x 24 UP TO 96" HIGH UP TO 12'-0" HIGH  
WITH 30" x 30" x 10" CONCRETE FOOTING, UNO.
- (3) WALL FOOTING AS FOLLOWS:  
DEPTH: 8" - UP TO 2-1/2 STORY  
10" - 3 STORY  
WIDTH: SIDING (OR EQUAL)  
- 16" - UP TO 2-1/2 STORY  
- 20" - 3 STORY  
BRICK VENEER  
- 16" - 1 STORY  
- 20" - 2 STORY  
- 24" - 3 STORY
- FOR FOUNDATION WALL HEIGHT AND BACKFILL REQUIREMENTS, REFER TO NORTH CAROLINA RESIDENTIAL CODE TABLE R404.1.1 (I THRU 4)  
NOTE: ASSUMED SOIL BEARING CAPACITY = 2000 PSF.  
CONTRACTOR MUST VERIFY SITE CONDITIONS AND CONTACT SOILS ENGINEER IF MARGINAL OR UNSTABLE SOILS ARE ENCOUNTERED.
- (4) 2x10 SYP#2 OR SPP#2 GIRDER.
- (5) 2 L1.75X1.25 LVL OR LSL GIRDER
- (6) 1.75X1.25 LVL OR LSL GIRDER

7. "\*" DESIGNATES A SIGNIFICANT POINT LOAD TO HAVE SOLID BLOCKING TO PIER. SOLID BLOCK ALL BEAM BEARING POINTS NOTED TO HAVE THREE OR MORE STUDS TO FND, TYPICAL.

8. ABBREVIATIONS:  
"S" = SINGLE JOIST  
"D" = DOUBLE JOIST  
"T" = TRIPLE JOIST

F1 24"x16" SOLID FILLED, FLUSH MASONRY PIER ON A 48"x36"x12" CONC. FTG. REINFORCED WITH #5 BAR @ 1' O.C. (MIN. OF (5) BARS) IN THE LONG DIRECTION AND @ 4" O.C. (MIN. OF (1) BARS) IN THE SHORT DIRECTION.

F2 24"x16" MASONRY PIER ON A 36"x30"x10" CONC. FTG.

F3 16"x16" SOLID FILLED MASONRY PIER ON A 44"x44"x12" CONC. FTG. REINFORCED WITH #5 BAR @ 1' O.C. (MIN. OF (6) BARS) EACH WAY.

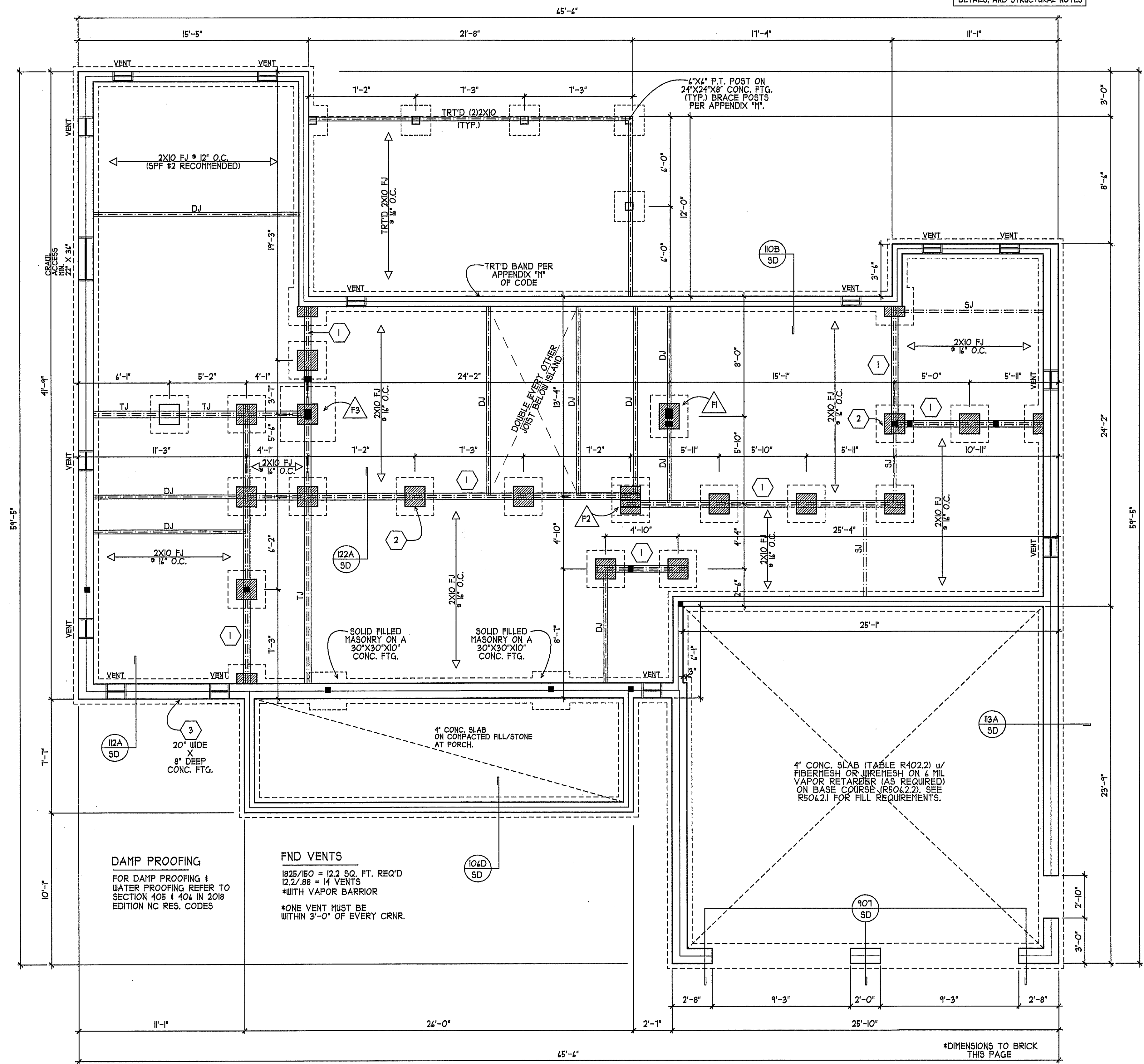

FOUNDATION PLAN  
SCALE 1/4" = 1'-0"

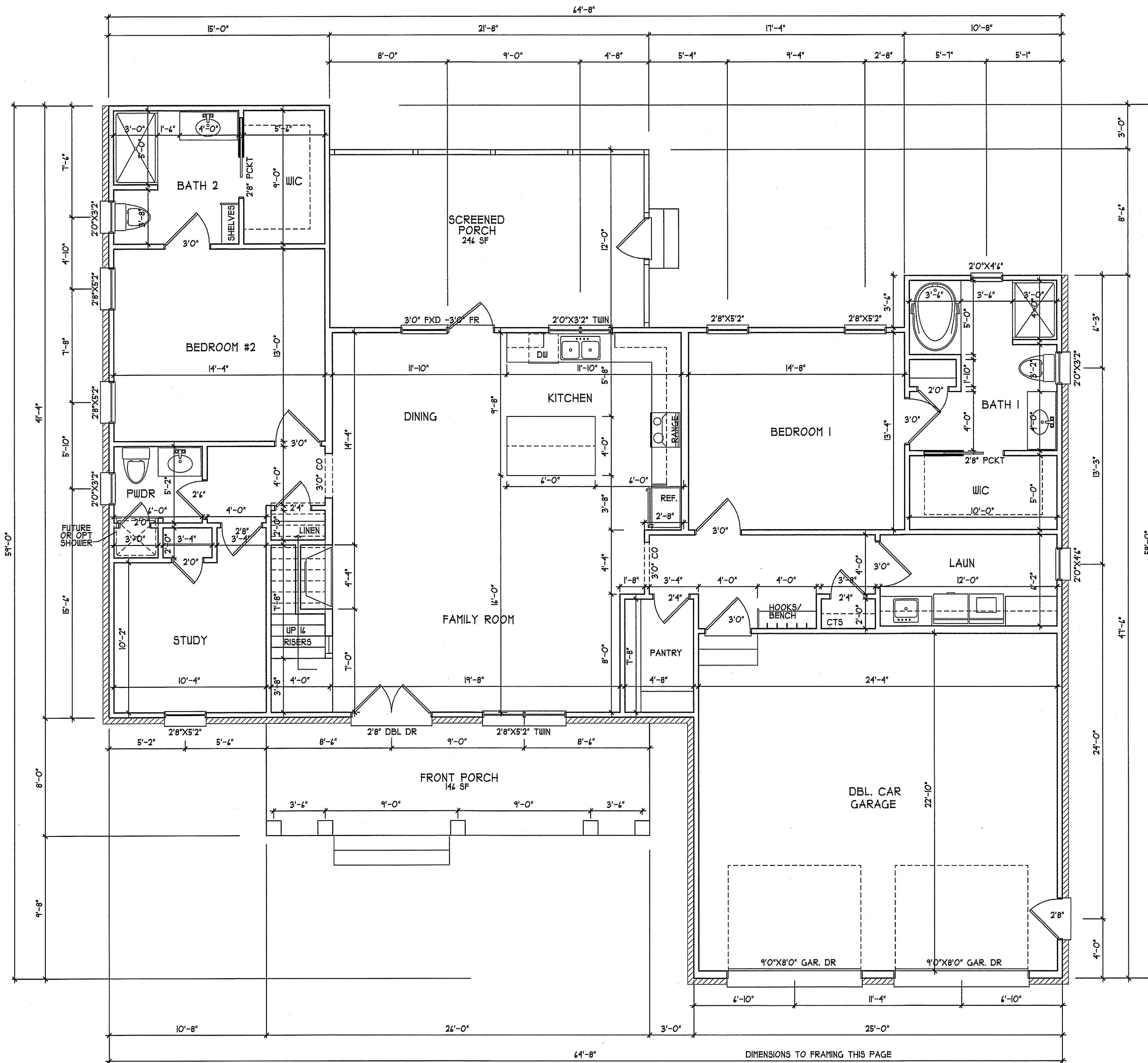

FIRST FLOOR PLAN  
SCALE 1/4" = 1'-0"

<b>H SQUARED HOME DESIGN, INC.</b>	
DESIGNED BY: HEATHER HALL 185 HEATHERSTONE CT BENSON NC 27504 (919) 207-1403	
#2778	
KIM BREEDEN & FERGIE ROPER	
HEATED FOOTAGE:	
= 1825 = 953 = 443 = 581	
SQUARE FOOTAGE: FIRST FLOOR SECOND FLOOR COVERED PORCHES DBL CAR GARAGE	
ANY DEVIATION OF THIS PLAN, DIMENSIONS OR OTHERWISE, H SQUARED HOME DESIGN, INC. IS NOT LIABLE. <small>THIS PLAN HAS BEEN PREPARED IN ACCORDANCE WITH THE PROFESSIONAL ENGINEERING ACT AND THE PROFESSIONAL ARCHITECTURE ACT OF THE STATE OF NORTH CAROLINA.</small>	
DATE: 08/20/20	
1 1/2 STORY	
FILE: 030120	

STRUCTURAL DESIGN BY:  
SOUTHERN ENGINEERS, P.A.  
374 BENSON DR., RALEIGH, NC 27604  
LICENSE: C-1281, PHONE: 919-816-1411  
PROJECT #: 20-1102 (TRUSS)

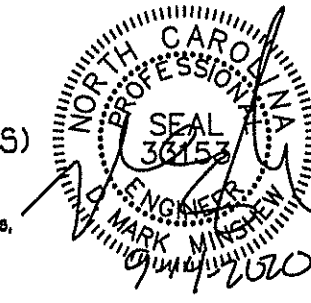

Engineers seal applies only to structural components on this document. Seal does not include construction means, methods, techniques, sequences, procedures or safety precautions.  
Any deviations or discrepancies on plans are to be brought to the immediate attention of Southern Engineers. Failure to do so will void Southern Engineer's liability.  
Seal is valid for a project permitted one year from date of seal.  
Use of these plans constitutes approval of terms & conditions as defined in the customer agreement.

REFER TO "SD" SHEET(S) FOR STANDARD DETAILS, BRACING DETAILS, AND STRUCTURAL NOTES

**PORCH POST NOTES:**

- 4"x4" TRT'D POST (OR EQUAL).
  - ATTACH TRUSSES (RAFTERS) AT PORCH WITH HURRICANE CONNECTORS.
1. POST CAP: SIMPSON AC4-MAX (AC4-MAX)
  2. POST CAP AT CORNER: (2) SIMPSON LCE4 (MITER HEADER AT CORNER). HIGH WIND: ADD (1) SIMPSON H4.
  3. POST BASE: SIMPSON ABU44 (ABU44)
    - (3) HONO: 5/8" ANCHOR (EMBED 1")
    - (2) CUI: 3/8" ANCHOR (EXTEND TO FOOTING - HIGH WIND ONLY)
  4. POST BASE: WOOD FOUNDATION: (2) SIMPSON CS4 STRAPS AT POSTS. EXTEND 12" ONTO EACH POST (UPPER AND LOWER) OR TO GIRDER.
- NOTE: EQUIVALENT POST CAP AND BASE ACCEPTABLE.

**HEADER/BEAM & COLUMN NOTES**

1. ALL EXTERIOR AND LOAD BEARING HEADERS SHALL BE MIN. (2) 2"x4" (4" WALL) OR (3) 2"x4" (4" WALL) WITH (1) SUPPORT STUD, UNLESS NOTED OTHERWISE.
2. THE NUMBER SHOWN AT BEAM AND HEADER SUPPORTS INDICATES THE NUMBER OF SUPPORT STUDS REQUIRED IN STUD POCKET AT EACH END OF HEADERS IN EXTERIOR WALLS. SHALL BE ACCORDING TO ITEM "d" IN TABLE R4(2.3.6) OR AS BELOW:
  - UP TO 4' SPAN: (1) KING STUD
  - OVER 4' UP TO 8' SPAN: (2) KING STUDS
  - OVER 8' UP TO 11' SPAN: (3) KING STUDS
  - OVER 11' SPAN: (4) KING STUDS

**TRUSS SYSTEM REQUIREMENTS**

- NC (2018 NCR): Wind: 115-120 mph
1. TRUSS SYSTEM LAYOUTS (PLACEMENT PLANS) SHALL BE DESIGNED IN ACCORDANCE WITH SEALED STRUCTURAL PLANS. ANY NEED TO CHANGE TRUSSES SHALL BE COORDINATED WITH SOUTHERN ENGINEERS.
  2. TRUSS SCHEMATICS (PROFILES) SHALL BE PREPARED AND SEALED BY TRUSS MANUFACTURER.
  3. ALL TRUSSES SHALL BE DESIGNED FOR BEARING ON SPF #2 OR #3 PLATES OR LEDGERS (UNO).
  4. ALL REQUIRED ANCHORS FOR TRUSSES DUE TO UPLIFT OR BEARING SHALL MEET THE REQUIREMENTS AS SPECIFIED ON THE TRUSS SCHEMATICS.

**FRAMING NOTES**

- NC (2018 NCR): Wind: 115-120 mph
1. BRACING METHOD AND TYPE: CONTINUOUSLY SHEATHED WSP. CS-WSP. NOTE THAT THE WALL BRACING AMOUNT PROVIDED ON THE PLANS (DETAILS AND SPECIFICATIONS) IS GREATER THAN THE AMOUNT OF WALL BRACING REQUIRED BY THE CODE. SEE NOTES BELOW FOR DETAILS AND SPECIFICATIONS FOR WALL BRACING AND WALL FRAMING.
  2. EXTERIOR WALL SHEATHING: WALLS SHALL BE BRACED BY SHEATHING WALLS ON ALL STORIES WITH WOOD STRUCTURAL PANEL SHEATHING (WSP) (EXPOSURE B: 1/4", EXPOSURE C: 5/32"). SHEATHING SHALL BE ATTACHED WITH 8d NAILS AT A 4"/12" NAILING PATTERN (4" O.C. AT PANEL EDGES AND 12" O.C. AT INTERMEDIATE SUPPORTS). INSTALL BLOCKING AT ALL PANEL EDGES.
  3. WSP SHEATHING SHALL EXTEND TO THE UPPERMOST DOUBLE BEARING PLATE BLOCK AT ROOF AND ATTACH BRACED WALLS PER CODE. WSP SHEATHING BETWEEN FLOORS SHALL BE SPICED ACROSS STUDS (CONTINUOUS ACROSS FLOOR SYSTEM) WITH BLOCKING AT PANEL EDGES. MINIMUM 12" BEYOND FLOOR BREAK) OR OTHER APPROVED METHOD.
  4. "HD" = HOLD-DOWN; HOLD-DOWN DEVICE (NOTED AS "HD" ON PLANS) SHALL BE AN 800 POUND CAPACITY ASSEMBLY AS NOTED ON PLANS. SEE DETAILS FOR HD ASSEMBLY.
    - \*\*GROUND/FIRST FLOOR: USE "HD HOLD-DOWN DETAIL" ON SD SHEET (OR EQUAL).
    - \*\*UPPER FLOORS: ATTACH BASE OF KING STUD WITH A SIMPSON CS22 STRAP DOWN ACROSS THE BAND AND DOWN TO A STUD BELOW OR HEADER BELOW. EXTEND STRAP 1" MIN ALONG EACH STUD (OR HEADER) AND ATTACH EACH END W/ (1) 8d NAILS.
  5. INTERIOR BRACED WALL: (NOTED AS "IBW" ON PLANS) ATTACH 1/2" GYPSUM BOARD (GB) ON EACH SIDE OF WALL WITH A MIN. OF 8d COOLER NAILS OR #4 SCREWS @ 1' O.C. ALONG THE EDGES AND AT INTERMEDIATE SUPPORTS.
  6. INTERIOR BRACED WALL-WOOD STRUCTURAL PANEL: (NOTED AS "IBW-WSP" ON PLANS). ATTACH ONE SIDE WITH 7/16" WSP SHEATHING WITH 8d NAILS AT A 4"/12" NAILING PATTERN (4" O.C. AT PANEL EDGES AND 12" O.C. AT INTERMEDIATE SUPPORTS). INSTALL BLOCKING AT ALL PANEL EDGES. ATTACH GB OVER WSP REQUIRED. ATTACH OPPOSITE SIDE WITH 1/2" GB WITH A MIN. OF 8d COOLER NAILS OR #4 SCREWS @ 1' O.C. ALONG THE EDGES AND AT INTERMEDIATE SUPPORTS.

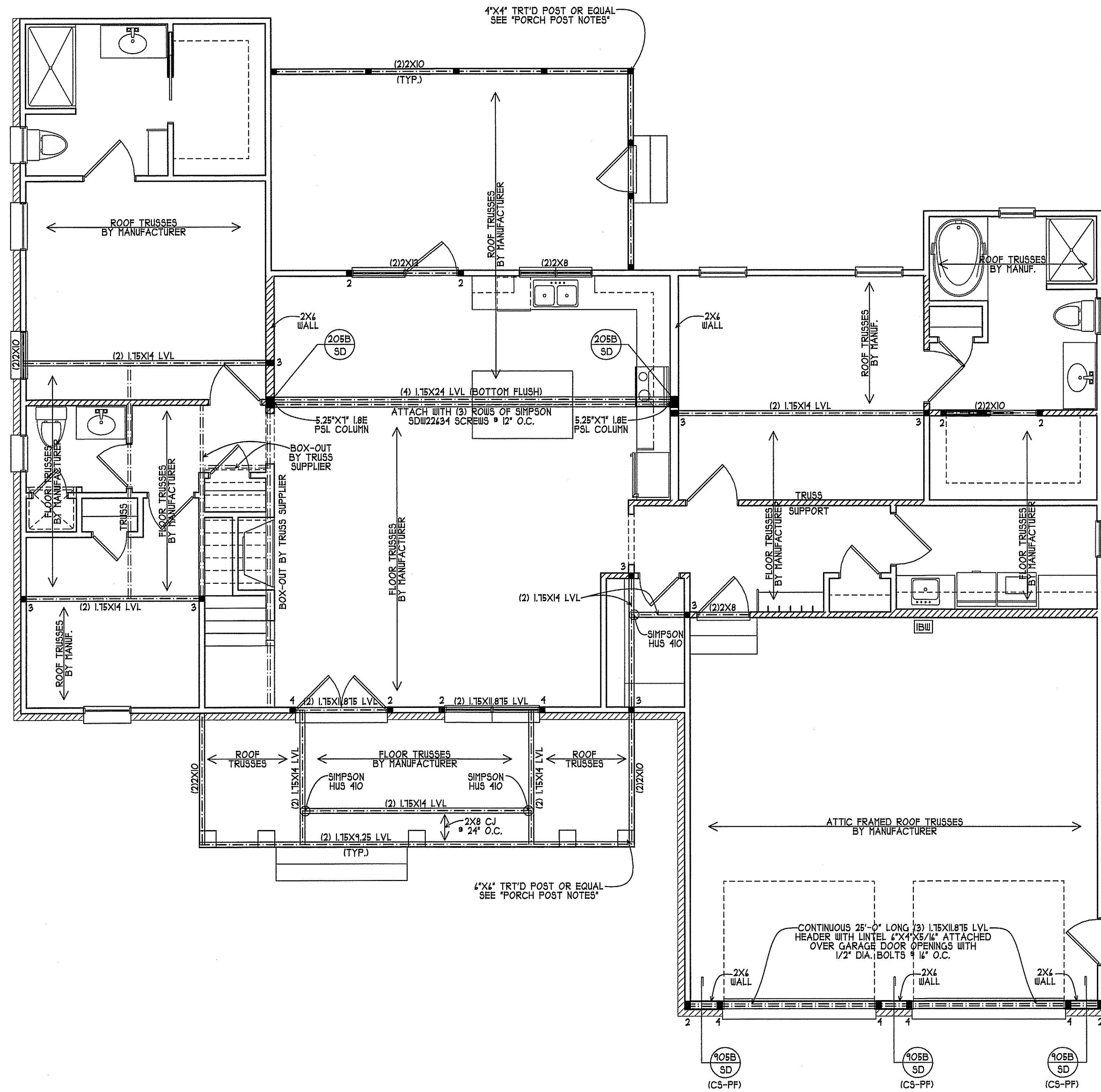

FIRST FLOOR PLAN  
SCALE 1/4" = 1'-0"

	<b>H SQUARED HOME DESIGN, INC.</b>	DESIGNED BY: HEATHER HALL 165 HEATHERSTONE CT BENSON NC 27504 (919) 207-1403	HEATED FOOTAGE:  #2778	KIM BREEDEN & FERGIE ROPER	
ANY DEVIATION OF THIS PLAN DIMENSIONS OR OTHERWISE, H SQUARED HOME DESIGN, INC. IS NOT LIABLE. <small>THE PLAN HAS BEEN REVIEWED BY AN ENGINEER AND APPROVED FOR CONSTRUCTION.</small>		DATE: 08/20/20		1 1/2 STORY	
FILE: 030120		SQUARE FOOTAGE: FIRST FLOOR = 1825 SECOND FLOOR = 853 COVERED PORCHES = 443 DBL CAR GARAGE = 591		REFER TO "SD" SHEET(S) FOR STANDARD DETAILS, BRACING DETAILS, AND STRUCTURAL NOTES	

STRUCTURAL DESIGN BY:  
SOUTHERN ENGINEERS, P.A.  
374 BENSON DR., RALEIGH, NC 27604  
LICENSE: C-1281, PHONE: 919-878-4411  
PROJECT #: 20-1102 (TRUSS)

\* Engineer's seal applies only to structural components on this document. Seal does not include construction means, methods, techniques, sequences, procedures or safety precautions.  
\* Any deviations or discrepancies on plans are to be brought to the immediate attention of Southern Engineers. Failure to do so will void Southern Engineer's liability.  
\* Seal is valid for a project permitted one year from date of seal.  
\* Use of these plans constitutes approval of terms & conditions as defined in the customer agreement.

REFER TO "SD" SHEET(S) FOR STANDARD DETAILS, BRACING DETAILS, AND STRUCTURAL NOTES

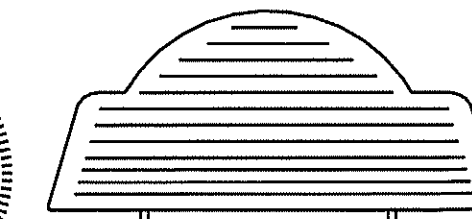
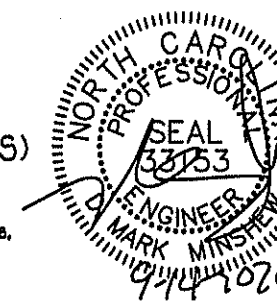

KIM BREIDEN  
& FERGIE ROPER

HEATED FOOTAGE:  
#2778

SQUARE FOOTAGE:  
= 1825  
= 953

FIRST FLOOR  
SECOND FLOOR  
COVERED PORCHES  
DBL CAR GARAGE

DESIGNED BY:  
HEATHER HALL  
185 HEATHERSTONE CT  
BENSON NC 27504  
(919) 207-1403

H SQUARED HOME DESIGN, INC.

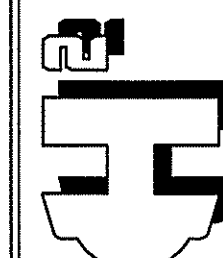

ANY DEVIATION OF THIS PLAN, DIMENSIONS OR OTHERWISE, H SQUARED HOME DESIGN, INC. IS NOT LIABLE.  
THIS PLAN HAS BEEN DRAWN BY AN ARCHITECT REGISTERED IN THE STATE OF NORTH CAROLINA UNDER LICENSE NO. 2008-0008

DATE:  
08/20/20

1 1/2 STORY

FILE:  
030120

HEADER/BEAM & COLUMN NOTES

1. ALL EXTERIOR AND LOAD BEARING HEADERS SHALL BE MIN. (2) 2x4 (4" WALL) OR (3) 2x4 (2" WALL) WITH (1) SUPPORT STUD, UNLESS NOTED OTHERWISE.

2. THE NUMBER SHOWN AT BEAM AND HEADER SUPPORTS INDICATES THE NUMBER OF SUPPORT STUDS REQUIRED IN STUD POCKET OR COLUMN. THE NUMBER OF KING STUDS AT EACH END OF HEADERS IN EXTERIOR WALLS SHALL BE ACCORDING TO ITEM "d" IN TABLE R402.3(5) OR AS BELOW:

- UP TO 4' SPAN: (1) KING STUD
- OVER 4' UP TO 8' SPAN: (2) KING STUDS
- OVER 8' UP TO 11' SPAN: (3) KING STUDS
- OVER 11' SPAN: (4) KING STUDS

TRUSS SYSTEM REQUIREMENTS

NC (2018 NCRC): Wind: 115-120 mph

1. TRUSS SYSTEM LAYOUTS (PLACEMENT PLANS) SHALL BE DESIGNED IN ACCORDANCE WITH SEALED STRUCTURAL PLANS. ANY NEED TO CHANGE TRUSSES SHALL BE COORDINATED WITH SOUTHERN ENGINEERS.

2. TRUSS SCHEMATICS (PROFILES) SHALL BE PREPARED AND SEALED BY TRUSS MANUFACTURER.

3. ALL TRUSSES SHALL BE DESIGNED FOR BEARING ON SPF #2 OR #3 PLATES OR LEDGERS (UNO).

4. ALL REQUIRED ANCHORS FOR TRUSSES DUE TO UPLIFT OR BEARING SHALL MEET THE REQUIREMENTS AS SPECIFIED ON THE TRUSS SCHEMATICS.

FRAMING NOTES

NC (2018 NCRC): Wind: 115-120 mph

1. BRACING METHOD AND TYPE: CONTINUOUSLY SHEATHED WSP. CS-WSP. NOTE THAT THE WALL BRACING AMOUNT PROVIDED ON THE PLANS (DETAILS AND SPECIFICATIONS) IS GREATER THAN THE AMOUNT OF WALL BRACING REQUIRED BY THE CODE. SEE NOTES BELOW FOR DETAILS AND SPECIFICATIONS FOR WALL BRACING AND WALL FRAMING.

2. EXTERIOR WALL SHEATHING: WALLS SHALL BE BRACED BY SHEATHING WALLS ON ALL STORIES WITH WOOD STRUCTURAL PANEL SHEATHING (WSP) (EXPOSURE B: 1/4" EXPOSURE C: 1/2"). SHEATHING SHALL BE ATTACHED WITH 8d NAILS AT A 4"/12" NAILING PATTERN (4" O.C. AT PANEL EDGES AND 12" O.C. AT INTERMEDIATE SUPPORTS). INSTALL BLOCKING AT ALL PANEL EDGES.

3. WSP SHEATHING SHALL EXTEND TO THE UPPERMOST DOUBLE BEARING PLATE BLOCK AT ROOF AND ATTACH BRACED WALLS PER CODE. WSP SHEATHING BETWEEN FLOORS SHALL BE SPICED ACROSS STUDS (CONTINUOUS ACROSS FLOOR SYSTEM) WITH BLOCKING AT PANEL EDGES. MINIMUM 12" BEYOND FLOOR BREAK OR OTHER APPROVED METHOD.

4. "HD" = HOLD-DOWN: HOLD-DOWN DEVICE (NOTED AS "HD" ON PLANS) SHALL BE AN 800 POUND CAPACITY ASSEMBLY AS NOTED ON PLANS. SEE DETAILS FOR HD ASSEMBLY.  
\*\*GROUND/FIRST FLOOR: USE "HD HOLD-DOWN DETAIL" ON SD SHEET (OR EQUIV).  
\*\*UPPER FLOORS: ATTACH BASE OF KING STUD WITH A SIMPSON CS22 STRAP DOWN ACROSS THE BAND AND DOWN TO A STUD BELOW OR HEADER BELOW. EXTEND STRAP 1 MIN ALONG EACH STUD (OR HEADER) AND ATTACH EACH END W/ (1) 8d NAILS.

5. INTERIOR BRACED WALL: (NOTED AS "IBW" ON PLANS) ATTACH 1/2" GYPSUM BOARD (GB) ON EACH SIDE OF WALL WITH A MIN. OF 5d COOLER NAILS OR #4 SCREWS @ 1' O.C. ALONG THE EDGES AND AT INTERMEDIATE SUPPORTS.

6. INTERIOR BRACED WALL-WOOD STRUCTURAL PANEL: (NOTED AS "IBW-WSP" ON PLANS). ATTACH ONE SIDE WITH 1/4" WSP SHEATHING WITH 8d NAILS AT A 4"/12" NAILING PATTERN (4" O.C. AT PANEL EDGES AND 12" O.C. AT INTERMEDIATE SUPPORTS). INSTALL BLOCKING AT ALL PANEL EDGES. ATTACH GB OVER WSP REQUIRED. ATTACH OPPOSITE SIDE WITH 1/2" GB WITH A MIN. OF 5d COOLER NAILS OR #4 SCREWS @ 1' O.C. ALONG THE EDGES AND AT INTERMEDIATE SUPPORTS.

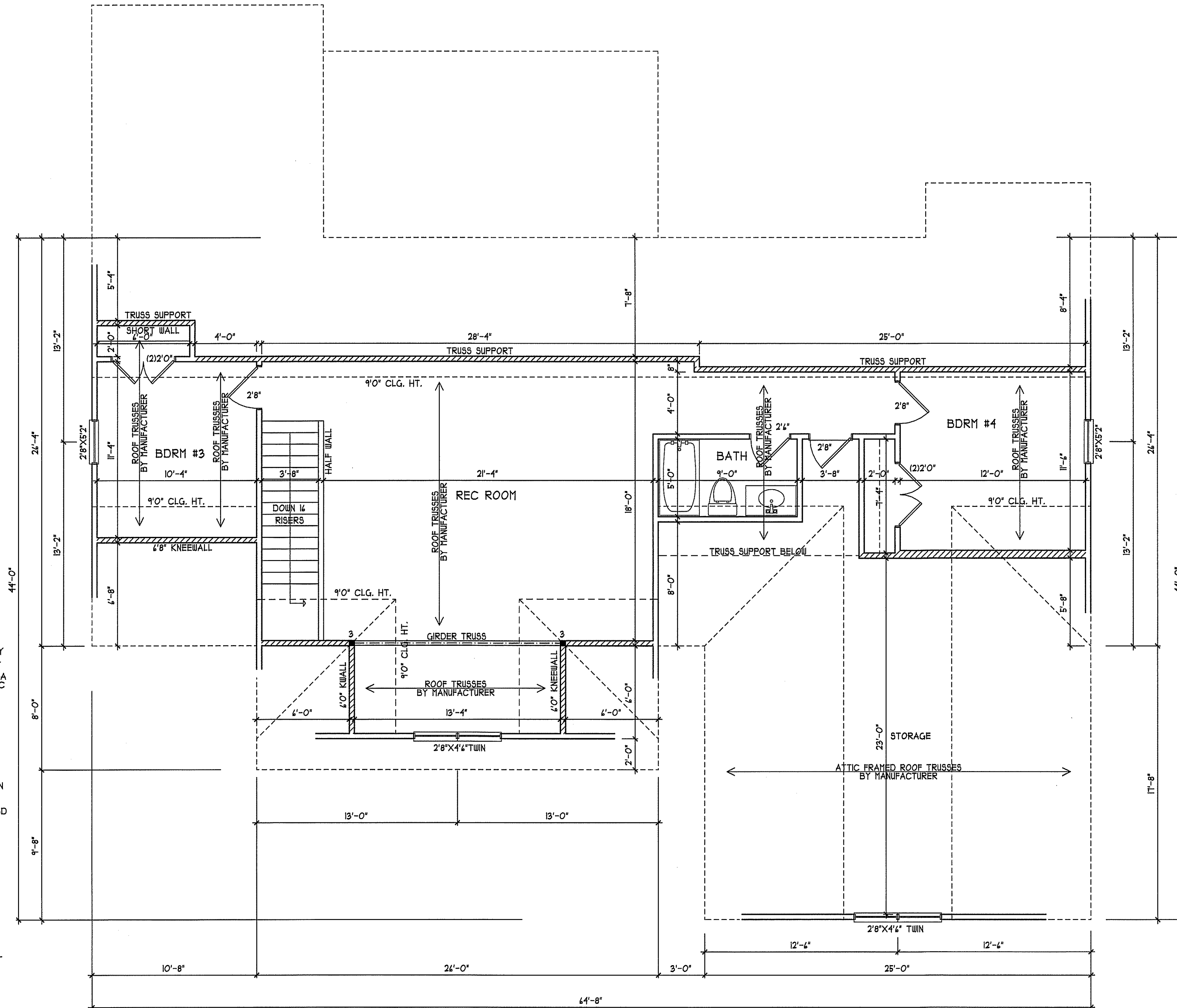

SECOND FLOOR PLAN  
SCALE 1/4" = 1'-0"

STRUCTURAL DESIGN BY:  
SOUTHERN ENGINEERS, P.A.  
374 BENSON DR., RALEIGH, NC 27609  
LICENSE: C-1281, PHONE: 919-878-1411  
PROJECT #: 20-1102 (TRUSS)

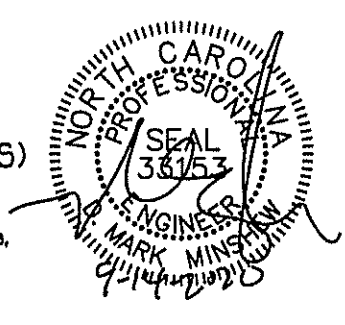

Engineer seal applies only to structural components on this document. Seal does not include construction means, methods, techniques, sequences, procedures or safety precautions. Any deviations or discrepancies on plans are to be brought to the immediate attention of Southern Engineers. Failure to do so will void Southern Engineer's liability. Seal is valid for a project permitted one year from date of seal. Use of these plans constitutes approval of terms & conditions as defined in the customer agreement.

REFER TO "SD" SHEETS FOR STANDARD DETAILS, BRACING DETAILS, AND STRUCTURAL NOTES

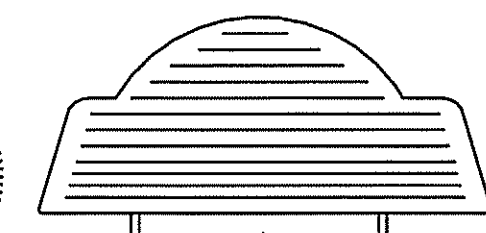

KIM BREEDEN  
& FERGIE ROPER

HEATED FOOTAGE:  
#2778

SQUARE FOOTAGE:  
FIRST FLOOR = 1825  
SECOND FLOOR = 953  
COVERED PORCHES = 443  
DBL CAR GARAGE = 581

DESIGNED BY:  
HEATHER HALL  
185 HEATHERSTONE CT  
BENSON NC 27504  
(919) 207-1403

H SQUARED HOME DESIGN, INC.

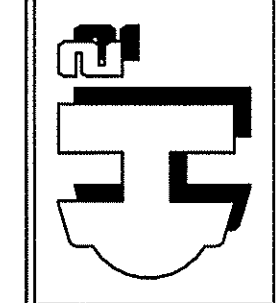

ANY DEVIATION OF THIS PLAN, DIMENSIONS OR OTHERWISE, H SQUARED HOME DESIGN, INC. IS NOT LIABLE.  
IN ACCORDANCE WITH NORTH CAROLINA RESIDENTIAL BUILDING CODE AND SECTION

DATE:  
08/20/20

1 1/2 STORY

FILE:  
030120

**TRUSS SYSTEM REQUIREMENTS**

- NC (2018 NCRC): Wind: 115-120 mph
1. TRUSS SYSTEM LAYOUTS (PLACEMENT PLANS) SHALL BE DESIGNED IN ACCORDANCE WITH SEALED STRUCTURAL PLANS. ANY NEED TO CHANGE TRUSSES SHALL BE COORDINATED WITH SOUTHERN ENGINEERS.
2. TRUSS SCHEMATICS (PROFILES) SHALL BE PREPARED AND SEALED BY TRUSS MANUFACTURER.
3. ALL TRUSSES SHALL BE DESIGNED FOR BEARING ON SPF #2 OR #3 PLATES OR LEDGERS (UNO).
4. ALL REQUIRED ANCHORS FOR TRUSSES DUE TO UPLIFT OR BEARING SHALL MEET THE REQUIREMENTS AS SPECIFIED ON THE TRUSS SCHEMATICS.

**ROOF FRAMING NOTES:**

- NC (2018 NCRC): Wind: 115-120 MPH
- 2x8 RAFTERS @ 16" O.C. WITH 2x10 RIDGE, UNO.
  - (2) 2x10 OR 1.75x11.875 LVL HIP. (2) 2x10 HIPS MAY BE SPLICED WITH A MIN. 6'-0" OVERLAP AT CENTER
  - (2) 2x10 OR 1.75x11.25 LVL VALLEY. DO NOT SPLICE VALLEYS
  - 1.75x11.875 LVL OR (2) 1.75x11.25 LVL VALLEY.
  - FALSE FRAME VALLEY ON 2x10 FLAT PLATE
  - 2x6 RAFTERS @ 24" O.C. W/ 2x8 RIDGE, UNO.
  - 2x10 RAFTERS @ 16" O.C. W/ 2x12 RIDGE, UNO.
  - EXTEND RIDGE 12" BEYOND INTERSECTION
- "SR" = SINGLE RAFTER
  - "DR" = DOUBLE RAFTER
  - "TR" = TRIPLE RAFTER
  - "RS" = ROOF SUPPORT
  - "■" = (3) STUD OR 4x4 POST FOR ROOF SUPPORT (USE 2x4 OR 4x4 FOR SUPPORT POSTS OVER 10'-0" IN HEIGHT)
- ATTACH VAULTED RAFTERS WITH HURRICANE CLIPS. SIMPSON "H2.5A" OR EQUIVALENT. TIES TO BE INSTALLED ON THE OUTSIDE FACE FRAMING.
- INSTALL RAFTER TIES AND COLLAR TIES PER SECTION R802.3.1 OF THE 2018 NC RESIDENTIAL CODE

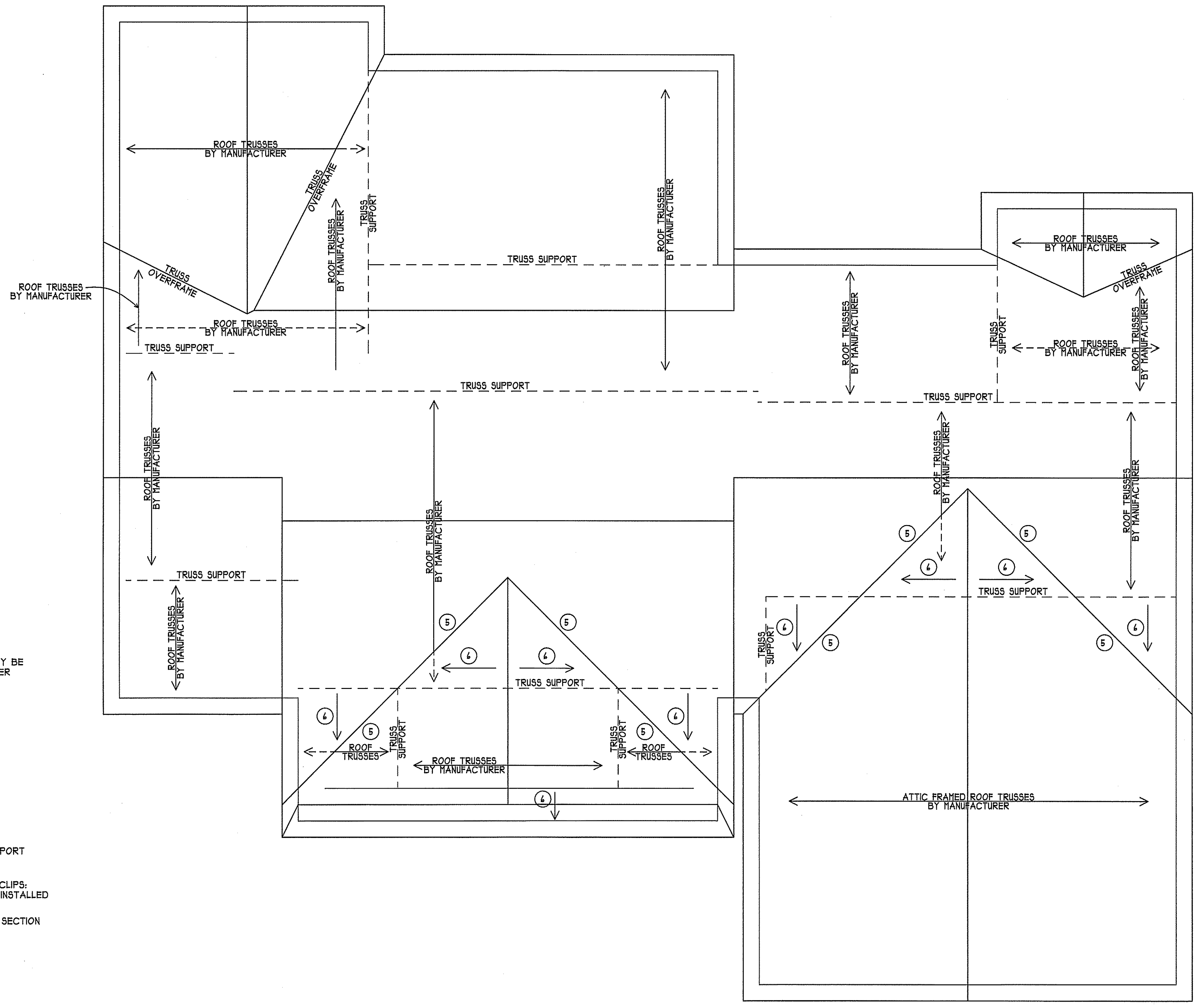

ROOF PLAN  
SCALE 1/4" = 1'-0"

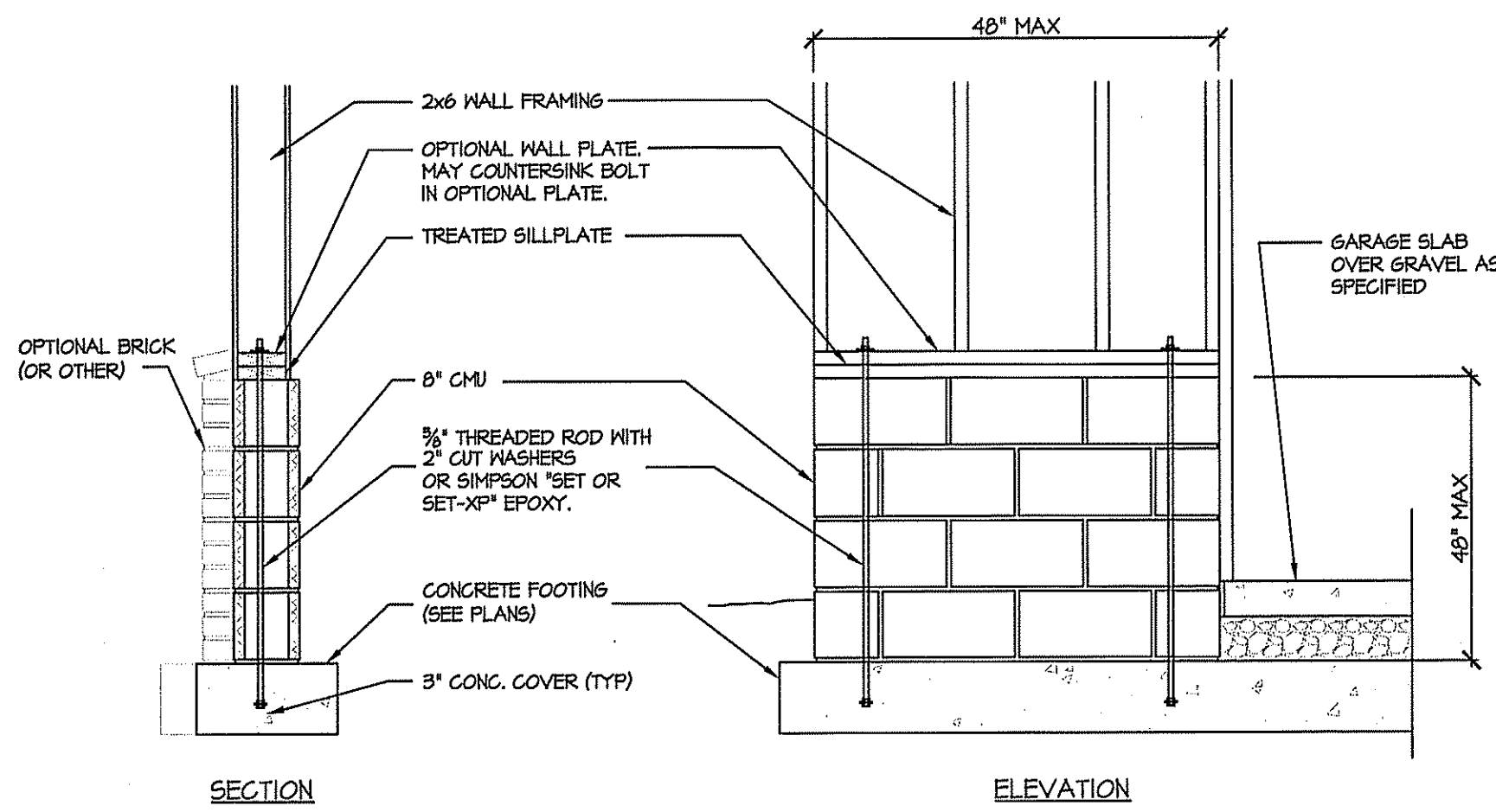

90T SD GARAGE 'WING WALL' REINFORCING PER IRC FIGURE R602.10.4.3

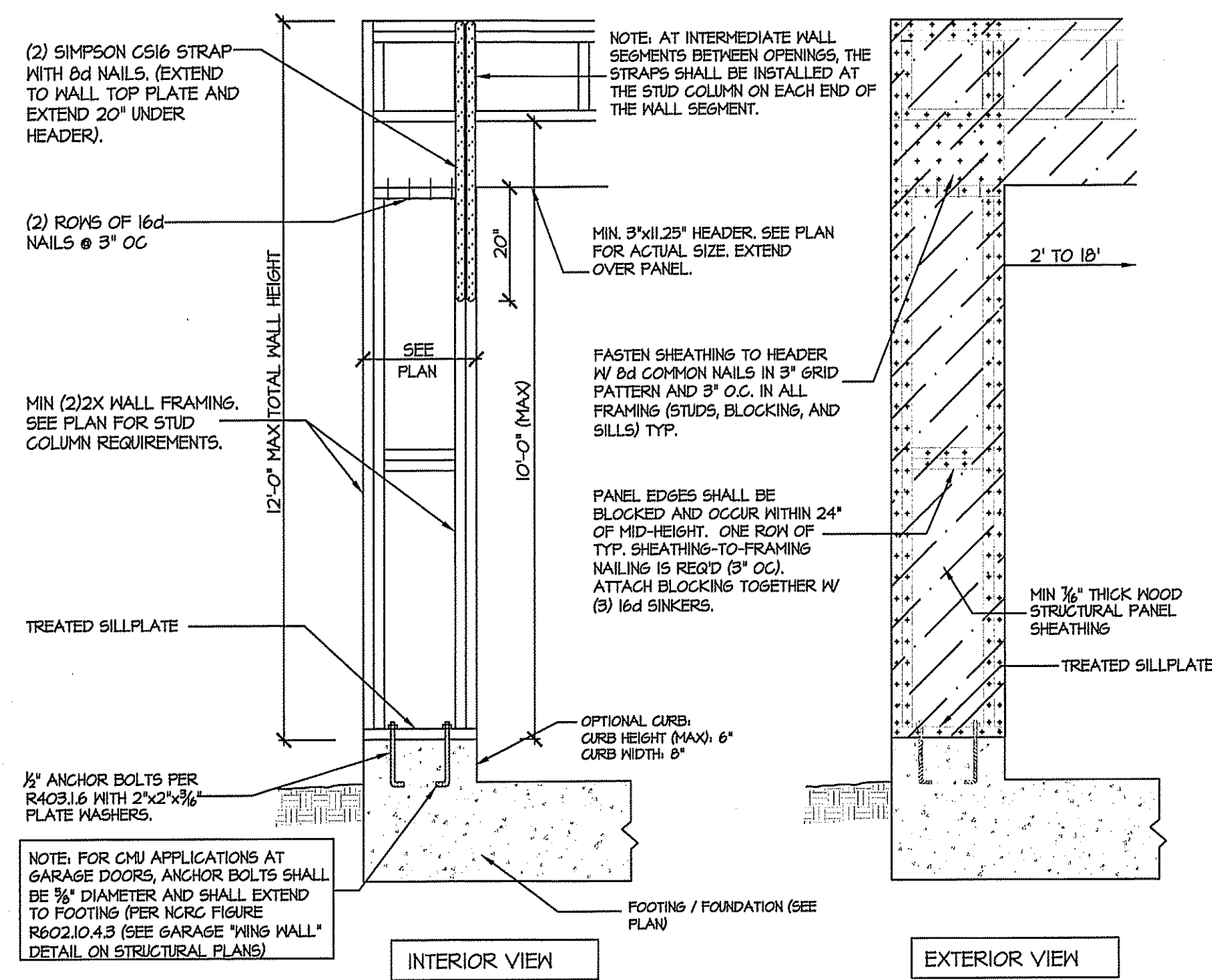

90BB SD CS-PF: CONTINUOUS PORTAL FRAME CONSTRUCTION DETAIL AND APPLICATION BASED ON NRC FIGURE R602.10.1 - PORTAL FRAME CONSTRUCTION

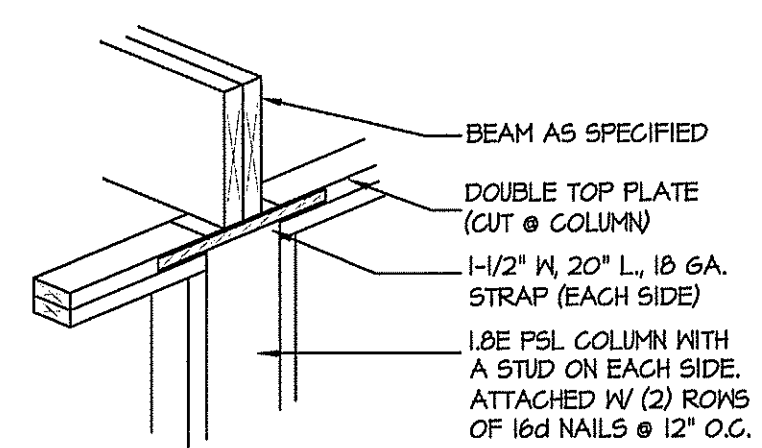

205B SD DIRECT BEAM BEARING NTS

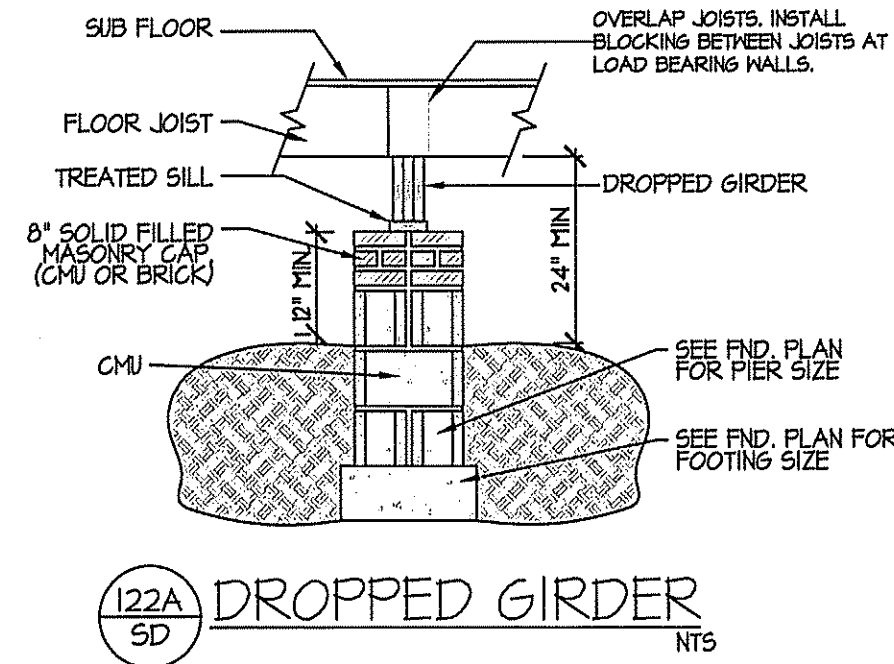

122A SD DROPPED GIRDER NTS

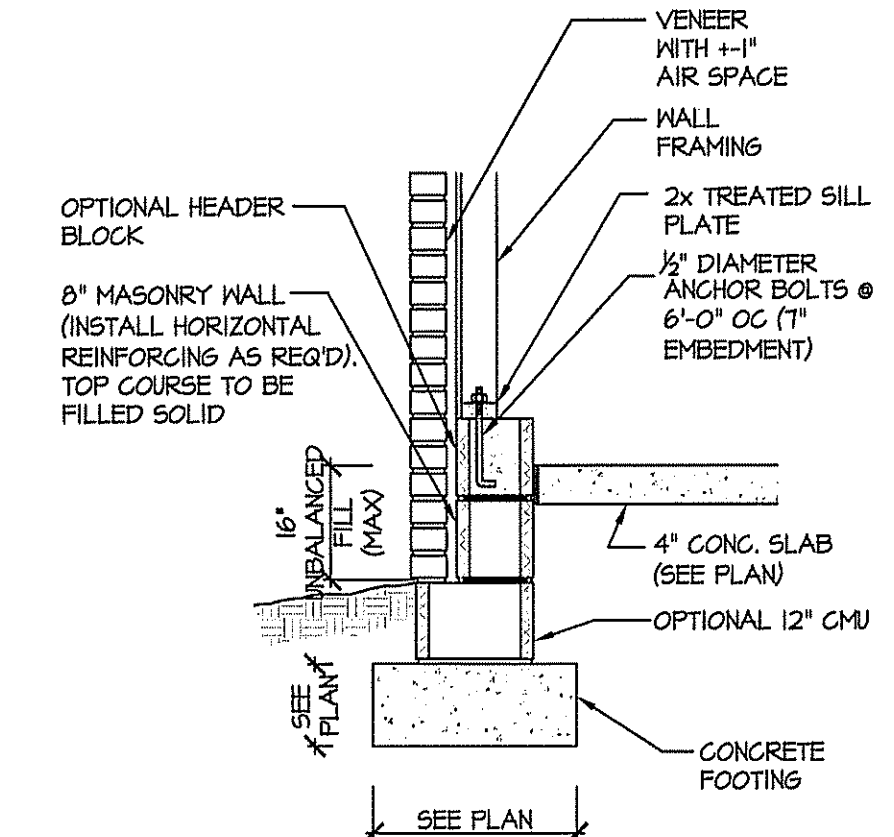

115-120 MPH 118A SD GARAGE WALL FOOTING (VENEER)

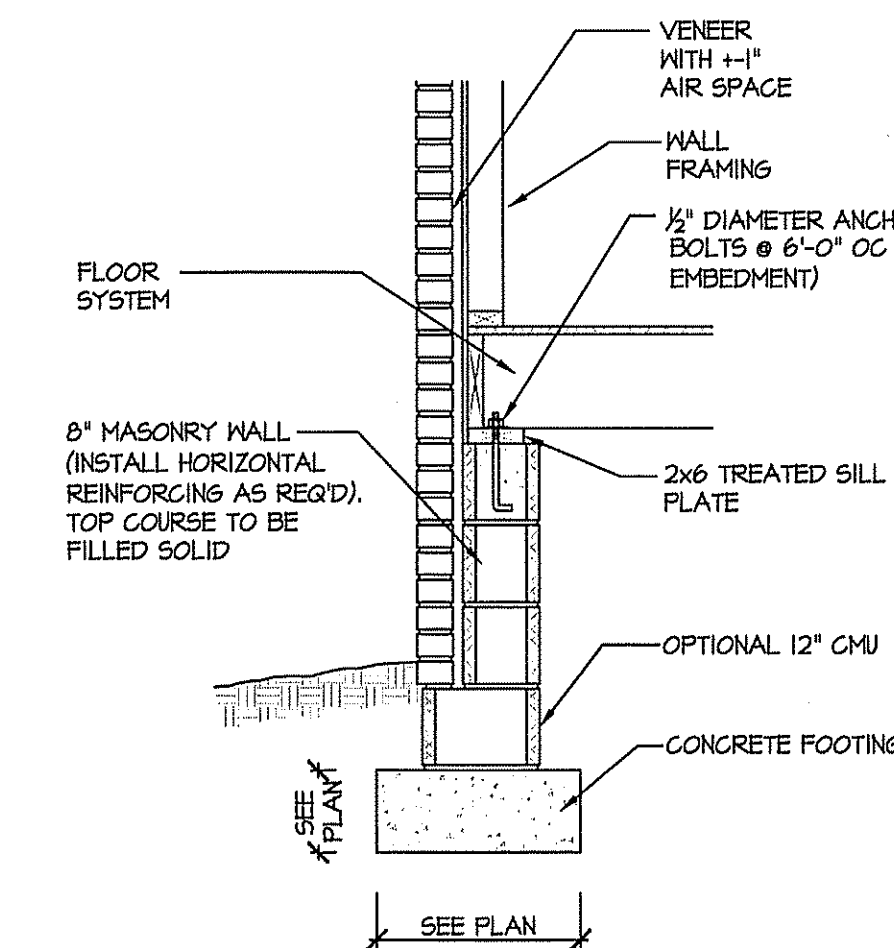

115-120 MPH 112A SD CRAWL SPACE FOOTING (VENEER)

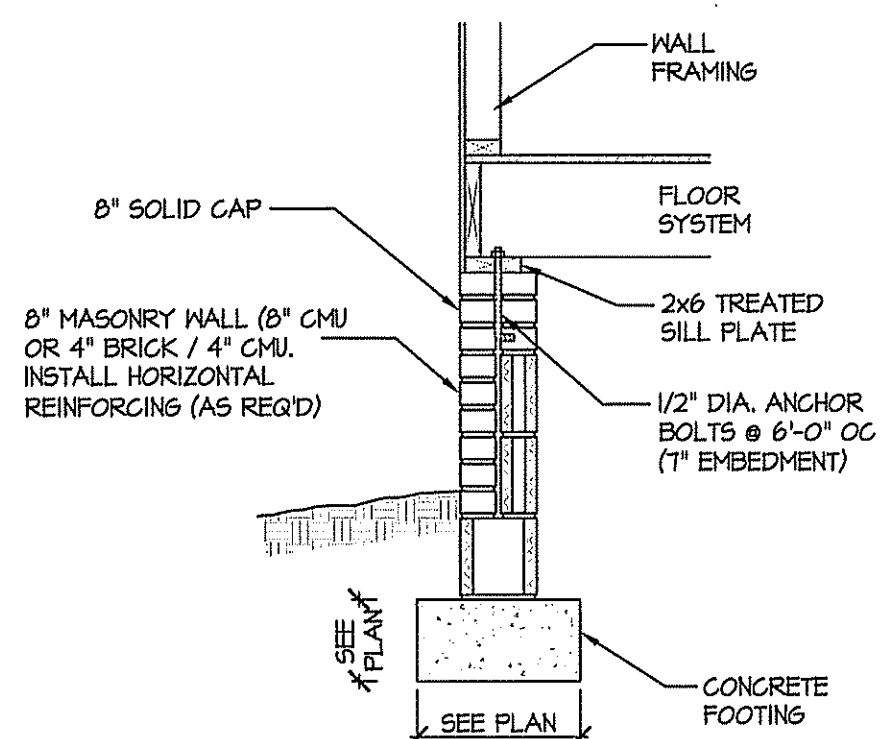

115-120 MPH 110B SD CRAWL SPACE FOOTING (SIDING W/ BRICK SKIRT)

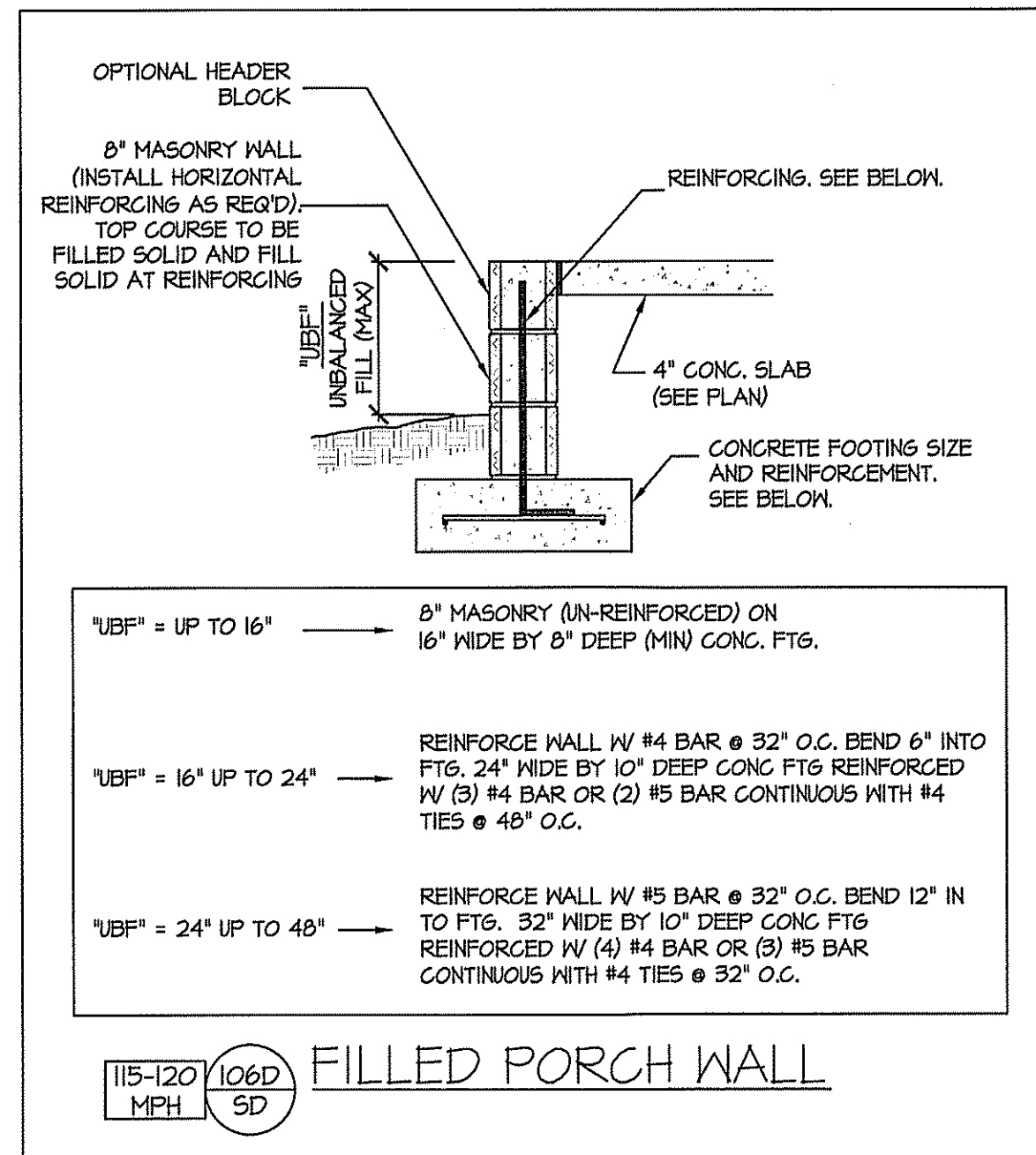

- 'UBF' = UP TO 16" → 8" MASONRY (UN-REINFORCED) ON 16" WIDE BY 8" DEEP (MIN) CONC. FTG.
- 'UBF' = 16" UP TO 24" → REINFORCE WALL W/ #4 BAR @ 32" O.C. BEND 6" INTO FTG. 24" WIDE BY 10" DEEP CONC FTG REINFORCED W/ (2) #4 BAR OR (2) #5 BAR CONTINUOUS WITH #4 TIES @ 48" O.C.
- 'UBF' = 24" UP TO 48" → REINFORCE WALL W/ #5 BAR @ 32" O.C. BEND 12" IN TO FTG. 32" WIDE BY 10" DEEP CONC FTG REINFORCED W/ (4) #4 BAR OR (3) #5 BAR CONTINUOUS WITH #4 TIES @ 32" O.C.

115-120 MPH 106D SD FILLED PORCH WALL

STRUCTURAL NOTES

- NC (2018 NRC); Wind: 115-120 mph
- ENGINEER'S SEAL APPLIES ONLY TO STRUCTURAL COMPONENTS INCLUDING ROOF RAFTERS, HIPs, VALLEYS, RIDGES, FLOORS, WALLS, BEAMS AND HEADERS, COLUMNS, CANTILEVERS, OFFSET LOAD BEARING WALLS, PIER & GIRDER SYSTEM FOOTINGS, AND PILING SYSTEM. ENGINEER'S SEAL DOES NOT CERTIFY DIMENSIONAL ACCURACY OR ARCHITECTURAL LAYOUT INCLUDING ROOF SYSTEM. ALL REQUIREMENTS FOR PROFESSIONAL CERTIFICATION SHALL BE PROVIDED BY THE APPROPRIATE PROFESSIONAL. SOUTHERN ENGINEERS, P.A. CERTIFIES ONLY THE STRUCTURAL COMPONENTS AS SPECIFICALLY STATED.
  - ALL CONSTRUCTION SHALL CONFORM TO THE LATEST REQUIREMENTS OF THE 2018 NC RESIDENTIAL CODE, PLUS ALL LOCAL CODES AND REGULATIONS. THE STRUCTURAL ENGINEER IS NOT RESPONSIBLE FOR, AND WILL NOT HAVE CONTROL OF, CONSTRUCTION MEANS, METHODS, TECHNIQUES, SEQUENCES OR PROCEDURES, OR FOR SAFETY PRECAUTIONS AND PROGRAMS IN CONNECTION WITH THE CONSTRUCTION WORK, NOR WILL THE ENGINEER BE RESPONSIBLE FOR THE CONTRACTOR'S FAILURE TO CARRY OUT THE CONSTRUCTION WORK IN ACCORDANCE WITH THE CONTRACT DOCUMENTS. 'CONSTRUCTION REVIEW' SERVICES ARE NOT PART OF OUR CONTRACT. ALL MEMBERS SHALL BE FRAMED ANCHORED, TIED AND BRACED IN ACCORDANCE WITH GOOD CONSTRUCTION PRACTICE AND THE BUILDING CODE.
  - DESIGN LOADS LISTED AS: LIVE LOAD, DEAD LOAD, DEFLECTION)
    - ROOMS OTHER THAN SLEEPING ROOMS: (40 PSF, 10 PSF, L/360)
    - SLEEPING ROOMS: (30 PSF, 10 PSF, L/360)
    - ATTIC WITH PERMANENT STAIR: (40 PSF, 10 PSF, L/360)
    - ATTIC WITHOUT PERMANENT STAIR: (20 PSF, 10 PSF, L/360)
    - ATTIC WITHOUT STORAGE: (10 PSF, 10 PSF, L/240)
    - STAIRS: (40 PSF, 10 PSF, L/360)
    - EXTERIOR BALCONIES: (60 PSF, 10 PSF, L/360)
    - DECKS: (40 PSF, 10 PSF, L/360)
    - GUARDRAILS AND HANDRAILS: (200 LBS)
    - PASSENGER VEHICLE GARAGES: (50 PSF, 10 PSF, L/360)
    - FIRE ESCAPES: (40 PSF, 10 PSF, L/360)
    - SNOW: (20 PSF)
  - WALLS SHALL BE BRACED BY SHEATHING WALLS ON ALL STORIES WITH WOOD STRUCTURAL PANELS. SEE FRAMING NOTES FOR THICKNESS AND NAILING REQUIREMENTS.
  - SEE APPENDIX H (DCA6) FOR EXTERIOR DECK REQUIREMENTS INCLUDING ATTACHMENTS FOR LATERAL LOADS.
  - CONCRETE SHALL HAVE A MINIMUM 28 DAY STRENGTH OF 3000 PSI AND A MAXIMUM SLUMP OF 5 INCHES UNLESS NOTED OTHERWISE (NO). AIR ENTRAINMENT PER TABLE 402.2. ALL CONCRETE SHALL BE PROPORTIONED, MIXED, HANDLED, SAMPLED, TESTED, AND PLACED IN ACCORDANCE WITH ACI STANDARDS. ALL SAMPLES FOR PUMPING SHALL BE TAKEN FROM THE EXIT END OF THE PUMP. CONTROL JOINTS IN SLABS SHALL BE SPACED ON A GRID OF +30 TIMES THE DEPTH (D). CONTROL JOINTS SHALL BE SAWCUT TO A DEPTH OF 1/3 D. (I.E. 4" CONCRETE SLABS SHALL HAVE 1/4" DEEP CONTROL JOINTS SAWCUT IN SLAB ON A +10'-0" x +10'-0" GRID).
  - ALLOWABLE SOIL BEARING PRESSURE ASSUMED TO BE 2000 PSF. THE CONTRACTOR MUST CONTACT A GEOTECHNICAL ENGINEER AND THE STRUCTURAL ENGINEER IF UNSATISFACTORY SUBSURFACE CONDITIONS ARE ENCOUNTERED. THE SURFACE AREA ADJACENT TO THE FOUNDATION WALL SHALL BE PROVIDED WITH ADEQUATE DRAINAGE, AND SHALL BE GRADED SO AS TO DRAIN SURFACE WATER AWAY FROM FOUNDATION WALLS.
  - ALL FRAMING LUMBER SHALL BE SPF #2 (Fb = 875 PSI) UNLESS NOTED OTHERWISE (NO). ALL TREATED LUMBER SHALL BE SYP # 2. PLATE MATERIAL MAY BE SPF # 3 OR SYP #3 (Fb/perp = 425 PSI - MIN).
    - L.V.L. SHALL BE LAMINATED VENEER LUMBER: Fb=2600 PSI, Fv=285 PSI, E=1.9x10<sup>6</sup> PSI.
    - P.S.L. SHALL BE PARALLEL STRAND LUMBER: Fb=2400 PSI, Fv=240 PSI, E=2.0x10<sup>6</sup> PSI.
    - L.S.L. SHALL BE LAMINATED STRAND LUMBER: Fb=2250 PSI, Fv=400 PSI, E=1.55x10<sup>6</sup> PSI. INSTALL ALL CONNECTIONS PER MANUFACTURERS INSTRUCTIONS.
  - ALL ROOF TRUSS AND I-JOIST LAYOUTS SHALL BE PREPARED IN ACCORDANCE WITH THE SEALED STRUCTURAL DRAWINGS. TRUSSES AND I-JOISTS SHALL BE INSTALLED ACCORDING TO THE MANUFACTURER'S SPECIFICATIONS. ANY CHANGE IN TRUSS OR I-JOIST LAYOUT SHALL BE COORDINATED WITH SOUTHERN ENGINEERS.
  - ALL STRUCTURAL STEEL SHALL BE ASTM A-36. STEEL BEAMS SHALL BE SUPPORTED AT EACH END WITH A MINIMUM BEARING LENGTH OF 3 1/2" INCHES AND FULL FLANGE WIDTH. PROVIDE SOLID BEARING FROM BEAM SUPPORT TO FOUNDATION. BEAMS SHALL BE ATTACHED TO EACH SUPPORT WITH TWO LAG SCREWS (1/2" DIAMETER x 4" LONG). LATERAL SUPPORT IS CONSIDERED ADEQUATE PROVIDING THE JOIST ARE TOE NAILED TO THE SOLE PLATE, AND SOLE PLATE IS NAILED OR BOLTED TO THE BEAM FLANGE @ 48" O.C. ALL STEEL TUBING SHALL BE ASTM A500. LAP ALL REBAR SPLICES 30 BAR DIAMETERS.
  - REBAR SHALL BE DEFORMED STEEL, ASTM615, GRADE 60.
  - FLITCH BEAMS SHALL BE BOLTED TOGETHER USING (2) ROWS OF 1/2" DIAMETER BOLTS (ASTM A325) WITH WASHERS PLACED UNDER THE THREADED END OF BOLT. BOLTS SHALL BE SPACED AT 24" O.C. (MAX), AND STAGGERED AT THE TOP AND BOTTOM OF BEAM (2" EDGE DISTANCE), WITH 2 BOLTS LOCATED AT 6" FROM EACH END.
  - BRICK LINTELS (WHEN REQUIRED) SHALL BE 3 1/2"x3 1/2"x1/4" STEEL ANGLE FOR UP TO 6'-0" SPAN AND 6"x4"x1/16" STEEL ANGLE WITH 6" LEG VERTICAL FOR SPANS UP TO 9'-0". SEE PLANS FOR SPANS OVER 9'-0". SEE ALSO SECTION R103.8.3 LINTELS.

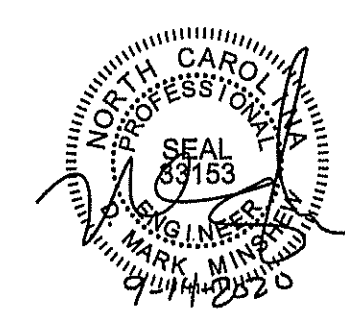

PROJECT #  
20-1702

Engineers seal applies only to structural components on this document.  
Seal does not include construction means, methods, techniques, sequences, procedures or safety precautions.  
Any deviations or discrepancies on plans are to be brought to the immediate attention of Southern Engineers. Failure to do so will void Southern Engineers' liability.  
Seal is valid for projects permitted one year from date of seal.  
Use of these plans constitutes approval of terms & conditions as defined in the customer agreement.

Southern Engineers, P.A.  
3716 Benson Drive, Raleigh, NC 27609  
Phone: (919) 878-1617  
License: C-1287  
www.southernengineers.com

H SQUARED HOME  
DESIGN, INC.

Kim Breden &  
Fergie Roper Residence

SD

**THIS LAYOUT IS INTENDED FOR THE PURPOSE OF TRUSS LOCATION AND PLACEMENT ONLY. REFER TO THE BUILDING PLANS FOR ACTUAL BUILDING CONSTRUCTION.**

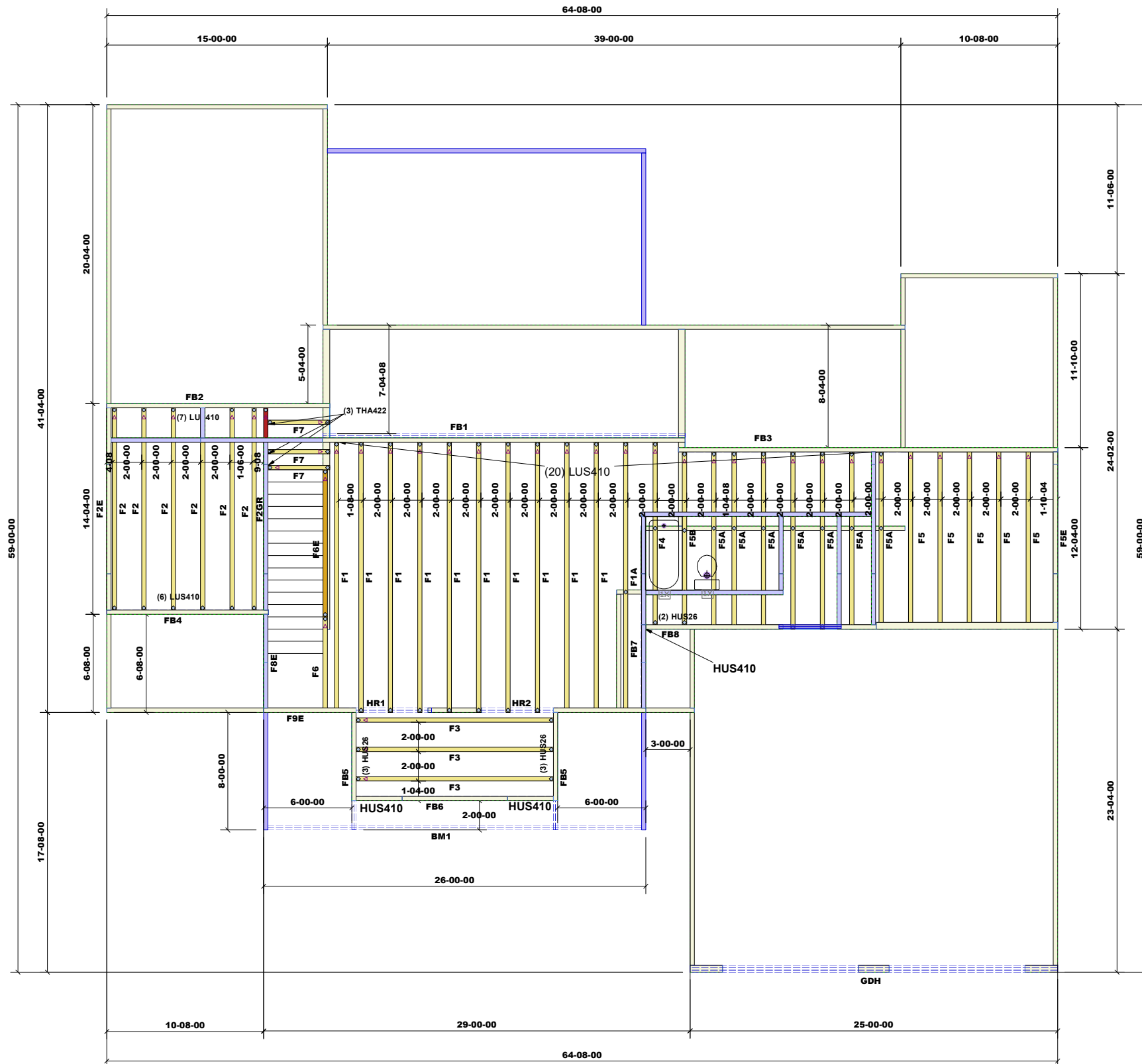

PlotID	Length	Product	Plies	Net Qty	Fab Type
BM1	26-00-00	1-3/4" x 9-1/4" VERSA-LAM@ 2.0 3100 SP	2	2	MFD
GDH	26-00-00	1-3/4" x 11-7/8" VERSA-LAM@ 2.0 3100 SP	3	3	MFD
HR2	8-00-00	1-3/4" x 11-7/8" VERSA-LAM@ 2.0 3100 SP	2	2	MFD
HR1	6-00-00	1-3/4" x 11-7/8" VERSA-LAM@ 2.0 3100 SP	2	2	MFD
FB2	16-00-00	1-3/4" x 14" VERSA-LAM@ 2.0 3100 SP	2	2	MFD
FB3	16-00-00	1-3/4" x 14" VERSA-LAM@ 2.0 3100 SP	2	2	MFD
FB6	14-00-00	1-3/4" x 14" VERSA-LAM@ 2.0 3100 SP	2	2	MFD
FB4	12-00-00	1-3/4" x 14" VERSA-LAM@ 2.0 3100 SP	2	2	MFD
FB5	10-00-00	1-3/4" x 14" VERSA-LAM@ 2.0 3100 SP	2	4	MFD
FB7	10-00-00	1-3/4" x 14" VERSA-LAM@ 2.0 3100 SP	2	2	MFD
FB8	4-00-00	1-3/4" x 14" VERSA-LAM@ 2.0 3100 SP	2	2	MFD
FB1	26-00-00	1-3/4" x 24" VERSA-LAM@ 2.0 3100 SP	4	4	MFD

Crawl Level Floor Area	1st Level Floor Area	2nd Level Floor Area
0	1079.6	0



DEDICATED TO QUALITY AND EXCELLENCE  
200 EMMETT ROAD  
DUNN, NORTH CAROLINA 28334  
PHONE: 910-892-8400

**PROJECT:** WELLONS - BREEDEN  
**CUSTOMER:** Wellon Homes  
**MODEL:** Breedren 2nd Floor  
**QUOTE #:** 2000471  
**PRINT DATE:** 10/16/2017  
**DRAWN BY:** Rodney Evans  
**SCALE:** N.T.S

**TOP LIVE LOAD:** 40.0 lb/ft<sup>2</sup>  
**TOP DEAD LOAD:** 10.0 lb/ft<sup>2</sup>  
**BOTTOM LIVE LOAD:**  
**BOTTOM DEAD LOAD:** 5.0 lb/ft<sup>2</sup>

**GENERAL NOTES:**  
- DO NOT CUT OR MODIFY TRUSSES  
- TRUSSES ARE SPACED 24" ON CENTER UNLESS OTHERWISE NOTED  
- REFER TO THE INDIVIDUAL TRUSS DESIGN DRAWINGS FOR THE LOCATION OF LATERAL BRACING AND MULTI-PLY CONNECTION REQUIREMENTS.  
- PER ANSI TPI 1-2002 THE TRUSS ENGINEER IS RESPONSIBLE FOR TRUSS TO TRUSS CONNECTIONS AND TRUSS PLY TO PLY CONNECTIONS. THIS TRUSS PLAN RECOMMENDS TRUSS TO BEARING CONNECTIONS AND TRUSS TO BEAM CONNECTIONS WHICH SHALL BE REVIEWED BY THE BUILDING DESIGNER. IT IS THE RESPONSIBILITY OF THE BUILDING DESIGNER TO RESOLVE ALL ROOF FORCES ADEQUATELY TO THE FOUNDATION.



THIS LAYOUT IS INTENDED FOR THE PURPOSE OF TRUSS LOCATION AND PLACEMENT ONLY. REFER TO THE BUILDING PLANS FOR ACTUAL BUILDING CONSTRUCTION.

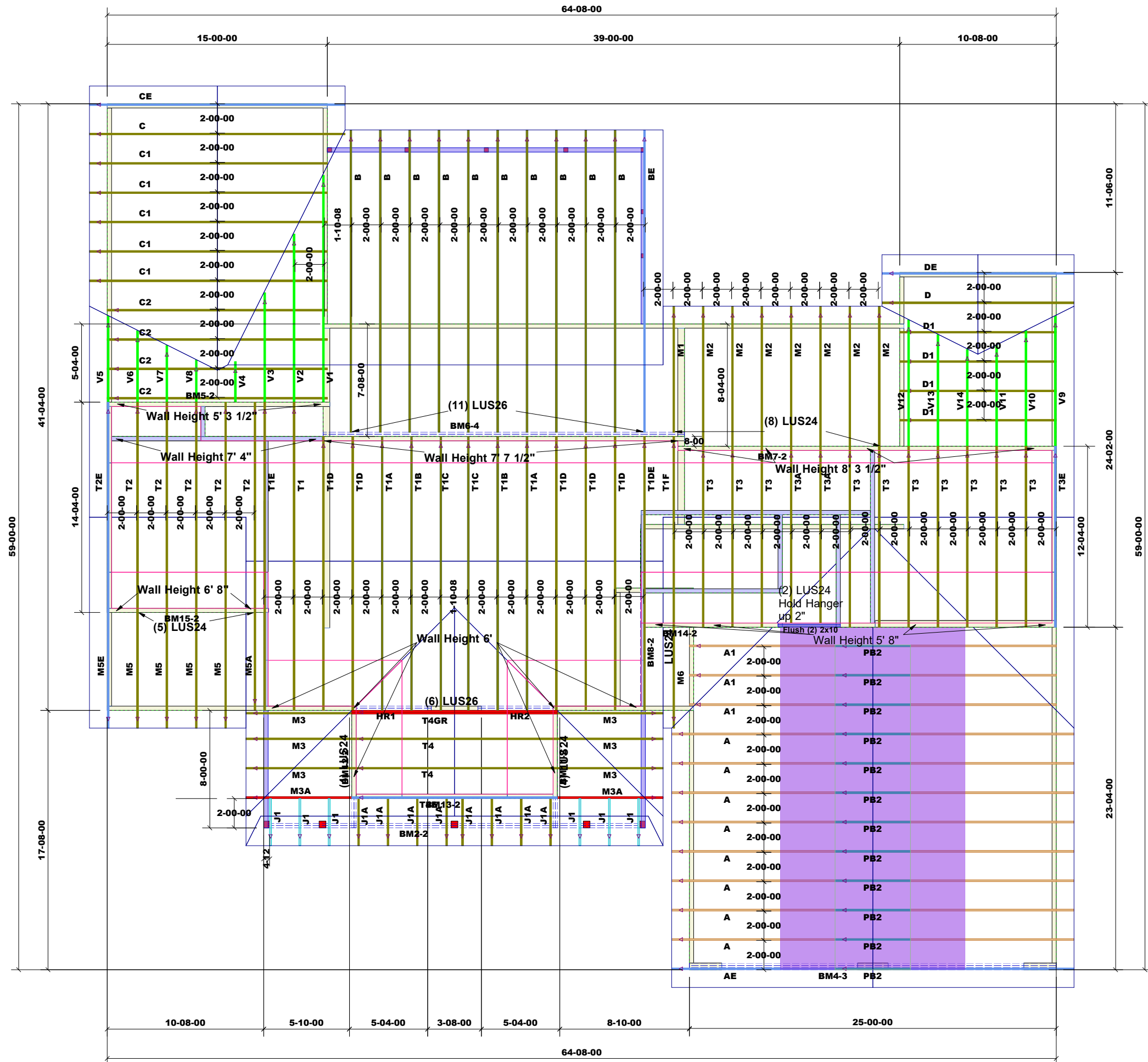

1st Level Roof Area	2nd Level Roof Area
4267.93	0



DEDICATED TO QUALITY AND EXCELLENCE  
 200 EMMETT ROAD  
 DUNN, NORTH CAROLINA 28334  
 PHONE: 910-892-8400

PROJECT:	WELLONS - BREEDEN		
CUSTOMER:	Wellon Homes		
MODEL:	Breeden		
QUOTE #:	2000470	PRINT DATE:	9/21/2020
DRAWN BY:	Rodney Evans	SCALE:	N.T.S

TOP LIVE LOAD:	20.0 lb/ft <sup>2</sup>
TOP DEAD LOAD:	10.0 lb/ft <sup>2</sup>
BOTTOM DEAD LOAD:	10.0 lb/ft <sup>2</sup>
WIND SPEED:	130 mph

GENERAL NOTES:  
 - DO NOT CUT OR MODIFY TRUSSES  
 - TRUSSES ARE SPACED 24" ON CENTER UNLESS OTHERWISE NOTED  
 - REFER TO THE INDIVIDUAL TRUSS DESIGN DRAWINGS FOR THE LOCATION OF LATERAL BRACING AND MULTI-PLY CONNECTION REQUIREMENTS.  
 - PER ANSI TPI 1-2002 THE TRUSS ENGINEER IS RESPONSIBLE FOR TRUSS TO TRUSS CONNECTIONS AND TRUSS PLY TO PLY CONNECTIONS. THIS TRUSS PLAN RECOMMENDS TRUSS TO BEARING CONNECTIONS AND TRUSS TO BEAM CONNECTIONS WHICH SHALL BE REVIEWED BY THE BUILDING DESIGNER. IT IS THE RESPONSIBILITY OF THE BUILDING DESIGNER TO RESOLVE ALL ROOF FORCES ADEQUATELY TO THE FOUNDATION.