

**NOTICE TO CONTRACTOR**  
 All construction must comply with current NC Building Codes and is subject to field inspection and verification.

**APPROVED**  
 Limited building only review  
 Permit holder responsible for full compliance with the code

09/09/2020

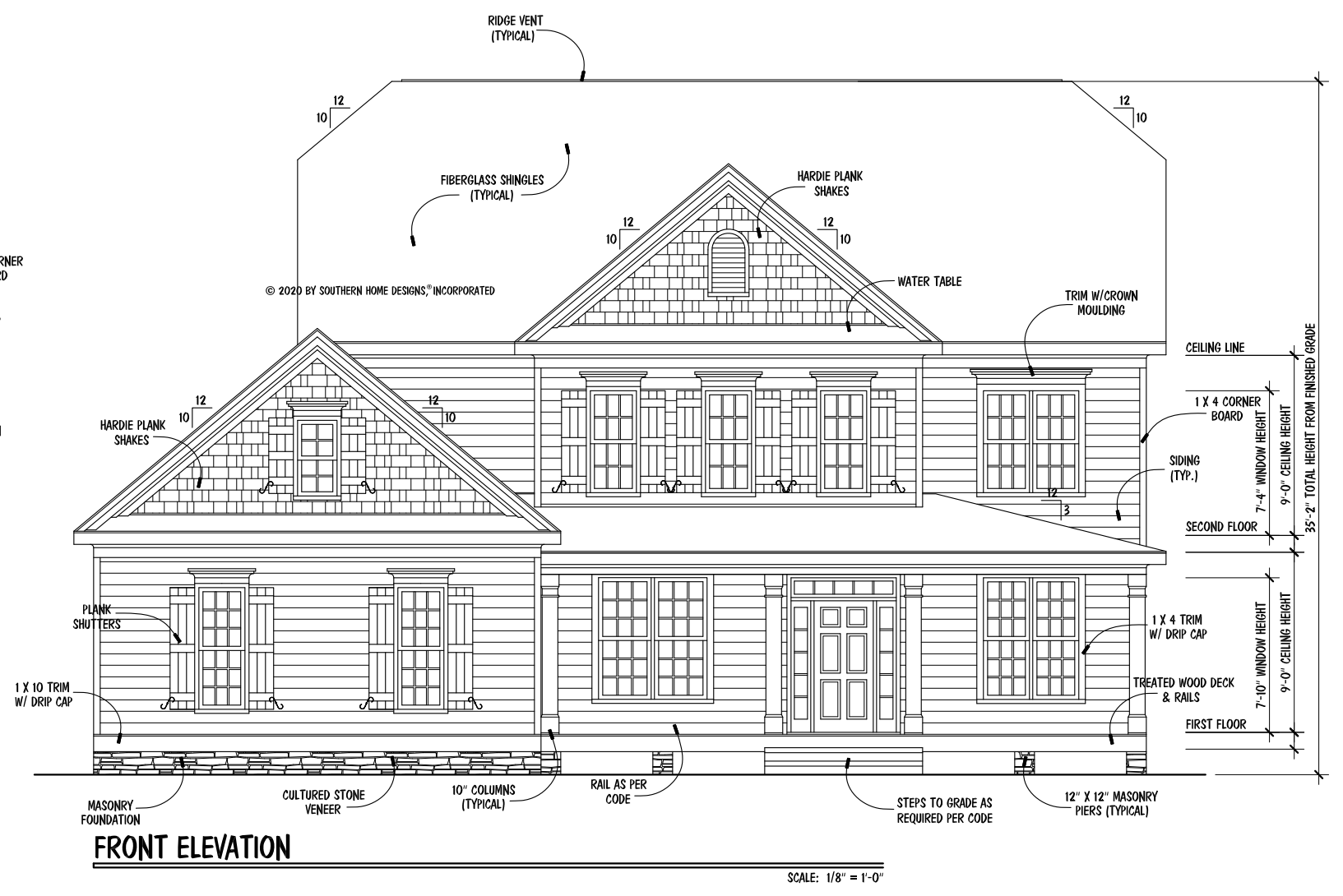

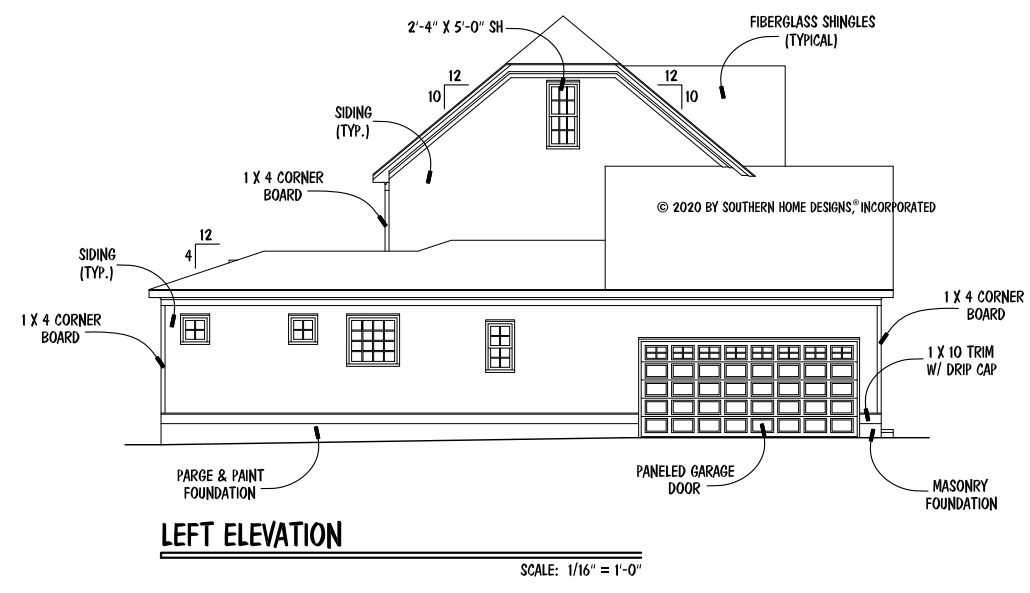
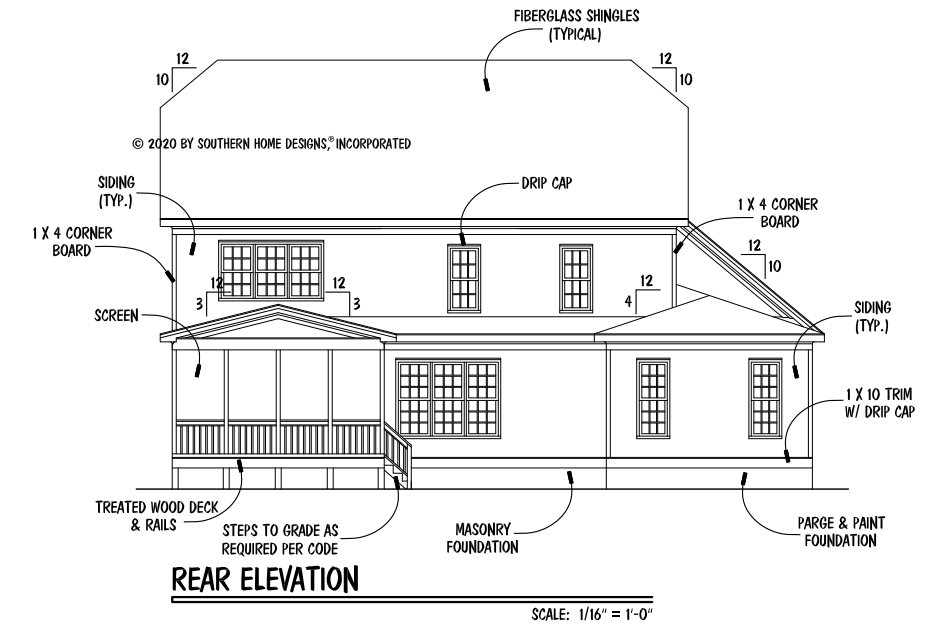
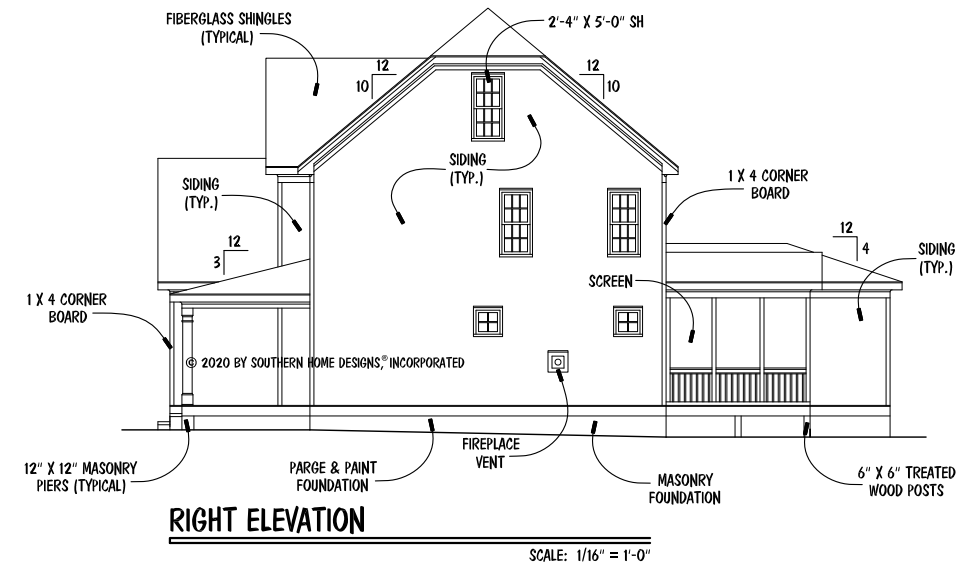

© 2020 BY SOUTHERN HOME DESIGNS, INCORPORATED  
 THESE PLANS ARE PROTECTED UNDER FEDERAL COPYRIGHT LAWS.  
 THE ORIGINAL PURCHASER OF THESE PLANS IS LICENSED TO USE  
 THE PLANS FOR THE CONSTRUCTION OF ONE AND ONLY ONE  
 SINGLE FAMILY HOME. REPRODUCTION, MODIFICATION, OR REUSE  
 OF THESE PLANS WITHOUT THE WRITTEN CONSENT OF SOUTHERN  
 HOME DESIGNS, INCORPORATED, IS EXPRESSLY PROHIBITED.

Houseplan Works.com  
 ALL DIMENSIONS AND SITE DIMENSIONS ARE TO BE VERIFIED  
 BEFORE CONSTRUCTION BEGINS. ONCE CONSTRUCTION HAS  
 BEGUN SOUTHERN HOME DESIGNS, INCORPORATED, IS RELEASED  
 FROM ANY FURTHER RESPONSIBILITIES.

**Southern Home Designs**  
 INCORPORATED  
 301 South Salem Street, Suite 101, Apex, NC 27502  
 919.380.7400 Office 919.380.7464 Fax  
 Web: shdplans.com Email: shd@nc-rr.com

THE  
**VICTORIA 2020**  
 LOT 3 CHRISTIAN LIGHT

**TRIPLE A  
 HOMES, INC.**

ENGR. #:  
 DATE: 08-01-20  
 SHEET: A-1  
 PLAN #: 20-080120

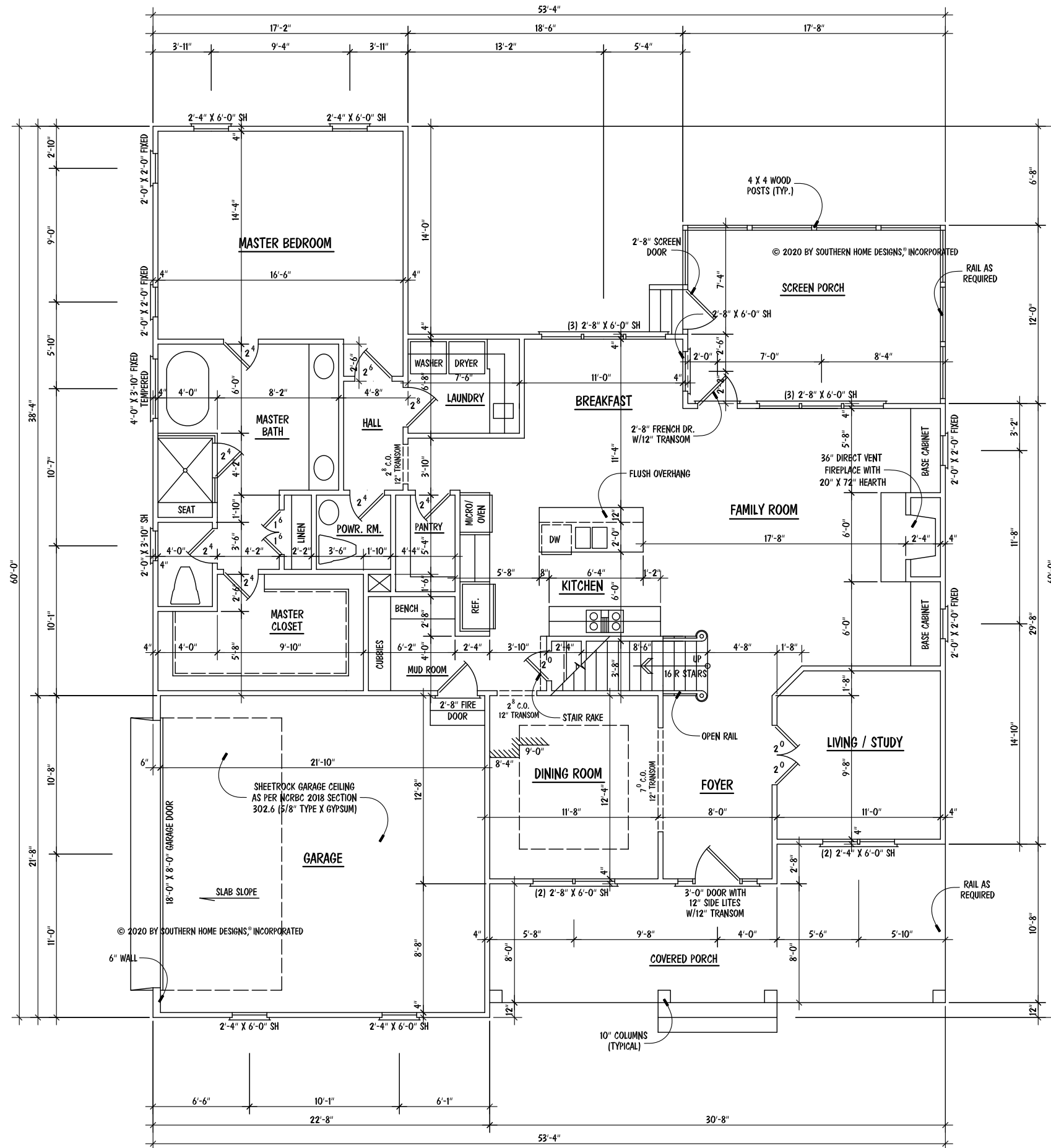

- NOTES:**
- 9'-0" CEILING HGT. (TYP.) U.N.O.
  - SET WINDOWS @ 7'-10" A.F.F. (TYP.) U.N.O
  - SET WINDOW IN MASTER TOILET @ 7'-4" A.F.F.
  - STAIRS: UP 16 R (TYP.), 1ST FLOOR TO 2ND FLOOR

- NOTES:**
- MEAN ROOF HEIGHT FOR THIS STRUCTURE IS 23'-3"

**ATTIC VENTILATION:**

2793 SQUARE FEET = 9.31 REQUIRED  
300

THE NET FREE AREA OF VENTILATION REQUIRED IS TO BE

9.31 SQUARE FEET.

**CRAWL SPACE VENTILATION**

1820 SQ. FT. OF CRAWL AREA / 150 = 12.13 SQ. FT. OF FREE VENT AREA REQUIRED

SEE SECTION R408.1 OF 2018 NCRBC (2015 IRC)

FREE VENT AREA REQUIRED MAY BE REDUCED TO 1/1500 IF APPROVED VAPOR BARRIER IS INSTALLED OVER 100% OF CRAWL FLOOR AREA AND VENTS ARE INSTALLED TO PERMIT CROSS-VENTILATION OF CRAWL SPACE. SEE SECTION R408.1.1.

**SQUARE FOOTAGE**

FIRST FLOOR	1820
SECOND FLOOR	1056
<b>TOTAL</b>	<b>2876</b>

**MISCELLANEOUS**

GARAGE	487
FRONT PORCH	276
SCREEN PORCH	210
UNFIN. STORAGE	386

**FIRST FLOOR PLAN**

SCALE: 1/8" = 1'-0"

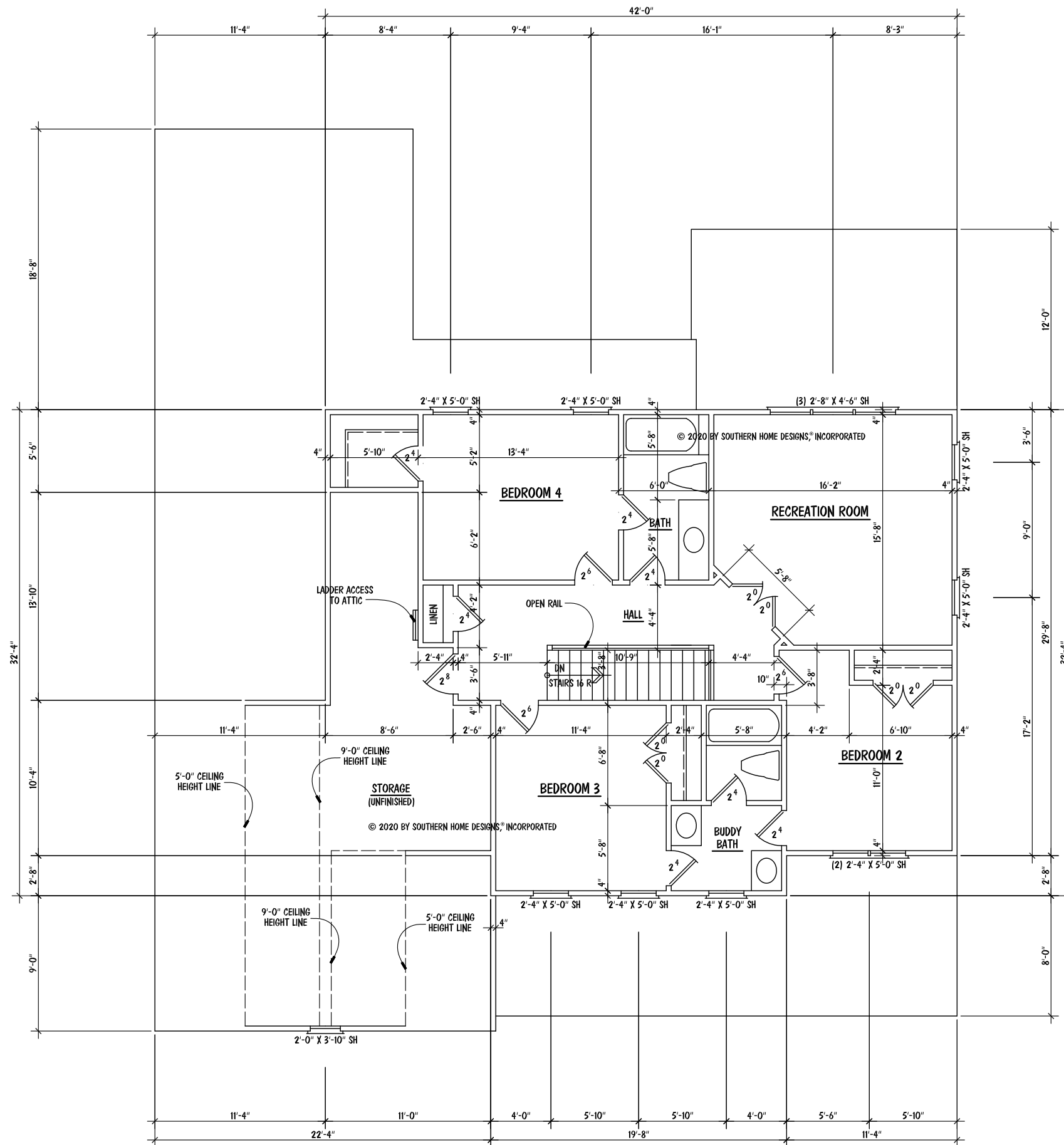

**NOTES:**

- 9'-0" CEILING HGT. (TYP.) U.N.O.
- SET WINDOWS @ 7'-4" A.F.F. (TYP.) U.N.O
- SET WINDOWS IN RECREATION ROOM @ 7'-8" A.F.F.
- SET FRONT WINDOW IN STORAGE @ 5'-10" A.F.F.
- STAIRS: DN 16 R (TYP.), 2ND FLOOR TO 1ST FLOOR

**SECOND FLOOR PLAN**

SCALE: 1/8" = 1'-0"

© 2020 BY SOUTHERN HOME DESIGNS, INCORPORATED

© 2020 BY SOUTHERN HOME DESIGNS, INCORPORATED. THESE PLANS ARE PROTECTED UNDER FEDERAL COPYRIGHT LAWS. THE ORIGINAL PURCHASER OF THESE PLANS IS LICENSED TO USE THE PLANS FOR THE CONSTRUCTION OF ONE AND ONLY ONE SINGLE FAMILY HOME. REPRODUCTION, MODIFICATION, OR REUSE OF THESE PLANS WITHOUT THE WRITTEN CONSENT OF SOUTHERN HOME DESIGNS, INCORPORATED, IS EXPRESSLY PROHIBITED.

Houseplan Works.com  
ALL DIMENSIONS AND SITE DIMENSIONS ARE TO BE VERIFIED BEFORE CONSTRUCTION BEGINS. ONCE CONSTRUCTION HAS BEGUN SOUTHERN HOME DESIGNS, INCORPORATED, IS RELEASED FROM ANY FURTHER RESPONSIBILITIES.

**Southern Home Designs**  
INCORPORATED  
301 South Salem Street, Suite 101, Apex, NC 27502  
919.380.7400 Office 919.380.7464 Fax  
Web: shdplans.com Email: shd@ncrr.com

THE VICTORIA 2020  
LOT 3 CHRISTIAN LIGHT

TRIPLE A  
HOMES, INC.

ENGR. #:  
DATE: 08-01-20  
SHEET: A-3  
PLAN #: 20-080120

The structural design of this plan is the property of Engineering Tech Associates, P.A. These plans are for the one time use at the location and for the client listed. Engineering Tech Associates, P.A. assumes no liability for these plans if they are reproduced, in whole or in part, for construction at any other location without written permission from Engineering Tech Associates, P.A.

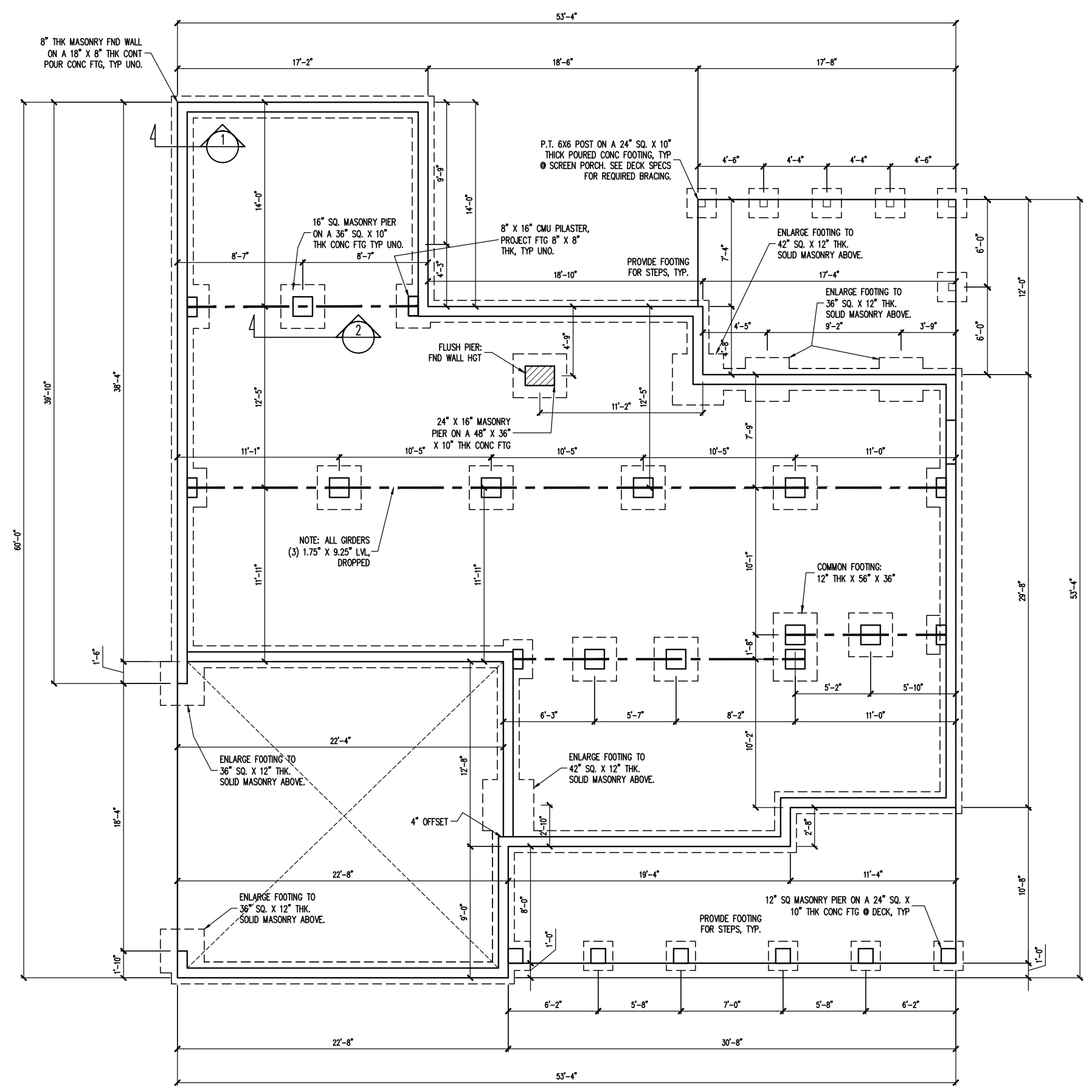
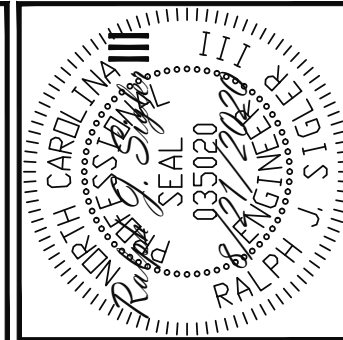

NOTES:  
 -HEIGHT AND BACKFILL LIMITATIONS FOR FOUNDATION WALLS ARE TO BE GOVERNED BY THE NCSBC, LATEST EDITION. REINFORCEMENT AND GROUTING SHALL BE DETERMINED BY FINAL SITE CONDITIONS.  
 -BUILDER TO FIELD LOCATE CRAWLSPACE ACCESS OPENING WITH MINIMUM DIMENSIONS OF 18X24. DO NOT LOCATE ACCESS OPENING BELOW POINT LOADS FROM ABOVE WITHOUT ENGINEER APPROVAL.

**Engineering Tech**  
 ASSOCIATES, P.A. (919) 844-1661  
 STRUCTURAL ENGINEERS  
 License No. C-3870  
 183 Wind Chime Court, Suite 100  
 Raleigh, North Carolina 27615  
 Fax (919) 844-1665

CLIENT:	TRIPLE A HOMES
SCOPE:	STRUCTURAL ADDENDUM
LOT #:	3 CHRISTIAN LIGHT
ENG:	RJS/CMC
REV:	
DATE:	8/21/2020

PLAN NO.	VICTORIA 2020
PROJECT NO.	20-28-028
SHEET NO.	S1
	1 of 10

FOUNDATION PLAN  
 1/8" = 1'-0"

The structural design of this plan is the property of Engineering Tech Associates, P.A. These plans are for the one time use at the location and for the client listed. Engineering Tech Associates, P.A. assumes no liability for these plans if they are reproduced, in whole or in part, for construction at any other location without written permission from Engineering Tech Associates, P.A.

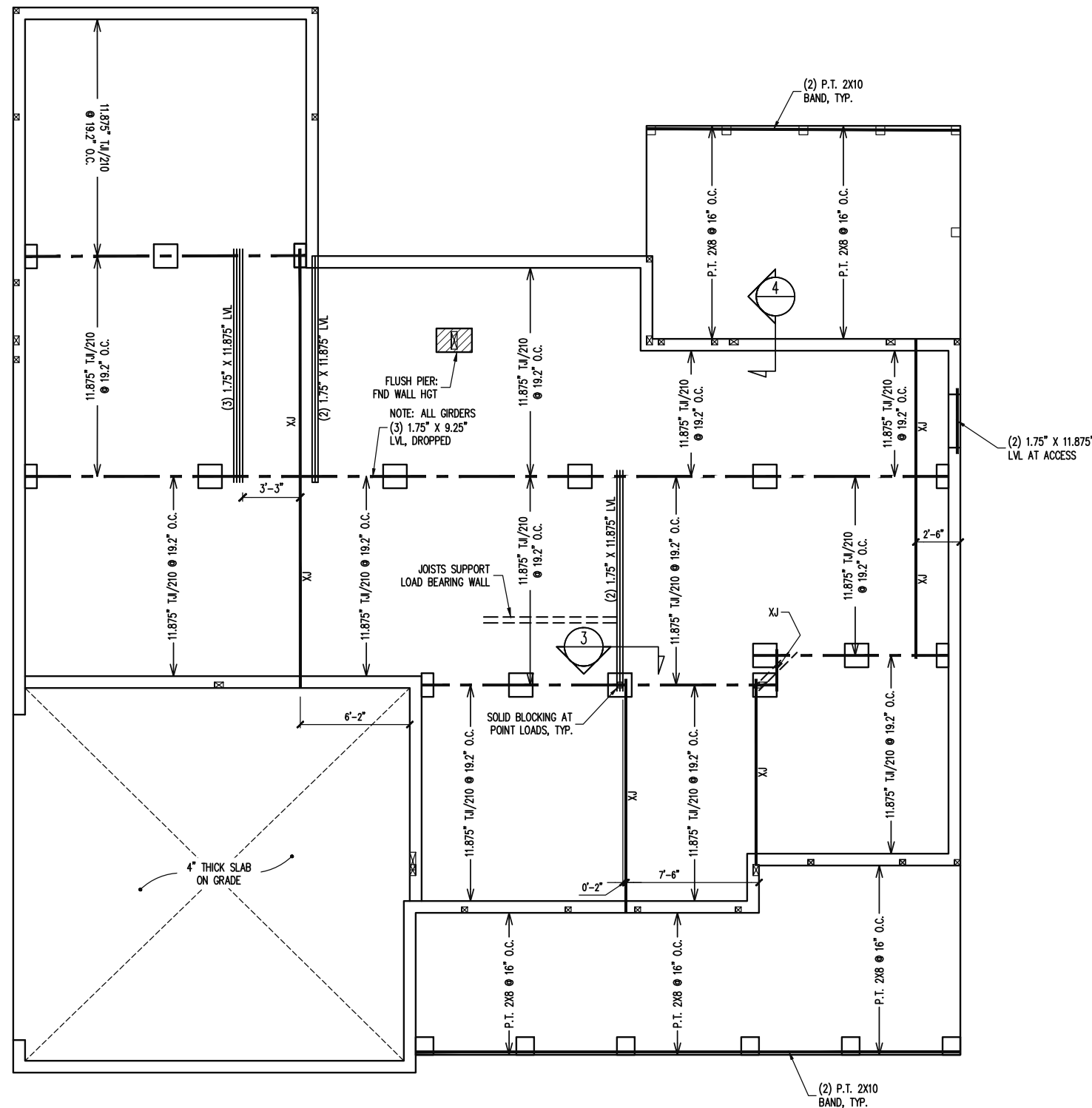
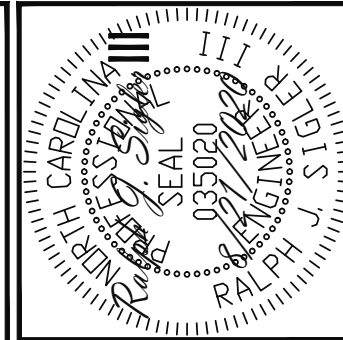

**Engineering Tech ASSOCIATES, P.A.**  
**STRUCTURAL ENGINEERS**  
 License No. C-3870  
 183 Wind Chime Court, Suite 100  
 Raleigh, North Carolina 27615  
 ASSOCIATES, P.A. (919) 844-1661 Fax (919) 844-1665

CLIENT:	TRIPLE A HOMES
SCOPE:	STRUCTURAL ADDENDUM
LOT #:	3 CHRISTIAN LIGHT
ENG:	RJS/CMC
REV:	
DATE:	8/21/2020

PLAN NO.  
VICTORIA 2020

PROJECT NO.  
20-28-028

SHEET NO.  
S2

2 of 10

CRAWL SPACE FRAMING PLAN  
 1/8" = 1'-0"

The structural design of this plan is the property of Engineering Tech Associates, P.A. These plans are for the one time use at the location and for the client listed. Engineering Tech Associates, P.A. assumes no liability for these plans if they are reproduced, in whole or in part, for construction at any other location without written permission from Engineering Tech Associates, P.A.

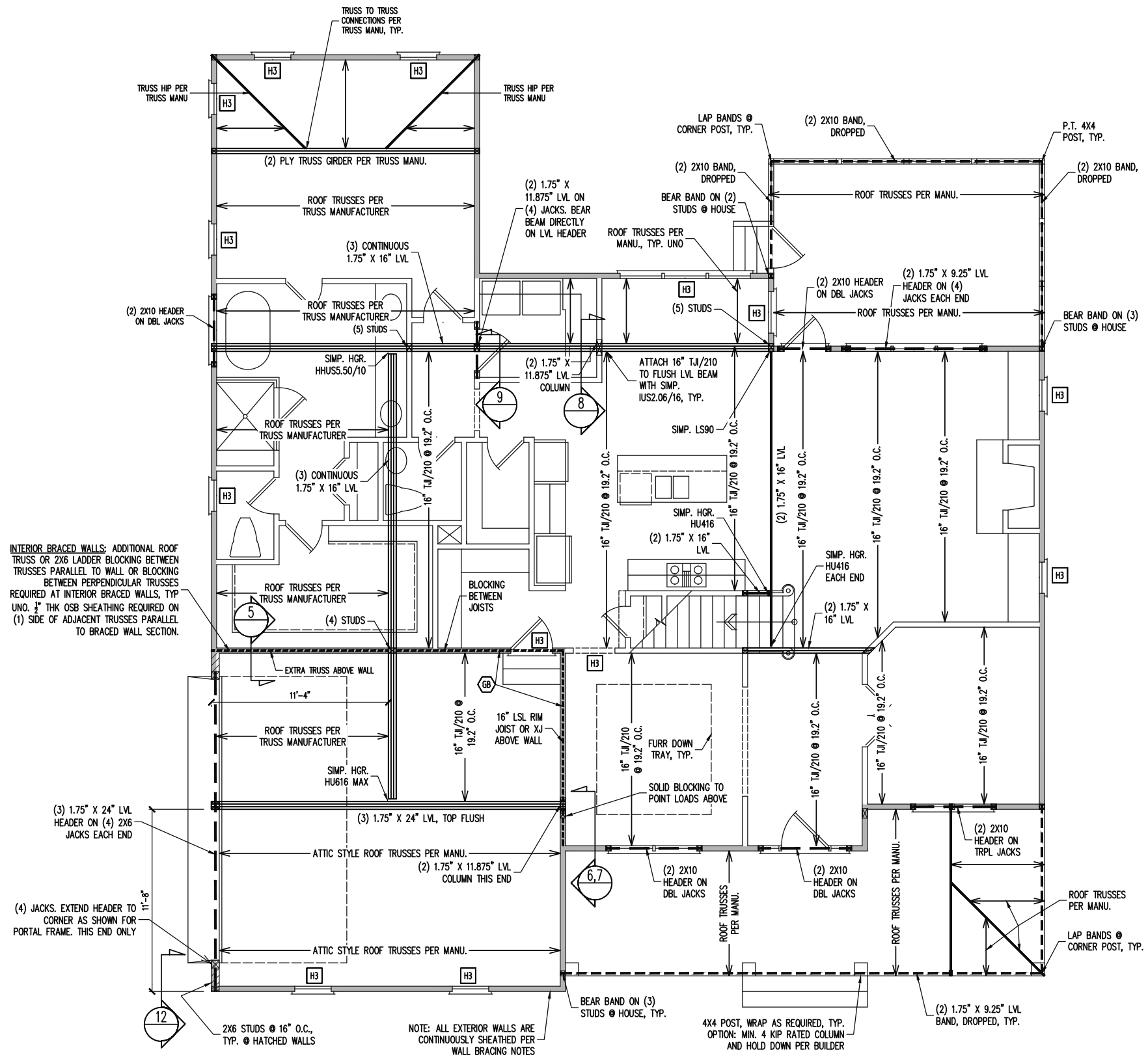
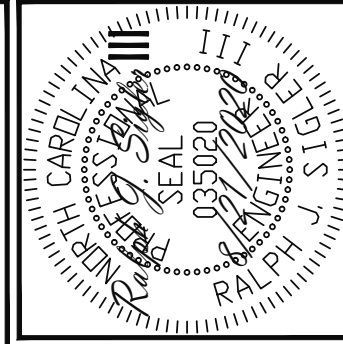

INTERIOR BRACED WALLS: ADDITIONAL ROOF TRUSS OR 2X6 LADDER BLOCKING BETWEEN TRUSSES PARALLEL TO WALL OR BLOCKING BETWEEN PERPENDICULAR TRUSSES REQUIRED AT INTERIOR BRACED WALLS, TYP. UNO. 3/8" THK OSB SHEATHING REQUIRED ON (1) SIDE OF ADJACENT TRUSSES PARALLEL TO BRACED WALL SECTION.

NOTE: ALL EXTERIOR WALLS ARE CONTINUOUSLY SHEATHED PER WALL BRACING NOTES

HEADER SCHEDULE	
H1	SINGLE 2X4 TURNED FLAT (A)
H2	(2) 2X4'S ON SINGLE JACKS (B)
H3	(2) 2X10'S ON SINGLE JACKS (C)
H4	(2) 1.75" X 9.25" LVL'S ON DBL JACKS
H5	(3) 2X10'S ON SINGLE JACKS

(A) TYPICAL FOR INTERIOR NON LOAD BEARING WALLS ONLY, ROUGH OPENING 38" MAX.  
 (B) TYPICAL FOR INTERIOR NON LOAD BEARING WALLS ONLY, ROUGH OPNG 38" TO 74" MAX.  
 (C) TYPICAL FOR ALL CONDITIONS NOT LISTED IN (A) OR (B) UNO.

NOTES:  
 -HEADERS IN NON LOAD BEARING INTERIOR WALLS ARE NOT LABELED.

**CONSTRUCTION SPECIFICATIONS**  
 INSTANT REFERENCES

REFER TO THE CONSTRUCTION SPECIFICATIONS SECTIONS FOR THE FOLLOWING INFORMATION:

PART 1.01: CURRENT GOVERNING CODE

PART 14: STUD SUPPORT FOR BEAMS

PART 17: KING STUDS FOR EXTERIOR WALLS

SEE DETAIL / CONSTRUCTION SPECIFICATIONS SHEETS FOR I-JOISTS ALLOWABLE SUBSTITUTIONS

**WALL BRACING**

SHADED WALLS:

ALL EXTERIOR STUD WALLS, EXTERIOR SIDE, ARE TO BE CONTINUOUSLY SHEATHED WITH 7/16 APA RATED OSB NAILED TO STUDS WITH 8d NAILS @ 6" O.C. AT PANEL EDGES, 12" O.C. IN PANEL FIELD.

WSP - ONE SIDE OF INTERIOR WALL OR INSIDE OF EXTERIOR WALL WITH 3/8" MIN. THICKNESS WOOD STRUCTURAL PANELING. ATTACH WSP TO STUD WALL WITH 8d NAILS @ 4" O.C. AT PANEL EDGES, 8" O.C. IN PANEL FIELD.

GB - INTERIOR BRACED WALL. 1/2" GB SECURED PER TABLE R602.10.2 OF THE 2018 NCRBC. (FASTENERS @ 7" O.C.) BOTH SIDES OF WALL OR (FASTENERS @ 4" O.C.) ONE SIDE OF WALL AT STAIRS

NOTES:  
 PROVIDED CONTINUOUS SHEATHING = 225' MIN.

REFERENCE PART 16.02 OF CONSTRUCTION SPECIFICATIONS FOR GENERAL WIND BRACING INFORMATION.

**STRUCTURAL ENGINEERS**  
 License No. C-3870  
 183 Wind Chime Court, Suite 100  
 Raleigh, North Carolina 27615  
 ASSOCIATES, P.A. (919) 844-1661 Fax (919) 844-1665

CLIENT:	TRIPLE A HOMES
SCOPE:	STRUCTURAL ADDENDUM
LOT #:	3 CHRISTIAN LIGHT
ENG:	RJS/CMC
REV:	
DATE:	8/21/2020

PLAN NO.  
**VICTORIA 2020**

PROJECT NO.  
**20-28-028**

SHEET NO.  
**S3**

The structural design of this plan is the property of Engineering Tech Associates, P.A. These plans are for the one time use at the location and for the client listed. Engineering Tech Associates, P.A. assumes no liability for these plans if they are reproduced, in whole or in part, for construction at any other location without written permission from Engineering Tech Associates, P.A.

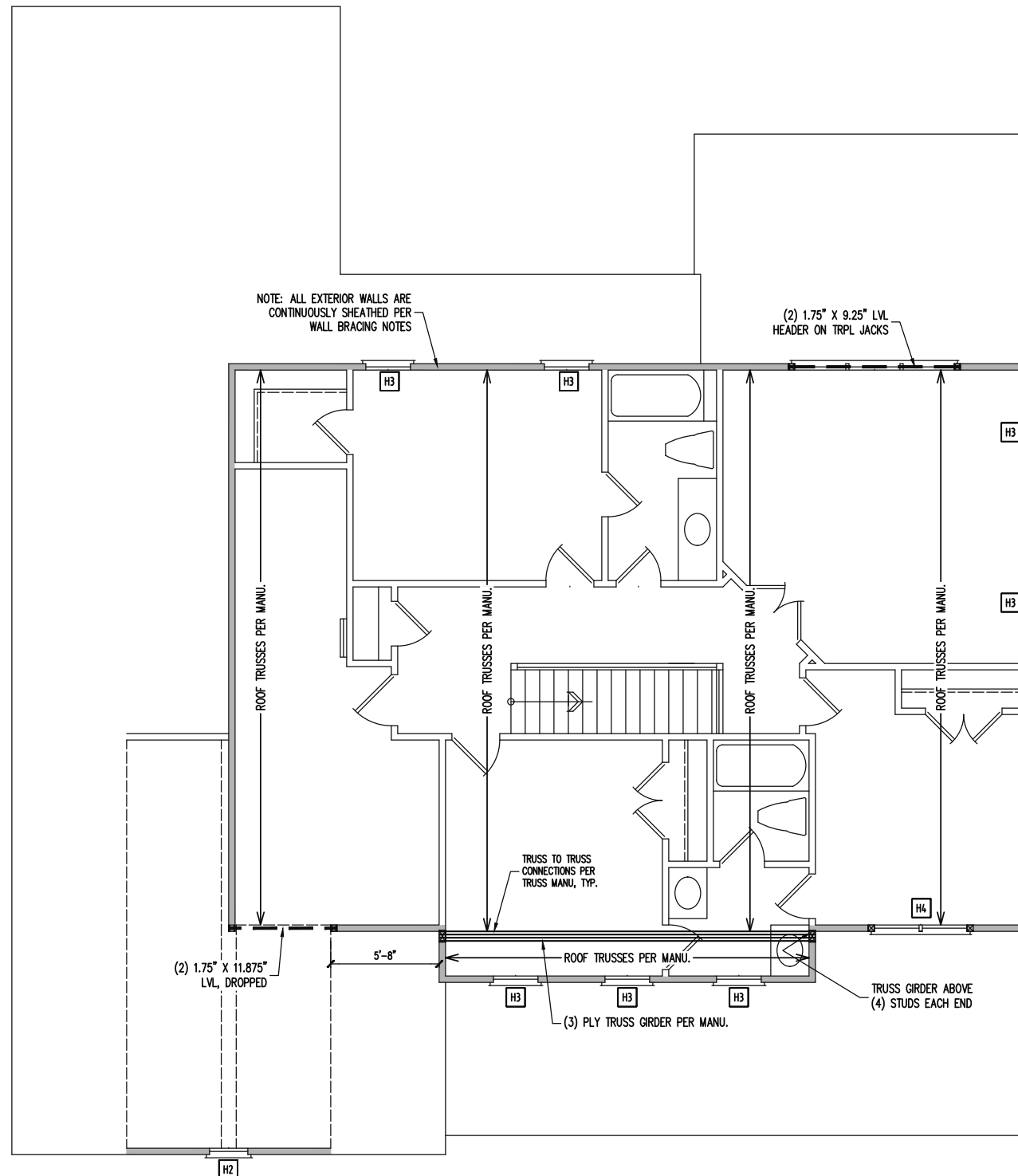
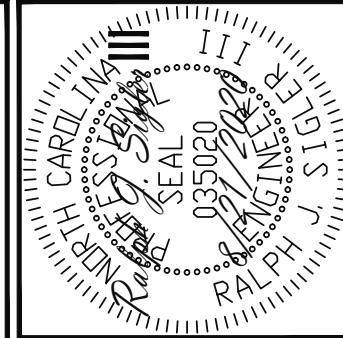

**CONSTRUCTION SPECIFICATIONS**  
**INSTANT REFERENCES**  
 REFER TO THE CONSTRUCTION SPECIFICATIONS SECTIONS FOR THE FOLLOWING INFORMATION:  
 PART 1.01: CURRENT GOVERNING CODE  
 PART 14: STUD SUPPORT FOR BEAMS  
 PART 17: KING STUDS FOR EXTERIOR WALLS

**WALL BRACING**  
 SHADED WALLS:  
 ALL EXTERIOR STUD WALLS, EXTERIOR SIDE, ARE TO BE CONTINUOUSLY SHEATHED WITH 7/16 APA RATED OSB NAILED TO STUDS WITH 8d NAILS @ 6" O.C. AT PANEL EDGES, 12" O.C. IN PANEL FIELD.  
 NOTES:  
 PROVIDED CONTINUOUS SHEATHING = 152' MIN.  
 REFERENCE PART 16.02 OF CONSTRUCTION SPECIFICATIONS FOR GENERAL WIND BRACING INFORMATION.

**HEADER SCHEDULE**

H1 SINGLE 2X4 TURNED FLAT (A)  
 H2 (2) 2X4'S ON SINGLE JACKS (B)  
 H3 (2) 2X10'S ON SINGLE JACKS (C)  
 H4 (2) 1.75" X 9.25" LVL'S ON DBL JACKS  
 H5 (3) 2X10'S ON SINGLE JACKS

(A) TYPICAL FOR INTERIOR NON LOAD BEARING WALLS ONLY, ROUGH OPENING 38" MAX.  
 (B) TYPICAL FOR INTERIOR NON LOAD BEARING WALLS ONLY, ROUGH OPNG 38" TO 74" MAX.  
 (C) TYPICAL FOR ALL CONDITIONS NOT LISTED IN (A) OR (B) UNO.

NOTES:  
 -HEADERS IN NON LOAD BEARING INTERIOR WALLS ARE NOT LABELED.

**Engineering Tech ASSOCIATES, P.A.**  
 STRUCTURAL ENGINEERS  
 License No. C-3870  
 183 Wind Chime Court, Suite 100  
 Raleigh, North Carolina 27615  
 P.A.(919) 844-1661 Fax (919) 844-1665

CLIENT:	TRIPLE A HOMES
SCOPE	STRUCTURAL ADDENDUM
LOT #:	3 CHRISTIAN LIGHT
ENG:	RJS/CMC
REV:	
DATE:	8/21/2020

PLAN NO.  
**VICTORIA 2020**

PROJECT NO.  
**20-28-028**

SHEET NO.  
**S4**

4 of 10

**2ND FLOOR FRAMING PLAN**  
 WALLS AND CEILING  
 1/8" = 1'-0"

The structural design of this plan is the property of Engineering Tech Associates, P.A. These plans are for the one time use at the location and for the client listed. Engineering Tech Associates, P.A. assumes no liability for these plans if they are reproduced, in whole or in part, for construction at any other location without written permission from Engineering Tech Associates, P.A.

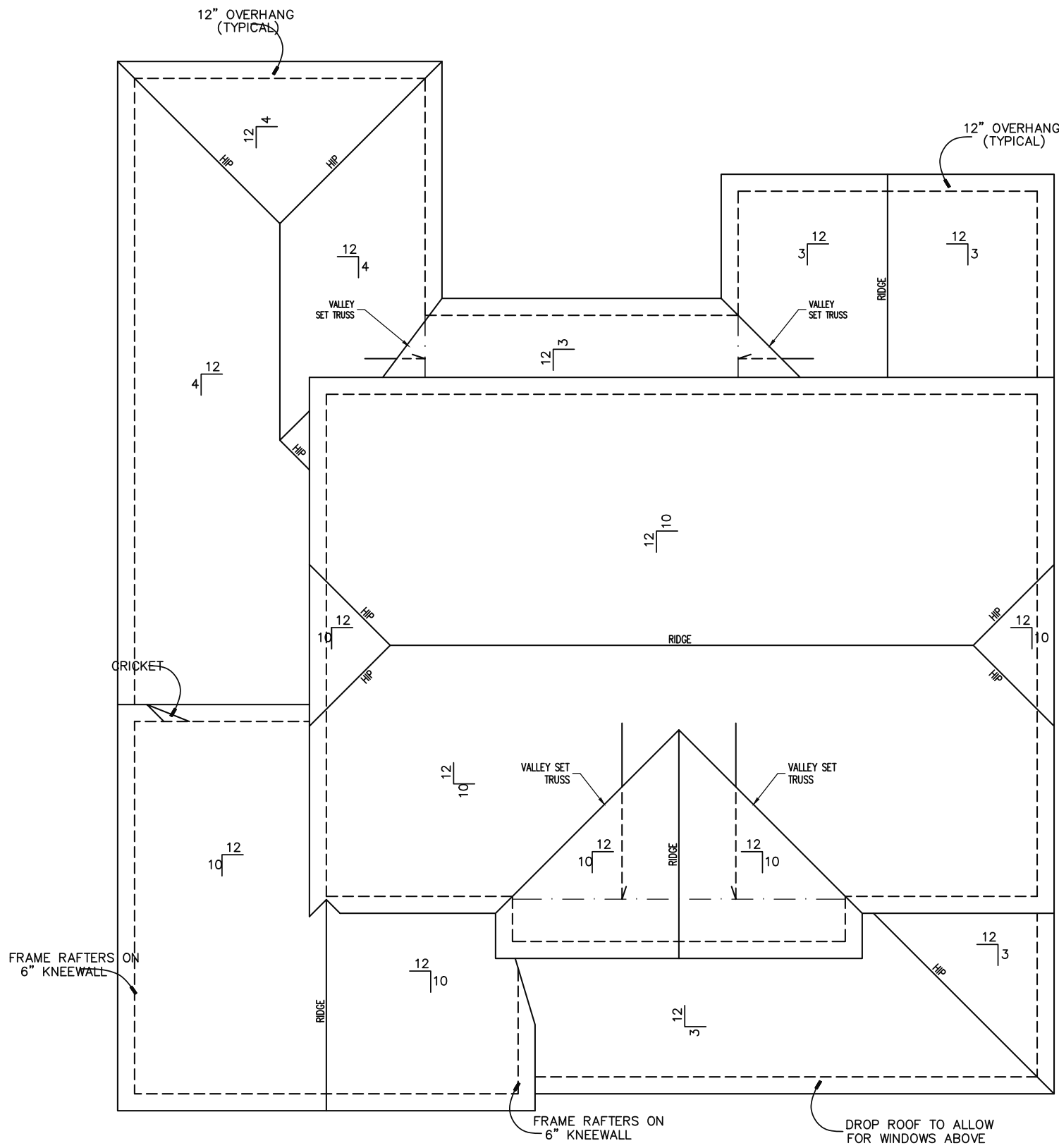
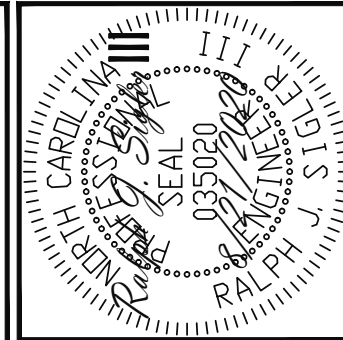

**TRUSS UPLIFT CONNECTORS**  
 EXPOSURE B, 120 MPH, ANY PITCH  
 24" O.C. MAX ROOF TRUSS SPACING

TRUSSES SHALL BE ATTACHED TO SUPPORT WALL FOR UPLIFT RESISTANCE. CONTINUOUS OSB WALL SHEATHING BELOW PROVIDES CONTINUOUS UPLIFT RESISTANCE TO FOUNDATION. ALL TRUSSES SUPPORTED BY INTERMEDIATE SUPPORT WALLS, KNEEWALLS OR BEAMS SHALL BE ATTACHED TO SUPPORTING MEMBER PER SCHEDULE BELOW.

ROOF SPAN IS MEASURED HORIZONTALLY BETWEEN FURTHEST SUPPORT POINTS.

ROOF SPAN UP TO 18'	CONNECTOR NAILING PER TABLE 602.3(1) NCRBC 2018 EDITION
OVER 18'	(1) SIMPSON H2.5A HURRICANE CLIP TO DBL TOP PLATE OR BEAM

**FRAMING NOTES**  
 ROOF ONLY

- ROOF TRUSSES PER TRUSS MANUFACTURER @ MAX 24" O.C.
- VERIFY ALL KNEEWALL HEIGHTS, ROOF PITCHES AND ARCHITECTURAL OVERHANGS PRIOR TO CONSTRUCTION

**ROOF FRAMING PLAN**  
 1/8" = 1'-0"

**Engineering Tech ASSOCIATES, P.A.**  
 STRUCTURAL ENGINEERS  
 License No. C-3870  
 183 Wind Chime Court, Suite 100  
 Raleigh, North Carolina 27615  
 ASSOCIATES, P.A. (919) 844-1661 Fax (919) 844-1665

CLIENT:	TRIPLE A HOMES
SCOPE:	STRUCTURAL ADDENDUM
LOT #:	3 CHRISTIAN LIGHT
ENG:	RJS/CMC
REV:	
DATE:	8/21/2020

PLAN NO.  
**VICTORIA 2020**

PROJECT NO.  
**20-28-028**

SHEET NO.  
**S5**

5 of 10



1/2" Ø ANCHOR BOLTS WITH MIN. OF 7" OF EMBEDMENT @ 6'-0" O.C., 12" FROM ENDS OF SOLE PLATE

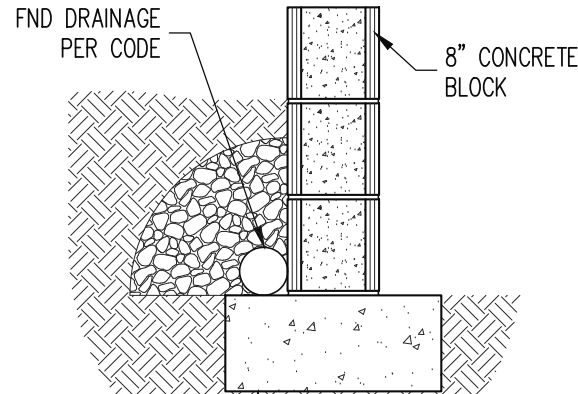
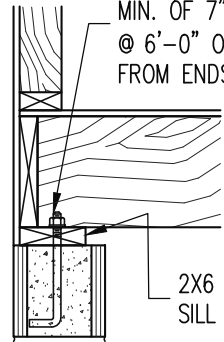

POURED CONCRETE FOOTING PER PLAN  
**1** SECTION  
 S1 TYPICAL FND WALL CRAWL SPACE  
 3/4" = 1'-0"

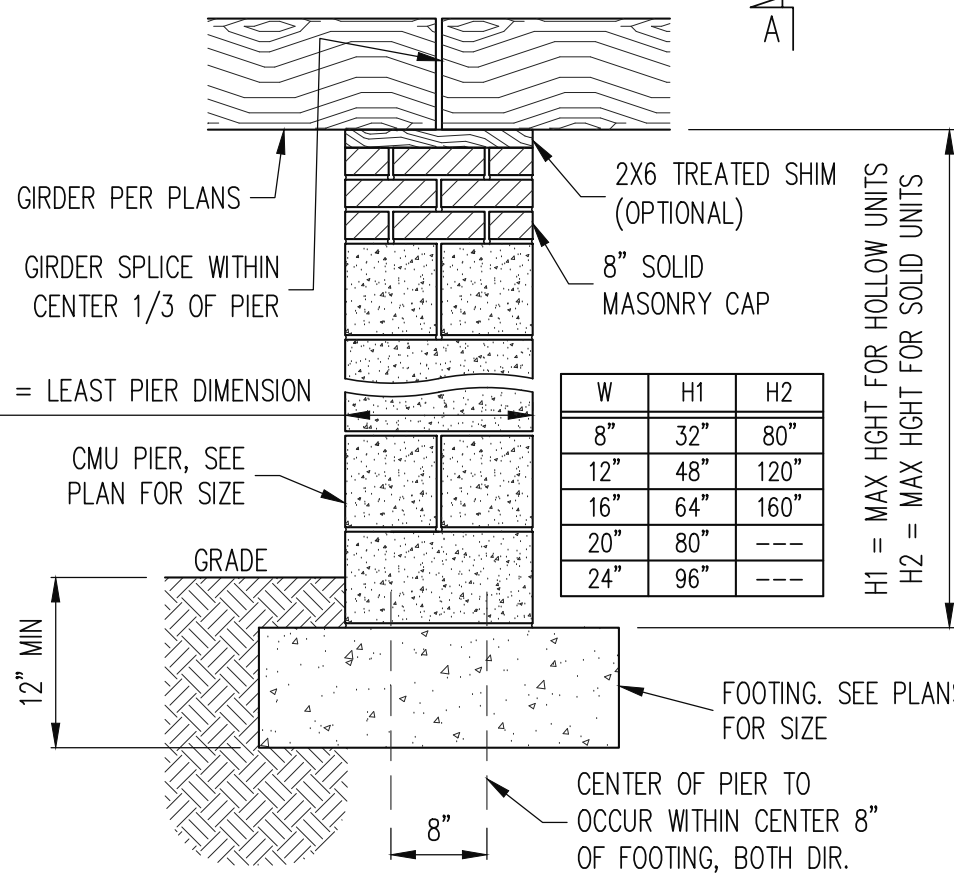

W	H1	H2
8"	32"	80"
12"	48"	120"
16"	64"	160"
20"	80"	---
24"	96"	---

**2** SECTION  
 S1 TYPICAL MASONRY PIER, GIRDER  
 3/4" = 1'-0"

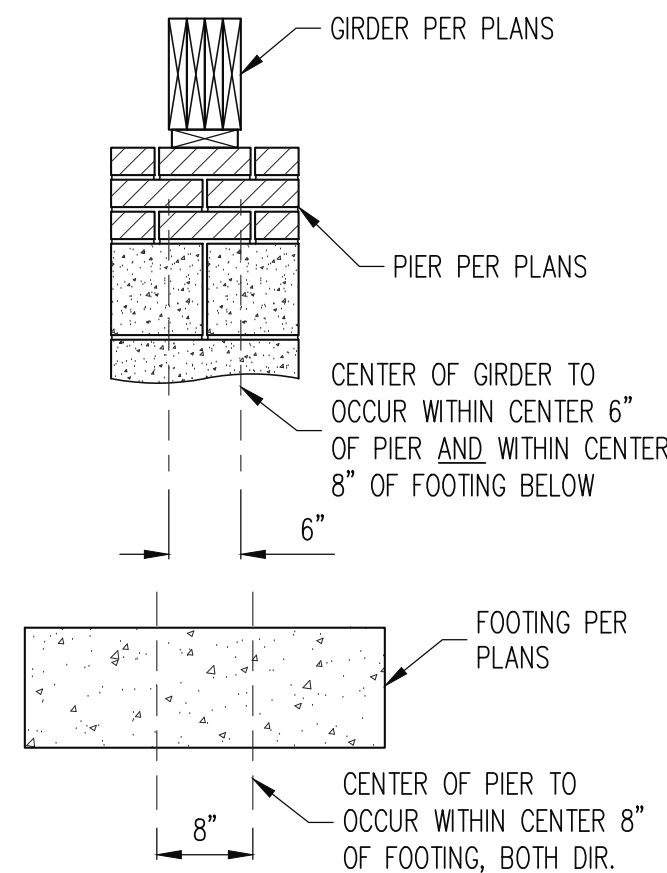

SECTION A-A  
 3/4" = 1'-0"

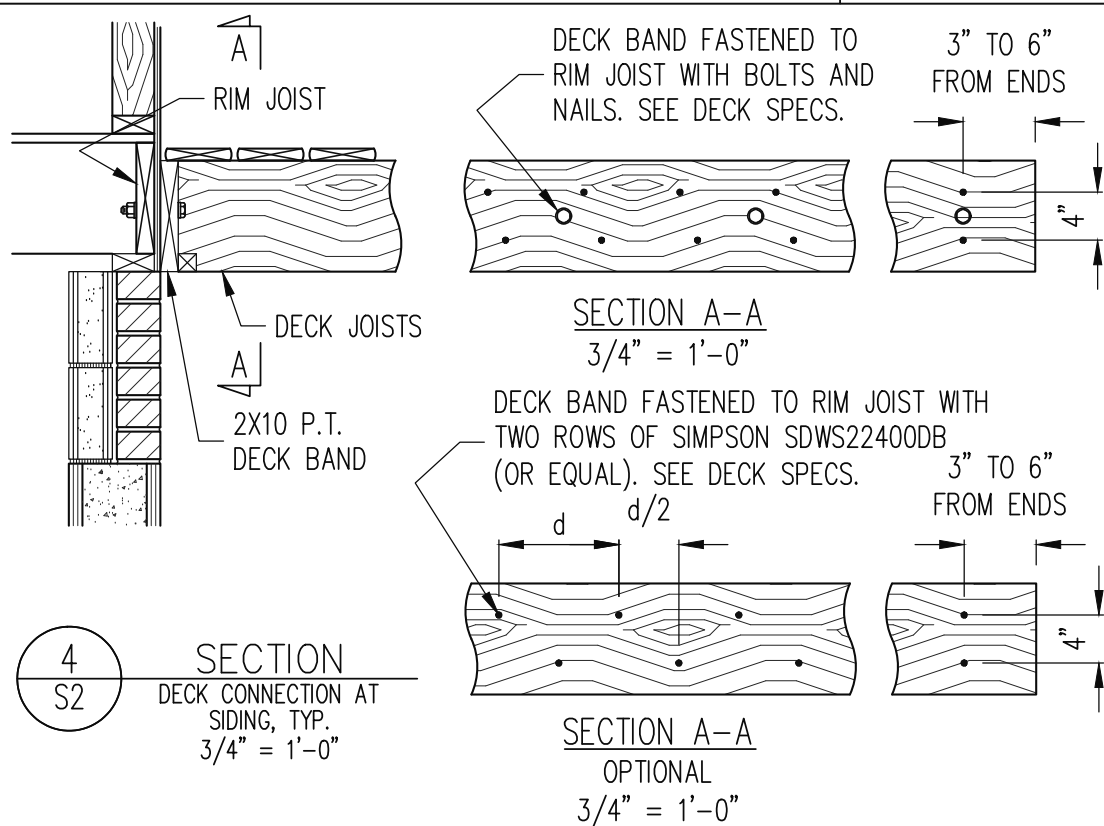

**4** SECTION  
 S2 DECK CONNECTION AT SIDING, TYP.  
 3/4" = 1'-0"

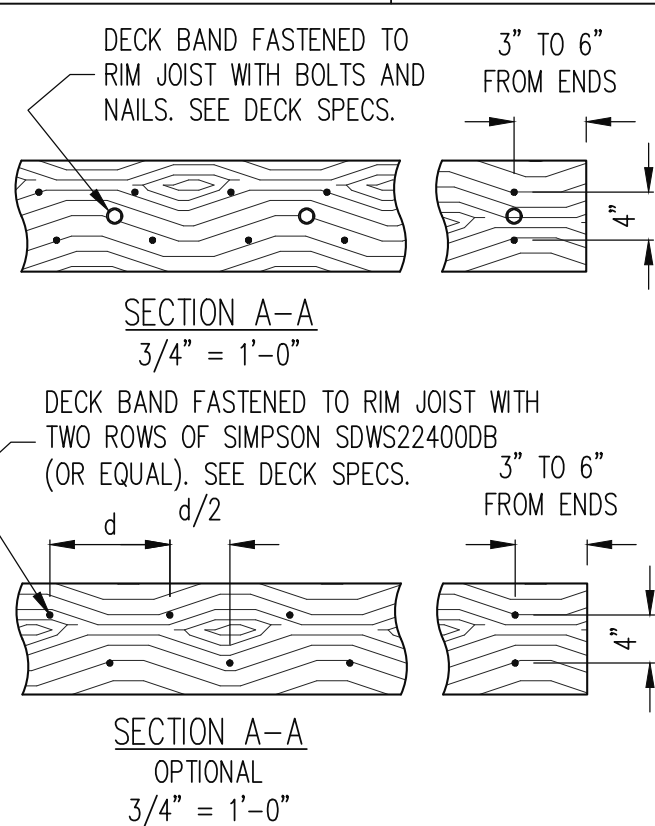

**3** SECTION  
 S2 TYPICAL DROPPED GIRDER  
 3/4" = 1'-0"

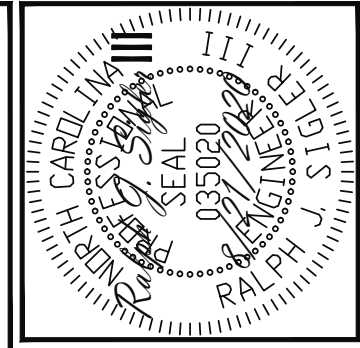

The structural design of this plan is the property of Engineering Tech Associates, P.A. These plans are for the one time use at the location and for the client listed. Engineering Tech Associates, P.A. assumes no liability for these plans if they are reproduced, in whole or in part, for construction at any other location without written permission from Engineering Tech Associates, P.A.

**Engineering Tech ASSOCIATES, P.A.**  
 STRUCTURAL ENGINEERS  
 License No. C-3870  
 183 Wind Chime Court, Suite 100  
 Raleigh, North Carolina 27615  
 (919) 844-1661 Fax (919) 844-1665

CLIENT:	TRIPLE A HOMES
SCOPE:	STRUCTURAL ADDENDUM
LOT #:	3 CHRISTIAN LIGHT
ENG:	RJS/CMC
REV:	
DATE:	8/21/2020

PLAN NO.  
 VICTORIA 2020

PROJECT NO.  
 20-28-028

SHEET NO.  
 SD1

6 of 10

CONTINUOUS ROOF SHEATHING.  
ATTACH TO PARALLEL ROOF  
TRUSSES WITH 8d NAILS @ 6" O.C.

ATTACH 2X6 BLOCKING TO  
DBL TOP PLATE WITH (3) 16d  
NAILS, TYP UNO.

FLAT 2X6 BLOCKING @ 16" O.C.  
BETWEEN PARALLEL TRUSSES. ATTACH  
EACH END TO ROOF TRUSS WITH (1)  
SIMP. L30 ANGLE, TYP UNO.

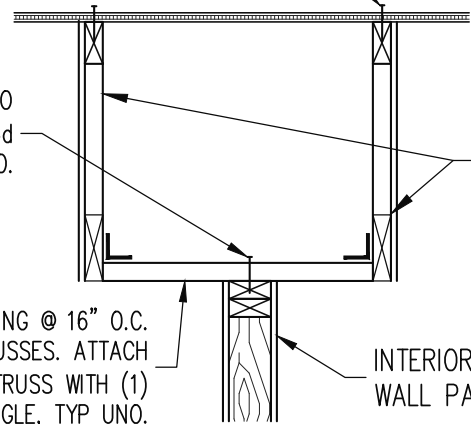

**5**  
SECTION  
S3 INTERIOR BRACED WALL WITH  
PARALLEL ROOF TRUSSES,  
NOT ABOVE WALL, TYP.  
3/4" = 1'-0"

1" THK OSB SHEATHING,  
1/2" SIDE OF TRUSS  
PARALLEL TO WALL.  
ATTACH TO TRUSS WITH  
8d NAILS AT 6" O.C. AT  
PANEL EDGES AND 12"  
O.C. IN PANEL FIELD.

INTERIOR BRACED  
WALL PANEL

ATTIC STYLE ROOF TRUSS PER MANU.

CUT DBL TOP PLATE OF  
SUPPORTING WALL. ADD (2)  
SIMP. CS16 STRAPS (48" LONG)

(2) 1.75" X 11.875" LVL. NAIL  
TOGETHER WITH (3) ROWS OF 12d  
NAILS @ 8" O.C., ROWS 3" APART

(2) 2X4 KING STUD EA SIDE. NAIL TO  
EA LVL WITH 12d NAILS @ 8" O.C.

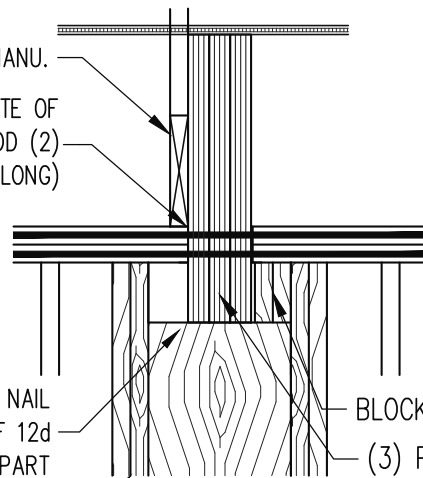

**6**  
SECTION  
S3 PARTIALLY DROPPED  
GARAGE BEAM  
3/4" = 1'-0"

BLOCKING TO POINT LOAD  
(3) PLY 24" LVL BEAM.

2X6 BLOCKING BETWEEN  
TRUSSES. ATTACH TO  
DBL TOP PLATE WITH 8d  
TOENAILS @ 6" O.C.  
ALONG BRACED WALL  
PANEL. TOENAIL  
BLOCKING TO TRUSS WITH  
(2) 8d NAILS, B.E.

CONTINUOUS ROOF  
SHEATHING

ENGINEERED ROOF  
TRUSS. SEE  
ARCHITECTURAL  
PLANS FOR  
OVERHANG DETAILS.

BRACED WALL PANEL

CONTINUOUS SHEATHING  
ATTACHED PER WALL  
BRACING NOTES.

(3) 16d NAILS @ 16" O.C.  
ALONG BRACED WALL  
PANEL

8d @ 6" O.C. ALONG  
BRACED WALL PANEL

(3) 16d NAILS @ 16" O.C.  
ALONG BRACED WALL  
PANEL

1/2"Ø ANCHOR BOLTS WITH  
MIN. OF 7" OF EMBEDMENT  
@ 6'-0" O.C., 12" FROM  
ENDS OF SOLE PLATE

FLOOR JOIST  
PER PLAN

2X6 P.T.  
SILL PLATE

**7**  
SECTION  
S3 TYPICAL BRACED WALL  
PANEL CONNECTION  
3/4" = 1'-0"

The structural design of this plan is the property  
of Engineering Tech Associates, P.A. These plans  
are for the one time use at the location and for  
the client listed. Engineering Tech Associates, P.A.  
assumes no liability for these plans if they are  
reproduced, in whole or in part, for construction  
at any other location without written permission  
from Engineering Tech Associates, P.A.

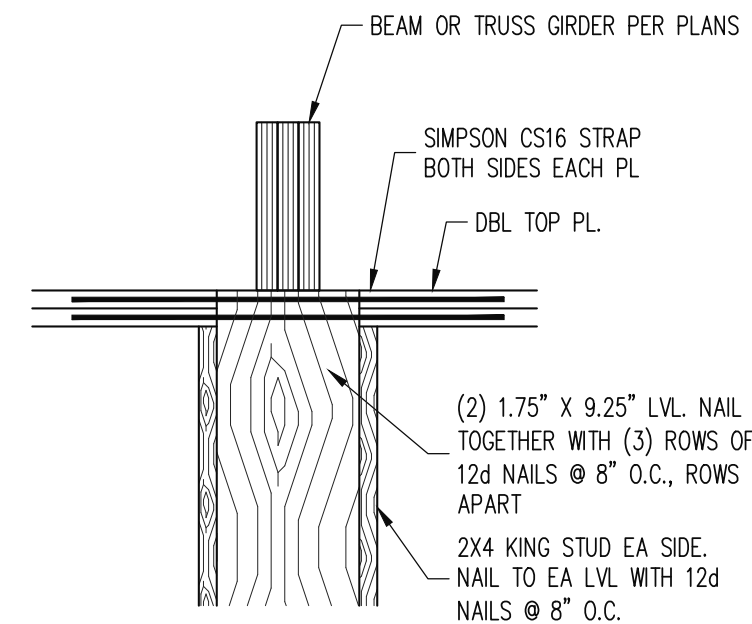
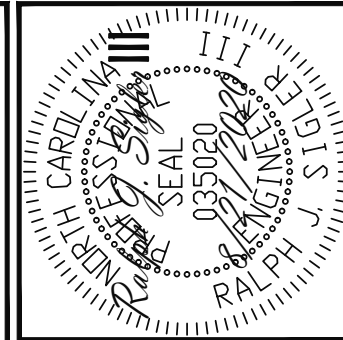

**8**  
SECTION  
S3 LVL COLUMN FOR FLUSH  
BEAM  
3/4" = 1'-0"

SIMPSON CS16 STRAP  
BOTH SIDES EACH PL

DBL TOP PL.

(2) 1.75" X 9.25" LVL. NAIL  
TOGETHER WITH (3) ROWS OF  
12d NAILS @ 8" O.C., ROWS 3"  
APART

2X4 KING STUD EA SIDE.  
NAIL TO EA LVL WITH 12d  
NAILS @ 8" O.C.

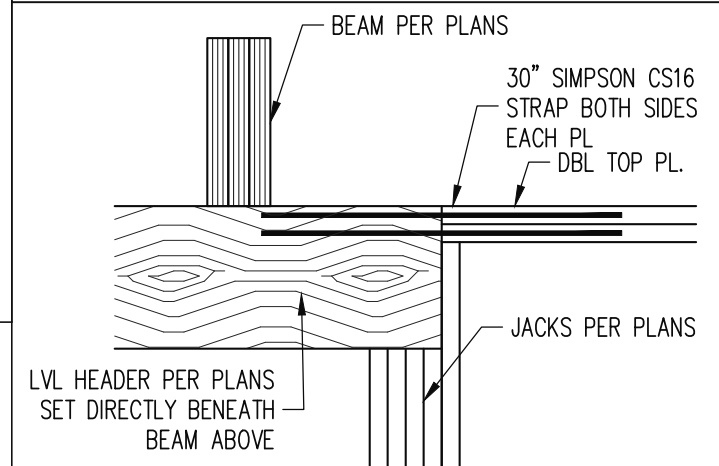

**9**  
SECTION  
S3 TOP FLUSH HEADER  
3/4" = 1'-0"

30" SIMPSON CS16  
STRAP BOTH SIDES  
EACH PL  
DBL TOP PL.

JACKS PER PLANS

LVL HEADER PER PLANS  
SET DIRECTLY BENEATH  
BEAM ABOVE

STRUCTURAL ENGINEERS  
License No. C-3870  
183 Wind Chime Court, Suite 100  
Raleigh, North Carolina 27615  
ASSOCIATES, P.A. (919) 844-1661 Fax (919) 844-1665

CLIENT:	TRIPLE A HOMES
SCOPE:	STRUCTURAL ADDENDUM
LOT #:	3 CHRISTIAN LIGHT
ENG:	RJS/CMC
REV:	
DATE:	8/21/2020

PLAN NO.  
VICTORIA 2020

PROJECT NO.  
20-28-028

SHEET NO.  
SD2

7 of 10

# DECK SPECIFICATIONS

- A DECK IS AN EXPOSED EXTERIOR WOOD FLOOR STRUCTURE WHICH MAY BE ATTACHED TO A STRUCTURE OR BE FREE STANDING. ROOFED PORCHES, OPEN OR SCREENED IN, MAY BE CONSTRUCTED USING THESE PROVISIONS.
- SUPPORT POSTS SHALL BE SUPPORTED BY A FOOTING.
- WHEN ATTACHED TO A STRUCTURE, THE STRUCTURE TO WHICH ATTACHED SHALL HAVE A TREATED WOOD BAND FOR THE LENGTH OF THE DECK, OR CORROSION RESISTANT FLASHING SHALL BE USED TO PREVENT MOISTURE FROM COMING IN CONTACT WITH THE UNTREATED FRAMING OF THE STRUCTURE. THE DECK BAND AND THE STRUCTURE BAND SHALL BE CONSTRUCTED IN CONTACT WITH EACH OTHER EXCEPT AT BRICK VENEER AND WHERE PLYWOOD SHEATHING IS REQUIRED AND PROPERLY FLASHED. SIDING SHALL NOT BE INSTALLED BETWEEN THE STRUCTURE AND THE DECK BAND. IF ATTACHED TO A BRICK STRUCTURE, NEITHER FLASHING NOR A TREATED BAND FOR THE BRICK STRUCTURE IS REQUIRED. IN ADDITION, THE TREATED DECK BAND SHALL BE CONSTRUCTED IN CONTACT WITH THE BRICK
- WHEN THE DECK IS SUPPORTED AT THE STRUCTURE BY ATTACHING THE DECK TO THE STRUCTURE, THE FOLLOWING ATTACHMENT SCHEDULES SHALL APPLY FOR ATTACHING THE DECK BAND TO THE STRUCTURE:
 

REQUIRED FASTENERS	JOIST LENGTH	
	UP TO 8' MAX.	UP TO 16' MAX.
ONE - 5/8" $\phi$ BOLT @ 42" O.C. AND (2) ROWS OF 12d NAILS @ 8" O.C. OR TWO ROWS OF SIMPSON SDWS22400DB @ d = 32" O.C. STAGGERED	ONE - 5/8" $\phi$ BOLT @ 42" O.C. AND (3) ROWS OF 12d NAILS @ 6" O.C. OR TWO ROWS OF SIMPSON SDWS22400DB @ d = 16" O.C. STAGGERED	ONE - 5/8" $\phi$ BOLT @ 20" O.C. AND (3) ROWS OF 12d NAILS @ 6" O.C. OR TWO ROWS OF SIMPSON SDWS22400DB @ d = 16" O.C. STAGGERED
- ALL STRUCTURES EXCEPT BRICK STRUCTURES
 

JOIST LENGTH	
UP TO 8' MAX.	UP TO 16' MAX.
REQUIRED FASTENERS	ONE - 5/8" $\phi$ BOLT @ 28" O.C.
- IF THE DECK BAND IS SUPPORTED BY A 1/2" MINIMUM MASONRY LEDGE ALONG THE FOUNDATION WALL, 5/8"  $\phi$  BOLTS SPACED @ 48" O.C. MAY BE USED FOR SUPPORT.
- OTHER MEANS OF SUPPORT, SUCH AS JOIST HANGERS, MAY BE USED TO CONNECT DECK JOISTS TO A TREATED STRUCTURE BAND
- GIRDERS SHALL BEAR DIRECTLY ON POSTS OR BE CONNECTED TO THE SIDES OF POSTS WITH 2 - 5/8"  $\phi$  BOLTS
- FLOOR DECKING SHALL BE NO. 2 GRADE TREATED SOUTHERN PINE OR EQUIVALENT. THE MINIMUM FLOOR DECKING THICKNESS SHALL BE AS FOLLOWS:

JOIST SPAN	DECKING
12" O.C.	1" S4S
16" O.C.	1" T&G
24" O.C.	1 1/4" S4S
32" O.C.	2" S4S

9. MAXIMUM HEIGHT OF DECK SUPPORT POSTS IS AS FOLLOWS:

POST SIZE	MAX POST HEIGHT
4X4	8'
6X6	20'
ENGINEERED	20' +

- NOTES: 1) THIS TABLE IS BASED ON NO. 2 TREATED SOUTHERN PINE POSTS.  
 2) THIS TABLE IS BASED ON A MAXIMUM TRIBUTARY AREA OF 128 SQ. FT.  
 3) POST HEIGHT IS FROM TOP OF FOOTING TO BOTTOM OF GIRDER.
10. DECKS SHALL BE BRACED TO PROVIDE LATERAL STABILITY BY ONE OF THE FOLLOWING METHODS:
- WHEN THE DECK FLOOR HEIGHT IS LESS THAN 4'-0" AND THE DECK IS ATTACHED TO THE STRUCTURE IN ACCORDANCE WITH SECTION 4, LATERAL BRACING IS NOT REQUIRED.
  - 4X4 WOOD KNEE BRACES MAY BE PROVIDED ON EACH COLUMN IN BOTH DIRECTIONS. THE KNEE BRACES SHALL ATTACH TO EACH POST AT A POINT NOT LESS THAN 1/3 OF THE POST LENGTH FROM THE TOP OF THE POST, AND THE BRACES SHALL BE ANGLED BETWEEN 45° AND 60° FROM THE HORIZONTAL. KNEE BRACES SHALL BE ATTACHED AT THE ENDS TO THE GIRDER AND THE POST WITH ONE - 5/8"  $\phi$  BOLT
  - FOR FREE STANDING DECKS WITHOUT KNEE BRACES OR DIAGONAL BRACING, LATERAL STABILITY MAY BE PROVIDED BY EMBEDDING THE POSTS IN CONCRETE IN ACCORDANCE WITH THE FOLLOWING:
 

POST SIZE	TRIBUT. AREA	POST HEIGHT	EMB. DEPTH	CONC. DIAM.
4X4	48 SQ. FT.	4'-0"	2'-6"	1'-0"
6X6	120 SQ. FT.	6'-0"	3'-6"	1'-8"
  - 2X6 DIAGONAL VERTICAL CROSS BRACING SHALL BE PROVIDED IN TWO PERPENDICULAR DIRECTIONS FOR FREE STANDING DECKS OR PARALLEL TO THE STRUCTURE AT THE EXTERIOR COLUMN LINE FOR ATTACHED DECKS. THE BRACES SHALL BE ATTACHED TO THE POSTS WITH ONE - 5/8"  $\phi$  BOLT AT EACH END OF THE BRACE.
 

NOTES: 1) ALL NAILS AND BOLTS ARE TO BE HOT DIPPED GALVANIZED.  
 2) MINIMUM EDGE DISTANCE FOR BOLTS IS 2 1/2".  
 3) NAILS MUST PENETRATE THE SUPPORTING STRUCTURE BAND A MINIMUM OF 1 1/2".

## ALLOWABLE I-JOIST SUBSTITUTION

NOTE: MAINTAIN JOIST DEPTH, DIRECTION, AND SPACING SPECIFIED ON PLANS.

MANUFACTURER	DEPTH	SERIES	SIMPSON FACE MOUNT HGR	SIMPSON TOP FLANGE HGR
BLUELINX	11.875"	BLI 40	IUS2.56/11.88	ITS2.56/11.88
BOISE CASCADE INTERNATIONAL BEAMS	11.875"	BCI 6000s	IUS2.37/11.88	ITS2.37/11.88
	11.875"	IB 400	IUS2.56/11.88	ITS2.56/11.88
LP CORP	11.875"	LPI 20+	IUS2.56/11.88	ITS2.56/11.88
NORDIC	11.875"	NI 40X	IUS2.56/11.88	ITS2.56/11.88
ROSEBURG	11.875"	RFPI 40s	IUS2.56/11.88	ITS2.56/11.88
WEYERHAEUSER	11.875"	TJ 210	IUS2.06/11.88	ITS2.06/11.88
WEYERHAEUSER	11.875"	EEL-20	IUS2.37/11.88	ITS2.37/11.88
BLUELINX	16"	BLI 40	IUS2.56/16	ITS2.56/16
BLUELINX	16"	BLI 60	IUS2.56/16	ITS2.56/16
BOISE CASCADE	16"	BCI 5000s	IUS2.06/16	ITS2.06/16
BOISE CASCADE	16"	BCI 6000S	IUS2.37/16	ITS2.37/16
INTERNATIONAL BEAMS	16"	IB 600	IUS2.56/16	ITS2.56/16
LP CORP	16"	LPI 20+	IUS2.56/16	ITS2.56/16
NORDIC	16"	NI 40X	IUS2.56/16	ITS2.56/16
ROSEBURG	16"	RFPI 60S	IUS2.56/16	ITS2.56/16
WEYERHAEUSER	16"	TJ 210	IUS2.06/16	ITS2.06/16

JOISTS NOT LISTED IN THE ABOVE TABLE MAY BE USED PROVIDED THEY MEET OR EXCEED THE PROPERTIES OF THOSE LISTED. SUBSTITUTE USP BRAND HANGERS WITH EQUIVALENT VALUES AS DESIRED.

- THE BUILDER IS RESPONSIBLE FOR REVIEWING PLANS PRIOR TO CONSTRUCTION. THE BUILDER SHALL IMMEDIATELY CONTACT THE ENGINEER OF RECORD (EOR) BEFORE PROCEEDING IF THE FOLLOWING CONDITIONS ARE NOTED BEFORE OR DURING CONSTRUCTION:
- THE WORKING PLANS DO NOT BEAR THE SEAL OF THE EOR
  - THE PLANS CONTAIN DISCREPANT OR INCOMPLETE INFORMATION

ANY ERRORS DUE TO A FAILURE TO FOLLOW THE ABOVE PROCEDURES SHALL NOT BE THE RESPONSIBILITY OF THE EOR. FURTHERMORE, IT IS THE RESPONSIBILITY OF THE BUILDER TO ENSURE THAN ANY REVISIONS ISSUED BY THE EOR ARE PROMPLY DISTRIBUTED TO THE SUBCONTRACTORS

THE EOR DOES NOT PERFORM FENESTRATION OR VENTING CALCULATIONS OR ANY OTHER CALCULATIONS THAT ARE NOT DIRECTLY RELATED TO STRUCTURAL ENGINEERING.

ROOF AND FLOOR TRUSSES TO BE DESIGNED BY AN ENGINEER REGISTERED BY THE STATE. FINAL TRUSS DRAWING SHOULD BE SUBMITTED TO THE EOR FOR REVIEW

## ABBREVIATIONS

ABV	ABOVE	FND	FOUNDATION	TJ	TRIPLE JOIST
B.	BOTH	FTG	FOOTING	TYP	TYPICAL
B.E.	BOTH ENDS	HDC	HOT DIPPED GALVANIZED	TRPL	TRIPLE
BTWN	BETWEEN	HGR	HANGER	TSP	TRIPLE STUD POCKET
CIP	CAST IN PLACE	LVL	LAMINATED VENEER LUMBER	UNO	UNLESS NOTED OTHERWISE
CONC	CONCRETE	NTS	NOT TO SCALE	XJ	EXTRA JOIST
CS	CONTINUOUS SHEATHING	O.C.	ON CENTER		
DIA	DIAMETER	PSL	PARALLEL STRAND LUMBER		
DBL	DOUBLE	PT	PRESSURE TREATED		
DJ	DOUBLE JOIST	QJ	QUAD JOIST		
DSP	DBL STUD POCKET	SP	STUD POCKET		
EQ	EQUAL	SQ	SQUARE		
EA	EACH				
FLG	FLANGE				
FL PL	FLITCH PLATE				
FLR	FLOOR				

## NOTES

The structural design of this plan is the property of Engineering Tech Associates, P.A. These plans are for the one time use at the location and for the client listed. Engineering Tech Associates, P.A. assumes no liability for these plans if they are reproduced, in whole or in part, for construction at any other location without written permission from Engineering Tech Associates, P.A.

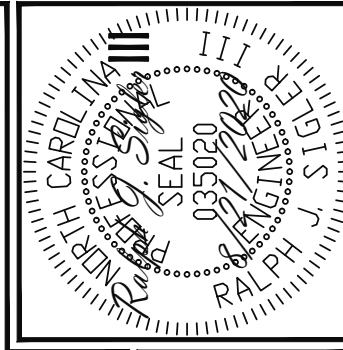

**Engineering Tech ASSOCIATES, P. A.**  
**STRUCTURAL ENGINEERS**  
 License No. C-3870  
 183 Wind Chime Court, Suite 100  
 Raleigh, North Carolina 27615  
 (919) 844-1661 Fax (919) 844-1665

CLIENT:	TRIPLE A HOMES
SCOPE	STRUCTURAL ADDENDUM
LOT #:	3 CHRISTIAN LIGHT
ENG:	RJS/CMC
REV:	
DATE:	8/21/2020

PLAN NO.  
VICTORIA 2020

PROJECT NO.  
20-28-028

SHEET NO.  
SD3

The structural design of this plan is the property of Engineering Tech Associates, P.A. These plans are for the one time use at the location and for the client listed. Engineering Tech Associates, P.A. assumes no liability for these plans if they are reproduced, in whole or in part, for construction at any other location without written permission from Engineering Tech Associates, P.A.

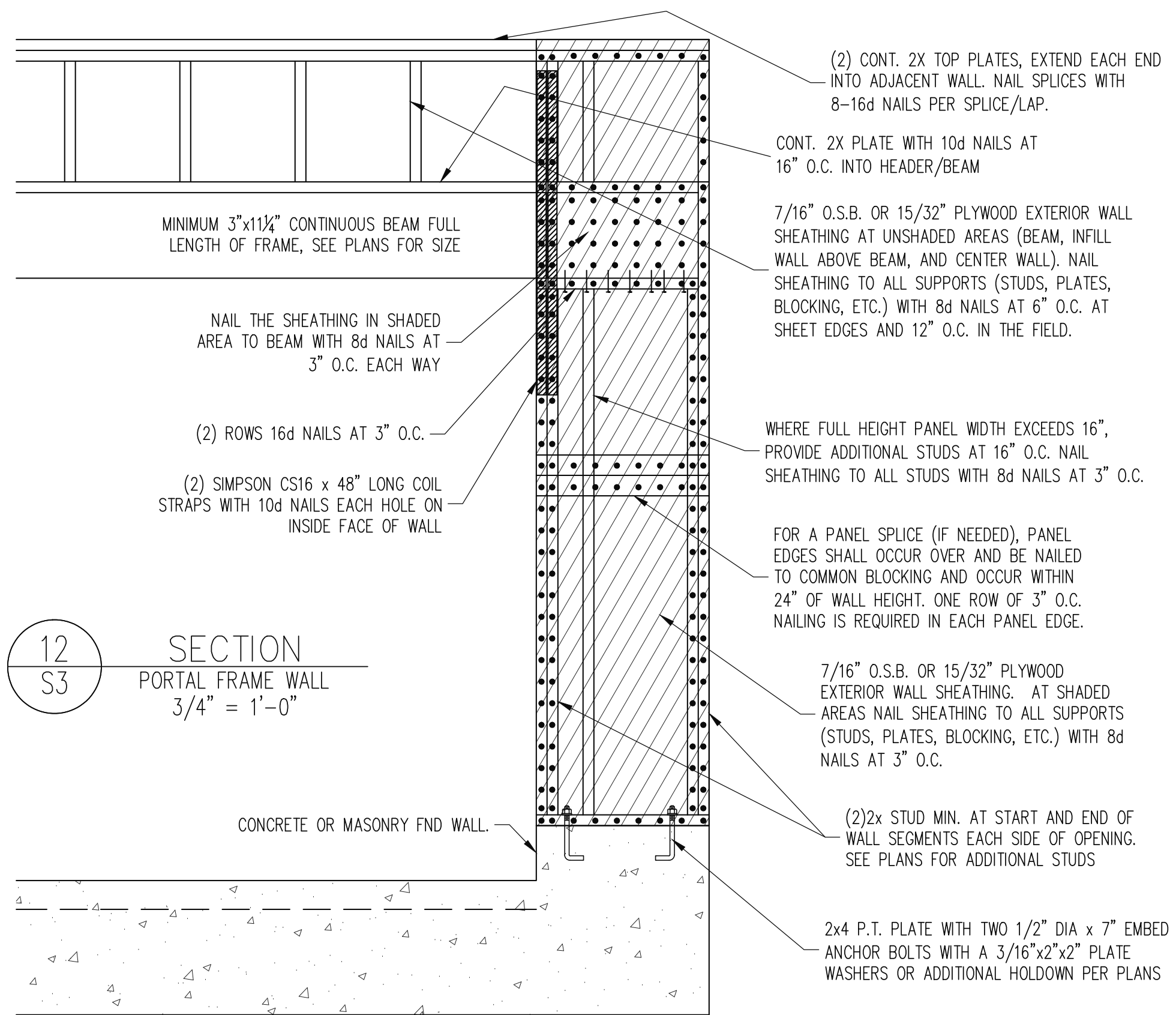
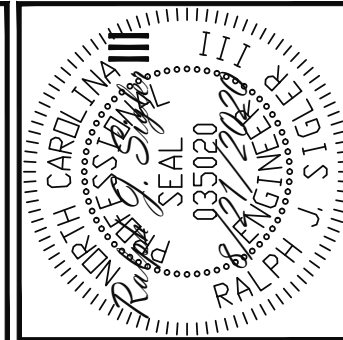

12  
S3

SECTION  
PORTAL FRAME WALL  
3/4" = 1'-0"

(2) CONT. 2X TOP PLATES, EXTEND EACH END INTO ADJACENT WALL. NAIL SPLICES WITH 8-16d NAILS PER SPLICE/LAP.

CONT. 2X PLATE WITH 10d NAILS AT 16" O.C. INTO HEADER/BREAM

MINIMUM 3"x11 1/4" CONTINUOUS BEAM FULL LENGTH OF FRAME, SEE PLANS FOR SIZE

7/16" O.S.B. OR 15/32" PLYWOOD EXTERIOR WALL SHEATHING AT UNSHADED AREAS (BEAM, INFILL WALL ABOVE BEAM, AND CENTER WALL). NAIL SHEATHING TO ALL SUPPORTS (STUDS, PLATES, BLOCKING, ETC.) WITH 8d NAILS AT 6" O.C. AT SHEET EDGES AND 12" O.C. IN THE FIELD.

NAIL THE SHEATHING IN SHADED AREA TO BEAM WITH 8d NAILS AT 3" O.C. EACH WAY

WHERE FULL HEIGHT PANEL WIDTH EXCEEDS 16", PROVIDE ADDITIONAL STUDS AT 16" O.C. NAIL SHEATHING TO ALL STUDS WITH 8d NAILS AT 3" O.C.

(2) ROWS 16d NAILS AT 3" O.C.

(2) SIMPSON CS16 x 48" LONG COIL STRAPS WITH 10d NAILS EACH HOLE ON INSIDE FACE OF WALL

FOR A PANEL SPLICE (IF NEEDED), PANEL EDGES SHALL OCCUR OVER AND BE NAILED TO COMMON BLOCKING AND OCCUR WITHIN 24" OF WALL HEIGHT. ONE ROW OF 3" O.C. NAILING IS REQUIRED IN EACH PANEL EDGE.

7/16" O.S.B. OR 15/32" PLYWOOD EXTERIOR WALL SHEATHING. AT SHADED AREAS NAIL SHEATHING TO ALL SUPPORTS (STUDS, PLATES, BLOCKING, ETC.) WITH 8d NAILS AT 3" O.C.

CONCRETE OR MASONRY FND WALL.

(2)2x STUD MIN. AT START AND END OF WALL SEGMENTS EACH SIDE OF OPENING. SEE PLANS FOR ADDITIONAL STUDS

2x4 P.T. PLATE WITH TWO 1/2" DIA x 7" EMBED ANCHOR BOLTS WITH A 3/16"x2"x2" PLATE WASHERS OR ADDITIONAL HOLDOWN PER PLANS

STRUCTURAL ENGINEERS  
License No. C-3870  
183 Wind Chime Court, Suite 100  
Raleigh, North Carolina 27615  
ASSOCIATES, P.A. (919) 844-1661 Fax (919) 844-1665

CLIENT:	TRIPLE A HOMES	ENG:	RJS/CMC	REV:	DATE
SCOPE	STRUCTURAL ADDENDUM				
LOT #:	3 CHRISTIAN LIGHT				

PLAN NO.  
VICTORIA 2020

PROJECT NO.  
20-28-028

SHEET NO.  
SD4

9 of 10

# CONSTRUCTION SPECIFICATIONS

PART 1: GENERAL

- 1.01 CONSTRUCTION SHALL MEET THE REQUIREMENTS OF THE NORTH CAROLINA RESIDENTIAL CODE, 2018 EDITION.
- 1.02 DIMENSIONS SHOWN SHALL GOVERN OVER SCALE ON THESE DRAWINGS.
- 1.05 METHODS, PROCEDURES AND SEQUENCES OF CONSTRUCTION ARE THE RESPONSIBILITY OF THE CONTRACTOR, WHO SHALL TAKE ALL NECESSARY PRECAUTIONS TO MAINTAIN AND INSURE THE INTEGRITY OF THE STRUCTURE AT ALL STAGES OF CONSTRUCTION.

PART 2: DESIGN LOADS

2.01 DESIGN LOADS SHALL CONFORM WITH THE TABLE BELOW:

USE	LIVE LOAD (PSF)	DEAD LOAD (PSF)
BALCONIES, DECKS, ATTICS WITH FIXED STAIR ACCESS, DWELLING UNITS INCLUDING ATTICS WITH FIXED STAIR ACCESS, STAIRS, FIRE ESCAPES	40	10
GARAGES (PASSENGER CARS ONLY)	50	--
ATTICS (NO STORAGE, LESS THAN 5' HEADROOM)	10	10
ATTICS (WITH STORAGE)	20	10
ROOF	20	10 (15 FOR VAULTS)

NOTES: - INDIVIDUAL STAIR TREADS ARE TO BE DESIGNED FOR THE UNIFORMLY DISTRIBUTED LIVE LOAD OF 40 PSF OR A 300 LB. CONCENTRATED LOAD ACTING OVER AN AREA OF 4 SQ. WHICHEVER PRODUCES THE GREATER STRESS.  
 - BUILDER TO VERIFY DEAD LOAD DOES NOT EXCEED 10 PSF WHEN HEAVY FLOOR OR ROOF FINISHES SUCH AS TILE OR SLATE ARE UTILIZED. NOTIFY ENGINEERING UNDER THESE CONDITIONS

- 2.02 INTERIOR WALLS: 5 PSF LATERAL.
- 2.03 BASIC WIND DESIGN VELOCITY OF 120 MPH.
- 2.04 SOIL BEARING CAPACITY 2000 PSF (PRESUMPTIVE).

PART 5: CONCRETE AND SLABS ON GRADE

- 5.01 CAST IN PLACE CONCRETE SHALL BE OF NORMAL WEIGHT, 6% AIR ENTRAINMENT, AND SHALL HAVE A MINIMUM COMPRESSIVE STRENGTH OF 3000 PSI AT 28 DAYS TYP UNO. ALL CONCRETE, INCLUDING CONCRETE FOR FOOTINGS, IS TO BE CAST IN PLACE, TYP UNO.
- 5.03 SLABS ON GRADE, IF ANY, SHALL CONTAIN SYNTHETIC POLYPROPYLENE FIBRILLATED MICRO FIBERS, FIBER LENGTH 1 1/2", DOSAGE RATE 1 1/2 LBS/CU YD. SLAB TO BE PLACED ON A 6 MIL VAPOR BARRIER ON 2" MIN GRANULAR FILL ON SOIL WITH 90% MIN STANDARD PROCTOR DENSITY. VAPOR BARRIER MAY BE OMITTED FOR SLABS NOT IN ENCLOSED AREAS

PART 7: MASONRY

- 7.01 CONCRETE MASONRY UNITS SHALL CONFORM TO ASTM C90 AND C55, NORMAL WEIGHT, f'm = 1,500 PSI MIN
- 7.02 CLAY MASONRY UNITS SHALL CONFORM TO ASTM C62-17 GRADE SW
- 7.03 MORTAR SHALL BE TYPE S. MORTAR AND GROUT SHALL CONFORM TO ASTM C476, MIN COMPRESSIVE STRENGTH OF 2000 PSI.
- 7.04 MASONRY CONSTRUCTION SHALL CONFORM TO THE SPECIFICATIONS OF ACI 530
- 7.05 LADDER WIRE REINFORCEMENT SHALL CONFORM TO ASTM A951. 6" MIN LAPS FOR CONTINUOUS WALL APPLICATIONS

PART 8: BOLTS AND LAG SCREWS

8.03 ANCHOR RODS AND BOLTS SHALL CONFORM TO ASTM F1554-15 GRADE 36 UNO. BENT ANCHOR BOLTS SHALL HAVE A 2" MIN HOOK UNO

PART 9: DRIVEN FASTENERS

9.01 NAILS, SPIKES AND STAPLES SHALL CONFORM TO ASTM F 1667-05. NAILS ARE TO BE COMMON WIRE OR BOX

PART 10: DIMENSIONAL LUMBER

10.01 SOLID SAWN WOOD FRAMING DESIGN IS BASED ON NO. 2 SPRUCE PINE FIR OR SYP #2 FOR JOISTS, RAFTERS, GIRDERS, BEAMS, STUDS, ETC.

PART 11: ENGINEERED LUMBER

- 11.01 LVL OR PSL MINIMUM ALLOWABLE DESIGN STRESSES ARE AS FOLLOWS:  
 E= 1.9 X 10E6 PSI, Fb = 2600 PSI, Fv = 285 PSI, Fc = 750 PSI  
 LSL MINIMUM ALLOWABLE DESIGN STRESSES ARE AS FOLLOWS:  
 E= 1.3 X 10E6 PSI, Fb = 1700 PSI, Fv = 400 PSI, Fc = 680 PSI
- 11.02 LVL OR PSL MEMBERS MAY BE RIPPED FROM DEEPER MEMBERS TO MATCH THE MEMBER DEPTH SPECIFIED IN THE PLANS

PART 12: PRESSURE TREATED LUMBER

12.01 LUMBER IN CONTACT WITH THE GROUND, CONCRETE OR MASONRY SHALL BE PRESSURE TREATED IN ACCORDANCE WITH AWPA STANDARD C-15. ALL OTHER EXPOSED LUMBER SHALL BE TREATED IN ACCORDANCE WITH AWPA STANDARD C-2 OR BY ANY METHOD GIVING EQUAL PROTECTION. THE BUILDING CODE OFFICE MAY ALSO APPROVE A NATURAL DECAY RESISTANT WOOD PER SECTION 19-6(A)

PART 14: STUD SUPPORTS FOR BEAMS

- 14.01 STEEL, ENGINEERED LUMBER, AND FLITCH PLATE BEAMS BEARING ON A STUD WALL SHALL BEAR AS FOLLOWS:  
 1-WHEN THE BEAM IS PERPENDICULAR TO, OR SKEWED RELATIVE TO THE WALL, THE BEAM SHALL BEAR FULL WIDTH ON THE SUPPORTING WALL INDICATED AND SHALL BE SUPPORTED BY A MINIMUM OF THREE GANGED STUDS, OR A GANGED STUD COLUMN WITH A NUMBER OF STUDS SUCH THAT THE STUD COLUMN IS AT LEAST AS WIDE AS THE TRUE WIDTH OF THE BEAM BEING SUPPORTED, WHICHEVER IS GREATER, TYP UNO. FOR THE SKEWED CONDITION PARTICULAR CARE SHALL BE TAKEN TO ENSURE STUD COLUMN IS CENTERED ON THE BEAM  
 2-BEAMS BEARING ONTO THE END OF A STUD WALL PARALLEL TO THE BEAM SHALL BEAR A MINIMUM OF 4 1/2" ONTO THE WALL AND BE SUPPORTED BY A TRPL STUD GANGED COLUMN TYP UNO.

- 14.02 DIMENSIONAL LUMBER BEAMS BEARING ON A STUD WALL SHALL BEAR AS FOLLOWS:  
 1-WHEN THE BEAM IS PERPENDICULAR TO, OR SKEWED RELATIVE TO THE WALL, THE BEAM SHALL BEAR FULL WIDTH ON THE SUPPORTING WALL INDICATED (LESS 1 1/2" TO ALLOW FOR A CONTINUOUS RIM JOIST WHERE APPLICABLE) AND SHALL BE SUPPORTED BY A GANGED STUD COLUMN THE SAME WIDTH AS THE BEAM TYP UNO. (E.G. A TRIPLE 2X10 IS TO BE SUPPORTED BY (3) STUDS). FOR THE SKEWED CONDITION PARTICULAR CARE SHALL BE TAKEN TO ENSURE STUD COLUMN IS CENTERED ON THE BEAM  
 2-BEAMS BEARING ONTO THE END OF A STUD WALL PARALLEL TO THE BEAM SHALL BEAR A MINIMUM OF 3" ONTO THE WALL AND BE SUPPORTED BY A DBL STUD GANGED COLUMN TYP UNO.

14.03 EXTRA JOISTS BEARING ON A STUD WALL PERPENDICULAR TO OR SKEWED RELATIVE TO THE BEAM SHALL BE SUPPORTED BY ONE ADDITIONAL STUD.

14.04 STUDS THAT ARE GANGED TO FORM A COLUMN SHALL HAVE ADJACENT STUDS WITHIN THE COLUMN NAILED TOGETHER WITH ONE ROW OF 10d NAILS AT 8" O.C. (TWO ROWS OF 10d NAILS @ 8" O.C., 3" APART, FOR 2X8 OR 2X10 STUDS) ALL COLUMNS SHALL BE CONTINUOUS DOWN TO THE FOUNDATION OR OTHER PROPERLY DESIGNED STRUCTURAL ELEMENT SUCH AS A BEAM. COLUMNS TRANSFERRING LOADS THROUGH FLOOR LEVELS SHALL BE SOLIDLY BLOCKED FOR THE FULL WIDTH OF THE STUD COLUMN WITHIN THE CAVITY FORMED BY THE FLOOR JOISTS.

PART 15: NAILING OF MULTI PLY WOOD BEAMS

15.01 SOLID SAWN LUMBER JOISTS THAT ARE GANGED TO FORM A BEAM SHALL HAVE ADJACENT MEMBERS IN THE BEAM NAILED TOGETHER WITH THREE ROWS OF 10d NAILS @ 16" O.C. FOR 2X10 OR LARGER, TWO ROWS OF 10d NAILS @ 16" O.C. FOR 2X8, ONE ROW OF 10d NAILS @ 16" O.C. FOR 2X6 OR SMALLER. STAGGER ROWS 5" MIN.

15.02 LVL MEMBERS THAT ARE GANGED TO FORM A BEAM SHALL HAVE ADJACENT MEMBERS IN THE BEAM FASTENED TOGETHER PER MANUFACTURERS RECOMMENDATIONS, TYP UNO

PART 16: WALL FRAMING AND BRACING

- 16.01 STUD WALLS SHALL CONSIST OF 2X4 STUDS SPACED AT 16" O.C. UNO. STUDS SHALL BE CONTINUOUS FROM SOLE PLATE AT FLOOR TO DOUBLE TOP PLATE AT THE CEILING OR ROOF. NO INTERMEDIATE BANDS OR PLATES SHALL CAUSE DISCONTINUITIES IN A STUD WALL EXCEPT AS REQUIRED FOR DOOR OR WINDOW OPENINGS. THE KING STUDS FOR SUCH OPENINGS SHALL BE CONTINUOUS, TYP UNO.  
**MAX ALLOWABLE WALL HEIGHTS** FOR EXTERIOR STUD WALLS, WITH SOLE PLATE AND DBL TOP PLATE AND 7/16" OSB EXTERIOR BRACING AND ROW OF 2X4 / 2X6 PURLINS AT 8' HEIGHT (AND AT 16' HEIGHT FOR TALL WALLS), TYP UNO:  
 2X4 @ 16" O.C.: 11'-0"    2X6 @ 16" O.C.: 17'-0"  
 2X4 @ 12" O.C.: 12'-0"    2X6 @ 12" O.C.: 18'-8"  
 DBL 2X4 @ 16" O.C.: 13'-4"    DBL 2X6 @ 16" O.C.: 21'-0"

- 16.02 FOR WALL BRACING THE FOLLOWING SHALL APPLY:  
 -BLOCKING AT UNSUPPORTED PANEL EDGES IS REQUIRED TYP UNO.  
 -WALL BRACING IS BY ENGINEERED DESIGN AND NOT PRESCRIPTIVE PER SECTION 602.10 OF THE 2018 NCR. CONTINUOUS SHEATHING HAS BEEN PROVIDED, ALONG WITH ALTERNATIVE METHODS TO INSURE THE MINIMUM INTENT OF SECTION 602.10 OF THE 2018 NCR HAS BEEN MET AND EXCEEDED.  
 -BRACED WALL PANELS SHALL BE FASTENED IN ACCORDANCE WITH TABLE 602.3(1) TO PROVIDE CONTINUOUS PANEL UPLIFT RESISTANCE AND COMPLIANCE WITH NCRBC R602.3.5 AND R802.11 UNLESS NOTED OTHERWISE ON STRUCTURAL PLANS.  
 -MAY SUBSTITUTE WSP FOR GB  
 -SINGLE JOIST, CONTINUOUS RIM JOIST, OR BLOCKING OF EQUAL DEPTH IS REQUIRED ABOVE AND BELOW ALL BRACED WALLS. NAIL BLOCKING ABOVE WALL TO TOP PLATE WITH 16d TOE NAILS @ 6" O.C. NAIL SOLE PLATE OF BRACED WALL TO BLOCKING BELOW WITH (3) 16d NAILS @ 16" O.C. BLOCKING AT HORIZONTAL JOINTS IN BRACED WALL LINES ONLY REQUIRED AT SHADED WALLS, UNO.

PART 17: KING STUDS

17.01 KING STUDS FOR OPENINGS IN EXTERIOR WALLS SHALL BE AS FOLLOWS:

MAX OPENING WIDTH	NUMBER OF KING STUDS				
	5'-0"	9'-0"	13'-0"	17'-0"	21'-0"
2X4	1	2	3	4	5
STUD SIZE 2X6	1	1	2	2	2
2X8	1	1	1	1	2

PART 18: SUBSTITUTIONS

18.01 MATERIAL OR MEMBER SIZE SUBSTITUTIONS OR PLAN DEVIATIONS REQUIRE THE WRITTEN AUTHORIZATION OF THE DESIGNERS. UNAUTHORIZED DEVIATIONS ARE THE SOLE RESPONSIBILITY OF THE CONTRACTOR.

PART 19: OWNERSHIP OF STRUCTURAL DESIGN

19.01 THE STRUCTURAL DESIGN OF THIS PLAN IS THE PROPERTY OF ENGINEERING TECH ASSOCIATES (ETA). THESE PLANS ARE FOR THE ONE TIME USE AT THE LOCATION INDICATED AND FOR THE CLIENT LISTED. ETA ASSUMES NO LIABILITY FOR THESE PLANS IF THEY ARE REPRODUCED, IN WHOLE OR IN PART, FOR CONSTRUCTION AT ANY OTHER LOCATION WITHOUT WRITTEN PERMISSION FROM ETA

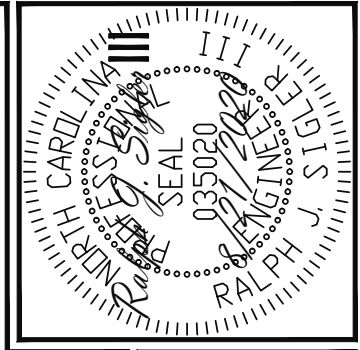

The structural design of this plan is the property of Engineering Tech Associates, P.A. These plans are for the one time use at the location and for the client listed. Engineering Tech Associates, P.A. assumes no liability for these plans, if they are reproduced, in whole or in part, for construction at any other location without written permission from Engineering Tech Associates, P.A.

**Engineering Tech**  
**STRUCTURAL ENGINEERS**  
 License No. C-3870  
 183 Wind Chime Court, Suite 100  
 Raleigh, North Carolina 27615  
 ASSOCIATES, P.A. (919) 844-1661 Fax (919) 844-1665

CLIENT:	TRIPLE A HOMES		
SCOPE	STRUCTURAL ADDENDUM	ENG: RJS/CMC	REV:
LOT #:	3 CHRISTIAN LIGHT	DATE: 8/21/2020	

**PLAN NO.**  
**VICTORIA 2020**

**PROJECT NO.**  
**20-28-028**

**SHEET NO.**  
**SD5**

**10 of 10**

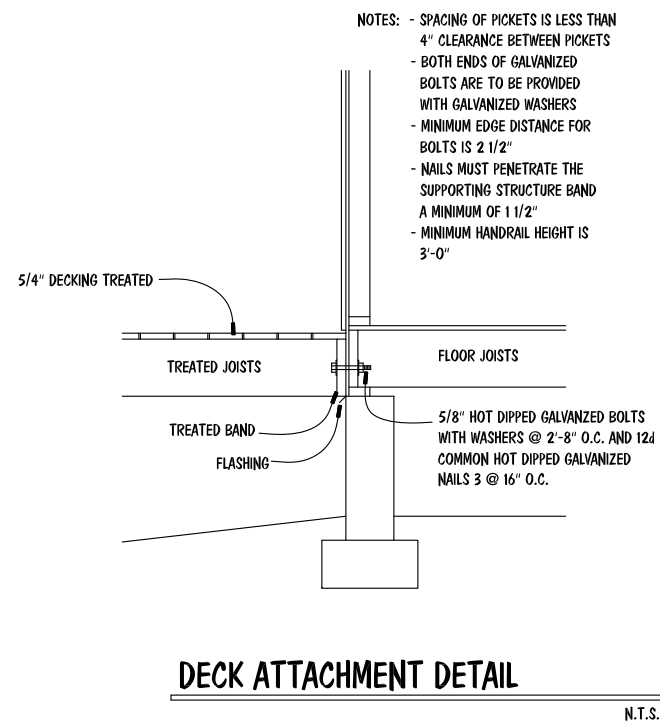
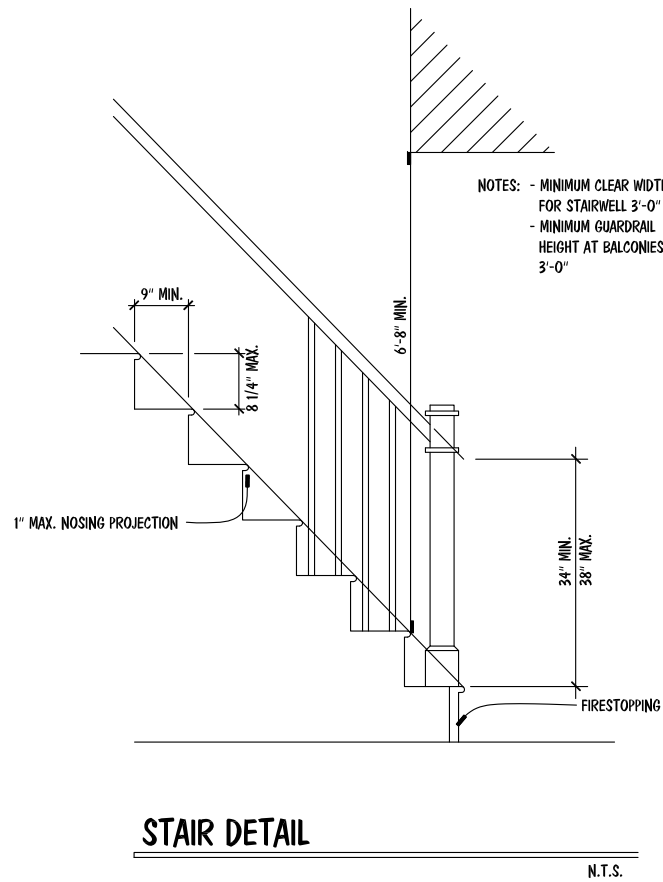
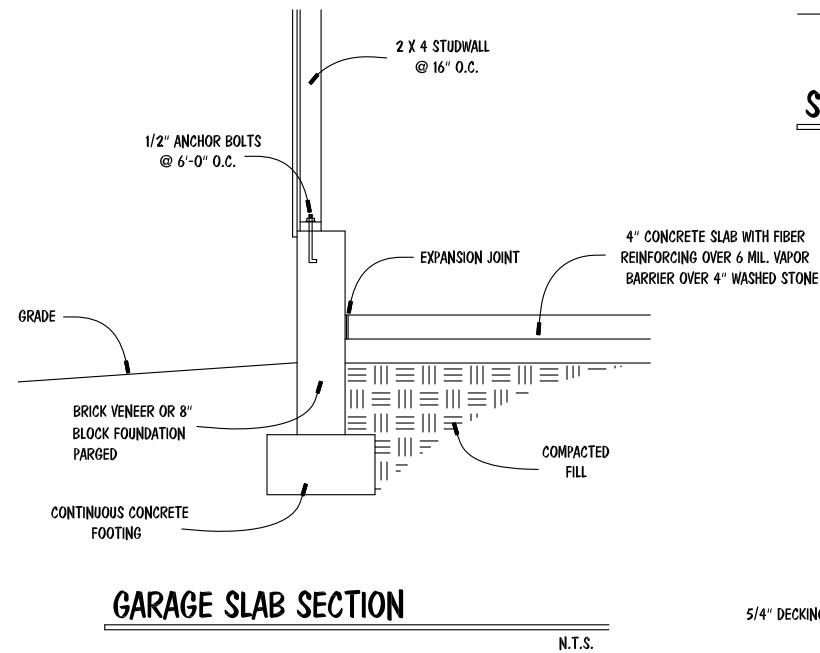

INSULATION VALUES	
WALLS	R-15
FLOORS	R-19
CEILING	R-38

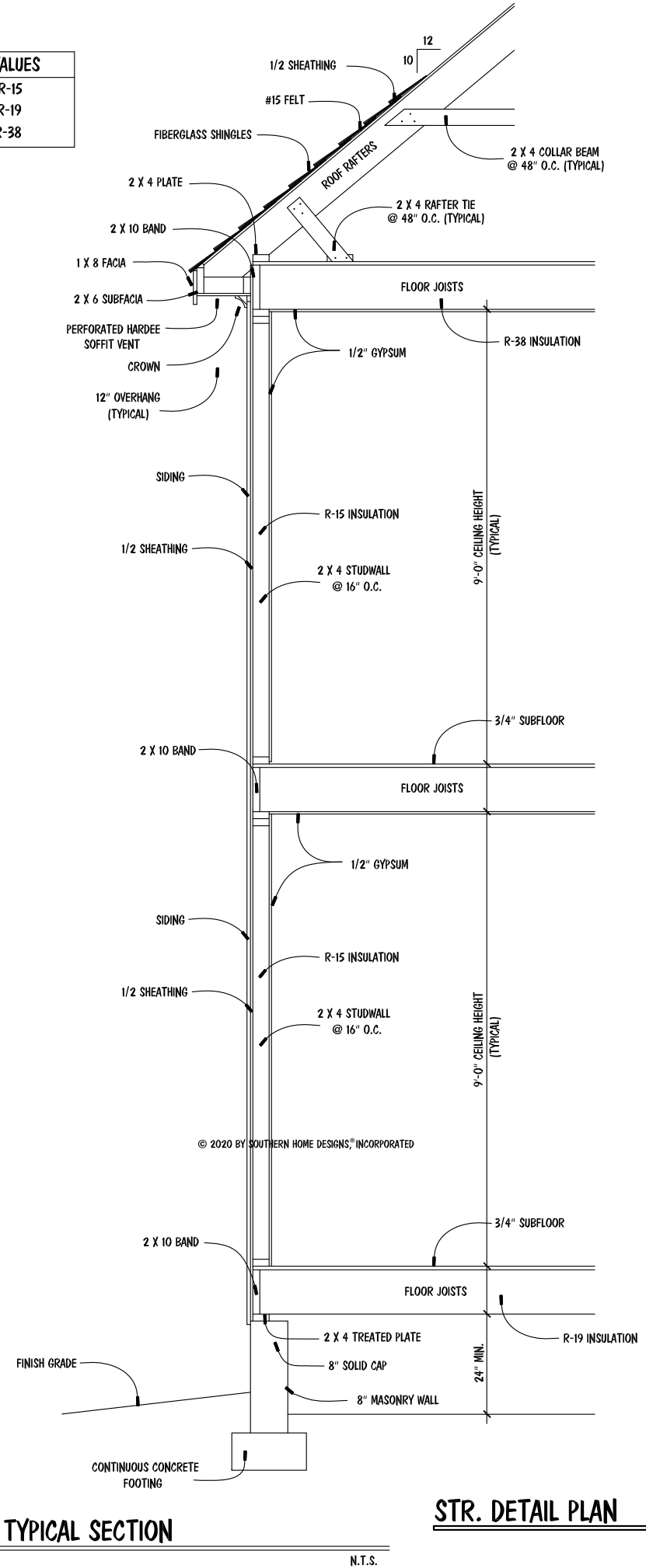

**STR. DETAIL PLAN**

© 2020 BY SOUTHERN HOME DESIGNS, INCORPORATED  
THESE PLANS ARE PROTECTED UNDER FEDERAL COPYRIGHT LAWS.  
THE ORIGINAL PURCHASER OF THESE PLANS IS LICENSED TO USE  
THE PLANS FOR THE CONSTRUCTION OF ONE AND ONLY ONE  
SINGLE FAMILY HOME. REPRODUCTION, MODIFICATION, OR REUSE  
OF THESE PLANS WITHOUT THE WRITTEN CONSENT OF SOUTHERN  
HOME DESIGNS, INCORPORATED, IS EXPRESSLY PROHIBITED.

**Houseplan Works.com**  
ALL DIMENSIONS AND SITE DIMENSIONS ARE TO BE VERIFIED  
BEFORE CONSTRUCTION BEGINS. ONCE CONSTRUCTION HAS  
BEGUN SOUTHERN HOME DESIGNS, INCORPORATED, IS RELEASED  
FROM ANY FURTHER RESPONSIBILITIES.

**Southern Home Designs**  
INCORPORATED  
301 South Salem Street, Suite 101, Apex, NC 27502  
919.380.7400 Office 919.380.7464 Fax  
Web: shdplans.com Email: shd@ncrr.com

THE  
VICTORIA 2020  
LOT 3 CHRISTIAN LIGHT

**TRIPLE A  
HOMES, INC.**

ENGR. #:  
DATE: 08-01-20  
SHEET: A-4  
PLAN #: 20-080120