

This layout and associated materials list has been prepared based on project plans and/or information provided to Builders FirstSource (BFS). It remains the responsibility of the builder, architect, designer, or other responsible persons to review this information to assure that it is appropriate, accurate, complete and complies with applicable building codes.

- GENERAL NOTES:**
- 1.) READ THE INSTALLATION GUIDE BEFORE FRAMING.
 - 2.) ALL WALLS SHOWN ARE LOAD BEARING UNLESS NOTED OTHERWISE. WALLS NOT SHOWN ARE CONSIDERED NON-LOAD BEARING.
 - 3.) UNLESS STATED OTHERWISE ALL CEILING & ROOF LOADS BRACE DIRECTLY TO LOAD BEARING WALLS SUPPORTED BY FOUNDATION.
 - 4.) CONTACT BUILDERS FIRSTSOURCE BEFORE MAKING ANY ALTERATIONS OR ADJUSTMENTS...FAILURE TO DO SO MAY RESULT IN COSTLY REPAIRS.

PlotID	Length	Product	Plies	Net Qty
FJ-1	36' 8"	14" BCI@ 4500s-1.8	1	5
FJ-2	24' 7 1/2"	14" BCI@ 4500s-1.8	1	3
FJ-3	18' 7 1/4"	14" BCI@ 4500s-1.8	1	5
FJ-4	18' 5 1/2"	14" BCI@ 4500s-1.8	1	8
FJ-5-2	18' 5 1/2"	14" BCI@ 4500s-1.8	2	2
FJ-6	16' 7 1/2"	14" BCI@ 4500s-1.8	1	4
FJ-7	16' 6 3/4"	14" BCI@ 4500s-1.8	1	2
FJ-8	15' 8 1/2"	14" BCI@ 4500s-1.8	1	4
FJ-9	15' 6 3/4"	14" BCI@ 4500s-1.8	1	8
FJ-10	14' 5 1/2"	14" BCI@ 4500s-1.8	1	6
FJ-11	8' 2 1/2"	14" BCI@ 4500s-1.8	1	1
FJ-12-2	8' 1 1/4"	14" BCI@ 4500s-1.8	2	2
FJ-13-2	5' 10 3/4"	14" BCI@ 4500s-1.8	2	2
FJ-14-2	4' 6"	14" BCI@ 4500s-1.8	2	2
FJ-15	4' 0 3/4"	14" BCI@ 4500s-1.8	1	1
FB1-2	22' 0"	1-3/4" x 14" VERSA-LAM® 2.0 3100 SP	2	2
FB2-3	20' 0"	1-3/4" x 18" VERSA-LAM® 2.0 3100 SP	3	3
Rim1	12' 0"	1" x 14" BC RIM BOARD OSB	1	16
Bk1	7' 0"	14" BCI@ 4500s-1.8	1	1

Hangers			
PlotID	Qty	Manuf	Product
H1	4	Simpson	HU 14
H2	30	Simpson	IUS 1.81/14
H3	2	Simpson	MIU 3.56/14

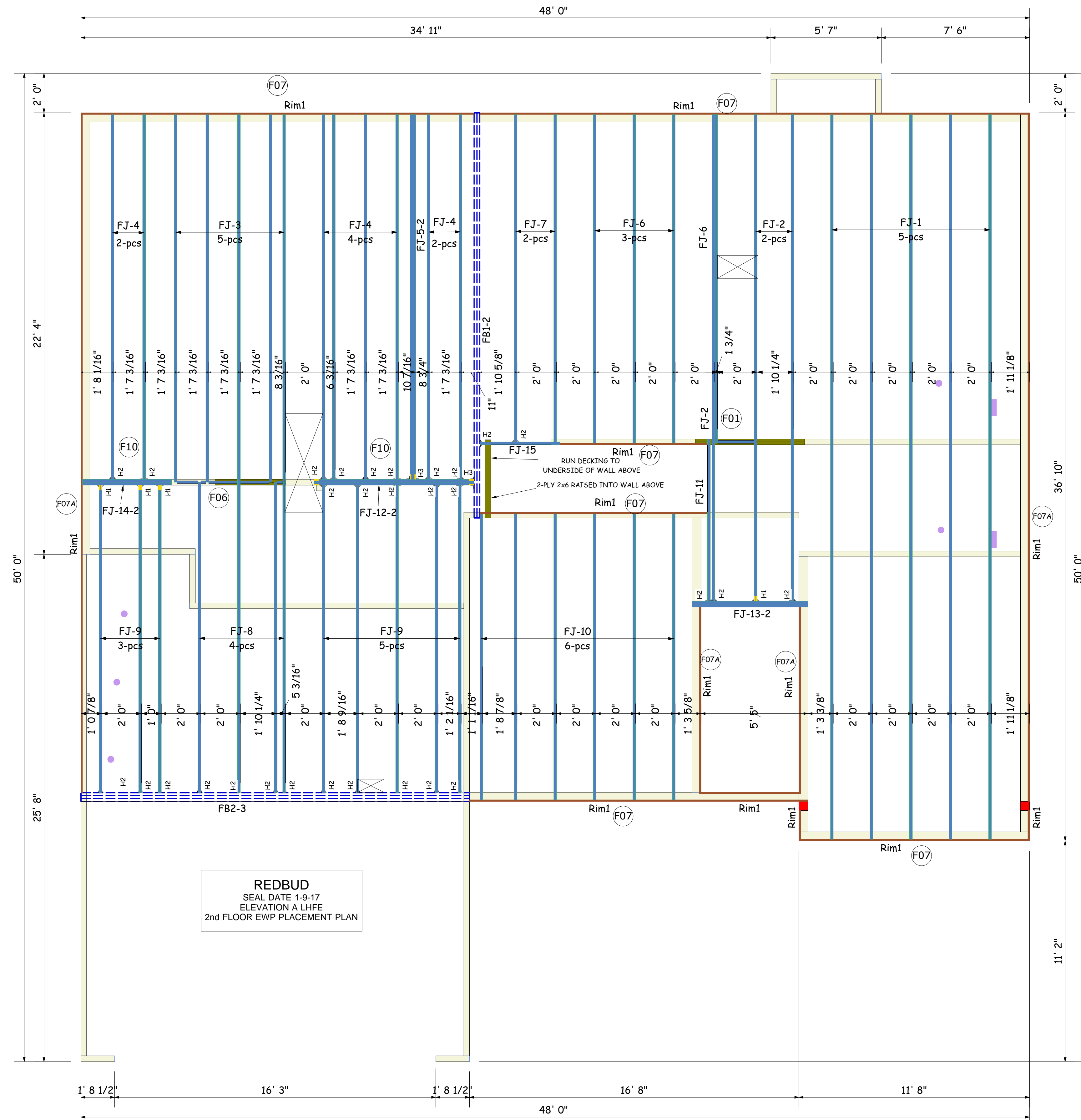

REDBUD
SEAL DATE 1-9-17
ELEVATION A LHFE
2nd FLOOR EWP PLACEMENT PLAN

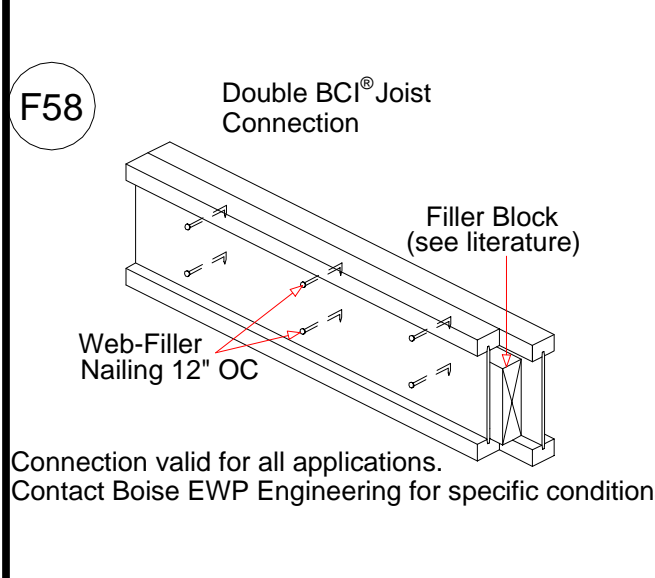
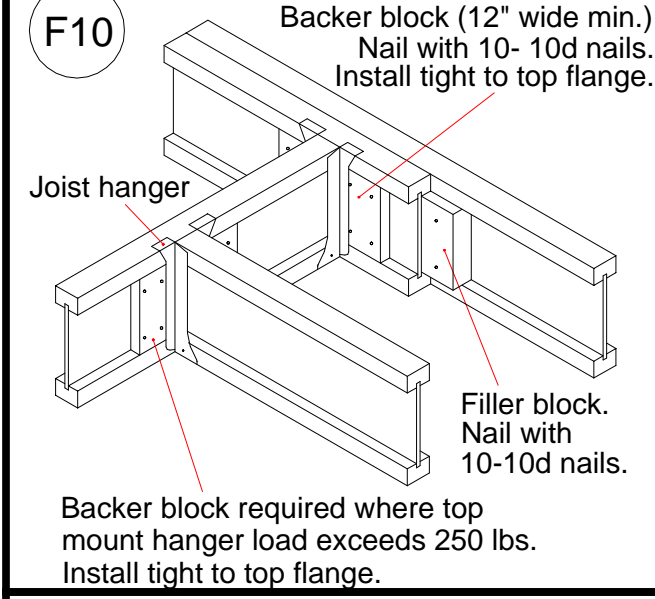
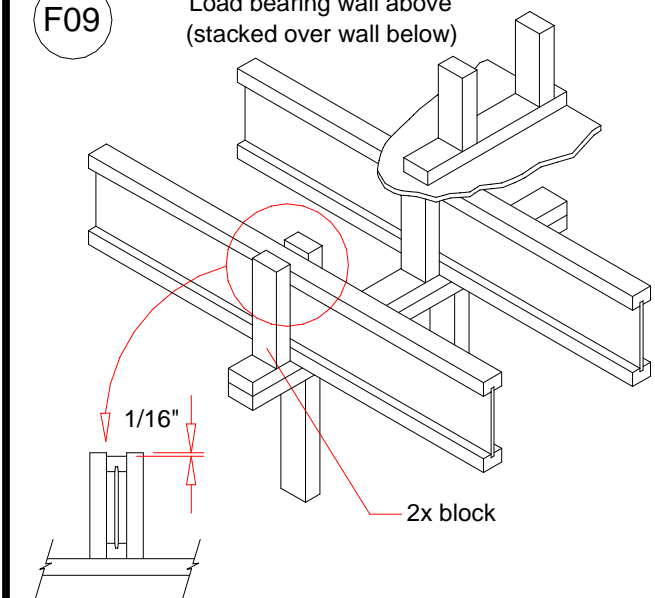
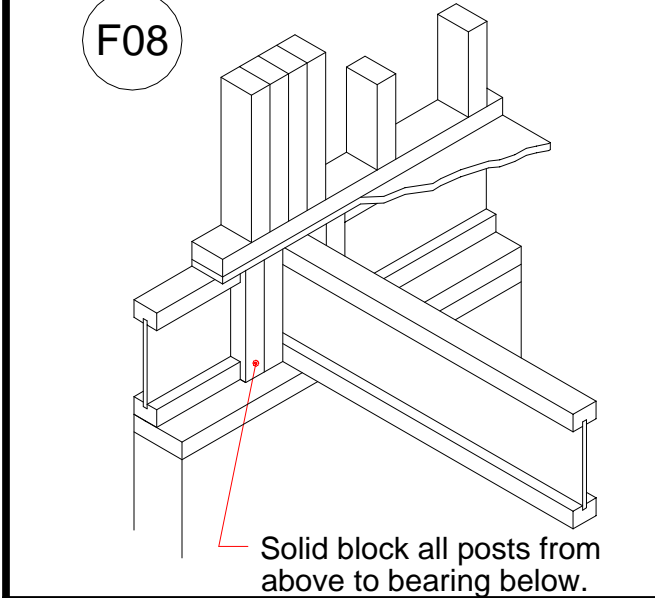
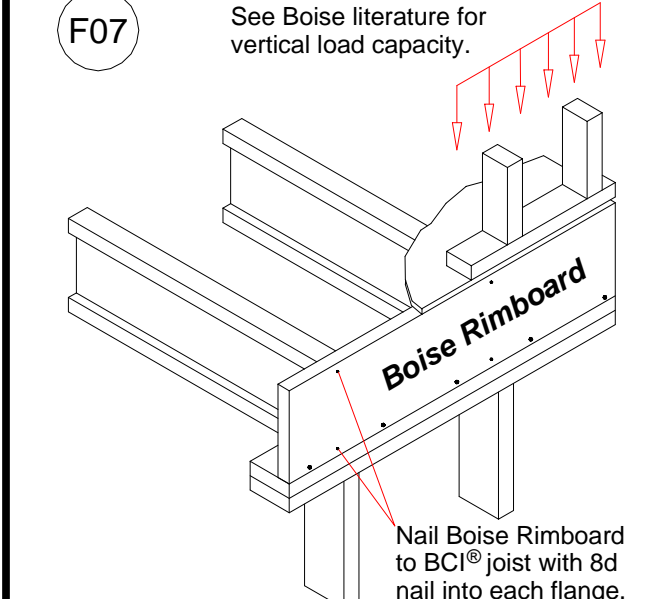
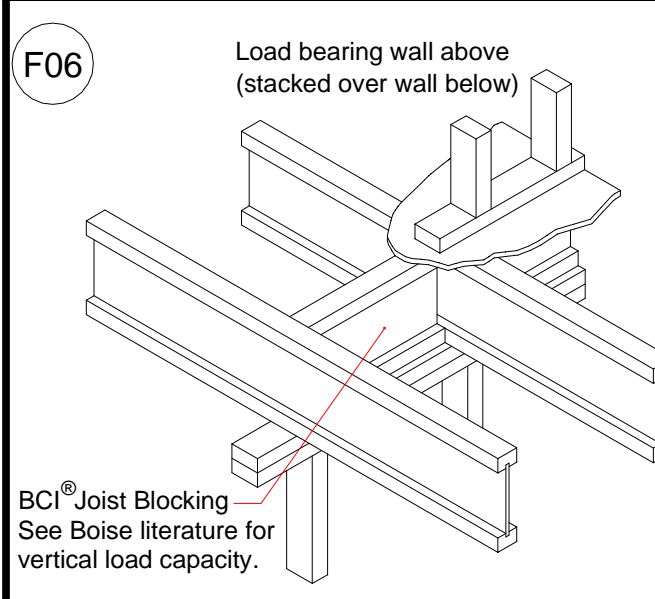
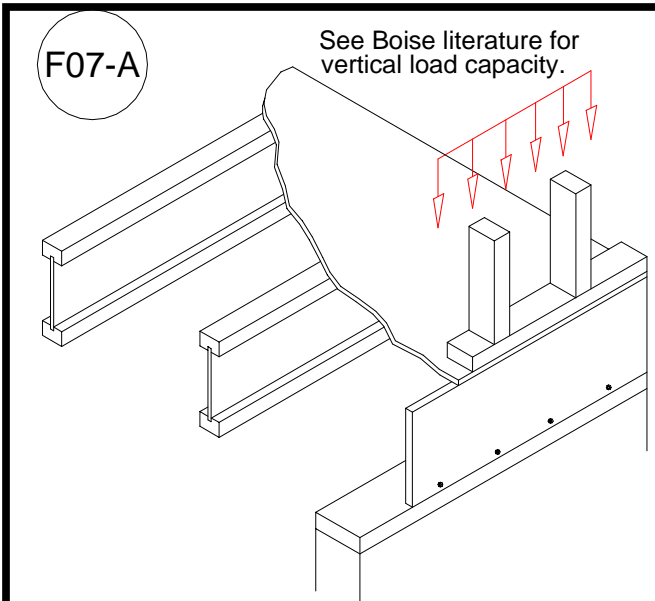

H & H HOMES
REDBUD - A-MASTER

2nd FLOOR EWP PLACEMENT PLAN
Builders FirstSource, Central Carolina Markets
DRAWN BY: CORY D DRIETZ DATE: 22/JAN/18
SCALE: NOT TO SCALE JOB NUMBER:

MINIMUM DESIGN DATA
LIVE LOAD 40 PSF
DEAD LOAD 10 PSF
TOTAL LOAD 50 PSF
DOL = 100%
DEFLECTION CRITERIA L/480 (MINIMUM)

ARCHITECTURAL PLAN DATE 5-31-16

SEAL DATE 1-9-17
Sheet 1 of 1

