

RE: 200607RT1
 FFH-WILSON PLAN 25 PLANTERS GLEN

Trenco
 818 Soundside Rd
 Edenton, NC 27932

Site Information:

Customer: Project Name: 200607RT1
 Lot/Block: Model:
 Address: Subdivision:
 City: State:

General Truss Engineering Criteria & Design Loads (Individual Truss Design Drawings Show Special Loading Conditions):

Design Code: IRC2015/TPI2014 Design Program: MiTek 20/20 8.3
 Wind Code: ASCE 7-10 Wind Speed: 120 mph
 Roof Load: 40.0 psf Floor Load: N/A psf

This package includes 23 individual, dated Truss Design Drawings and 0 Additional Drawings.

No.	Seal#	Truss Name	Date	No.	Seal#	Truss Name	Date
1	E14316805	a01	4/20/2020	21	E14316825	v02	4/20/2020
2	E14316806	a02	4/20/2020	22	E14316826	v03	4/20/2020
3	E14316807	a03	4/20/2020	23	E14316827	v04	4/20/2020
4	E14316808	a04	4/20/2020				
5	E14316809	a05	4/20/2020				
6	E14316810	a06	4/20/2020				
7	E14316811	a07	4/20/2020				
8	E14316812	a08	4/20/2020				
9	E14316813	a09	4/20/2020				
10	E14316814	b01	4/20/2020				
11	E14316815	b02	4/20/2020				
12	E14316816	c01	4/20/2020				
13	E14316817	c02	4/20/2020				
14	E14316818	c03	4/20/2020				
15	E14316819	d01	4/20/2020				
16	E14316820	d02	4/20/2020				
17	E14316821	e01	4/20/2020				
18	E14316822	e02	4/20/2020				
19	E14316823	e03	4/20/2020				
20	E14316824	v01	4/20/2020				

The truss drawing(s) referenced above have been prepared by
 Truss Engineering Co. under my direct supervision
 based on the parameters provided by Carolina Structural Systems, LLC.
 Truss Design Engineer's Name: Gilbert, Eric
 My license renewal date for the state of North Carolina is December 31, 2020.
 North Carolina COA: C-0844

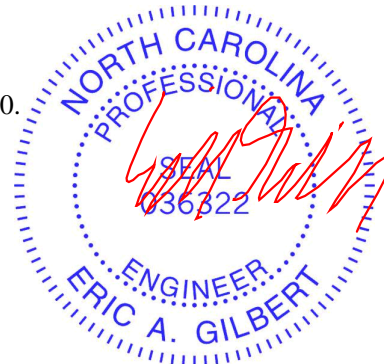

IMPORTANT NOTE: The seal on these truss component designs is a certification that the engineer named is licensed in the jurisdiction(s) identified and that the designs comply with ANSI/TPI 1. These designs are based upon parameters shown (e.g., loads, supports, dimensions, shapes and design codes), which were given to TRENCO. Any project specific information included is for TRENCO customers file reference purpose only, and was not taken into account in the preparation of these designs. TRENCO has not independently verified the applicability of the design parameters or the designs for any particular building. Before use, the building designer should verify applicability of design parameters and properly incorporate these designs into the overall building design per ANSI/TPI 1, Chapter 2.

RE: 200607RT1
 FFH-WILSON PLAN 25 PLANTERS GLEN

Trenco
 818 Soundside Rd
 Edenton, NC 27932

Site Information:

Customer: Project Name: 200607RT1
 Lot/Block: Model:
 Address: Subdivision:
 City: State:

General Truss Engineering Criteria & Design Loads (Individual Truss Design Drawings Show Special Loading Conditions):

Design Code: IRC2015/TPI2014 Design Program: MiTek 20/20 8.3
 Wind Code: ASCE 7-10 Wind Speed: 120 mph
 Roof Load: 40.0 psf Floor Load: N/A psf

This package includes 23 individual, dated Truss Design Drawings and 0 Additional Drawings.

No.	Seal#	Truss Name	Date	No.	Seal#	Truss Name	Date
1	E14316805	a01	4/20/2020	21	E14316825	v02	4/20/2020
2	E14316806	a02	4/20/2020	22	E14316826	v03	4/20/2020
3	E14316807	a03	4/20/2020	23	E14316827	v04	4/20/2020
4	E14316808	a04	4/20/2020				
5	E14316809	a05	4/20/2020				
6	E14316810	a06	4/20/2020				
7	E14316811	a07	4/20/2020				
8	E14316812	a08	4/20/2020				
9	E14316813	a09	4/20/2020				
10	E14316814	b01	4/20/2020				
11	E14316815	b02	4/20/2020				
12	E14316816	c01	4/20/2020				
13	E14316817	c02	4/20/2020				
14	E14316818	c03	4/20/2020				
15	E14316819	d01	4/20/2020				
16	E14316820	d02	4/20/2020				
17	E14316821	e01	4/20/2020				
18	E14316822	e02	4/20/2020				
19	E14316823	e03	4/20/2020				
20	E14316824	v01	4/20/2020				

The truss drawing(s) referenced above have been prepared by Truss Engineering Co. under my direct supervision based on the parameters provided by Carolina Structural Systems, LLC. Truss Design Engineer's Name: Gilbert, Eric My license renewal date for the state of South Carolina is June 30, 2020. South Carolina COA: C01451

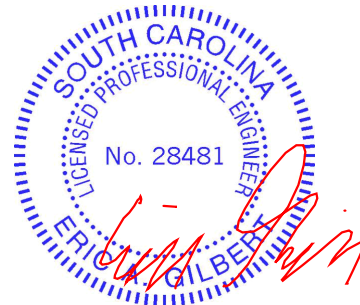

IMPORTANT NOTE: The seal on these truss component designs is a certification that the engineer named is licensed in the jurisdiction(s) identified and that the designs comply with ANSI/TPI 1. These designs are based upon parameters shown (e.g., loads, supports, dimensions, shapes and design codes), which were given to TRENCO. Any project specific information included is for TRENCO customers file reference purpose only, and was not taken into account in the preparation of these designs. TRENCO has not independently verified the applicability of the design parameters or the designs for any particular building. Before use, the building designer should verify applicability of design parameters and properly incorporate these designs into the overall building design per ANSI/TPI 1, Chapter 2.

Job 200607RT1	Truss A01	Truss Type Common	Qty 3	Ply 1	FFH-WILSON PLAN 25 PLANTERS GLEN	E14316805
------------------	--------------	----------------------	----------	----------	----------------------------------	-----------

Carolina Structural Systems, LLC, Ether, NC - 27247,

8.330 s Mar 23 2020 MiTek Industries, Inc. Mon Apr 20 14:37:59 2020 Page 1

ID:ng1sARatyWRgmLmP2hZLLXyQUhk-HptwawaoZB7mlVyvH8bUduyLi9f7SNE24XUSGzOoDc

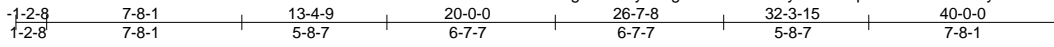

MTHNH18

Scale = 1:90.6

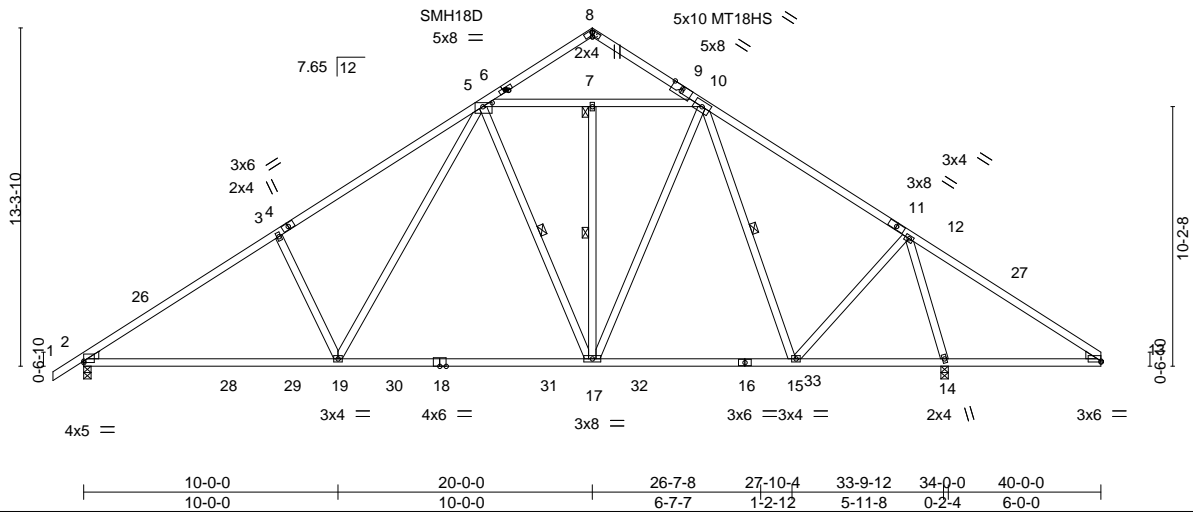

Plate Offsets (X,Y)-- [2:0-0-0,0-0-12], [5:0-4-7,0-1-14], [6:0-1-0,0-1-0], [8:0-1-2,0-1-12], [13:0-0-0,0-0-8]

LOADING (psf)	SPACING-	2-0-0	CSI.	DEFL.	in (loc)	l/defl	L/d	PLATES	GRIP
TCLL 20.0	Plate Grip DOL	1.00	TC 0.67	Vert(LL)	-0.31	17-19	>999	MT20	244/190
TCDL 10.0	Lumber DOL	1.15	BC 0.77	Vert(CT)	-0.49	17-19	>835	MT18HS	244/190
BCLL 0.0 *	Rep Stress Incr	YES	WB 0.85	Horz(CT)	0.05	14	n/a		
BCDL 10.0	Code IRC2015/TPI2014		Matrix-MS						
								Weight: 251 lb	FT = 20%

LUMBER-
TOP CHORD 2x4 SP No.1 *Except*
5-10,6-8,8-9: 2x4 SP No.2
BOT CHORD 2x4 SP No.1
WEBS 2x4 SP No.2
WEDGE
Left: 2x4 SP No.3 , Right: 2x4 SP No.3

BRACING-
TOP CHORD Structural wood sheathing directly applied or 3-6-14 oc purlins.
Rigid ceiling directly applied or 10-0-0 oc bracing, Except:
BOT CHORD 6-0-0 oc bracing: 13-14.
WEBS 1 Row at midpt 5-17, 7-17, 10-15
JOINTS 1 Brace at Jt(s): 7

REACTIONS. (size) 2=0-3-8, 14=0-3-8
Max Horz 2=237(LC 10)
Max Uplift 2=40(LC 11), 14=13(LC 11)
Max Grav 2=1469(LC 16), 14=1887(LC 1)

FORCES. (lb) - Max. Comp./Max. Ten. - All forces 250 (lb) or less except when shown.
TOP CHORD 2-3=-2118/94, 3-5=-1971/169, 5-8=-262/56, 8-10=-285/63, 10-12=-1034/124,
12-13=-176/512, 5-7=-979/131, 7-10=-980/132
BOT CHORD 2-19=0/1861, 17-19=0/1261, 15-17=0/962, 14-15=0/251, 13-14=-313/197
WEBS 3-19=-431/174, 5-19=-40/849, 5-17=-289/107, 10-17=0/589, 12-15=0/844,
12-14=-1767/225, 10-15=-474/75

- NOTES-**
- Unbalanced roof live loads have been considered for this design.
 - Wind: ASCE 7-10; Vult=120mph (3-second gust) Vasd=95mph; TCDL=6.0psf; BCDL=6.0psf; h=25ft; B=45ft; L=40ft; eave=5ft; Cat. II; Exp B; Enclosed; MWFRS (directional) and C-C Exterior(2) -1-2-8 to 2-9-8, Interior(1) 2-9-8 to 20-0-0, Exterior(2) 20-0-0 to 24-1-15, Interior(1) 24-1-15 to 40-0-0 zone; cantilever left and right exposed ; end vertical left and right exposed; C-C for members and forces & MWFRS for reactions shown; Lumber DOL=1.60 plate grip DOL=1.60
 - Provide adequate drainage to prevent water ponding.
 - All plates are MT20 plates unless otherwise indicated.
 - Attach MiTek MTHNH18 (Half and Half Plate) on each face of truss with USP NA11 nails (0.131" x 1.5") in pre-punched holes provided. All nail holes must be filled (6 Nails per side 12 nails total).
 - See HINGE PLATE DETAILS for plate placement.
 - Provisions must be made to prevent lateral movement of hinged member(s) during transportation.
 - * This truss has been designed for a live load of 20.0psf on the bottom chord in all areas where a rectangle 3-6-0 tall by 2-0-0 wide will fit between the bottom chord and any other members, with BCDL = 10.0psf.
 - Provide mechanical connection (by others) of truss to bearing plate capable of withstanding 100 lb uplift at joint(s) 2, 14.
 - Graphical purlin representation does not depict the size or the orientation of the purlin along the top and/or bottom chord.



April 20,2020

WARNING - Verify design parameters and READ NOTES ON THIS AND INCLUDED MITEK REFERENCE PAGE MII-7473 rev. 10/03/2015 BEFORE USE.

Design valid for use only with MiTek® connectors. This design is based only upon parameters shown, and is for an individual building component, not a truss system. Before use, the building designer must verify the applicability of design parameters and properly incorporate this design into the overall building design. Bracing indicated is to prevent buckling of individual truss web and/or chord members only. Additional temporary and permanent bracing is always required for stability and to prevent collapse with possible personal injury and property damage. For general guidance regarding the fabrication, storage, delivery, erection and bracing of trusses and truss systems, see **ANSI/TPI1 Quality Criteria, DSB-89 and BCSI Building Component Safety Information** available from Truss Plate Institute, 218 N. Lee Street, Suite 312, Alexandria, VA 22314.



818 Soundside Road
Edenton, NC 27932

Job 200607RT1	Truss A02	Truss Type GABLE	Qty 1	Ply 1	FFH-WILSON PLAN 25 PLANTERS GLEN	E14316806
------------------	--------------	---------------------	----------	----------	----------------------------------	-----------

Carolina Structural Systems, LLC, Ether, NC - 27247,

8.330 s Mar 23 2020 MiTek Industries, Inc. Mon Apr 20 14:38:00 2020 Page 1

ID:ng1sARatyWRgmLmP2hZLLXyQUhk-m?RlnGbQKVF90v48T?fq1rQ756VusvdNHkH1?jzOoDb

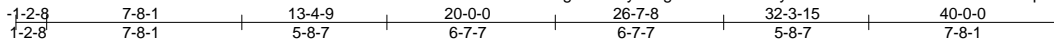

MTHNH18

Scale = 1:90.6

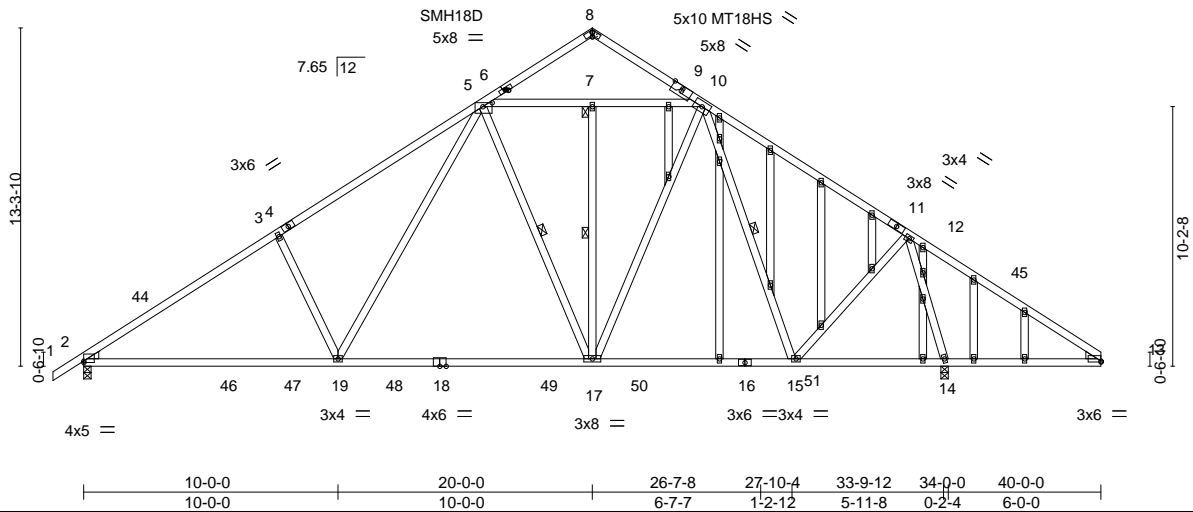

Plate Offsets (X,Y)--	[2:0-0-0,0-0-12], [5:0-4-7,0-1-14], [6:0-1-0,0-1-0], [8:0-1-2,0-1-12], [13:0-0-0,0-0-8]
-----------------------	---

LOADING (psf)	SPACING-	2-0-0	CSL	DEFL.	in (loc)	l/defl	L/d	PLATES	GRIP
TCLL 20.0	Plate Grip DOL	1.00	TC 0.67	Vert(LL)	-0.31 17-19	>999	240	MT20	244/190
TCDL 10.0	Lumber DOL	1.15	BC 0.77	Vert(CT)	-0.49 17-19	>835	180	MT18HS	244/190
BCLL 0.0 *	Rep Stress Incr	YES	WB 0.85	Horz(CT)	0.05 14	n/a	n/a		
BCDL 10.0	Code	IRC2015/TPI2014	Matrix-MS						
								Weight: 305 lb	FT = 20%

LUMBER-
TOP CHORD 2x4 SP No.1 *Except*
5-10,6-8,8-9: 2x4 SP No.2
BOT CHORD 2x4 SP No.1
WEBS 2x4 SP No.2
OTHERS 2x4 SP No.2
WEDGE
Left: 2x4 SP No.3 , Right: 2x4 SP No.3

BRACING-
TOP CHORD Structural wood sheathing directly applied or 3-6-14 oc purlins.
BOT CHORD Rigid ceiling directly applied or 10-0-0 oc bracing, Except:
6-0-0 oc bracing: 13-14.
WEBS 1 Row at midpt 5-17, 7-17, 10-15
JOINTS 1 Brace at Jt(s): 7

REACTIONS. (size) 2=0-3-8, 14=0-3-8
Max Horz 2=237(LC 10)
Max Uplift 2=40(LC 11), 14=13(LC 11)
Max Grav 2=1469(LC 16), 14=1887(LC 1)

FORCES. (lb) - Max. Comp./Max. Ten. - All forces 250 (lb) or less except when shown.
TOP CHORD 2-3=-2118/94, 3-5=-1971/169, 5-8=-262/56, 8-10=-285/63, 10-12=-1034/124,
12-13=-176/512, 5-7=-979/131, 7-10=-980/132
BOT CHORD 2-19=0/1861, 17-19=0/1261, 15-17=0/962, 14-15=0/251, 13-14=-313/197
WEBS 3-19=-431/174, 5-19=-40/849, 5-17=-289/107, 10-17=0/589, 12-15=0/844,
12-14=-1767/225, 10-15=-474/75

- NOTES-**
- Unbalanced roof live loads have been considered for this design.
 - Wind: ASCE 7-10; Vult=120mph (3-second gust) Vasd=95mph; TCDL=6.0psf; BCDL=6.0psf; h=25ft; B=45ft; L=40ft; eave=5ft; Cat. II; Exp B; Enclosed; MWFRS (directional) and C-C Exterior(2) -1-2-8 to 2-9-8, Interior(1) 2-9-8 to 20-0-0, Exterior(2) 20-0-0 to 24-1-15, Interior(1) 24-1-15 to 40-0-0 zone; cantilever left and right exposed; end vertical left and right exposed; C-C for members and forces & MWFRS for reactions shown; Lumber DOL=1.60 plate grip DOL=1.60
 - Truss designed for wind loads in the plane of the truss only. For studs exposed to wind (normal to the face), see Standard Industry Gable End Details as applicable, or consult qualified building designer as per ANSI/TPI 1.
 - Provide adequate drainage to prevent water ponding.
 - All plates are MT20 plates unless otherwise indicated.
 - All plates are 2x4 MT20 unless otherwise indicated.
 - Attach MiTek MTHNH18 (Half and Half Plate) on each face of truss with USP NA11 nails (0.131" x 1.5") in pre-punched holes provided. All nail holes must be filled (6 Nails per side 12 nails total).
 - See HINGE PLATE DETAILS for plate placement.
 - Provisions must be made to prevent lateral movement of hinged member(s) during transportation.
 - Gable studs spaced at 2-0-0 oc.
 - * This truss has been designed for a live load of 20.0psf on the bottom chord in all areas where a rectangle 3-6-0 tall by 2-0-0 wide will fit between the bottom chord and any other members, with BCDL = 10.0psf.
 - Provide mechanical connection (by others) of truss to bearing plate capable of withstanding 100 lb uplift at joint(s) 2, 14.
 - Graphical purlin representation does not depict the size or the orientation of the purlin along the top and/or bottom chord.



April 20,2020

WARNING - Verify design parameters and READ NOTES ON THIS AND INCLUDED MITEK REFERENCE PAGE MII-7473 rev. 10/03/2015 BEFORE USE.
Design valid for use only with MiTek® connectors. This design is based only upon parameters shown, and is for an individual building component, not a truss system. Before use, the building designer must verify the applicability of design parameters and properly incorporate this design into the overall building design. Bracing indicated is to prevent buckling of individual truss web and/or chord members only. Additional temporary and permanent bracing is always required for stability and to prevent collapse with possible personal injury and property damage. For general guidance regarding the fabrication, storage, delivery, erection and bracing of trusses and truss systems, see **ANSI/TPI1 Quality Criteria, DSB-89 and BCSI Building Component Safety Information** available from Truss Plate Institute, 218 N. Lee Street, Suite 312, Alexandria, VA 22314.



818 Soundside Road
Edenton, NC 27932

Job 200607RT1	Truss A03	Truss Type COMMON	Qty 2	Ply 1	FFH-WILSON PLAN 25 PLANTERS GLEN	E14316807
------------------	--------------	----------------------	----------	----------	----------------------------------	-----------

Carolina Structural Systems, LLC, Ether, NC - 27247,

8.330 s Mar 23 2020 MiTek Industries, Inc. Mon Apr 20 14:38:01 2020 Page 1

ID:ng1sARatyWRgmLmP2hZLLXyQUhk-EC?g?cb25oN003fl1A3Z2zEBWr2bMuXWO0bX9zOoDa

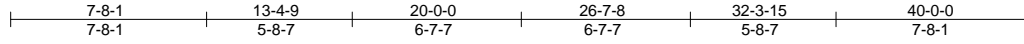

MTHNH18

Scale = 1:90.2

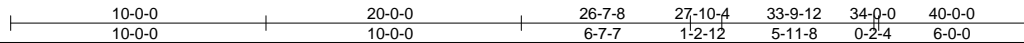
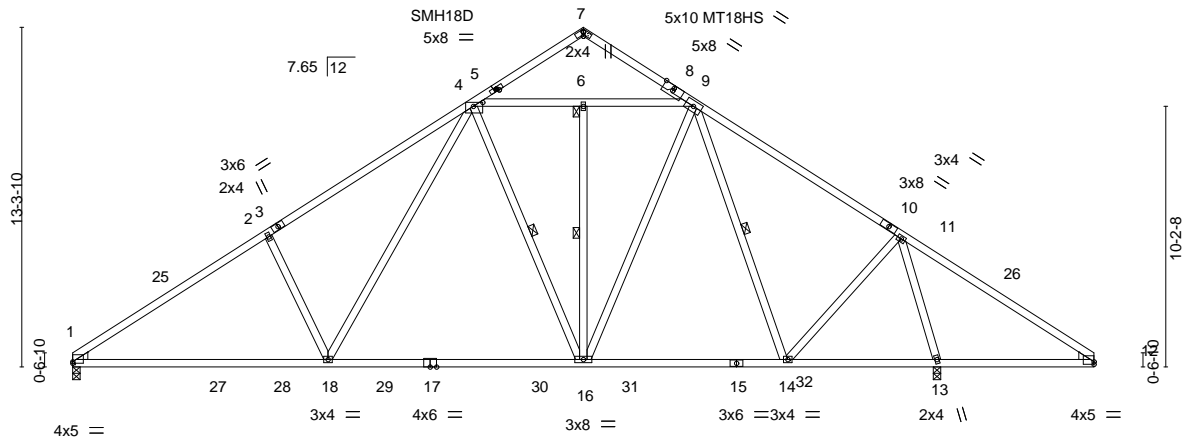

Plate Offsets (X,Y)-- [1:0-0-0,0-0-12], [4:0-4-7,0-1-14], [5:0-1-0,0-1-0], [7:0-1-2,0-1-12], [12:0-0-0,0-1-4]

LOADING (psf)	SPACING-	2-0-0	CSI.	DEFL.	in (loc)	l/defl	L/d	PLATES	GRIP
TCLL 20.0	Plate Grip DOL	1.00	TC 0.90	Vert(LL)	-0.31	16-18	>999	MT20	244/190
TCDL 10.0	Lumber DOL	1.15	BC 0.77	Vert(CT)	-0.49	16-18	>835	MT18HS	244/190
BCLL 0.0 *	Rep Stress Incr	YES	WB 0.85	Horz(CT)	0.05	13	n/a		
BCDL 10.0	Code IRC2015/TPI2014		Matrix-MS						
								Weight: 249 lb	FT = 20%

LUMBER-

TOP CHORD 2x4 SP No.2 *Except*
3-5,8-10: 2x4 SP No.1
BOT CHORD 2x4 SP No.1
WEBS 2x4 SP No.2
WEDGE
Left: 2x4 SP No.3 , Right: 2x4 SP No.3

BRACING-

TOP CHORD Structural wood sheathing directly applied or 2-2-0 oc purlins.
BOT CHORD Rigid ceiling directly applied or 10-0-0 oc bracing, Except:
6-0-0 oc bracing: 12-13.
WEBS 1 Row at midpt 4-16, 6-16, 9-14
JOINTS 1 Brace at Jt(s): 6

REACTIONS.

(size) 1=0-3-8, 13=0-3-8
Max Horz 1=-227(LC 9)
Max Uplift 1=-9(LC 11), 13=-14(LC 11)
Max Grav 1=1403(LC 16), 13=1888(LC 1)

FORCES. (lb) - Max. Comp./Max. Ten. - All forces 250 (lb) or less except when shown.

TOP CHORD 1-2=-2123/103, 2-4=-1977/179, 4-7=-262/56, 7-9=-285/63, 9-11=-1034/124,
11-12=-180/511, 4-6=-981/134, 6-9=-981/134
BOT CHORD 1-18=0/1866, 16-18=0/1263, 14-16=0/964, 13-14=0/250, 12-13=-313/196
WEBS 2-18=-433/180, 4-18=-50/854, 4-16=-291/108, 9-16=0/589, 11-14=0/845,
11-13=-1764/223, 9-14=-476/75

NOTES-

- Unbalanced roof live loads have been considered for this design.
- Wind: ASCE 7-10; Vult=120mph (3-second gust) Vasd=95mph; TCDL=6.0psf; BCDL=6.0psf; h=25ft; B=45ft; L=40ft; eave=5ft; Cat. II; Exp B; Enclosed; MWFRS (directional) and C-C Exterior(2) 0-0-0 to 4-0-0, Interior(1) 4-0-0 to 20-0-0, Exterior(2) 20-0-0 to 24-1-15 , Interior(1) 24-1-15 to 40-0-0 zone; cantilever left and right exposed ; end vertical left and right exposed; C-C for members and forces & MWFRS for reactions shown; Lumber DOL=1.60 plate grip DOL=1.60
- Provide adequate drainage to prevent water ponding.
- All plates are MT20 plates unless otherwise indicated.
- Attach MiTek MTHNH18 (Half and Half Plate) on each face of truss with USP NA11 nails (0.131" x 1.5") in pre-punched holes provided. All nail holes must be filled (6 Nails per side 12 nails total).
- See HINGE PLATE DETAILS for plate placement.
- Provisions must be made to prevent lateral movement of hinged member(s) during transportation.
- * This truss has been designed for a live load of 20.0psf on the bottom chord in all areas where a rectangle 3-6-0 tall by 2-0-0 wide will fit between the bottom chord and any other members, with BCDL = 10.0psf.
- Provide mechanical connection (by others) of truss to bearing plate capable of withstanding 100 lb uplift at joint(s) 1, 13.
- Graphical purlin representation does not depict the size or the orientation of the purlin along the top and/or bottom chord.



April 20,2020

WARNING - Verify design parameters and READ NOTES ON THIS AND INCLUDED MITEK REFERENCE PAGE MII-7473 rev. 10/03/2015 BEFORE USE.

Design valid for use only with MiTek® connectors. This design is based only upon parameters shown, and is for an individual building component, not a truss system. Before use, the building designer must verify the applicability of design parameters and properly incorporate this design into the overall building design. Bracing indicated is to prevent buckling of individual truss web and/or chord members only. Additional temporary and permanent bracing is always required for stability and to prevent collapse with possible personal injury and property damage. For general guidance regarding the fabrication, storage, delivery, erection and bracing of trusses and truss systems, see ANS/TP1 Quality Criteria, DSB-89 and BCSI Building Component Safety Information available from Truss Plate Institute, 218 N. Lee Street, Suite 312, Alexandria, VA 22314.



818 Soundside Road
Edenton, NC 27932

Job 200607RT1	Truss A04	Truss Type COMMON	Qty 2	Ply 1	FFH-WILSON PLAN 25 PLANTERS GLEN	E14316808
------------------	--------------	----------------------	----------	----------	----------------------------------	-----------

Carolina Structural Systems, LLC, Ether, NC - 27247,

8.330 s Mar 23 2020 MiTek Industries, Inc. Mon Apr 20 14:38:03 2020 Page 1

ID:ng1sARatyWRgmLmP2hZLLXyQUhk-Aa6QQldldQekFMpj87CXFT2cxJWA3FipziVhb2zOoDY

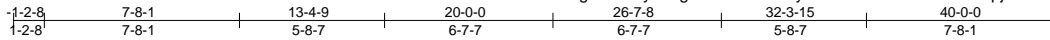

MTHNH18

Scale = 1:90.6

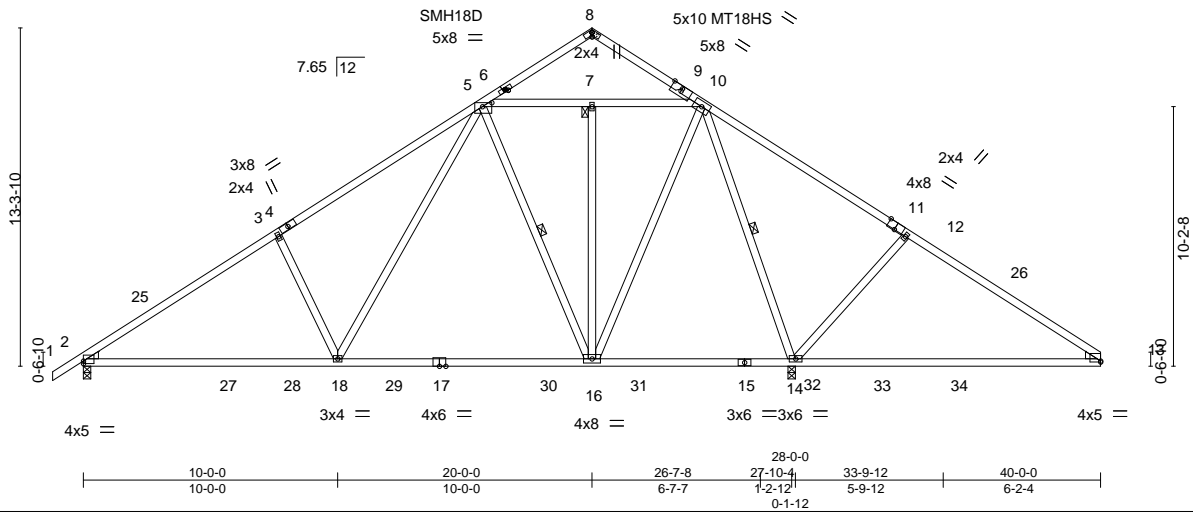

Plate Offsets (X,Y)-- [2:0-0-0,0-1-4], [5:0-4-7,0-1-14], [6:0-1-0,0-1-0], [8:0-1-2,0-1-12], [11:0-4-0,Edge], [13:0-0-0,0-0-8]

LOADING (psf)	SPACING-	2-0-0	CSL	DEFL.	in (loc)	l/defl	L/d	PLATES	GRIP
TCLL 20.0	Plate Grip DOL	1.00	TC 0.82	Vert(LL)	-0.35 16-18	>951	240	MT20	244/190
TCDL 10.0	Lumber DOL	1.15	BC 0.80	Vert(CT)	-0.89 14-21	>163	120	MT18HS	244/190
BCLL 0.0 *	Rep Stress Incr	YES	WB 0.95	Horz(CT)	0.03 14	n/a	n/a		
BCDL 10.0	Code IRC2015/TPI2014		Matrix-MS	Wind(LL)	0.63 14-21	>229	120		
								Weight: 244 lb	FT = 20%

LUMBER-
TOP CHORD 2x4 SP No.1 *Except*
5-10,6-8,8-9: 2x4 SP No.2
BOT CHORD 2x4 SP No.1 *Except*
15-17: 2x4 SP No.2
WEBS 2x4 SP No.2
WEDGE
Left: 2x4 SP No.3 , Right: 2x4 SP No.3

BRACING-
TOP CHORD Structural wood sheathing directly applied or 4-9-13 oc purlins.
BOT CHORD Rigid ceiling directly applied or 6-0-0 oc bracing.
WEBS 1 Row at midpt 5-16, 10-14
JOINTS 1 Brace at Jt(s): 7

REACTIONS. (size) 2=0-3-8, 14=0-3-8
Max Horz 2=237(LC 10)
Max Uplift 2=38(LC 11), 14=16(LC 11)
Max Grav 2=1064(LC 16), 14=2367(LC 18)

FORCES. (lb) - Max. Comp./Max. Ten. - All forces 250 (lb) or less except when shown.
TOP CHORD 2-3=-1410/61, 3-5=-1257/134, 5-8=-264/58, 8-10=-285/64, 10-12=-255/979,
12-13=-262/634, 5-7=-266/128, 7-10=-266/128
BOT CHORD 2-18=0/1262, 16-18=0/636, 14-16=-217/311, 13-14=-399/257
WEBS 3-18=-441/176, 5-18=-53/891, 5-16=-685/203, 10-16=-15/956, 12-14=-487/224,
10-14=-1790/277

- NOTES-**
- Unbalanced roof live loads have been considered for this design.
 - Wind: ASCE 7-10; Vult=120mph (3-second gust) Vasd=95mph; TCDL=6.0psf; h=25ft; B=45ft; L=40ft; eave=5ft; Cat. II; Exp B; Enclosed; MWFRS (directional) and C-C Exterior(2) -1-2-8 to 2-9-8, Interior(1) 2-9-8 to 20-0-0, Exterior(2) 20-0-0 to 24-1-15, Interior(1) 24-1-15 to 40-0-0 zone; cantilever left and right exposed; end vertical left and right exposed; C-C for members and forces & MWFRS for reactions shown; Lumber DOL=1.60 plate grip DOL=1.60
 - Provide adequate drainage to prevent water ponding.
 - All plates are MT20 plates unless otherwise indicated.
 - Attach MiTek MTHNH18 (Half and Half Plate) on each face of truss with USP NA11 nails (0.131" x 1.5") in pre-punched holes provided. All nail holes must be filled (6 Nails per side 12 nails total).
 - See HINGE PLATE DETAILS for plate placement.
 - Provisions must be made to prevent lateral movement of hinged member(s) during transportation.
 - * This truss has been designed for a live load of 20.0psf on the bottom chord in all areas where a rectangle 3-6-0 tall by 2-0-0 wide will fit between the bottom chord and any other members, with BCDL = 10.0psf.
 - Provide mechanical connection (by others) of truss to bearing plate capable of withstanding 100 lb uplift at joint(s) 2, 14.
 - Graphical purlin representation does not depict the size or the orientation of the purlin along the top and/or bottom chord.



April 20,2020

WARNING - Verify design parameters and READ NOTES ON THIS AND INCLUDED MITEK REFERENCE PAGE MII-7473 rev. 10/03/2015 BEFORE USE.

Design valid for use only with MiTek® connectors. This design is based only upon parameters shown, and is for an individual building component, not a truss system. Before use, the building designer must verify the applicability of design parameters and properly incorporate this design into the overall building design. Bracing indicated is to prevent buckling of individual truss web and/or chord members only. Additional temporary and permanent bracing is always required for stability and to prevent collapse with possible personal injury and property damage. For general guidance regarding the fabrication, storage, delivery, erection and bracing of trusses and truss systems, see **ANSI/TPI1 Quality Criteria, DSB-89 and BCSI Building Component Safety Information** available from Truss Plate Institute, 218 N. Lee Street, Suite 312, Alexandria, VA 22314.



818 Soundside Road
Edenton, NC 27932

Job 200607RT1	Truss A05	Truss Type COMMON	Qty 1	Ply 1	FFH-WILSON PLAN 25 PLANTERS GLEN	E14316809
------------------	--------------	----------------------	----------	----------	----------------------------------	-----------

Carolina Structural Systems, LLC, Ether, NC - 27247,

8.330 s Mar 23 2020 MiTek Industries, Inc. Mon Apr 20 14:38:04 2020 Page 1

ID:ng1sARatyWRgmLmP2hZLLXyQUhk-engpdeewOjmbtWNwiqjmBhbnhjsRoi_zCMFF8UzOoDX

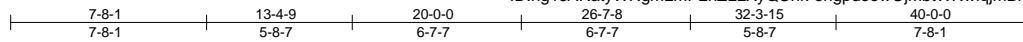

MTHNH18

Scale = 1:90.2

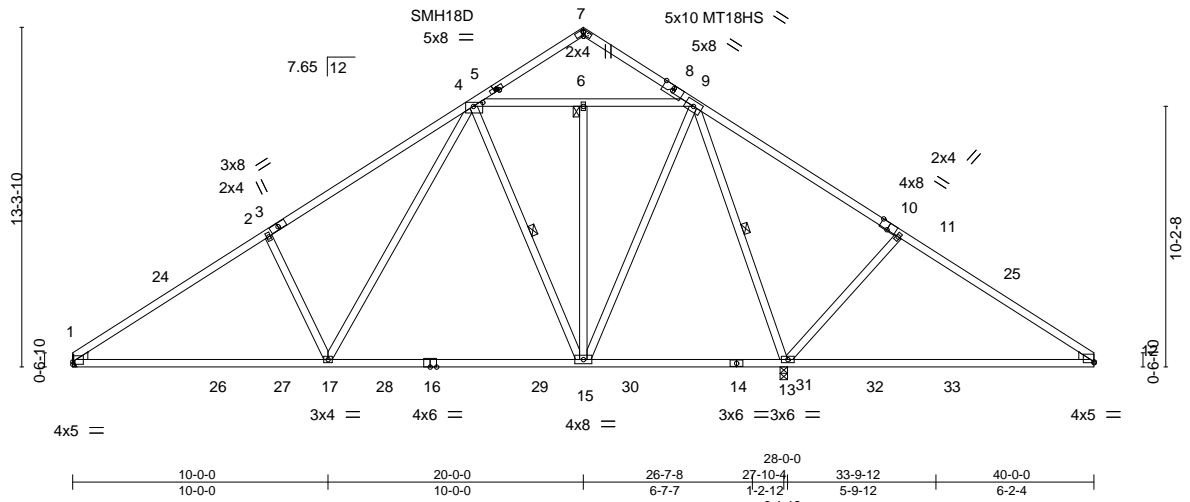

Plate Offsets (X,Y)-- [1:0-0-0,0-1-4], [4:0-4-7,0-1-14], [5:0-1-0,0-1-0], [7:0-1-2,0-1-12], [10:0-4-0,Edge], [12:0-0-0,0-0-8]

LOADING (psf)	SPACING-	2-0-0	CSI.	DEFL.	in (loc)	l/defl	L/d	PLATES	GRIP
TCLL 20.0	Plate Grip DOL	1.00	TC 0.82	Vert(LL)	-0.35	15-17	>951	MT20	244/190
TCDL 10.0	Lumber DOL	1.15	BC 0.79	Vert(CT)	-0.89	13-20	>163	MT18HS	244/190
BCLL 0.0 *	Rep Stress Incr	YES	WB 0.95	Horz(CT)	0.03	13	n/a		
BCDL 10.0	Code IRC2015/TPI2014		Matrix-MS	Wind(LL)	0.63	13-20	>229		
								Weight: 241 lb	FT = 20%

LUMBER-

TOP CHORD 2x4 SP No.1 *Except*
4-9,5-7,7-8: 2x4 SP No.2
BOT CHORD 2x4 SP No.1 *Except*
14-16: 2x4 SP No.2
WEBS 2x4 SP No.2
WEDGE
Left: 2x4 SP No.3 , Right: 2x4 SP No.3

BRACING-

TOP CHORD Structural wood sheathing directly applied or 4-9-10 oc purlins.
BOT CHORD Rigid ceiling directly applied or 6-0-0 oc bracing.
WEBS 1 Row at midpt 4-15, 9-13
JOINTS 1 Brace at Jt(s): 6

REACTIONS.

(size) 1=Mechanical, 13=0-3-8
Max Horz 1=-227(LC 9)
Max Uplift 1=-7(LC 11), 13=-16(LC 11)
Max Grav 1=997(LC 16), 13=2368(LC 18)

FORCES. (lb) - Max. Comp./Max. Ten. - All forces 250 (lb) or less except when shown.

TOP CHORD 1-2=-1415/64, 2-4=-1264/138, 4-7=-264/58, 7-9=-285/64, 9-11=-255/979,
11-12=-262/634, 4-6=-267/129, 6-9=-267/129
BOT CHORD 1-17=0/1269, 15-17=0/638, 13-15=-217/311, 12-13=-399/257
WEBS 2-17=-446/183, 4-17=-64/899, 4-15=-686/204, 9-15=-15/958, 11-13=-487/224,
9-13=-1792/277

NOTES-

- Unbalanced roof live loads have been considered for this design.
- Wind: ASCE 7-10; Vult=120mph (3-second gust) Vasd=95mph; TCCL=6.0psf; BCDL=6.0psf; h=25ft; B=45ft; L=40ft; eave=5ft; Cat. II; Exp B; Enclosed; MWFRS (directional) and C-C Exterior(2) 0-0-0 to 4-0-0, Interior(1) 4-0-0 to 20-0-0, Exterior(2) 20-0-0 to 24-1-15, Interior(1) 24-1-15 to 40-0-0 zone; cantilever left and right exposed; end vertical left and right exposed; C-C for members and forces & MWFRS for reactions shown; Lumber DOL=1.60 plate grip DOL=1.60
- Provide adequate drainage to prevent water ponding.
- All plates are MT20 plates unless otherwise indicated.
- Attach MiTek MTHNH18 (Half and Half Plate) on each face of truss with USP NA11 nails (0.131" x 1.5") in pre-punched holes provided. All nail holes must be filled (6 Nails per side 12 nails total).
- See HINGE PLATE DETAILS for plate placement.
- Provisions must be made to prevent lateral movement of hinged member(s) during transportation.
- * This truss has been designed for a live load of 20.0psf on the bottom chord in all areas where a rectangle 3-6-0 tall by 2-0-0 wide will fit between the bottom chord and any other members, with BCDL = 10.0psf.
- Refer to girder(s) for truss to truss connections.
- Provide mechanical connection (by others) of truss to bearing plate capable of withstanding 100 lb uplift at joint(s) 1, 13.
- Graphical purlin representation does not depict the size or the orientation of the purlin along the top and/or bottom chord.

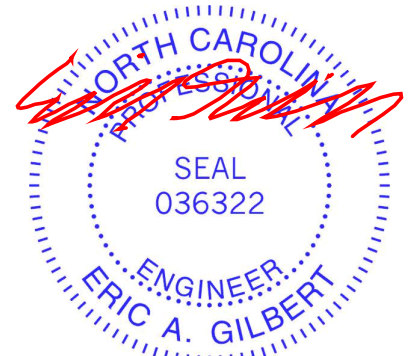

April 20,2020

WARNING - Verify design parameters and READ NOTES ON THIS AND INCLUDED MITEK REFERENCE PAGE MII-7473 rev. 10/03/2015 BEFORE USE.

Design valid for use only with MiTek® connectors. This design is based only upon parameters shown, and is for an individual building component, not a truss system. Before use, the building designer must verify the applicability of design parameters and properly incorporate this design into the overall building design. Bracing indicated is to prevent buckling of individual truss web and/or chord members only. Additional temporary and permanent bracing is always required for stability and to prevent collapse with possible personal injury and property damage. For general guidance regarding the fabrication, storage, delivery, erection and bracing of trusses and truss systems, see **ANSI/TPI1 Quality Criteria, DSB-89 and BCSI Building Component Safety Information** available from Truss Plate Institute, 218 N. Lee Street, Suite 312, Alexandria, VA 22314.



818 Soundside Road
Edenton, NC 27932

Job 200607RT1	Truss A06	Truss Type COMMON	Qty 5	Ply 1	FFH-WILSON PLAN 25 PLANTERS GLEN Job Reference (optional)	E14316810
------------------	--------------	----------------------	----------	----------	--	-----------

Carolina Structural Systems, LLC, Ether, NC - 27247,

8.330 s Mar 23 2020 MiTek Industries, Inc. Mon Apr 20 14:38:04 2020 Page 1

ID:ng1sARatyWRgmlmP2hZLLXyQUhk-engpdeewOjmbtWNwqjmBhbnejmoozhCMFF8UzOoDX

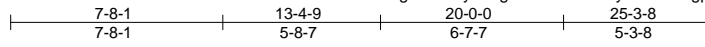

MTHNH18

Scale = 1:83.3

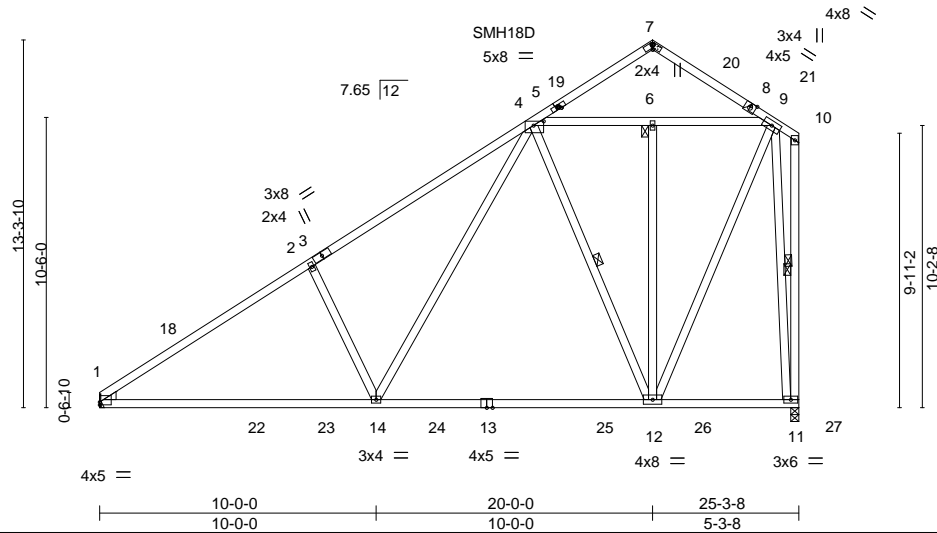

Plate Offsets (X,Y)-- [1:0-0-0,0-1-4], [4:0-4-7,0-1-14], [5:0-1-0,0-1-0], [7:0-1-2,0-1-12]

LOADING (psf)	SPACING-	2-0-0	CSI.	DEFL.	in (loc)	l/defl	L/d	PLATES	GRIP
TCLL 20.0	Plate Grip DOL	1.00	TC 0.82	Vert(LL)	-0.36	12-14	>847	240	244/190
TCDL 10.0	Lumber DOL	1.15	BC 0.84	Vert(CT)	-0.53	12-14	>568	180	244/190
BCLL 0.0 *	Rep Stress Incr	YES	WB 0.52	Horz(CT)	0.03	11	n/a	n/a	
BCDL 10.0	Code	IRC2015/TPI2014	Matrix-MS						
								Weight: 196 lb	FT = 20%

LUMBER-
TOP CHORD 2x4 SP No.2 *Except*
3-5: 2x4 SP No.1
BOT CHORD 2x4 SP No.1 *Except*
11-13: 2x4 SP No.2
WEBS 2x4 SP No.2
WEDGE
Left: 2x4 SP No.3

BRACING-
TOP CHORD Structural wood sheathing directly applied or 4-1-5 oc purlins, except end verticals.
BOT CHORD Rigid ceiling directly applied or 10-0-0 oc bracing.
WEBS 1 Row at midpt 4-12, 10-11, 9-11
JOINTS 1 Brace at Jt(s): 6

REACTIONS. (size) 1=Mechanical, 11=0-3-8
Max Horz 1=343(LC 10)
Max Uplift 11=17(LC 11)
Max Grav 1=1050(LC 16), 11=1151(LC 16)

FORCES. (lb) - Max. Comp./Max. Ten. - All forces 250 (lb) or less except when shown.
TOP CHORD 1-2=-1503/109, 2-4=-1358/185, 4-7=-292/64, 7-9=-295/68, 4-6=-346/139, 6-9=-348/139
BOT CHORD 1-14=-278/1328, 12-14=-182/708
WEBS 2-14=-441/177, 4-14=-45/884, 4-12=-620/184, 9-12=-38/928, 9-11=-1117/273

- NOTES-**
- Unbalanced roof live loads have been considered for this design.
 - Wind: ASCE 7-10; Vult=120mph (3-second gust) Vasd=95mph; TCCL=6.0psf; BCDL=6.0psf; h=25ft; B=45ft; L=25ft; eave=4ft; Cat. II; Exp B; Enclosed; MWFRS (directional) and C-C Exterior(2) 0-0-0 to 3-0-0, Interior(1) 3-0-0 to 20-0-0, Exterior(2) 20-0-0 to 23-0-0, Interior(1) 23-0-0 to 25-1-12 zone; cantilever left and right exposed ; end vertical left and right exposed;C-C for members and forces & MWFRS for reactions shown; Lumber DOL=1.60 plate grip DOL=1.60
 - Provide adequate drainage to prevent water ponding.
 - All plates are MT20 plates unless otherwise indicated.
 - Attach MiTek MTHNH18 (Half and Half Plate) on each face of truss with USP NA11 nails (0.131" x 1.5") in pre-punched holes provided. All nail holes must be filled (6 Nails per side 12 nails total).
 - See HINGE PLATE DETAILS for plate placement.
 - Provisions must be made to prevent lateral movement of hinged member(s) during transportation.
 - * This truss has been designed for a live load of 20.0psf on the bottom chord in all areas where a rectangle 3-6-0 tall by 2-0-0 wide will fit between the bottom chord and any other members, with BCDL = 10.0psf.
 - Refer to girder(s) for truss to truss connections.
 - Provide mechanical connection (by others) of truss to bearing plate capable of withstanding 100 lb uplift at joint(s) 11.
 - Graphical purlin representation does not depict the size or the orientation of the purlin along the top and/or bottom chord.



April 20,2020

WARNING - Verify design parameters and READ NOTES ON THIS AND INCLUDED MITEK REFERENCE PAGE MII-7473 rev. 10/03/2015 BEFORE USE.

Design valid for use only with MiTek® connectors. This design is based only upon parameters shown, and is for an individual building component, not a truss system. Before use, the building designer must verify the applicability of design parameters and properly incorporate this design into the overall building design. Bracing indicated is to prevent buckling of individual truss web and/or chord members only. Additional temporary and permanent bracing is always required for stability and to prevent collapse with possible personal injury and property damage. For general guidance regarding the fabrication, storage, delivery, erection and bracing of trusses and truss systems, see **ANSI/TPI1 Quality Criteria, DSB-89 and BCSI Building Component Safety Information** available from Truss Plate Institute, 218 N. Lee Street, Suite 312, Alexandria, VA 22314.



818 Soundside Road
Edenton, NC 27932

Job 200607RT1	Truss A07	Truss Type COMMON	Qty 3	Ply 1	FFH-WILSON PLAN 25 PLANTERS GLEN	E14316811
------------------	--------------	----------------------	----------	----------	----------------------------------	-----------

Carolina Structural Systems, LLC, Ether, NC - 27247,

8.330 s Mar 23 2020 MiTek Industries, Inc. Mon Apr 20 14:38:05 2020 Page 1

ID:ng1sARatyWRgmLmP2hZLLXyQUhk-6zEBrZeZ81uSUgy6GYE?ku8xX7ByXFx6R?_ogwzOoDW

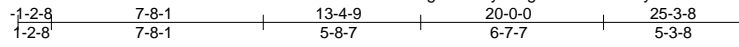

MTHNH18

Scale = 1:83.5

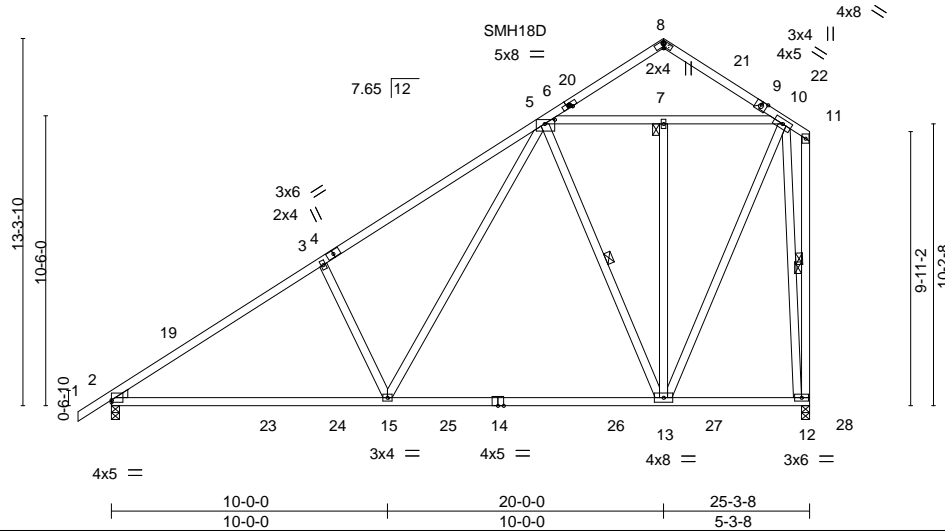

Plate Offsets (X,Y)-- [2:0-0-0,0-1-0], [5:0-4-7,0-1-14], [6:0-1-0,0-1-0], [8:0-1-2,0-1-12]

LOADING (psf)	SPACING-	2-0-0	CSI.	DEFL.	in (loc)	l/defl	L/d	PLATES	GRIP
TCLL 20.0	Plate Grip DOL	1.00	TC 0.81	Vert(LL)	-0.36	13-15	>847	MT20	244/190
TCDL 10.0	Lumber DOL	1.15	BC 0.84	Vert(CT)	-0.53	13-15	>566	MT18HS	244/190
BCLL 0.0 *	Rep Stress Incr	YES	WB 0.52	Horz(CT)	0.03	12	n/a		
BCDL 10.0	Code	IRC2015/TPI2014	Matrix-MS						
								Weight: 199 lb	FT = 20%

LUMBER-
TOP CHORD 2x4 SP No.2 *Except*
4-6: 2x4 SP No.1
BOT CHORD 2x4 SP No.1 *Except*
12-14: 2x4 SP No.2
WEBS 2x4 SP No.2
WEDGE
Left: 2x4 SP No.3

BRACING-
TOP CHORD Structural wood sheathing directly applied or 4-4-1 oc purlins, except end verticals.
BOT CHORD Rigid ceiling directly applied or 10-0-0 oc bracing.
WEBS 1 Row at midpt 5-13, 11-12, 10-12
JOINTS 1 Brace at Jt(s): 7

REACTIONS. (size) 2=0-3-8, 12=0-3-8
Max Horz 2=352(LC 10)
Max Uplift 2=-29(LC 11), 12=-16(LC 11)
Max Grav 2=1116(LC 16), 12=1150(LC 16)

FORCES. (lb) - Max. Comp./Max. Ten. - All forces 250 (lb) or less except when shown.
TOP CHORD 2-3=-1498/101, 3-5=-1352/177, 5-8=-292/64, 8-10=-295/68, 5-7=-346/138, 7-10=-348/138
BOT CHORD 2-15=-277/1321, 13-15=-181/706
WEBS 3-15=-437/174, 5-15=-44/877, 5-13=-618/183, 10-13=-37/926, 10-12=-1116/273

- NOTES-**
- Unbalanced roof live loads have been considered for this design.
 - Wind: ASCE 7-10; Vult=120mph (3-second gust) Vasd=95mph; TCDL=6.0psf; BCDL=6.0psf; h=25ft; B=45ft; L=25ft; eave=4ft; Cat. II; Exp B; Enclosed; MWFRS (directional) and C-C Exterior(2) -1-2-8 to 1-9-8, Interior(1) 1-9-8 to 20-0-0, Exterior(2) 20-0-0 to 23-0-0, Interior(1) 23-0-0 to 25-1-12 zone; cantilever left and right exposed ; end vertical left and right exposed;C-C for members and forces & MWFRS for reactions shown; Lumber DOL=1.60 plate grip DOL=1.60
 - Provide adequate drainage to prevent water ponding.
 - All plates are MT20 plates unless otherwise indicated.
 - Attach MiTek MTHNH18 (Half and Half Plate) on each face of truss with USP NA11 nails (0.131" x 1.5") in pre-punched holes provided. All nail holes must be filled (6 Nails per side 12 nails total).
 - See HINGE PLATE DETAILS for plate placement.
 - Provisions must be made to prevent lateral movement of hinged member(s) during transportation.
 - * This truss has been designed for a live load of 20.0psf on the bottom chord in all areas where a rectangle 3-6-0 tall by 2-0-0 wide will fit between the bottom chord and any other members, with BCDL = 10.0psf.
 - Provide mechanical connection (by others) of truss to bearing plate capable of withstanding 100 lb uplift at joint(s) 2, 12.
 - Graphical purlin representation does not depict the size or the orientation of the purlin along the top and/or bottom chord.

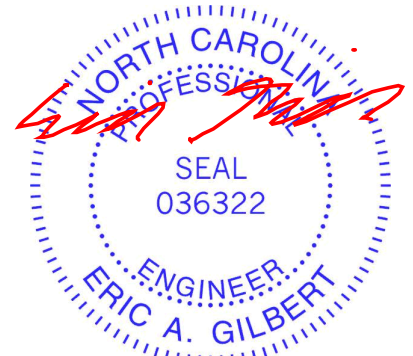

April 20,2020

WARNING - Verify design parameters and READ NOTES ON THIS AND INCLUDED MITEK REFERENCE PAGE MII-7473 rev. 10/03/2015 BEFORE USE.

Design valid for use only with MiTek® connectors. This design is based only upon parameters shown, and is for an individual building component, not a truss system. Before use, the building designer must verify the applicability of design parameters and properly incorporate this design into the overall building design. Bracing indicated is to prevent buckling of individual truss web and/or chord members only. Additional temporary and permanent bracing is always required for stability and to prevent collapse with possible personal injury and property damage. For general guidance regarding the fabrication, storage, delivery, erection and bracing of trusses and truss systems, see ANSIT/TP1 Quality Criteria, DSB-89 and BCSI Building Component Safety Information available from Truss Plate Institute, 218 N. Lee Street, Suite 312, Alexandria, VA 22314.



818 Soundside Road
Edenton, NC 27932

Job 200607RT1	Truss A08	Truss Type Common	Qty 4	Ply 1	FFH-WILSON PLAN 25 PLANTERS GLEN Job Reference (optional)	E14316812
------------------	--------------	----------------------	----------	----------	--	-----------

Carolina Structural Systems, LLC, Ether, NC - 27247,

8.330 s Mar 23 2020 MiTek Industries, Inc. Mon Apr 20 14:38:06 2020 Page 1

ID:ng1sARatyWRgmLmP2hZLLXyQUhk-a9oZ2JfBvL0J6qXlpFmEG5g9ZWXRGhXGffkMCMzOoDV

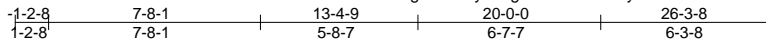

MTHNH18

Scale = 1:83.5

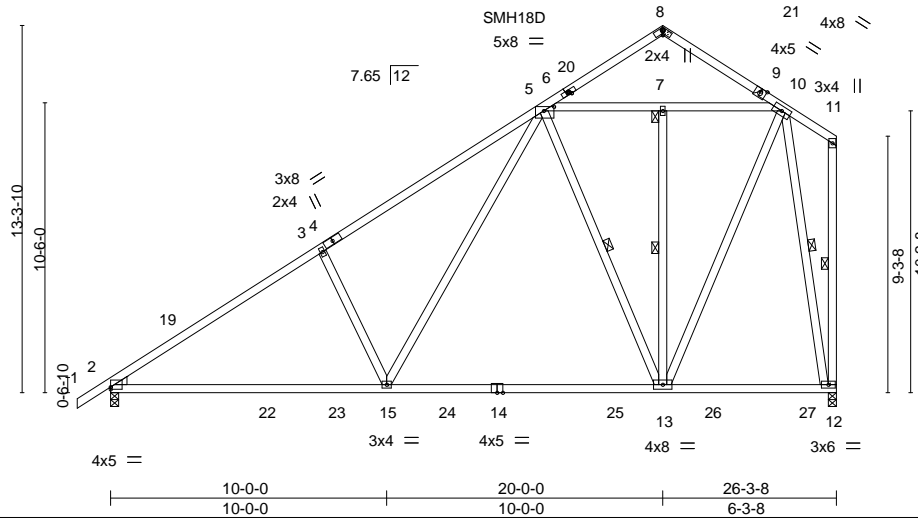

Plate Offsets (X,Y)-- [2:0-0-0,0-1-0], [5:0-4-7,0-1-14], [6:0-1-0,0-1-0], [8:0-1-2,0-1-12]

LOADING (psf)	SPACING-	2-0-0	CSI.	DEFL.	in (loc)	l/defl	L/d	PLATES	GRIP
TCLL 20.0	Plate Grip DOL	1.00	TC 0.60	Vert(LL)	-0.35 13-15	>902	240	MT20	244/190
TCDL 10.0	Lumber DOL	1.15	BC 0.89	Vert(CT)	-0.52 13-15	>602	180	MT18HS	244/190
BCLL 0.0 *	Rep Stress Incr	YES	WB 0.54	Horz(CT)	0.03 12	n/a	n/a		
BCDL 10.0	Code IRC2015/TPI2014		Matrix-MS						
								Weight: 201 lb	FT = 20%

LUMBER-

TOP CHORD 2x4 SP No.1 *Except*
5-10,6-8,8-9: 2x4 SP No.2
BOT CHORD 2x4 SP No.1 *Except*
12-14: 2x4 SP No.2
WEBS 2x4 SP No.2
WEDGE
Left: 2x4 SP No.3

BRACING-

TOP CHORD Structural wood sheathing directly applied or 4-5-11 oc purlins, except end verticals.
BOT CHORD Rigid ceiling directly applied or 10-0-0 oc bracing.
WEBS 1 Row at midpt 5-13, 7-13, 11-12, 10-12
JOINTS 1 Brace at Jt(s): 7

REACTIONS.

(size) 2=0-3-8, 12=0-3-8
Max Horz 2=345(LC 10)
Max Uplift 2=31(LC 11), 12=15(LC 11)
Max Grav 2=1162(LC 16), 12=1188(LC 16)

FORCES. (lb) - Max. Comp./Max. Ten. - All forces 250 (lb) or less except when shown.

TOP CHORD 2-3=-1580/103, 3-5=-1434/178, 5-8=-289/67, 8-10=-293/66, 5-7=-412/136, 7-10=-413/136
BOT CHORD 2-15=-270/1392, 13-15=-174/779, 12-13=-105/262
WEBS 3-15=-438/175, 5-15=-43/873, 5-13=-562/165, 10-13=-20/891, 10-12=-1128/204

NOTES-

- Unbalanced roof live loads have been considered for this design.
- Wind: ASCE 7-10; Vult=120mph (3-second gust) Vasd=95mph; TCDL=6.0psf; BCDL=6.0psf; h=25ft; B=45ft; L=26ft; eave=4ft; Cat. II; Exp B; Enclosed; MWFRS (directional) and C-C Exterior(2) -1-2-8 to 1-9-8, Interior(1) 1-9-8 to 20-0-0, Exterior(2) 20-0-0 to 23-0-0, Interior(1) 23-0-0 to 26-1-12 zone; cantilever left and right exposed ; end vertical left and right exposed; C-C for members and forces & MWFRS for reactions shown; Lumber DOL=1.60 plate grip DOL=1.60
- Provide adequate drainage to prevent water ponding.
- All plates are MT20 plates unless otherwise indicated.
- Attach MiTek MTHNH18 (Half and Half Plate) on each face of truss with USP NA11 nails (0.131" x 1.5") in pre-punched holes provided. All nail holes must be filled (6 Nails per side 12 nails total).
- See HINGE PLATE DETAILS for plate placement.
- Provisions must be made to prevent lateral movement of hinged member(s) during transportation.
- * This truss has been designed for a live load of 20.0psf on the bottom chord in all areas where a rectangle 3-6-0 tall by 2-0-0 wide will fit between the bottom chord and any other members, with BCDL = 10.0psf.
- Provide mechanical connection (by others) of truss to bearing plate capable of withstanding 100 lb uplift at joint(s) 2, 12.
- Graphical purlin representation does not depict the size or the orientation of the purlin along the top and/or bottom chord.



April 20,2020

WARNING - Verify design parameters and READ NOTES ON THIS AND INCLUDED MITEK REFERENCE PAGE MII-7473 rev. 10/03/2015 BEFORE USE.

Design valid for use only with MiTek® connectors. This design is based only upon parameters shown, and is for an individual building component, not a truss system. Before use, the building designer must verify the applicability of design parameters and properly incorporate this design into the overall building design. Bracing indicated is to prevent buckling of individual truss web and/or chord members only. Additional temporary and permanent bracing is always required for stability and to prevent collapse with possible personal injury and property damage. For general guidance regarding the fabrication, storage, delivery, erection and bracing of trusses and truss systems, see ANSITPI Quality Criteria, DSB-89 and BCSI Building Component Safety Information available from Truss Plate Institute, 218 N. Lee Street, Suite 312, Alexandria, VA 22314.



818 Soundside Road
Edenton, NC 27932

Job 200607RT1	Truss A09	Truss Type GABLE	Qty 1	Ply 1	FFH-WILSON PLAN 25 PLANTERS GLEN Job Reference (optional)	E14316813
------------------	--------------	---------------------	----------	----------	--	-----------

Carolina Structural Systems, LLC, Ether, NC - 27247,

8.330 s Mar 23 2020 MiTek Industries, Inc. Mon Apr 20 14:38:08 2020 Page 1
ID:ng1sARatyWRgmLmP2hZLLXyQUhk-XYwJT?hRRyG1L7hxxgoiMwMXPKNVkfNY7zDSHFzOoDT



MTHNH18

Scale = 1:83.4

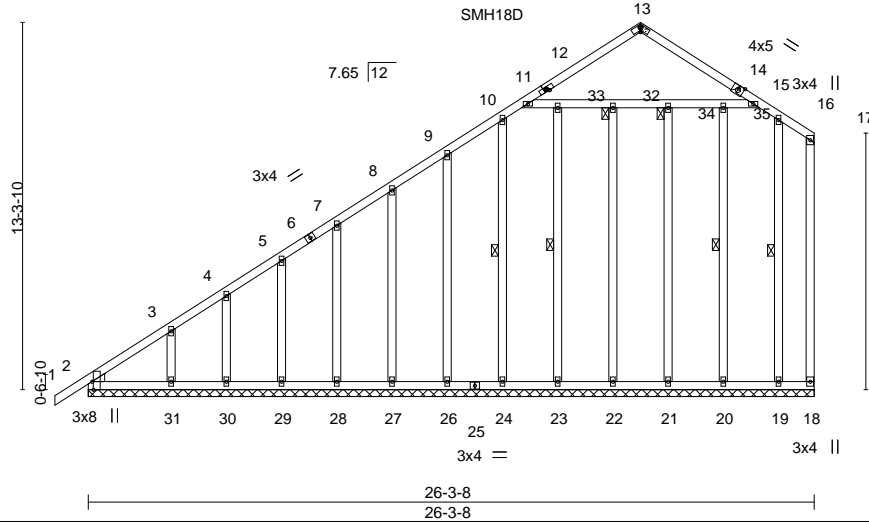

Plate Offsets (X,Y)-- [2:0-3-8,Edge], [2:0-1-1,0-5-5], [2:0-0-8,0-0-13], [12:0-1-0,0-1-0], [13:0-1-2,0-1-12]

LOADING (psf)	SPACING-	2-0-0	CSI.	DEFL.	in (loc)	l/defl	L/d	PLATES	GRIP
TCLL 20.0	Plate Grip DOL	1.00	TC 0.45	Vert(LL)	-0.00	1	n/r	MT20	244/190
TCDL 10.0	Lumber DOL	1.15	BC 0.21	Vert(CT)	0.00	1	n/r	MT18HS	244/190
BCLL 0.0 *	Rep Stress Incr	YES	WB 0.29	Horz(CT)	-0.00	18	n/a		
BCDL 10.0	Code	IRC2015/TPI2014	Matrix-S						
								Weight: 248 lb	FT = 20%

LUMBER-
TOP CHORD 2x4 SP No.1 *Except*
12-13,13-14: 2x4 SP No.2
BOT CHORD 2x4 SP No.2
WEBS 2x4 SP No.2
OTHERS 2x4 SP No.2
WEDGE
Left: 2x4 SP No.2

BRACING-
TOP CHORD Structural wood sheathing directly applied or 6-0-0 oc purlins, except end verticals.
BOT CHORD Rigid ceiling directly applied or 10-0-0 oc bracing.
WEBS 1 Row at midpt 23-33, 10-24, 20-35, 16-19
JOINTS 1 Brace at Jt(s): 32, 34

REACTIONS. All bearings 26-3-8.
(lb) - Max Horz 2=344(LC 10)
Max Uplift All uplift 100 lb or less at joint(s) 2, 22, 23, 24, 26, 27, 28, 29, 30, 31, 21, 19 except 18=-103(LC 18)
Max Grav All reactions 250 lb or less at joint(s) 18, 22, 23, 26, 27, 28, 29, 30, 31, 21, 20 except 2=264(LC 17), 24=460(LC 16), 19=448(LC 1)

FORCES. (lb) - Max. Comp./Max. Ten. - All forces 250 (lb) or less except when shown.
TOP CHORD 2-3=-399/378, 3-4=-316/300, 4-5=-273/268, 11-13=-311/80, 13-15=-304/77
WEBS 10-24=-420/181, 16-19=-451/236

- NOTES-**
- Unbalanced roof live loads have been considered for this design.
 - Wind: ASCE 7-10; Vult=120mph (3-second gust) Vasd=95mph; TCDL=6.0psf; BCDL=6.0psf; h=25ft; B=45ft; L=26ft; eave=2ft; Cat. II; Exp B; Enclosed; MWFRS (directional) and C-C Corner(3) -1-2-8 to 1-9-8, Exterior(2) 1-9-8 to 20-0-0, Corner(3) 20-0-0 to 23-0-0, Exterior(2) 23-0-0 to 26-1-12 zone; cantilever left and right exposed; end vertical left and right exposed; C-C for members and forces & MWFRS for reactions shown; Lumber DOL=1.60 plate grip DOL=1.60
 - Truss designed for wind loads in the plane of the truss only. For studs exposed to wind (normal to the face), see Standard Industry Gable End Details as applicable, or consult qualified building designer as per ANSI/TPI 1.
 - All plates are MT20 plates unless otherwise indicated.
 - All plates are 2x4 MT20 unless otherwise indicated.
 - Attach MiTek MTHNH18 (Half and Half Plate) on each face of truss with USP NA11 nails (0.131" x 1.5") in pre-punched holes provided. All nail holes must be filled (6 Nails per side 12 nails total).
 - See HINGE PLATE DETAILS for plate placement.
 - Provisions must be made to prevent lateral movement of hinged member(s) during transportation.
 - Gable requires continuous bottom chord bearing.
 - Gable studs spaced at 2-0-0 oc.
 - * This truss has been designed for a live load of 20.0psf on the bottom chord in all areas where a rectangle 3-6-0 tall by 2-0-0 wide will fit between the bottom chord and any other members.
 - Provide mechanical connection (by others) of truss to bearing plate capable of withstanding 100 lb uplift at joint(s) 2, 22, 23, 24, 26, 27, 28, 29, 30, 31, 21, 19 except (jt=lb) 18=103.

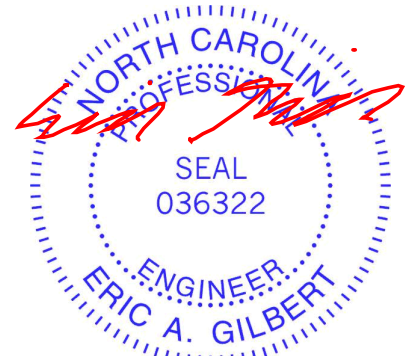

April 20,2020

WARNING - Verify design parameters and READ NOTES ON THIS AND INCLUDED MITEK REFERENCE PAGE MII-7473 rev. 10/03/2015 BEFORE USE.

Design valid for use only with MiTek® connectors. This design is based only upon parameters shown, and is for an individual building component, not a truss system. Before use, the building designer must verify the applicability of design parameters and properly incorporate this design into the overall building design. Bracing indicated is to prevent buckling of individual truss web and/or chord members only. Additional temporary and permanent bracing is always required for stability and to prevent collapse with possible personal injury and property damage. For general guidance regarding the fabrication, storage, delivery, erection and bracing of trusses and truss systems, see **ANSI/TPI1 Quality Criteria, DSB-89 and BCSI Building Component Safety Information** available from Truss Plate Institute, 218 N. Lee Street, Suite 312, Alexandria, VA 22314.



818 Soundside Road
Edenton, NC 27932

Job 200607RT1	Truss B01	Truss Type Common	Qty 6	Ply 1	FFH-WILSON PLAN 25 PLANTERS GLEN	E14316814
------------------	--------------	----------------------	----------	----------	----------------------------------	-----------

Carolina Structural Systems, LLC, Ether, NC - 27247,

8.330 s Mar 23 2020 MiTek Industries, Inc. Mon Apr 20 14:38:09 2020 Page 1
ID:ng1sARatyWRgmLmP2hZLLXyQUhk-?kUigLi3CGOuzHGtVOJxuklfZkbnT1hiMdy0phzOoDS

-1-2-8	6-1-1	12-0-0	12-0-9	18-0-0	23-11-8	24-0-0	29-10-15	36-0-0	37-2-8
1-2-8	6-1-1	5-10-15	0-0-9	5-11-7	5-11-7	0-0-9	5-10-15	6-1-1	1-2-8

Scale = 1:84.5

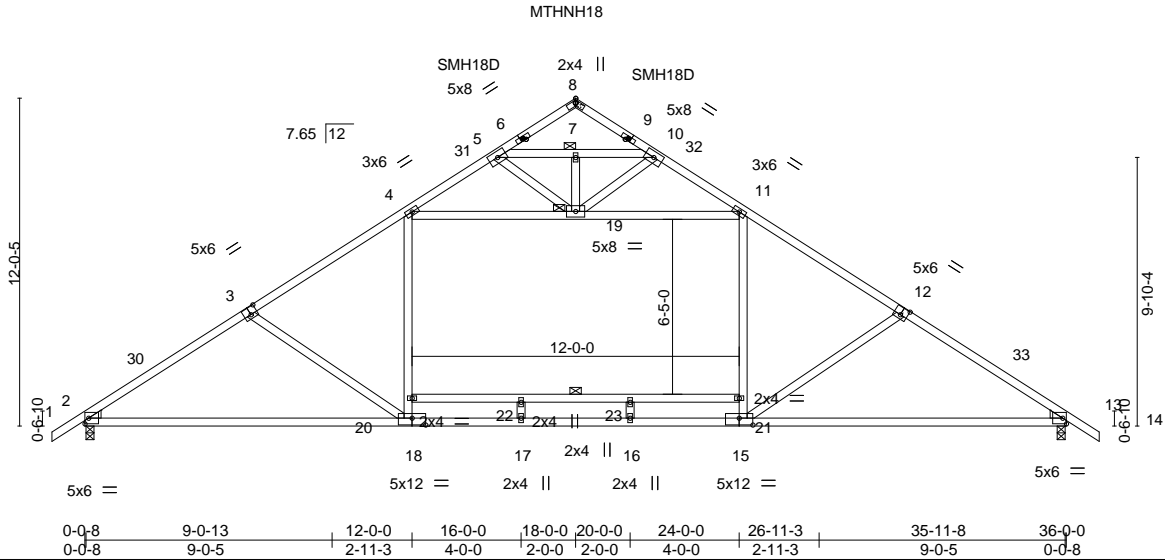

Plate Offsets (X,Y)-- [2:0-0-13,0-0-8], [2:0-5-5,0-1-1], [3:0-3-0,0-3-4], [6:0-1-0,0-1-0], [8:0-1-2,0-1-12], [9:0-1-0,0-1-0], [12:0-3-0,0-3-4], [13:0-5-4,0-1-0], [13:0-0-13,0-0-8], [15:0-6-0,0-3-0], [18:0-6-0,0-3-0]

LOADING (psf)	SPACING-	CSI.	DEFL.	in (loc)	l/defl	L/d	PLATES	GRIP
TCLL 20.0	2-0-0	TC 0.68	Vert(LL)	-1.08	18-26	>399	MT20	244/190
TCDL 10.0	Plate Grip DOL 1.00	BC 0.65	Vert(CT)	-1.23	18-26	>351	MT18HS	244/190
BCLL 0.0 *	Lumber DOL 1.15	WB 0.60	Horz(CT)	0.07	13	n/a		
BCDL 10.0	Rep Stress Incr YES	Matrix-MS						
	Code IRC2015/TPI2014						Weight: 225 lb	FT = 20%

LUMBER-
TOP CHORD 2x4 SP No.2 *Except*
3-6,9-12: 2x4 SP DSS
BOT CHORD 2x4 SP DSS
WEBS 2x4 SP No.2
WEDGE
Left: 2x4 SP No.2 , Right: 2x4 SP No.2

BRACING-
TOP CHORD Structural wood sheathing directly applied or 3-7-14 oc purlins.
BOT CHORD Rigid ceiling directly applied or 10-0-0 oc bracing.
WEBS 1 Row at midpt 20-21
JOINTS 1 Brace at Jt(s): 19, 7

REACTIONS. (size) 2=0-3-8, 13=0-3-8
Max Horz 2=-216(LC 9)
Max Uplift 2=-41(LC 11), 13=-41(LC 11)
Max Grav 2=1513(LC 1), 13=1513(LC 1)

FORCES. (lb) - Max. Comp./Max. Ten. - All forces 250 (lb) or less except when shown.
TOP CHORD 2-3=-2184/136, 3-4=-1879/129, 4-5=-594/135, 10-11=-594/135, 11-12=-1879/129,
12-13=-2184/136, 5-7=-386/140, 7-10=-386/140
BOT CHORD 2-18=-13/1773, 17-18=0/1548, 16-17=0/1548, 15-16=0/1548, 13-15=-17/1773
WEBS 12-15=-471/118, 3-18=-472/118, 18-20=0/421, 4-20=0/426, 15-21=0/421, 11-21=0/426,
4-19=-1058/76, 11-19=-1059/76, 5-19=-177/267, 10-19=-177/267

- NOTES-**
- Unbalanced roof live loads have been considered for this design.
 - Wind: ASCE 7-10; Vult=120mph (3-second gust) Vasd=95mph; TCCL=6.0psf; BCDL=6.0psf; h=25ft; B=45ft; L=36ft; eave=5ft; Cat. II; Exp B; Enclosed; MWFRS (directional) and C-C Exterior(2) -1-2-8 to 2-4-11, Interior(1) 2-4-11 to 18-0-0, Exterior(2) 18-0-0 to 21-7-3, Interior(1) 21-7-3 to 37-2-8 zone; cantilever left and right exposed ; end vertical left and right exposed;C-C for members and forces & MWFRS for reactions shown; Lumber DOL=1.60 plate grip DOL=1.60
 - Provide adequate drainage to prevent water ponding.
 - All plates are MT20 plates unless otherwise indicated.
 - Attach MiTek MTHNH18 (Half and Half Plate) on each face of truss with USP NA11 nails (0.131" x 1.5") in pre-punched holes provided. All nail holes must be filled (6 Nails per side 12 nails total).
 - See HINGE PLATE DETAILS for plate placement.
 - Provisions must be made to prevent lateral movement of hinged member(s) during transportation.
 - * This truss has been designed for a live load of 20.0psf on the bottom chord in all areas where a rectangle 3-6-0 tall by 2-0-0 wide will fit between the bottom chord and any other members.
 - Provide mechanical connection (by others) of truss to bearing plate capable of withstanding 100 lb uplift at joint(s) 2, 13.
 - Graphical purlin representation does not depict the size or the orientation of the purlin along the top and/or bottom chord.

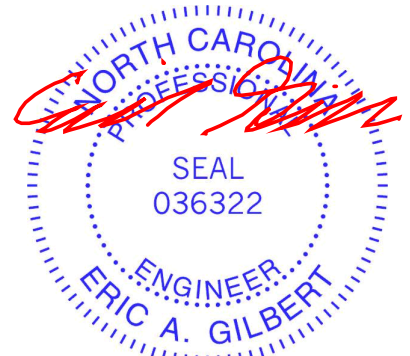

April 20,2020

WARNING - Verify design parameters and READ NOTES ON THIS AND INCLUDED MITEK REFERENCE PAGE MII-7473 rev. 10/03/2015 BEFORE USE.

Design valid for use only with MiTek® connectors. This design is based only upon parameters shown, and is for an individual building component, not a truss system. Before use, the building designer must verify the applicability of design parameters and properly incorporate this design into the overall building design. Bracing indicated is to prevent buckling of individual truss web and/or chord members only. Additional temporary and permanent bracing is always required for stability and to prevent collapse with possible personal injury and property damage. For general guidance regarding the fabrication, storage, delivery, erection and bracing of trusses and truss systems, see ANSI/TPI1 Quality Criteria, DSB-89 and BCSI Building Component Safety Information available from Truss Plate Institute, 218 N. Lee Street, Suite 312, Alexandria, VA 22314.



818 Soundside Road
Edenton, NC 27932

Job 200607RT1	Truss B02	Truss Type GABLE	Qty 1	Ply 1	FFH-WILSON PLAN 25 PLANTERS GLEN Job Reference (optional)	E14316815
------------------	--------------	---------------------	----------	----------	--	-----------

Carolina Structural Systems, LLC, Ether, NC - 27247,

8.330 s Mar 23 2020 MiTek Industries, Inc. Mon Apr 20 14:38:11 2020 Page 1
ID:ng1sARatyWRgmLmP2hZLLXyQUhk-x7bS51jKktebCbQGcoLPz9O8pXRmx3r?pxR7tazOoDQ

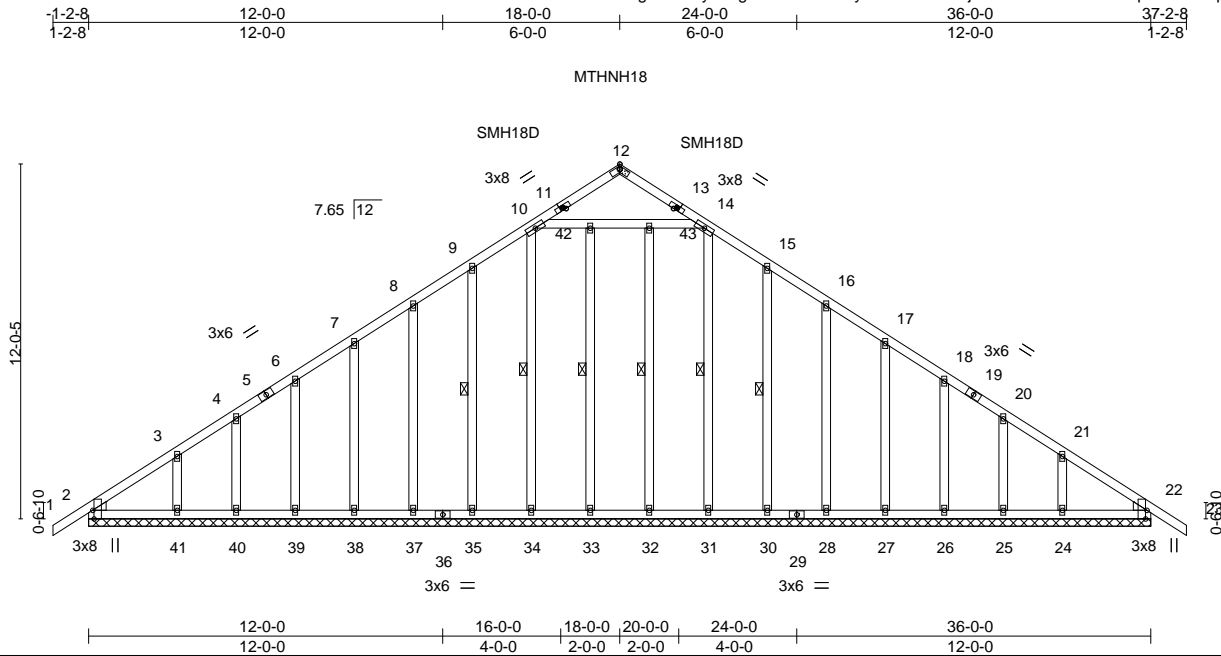

Scale = 1:78.1

Plate Offsets (X,Y)-- [2:0-3-8,Edge], [2:0-1-1,0-5-5], [2:0-0-8,0-0-13], [11:0-1-0,0-1-0], [12:0-1-2,0-1-12], [13:0-1-0,0-1-0], [15:0-0-0,0-0-0], [16:0-0-0,0-0-0], [17:0-0-0,0-0-0], [18:0-0-0,0-0-0], [20:0-0-0,0-0-0], [21:0-0-0,0-0-0], [22:0-1-0,0-5-4], [22:0-0-8,0-0-13]

LOADING (psf)	SPACING-	CSI.	DEFL.	in (loc)	l/defl	L/d	PLATES	GRIP
TCLL 20.0	Plate Grip DOL 1.00	TC 0.12	Vert(LL) -0.00	23	n/r	120	MT20	244/190
TCDL 10.0	Lumber DOL 1.15	BC 0.05	Vert(CT) 0.00	22	n/r	120	MT18HS	244/190
BCLL 0.0 *	Rep Stress Incr YES	WB 0.11	Horz(CT) 0.01	22	n/a	n/a		
BCDL 10.0	Code IRC2015/TPI2014	Matrix-S					Weight: 280 lb	FT = 20%

LUMBER-
TOP CHORD 2x4 SP No.2
BOT CHORD 2x4 SP No.2
WEBS 2x4 SP No.2
OTHERS 2x4 SP No.2
WEDGE
Left: 2x4 SP No.2 , Right: 2x4 SP No.2

BRACING-
TOP CHORD Structural wood sheathing directly applied or 6'-0-0 oc purlins.
BOT CHORD Rigid ceiling directly applied or 10'-0-0 oc bracing.
WEBS 1 Row at midpt 33-42, 10-34, 9-35, 32-43, 14-31, 15-30

REACTIONS. All bearings 36-0-0.
(lb) - Max Horz 2=216(LC 10)
Max Uplift All uplift 100 lb or less at joint(s) 2, 35, 37, 38, 39, 40, 41, 30, 28, 27, 26, 25, 24
Max Grav All reactions 250 lb or less at joint(s) 2, 22, 33, 35, 37, 38, 39, 40, 41, 32, 30, 28, 27, 26, 25, 24 except 34=281(LC 16), 31=268(LC 1)

FORCES. (lb) - Max. Comp./Max. Ten. - All forces 250 (lb) or less except when shown.

- NOTES-**
- Unbalanced roof live loads have been considered for this design.
 - Wind: ASCE 7-10; Vult=120mph (3-second gust) Vasd=95mph; TCDL=6.0psf; BCDL=6.0psf; h=25ft; B=45ft; L=36ft; eave=2ft; Cat. II; Exp B; Enclosed; MWFRS (directional) and C-C Corner(3) -1-2-8 to 2-4-11, Exterior(2) 2-4-11 to 18-0-0, Corner(3) 18-0-0 to 21-7-3, Exterior(2) 21-7-3 to 37-2-8 zone; cantilever left and right exposed ; end vertical left and right exposed;C-C for members and forces & MWFRS for reactions shown; Lumber DOL=1.60 plate grip DOL=1.60
 - Truss designed for wind loads in the plane of the truss only. For studs exposed to wind (normal to the face), see Standard Industry Gable End Details as applicable, or consult qualified building designer as per ANSI/TPI 1.
 - All plates are MT20 plates unless otherwise indicated.
 - All plates are 2x4 MT20 unless otherwise indicated.
 - Attach MiTek MTHNH18 (Half and Half Plate) on each face of truss with USP NA11 nails (0.131" x 1.5") in pre-punched holes provided. All nail holes must be filled (6 Nails per side 12 nails total).
 - See HINGE PLATE DETAILS for plate placement.
 - Provisions must be made to prevent lateral movement of hinged member(s) during transportation.
 - Gable requires continuous bottom chord bearing.
 - Gable studs spaced at 2'-0-0 oc.
 - * This truss has been designed for a live load of 20.0psf on the bottom chord in all areas where a rectangle 3'-6-0 tall by 2'-0-0 wide will fit between the bottom chord and any other members.
 - Provide mechanical connection (by others) of truss to bearing plate capable of withstanding 100 lb uplift at joint(s) 2, 35, 37, 38, 39, 40, 41, 30, 28, 27, 26, 25, 24.



April 20,2020

WARNING - Verify design parameters and READ NOTES ON THIS AND INCLUDED MITEK REFERENCE PAGE MII-7473 rev. 10/03/2015 BEFORE USE.

Design valid for use only with MiTek® connectors. This design is based only upon parameters shown, and is for an individual building component, not a truss system. Before use, the building designer must verify the applicability of design parameters and properly incorporate this design into the overall building design. Bracing indicated is to prevent buckling of individual truss web and/or chord members only. Additional temporary and permanent bracing is always required for stability and to prevent collapse with possible personal injury and property damage. For general guidance regarding the fabrication, storage, delivery, erection and bracing of trusses and truss systems, see **ANSI/TPI1 Quality Criteria, DSB-89 and BCSI Building Component Safety Information** available from Truss Plate Institute, 218 N. Lee Street, Suite 312, Alexandria, VA 22314.



818 Soundside Road
Edenton, NC 27932

Job 200607RT1	Truss C01	Truss Type Common	Qty 5	Ply 1	FFH-WILSON PLAN 25 PLANTERS GLEN	E14316816
------------------	--------------	----------------------	----------	----------	----------------------------------	-----------

Carolina Structural Systems, LLC, Ether, NC - 27247,

8.330 s Mar 23 2020 MiTek Industries, Inc. Mon Apr 20 14:38:13 2020 Page 1

ID:ng1sARatyWRgmLmP2hZLLXyQUhk-tVjCWjlaGUuJSvaekDOT2aTPKL_EPx5IGFwDySzOoDO

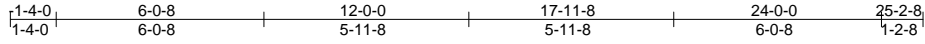

4x5 ||

Scale = 1:67.0

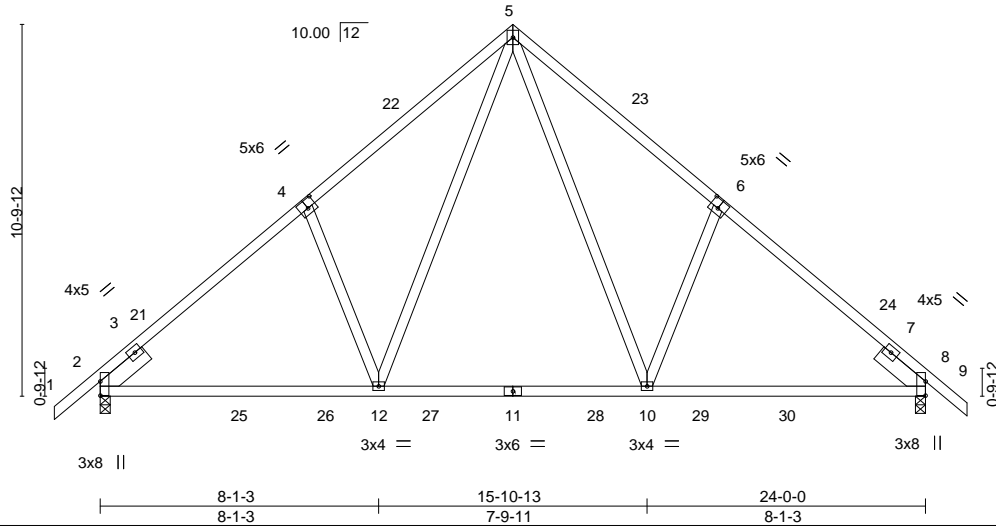

Plate Offsets (X,Y)-- [2:Edge,0-0-0], [4:0-3-0,0-3-0], [6:0-3-0,0-3-0], [8:Edge,0-0-0]

LOADING (psf)	SPACING-	2-0-0	CSI.	DEFL.	in (loc)	l/defl	L/d	PLATES	GRIP
TCLL 20.0	Plate Grip DOL	1.00	TC 0.44	Vert(LL)	-0.14 10-12	>999	240	MT20	244/190
TCDL 10.0	Lumber DOL	1.15	BC 0.62	Vert(CT)	-0.22 10-12	>999	180		
BCLL 0.0 *	Rep Stress Incr	YES	WB 0.19	Horz(CT)	0.03 8	n/a	n/a		
BCDL 10.0	Code	IRC2015/TPI2014	Matrix-MS					Weight: 145 lb	FT = 20%

LUMBER-
TOP CHORD 2x4 SP No.2
BOT CHORD 2x4 SP No.2
WEBS 2x4 SP No.2
SLIDER Left 2x6 SP No.2 -H 1-7-15, Right 2x6 SP No.2 -H 1-7-15

BRACING-
TOP CHORD Structural wood sheathing directly applied or 4-10-7 oc purlins.
BOT CHORD Rigid ceiling directly applied or 10-0-0 oc bracing.

REACTIONS. (size) 2=0-3-8, 8=0-3-8
Max Horz 2=200(LC 10)
Max Uplift 2=-41(LC 11), 8=-37(LC 11)
Max Grav 2=1077(LC 16), 8=1069(LC 17)

FORCES. (lb) - Max. Comp./Max. Ten. - All forces 250 (lb) or less except when shown.
TOP CHORD 2-4=-1202/94, 4-5=-1127/190, 5-6=-1128/192, 6-8=-1202/95
BOT CHORD 2-12=0/986, 10-12=0/663, 8-10=0/889
WEBS 5-10=-71/607, 6-10=-322/169, 5-12=-71/605, 4-12=-322/169

- NOTES-**
- Unbalanced roof live loads have been considered for this design.
 - Wind: ASCE 7-10; Vult=120mph (3-second gust) Vasd=95mph; TC DL=6.0psf; BCDL=6.0psf; h=25ft; B=45ft; L=24ft; eave=4ft; Cat. II; Exp B; Enclosed; MWFRS (directional) and C-C Exterior(2) -1-4-0 to 1-8-0, Interior(1) 1-8-0 to 12-0-0, Exterior(2) 12-0-0 to 15-0-0, Interior(1) 15-0-0 to 25-2-8 zone; cantilever left and right exposed; end vertical left and right exposed; C-C for members and forces & MWFRS for reactions shown; Lumber DOL=1.60 plate grip DOL=1.60
 - * This truss has been designed for a live load of 20.0psf on the bottom chord in all areas where a rectangle 3-6-0 tall by 2-0-0 wide will fit between the bottom chord and any other members, with BCDL = 10.0psf.
 - Provide mechanical connection (by others) of truss to bearing plate capable of withstanding 100 lb uplift at joint(s) 2, 8.

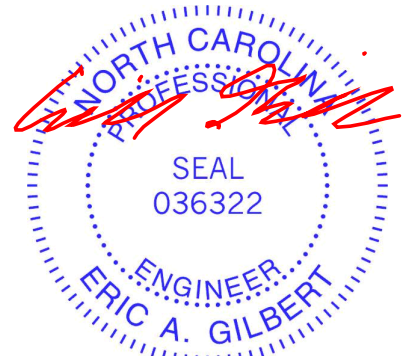

April 20,2020

WARNING - Verify design parameters and READ NOTES ON THIS AND INCLUDED MITEK REFERENCE PAGE MII-7473 rev. 10/03/2015 BEFORE USE.
Design valid for use only with MiTek® connectors. This design is based only upon parameters shown, and is for an individual building component, not a truss system. Before use, the building designer must verify the applicability of design parameters and properly incorporate this design into the overall building design. Bracing indicated is to prevent buckling of individual truss web and/or chord members only. Additional temporary and permanent bracing is always required for stability and to prevent collapse with possible personal injury and property damage. For general guidance regarding the fabrication, storage, delivery, erection and bracing of trusses and truss systems, see **ANSI/TPI1 Quality Criteria, DSB-89 and BCSI Building Component Safety Information** available from Truss Plate Institute, 218 N. Lee Street, Suite 312, Alexandria, VA 22314.

ENGINEERING BY
TRENCO
A MiTek Affiliate
818 Soundside Road
Edenton, NC 27932

Job 200607RT1	Truss C02	Truss Type Common Supported Gable	Qty 1	Ply 1	FFH-WILSON PLAN 25 PLANTERS GLEN Job Reference (optional)	E14316817
------------------	--------------	--------------------------------------	----------	----------	--	-----------

Carolina Structural Systems, LLC, Ether, NC - 27247,

8.330 s Mar 23 2020 MiTek Industries, Inc. Mon Apr 20 14:38:14 2020 Page 1
ID:ng1sARatyWRgmLmP2hZLLXyQUhk-LiHbj2IC1o0A328rHxv6bn0eVISP8PhrVvgnUvzOoDN

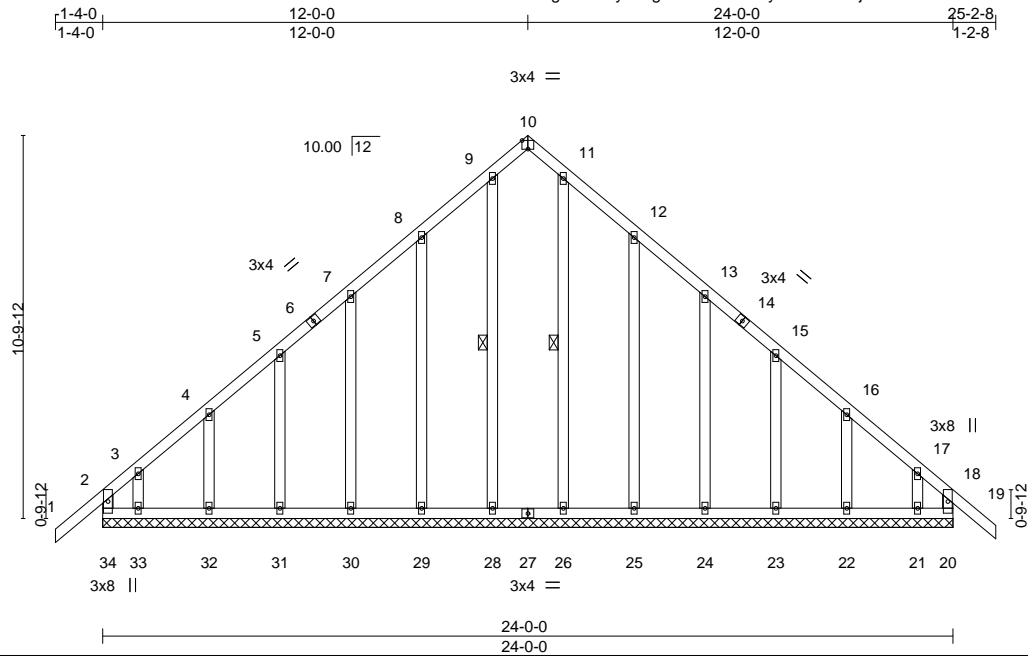

Plate Offsets (X,Y)--		[10:0-2-0,Edge]	
LOADING (psf)	SPACING-	2-0-0	CSI.
TCLL 20.0	Plate Grip DOL	1.00	TC 0.16
TCDL 10.0	Lumber DOL	1.15	BC 0.11
BCLL 0.0 *	Rep Stress Incr	YES	WB 0.17
BCDL 10.0	Code	IRC2015/TPI2014	Matrix-R
DEFL.	in (loc)	l/defl	L/d
Vert(LL)	-0.01	19	n/r
Vert(CT)	-0.01	19	n/r
Horz(CT)	0.01	20	n/a
PLATES	GRIP		
MT20	244/190		
Weight: 183 lb		FT = 20%	

LUMBER-
TOP CHORD 2x4 SP No.2
BOT CHORD 2x4 SP No.2
WEBS 2x4 SP No.2
OTHERS 2x4 SP No.2

BRACING-
TOP CHORD Structural wood sheathing directly applied or 6-0-0 oc purlins, except end verticals.
BOT CHORD Rigid ceiling directly applied or 10-0-0 oc bracing.
WEBS 1 Row at midpt 9-28, 11-26

REACTIONS. All bearings 24-0-0.
(lb) - Max Horz 34=216(LC 10)
Max Uplift All uplift 100 lb or less at joint(s) 34, 20, 29, 30, 31, 32, 25, 24, 23, 22 except 33=-115(LC 8), 21=-112(LC 11)
Max Grav All reactions 250 lb or less at joint(s) 20, 28, 29, 30, 31, 32, 33, 26, 25, 24, 23, 22, 21 except 34=254(LC 17)

FORCES. (lb) - Max. Comp./Max. Ten. - All forces 250 (lb) or less except when shown.

NOTES-

- Unbalanced roof live loads have been considered for this design.
- Wind: ASCE 7-10; Vult=120mph (3-second gust) Vasd=95mph; TCDL=6.0psf; BCDL=6.0psf; h=25ft; B=45ft; L=24ft; eave=2ft; Cat. II; Exp B; Enclosed; MWFRS (directional) and C-C Corner(3) -1-4-0 to 1-8-0, Exterior(2) 1-8-0 to 12-0-0, Corner(3) 12-0-0 to 15-0-0, Exterior(2) 15-0-0 to 25-2-8 zone; cantilever left and right exposed; end vertical left and right exposed; C-C for members and forces & MWFRS for reactions shown; Lumber DOL=1.60 plate grip DOL=1.60
- Truss designed for wind loads in the plane of the truss only. For studs exposed to wind (normal to the face), see Standard Industry Gable End Details as applicable, or consult qualified building designer as per ANSI/TPI 1.
- All plates are 2x4 MT20 unless otherwise indicated.
- Gable requires continuous bottom chord bearing.
- Truss to be fully sheathed from one face or securely braced against lateral movement (i.e. diagonal web).
- Gable studs spaced at 2-0-0 oc.
- * This truss has been designed for a live load of 20.0psf on the bottom chord in all areas where a rectangle 3-6-0 tall by 2-0-0 wide will fit between the bottom chord and any other members.
- Provide mechanical connection (by others) of truss to bearing plate capable of withstanding 100 lb uplift at joint(s) 34, 20, 29, 30, 31, 32, 25, 24, 23, 22 except (jt=lb) 33=115, 21=112.

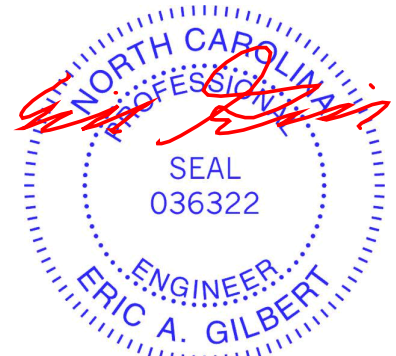

April 20,2020

WARNING - Verify design parameters and READ NOTES ON THIS AND INCLUDED MITEK REFERENCE PAGE MII-7473 rev. 10/03/2015 BEFORE USE.

Design valid for use only with MiTek® connectors. This design is based only upon parameters shown, and is for an individual building component, not a truss system. Before use, the building designer must verify the applicability of design parameters and properly incorporate this design into the overall building design. Bracing indicated is to prevent buckling of individual truss web and/or chord members only. Additional temporary and permanent bracing is always required for stability and to prevent collapse with possible personal injury and property damage. For general guidance regarding the fabrication, storage, delivery, erection and bracing of trusses and truss systems, see **ANSI/TPI1 Quality Criteria, DSB-89 and BCSI Building Component Safety Information** available from Truss Plate Institute, 218 N. Lee Street, Suite 312, Alexandria, VA 22314.



818 Soundside Road
Edenton, NC 27932

Job 200607RT1	Truss C03	Truss Type Common	Qty 8	Ply 1	FFH-WILSON PLAN 25 PLANTERS GLEN Job Reference (optional)	E14316818
------------------	--------------	----------------------	----------	----------	--	-----------

Carolina Structural Systems, LLC, Ether, NC - 27247,

8.330 s Mar 23 2020 MiTek Industries, Inc. Mon Apr 20 14:38:15 2020 Page 1
ID:ng1sARatyWRgmLmP2hZLLXyQUhk-purzxOmqq681hCj1reQL8?Ylo9fatrbakZPK0LzOoDM

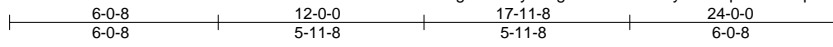

Scale = 1:66.7

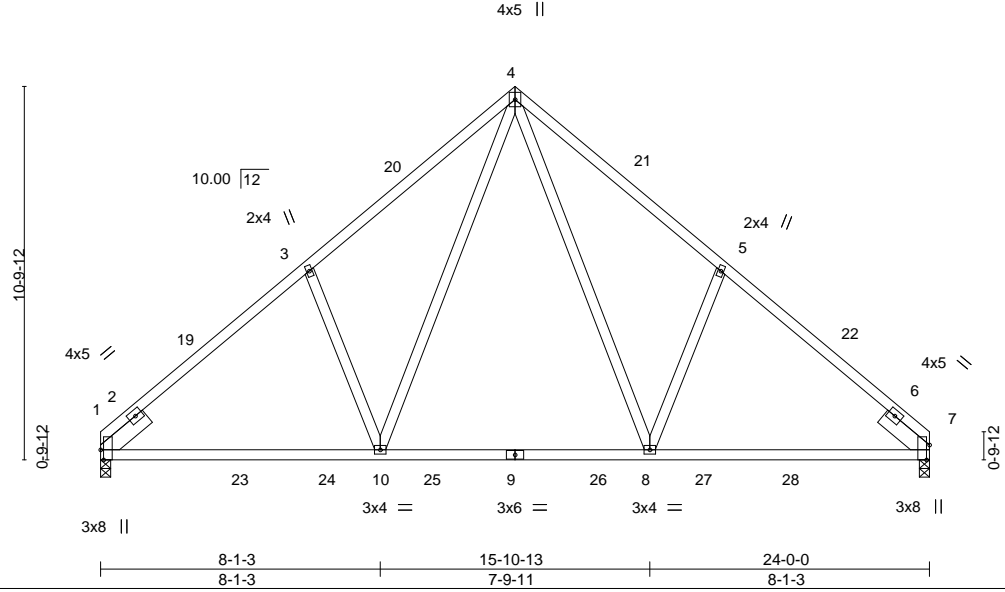

Plate Offsets (X,Y)-- [1:0-3-8,Edge], [7:0-5-3,Edge]

LOADING (psf)	SPACING-	2-0-0	CSI.	DEFL.	in (loc)	l/defl	L/d	PLATES	GRIP
TCLL 20.0	Plate Grip DOL	1.00	TC 0.44	Vert(LL)	-0.14	8-10	>999	MT20	244/190
TCDL 10.0	Lumber DOL	1.15	BC 0.63	Vert(CT)	-0.21	8-10	>999		
BCLL 0.0 *	Rep Stress Incr	YES	WB 0.19	Horz(CT)	0.03	7	n/a		
BCDL 10.0	Code	IRC2015/TPI2014	Matrix-MS						
								Weight: 140 lb	FT = 20%

LUMBER-
TOP CHORD 2x4 SP No.2
BOT CHORD 2x4 SP No.2
WEBS 2x4 SP No.2
SLIDER Left 2x6 SP No.2 -H 1-7-15, Right 2x6 SP No.2 -H 1-7-15

BRACING-
TOP CHORD Structural wood sheathing directly applied or 4-11-5 oc purlins.
BOT CHORD Rigid ceiling directly applied or 10-0-0 oc bracing.

REACTIONS. (size) 1=0-3-8, 7=0-3-8
Max Horz 1=-180(LC 9)
Max Uplift 1=-7(LC 11), 7=-7(LC 11)
Max Grav 1=1004(LC 16), 7=1004(LC 17)

FORCES. (lb) - Max. Comp./Max. Ten. - All forces 250 (lb) or less except when shown.
TOP CHORD 1-3=-1209/103, 3-4=-1138/203, 4-5=-1138/203, 5-7=-1209/103
BOT CHORD 1-10=0/984, 8-10=0/657, 7-8=0/885
WEBS 4-8=-74/616, 5-8=-323/171, 4-10=-74/616, 3-10=-323/171

- NOTES-**
- Unbalanced roof live loads have been considered for this design.
 - Wind: ASCE 7-10; Vult=120mph (3-second gust) Vasd=95mph; TC DL=6.0psf; BCDL=6.0psf; h=25ft; B=45ft; L=24ft; eave=4ft; Cat. II; Exp B; Enclosed; MWFRS (directional) and C-C Exterior(2) 0-0-0 to 3-0-0, Interior(1) 3-0-0 to 12-0-0, Exterior(2) 12-0-0 to 15-0-0, Interior(1) 15-0-0 to 24-0-0 zone; cantilever left and right exposed; end vertical left and right exposed; C-C for members and forces & MWFRS for reactions shown; Lumber DOL=1.60 plate grip DOL=1.60
 - * This truss has been designed for a live load of 20.0psf on the bottom chord in all areas where a rectangle 3-6-0 tall by 2-0-0 wide will fit between the bottom chord and any other members, with BCDL = 10.0psf.
 - Provide mechanical connection (by others) of truss to bearing plate capable of withstanding 100 lb uplift at joint(s) 1, 7.



April 20,2020

WARNING - Verify design parameters and READ NOTES ON THIS AND INCLUDED MITEK REFERENCE PAGE MII-7473 rev. 10/03/2015 BEFORE USE.

Design valid for use only with MiTek® connectors. This design is based only upon parameters shown, and is for an individual building component, not a truss system. Before use, the building designer must verify the applicability of design parameters and properly incorporate this design into the overall building design. Bracing indicated is to prevent buckling of individual truss web and/or chord members only. Additional temporary and permanent bracing is always required for stability and to prevent collapse with possible personal injury and property damage. For general guidance regarding the fabrication, storage, delivery, erection and bracing of trusses and truss systems, see **ANSI/TPI1 Quality Criteria, DSB-89 and BCSI Building Component Safety Information** available from Truss Plate Institute, 218 N. Lee Street, Suite 312, Alexandria, VA 22314.



818 Soundside Road
Edenton, NC 27932

Job 200607RT1	Truss D01	Truss Type Common Girder	Qty 1	Ply 1	FFH-WILSON PLAN 25 PLANTERS GLEN Job Reference (optional)	E14316819
------------------	--------------	-----------------------------	----------	----------	--	-----------

Carolina Structural Systems, LLC, Ether, NC - 27247,

8.330 s Mar 23 2020 MiTek Industries, Inc. Mon Apr 20 14:38:16 2020 Page 1
ID:ng1sARatyWRgmLmP2hZLLXyQUhk-l4PL8knSZPGuJMIDPMxagC5wCY5Dcl6kzD9tZnzOoDL

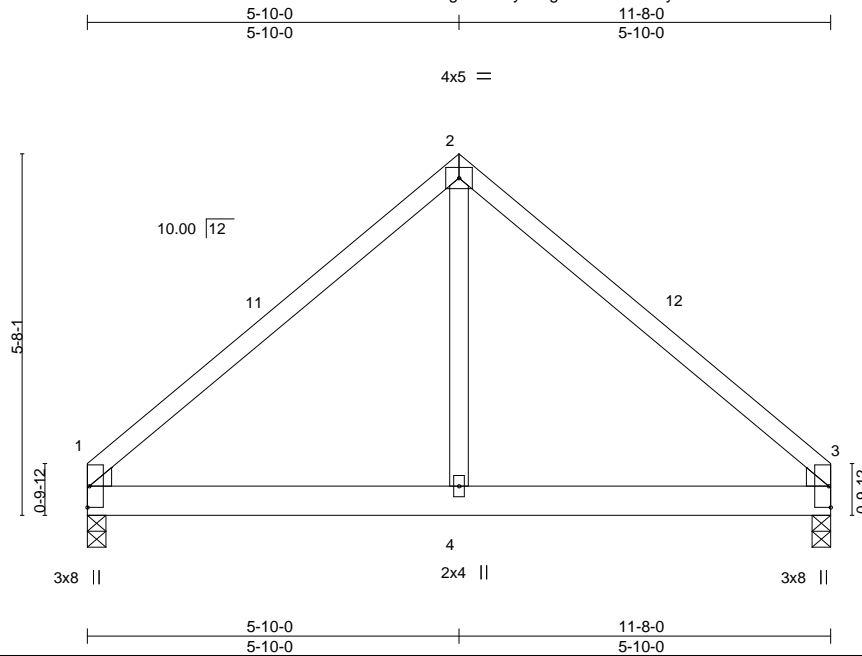

Scale = 1:36.2

Plate Offsets (X,Y)-- [1:0-0-2,0-0-3], [1:0-0-5,0-3-3], [3:0-0-2,0-0-3], [3:0-0-5,0-3-3]

LOADING (psf)	SPACING-	CSI.	DEFL.	in (loc)	l/defl	L/d	PLATES	GRIP
TCLL 20.0	Plate Grip DOL 1.00	TC 0.40	Vert(LL) -0.01	4-7	>999	240	MT20	244/190
TCDL 10.0	Lumber DOL 1.15	BC 0.22	Vert(CT) -0.02	4-7	>999	180		
BCLL 0.0 *	Rep Stress Incr NO	WB 0.05	Horz(CT) 0.01	1	n/a	n/a		
BCDL 10.0	Code IRC2015/TPI2014	Matrix-MS						
							Weight: 59 lb	FT = 20%

LUMBER-

TOP CHORD 2x4 SP No.2
 BOT CHORD 2x6 SP No.2
 WEBS 2x4 SP No.2
 WEDGE
 Left: 2x4 SP No.3, Right: 2x4 SP No.3

BRACING-

TOP CHORD Structural wood sheathing directly applied or 6-0-0 oc purlins.
 BOT CHORD Rigid ceiling directly applied or 10-0-0 oc bracing.

REACTIONS.

(size) 1=0-3-8, 3=0-3-8
 Max Horz 1=-88(LC 9)
 Max Uplift 1=-3(LC 11), 3=-3(LC 11)
 Max Grav 1=467(LC 1), 3=467(LC 1)

FORCES. (lb) - Max. Comp./Max. Ten. - All forces 250 (lb) or less except when shown.

TOP CHORD 1-2=-502/92, 2-3=-502/91
 BOT CHORD 1-4=0/300, 3-4=0/300

NOTES-

- Unbalanced roof live loads have been considered for this design.
- Wind: ASCE 7-10; Vult=120mph (3-second gust) Vasd=95mph; TCDL=6.0psf; BCDL=6.0psf; h=25ft; B=45ft; L=24ft; eave=4ft; Cat. II; Exp B; Enclosed; MWFRS (directional) and C-C Exterior(2) 0-0-0 to 3-0-0, Interior(1) 3-0-0 to 5-10-0, Exterior(2) 5-10-0 to 8-10-0, Interior(1) 8-10-0 to 11-8-0 zone; cantilever left and right exposed; end vertical left and right exposed; C-C for members and forces & MWFRS for reactions shown; Lumber DOL=1.60 plate grip DOL=1.60
- * This truss has been designed for a live load of 20.0psf on the bottom chord in all areas where a rectangle 3-6-0 tall by 2-0-0 wide will fit between the bottom chord and any other members.
- Provide mechanical connection (by others) of truss to bearing plate capable of withstanding 100 lb uplift at joint(s) 1, 3.

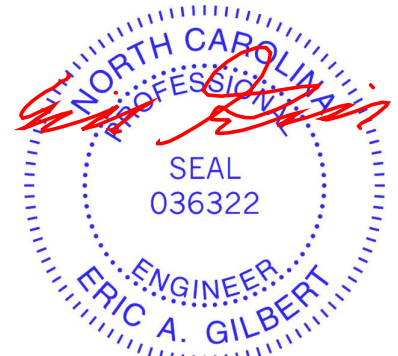

April 20,2020

WARNING - Verify design parameters and READ NOTES ON THIS AND INCLUDED MITEK REFERENCE PAGE MII-7473 rev. 10/03/2015 BEFORE USE.

Design valid for use only with MiTek® connectors. This design is based only upon parameters shown, and is for an individual building component, not a truss system. Before use, the building designer must verify the applicability of design parameters and properly incorporate this design into the overall building design. Bracing indicated is to prevent buckling of individual truss web and/or chord members only. Additional temporary and permanent bracing is always required for stability and to prevent collapse with possible personal injury and property damage. For general guidance regarding the fabrication, storage, delivery, erection and bracing of trusses and truss systems, see **ANSI/TPI1 Quality Criteria, DSB-89 and BCSI Building Component Safety Information** available from Truss Plate Institute, 218 N. Lee Street, Suite 312, Alexandria, VA 22314.



818 Soundside Road
 Edenton, NC 27932

Job 200607RT1	Truss D02	Truss Type Common Supported Gable	Qty 1	Ply 1	FFH-WILSON PLAN 25 PLANTERS GLEN Job Reference (optional)	E14316820
------------------	--------------	--------------------------------------	----------	----------	--	-----------

Carolina Structural Systems, LLC, Ether, NC - 27247,

8.330 s Mar 23 2020 MiTek Industries, Inc. Mon Apr 20 14:38:17 2020 Page 1

ID:ng1sARatyWRgmLmP2hZLLXyQUhk-mHzjM4o4KjOlxWtQz3SpDQd99yTpLoStBtuR5EzOoDK

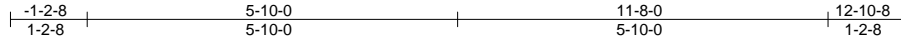

3x4 =

Scale = 1:36.3

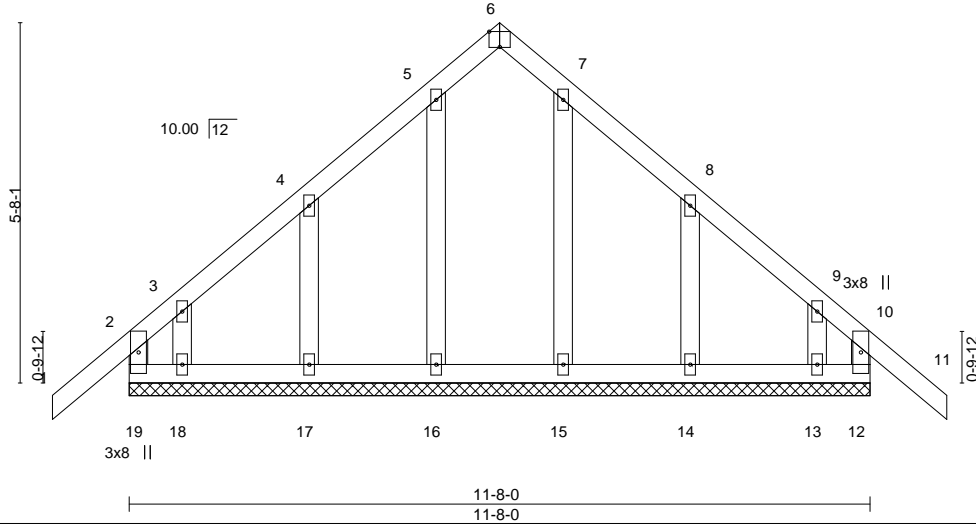

Plate Offsets (X,Y)-- [6:0-2-0,Edge]

LOADING (psf)	SPACING-	CSI.	DEFL.	in (loc)	l/defl	L/d	PLATES	GRIP
TCLL 20.0	Plate Grip DOL 1.00	TC 0.13	Vert(LL) -0.01	11	n/r	120	MT20	244/190
TCDL 10.0	Lumber DOL 1.15	BC 0.07	Vert(CT) -0.01	11	n/r	120		
BCLL 0.0 *	Rep Stress Incr YES	WB 0.04	Horz(CT) 0.00	12	n/a	n/a		
BCDL 10.0	Code IRC2015/TPI2014	Matrix-R					Weight: 70 lb	FT = 20%

LUMBER-
 TOP CHORD 2x4 SP No.2
 BOT CHORD 2x4 SP No.2
 WEBS 2x4 SP No.2
 OTHERS 2x4 SP No.2

BRACING-
 TOP CHORD Structural wood sheathing directly applied or 6-0-0 oc purlins, except end verticals.
 BOT CHORD Rigid ceiling directly applied or 10-0-0 oc bracing.

REACTIONS. All bearings 11-8-0.
 (lb) - Max Horz 19=-122(LC 9)
 Max Uplift All uplift 100 lb or less at joint(s) 19, 12, 17, 18, 14, 13
 Max Grav All reactions 250 lb or less at joint(s) 19, 12, 16, 17, 18, 15, 14, 13

FORCES. (lb) - Max. Comp./Max. Ten. - All forces 250 (lb) or less except when shown.

NOTES-

- Unbalanced roof live loads have been considered for this design.
- Wind: ASCE 7-10; Vult=120mph (3-second gust) Vasd=95mph; TCCL=6.0psf; BCDL=6.0psf; h=25ft; B=45ft; L=24ft; eave=2ft; Cat. II; Exp B; Enclosed; MWFRS (directional) and C-C Corner(3) -1-2-8 to 1-9-8, Exterior(2) 1-9-8 to 5-10-0, Corner(3) 5-10-0 to 8-10-0, Exterior(2) 8-10-0 to 12-10-8 zone; cantilever left and right exposed; end vertical left and right exposed; C-C for members and forces & MWFRS for reactions shown; Lumber DOL=1.60 plate grip DOL=1.60
- Truss designed for wind loads in the plane of the truss only. For studs exposed to wind (normal to the face), see Standard Industry Gable End Details as applicable, or consult qualified building designer as per ANSI/TPI 1.
- All plates are 2x4 MT20 unless otherwise indicated.
- Gable requires continuous bottom chord bearing.
- Truss to be fully sheathed from one face or securely braced against lateral movement (i.e. diagonal web).
- Gable studs spaced at 2-0-0 oc.
- * This truss has been designed for a live load of 20.0psf on the bottom chord in all areas where a rectangle 3-6-0 tall by 2-0-0 wide will fit between the bottom chord and any other members.
- Provide mechanical connection (by others) of truss to bearing plate capable of withstanding 100 lb uplift at joint(s) 19, 12, 17, 18, 14, 13.

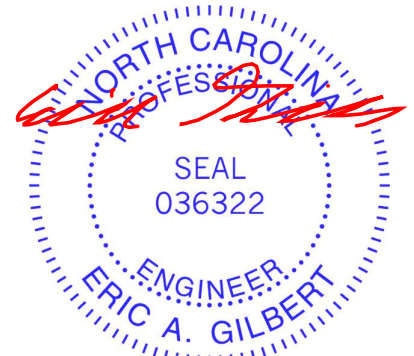

April 20,2020

WARNING - Verify design parameters and READ NOTES ON THIS AND INCLUDED MITEK REFERENCE PAGE MII-7473 rev. 10/03/2015 BEFORE USE.

Design valid for use only with MiTek® connectors. This design is based only upon parameters shown, and is for an individual building component, not a truss system. Before use, the building designer must verify the applicability of design parameters and properly incorporate this design into the overall building design. Bracing indicated is to prevent buckling of individual truss web and/or chord members only. Additional temporary and permanent bracing is always required for stability and to prevent collapse with possible personal injury and property damage. For general guidance regarding the fabrication, storage, delivery, erection and bracing of trusses and truss systems, see **ANSI/TPI1 Quality Criteria, DSB-89 and BCSI Building Component Safety Information** available from Truss Plate Institute, 218 N. Lee Street, Suite 312, Alexandria, VA 22314.



818 Soundside Road
 Edenton, NC 27932

Job 200607RT1	Truss E01	Truss Type Common	Qty 2	Ply 1	FFH-WILSON PLAN 25 PLANTERS GLEN	E14316821
------------------	--------------	----------------------	----------	----------	----------------------------------	-----------

Carolina Structural Systems, LLC, Ether, NC - 27247,

8.330 s Mar 23 2020 MiTek Industries, Inc. Mon Apr 20 14:38:18 2020 Page 1
ID:ng1sARatyWRgmLmP2hZLLXyQUhk-ETW5ZQpi51XcYgScWmz2ldAF9Mj64FZ1QXe_dgzOoDJ

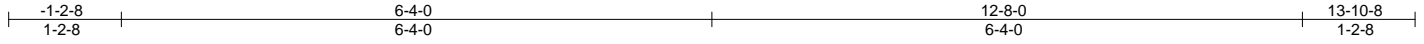

Scale = 1:24.7

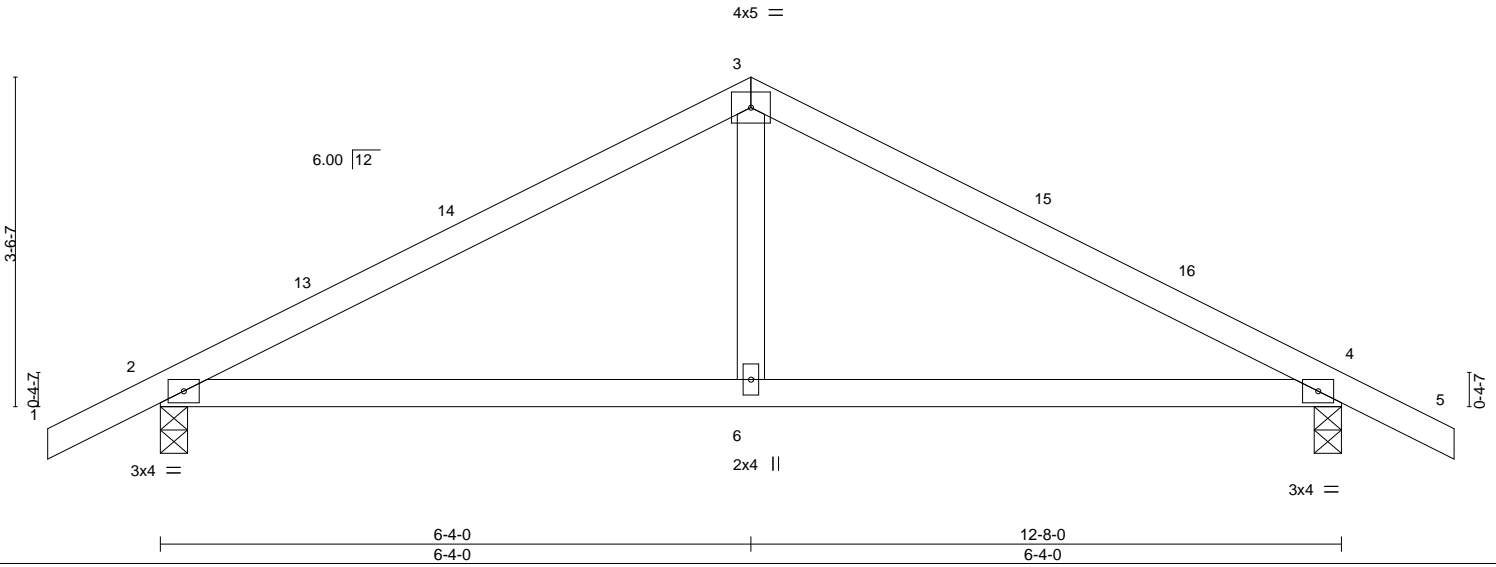

LOADING (psf)	SPACING-	CSI.	DEFL.	PLATES	GRIP
TCLL 20.0	2-0-0	TC 0.50	in (loc) l/defl L/d	MT20	244/190
TCDL 10.0	Plate Grip DOL 1.00	BC 0.45	Vert(LL) -0.05 6-9 >999 240		
BCLL 0.0 *	Lumber DOL 1.15	WB 0.05	Vert(CT) -0.10 6-9 >999 180		
BCDL 10.0	Rep Stress Incr YES	Matrix-MS	Horz(CT) 0.01 4 n/a n/a		
	Code IRC2015/TPI2014			Weight: 49 lb	FT = 20%

LUMBER-

TOP CHORD 2x4 SP No.2
BOT CHORD 2x4 SP No.2
WEBS 2x4 SP No.2

BRACING-

TOP CHORD Structural wood sheathing directly applied or 6-0-0 oc purlins.
BOT CHORD Rigid ceiling directly applied or 10-0-0 oc bracing.

REACTIONS.

(size) 2=0-3-8, 4=0-3-8
Max Horz 2=-53(LC 9)
Max Uplift 2=-34(LC 11), 4=-34(LC 11)
Max Grav 2=579(LC 1), 4=579(LC 1)

FORCES. (lb) - Max. Comp./Max. Ten. - All forces 250 (lb) or less except when shown.

TOP CHORD 2-3=-707/86, 3-4=-707/86
BOT CHORD 2-6=0/566, 4-6=0/566

NOTES-

- Unbalanced roof live loads have been considered for this design.
- Wind: ASCE 7-10; Vult=120mph (3-second gust) Vasd=95mph; TCDD=6.0psf; BCDL=6.0psf; h=25ft; B=45ft; L=24ft; eave=4ft; Cat. II; Exp B; Enclosed; MWFRS (directional) and C-C Exterior(2) -1-2-8 to 1-9-8, Interior(1) 1-9-8 to 6-4-0, Exterior(2) 6-4-0 to 9-4-0, Interior(1) 9-4-0 to 13-10-8 zone; cantilever left and right exposed; end vertical left and right exposed; C-C for members and forces & MWFRS for reactions shown; Lumber DOL=1.60 plate grip DOL=1.60
- * This truss has been designed for a live load of 20.0psf on the bottom chord in all areas where a rectangle 3-6-0 tall by 2-0-0 wide will fit between the bottom chord and any other members.
- Provide mechanical connection (by others) of truss to bearing plate capable of withstanding 100 lb uplift at joint(s) 2, 4.

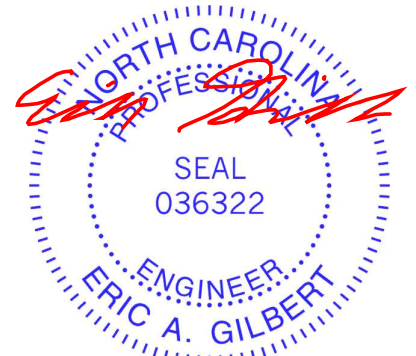

April 20,2020

WARNING - Verify design parameters and READ NOTES ON THIS AND INCLUDED MITEK REFERENCE PAGE MII-7473 rev. 10/03/2015 BEFORE USE.

Design valid for use only with MiTek® connectors. This design is based only upon parameters shown, and is for an individual building component, not a truss system. Before use, the building designer must verify the applicability of design parameters and properly incorporate this design into the overall building design. Bracing indicated is to prevent buckling of individual truss web and/or chord members only. Additional temporary and permanent bracing is always required for stability and to prevent collapse with possible personal injury and property damage. For general guidance regarding the fabrication, storage, delivery, erection and bracing of trusses and truss systems, see **ANSI/TPI1 Quality Criteria, DSB-89 and BCSI Building Component Safety Information** available from Truss Plate Institute, 218 N. Lee Street, Suite 312, Alexandria, VA 22314.



818 Soundside Road
Edenton, NC 27932

Job 200607RT1	Truss E02	Truss Type Common Supported Gable	Qty 1	Ply 1	FFH-WILSON PLAN 25 PLANTERS GLEN Job Reference (optional)	E14316822
------------------	--------------	--------------------------------------	----------	----------	--	-----------

Carolina Structural Systems, LLC, Ether, NC - 27247,

8,330 s Mar 23 2020 MiTek Industries, Inc. Mon Apr 20 14:38:19 2020 Page 1
ID:ng1sARatyWRgmLmP2hZLLXyQUhk-if4UnmplrKfTAq1o4UUHlrjW5mATpiBAfBNY96zOoDI

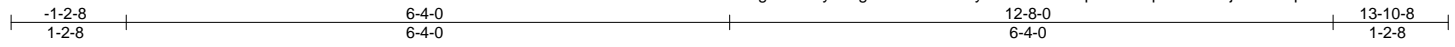

Scale: 1/2"=1'

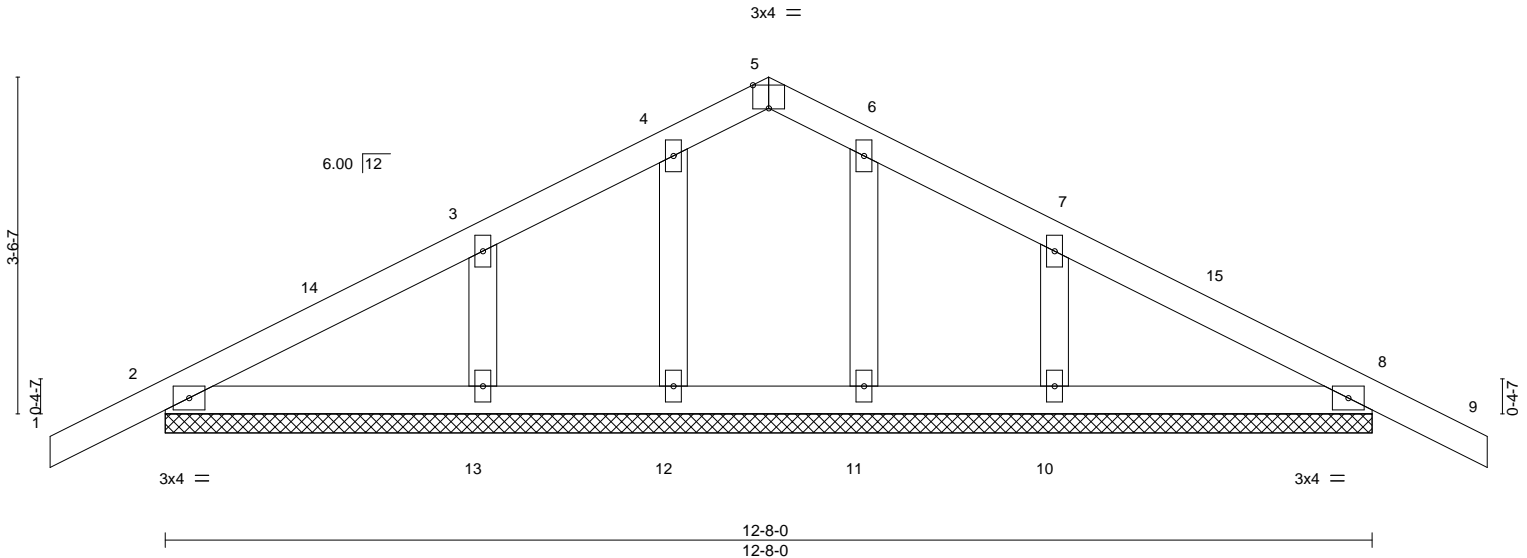

LOADING (psf)	SPACING-	CSI.	DEFL.	in (loc)	l/defl	L/d	PLATES	GRIP
TCLL 20.0	Plate Grip DOL 1.00	TC 0.10	Vert(LL) 0.00	8	n/r	120	MT20	244/190
TCDL 10.0	Lumber DOL 1.15	BC 0.06	Vert(CT) 0.00	9	n/r	120		
BCLL 0.0 *	Rep Stress Incr YES	WB 0.03	Horz(CT) 0.00	8	n/a	n/a		
BCDL 10.0	Code IRC2015/TPI2014	Matrix-S						
							Weight: 56 lb	FT = 20%

LUMBER-
TOP CHORD 2x4 SP No.2
BOT CHORD 2x4 SP No.2
OTHERS 2x4 SP No.2

BRACING-
TOP CHORD Structural wood sheathing directly applied or 6-0-0 oc purlins.
BOT CHORD Rigid ceiling directly applied or 10-0-0 oc bracing.

REACTIONS. All bearings 12-8-0.
(lb) - Max Horz 2=53(LC 10)
Max Uplift All uplift 100 lb or less at joint(s) 2, 8, 13, 10
Max Grav All reactions 250 lb or less at joint(s) 2, 8, 12, 13, 11, 10

FORCES. (lb) - Max. Comp./Max. Ten. - All forces 250 (lb) or less except when shown.

- NOTES-**
- Unbalanced roof live loads have been considered for this design.
 - Wind: ASCE 7-10; Vult=120mph (3-second gust) Vasd=95mph; TCCL=6.0psf; BCDL=6.0psf; h=25ft; B=45ft; L=24ft; eave=2ft; Cat. II; Exp B; Enclosed; MWFRS (directional) and C-C Corner(3) 1-2-8 to 1-9-8, Exterior(2) 1-9-8 to 6-4-0, Corner(3) 6-4-0 to 9-4-0, Exterior(2) 9-4-0 to 13-10-8 zone; cantilever left and right exposed; end vertical left and right exposed; C-C for members and forces & MWFRS for reactions shown; Lumber DOL=1.60 plate grip DOL=1.60
 - Truss designed for wind loads in the plane of the truss only. For studs exposed to wind (normal to the face), see Standard Industry Gable End Details as applicable, or consult qualified building designer as per ANSI/TPI 1.
 - All plates are 2x4 MT20 unless otherwise indicated.
 - Gable requires continuous bottom chord bearing.
 - Gable studs spaced at 2-0-0 oc.
 - * This truss has been designed for a live load of 20.0psf on the bottom chord in all areas where a rectangle 3-6-0 tall by 2-0-0 wide will fit between the bottom chord and any other members.
 - Provide mechanical connection (by others) of truss to bearing plate capable of withstanding 100 lb uplift at joint(s) 2, 8, 13, 10.

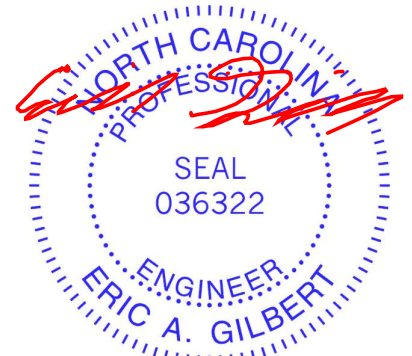
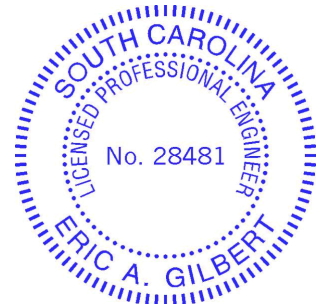

April 20, 2020

WARNING - Verify design parameters and READ NOTES ON THIS AND INCLUDED MITEK REFERENCE PAGE MII-7473 rev. 10/03/2015 BEFORE USE.
Design valid for use only with MiTek® connectors. This design is based only upon parameters shown, and is for an individual building component, not a truss system. Before use, the building designer must verify the applicability of design parameters and properly incorporate this design into the overall building design. Bracing indicated is to prevent buckling of individual truss web and/or chord members only. Additional temporary and permanent bracing is always required for stability and to prevent collapse with possible personal injury and property damage. For general guidance regarding the fabrication, storage, delivery, erection and bracing of trusses and truss systems, see **ANSI/TPI1 Quality Criteria, DSB-89 and BCSI Building Component Safety Information** available from Truss Plate Institute, 218 N. Lee Street, Suite 312, Alexandria, VA 22314.



818 Soundside Road
Edenton, NC 27932

Job 200607RT1	Truss E03	Truss Type Common Girder	Qty 1	Ply 2	FFH-WILSON PLAN 25 PLANTERS GLEN Job Reference (optional)	E14316823
------------------	--------------	-----------------------------	----------	----------	--	-----------

Carolina Structural Systems, LLC, Ether, NC - 27247,

8.330 s Mar 23 2020 MiTek Industries, Inc. Mon Apr 20 14:38:20 2020 Page 1
ID:ng1sARatyWRgmLmP2hZLLXyQUhk-Ases_6qzcenKozc_eB0Wr2FXLAMXY2EKtr75iYzOoDH

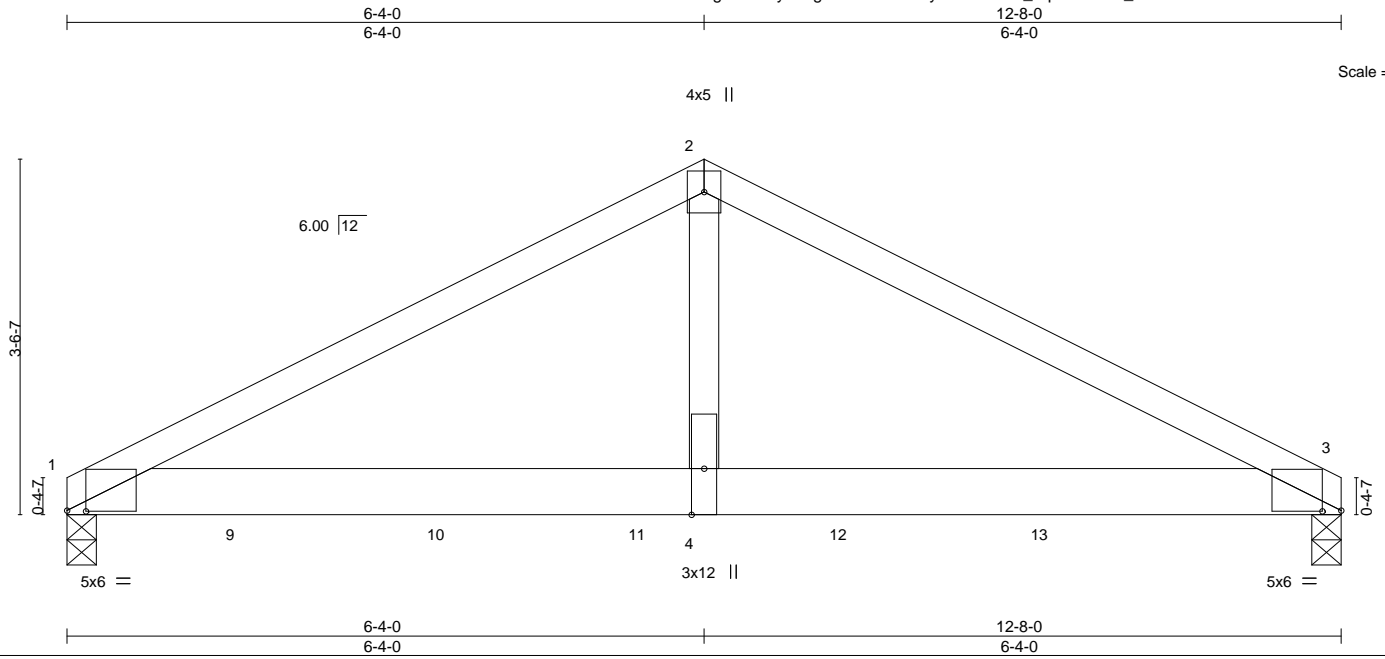

Plate Offsets (X,Y)-- [1:0-2-4,0-0-1], [3:0-2-4,0-0-1]					
LOADING (psf)	SPACING- 2-0-0	CSI.	DEFL. in (loc) l/defl L/d	PLATES	GRIP
TCLL 20.0	Plate Grip DOL 1.00	TC 0.71	Vert(LL) -0.08 4-8 >999 240	MT20	244/190
TCDL 10.0	Lumber DOL 1.15	BC 0.64	Vert(CT) -0.17 4-8 >910 180		
BCLL 0.0 *	Rep Stress Incr NO	WB 0.49	Horz(CT) 0.03 3 n/a n/a		
BCDL 10.0	Code IRC2015/TPI2014	Matrix-MS			
				Weight: 110 lb	FT = 20%

LUMBER-	BRACING-
TOP CHORD 2x4 SP No.2	TOP CHORD Structural wood sheathing directly applied or 4-5-11 oc purlins.
BOT CHORD 2x6 SP DSS	BOT CHORD Rigid ceiling directly applied or 10-0-0 oc bracing.
WEBS 2x4 SP No.2	

REACTIONS. (size) 1=0-3-8, 3=0-3-8
Max Horz 1=45(LC 6)
Max Grav 1=3221(LC 1), 3=3669(LC 1)

FORCES. (lb) - Max. Comp./Max. Ten. - All forces 250 (lb) or less except when shown.
TOP CHORD 1-2=-4958/0, 2-3=-4956/0
BOT CHORD 1-4=0/4404, 3-4=0/4404
WEBS 2-4=0/3968

- NOTES-**
- 2-ply truss to be connected together with 10d (0.131"x3") nails as follows:
Top chords connected as follows: 2x4 - 1 row at 0-9-0 oc.
Bottom chords connected as follows: 2x6 - 2 rows staggered at 0-9-0 oc.
Webs connected as follows: 2x4 - 1 row at 0-9-0 oc.
 - All loads are considered equally applied to all plies, except if noted as front (F) or back (B) face in the LOAD CASE(S) section. Ply to ply connections have been provided to distribute only loads noted as (F) or (B), unless otherwise indicated.
 - Unbalanced roof live loads have been considered for this design.
 - Wind: ASCE 7-10; Vult=120mph (3-second gust) Vasd=95mph; TCCL=6.0psf; BCDL=6.0psf; h=25ft; B=45ft; L=24ft; eave=4ft; Cat. II; Exp B; Enclosed; MWFRS (directional); cantilever left and right exposed ; end vertical left and right exposed; Lumber DOL=1.60 plate grip DOL=1.60
 - * This truss has been designed for a live load of 20.0psf on the bottom chord in all areas where a rectangle 3-6-0 tall by 2-0-0 wide will fit between the bottom chord and any other members.
 - Hanger(s) or other connection device(s) shall be provided sufficient to support concentrated load(s) 961 lb down and 27 lb up at 1-9-4, 994 lb down at 3-9-4, 994 lb down at 5-9-4, 994 lb down at 7-9-4, and 994 lb down at 9-9-4, and 995 lb down at 11-9-4 on bottom chord. The design/selection of such connection device(s) is the responsibility of others.

LOAD CASE(S) Standard

- Dead + Roof Live (balanced): Lumber Increase=1.15, Plate Increase=1.00

Uniform Loads (plf)
Vert: 1-2=-60, 2-3=-60, 1-3=-20

Concentrated Loads (lb)
Vert: 8=-987(F) 9=-947(F) 10=-986(F) 11=-986(F) 12=-986(F) 13=-986(F)

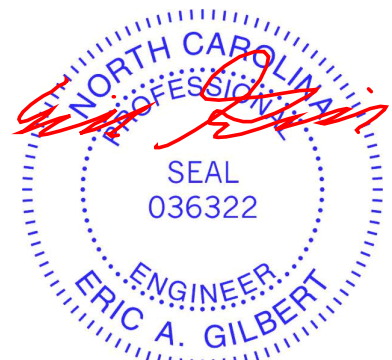

April 20,2020

Job 200607RT1	Truss V01	Truss Type Valley	Qty 1	Ply 1	FFH-WILSON PLAN 25 PLANTERS GLEN Job Reference (optional)	E14316824
------------------	--------------	----------------------	----------	----------	--	-----------

Carolina Structural Systems, LLC, Ether, NC - 27247,

8.330 s Mar 23 2020 MiTek Industries, Inc. Mon Apr 20 14:38:20 2020 Page 1

ID:ng1sARatyWRgmLmP2hZLLXyQUhk-Ases_6qzcenKozc_eB0Wr2Fi8AWwY9qKtr75iYzOoDH

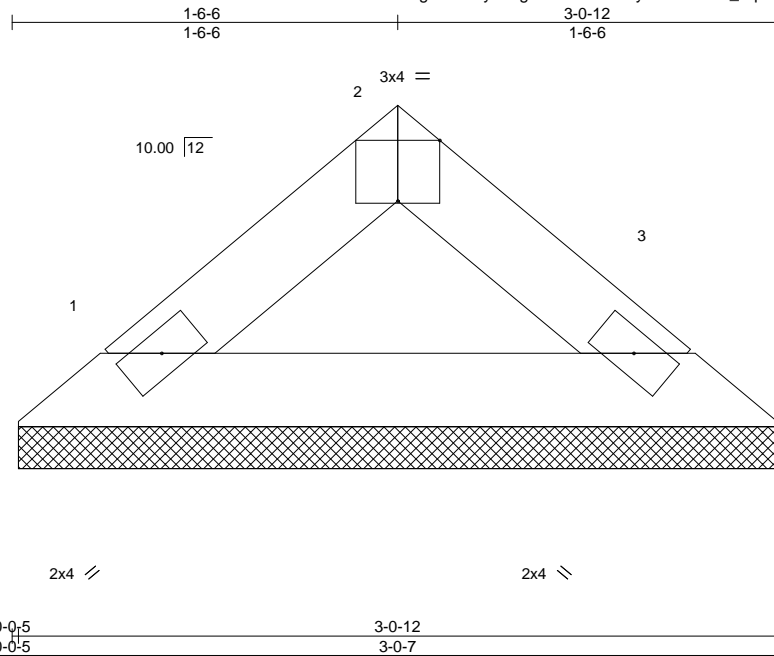

Scale = 1:9.2

Plate Offsets (X,Y)--		[2:0-2-0,Edge]								
LOADING (psf)	SPACING-	2-0-0	CSI.	DEFL.	in (loc)	l/defl	L/d	PLATES	GRIP	
TCLL 20.0	Plate Grip DOL	1.00	TC 0.02	Vert(LL)	n/a	-	n/a	999	MT20	244/190
TCDL 10.0	Lumber DOL	1.15	BC 0.04	Vert(CT)	n/a	-	n/a	999		
BCLL 0.0 *	Rep Stress Incr	YES	WB 0.00	Horz(CT)	0.00	3	n/a	n/a		
BCDL 10.0	Code	IRC2015/TPI2014	Matrix-P						Weight: 9 lb	FT = 20%

LUMBER-
TOP CHORD 2x4 SP No.2
BOT CHORD 2x4 SP No.2

BRACING-
TOP CHORD Structural wood sheathing directly applied or 3-0-12 oc purlins.
BOT CHORD Rigid ceiling directly applied or 10-0-0 oc bracing.

REACTIONS. (size) 1=3-0-3, 3=3-0-3
Max Horz 1=-17(LC 9)
Max Uplift 1=-1(LC 11), 3=-1(LC 11)
Max Grav 1=90(LC 1), 3=90(LC 1)

FORCES. (lb) - Max. Comp./Max. Ten. - All forces 250 (lb) or less except when shown.

NOTES-

- Unbalanced roof live loads have been considered for this design.
- Wind: ASCE 7-10; Vult=120mph (3-second gust) Vasd=95mph; TCDL=6.0psf; BCDL=6.0psf; h=25ft; B=45ft; L=24ft; eave=4ft; Cat. II; Exp B; Enclosed; MWFRS (directional) and C-C Exterior(2) zone; cantilever left and right exposed; end vertical left and right exposed; C-C for members and forces & MWFRS for reactions shown; Lumber DOL=1.60 plate grip DOL=1.60
- Gable requires continuous bottom chord bearing.
- * This truss has been designed for a live load of 20.0psf on the bottom chord in all areas where a rectangle 3-6-0 tall by 2-0-0 wide will fit between the bottom chord and any other members.
- Provide mechanical connection (by others) of truss to bearing plate capable of withstanding 100 lb uplift at joint(s) 1, 3.

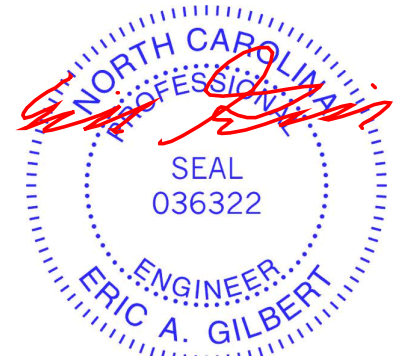

April 20,2020

WARNING - Verify design parameters and READ NOTES ON THIS AND INCLUDED MITEK REFERENCE PAGE MII-7473 rev. 10/03/2015 BEFORE USE.

Design valid for use only with MiTek® connectors. This design is based only upon parameters shown, and is for an individual building component, not a truss system. Before use, the building designer must verify the applicability of design parameters and properly incorporate this design into the overall building design. Bracing indicated is to prevent buckling of individual truss web and/or chord members only. Additional temporary and permanent bracing is always required for stability and to prevent collapse with possible personal injury and property damage. For additional guidance regarding the fabrication, storage, delivery, erection and bracing of trusses and truss systems, see **ANSI/TPI1 Quality Criteria, DSB-89 and BCSI Building Component Safety Information** available from Truss Plate Institute, 218 N. Lee Street, Suite 312, Alexandria, VA 22314.

ENGINEERING BY
TRENCO
A MiTek Affiliate

818 Soundside Road
Edenton, NC 27932

Job 200607RT1	Truss V02	Truss Type Valley	Qty 1	Ply 1	FFH-WILSON PLAN 25 PLANTERS GLEN Job Reference (optional)	E14316825
------------------	--------------	----------------------	----------	----------	--	-----------

Carolina Structural Systems, LLC, Ether, NC - 27247,

8.330 s Mar 23 2020 MiTek Industries, Inc. Mon Apr 20 14:38:21 2020 Page 1
ID:ng1sARatyWRgmLmp2hZLLXyQUhk-e2CEBSrbNybBP7BBCvXINGoqAZr0HcrT6VseE?zOoDG

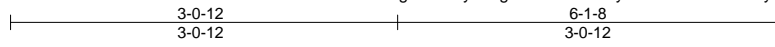

Scale = 1:18.2

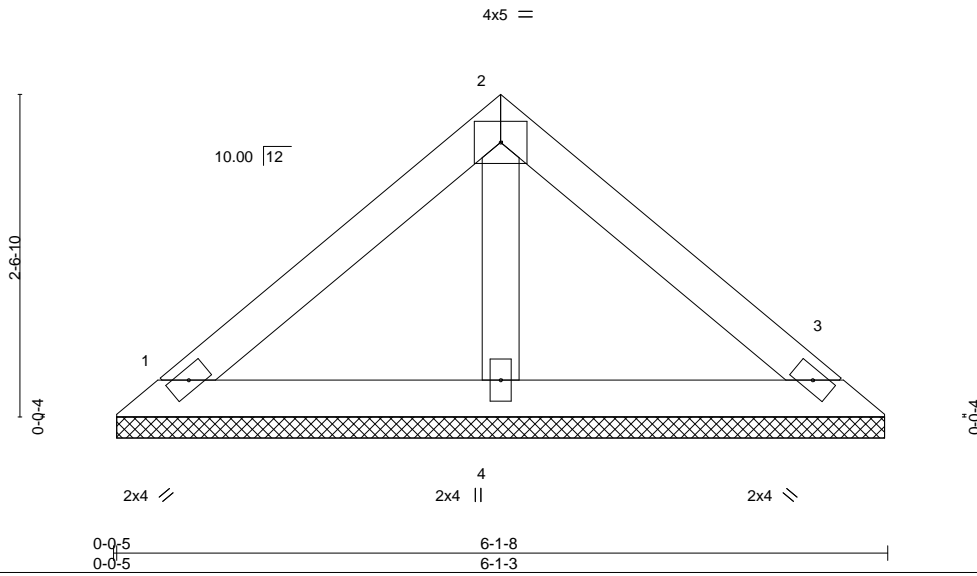

LOADING (psf)	SPACING-	CSI.	DEFL.	in (loc)	l/defl	L/d	PLATES	GRIP
TCLL 20.0	Plate Grip DOL 1.00	TC 0.13	Vert(LL) n/a	-	n/a	999	MT20	244/190
TCDL 10.0	Lumber DOL 1.15	BC 0.05	Vert(CT) n/a	-	n/a	999		
BCLL 0.0 *	Rep Stress Incr YES	WB 0.02	Horz(CT) 0.00	3	n/a	n/a		
BCDL 10.0	Code IRC2015/TPI2014	Matrix-P					Weight: 22 lb	FT = 20%

LUMBER-
TOP CHORD 2x4 SP No.2
BOT CHORD 2x4 SP No.2
OTHERS 2x4 SP No.2

BRACING-
TOP CHORD Structural wood sheathing directly applied or 6-0-0 oc purlins.
BOT CHORD Rigid ceiling directly applied or 10-0-0 oc bracing.

REACTIONS. (size) 1=6-0-14, 3=6-0-14, 4=6-0-14
Max Horz 1=40(LC 9)
Max Uplift 1=14(LC 11), 3=14(LC 11)
Max Grav 1=121(LC 1), 3=121(LC 1), 4=184(LC 1)

FORCES. (lb) - Max. Comp./Max. Ten. - All forces 250 (lb) or less except when shown.

NOTES-

- Unbalanced roof live loads have been considered for this design.
- Wind: ASCE 7-10; Vult=120mph (3-second gust) Vasd=95mph; TC DL=6.0psf; BCDL=6.0psf; h=25ft; B=45ft; L=24ft; eave=4ft; Cat. II; Exp B; Enclosed; MWFRS (directional) and C-C Exterior(2) zone; cantilever left and right exposed; end vertical left and right exposed; C-C for members and forces & MWFRS for reactions shown; Lumber DOL=1.60 plate grip DOL=1.60
- Gable requires continuous bottom chord bearing.
- * This truss has been designed for a live load of 20.0psf on the bottom chord in all areas where a rectangle 3-6-0 tall by 2-0-0 wide will fit between the bottom chord and any other members.
- Provide mechanical connection (by others) of truss to bearing plate capable of withstanding 100 lb uplift at joint(s) 1, 3.

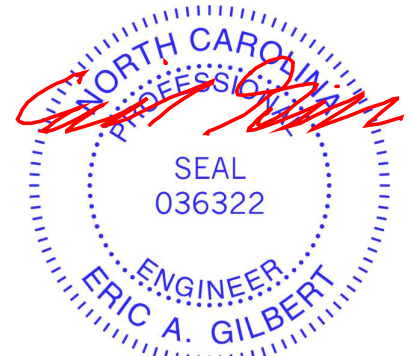

April 20, 2020

WARNING - Verify design parameters and READ NOTES ON THIS AND INCLUDED MITEK REFERENCE PAGE MII-7473 rev. 10/03/2015 BEFORE USE.

Design valid for use only with MiTek® connectors. This design is based only upon parameters shown, and is for an individual building component, not a truss system. Before use, the building designer must verify the applicability of design parameters and properly incorporate this design into the overall building design. Bracing indicated is to prevent buckling of individual truss web and/or chord members only. Additional temporary and permanent bracing is always required for stability and to prevent collapse with possible personal injury and property damage. For general guidance regarding the fabrication, storage, delivery, erection and bracing of trusses and truss systems, see **ANSI/TPI1 Quality Criteria, DSB-89 and BCSI Building Component Safety Information** available from Truss Plate Institute, 218 N. Lee Street, Suite 312, Alexandria, VA 22314.



818 Soundside Road
Edenton, NC 27932

Job 200607RT1	Truss V03	Truss Type Valley	Qty 1	Ply 1	FFH-WILSON PLAN 25 PLANTERS GLEN Job Reference (optional)	E14316826
------------------	--------------	----------------------	----------	----------	--	-----------

Carolina Structural Systems, LLC, Ether, NC - 27247,

8.330 s Mar 23 2020 MiTek Industries, Inc. Mon Apr 20 14:38:22 2020 Page 1
ID:ng1sARatyWRgmLmP2hZLLXyQUhk-6EmcPnsD8F121HmNlc2_wTL_5z9x03fcl9cCmRzOoDF

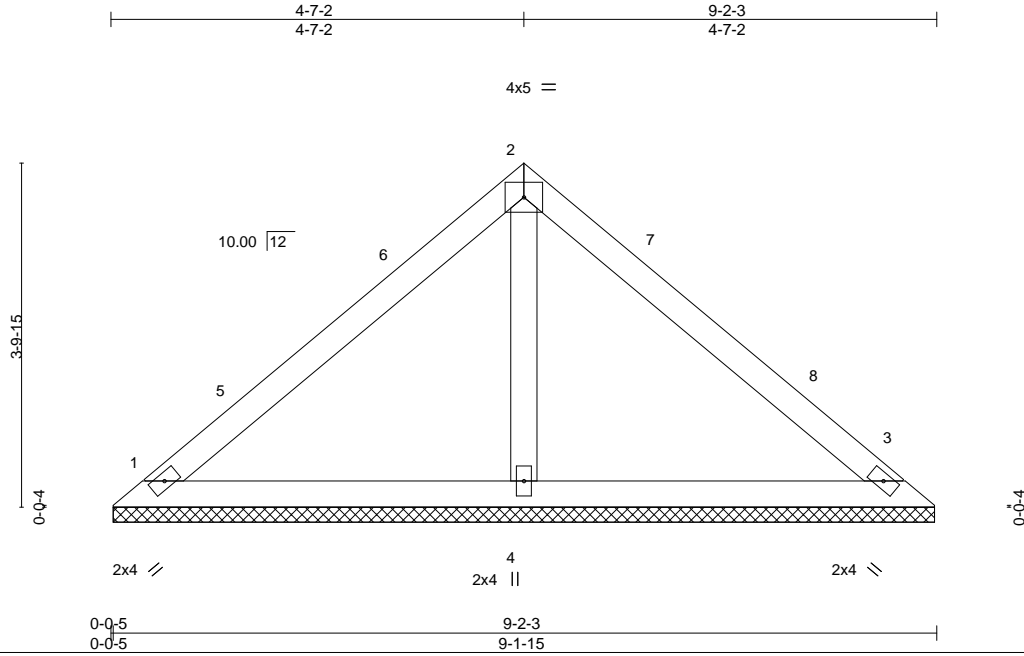

Scale = 1:25.6

LOADING (psf)	SPACING-	CSI.	DEFL.	PLATES	GRIP
TCLL 20.0	2-0-0	TC 0.25	in (loc) l/defl L/d	MT20	244/190
TCDL 10.0	Plate Grip DOL 1.00	BC 0.14	Vert(LL) n/a - n/a 999		
BCLL 0.0 *	Lumber DOL 1.15	WB 0.04	Vert(CT) n/a - n/a 999		
BCDL 10.0	Rep Stress Incr YES	Matrix-S	Horz(CT) 0.00 3 n/a n/a	Weight: 35 lb	FT = 20%
	Code IRC2015/TPI2014				

LUMBER-

TOP CHORD 2x4 SP No.2
BOT CHORD 2x4 SP No.2
OTHERS 2x4 SP No.2

BRACING-

TOP CHORD Structural wood sheathing directly applied or 6-0-0 oc purlins.
BOT CHORD Rigid ceiling directly applied or 10-0-0 oc bracing.

REACTIONS.

(size) 1=9-1-10, 3=9-1-10, 4=9-1-10
Max Horz 1=63(LC 10)
Max Uplift 1=-14(LC 11), 3=-14(LC 11)
Max Grav 1=175(LC 1), 3=175(LC 1), 4=319(LC 1)

FORCES. (lb) - Max. Comp./Max. Ten. - All forces 250 (lb) or less except when shown.

NOTES-

- Unbalanced roof live loads have been considered for this design.
- Wind: ASCE 7-10; Vult=120mph (3-second gust) Vasd=95mph; TCCL=6.0psf; BCDL=6.0psf; h=25ft; B=45ft; L=24ft; eave=4ft; Cat. II; Exp B; Enclosed; MWFRS (directional) and C-C Exterior(2) 0-4-13 to 3-4-13, Interior(1) 3-4-13 to 4-7-2, Exterior(2) 4-7-2 to 7-7-2, Interior(1) 7-7-2 to 8-9-6 zone; cantilever left and right exposed; end vertical left and right exposed; C-C for members and forces & MWFRS for reactions shown; Lumber DOL=1.60 plate grip DOL=1.60
- Gable requires continuous bottom chord bearing.
- * This truss has been designed for a live load of 20.0psf on the bottom chord in all areas where a rectangle 3-6-0 tall by 2-0-0 wide will fit between the bottom chord and any other members.
- Provide mechanical connection (by others) of truss to bearing plate capable of withstanding 100 lb uplift at joint(s) 1, 3.

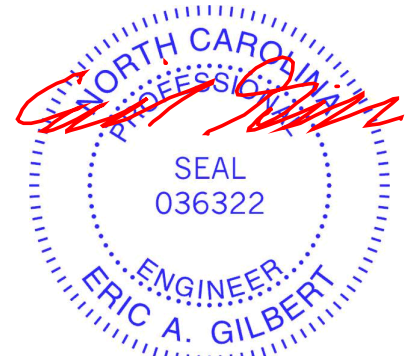

April 20,2020

WARNING - Verify design parameters and READ NOTES ON THIS AND INCLUDED MITEK REFERENCE PAGE MII-7473 rev. 10/03/2015 BEFORE USE.

Design valid for use only with MiTek® connectors. This design is based only upon parameters shown, and is for an individual building component, not a truss system. Before use, the building designer must verify the applicability of design parameters and properly incorporate this design into the overall building design. Bracing indicated is to prevent buckling of individual truss web and/or chord members only. Additional temporary and permanent bracing is always required for stability and to prevent collapse with possible personal injury and property damage. For general guidance regarding the fabrication, storage, delivery, erection and bracing of trusses and truss systems, see **ANSI/TPI1 Quality Criteria, DSB-89 and BCSI Building Component Safety Information** available from Truss Plate Institute, 218 N. Lee Street, Suite 312, Alexandria, VA 22314.



818 Soundside Road
Edenton, NC 27932

Job 200607RT1	Truss V04	Truss Type Valley	Qty 1	Ply 1	FFH-WILSON PLAN 25 PLANTERS GLEN Job Reference (optional)	E14316827
------------------	--------------	----------------------	----------	----------	--	-----------

Carolina Structural Systems, LLC, Ether, NC - 27247,

8.330 s Mar 23 2020 MiTek Industries, Inc. Mon Apr 20 14:38:23 2020 Page 1
ID:ng1sARatyWRgmLmp2hZLLXyQUhk-aRK_c7srvZ9ufRKZJKZDShtAKNXMIWImapLLJtzOoDE

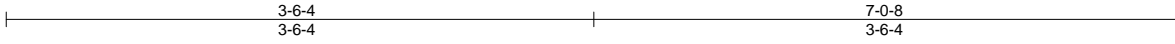

Scale = 1:13.8

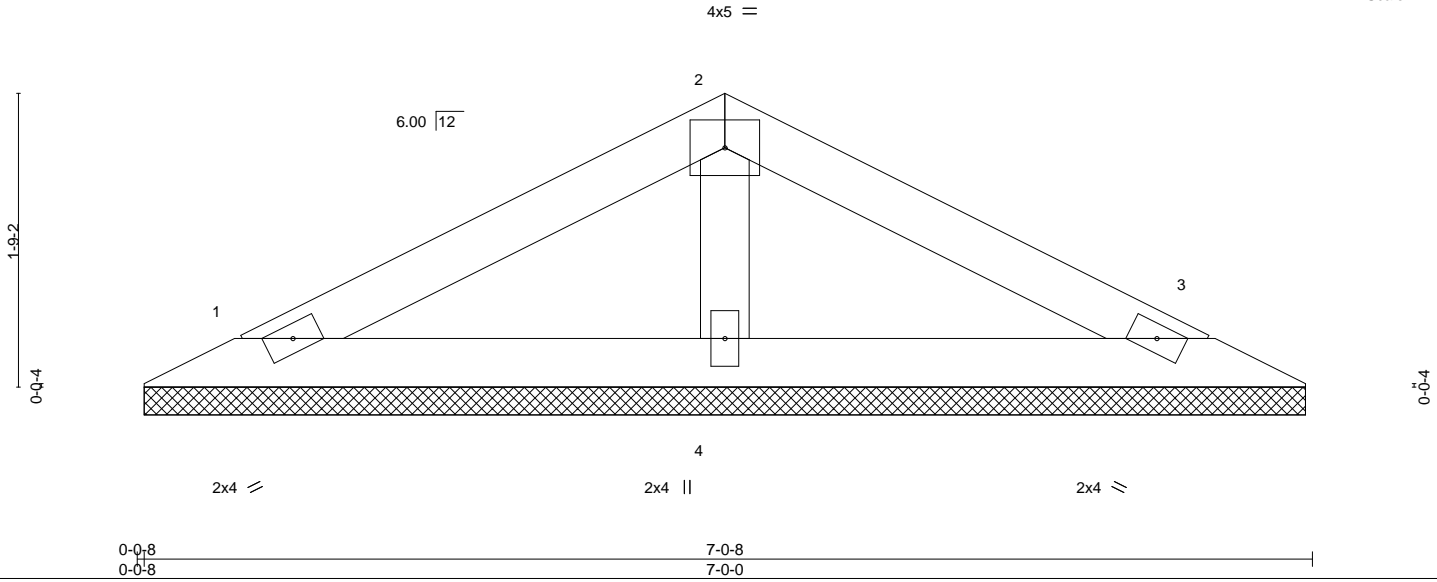

LOADING (psf)	SPACING-	CSL	DEFL.	in (loc)	l/defl	L/d	PLATES	GRIP
TCLL 20.0	Plate Grip DOL 1.00	TC 0.15	Vert(LL) n/a	-	n/a	999	MT20	244/190
TCDL 10.0	Lumber DOL 1.15	BC 0.06	Vert(CT) n/a	-	n/a	999		
BCLL 0.0 *	Rep Stress Incr YES	WB 0.02	Horz(CT) 0.00	3	n/a	n/a		
BCDL 10.0	Code IRC2015/TPI2014	Matrix-P					Weight: 22 lb	FT = 20%

LUMBER-
 TOP CHORD 2x4 SP No.2
 BOT CHORD 2x4 SP No.2
 OTHERS 2x4 SP No.2

BRACING-
 TOP CHORD Structural wood sheathing directly applied or 6-0-0 oc purlins.
 BOT CHORD Rigid ceiling directly applied or 10-0-0 oc bracing.

REACTIONS. (size) 1=6-11-8, 3=6-11-8, 4=6-11-8
 Max Horz 1=20(LC 10)
 Max Uplift 1=-10(LC 11), 3=-10(LC 11)
 Max Grav 1=117(LC 1), 3=117(LC 1), 4=229(LC 1)

FORCES. (lb) - Max. Comp./Max. Ten. - All forces 250 (lb) or less except when shown.

- NOTES-**
- Unbalanced roof live loads have been considered for this design.
 - Wind: ASCE 7-10; Vult=120mph (3-second gust) Vasd=95mph; TCCL=6.0psf; BCDL=6.0psf; h=25ft; B=45ft; L=24ft; eave=4ft; Cat. II; Exp B; Enclosed; MWFRS (directional) and C-C Exterior(2) zone; cantilever left and right exposed; end vertical left and right exposed; C-C for members and forces & MWFRS for reactions shown; Lumber DOL=1.60 plate grip DOL=1.60
 - Gable requires continuous bottom chord bearing.
 - * This truss has been designed for a live load of 20.0psf on the bottom chord in all areas where a rectangle 3-6-0 tall by 2-0-0 wide will fit between the bottom chord and any other members.
 - Provide mechanical connection (by others) of truss to bearing plate capable of withstanding 100 lb uplift at joint(s) 1, 3.



April 20, 2020

WARNING - Verify design parameters and READ NOTES ON THIS AND INCLUDED MITEK REFERENCE PAGE MII-7473 rev. 10/03/2015 BEFORE USE.

Design valid for use only with MiTek® connectors. This design is based only upon parameters shown, and is for an individual building component, not a truss system. Before use, the building designer must verify the applicability of design parameters and properly incorporate this design into the overall building design. Bracing indicated is to prevent buckling of individual truss web and/or chord members only. Additional temporary and permanent bracing is always required for stability and to prevent collapse with possible personal injury and property damage. For general guidance regarding the fabrication, storage, delivery, erection and bracing of trusses and truss systems, see **ANSI/TPI1 Quality Criteria, DSB-89 and BCSI Building Component Safety Information** available from Truss Plate Institute, 218 N. Lee Street, Suite 312, Alexandria, VA 22314.



818 Soundside Road
Edenton, NC 27932

Symbols

PLATE LOCATION AND ORIENTATION

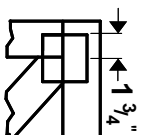

Center plate on joint unless x, y offsets are indicated. Dimensions are in ft-in-sixteenths. Apply plates to both sides of truss and fully embed teeth.

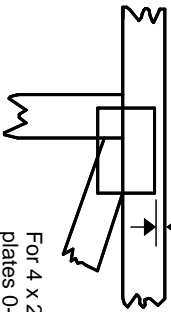

For 4 x 2 orientation, locate plates 0- 1/16" from outside edge of truss.



This symbol indicates the required direction of slots in connector plates.

* Plate location details available in **MITrak 20/20 software or upon request.**

PLATE SIZE

4 X 4

The first dimension is the plate width measured perpendicular to slots. Second dimension is the length parallel to slots.

LATERAL BRACING LOCATION



Indicated by symbol shown and/or by text in the bracing section of the output. Use T or I bracing if indicated.

BEARING



Indicates location where bearings (supports) occur. Icons vary but reaction section indicates joint number where bearings occur. Min size shown is for crushing only.

Industry Standards:

ANSI/TPI 1: National Design Specification for Metal Plate Connected Wood Truss Construction.
DSB-89: Design Standard for Bracing.
BCSI: Building Component Safety Information, Guide to Good Practice for Handling, Installing & Bracing of Metal Plate Connected Wood Trusses.

Numbering System

6-4-8
dimensions shown in ft-in-sixteenths
(Drawings not to scale)

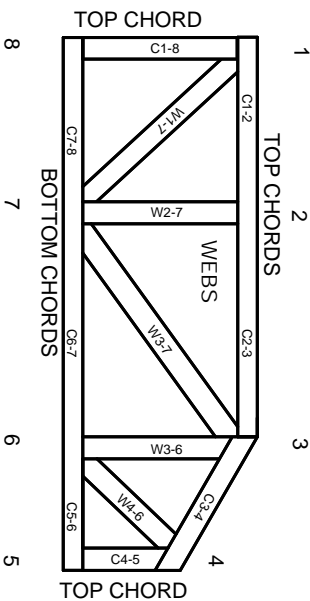

JOINTS ARE GENERALLY NUMBERED/LETTERED CLOCKWISE AROUND THE TRUSS STARTING AT THE JOINT FARTHEST TO THE LEFT.

CHORDS AND WEBS ARE IDENTIFIED BY END JOINT NUMBERS/LETTERS.

PRODUCT CODE APPROVALS

ICC-ES Reports:

ESR-1311, ESR-1352, ESR1988
ER-3907, ESR-2362, ESR-1397, ESR-3282

Trusses are designed for wind loads in the plane of the truss unless otherwise shown.

Lumber design values are in accordance with ANSI/TPI 1 section 6.3 These truss designs rely on lumber values established by others.

© 2012 MITTEK® All Rights Reserved



MITek Engineering Reference Sheet: MII-7473 rev. 10/03/2015



General Safety Notes

Failure to Follow Could Cause Property Damage or Personal Injury

1. Additional stability bracing for truss system, e.g. diagonal or X-bracing, is always required. See BCSI.
2. Truss bracing must be designed by an engineer. For wide truss spacing, individual lateral braces themselves may require bracing, or alternative Tor I bracing should be considered.
3. Never exceed the design loading shown and never stack materials on inadequately braced trusses.
4. Provide copies of this truss design to the building designer, erection supervisor, property owner and all other interested parties.
5. Cut members to bear tightly against each other.
6. Place plates on each face of truss at each joint and embed fully. Knots and wane at joint locations are regulated by ANSI/TPI 1.
7. Design assumes trusses will be suitably protected from the environment in accord with ANSI/TPI 1.
8. Unless otherwise noted, moisture content of lumber shall not exceed 19% at time of fabrication.
9. Unless expressly noted, this design is not applicable for use with fire retardant, preservative treated, or green lumber.
10. Camber is a non-structural consideration and is the responsibility of truss fabricator. General practice is to camber for dead load deflection.
11. Plate type, size, orientation and location dimensions indicated are minimum plating requirements.
12. Lumber used shall be of the species and size, and in all respects, equal to or better than that specified.
13. Top chords must be sheathed or purlins provided at spacing indicated on design.
14. Bottom chords require lateral bracing at 10 ft. spacing, or less, if no ceiling is installed, unless otherwise noted.
15. Connections not shown are the responsibility of others.
16. Do not cut or alter truss member or plate without prior approval of an engineer.
17. Install and load vertically unless indicated otherwise.
18. Use of green or treated lumber may pose unacceptable environmental, health or performance risks. Consult with project engineer before use.
19. Review all portions of this design (front, back, words and pictures) before use. Reviewing pictures alone is not sufficient.
20. Design assumes manufacture in accordance with ANSI/TPI 1 Quality Criteria.