

		I HAVE RESEARCHED THIS CHAPTER AND THE LOUISIANA STATE UNIFORM CONSTRUCTION CODE AND TO THE BEST OF MY KNOWLEDGE AND BELIEF, THESE DRAWINGS ARE IN COMPLIANCE THEREWITH. I TAKE FULL RESPONSIBILITY FOR THE CONTENTS OF THESE PLANS.	

**MOORE AND ASSOCIATES  
ENGINEERING AND CONSULTING, INC.**

<b>DRAWN BY:</b> LT	Louis Popielarcheck 5317 Stableview Court Holly Springs NC 27540		
<b>CHECKED BY:</b> PDH			
<b>PROJECT NGR:</b> WSM	<b>DATE:</b> 4-12-19	<b>SCALE:</b> NTS	<b>JOB NO:</b> 18378S
<b>CLIENT:</b> CC	<b>SHT.</b> 1	<b>DWG. NO:</b> SK-3	<b>REV.:</b> 0

THIS DOCUMENT IS THE PROPERTY OF MOORE AND ASSOCIATES ENGINEERING AND CONSULTING. THE UNAUTHORIZED REPRODUCTION, COPYING, OR OTHERWISE USE OF THIS DOCUMENT IS STRICTLY PROHIBITED AND ANY INFRINGEMENT THEREUPON MAY BE SUBJECT TO LEGAL ACTION.



	<p><b>Professional Certification.</b> I hereby certify that these documents were prepared or approved by me, and that I am a duly licensed professional engineer under the laws of the State of Maryland, License No. 49744, Expiration Date <u>8/8/20</u></p>		

**MOORE AND ASSOCIATES  
ENGINEERING AND CONSULTING, INC.**

**DRAWN BY:** LT

Louis Popielarcheck  
5317 Stableview Court  
Holly Springs NC 27540

**CHECKED BY:** PDM

**PROJECT MGR:** VSM

**DATE:** 4-12-19

**SCALE:** NTS

**JOB NO:** 18378S

**CLIENT:** CC

**SHT:** 1A

**DWG. NO:** SK-3

**REV:** 0

THIS DOCUMENT IS THE PROPERTY OF MOORE AND ASSOCIATES ENGINEERING AND CONSULTING. THE UNAUTHORIZED REPRODUCTION, COPYING, OR OTHERWISE USE OF THIS DOCUMENT IS STRICTLY PROHIBITED AND ANY INFRINGEMENT THEREUPON MAY BE SUBJECT TO LEGAL ACTION.

**INSTALLATION NOTES AND SPECIFICATIONS**

1. DESIGN IS FOR MAXIMUM 30'-0" WIDE x 20'-0" EAVE HEIGHT ENCLOSED STRUCTURES.
2. DESIGN WAS DONE IN ACCORDANCE WITH THE 2018 NORTH CAROLINA BUILDING CODE, 2017 FLORIDA BUILDING CODE (FBC) 6TH EDITION, 2018 INTERNATIONAL BUILDING CODE (IBC), 2006 IBC, 2009 IBC, 2012 IBC, 2015 IBC, AND 2018 IBC.
3. DESIGN LOADS ARE AS FOLLOWS:
  - A) DEAD LOAD = 1.5 PSF
  - B) LIVE LOAD = 12 PSF
  - C) GROUND SNOW LOAD = 33 PSF AT 5'-0" O.C. SPACING.  
 = 42 PSF AT 4'-0" O.C. SPACING.  
 30 PSF (WITH U-CHANNEL PEAK BRACE) W ≤ 26'-0"  
 (UNBALANCED SNOW LOADS DUE TO DRIFTING HAVE NOT BEEN EVALUATED.)
4. ULTIMATE WIND SPEED 105 TO 143 MPH (NOMINAL WIND SPEED 82 TO 110 MPH).  
 MAXIMUM RAFTER/COLUMN AND END COLUMN SPACING = 5.0 FEET
5. ULTIMATE WIND SPEED 144 TO 155 MPH (NOMINAL WIND SPEED 111 TO 120 MPH).  
 MAXIMUM RAFTER/COLUMN AND END COLUMN SPACING = 4.0 FEET
6. END WALL COLUMNS (POSTS) ARE SIMILAR TO SIDE WALL POSTS IN SIZE AND SPACING UNLESS NOTED OTHERWISE.
7. LDW HAZARD RISK CATEGORY I.
8. WIND EXPOSURE CATEGORY B.
9. SPECIFICATIONS APPLICABLE TO 29 GAUGE METAL PANELS FASTENED DIRECTLY TO 2 1/4" x 2 1/4" - 14 GAUGE TUBE STEEL (TS) FRAMING MEMBERS (UNLESS NOTED OTHERWISE).
10. AVERAGE FASTENER SPACING ON-CENTERS ALONG RAFTERS OR HAT CHANNELS, AND COLUMNS (INTERIOR OR END) = 8 INCHES.
11. FASTENERS CONSIST OF #12-14x3/4" (UNLESS OTHERWISE NOTED) SELF-DRILLING FASTENER (SDF), USE CONTROL SEAL WASHER WITH EXTERIOR FASTENERS. SPECIFICATIONS APPLICABLE ONLY FOR MEAN ROOF HEIGHT OF 20 FEET OR LESS, AND ROOF SLOPES OF 14" (3:12) PITCH OR LESS. SPACING REQUIREMENTS FOR OTHER ROOF HEIGHTS AND/OR SLOPES MAY VARY.
12. ANCHORS SHALL BE INSTALLED THROUGH BASE RAIL WITHIN 6" OF EACH COLUMN.
13. STANDARD GROUND ANCHORS (SOIL NAILS) CONSIST OF #4 REBAR W/ WELDED NUT x 36" LONG. SOIL NAILS MAY BE USED FOR MAXIMUM WIND V = 145 MPH AND IN SUITABLE SOIL CONDITIONS. OPTIONAL ANCHORAGE MAY BE USED IN SUITABLE SOILS AND MUST BE USED FOR WIND V > 145 MPH AND/OR IN UNSUITABLE SOILS AS NOTED.
14. WIND FORCES GOVERN OVER SEISMIC FORCES. SEISMIC PARAMETERS ANALYZED ARE:  
 SOIL SITE CLASS = D  
 RISK CATEGORY I/II/III  
 R= 3.25                      I<sub>e</sub>= 1.0  
 S<sub>ps</sub>= 2.039 g              V= C<sub>s</sub>W  
 S<sub>dl</sub>= 1.258 g
15. DOOR AND WINDOW PRESSURES APPLICABLE TO THE STATE OF FLORIDA.

\*\*\*CarpportCentral Authorized Manufacturer Of Customers Use Only\*\*\*

<b>MOORE AND ASSOCIATES ENGINEERING AND CONSULTING, INC.</b>	DRAWN BY: LT	Louis Popielarcheck 5317 Stableview Court Holly Springs NC 27540		
	CHECKED BY: PDH			
THIS DOCUMENT IS THE PROPERTY OF MOORE AND ASSOCIATES ENGINEERING AND CONSULTING. THE UNAUTHORIZED REPRODUCTION, COPYING, OR OTHERWISE USE OF THIS DOCUMENT IS STRICTLY PROHIBITED AND ANY INFRINGEMENT THEREUPON MAY BE SUBJECT TO LEGAL ACTION.	PROJECT MGR: WSM	DATE: 4-12-19	SCALE: NTS	JOB NO: 18378S
	CLIENT: CC	SHT. 3	DWG. NO: SK-3	REV: 0



**BOX EAVE FRAME RAFTER STRUCTURE**

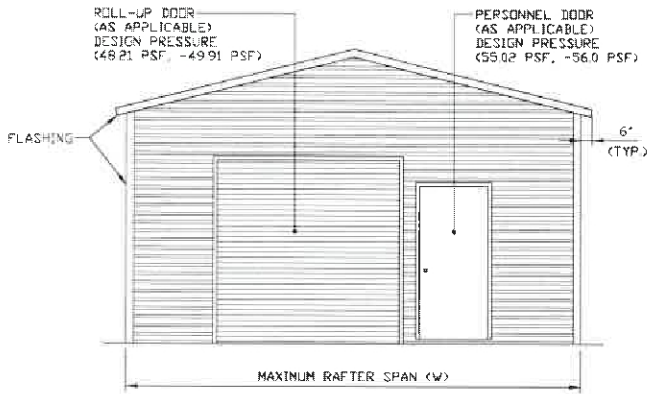

**TYPICAL END ELEVATION-HORIZONTAL ROOF**  
SCALE: NTS

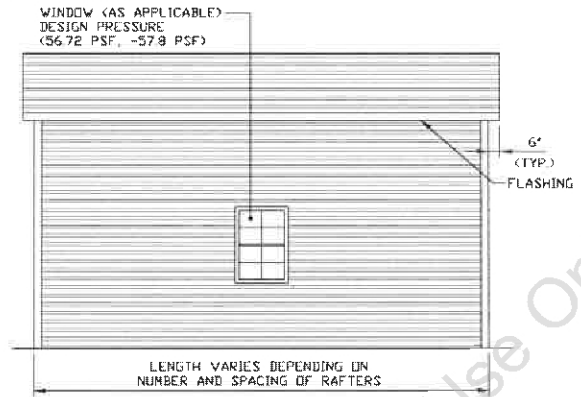

**TYPICAL SIDE ELEVATION-HORIZONTAL ROOF**  
SCALE: NTS

**BOW FRAME RAFTER STRUCTURE**

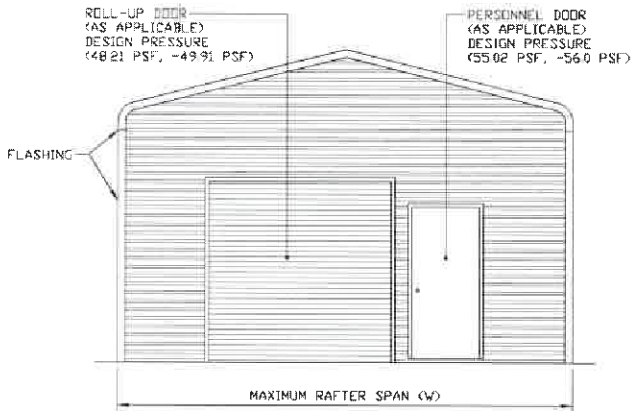

**TYPICAL END ELEVATION**  
SCALE: NTS

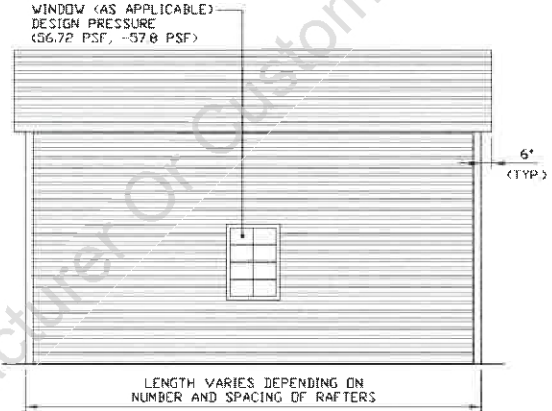

**TYPICAL END ELEVATION**  
SCALE: NTS

**MOORE AND ASSOCIATES  
ENGINEERING AND CONSULTING, INC.**

**DRAWN BY: LT**

Louis Popielarcheck  
5317 Stableview Court  
Holly Springs NC 27540

**CHECKED BY: PDM**

**PROJECT MGR: WSM**

**DATE: 4-12-19**

**SCALE: NTS**

**JOB NO: 18378S**

**CLIENT: CC**

**SHT. 3A**

**DWG. NO: SK-3**

**REV: 0**

THIS DOCUMENT IS THE PROPERTY OF MOORE AND ASSOCIATES ENGINEERING AND CONSULTING. THE UNAUTHORIZED REPRODUCTION, COPYING, OR OTHERWISE USE OF THIS DOCUMENT IS STRICTLY PROHIBITED AND ANY INFRINGEMENT THEREUPON MAY BE SUBJECT TO LEGAL ACTION.



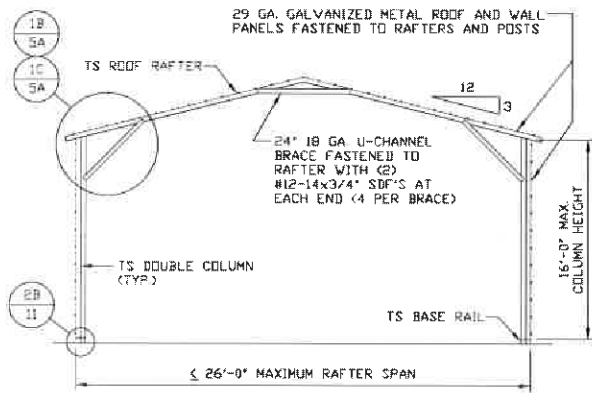

**TYPICAL RAFTER/COLUMN END FRAME SECTION**

SCALE: NTS

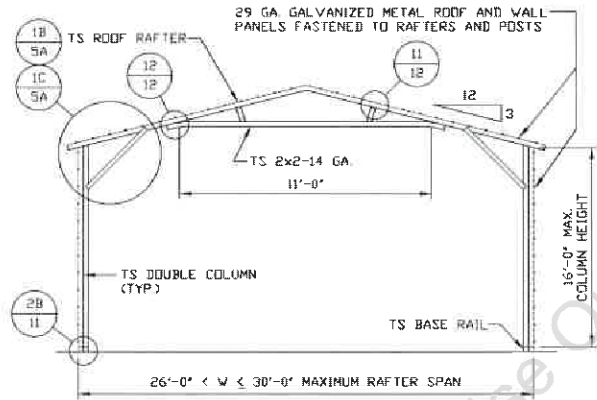

**TYPICAL RAFTER/COLUMN END FRAME SECTION**

SCALE: NTS

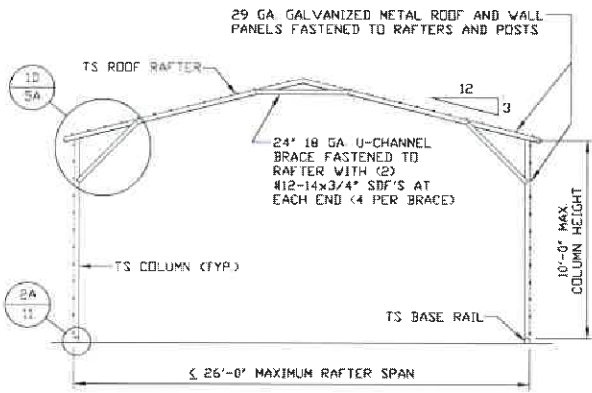

**TYPICAL RAFTER/COLUMN END FRAME SECTION**

SCALE: NTS

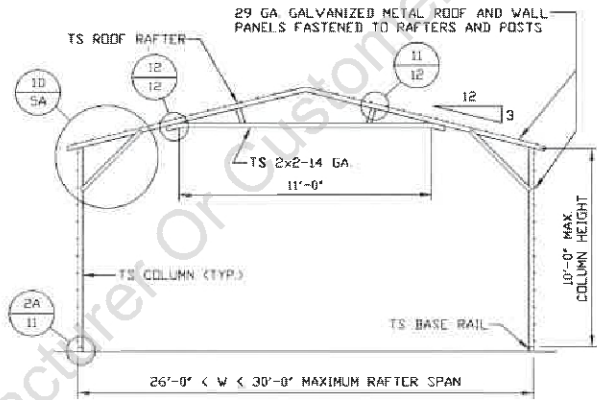

**TYPICAL RAFTER/COLUMN END FRAME SECTION**

SCALE: NTS

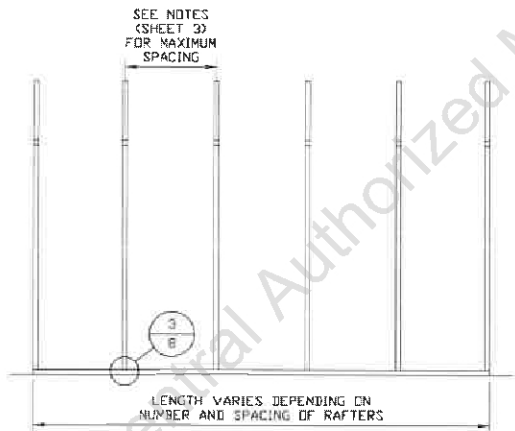

**TYPICAL RAFTER/COLUMN SIDE FRAMING SECTION**

SCALE: NTS

**MOORE AND ASSOCIATES  
ENGINEERING AND CONSULTING, INC.**

**DRAWN BY: LT**

Louis Popielarcheck  
5317 Stableview Court  
Holly Springs NC 27540

**CHECKED BY: PDM**

**PROJECT MGR: WSM**

**DATE: 4-12-19**

**SCALE: NTS**

**JOB NO: 18378S**

**CLIENT: CC**

**SHT. 4A**

**DWG. NO: SK-3**

**REV: 0**

THIS DOCUMENT IS THE PROPERTY OF MOORE AND ASSOCIATES ENGINEERING AND CONSULTING. THE UNAUTHORIZED REPRODUCTION, COPYING, OR OTHERWISE USE OF THIS DOCUMENT IS STRICTLY PROHIBITED AND ANY INFRINGEMENT THEREUPON MAY BE SUBJECT TO LEGAL ACTION.

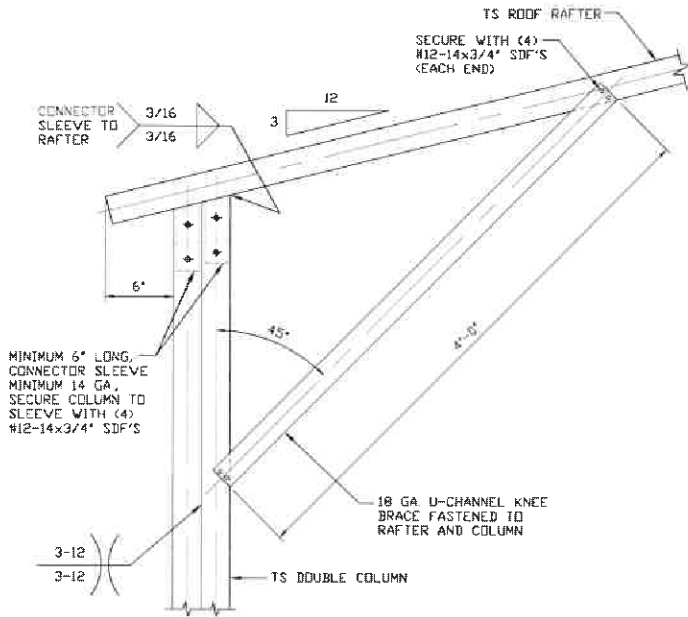

**1B**  
**BOX EAVE RAFTER COLUMN CONNECTION DETAIL FOR HEIGHTS 12'-0" < TO ≤ 16'-0"**  
 SCALE: NTS

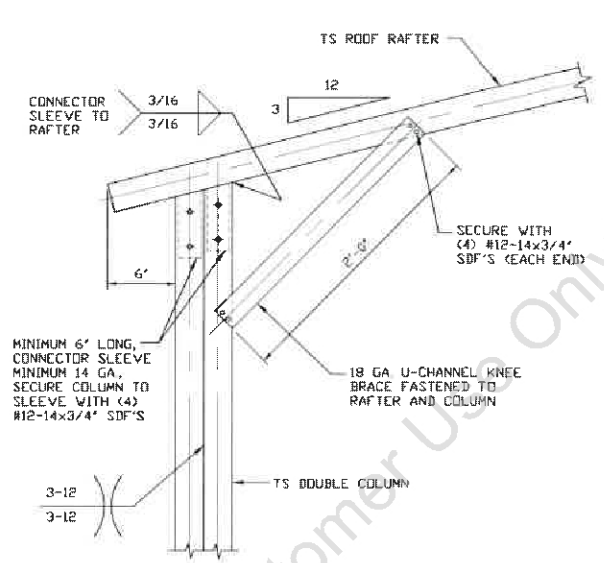

**1C**  
**BOX EAVE RAFTER COLUMN CONNECTION DETAIL FOR HEIGHTS 10'-0" < TO ≤ 12'-0"**  
 SCALE: NTS

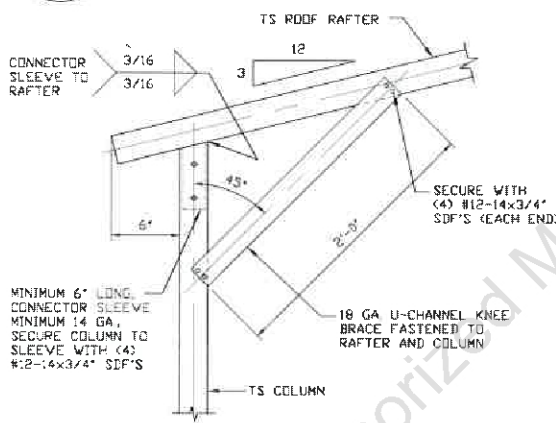

**1D**  
**BOX EAVE RAFTER COLUMN CONNECTION DETAIL FOR HEIGHTS ≤ 10'-0"**  
 SCALE: NTS

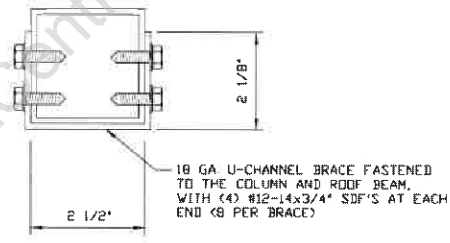

**BRACE SECTION**  
 SCALE: NTS

**MOORE AND ASSOCIATES ENGINEERING AND CONSULTING, INC.**

<b>DRAWN BY:</b> LT	Louis Popielarcheck 5317 Stableview Court Holly Springs NC 27540		
<b>CHECKED BY:</b> PDH			
<b>PROJECT MGR:</b> VSM	<b>DATE:</b> 4-12-19	<b>SCALE:</b> NTS	<b>JOB NO:</b> 18378S
<b>CLIENT:</b> CC	<b>SHT:</b> 5A	<b>DWG. NO:</b> SK-3	<b>REV:</b> 0

THIS DOCUMENT IS THE PROPERTY OF MOORE AND ASSOCIATES ENGINEERING AND CONSULTING. THE UNAUTHORIZED REPRODUCTION, COPYING, OR OTHERWISE USE OF THIS DOCUMENT IS STRICTLY PROHIBITED AND ANY INFRINGEMENT THEREUPON MAY BE SUBJECT TO LEGAL ACTION.



### BASE RAIL ANCHORAGE OPTIONS

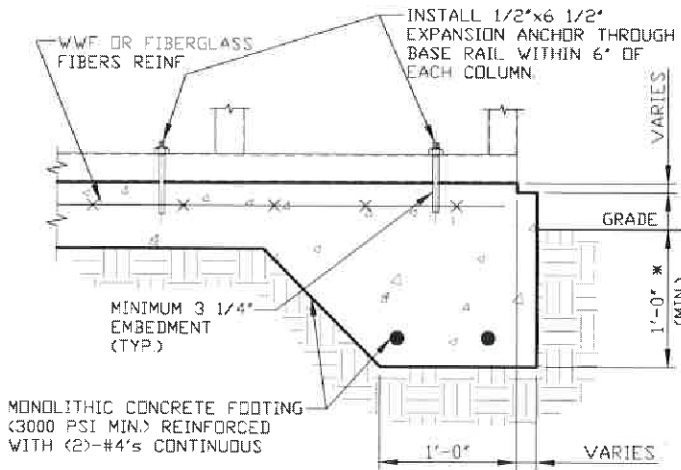

**3A CONCRETE MONOLITHIC SLAB BASE RAIL ANCHORAGE**  
 SCALE: NTS  
 MINIMUM ANCHOR EDGE DISTANCE IS 4".  
 \* COORDINATE WITH LOCAL CODES/ORD.

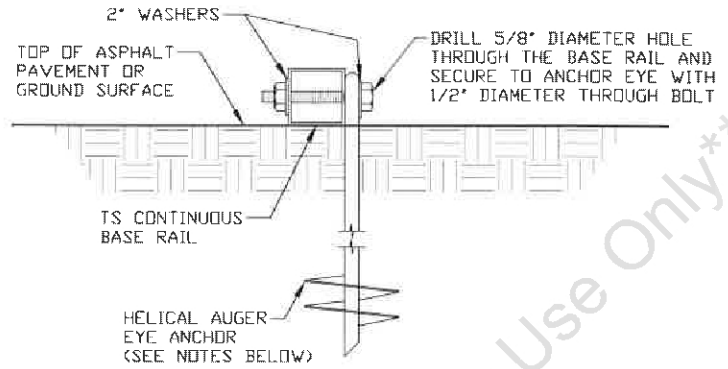

**3B HELICAL AUGER ANCHORAGE**  
 SCALE: NTS (CAN BE USED FOR ASPHALT)

### GENERAL NOTES

NOTE: CONCRETE MONOLITHIC SLAB DESIGN BASED ON MINIMUM SOIL BEARING CAPACITY OF 1,500 PSF.

#### CONCRETE:

CONCRETE SHALL HAVE A MINIMUM SPECIFIED COMPRESSIVE STRENGTH OF 3,000 PSI AT 28 DAYS.

#### COVER OVER REINFORCING STEEL:

FOR FOUNDATIONS, MINIMUM CONCRETE COVER OVER REINFORCING BARS SHALL BE PER ACI-318:  
 3" IN FOUNDATIONS WHERE THE CONCRETE IS CAST AGAINST AND PERMANENTLY IN CONTACT WITH THE EARTH OR EXPOSED TO THE EARTH OR WEATHER, AND 1 1/2" ELSEWHERE.

#### REINFORCING STEEL:

THE TURNDOWN REINFORCING STEEL SHALL BE ASTM A615 GRADE 60. THE SLAB REINFORCEMENT SHALL BE WELDED WIRE FABRIC MEETING ASTM A185 OR FIBERGLASS FIBER REINFORCEMENT.

#### REINFORCEMENT MAY BE BENT IN THE SHOP OR THE FIELD PROVIDED:

- 1 REINFORCEMENT IS BENT COLD.
- 2 THE DIAMETER OF THE BEND, MEASURED ON THE INSIDE OF THE BAR, IS NOT LESS THAN SIX-BAR DIAMETERS.
- 3 REINFORCEMENT PARTIALLY EMBEDDED IN CONCRETE SHALL NOT BE FIELD BENT.

#### HELICAL AUGER ANCHOR NOTES:

- 1 FOR VERY DENSE AND/OR CEMENTED SANDS, COARSE GRAVEL AND COBBLES, CALICHE, PRELOADED SILTS AND CLAYS, USE MINIMUM (2) 4" HELICES WITH MINIMUM 30' EMBEDMENT OR SINGLE 6" HELIX WITH MINIMUM 50' EMBEDMENT.
- 2 FOR CORAL USE MINIMUM (2) 4" HELICES WITH MINIMUM 30' EMBEDMENT OR SINGLE 6" HELIX WITH MINIMUM 50' EMBEDMENT.
- 3 FOR MEDIUM DENSE COARSE SANDS, SANDY GRAVELS, VERY STIFF SILTS, AND CLAYS USE MINIMUM (2) 4" HELICES WITH MINIMUM 30 INCH EMBEDMENT OR SINGLE 6" HELIX WITH MINIMUM 50' EMBEDMENT.
- 4 FOR LOOSE TO MEDIUM DENSE SANDS, FIRM TO STIFF CLAYS AND SILTS ALLUVIAL FILL, USE MINIMUM (2) 6" HELICES WITH MINIMUM 50' EMBEDMENT.
- 5 FOR VERY LOSE TO MEDIUM DENSE SANDS, FIRM TO STIFFER CLAYS AND SILTS, ALLUVIAL FILL, USE MINIMUM (2) 8" HELICES WITH MINIMUM 60' EMBEDMENT.

<b>MOORE AND ASSOCIATES ENGINEERING AND CONSULTING, INC.</b>	DRAWN BY: LT	Louis Popielarcheck 5317 Stableview Court Holly Springs NC 27540			
	CHECKED BY: PDH	PROJECT MGR: WSM	DATE: 4-12-19	SCALE: NTS	JOB NO: 18378S
THIS DOCUMENT IS THE PROPERTY OF MOORE AND ASSOCIATES ENGINEERING AND CONSULTING. THE UNAUTHORIZED REPRODUCTION, COPYING, OR OTHERWISE USE OF THIS DOCUMENT IS STRICTLY PROHIBITED AND ANY INFRINGEMENT THEREUPON MAY BE SUBJECT TO LEGAL ACTION.	CLIENT: CC	SHT. 8	DWG. NO: SK-3	REV: 0	

### BASE RAIL ANCHORAGE OPTIONS

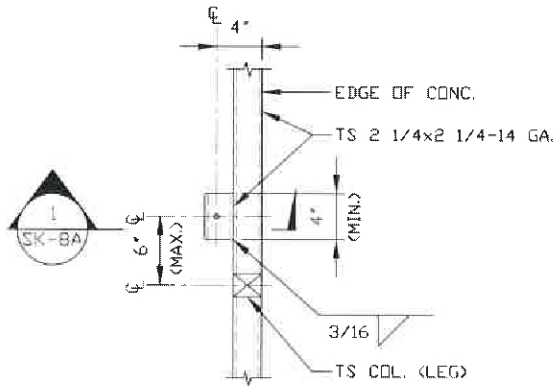

**TYPICAL ANCHOR DETAIL WHEN BASE RAIL IS NEAR EDGE OF CONCRETE**

SCALE: NTS

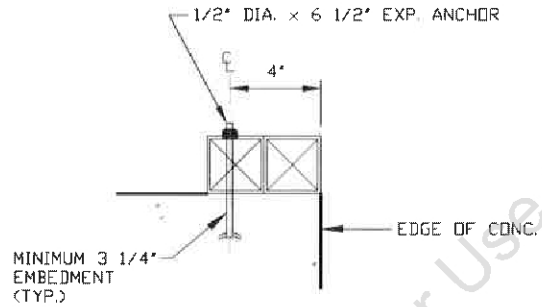

**SECTION 1**  
SCALE: NTS

\*\*\*CarportCentral Authorized Manufacturer Or Customer Use Only\*\*\*

**MOORE AND ASSOCIATES  
ENGINEERING AND CONSULTING, INC.**

<b>DRAWN BY:</b> LT	Louis Popielarcheck 5317 Stableview Court Holly Springs NC 27540		
<b>CHECKED BY:</b> PDH			
<b>PROJECT MGR:</b> WSM	<b>DATE:</b> 4-12-19	<b>SCALE:</b> NTS	<b>JOB NO:</b> 18378S
<b>CLIENT:</b> CC	<b>SHT.</b> 8A	<b>DWG. NO:</b> SK-3	<b>REV.:</b> 0

THIS DOCUMENT IS THE PROPERTY OF MOORE AND ASSOCIATES ENGINEERING AND CONSULTING. THE UNAUTHORIZED REPRODUCTION, COPYING, OR OTHERWISE USE OF THIS DOCUMENT IS STRICTLY PROHIBITED AND ANY INFRINGEMENT THEREUPON MAY BE SUBJECT TO LEGAL ACTION.



**BOX EAVE RAFTER END WALL AND SIDE WALL OPENINGS**

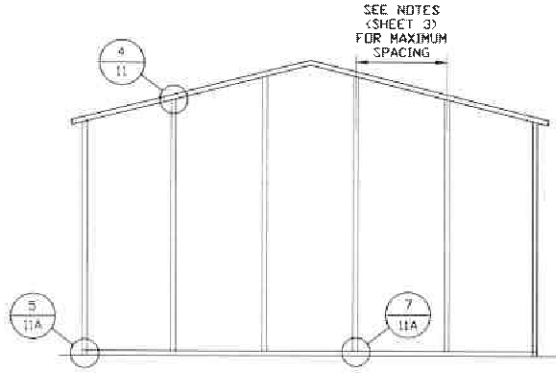

**TYPICAL BOX EAVE RAFTER END WALL FRAMING SECTION**

SCALE: NTS

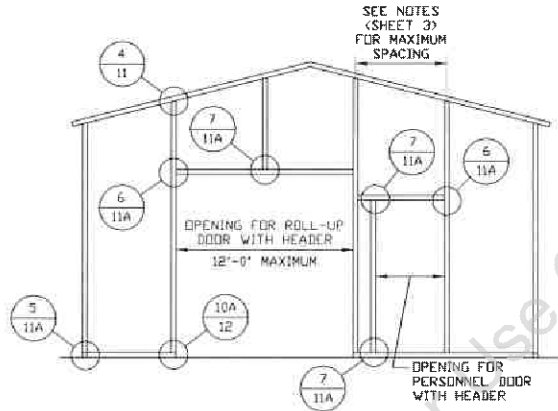

**TYPICAL BOX EAVE RAFTER END WALL OPENINGS FRAMING SECTION**

SCALE: NTS

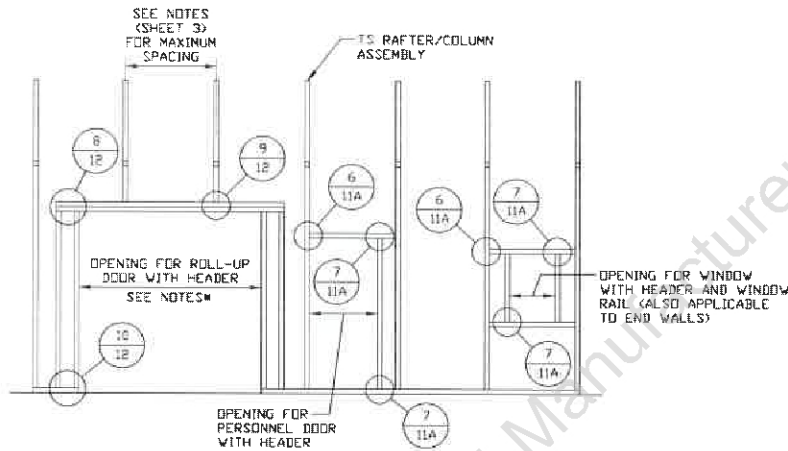

**TYPICAL BOX EAVE RAFTER SIDE WALL OPENINGS FRAMING SECTION**

SCALE: NTS

- NOTES:
- \* 10'-0" MAX. FOR 5'-0" O.C. RAFTER/COLUMN SPACING.
  - \* 9'-0" MAX. FOR 4'-0" O.C. RAFTER/COLUMN SPACING.

<b>MOORE AND ASSOCIATES ENGINEERING AND CONSULTING, INC.</b>	<b>DRAWN BY:</b> LT Louis Popielarcheck 5317 Stableview Court Holly Springs NC 27540			
	<b>CHECKED BY:</b> PDH			
THIS DOCUMENT IS THE PROPERTY OF MOORE AND ASSOCIATES ENGINEERING AND CONSULTING, INC. UNAUTHORIZED REPRODUCTION, COPYING, OR OTHERWISE USE OF THIS DOCUMENT IS STRICTLY PROHIBITED AND ANY INFRINGEMENT THEREUPON MAY BE SUBJECT TO LEGAL ACTION.	<b>PROJECT MGR:</b> WSM	<b>DATE:</b> 4-12-19	<b>SCALE:</b> NTS	<b>JOB NO:</b> 18378S
	<b>CLIENT:</b> CC	<b>SHT.</b> 9	<b>DWG. NO:</b> SK-3	<b>REV:</b> 0

**CONNECTION DETAILS**

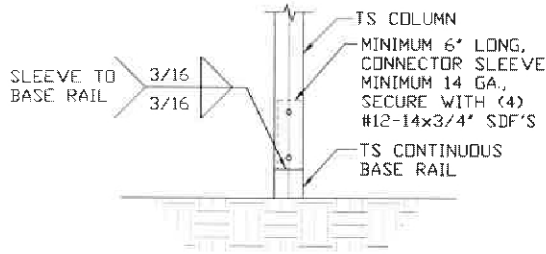

**2A** RAFTER COLUMN/BASE RAIL CONNECTION DETAIL  
SCALE: NTS

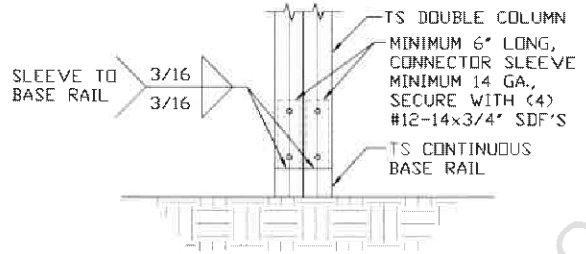

**2B** RAFTER COLUMN/BASE RAIL CONNECTION DETAIL  
SCALE: NTS

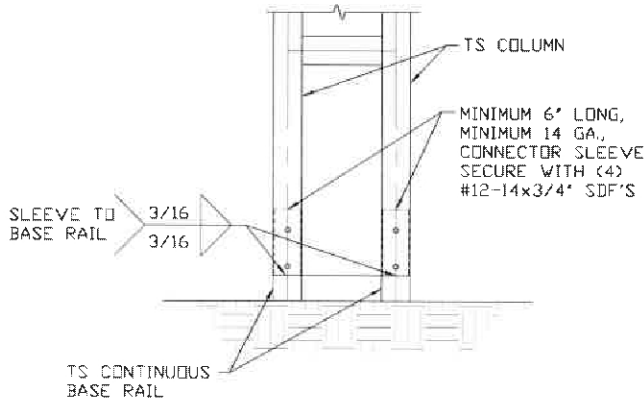

**2C** RAFTER COLUMN/BASE RAIL CONNECTION DETAIL  
SCALE: NTS

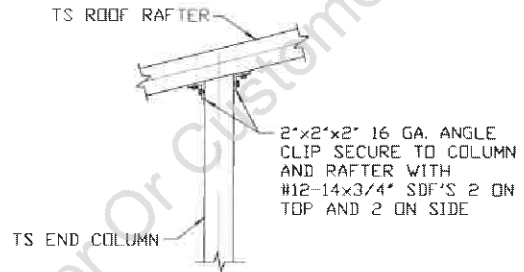

**4** END COLUMN/RAFTER CONNECTION DETAIL  
SCALE: NTS

**MOORE AND ASSOCIATES  
ENGINEERING AND CONSULTING, INC.**

**DRAWN BY:** LT

Louis Popielarcheck  
5317 Stableview Court  
Holly Springs NC 27540

**CHECKED BY:** PDH

**PROJECT MGR:** WSM

**DATE:** 4-12-19

**SCALE:** NTS

**JOB NO:** 18378S

**CLIENT:** CC

**SHT.** 11

**DWG NO:** SK-3

**REV:** 0

THIS DOCUMENT IS THE PROPERTY OF MOORE AND ASSOCIATES ENGINEERING AND CONSULTING. THE UNAUTHORIZED REPRODUCTION, COPYING, OR OTHERWISE USE OF THIS DOCUMENT IS STRICTLY PROHIBITED AND ANY INFRINGEMENT THEREUPON MAY BE SUBJECT TO LEGAL ACTION.



**CONNECTION DETAILS**

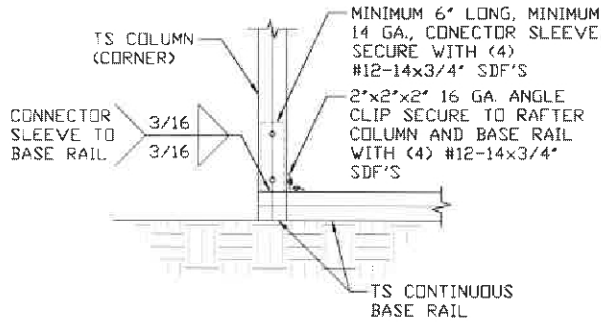

5

**END COLUMN/BASE RAIL CONNECTION DETAIL**

SCALE: NTS

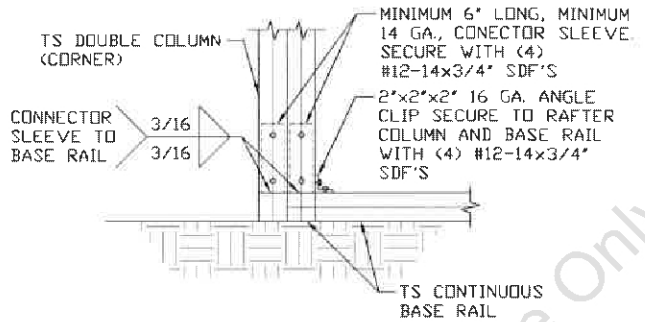

5A

**END COLUMN/BASE RAIL CONNECTION DETAIL**

SCALE: NTS

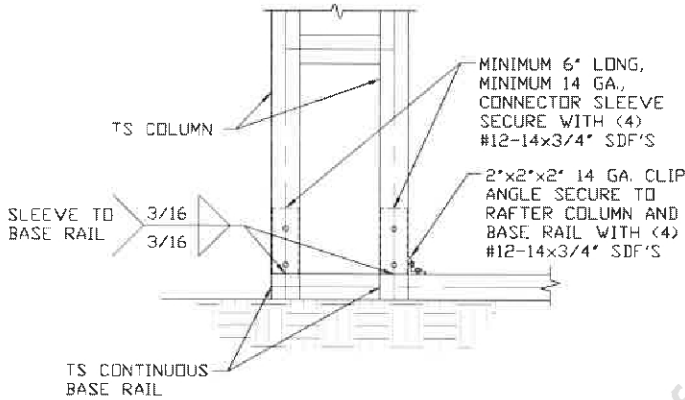

5B

**END COLUMN/BASE RAIL CONNECTION DETAIL**

SCALE: NTS

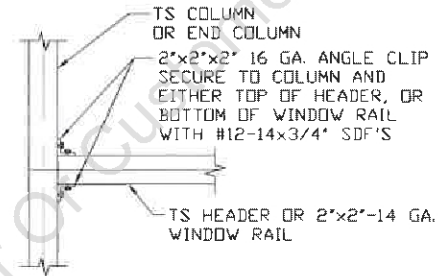

6

**COLUMN OR WINDOW RAIL TO POST CONNECTION DETAIL**

SCALE: NTS

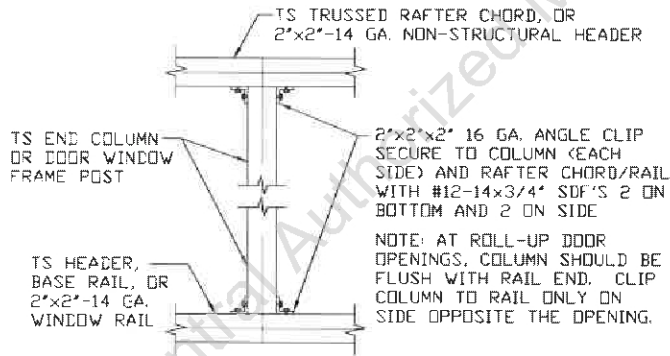

7

**COLUMN TO HEADER, BASE RAIL, OR WINDOW RAIL CONNECTION DETAIL**

SCALE: NTS

**MOORE AND ASSOCIATES ENGINEERING AND CONSULTING, INC.**

**DRAWN BY: LT**

Louis Popielarcheck  
5317 Stableview Court  
Holly Springs NC 27540

**CHECKED BY: PDM**

**PROJECT MGR: WSM**

**DATE: 4-12-19**

**SCALE: NTS**

**JOB NO: 18378S**

**CLIENT: CC**

**SHT. 11A**

**DWG. NO SK-3**

**REV: 0**

THIS DOCUMENT IS THE PROPERTY OF MOORE AND ASSOCIATES ENGINEERING AND CONSULTING. THE UNAUTHORIZED REPRODUCTION, COPYING, OR OTHERWISE USE OF THIS DOCUMENT IS STRICTLY PROHIBITED AND ANY INFRINGEMENT THEREUPON MAY BE SUBJECT TO LEGAL ACTION.

### CONNECTION DETAILS

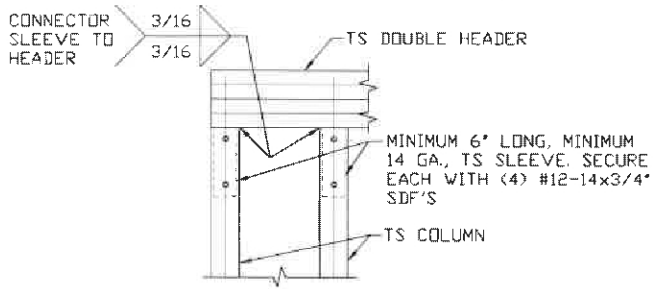

**8** DOUBLE HEADER/COLUMN CONNECTION DETAIL  
SCALE: NTS

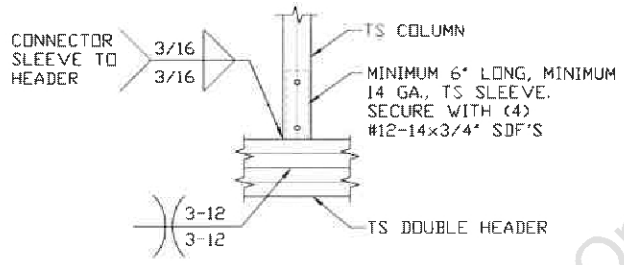

**9** COLUMN/DOUBLE HEADER CONNECTION DETAIL  
SCALE: NTS

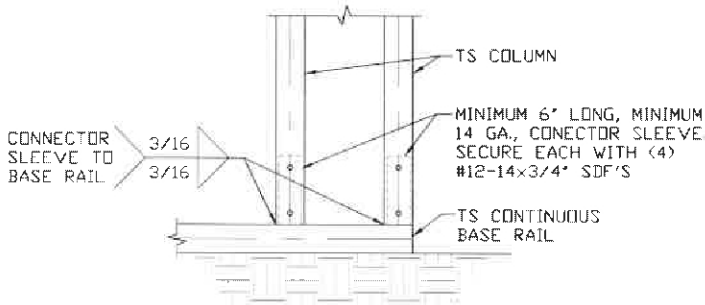

**10** COLUMN/BASE RAIL CONNECTION DETAIL  
SCALE: NTS

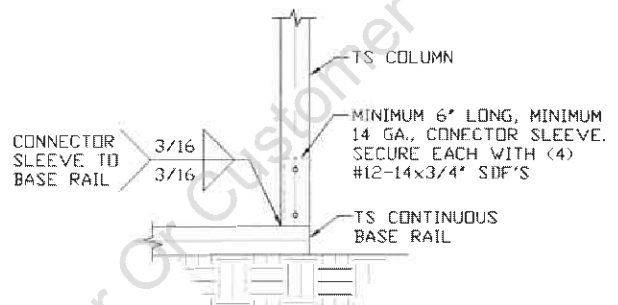

**10A** COLUMN/BASE RAIL CONNECTION DETAIL  
SCALE: NTS

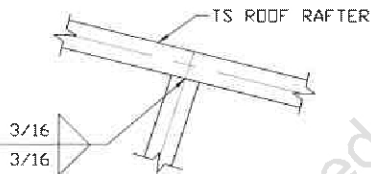

**11** RAFTER TO CHORD CONNECTION DETAIL  
SCALE: NTS

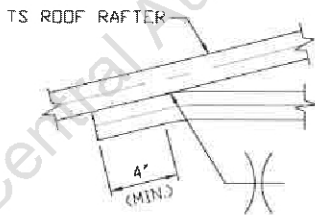

**12** COLLAR TIE CONNECTION DETAIL  
SCALE: NTS

**MOORE AND ASSOCIATES  
ENGINEERING AND CONSULTING, INC.**

**DRAWN BY:** LT

Louis Popielarcheck  
5317 Stableview Court  
Holly Springs NC 27540

**CHECKED BY:** PDH

**PROJECT MGR:** WSM

**DATE:** 4-12-19

**SCALE:** NTS

**JOB NO:** 18378S

**CLIENT:** CC

**SHT.** 12

**DWG. NO:** SK-3

**REV:** 0

THIS DOCUMENT IS THE PROPERTY OF MOORE AND ASSOCIATES ENGINEERING AND CONSULTING. THE UNAUTHORIZED REPRODUCTION, COPYING, OR OTHERWISE USE OF THIS DOCUMENT IS STRICTLY PROHIBITED AND ANY INFRINGEMENT THEREUPON MAY BE SUBJECT TO LEGAL ACTION.



### BOX EAVE RAFTER LEAN-TO OPTIONS

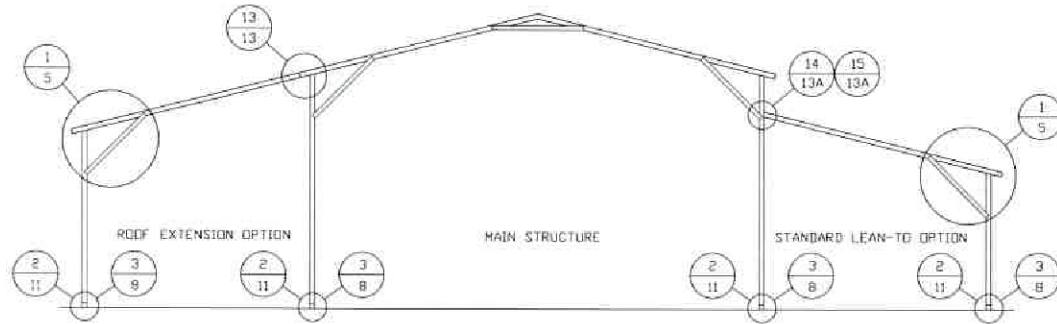

**TYPICAL BOX EAVE RAFTER LEAN-TO OPTIONS FRAMING SECTION (BOTH OPTIONS SHOWN)**  
SCALE: NTS

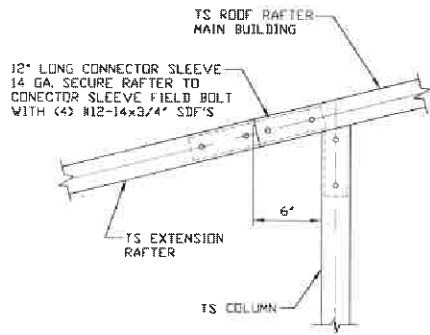

**13 SIDE EXTENSION RAFTER/COLUMN**  
**DETAIL FOR SPAN < 12'-0"**  
SCALE: NTS

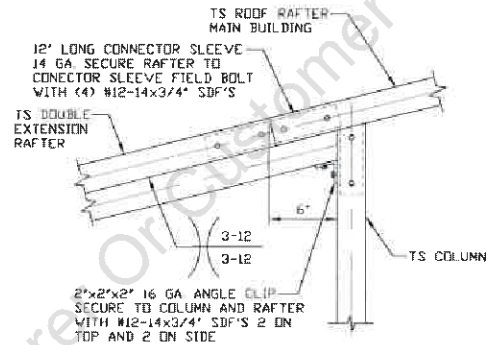

**13A SIDE EXTENSION RAFTER/COLUMN**  
**DETAIL FOR SPAN 12'-0" < L < 16'-0"**  
SCALE: NTS

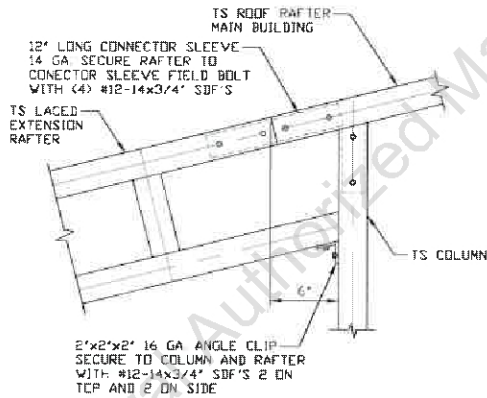

**13B SIDE EXTENSION RAFTER/COLUMN**  
**DETAIL FOR SPAN 16'-0" < L < 20'-0"**  
SCALE: NTS

**MOORE AND ASSOCIATES**  
**ENGINEERING AND CONSULTING, INC.**

<b>DRAWN BY:</b> LT	Louis Popielarcheck 5317 Stableview Court Holly Springs NC 27540		
<b>CHECKED BY:</b> PDH			
<b>PROJECT MGR:</b> VSM	<b>DATE:</b> 4-12-19	<b>SCALE:</b> NTS	<b>JOB NO:</b> 18378S
<b>CLIENT:</b> CC	<b>SHT.</b> 13	<b>DWG. NO:</b> SK-3	<b>REV.</b> 0

THIS DOCUMENT IS THE PROPERTY OF MOORE AND ASSOCIATES ENGINEERING AND CONSULTING. THE UNAUTHORIZED REPRODUCTION, COPYING, OR OTHERWISE USE OF THIS DOCUMENT IS STRICTLY PROHIBITED AND ANY INFRINGEMENT THEREUPON MAY BE SUBJECT TO LEGAL ACTION.

**LEAN-TO OPTIONS**

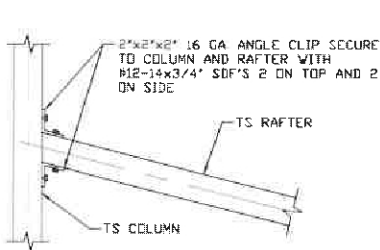

**LEAN-TO RAFTER TO RAFTER COLUMN CONNECTION DETAIL FOR SPAN  $\leq 12'-0''$**   
SCALE: NTS

14

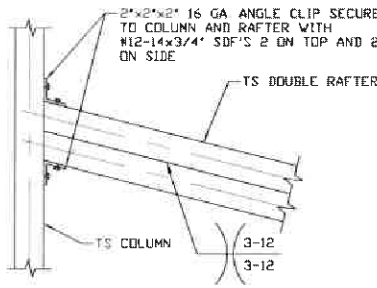

**LEAN-TO RAFTER TO RAFTER COLUMN CONNECTION DETAIL FOR SPAN  $12'-0'' < L \leq 16'-0''$**   
SCALE: NTS

14A

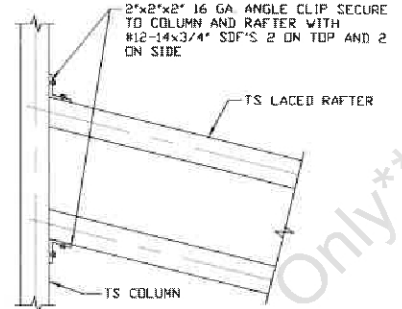

**LEAN-TO RAFTER TO RAFTER COLUMN CONNECTION DETAIL FOR SPAN  $16'-0'' < L \leq 20'-0''$**   
SCALE: NTS

14B

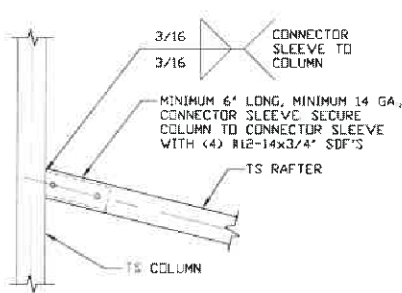

**LEAN-TO RAFTER TO RAFTER COLUMN CONNECTION DETAIL FOR SPAN  $\leq 12'-0''$**   
SCALE: NTS

15

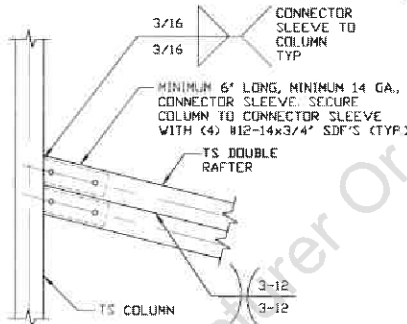

**LEAN-TO RAFTER TO RAFTER COLUMN CONNECTION DETAIL FOR SPAN  $12'-0'' < L \leq 16'-0''$**   
SCALE: NTS

15A

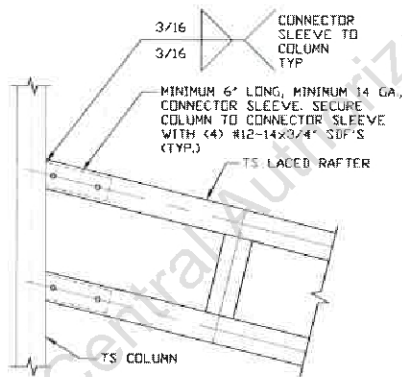

**LEAN-TO RAFTER TO RAFTER COLUMN CONNECTION DETAIL FOR SPAN  $16'-0'' < L \leq 20'-0''$**   
SCALE: NTS

15B

**MOORE AND ASSOCIATES ENGINEERING AND CONSULTING, INC.**

**DRAWN BY:** LT

Louis Popielarcheck  
5317 Stableview Court  
Holly Springs NC 27540

**CHECKED BY:** PDH

**PROJECT MGR:** WSM

**DATE:** 4-12-19

**SCALE:** NTS

**JOB NO:** 18378S

**CLIENT:** CC

**SHT:** 13A

**DWG. NO:** SK-3

**REV.:** 0

THIS DOCUMENT IS THE PROPERTY OF MOORE AND ASSOCIATES ENGINEERING AND CONSULTING. THE UNAUTHORIZED REPRODUCTION, COPYING, OR OTHERWISE USE OF THIS DOCUMENT IS STRICTLY PROHIBITED AND ANY INFRINGEMENT THEREUPON MAY BE SUBJECT TO LEGAL ACTION.