

Job	Truss	Truss Type	Qty	Ply	RICHARDSON	E14419867
P20-04027	G01	Piggyback Base Girder	1	2	Job Reference (optional)	

Longleaf Truss Company,

West End, NC - 27376,

8.330 s Mar 23 2020 MiTek Industries, Inc. Tue May 19 07:20:33 2020 Page 1

ID: gkUVx24Q05glBKvEjRcThWzF1?4-tOcX8xu2wazwHzOB6EBSfHf8wkR0cpwmHmaF4HzF?pi

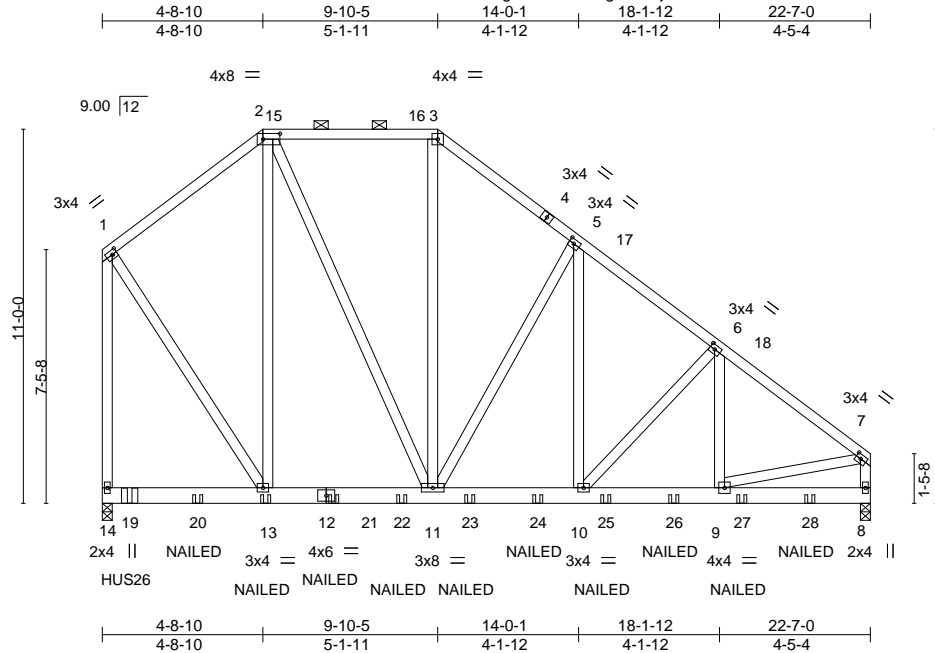

Scale = 1:67.7

Plate Offsets (X,Y)-- [1:0-1-12,0-1-8], [2:0-6-0,0-2-0], [5:0-1-12,0-1-8], [6:0-1-12,0-1-8], [7:0-1-12,0-1-8]

LOADING (psf)	SPACING-	CSI.	DEFL.	PLATES	GRIP
TCLL (roof) 20.0	2-0-0	TC 0.35	in (loc) l/defl L/d	MT20	244/190
Snow (Pf/Pg) 16.5/15.0	Plate Grip DOL 1.15	BC 0.29	Vert(LL) -0.03 10-11 >999 240		
TCDL 10.0	Lumber DOL 1.15	WB 0.31	Vert(CT) -0.04 10-11 >999 180		
BCLL 0.0 *	Rep Stress Incr NO	Matrix-S	Horz(CT) 0.01 8 n/a n/a		
BCDL 10.0	Code IRC2018/TPI2014			Weight: 415 lb	FT = 20%

LUMBER-	BRACING-
TOP CHORD 2x4 SP No.1	TOP CHORD Sheathed or 6-0-0 oc purlins, except end verticals, and 2-0-0 oc purlins (6-0-0 max.); 2-3.
BOT CHORD 2x6 SP No.1	BOT CHORD Rigid ceiling directly applied or 6-0-0 oc bracing.
WEBS 2x4 SP No.3	

REACTIONS. (size) 14=0-3-8, 8=0-3-8
 Max Horz 14=-282(LC 10)
 Max Uplift 14=-212(LC 12), 8=-190(LC 12)
 Max Grav 14=2757(LC 34), 8=1794(LC 34)

FORCES. (lb) - Max. Comp./Max. Ten. - All forces 250 (lb) or less except when shown.
 TOP CHORD 1-2=-987/212, 2-3=-968/229, 3-5=-1320/256, 5-6=-1799/261, 6-7=-1983/239,
 1-14=-1748/212, 7-8=-1631/186
 BOT CHORD 11-13=-57/722, 10-11=-59/1363, 9-10=-120/1545
 WEBS 2-13=-348/129, 2-11=-117/641, 3-11=-180/510, 5-11=-809/163, 5-10=-151/620,
 6-10=-270/88, 1-13=-147/1239, 7-9=-113/1484

NOTES-

- 2-ply truss to be connected together with 10d (0.131"x3") nails as follows:
 Top chords connected as follows: 2x4 - 1 row at 0-9-0 oc.
 Bottom chords connected as follows: 2x6 - 2 rows staggered at 0-8-0 oc.
 Webs connected as follows: 2x4 - 1 row at 0-9-0 oc.
- All loads are considered equally applied to all plies, except if noted as front (F) or back (B) face in the LOAD CASE(S) section. Ply to ply connections have been provided to distribute only loads noted as (F) or (B), unless otherwise indicated.
- Unbalanced roof live loads have been considered for this design.
- Wind: ASCE 7-16; Vult=130mph (3-second gust) Vasd=103mph; TCDL=6.0psf; BCDL=6.0psf; h=12ft; B=45ft; L=24ft; eave=4ft; Cat. II; Exp B; Enclosed; MWFRS (directional); cantilever left and right exposed; end vertical left and right exposed; Lumber DOL=1.60 plate grip DOL=1.60
- TCLL: ASCE 7-16; Pr=20.0 psf (roof LL: Lum DOL=1.15 Plate DOL=1.15); Pg=15.0 psf; Pf=16.5 psf (Lum DOL=1.15 Plate DOL=1.15); Is=1.0; Rough Cat B; Partially Exp.; Ce=1.0; Cs=1.00; Ct=1.10, Lu=50-0-0 Rain surcharge applied to all exposed surfaces with slopes less than 0.500/12 in accordance with IBC 1608.3.4.
- Unbalanced snow loads have been considered for this design.
- Provide adequate drainage to prevent water ponding.
- This truss has been designed for a 10.0 psf bottom chord live load nonconcurrent with any other live loads.
- * This truss has been designed for a live load of 20.0psf on the bottom chord in all areas where a rectangle 3-6-0 tall by 2-0-0 wide will fit between the bottom chord and any other members, with BCDL = 10.0psf.
- Provide mechanical connection (by others) of truss to bearing plate capable of withstanding 100 lb uplift at joint(s) except (jt=lb) 14=212, 8=190.
- This truss is designed in accordance with the 2018 International Residential Code sections R502.11.1 and R802.10.2 and referenced standard ANSI/TPI 1.
- Graphical purlin representation does not depict the size or the orientation of the purlin along the top and/or bottom chord.

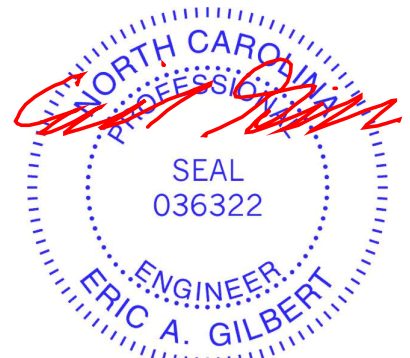

May 19, 2020

Continued on page 2

WARNING - Verify design parameters and READ NOTES ON THIS AND INCLUDED MITEK REFERENCE PAGE MII-7473 rev. 10/03/2015 BEFORE USE.
 Design valid for use only with MiTek® connectors. This design is based only upon parameters shown, and is for an individual building component, not a truss system. Before use, the building designer must verify the applicability of design parameters and properly incorporate this design into the overall building design. Bracing indicated is to prevent buckling of individual truss web and/or chord members only. Additional temporary and permanent bracing is always required for stability and to prevent collapse with possible personal injury and property damage. For general guidance regarding the fabrication, storage, delivery, erection and bracing of trusses and truss systems, see **ANSI/TPI1 Quality Criteria, DSB-89 and BCSI Building Component Safety Information** available from Truss Plate Institute, 218 N. Lee Street, Suite 312, Alexandria, VA 22314.



818 Soundside Road
 Edenton, NC 27932

Job	Truss	Truss Type	Qty	Ply	RICHARDSON	E14419867
P20-04027	G01	Piggyback Base Girder	1	2	Job Reference (optional)	

Longleaf Truss Company, West End, NC - 27376,

8.330 s Mar 23 2020 MiTek Industries, Inc. Tue May 19 07:20:33 2020 Page 2
 ID:gkUVx24QO5glBKvEjRcThWzF1?4-tOcX8xu2wazwHzOB6EBSfhf8wkR0cpwmHmaF4HzF?pi

NOTES-

- 13) Use Simpson Strong-Tie HUS26 (14-10d Girder, 4-10d Truss) or equivalent at 0-9-10 from the left end to connect truss(es) to back face of bottom chord.
- 14) Fill all nail holes where hanger is in contact with lumber.
- 15) "NAILED" indicates 3-10d (0.148"x3") or 3-12d (0.148"x3.25") toe-nails per NDS guidelines.

LOAD CASE(S) Standard

1) Dead + Snow (balanced): Lumber Increase=1.15, Plate Increase=1.15

Uniform Loads (plf)

Vert: 1-2=-43, 2-3=-53, 3-7=-43, 8-14=-20

Concentrated Loads (lb)

Vert: 12=-152(B) 13=-152(B) 19=-1106(B) 20=-152(B) 22=-152(B) 23=-152(B) 24=-164(B) 25=-164(B) 26=-164(B) 27=-164(B) 28=-164(B)

WARNING - Verify design parameters and READ NOTES ON THIS AND INCLUDED MITEK REFERENCE PAGE MII-7473 rev. 10/03/2015 BEFORE USE.

Design valid for use only with MiTek® connectors. This design is based only upon parameters shown, and is for an individual building component, not a truss system. Before use, the building designer must verify the applicability of design parameters and properly incorporate this design into the overall building design. Bracing indicated is to prevent buckling of individual truss web and/or chord members only. Additional temporary and permanent bracing is always required for stability and to prevent collapse with possible personal injury and property damage. For general guidance regarding the fabrication, storage, delivery, erection and bracing of trusses and truss systems, see **ANSI/TPI1 Quality Criteria, DSB-89 and BCSI Building Component Safety Information** available from Truss Plate Institute, 218 N. Lee Street, Suite 312, Alexandria, VA 22314.



818 Soundside Road
 Edenton, NC 27932

Job	Truss	Truss Type	Qty	Ply	RICHARDSON	E14419868
P20-04027	PB01	Piggyback	21	1	Job Reference (optional)	

Longleaf Truss Company,

West End, NC - 27376,

8.330 s Mar 23 2020 MiTek Industries, Inc. Tue May 19 07:20:34 2020 Page 1
 ID: gkUVx24QO5glBKvEjRcThWzFI?4-LaAvLHughu5nv7zOgxjhCUBMJ7qtLJcWwQJocjzF?ph

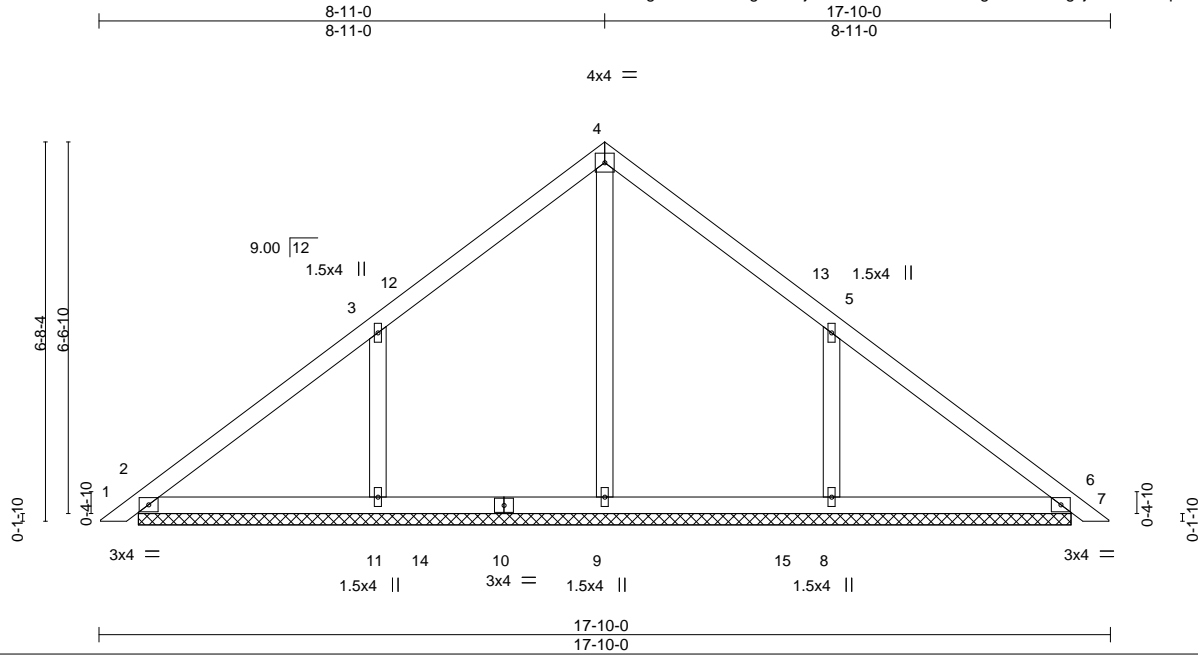

Scale = 1:40.6

LOADING (psf)	SPACING-	CSI.	DEFL.	PLATES	GRIP
TCLL (roof) 20.0	2-0-0	TC 0.18	in (loc) l/defl L/d	MT20	244/190
Snow (Pf/Pg) 11.6/15.0	Plate Grip DOL 1.15	BC 0.12	Vert(LL) 0.00 7 n/r 120		
TCDL 10.0	Lumber DOL 1.15	WB 0.11	Vert(CT) 0.01 7 n/r 120		
BCLL 0.0 *	Rep Stress Incr YES	Matrix-S	Horz(CT) 0.00 6 n/a n/a		
BCDL 10.0	Code IRC2018/TPI2014			Weight: 75 lb	FT = 20%

LUMBER-

TOP CHORD 2x4 SP No.1
 BOT CHORD 2x4 SP No.1
 OTHERS 2x4 SP No.3

BRACING-

TOP CHORD Sheathed or 6-0-0 oc purlins.
 BOT CHORD Rigid ceiling directly applied or 10-0-0 oc bracing.

REACTIONS.

All bearings 16-5-6.
 (lb) - Max Horz 2=-129(LC 10)
 Max Uplift All uplift 100 lb or less at joint(s) 11, 8
 Max Grav All reactions 250 lb or less at joint(s) 2, 6 except 9=330(LC 24), 11=496(LC 24), 8=495(LC 25)

FORCES. (lb) - Max. Comp./Max. Ten. - All forces 250 (lb) or less except when shown.

WEBS 3-11=-306/117, 5-8=-305/117

NOTES-

- Unbalanced roof live loads have been considered for this design.
- Wind: ASCE 7-16; Vult=130mph (3-second gust) Vasd=103mph; TCDL=6.0psf; BCDL=6.0psf; h=12ft; B=45ft; L=24ft; eave=4ft; Cat. II; Exp B; Enclosed; MWFRS (directional); cantilever left and right exposed; end vertical left and right exposed; Lumber DOL=1.60 plate grip DOL=1.60
- TCLL: ASCE 7-16; Pr=20.0 psf (roof LL: Lum DOL=1.15 Plate DOL=1.15); Pg=15.0 psf; Pf=11.6 psf (Lum DOL=1.15 Plate DOL=1.15); Is=1.0; Rough Cat B; Partially Exp.; Ce=1.0; Cs=1.00; Ct=1.10
- Unbalanced snow loads have been considered for this design.
- This truss has been designed for greater of min roof live load of 12.0 psf or 1.00 times flat roof load of 11.6 psf on overhangs non-concurrent with other live loads.
- Gable requires continuous bottom chord bearing.
- This truss has been designed for a 10.0 psf bottom chord live load nonconcurrent with any other live loads.
- * This truss has been designed for a live load of 20.0psf on the bottom chord in all areas where a rectangle 3-6-0 tall by 2-0-0 wide will fit between the bottom chord and any other members, with BCDL = 10.0psf.
- Provide mechanical connection (by others) of truss to bearing plate capable of withstanding 100 lb uplift at joint(s) 11, 8.
- This truss is designed in accordance with the 2018 International Residential Code sections R502.11.1 and R802.10.2 and referenced standard ANSI/TPI 1.
- See Standard Industry Piggyback Truss Connection Detail for Connection to base truss as applicable, or consult qualified building designer.

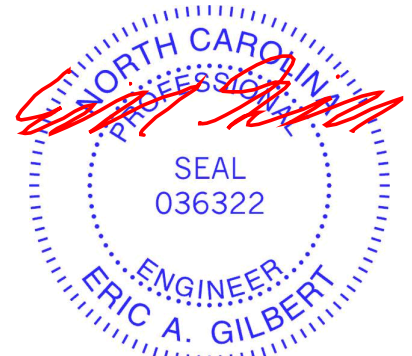

May 19, 2020

WARNING - Verify design parameters and READ NOTES ON THIS AND INCLUDED MITEK REFERENCE PAGE MII-7473 rev. 10/03/2015 BEFORE USE.

Design valid for use only with MiTek® connectors. This design is based only upon parameters shown, and is for an individual building component, not a truss system. Before use, the building designer must verify the applicability of design parameters and properly incorporate this design into the overall building design. Bracing indicated is to prevent buckling of individual truss web and/or chord members only. Additional temporary and permanent bracing is always required for stability and to prevent collapse with possible personal injury and property damage. For general guidance regarding the fabrication, storage, delivery, erection and bracing of trusses and truss systems, see **ANSI/TPI1 Quality Criteria, DSB-89 and BCSI Building Component Safety Information** available from Truss Plate Institute, 218 N. Lee Street, Suite 312, Alexandria, VA 22314.



818 Soundside Road
 Edenton, NC 27932

Job	Truss	Truss Type	Qty	Ply	RICHARDSON	E14419869
P20-04027	PB02	Piggyback	7	1	Job Reference (optional)	

Longleaf Truss Company,

West End, NC - 27376,

8.330 s Mar 23 2020 MiTek Industries, Inc. Tue May 19 07:20:35 2020 Page 1
 ID: gkUVVx24Q05glBKvEjRcThWzF174-pmkiZdvISCDeWHYaEfEwkikW4X9h4n13k43L89zF?pg

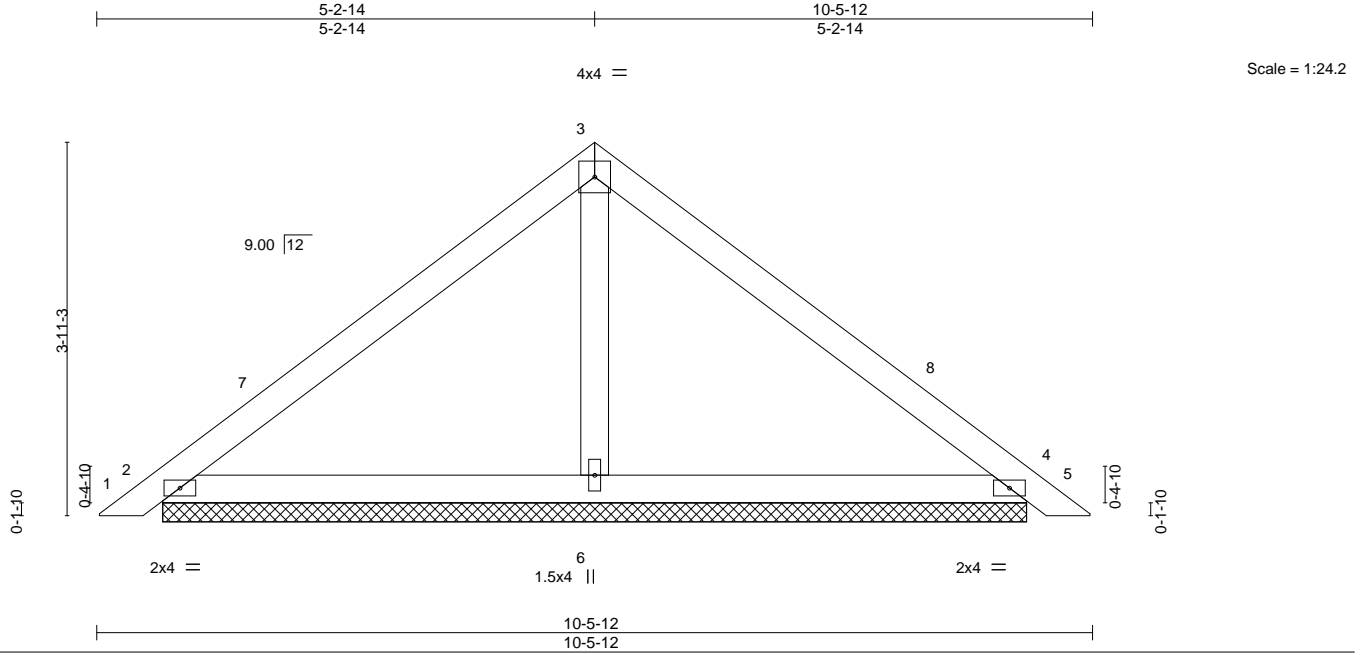

LOADING (psf)	SPACING-	CSI.	DEFL.	PLATES	GRIP
TCLL (roof) 20.0	2-0-0	TC 0.24	in (loc) l/defl L/d	MT20	244/190
Snow (Pf/Pg) 11.6/15.0	Plate Grip DOL 1.15	BC 0.15	Vert(LL) 0.01 5 n/r 120		
TCDL 10.0	Lumber DOL 1.15	WB 0.06	Vert(CT) 0.01 5 n/r 120		
BCLL 0.0 *	Rep Stress Incr YES	Matrix-S	Horz(CT) 0.00 4 n/a n/a		
BCDL 10.0	Code IRC2018/TPI2014			Weight: 38 lb	FT = 20%

LUMBER-	BRACING-
TOP CHORD 2x4 SP No.1	TOP CHORD Sheathed or 6-0-0 oc purlins.
BOT CHORD 2x4 SP No.1	BOT CHORD Rigid ceiling directly applied or 10-0-0 oc bracing.
OTHERS 2x4 SP No.3	

REACTIONS. (size) 2=9-1-2, 4=9-1-2, 6=9-1-2
 Max Horz 2=74(LC 11)
 Max Uplift 2=-26(LC 12), 4=-26(LC 12)
 Max Grav 2=216(LC 2), 4=216(LC 2), 6=348(LC 2)

FORCES. (lb) - Max. Comp./Max. Ten. - All forces 250 (lb) or less except when shown.

- NOTES-**
- Unbalanced roof live loads have been considered for this design.
 - Wind: ASCE 7-16; Vult=130mph (3-second gust) Vasd=103mph; TCDL=6.0psf; BCDL=6.0psf; h=12ft; B=45ft; L=24ft; eave=4ft; Cat. II; Exp B; Enclosed; MWFRS (directional); cantilever left and right exposed; end vertical left and right exposed; Lumber DOL=1.60 plate grip DOL=1.60
 - TCLL: ASCE 7-16; Pr=20.0 psf (roof LL: Lum DOL=1.15 Plate DOL=1.15); Pg=15.0 psf; Pf=11.6 psf (Lum DOL=1.15 Plate DOL=1.15); Is=1.0; Rough Cat B; Partially Exp.; Ce=1.0; Cs=1.00; Ct=1.10
 - Unbalanced snow loads have been considered for this design.
 - This truss has been designed for greater of min roof live load of 12.0 psf or 1.00 times flat roof load of 11.6 psf on overhangs non-concurrent with other live loads.
 - Gable requires continuous bottom chord bearing.
 - This truss has been designed for a 10.0 psf bottom chord live load nonconcurrent with any other live loads.
 - * This truss has been designed for a live load of 20.0psf on the bottom chord in all areas where a rectangle 3-6-0 tall by 2-0-0 wide will fit between the bottom chord and any other members.
 - Provide mechanical connection (by others) of truss to bearing plate capable of withstanding 100 lb uplift at joint(s) 2, 4.
 - This truss is designed in accordance with the 2018 International Residential Code sections R502.11.1 and R802.10.2 and referenced standard ANSI/TPI 1.
 - See Standard Industry Piggyback Truss Connection Detail for Connection to base truss as applicable, or consult qualified building designer.



May 19, 2020

Job	Truss	Truss Type	Qty	Ply	RICHARDSON	E14419870
P20-04027	PB03	Piggyback	1	1	Job Reference (optional)	

Longleaf Truss Company,

West End, NC - 27376,

8.330 s Mar 23 2020 MiTek Industries, Inc. Tue May 19 07:20:36 2020 Page 1

ID: gkUVx24QO5glBKvEjRcThWzFI?4-HzHgmzwxCVLV8R7mnMI9HvHipxWKpDiCzkovgczF?pf

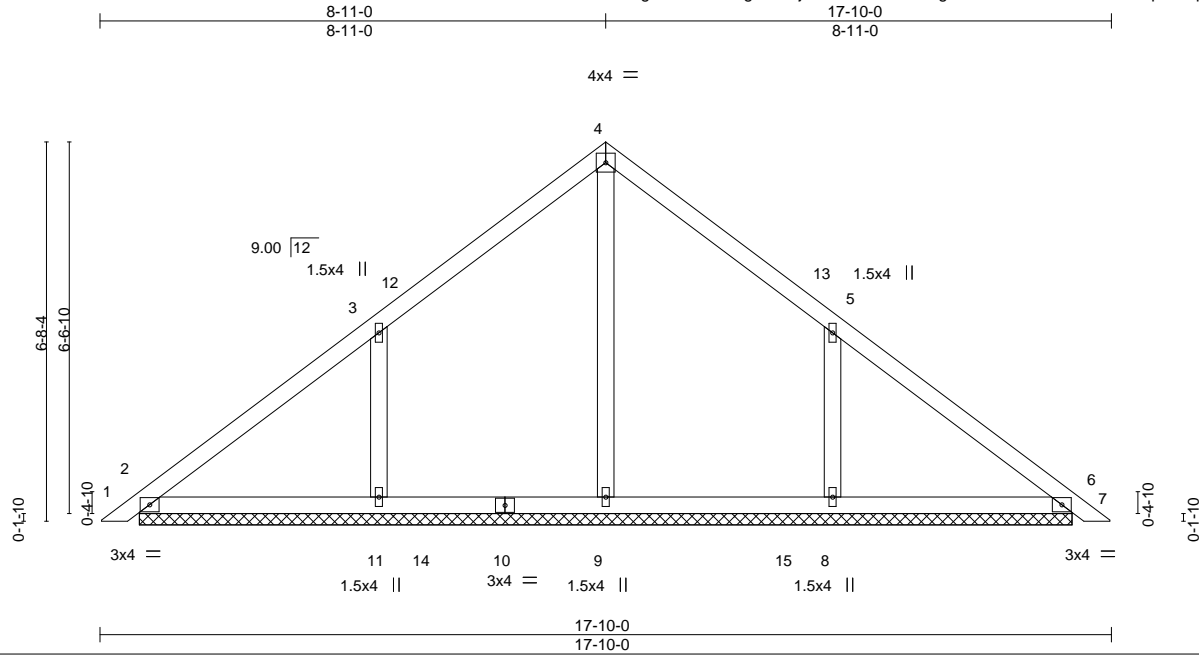

Scale = 1:40.6

LOADING (psf)	SPACING-	CSI.	DEFL.	PLATES	GRIP
TCLL (roof) 20.0	2-0-0	TC 0.18	in (loc) l/defl L/d	MT20	244/190
Snow (Pf/Pg) 11.6/15.0	Plate Grip DOL 1.15	BC 0.12	Vert(LL) 0.00 7 n/r 120		
TCDL 10.0	Lumber DOL 1.15	WB 0.11	Vert(CT) 0.01 7 n/r 120		
BCLL 0.0 *	Rep Stress Incr YES	Matrix-S	Horz(CT) 0.00 6 n/a n/a		
BCDL 10.0	Code IRC2018/TPI2014			Weight: 75 lb	FT = 20%

LUMBER-

TOP CHORD 2x4 SP No.1
 BOT CHORD 2x4 SP No.1
 OTHERS 2x4 SP No.3

BRACING-

TOP CHORD Sheathed or 6-0-0 oc purlins.
 BOT CHORD Rigid ceiling directly applied or 10-0-0 oc bracing.

REACTIONS.

All bearings 16-5-6.

(lb) - Max Horz 2=129(LC 10)

Max Uplift All uplift 100 lb or less at joint(s) 11, 8

Max Grav All reactions 250 lb or less at joint(s) 2, 6 except 9=330(LC 24), 11=496(LC 24), 8=495(LC 25)

FORCES. (lb) - Max. Comp./Max. Ten. - All forces 250 (lb) or less except when shown.

WEBS 3-11=-306/117, 5-8=-305/117

NOTES-

- 1) Unbalanced roof live loads have been considered for this design.
- 2) Wind: ASCE 7-16; Vult=130mph (3-second gust) Vasd=103mph; TCDL=6.0psf; BCDL=6.0psf; h=12ft; B=45ft; L=24ft; eave=4ft; Cat. II; Exp B; Enclosed; MWFRS (directional); cantilever left and right exposed; end vertical left and right exposed; Lumber DOL=1.60 plate grip DOL=1.60
- 3) TCLL: ASCE 7-16; Pr=20.0 psf (roof LL: Lum DOL=1.15 Plate DOL=1.15); Pg=15.0 psf; Pf=11.6 psf (Lum DOL=1.15 Plate DOL=1.15); Is=1.0; Rough Cat B; Partially Exp.; Ce=1.0; Cs=1.00; Ct=1.10
- 4) Unbalanced snow loads have been considered for this design.
- 5) This truss has been designed for greater of min roof live load of 12.0 psf or 1.00 times flat roof load of 11.6 psf on overhangs non-concurrent with other live loads.
- 6) Gable requires continuous bottom chord bearing.
- 7) This truss has been designed for a 10.0 psf bottom chord live load nonconcurrent with any other live loads.
- 8) * This truss has been designed for a live load of 20.0psf on the bottom chord in all areas where a rectangle 3-6-0 tall by 2-0-0 wide will fit between the bottom chord and any other members, with BCDL = 10.0psf.
- 9) Provide mechanical connection (by others) of truss to bearing plate capable of withstanding 100 lb uplift at joint(s) 11, 8.
- 10) This truss is designed in accordance with the 2018 International Residential Code sections R502.11.1 and R802.10.2 and referenced standard ANSI/TPI 1.
- 11) See Standard Industry Piggyback Truss Connection Detail for Connection to base truss as applicable, or consult qualified building designer.



May 19, 2020

WARNING - Verify design parameters and READ NOTES ON THIS AND INCLUDED MITEK REFERENCE PAGE MII-7473 rev. 10/03/2015 BEFORE USE.

Design valid for use only with MiTek® connectors. This design is based only upon parameters shown, and is for an individual building component, not a truss system. Before use, the building designer must verify the applicability of design parameters and properly incorporate this design into the overall building design. Bracing indicated is to prevent buckling of individual truss web and/or chord members only. Additional temporary and permanent bracing is always required for stability and to prevent collapse with possible personal injury and property damage. For general guidance regarding the fabrication, storage, delivery, erection and bracing of trusses and truss systems, see **ANSI/TPI1 Quality Criteria, DSB-89 and BCSI Building Component Safety Information** available from Truss Plate Institute, 218 N. Lee Street, Suite 312, Alexandria, VA 22314.



818 Soundside Road
 Edenton, NC 27932

Job	Truss	Truss Type	Qty	Ply	RICHARDSON	E14419871
P20-04027	PB04	Piggyback	1	1	Job Reference (optional)	

Longleaf Truss Company,

West End, NC - 27376,

8.330 s Mar 23 2020 MiTek Industries, Inc. Tue May 19 07:20:37 2020 Page 1

ID: gkUVx24QO5glBKvEjRcThWzF1?4-19r2_JxZzpTMmaizL4GOq7psaLq8YhoMCOYSD2zF?pe

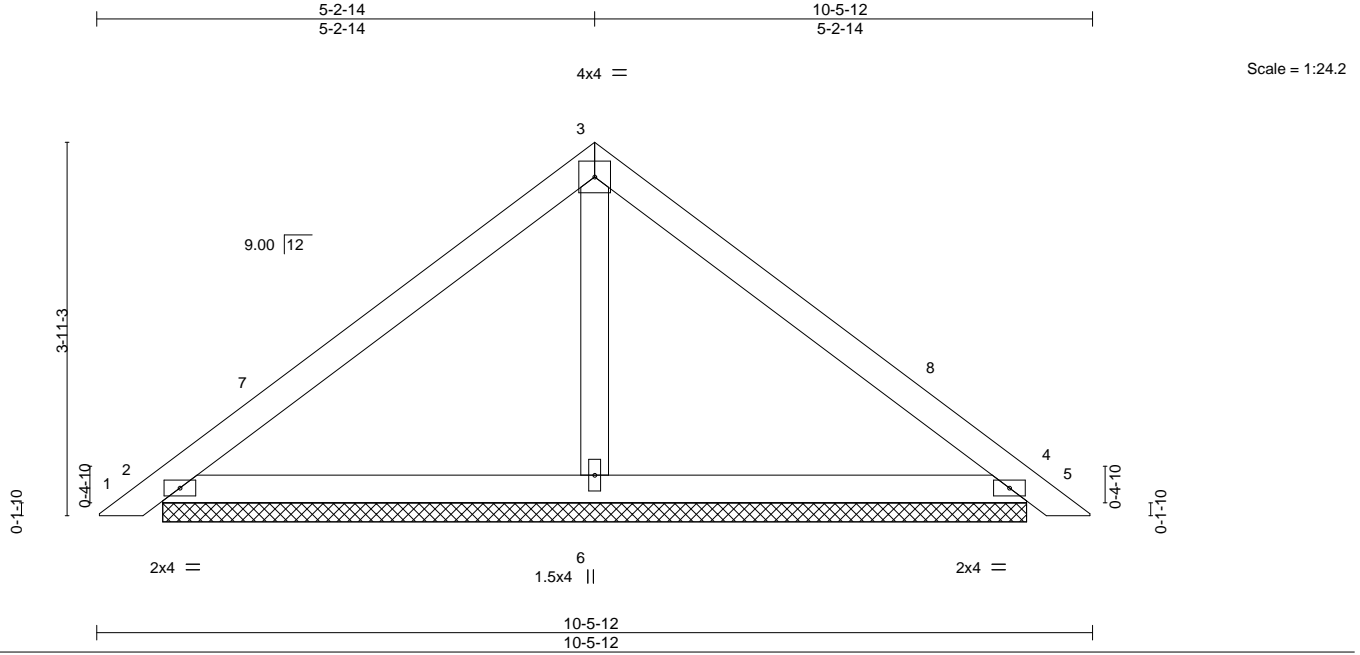

LOADING (psf)	SPACING-	CSI.	DEFL.	PLATES	GRIP
TCLL (roof) 20.0	2-0-0	TC 0.24	in (loc) l/defl L/d	MT20	244/190
Snow (Pf/Pg) 11.6/15.0	Plate Grip DOL 1.15	BC 0.15	Vert(LL) 0.01 5 n/r 120		
TCDL 10.0	Lumber DOL 1.15	WB 0.06	Vert(CT) 0.01 5 n/r 120		
BCLL 0.0 *	Rep Stress Incr YES	Matrix-S	Horz(CT) 0.00 4 n/a n/a		
BCDL 10.0	Code IRC2018/TPI2014			Weight: 38 lb	FT = 20%

LUMBER-	BRACING-
TOP CHORD 2x4 SP No.1	TOP CHORD Sheathed or 6-0-0 oc purlins.
BOT CHORD 2x4 SP No.1	BOT CHORD Rigid ceiling directly applied or 10-0-0 oc bracing.
OTHERS 2x4 SP No.3	

REACTIONS. (size) 2=9-1-2, 4=9-1-2, 6=9-1-2
 Max Horz 2=74(LC 11)
 Max Uplift 2=-26(LC 12), 4=-26(LC 12)
 Max Grav 2=216(LC 2), 4=216(LC 2), 6=348(LC 2)

FORCES. (lb) - Max. Comp./Max. Ten. - All forces 250 (lb) or less except when shown.

- NOTES-**
- Unbalanced roof live loads have been considered for this design.
 - Wind: ASCE 7-16; Vult=130mph (3-second gust) Vasd=103mph; TCDL=6.0psf; BCDL=6.0psf; h=12ft; B=45ft; L=24ft; eave=4ft; Cat. II; Exp B; Enclosed; MWFRS (directional); cantilever left and right exposed; end vertical left and right exposed; Lumber DOL=1.60 plate grip DOL=1.60
 - TCLL: ASCE 7-16; Pr=20.0 psf (roof LL: Lum DOL=1.15 Plate DOL=1.15); Pg=15.0 psf; Pf=11.6 psf (Lum DOL=1.15 Plate DOL=1.15); Is=1.0; Rough Cat B; Partially Exp.; Ce=1.0; Cs=1.00; Ct=1.10
 - Unbalanced snow loads have been considered for this design.
 - This truss has been designed for greater of min roof live load of 12.0 psf or 1.00 times flat roof load of 11.6 psf on overhangs non-concurrent with other live loads.
 - Gable requires continuous bottom chord bearing.
 - This truss has been designed for a 10.0 psf bottom chord live load nonconcurrent with any other live loads.
 - * This truss has been designed for a live load of 20.0psf on the bottom chord in all areas where a rectangle 3-6-0 tall by 2-0-0 wide will fit between the bottom chord and any other members.
 - Provide mechanical connection (by others) of truss to bearing plate capable of withstanding 100 lb uplift at joint(s) 2, 4.
 - This truss is designed in accordance with the 2018 International Residential Code sections R502.11.1 and R802.10.2 and referenced standard ANSI/TPI 1.
 - See Standard Industry Piggyback Truss Connection Detail for Connection to base truss as applicable, or consult qualified building designer.

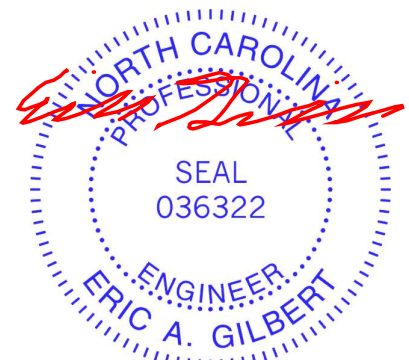

May 19, 2020

Job	Truss	Truss Type	Qty	Ply	RICHARDSON	E14419872
P20-04027	PB05	Piggyback	1	1	Job Reference (optional)	

Longleaf Truss Company,

West End, NC - 27376,

8.330 s Mar 23 2020 MiTek Industries, Inc. Tue May 19 07:20:38 2020 Page 1

ID:gkUVx24QO5glBKvEjRcThWzF1?4-DLPQBfyBk7cDNkH9vnnndMKM4pIBkH8yVQ2H0IUzF?pd

2-0-12
2-0-12

4-1-9
2-0-12

Scale = 1:9.8

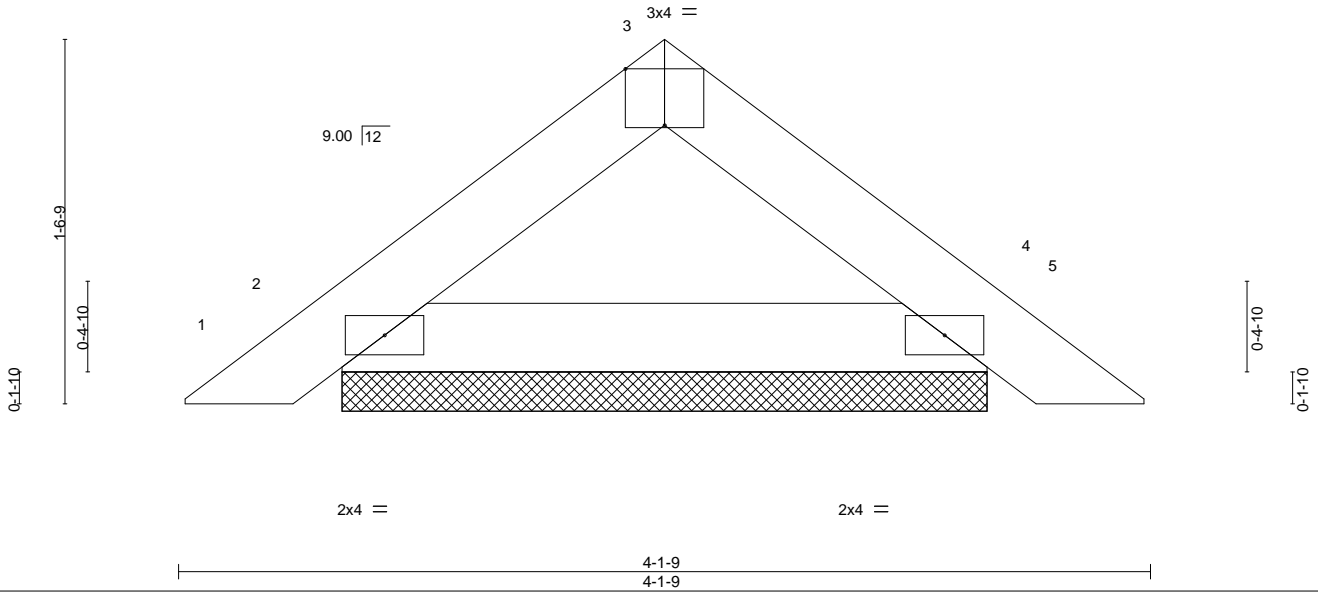

Plate Offsets (X,Y)-- [3:0-2-0,Edge]

LOADING (psf)	SPACING-	CSI.	DEFL.	in	(loc)	l/defl	L/d	PLATES	GRIP
TCLL (roof) 20.0	2-0-0	TC 0.02	Vert(LL)	0.00	4	n/r	120	MT20	244/190
Snow (Pf/Pg) 11.6/15.0	Plate Grip DOL 1.15	BC 0.06	Vert(CT)	0.00	4	n/r	120		
TCDL 10.0	Lumber DOL 1.15	WB 0.00	Horz(CT)	0.00	4	n/a	n/a		
BCLL 0.0 *	Rep Stress Incr YES	Matrix-P							
BCDL 10.0	Code IRC2018/TPI2014							Weight: 12 lb	FT = 20%

LUMBER-
TOP CHORD 2x4 SP No.1
BOT CHORD 2x4 SP No.1

BRACING-
TOP CHORD Sheathed or 4-1-9 oc purlins.
BOT CHORD Rigid ceiling directly applied or 10-0-0 oc bracing.

REACTIONS. (size) 2=2-8-14, 4=2-8-14
Max Horz 2=-27(LC 10)
Max Uplift 2=-11(LC 12), 4=-11(LC 12)
Max Grav 2=136(LC 2), 4=136(LC 2)

FORCES. (lb) - Max. Comp./Max. Ten. - All forces 250 (lb) or less except when shown.

NOTES-

- 1) Unbalanced roof live loads have been considered for this design.
- 2) Wind: ASCE 7-16; Vult=130mph (3-second gust) Vasd=103mph; TCDL=6.0psf; BCDL=6.0psf; h=12ft; B=45ft; L=24ft; eave=4ft; Cat. II; Exp B; Enclosed; MWFRS (directional); cantilever left and right exposed ; end vertical left and right exposed; Lumber DOL=1.60 plate grip DOL=1.60
- 3) TCLL: ASCE 7-16; Pr=20.0 psf (roof LL: Lum DOL=1.15 Plate DOL=1.15); Pg=15.0 psf; Pf=11.6 psf (Lum DOL=1.15 Plate DOL=1.15); Is=1.0; Rough Cat B; Partially Exp.; Ce=1.0; Cs=1.00; Ct=1.10
- 4) Unbalanced snow loads have been considered for this design.
- 5) This truss has been designed for greater of min roof live load of 12.0 psf or 1.00 times flat roof load of 11.6 psf on overhangs non-concurrent with other live loads.
- 6) Gable requires continuous bottom chord bearing.
- 7) This truss has been designed for a 10.0 psf bottom chord live load nonconcurrent with any other live loads.
- 8) * This truss has been designed for a live load of 20.0psf on the bottom chord in all areas where a rectangle 3-6-0 tall by 2-0-0 wide will fit between the bottom chord and any other members.
- 9) Provide mechanical connection (by others) of truss to bearing plate capable of withstanding 100 lb uplift at joint(s) 2, 4.
- 10) This truss is designed in accordance with the 2018 International Residential Code sections R502.11.1 and R802.10.2 and referenced standard ANSI/TPI 1.
- 11) See Standard Industry Piggyback Truss Connection Detail for Connection to base truss as applicable, or consult qualified building designer.



May 19, 2020

WARNING - Verify design parameters and READ NOTES ON THIS AND INCLUDED MITEK REFERENCE PAGE MII-7473 rev. 10/03/2015 BEFORE USE.

Design valid for use only with MiTek® connectors. This design is based only upon parameters shown, and is for an individual building component, not a truss system. Before use, the building designer must verify the applicability of design parameters and properly incorporate this design into the overall building design. Bracing indicated is to prevent buckling of individual truss web and/or chord members only. Additional temporary and permanent bracing is always required for stability and to prevent collapse with possible personal injury and property damage. For general guidance regarding the fabrication, storage, delivery, erection and bracing of trusses and truss systems, see **ANSI/TPI1 Quality Criteria, DSB-89 and BCSI Building Component Safety Information** available from Truss Plate Institute, 218 N. Lee Street, Suite 312, Alexandria, VA 22314.

ENGINEERING BY
TRENCO
A MiTek Affiliate

818 Soundside Road
Edenton, NC 27932

Job	Truss	Truss Type	Qty	Ply	RICHARDSON	E14419873
P20-04027	PB06	Piggyback	1	1	Job Reference (optional)	

Longleaf Truss Company,

West End, NC - 27376,

8.330 s Mar 23 2020 MiTek Industries, Inc. Tue May 19 07:20:39 2020 Page 1
ID:gkUVx24QO5glBKvEjRcThWzFI?4-hYzoP?ypVQk3?usLTUlsvYvFZ8Xz0bCffi1ZHwzF?pc

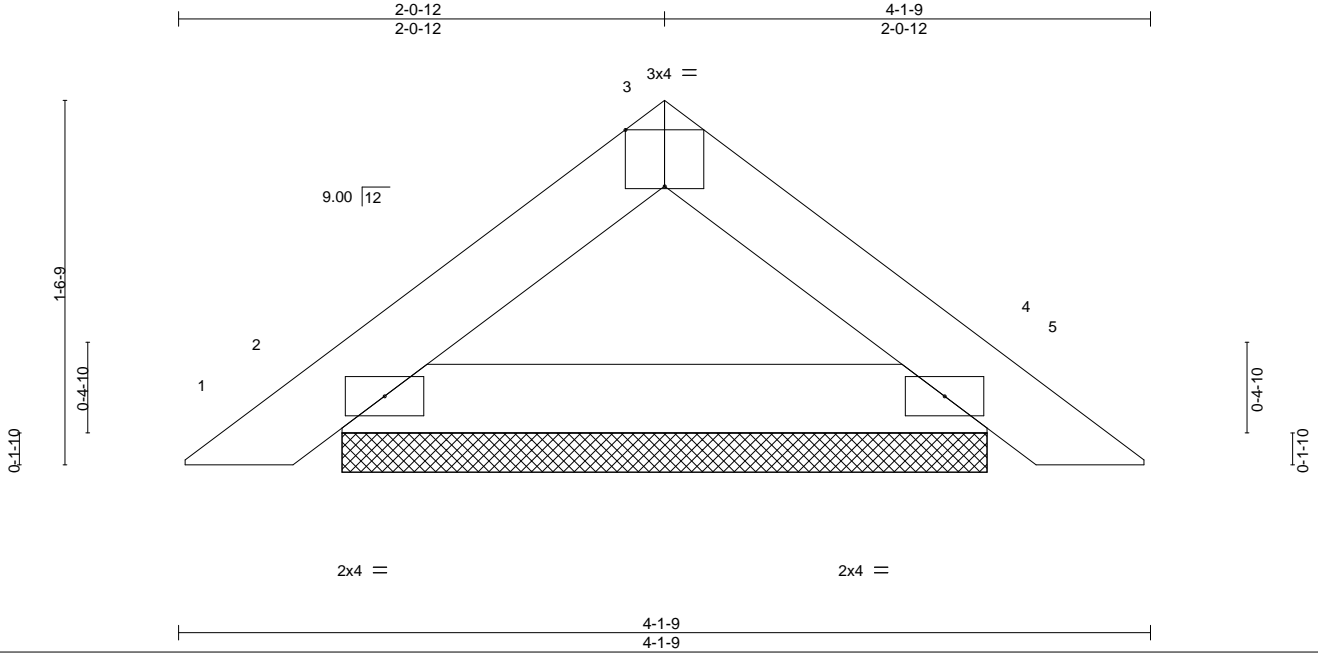

Scale = 1:9.8

Plate Offsets (X,Y)-- [3:0-2-0,Edge]

LOADING (psf)	SPACING-	CSI.	DEFL.	in	(loc)	l/defl	L/d	PLATES	GRIP
TCLL (roof) 20.0	2-0-0	TC 0.02	Vert(LL)	0.00	4	n/r	120	MT20	244/190
Snow (Pf/Pg) 11.6/15.0	Plate Grip DOL 1.15	BC 0.06	Vert(CT)	0.00	4	n/r	120		
TCDL 10.0	Lumber DOL 1.15	WB 0.00	Horz(CT)	0.00	4	n/a	n/a		
BCLL 0.0 *	Rep Stress Incr YES	Matrix-P							
BCDL 10.0	Code IRC2018/TPI2014							Weight: 12 lb	FT = 20%

LUMBER-
TOP CHORD 2x4 SP No.1
BOT CHORD 2x4 SP No.1

BRACING-
TOP CHORD Sheathed or 4-1-9 oc purlins.
BOT CHORD Rigid ceiling directly applied or 10-0-0 oc bracing.

REACTIONS. (size) 2=2-8-14, 4=2-8-14
Max Horz 2=-27(LC 10)
Max Uplift 2=-11(LC 12), 4=-11(LC 12)
Max Grav 2=136(LC 2), 4=136(LC 2)

FORCES. (lb) - Max. Comp./Max. Ten. - All forces 250 (lb) or less except when shown.

NOTES-

- Unbalanced roof live loads have been considered for this design.
- Wind: ASCE 7-16; Vult=130mph (3-second gust) Vasd=103mph; TCDL=6.0psf; BCDL=6.0psf; h=12ft; B=45ft; L=24ft; eave=4ft; Cat. II; Exp B; Enclosed; MWFRS (directional); cantilever left and right exposed ; end vertical left and right exposed; Lumber DOL=1.60 plate grip DOL=1.60
- TCLL: ASCE 7-16; Pr=20.0 psf (roof LL: Lum DOL=1.15 Plate DOL=1.15); Pg=15.0 psf; Pf=11.6 psf (Lum DOL=1.15 Plate DOL=1.15); Is=1.0; Rough Cat B; Partially Exp.; Ce=1.0; Cs=1.00; Ct=1.10
- Unbalanced snow loads have been considered for this design.
- This truss has been designed for greater of min roof live load of 12.0 psf or 1.00 times flat roof load of 11.6 psf on overhangs non-concurrent with other live loads.
- Gable requires continuous bottom chord bearing.
- This truss has been designed for a 10.0 psf bottom chord live load nonconcurrent with any other live loads.
- * This truss has been designed for a live load of 20.0psf on the bottom chord in all areas where a rectangle 3-6-0 tall by 2-0-0 wide will fit between the bottom chord and any other members.
- Provide mechanical connection (by others) of truss to bearing plate capable of withstanding 100 lb uplift at joint(s) 2, 4.
- This truss is designed in accordance with the 2018 International Residential Code sections R502.11.1 and R802.10.2 and referenced standard ANSI/TPI 1.
- See Standard Industry Piggyback Truss Connection Detail for Connection to base truss as applicable, or consult qualified building designer.

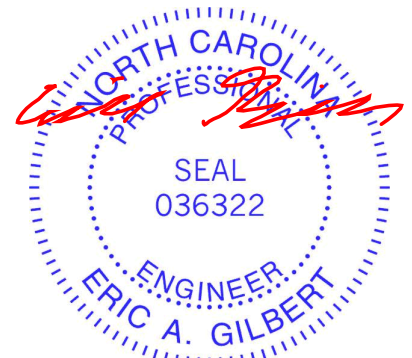

May 19, 2020

WARNING - Verify design parameters and READ NOTES ON THIS AND INCLUDED MITEK REFERENCE PAGE MII-7473 rev. 10/03/2015 BEFORE USE.

Design valid for use only with MiTek® connectors. This design is based only upon parameters shown, and is for an individual building component, not a truss system. Before use, the building designer must verify the applicability of design parameters and properly incorporate this design into the overall building design. Bracing indicated is to prevent buckling of individual truss web and/or chord members only. Additional temporary and permanent bracing is always required for stability and to prevent collapse with possible personal injury and property damage. For general guidance regarding the fabrication, storage, delivery, erection and bracing of trusses and truss systems, see **ANSI/TPI1 Quality Criteria, DSB-89 and BCSI Building Component Safety Information** available from Truss Plate Institute, 218 N. Lee Street, Suite 312, Alexandria, VA 22314.



818 Soundside Road
Edenton, NC 27932

Job	Truss	Truss Type	Qty	Ply	RICHARDSON	E14419874
P20-04027	PB07	Piggyback	1	1	Job Reference (optional)	

Longleaf Truss Company,

West End, NC - 27376,

8.330 s Mar 23 2020 MiTek Industries, Inc. Tue May 19 07:20:40 2020 Page 1

ID: gkUVx24QO5gIBKvEjRcThWzFI?4-AkXAclZRGkswd2RX0Cp5RIRQxYuoI2CouMm6pNzF?pb

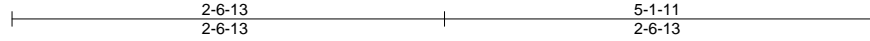

4x4 =

Scale = 1:13.7

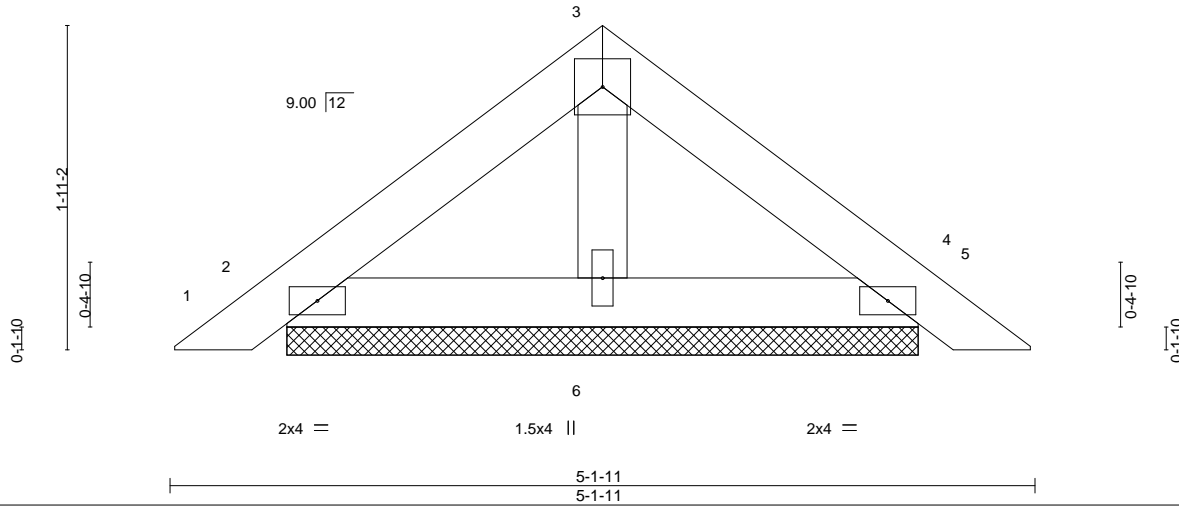

LOADING (psf)	SPACING-	CSI.	DEFL.	in (loc)	l/defl	L/d	PLATES	GRIP
TCLL (roof) 20.0	2-0-0	TC 0.04	Vert(LL)	0.00	4	n/r	MT20	244/190
Snow (Pf/Pg) 11.6/15.0	Plate Grip DOL 1.15	BC 0.03	Vert(CT)	0.00	5	n/r		
TCDL 10.0	Lumber DOL 1.15	WB 0.02	Horz(CT)	0.00	4	n/a		
BCLL 0.0 *	Rep Stress Incr YES	Matrix-P						
BCDL 10.0	Code IRC2018/TPI2014						Weight: 17 lb	FT = 20%

LUMBER-

TOP CHORD 2x4 SP No.1
 BOT CHORD 2x4 SP No.1
 OTHERS 2x4 SP No.3

BRACING-

TOP CHORD Sheathed or 5-1-11 oc purlins.
 BOT CHORD Rigid ceiling directly applied or 10-0-0 oc bracing.

REACTIONS.

(size) 2=3-9-0, 4=3-9-0, 6=3-9-0
 Max Horz 2=-34(LC 10)
 Max Uplift 2=-23(LC 12), 4=-23(LC 12)
 Max Grav 2=115(LC 17), 4=115(LC 18), 6=125(LC 2)

FORCES. (lb) - Max. Comp./Max. Ten. - All forces 250 (lb) or less except when shown.

NOTES-

- Unbalanced roof live loads have been considered for this design.
- Wind: ASCE 7-16; Vult=130mph (3-second gust) Vasd=103mph; TCDL=6.0psf; BCDL=6.0psf; h=12ft; B=45ft; L=24ft; eave=4ft; Cat. II; Exp B; Enclosed; MWFRS (directional); cantilever left and right exposed; end vertical left and right exposed; Lumber DOL=1.60 plate grip DOL=1.60
- TCLL: ASCE 7-16; Pr=20.0 psf (roof LL: Lum DOL=1.15 Plate DOL=1.15); Pg=15.0 psf; Pf=11.6 psf (Lum DOL=1.15 Plate DOL=1.15); Is=1.0; Rough Cat B; Partially Exp.; Ce=1.0; Cs=1.00; Ct=1.10
- Unbalanced snow loads have been considered for this design.
- This truss has been designed for greater of min roof live load of 12.0 psf or 1.00 times flat roof load of 11.6 psf on overhangs non-concurrent with other live loads.
- Gable requires continuous bottom chord bearing.
- This truss has been designed for a 10.0 psf bottom chord live load nonconcurrent with any other live loads.
- * This truss has been designed for a live load of 20.0psf on the bottom chord in all areas where a rectangle 3-6-0 tall by 2-0-0 wide will fit between the bottom chord and any other members.
- Provide mechanical connection (by others) of truss to bearing plate capable of withstanding 100 lb uplift at joint(s) 2, 4.
- This truss is designed in accordance with the 2018 International Residential Code sections R502.11.1 and R802.10.2 and referenced standard ANSI/TPI 1.
- See Standard Industry Piggyback Truss Connection Detail for Connection to base truss as applicable, or consult qualified building designer.



May 19, 2020

WARNING - Verify design parameters and READ NOTES ON THIS AND INCLUDED MITEK REFERENCE PAGE MII-7473 rev. 10/03/2015 BEFORE USE.

Design valid for use only with MiTek® connectors. This design is based only upon parameters shown, and is for an individual building component, not a truss system. Before use, the building designer must verify the applicability of design parameters and properly incorporate this design into the overall building design. Bracing indicated is to prevent buckling of individual truss web and/or chord members only. Additional temporary and permanent bracing is always required for stability and to prevent collapse with possible personal injury and property damage. For general guidance regarding the fabrication, storage, delivery, erection and bracing of trusses and truss systems, see **ANSI/TPI1 Quality Criteria, DSB-89 and BCSI Building Component Safety Information** available from Truss Plate Institute, 218 N. Lee Street, Suite 312, Alexandria, VA 22314.



818 Soundside Road
 Edenton, NC 27932

Job P20-04027	Truss PB08	Truss Type Piggyback	Qty 4	Ply 1	RICHARDSON	E14419875
------------------	---------------	-------------------------	----------	----------	------------	-----------

Longleaf Truss Company, West End, N.C.

8.330 s Apr 21 2020 MiTek Industries, Inc. Tue May 19 08:53:19 2020 Page 1
 ID: gkUVx24QO5glBKvEjRcThWzF1?4-AM6xglRXwUwxd1Jmjmpos4BZEV7F1D8MepG5KzF?L_

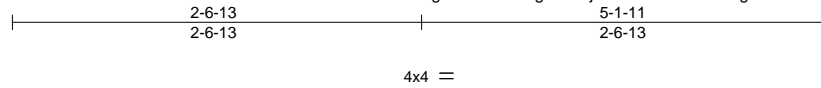

Scale = 1:14.5

LOADING (psf)	SPACING-	CSI.	DEFL.	PLATES	GRIP
TCLL (roof) 20.0	2-0-0	TC 0.04	in (loc) l/defl L/d	MT20	244/190
Snow (Pf/Pg) 11.6/15.0	Plate Grip DOL 1.15	BC 0.03	Vert(LL) n/a - n/a 999		
TCDL 10.0	Lumber DOL 1.15	WB 0.01	Vert(CT) n/a - n/a 999		
BCLL 0.0 *	Rep Stress Incr YES	Matrix-P	Horz(CT) 0.00 5 n/a n/a		
BCDL 10.0	Code IRC2018/TPI2014			Weight: 17 lb	FT = 20%

LUMBER-

TOP CHORD 2x4 SP No.1
 BOT CHORD 2x4 SP No.1
 OTHERS 2x4 SP No.3

BRACING-

TOP CHORD Sheathed or 5-1-11 oc purlins.
 BOT CHORD Rigid ceiling directly applied or 10-0-0 oc bracing.

REACTIONS.

(size) 1=5-1-11, 5=5-1-11, 2=5-1-11, 4=5-1-11, 6=5-1-11
 Max Horz 1=34(LC 10)
 Max Uplift 1=51(LC 24), 5=35(LC 25), 2=32(LC 12), 4=32(LC 12)
 Max Grav 1=24(LC 9), 5=20(LC 12), 2=171(LC 24), 4=166(LC 18), 6=117(LC 7)

FORCES. (lb) - Maximum Compression/Maximum Tension

TOP CHORD 1-2=-40/66, 2-3=-59/17, 3-4=-58/17, 4-5=-10/38
 BOT CHORD 2-6=-10/20, 4-6=-10/20
 WEBS 3-6=-68/2

NOTES-

- Unbalanced roof live loads have been considered for this design.
- Wind: ASCE 7-16; Vult=130mph (3-second gust) Vasd=103mph; TCDL=6.0psf; BCDL=6.0psf; h=12ft; B=45ft; L=24ft; eave=4ft; Cat. II; Exp B; Enclosed; MWFRS (directional); cantilever left and right exposed; end vertical left and right exposed; Lumber DOL=1.60 plate grip DOL=1.60
- TCLL: ASCE 7-16; Pr=20.0 psf (roof LL: Lum DOL=1.15 Plate DOL=1.15); Pg=15.0 psf; Pf=11.6 psf (Lum DOL=1.15 Plate DOL=1.15); Is=1.0; Rough Cat B; Partially Exp.; Ce=1.0; Cs=1.00; Ct=1.10
- Unbalanced snow loads have been considered for this design.
- Gable requires continuous bottom chord bearing.
- This truss has been designed for a 10.0 psf bottom chord live load nonconcurrent with any other live loads.
- * This truss has been designed for a live load of 20.0psf on the bottom chord in all areas where a rectangle 3-6-0 tall by 2-0-0 wide will fit between the bottom chord and any other members.
- Provide mechanical connection (by others) of truss to bearing plate capable of withstanding 51 lb uplift at joint 1, 35 lb uplift at joint 5, 32 lb uplift at joint 2 and 32 lb uplift at joint 4.
- This truss is designed in accordance with the 2018 International Residential Code sections R502.11.1 and R802.10.2 and referenced standard ANSI/TPI 1.
- See Standard Industry Piggyback Truss Connection Detail for Connection to base truss as applicable, or consult qualified building designer.



May 19, 2020

WARNING - Verify design parameters and READ NOTES ON THIS AND INCLUDED MITEK REFERENCE PAGE MII-7473 rev. 10/03/2015 BEFORE USE.

Design valid for use only with MiTek® connectors. This design is based only upon parameters shown, and is for an individual building component, not a truss system. Before use, the building designer must verify the applicability of design parameters and properly incorporate this design into the overall building design. Bracing indicated is to prevent buckling of individual truss web and/or chord members only. Additional temporary and permanent bracing is always required for stability and to prevent collapse with possible personal injury and property damage. For general guidance regarding the fabrication, storage, delivery, erection and bracing of trusses and truss systems, see **ANSI/TPI1 Quality Criteria, DSB-89 and BCSI Building Component Safety Information** available from Truss Plate Institute, 218 N. Lee Street, Suite 312, Alexandria, VA 22314.



818 Soundside Road
 Edenton, NC 27932

Job P20-04027	Truss PB09	Truss Type Piggyback	Qty 1	Ply 2	RICHARDSON	E14419876
------------------	---------------	-------------------------	----------	----------	------------	-----------

Longleaf Truss Company, West End, N.C.

8.330 s Apr 21 2020 MiTek Industries, Inc. Tue May 19 08:53:31 2020 Page 1
ID: gkUVx24QO5glBKvEjRcThWzF1?4-pgqTBPb35AQE3tEfTE1aHOaFs4b73Tlv7VjvVdzF?Ko

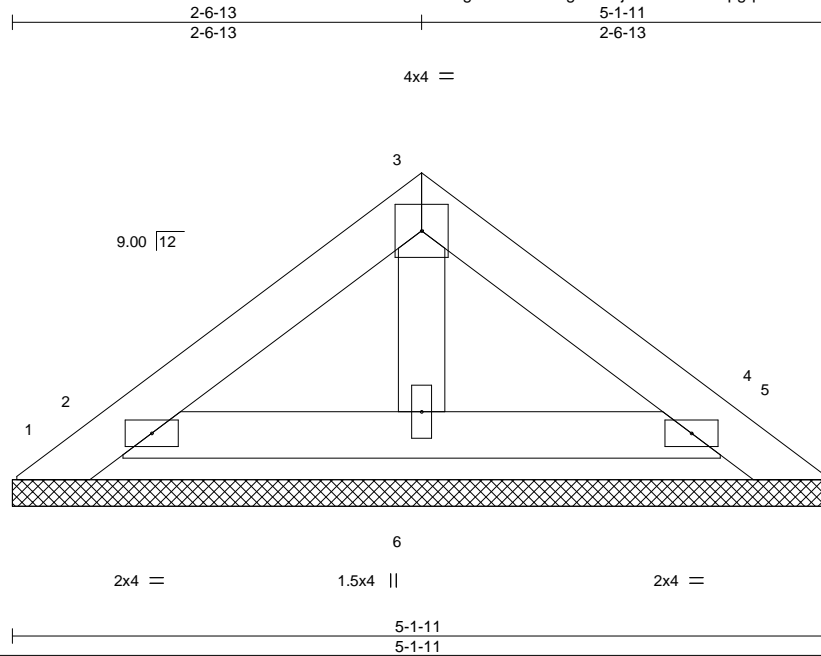

Scale = 1:14.5

LOADING (psf)	SPACING-	CSI.	DEFL.	PLATES	GRIP
TCLL (roof) 20.0	2-0-0	TC 0.02	in (loc) l/defl L/d	MT20	244/190
Snow (Pf/Pg) 11.6/15.0	Plate Grip DOL 1.15	BC 0.01	Vert(LL) n/a - n/a 999		
TCDL 10.0	Lumber DOL 1.15	WB 0.01	Vert(CT) n/a - n/a 999		
BCLL 0.0 *	Rep Stress Incr YES	Matrix-P	Horz(CT) 0.00 5 n/a n/a		
BCDL 10.0	Code IRC2018/TPI2014			Weight: 34 lb	FT = 20%

LUMBER-

TOP CHORD 2x4 SP No.1
BOT CHORD 2x4 SP No.1
OTHERS 2x4 SP No.3

BRACING-

TOP CHORD Sheathed or 5-1-11 oc purlins.
BOT CHORD Rigid ceiling directly applied or 10-0-0 oc bracing.

REACTIONS.

(size) 1=5-1-11, 5=5-1-11, 2=5-1-11, 4=5-1-11, 6=5-1-11
Max Horz 1=34(LC 10)
Max Uplift 1=51(LC 24), 5=35(LC 25), 2=32(LC 12), 4=32(LC 12)
Max Grav 1=24(LC 9), 5=20(LC 12), 2=171(LC 24), 4=166(LC 18), 6=117(LC 7)

FORCES. (lb) - Maximum Compression/Maximum Tension

TOP CHORD 1-2=-40/66, 2-3=-59/17, 3-4=-58/17, 4-5=-10/38
BOT CHORD 2-6=-10/20, 4-6=-10/20
WEBS 3-6=-68/2

NOTES-

- 2-ply truss to be connected together with 10d (0.131"x3") nails as follows:
Top chords connected as follows: 2x4 - 1 row at 0-9-0 oc.
Bottom chords connected as follows: 2x4 - 1 row at 0-9-0 oc.
- All loads are considered equally applied to all plies, except if noted as front (F) or back (B) face in the LOAD CASE(S) section. Ply to ply connections have been provided to distribute only loads noted as (F) or (B), unless otherwise indicated.
- Unbalanced roof live loads have been considered for this design.
- Wind: ASCE 7-16; Vult=130mph (3-second gust) Vasd=103mph; TC DL=6.0psf; BC DL=6.0psf; h=12ft; B=45ft; L=24ft; eave=4ft; Cat. II; Exp B; Enclosed; MWFRS (directional); cantilever left and right exposed; end vertical left and right exposed; Lumber DOL=1.60 plate grip DOL=1.60
- TCLL: ASCE 7-16; Pr=20.0 psf (roof LL: Lum DOL=1.15 Plate DOL=1.15); Pg=15.0 psf; Pf=11.6 psf (Lum DOL=1.15 Plate DOL=1.15); Is=1.0; Rough Cat B; Partially Exp.; Ce=1.0; Cs=1.00; Ct=1.10
- Unbalanced snow loads have been considered for this design.
- Gable requires continuous bottom chord bearing.
- This truss has been designed for a 10.0 psf bottom chord live load nonconcurrent with any other live loads.
- * This truss has been designed for a live load of 20.0psf on the bottom chord in all areas where a rectangle 3-6-0 tall by 2-0-0 wide will fit between the bottom chord and any other members.
- Provide mechanical connection (by others) of truss to bearing plate capable of withstanding 51 lb uplift at joint 1, 35 lb uplift at joint 5, 32 lb uplift at joint 2 and 32 lb uplift at joint 4.
- This truss is designed in accordance with the 2018 International Residential Code sections R502.11.1 and R802.10.2 and referenced standard ANSI/TPI 1.
- See Standard Industry Piggyback Truss Connection Detail for Connection to base truss as applicable, or consult qualified building designer.



May 19, 2020

WARNING - Verify design parameters and READ NOTES ON THIS AND INCLUDED MITEK REFERENCE PAGE MII-7473 rev. 10/03/2015 BEFORE USE.

Design valid for use only with MiTek® connectors. This design is based only upon parameters shown, and is for an individual building component, not a truss system. Before use, the building designer must verify the applicability of design parameters and properly incorporate this design into the overall building design. Bracing indicated is to prevent buckling of individual truss web and/or chord members only. Additional temporary and permanent bracing is always required for stability and to prevent collapse with possible personal injury and property damage. For general guidance regarding the fabrication, storage, delivery, erection and bracing of trusses and truss systems, see **ANSI/TPI1 Quality Criteria, DSB-89 and BCSI Building Component Safety Information** available from Truss Plate Institute, 218 N. Lee Street, Suite 312, Alexandria, VA 22314.



818 Soundside Road
Edenton, NC 27932

Job	Truss	Truss Type	Qty	Ply	RICHARDSON	E14419877
P20-04027	T01	Piggyback Base Supported Gable	1	1	Job Reference (optional)	

Longleaf Truss Company, West End, NC - 27376,

8.330 s Mar 23 2020 MiTek Industries, Inc. Tue May 19 07:20:44 2020 Page 1

ID: gkUVx24QO5glBKvEjRcThWzF1?4-2VmhSiOyKzMM5fkJF2u1cbc2j9EdhoCOp_kKy8zF?pX

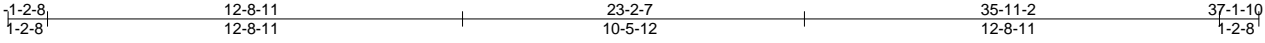

Scale = 1:70.6

Plate Offsets (X,Y)-- [10:0-4-8,0-2-4], [16:0-3-0,0-2-0]

LOADING (psf)	SPACING-	CSI.	DEFL.	in (loc)	l/defl	L/d	PLATES	GRIP
TCLL (roof) 20.0	2-0-0	TC 0.25	Vert(LL)	-0.01	25	n/r	MT20	244/190
Snow (Pf/Pg) 16.5/15.0	Plate Grip DOL 1.15	BC 0.10	Vert(CT)	-0.01	25	n/r		
TCDL 10.0	Lumber DOL 1.15	WB 0.21	Horz(CT)	-0.01	26	n/a		
BCLL 0.0 *	Rep Stress Incr YES	Matrix-R					Weight: 313 lb	FT = 20%
BCDL 10.0	Code IRC2018/TPI2014							

LUMBER-	BRACING-
TOP CHORD 2x4 SP No.1	TOP CHORD Sheathed or 6-0-0 oc purlins, except end verticals, and 2-0-0 oc purlins (6-0-0 max.): 10-16.
BOT CHORD 2x4 SP No.1	BOT CHORD Rigid ceiling directly applied or 6-0-0 oc bracing.
WEBS 2x4 SP No.3	WEBS 1 Row at midpt 16-33, 15-34, 14-36, 13-37, 12-39, 11-40, 9-41, 18-32
OTHERS 2x4 SP No.3	

REACTIONS. All bearings 35-11-2.
 (lb) - Max Horz 47=254(LC 10)
 Max Uplift All uplift 100 lb or less at joint(s) 36, 39, 42, 43, 44, 45, 32, 31, 30, 29, 28 except 47=168(LC 10), 26=254(LC 11), 46=134(LC 11), 27=207(LC 10)
 Max Grav All reactions 250 lb or less at joint(s) 33, 34, 36, 37, 39, 40, 41, 42, 43, 44, 45, 32, 31, 30, 29, 28 except 47=283(LC 25), 26=331(LC 24), 46=260(LC 10), 27=317(LC 11)

FORCES. (lb) - Max. Comp./Max. Ten. - All forces 250 (lb) or less except when shown.
 TOP CHORD 9-10=-66/252, 16-18=-61/263

- NOTES-**
- Unbalanced roof live loads have been considered for this design.
 - Wind: ASCE 7-16; Vult=130mph (3-second gust) Vasd=103mph; TCDL=6.0psf; BCDL=6.0psf; h=12ft; B=45ft; L=36ft; eave=2ft; Cat. II; Exp B; Enclosed; MWFRS (directional); cantilever left and right exposed; end vertical left and right exposed; Lumber DOL=1.60 plate grip DOL=1.60
 - Truss designed for wind loads in the plane of the truss only. For studs exposed to wind (normal to the face), see Standard Industry Gable End Details as applicable, or consult qualified building designer as per ANSI/TPI 1.
 - TCLL: ASCE 7-16; Pr=20.0 psf (roof LL: Lum DOL=1.15 Plate DOL=1.15); Pg=15.0 psf; Pf=16.5 psf (Lum DOL=1.15 Plate DOL=1.15); Is=1.0; Rough Cat B; Partially Exp.; Ce=1.0; Cs=1.00; Ct=1.10, Lu=50-0-0; Min. flat roof snow load governs. Rain surcharge applied to all exposed surfaces with slopes less than 0.500/12 in accordance with IBC 1608.3.4.
 - Unbalanced snow loads have been considered for this design.
 - This truss has been designed for greater of min roof live load of 12.0 psf or 1.00 times flat roof load of 11.6 psf on overhangs non-concurrent with other live loads.
 - Provide adequate drainage to prevent water ponding.
 - All plates are 1.5x4 MT20 unless otherwise indicated.
 - Gable requires continuous bottom chord bearing.
 - Truss to be fully sheathed from one face or securely braced against lateral movement (i.e. diagonal web).
 - Gable studs spaced at 2-0-0 oc.
 - This truss has been designed for a 10.0 psf bottom chord live load nonconcurrent with any other live loads.
 - * This truss has been designed for a live load of 20.0psf on the bottom chord in all areas where a rectangle 3-6-0 tall by 2-0-0 wide will fit between the bottom chord and any other members.
 - Provide mechanical connection (by others) of truss to bearing plate capable of withstanding 100 lb uplift at joint(s) 36, 39, 42, 43, 44, 45, 32, 31, 30, 29, 28 except (jt=lb) 47=168, 26=254, 46=134, 27=207.
 - This truss is designed in accordance with the 2018 International Residential Code sections R502.11.1 and R802.10.2 and referenced standard ANSI/TPI 1.
 - Graphical purlin representation does not depict the size or the orientation of the purlin along the top and/or bottom chord.

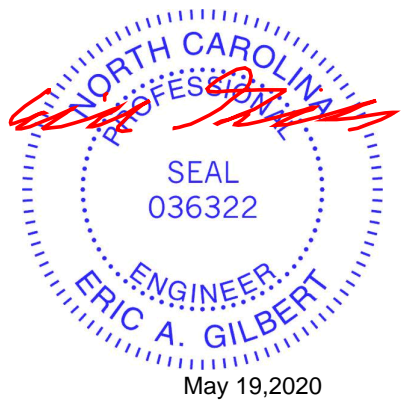

WARNING - Verify design parameters and READ NOTES ON THIS AND INCLUDED MITEK REFERENCE PAGE MII-7473 rev. 10/03/2015 BEFORE USE.

Design valid for use only with MiTek® connectors. This design is based only upon parameters shown, and is for an individual building component, not a truss system. Before use, the building designer must verify the applicability of design parameters and properly incorporate this design into the overall building design. Bracing indicated is to prevent buckling of individual truss web and/or chord members only. Additional temporary and permanent bracing is always required for stability and to prevent collapse with possible personal injury and property damage. For general guidance regarding the fabrication, storage, delivery, erection and bracing of trusses and truss systems, see **ANSI/TPI Quality Criteria, DSB-89 and BCSI Building Component Safety Information** available from Truss Plate Institute, 218 N. Lee Street, Suite 312, Alexandria, VA 22314.

ENGINEERING BY
TRENCO
 A MiTek Affiliate

818 Soundside Road
 Edenton, NC 27932

Job	Truss	Truss Type	Qty	Ply	RICHARDSON	E14419878
P20-04027	T01GE	Common Supported Gable	1	1	Job Reference (optional)	

Longleaf Truss Company,

West End, NC - 27376,

8.330 s Mar 23 2020 MiTek Industries, Inc. Tue May 19 07:20:47 2020 Page 1

ID: gkUVx24QO5glBkVejRcThWzF1?4-S4Sq4k2qdukxy7TuxARIDEEZVNGYU93qVxz_ZTzF?pU

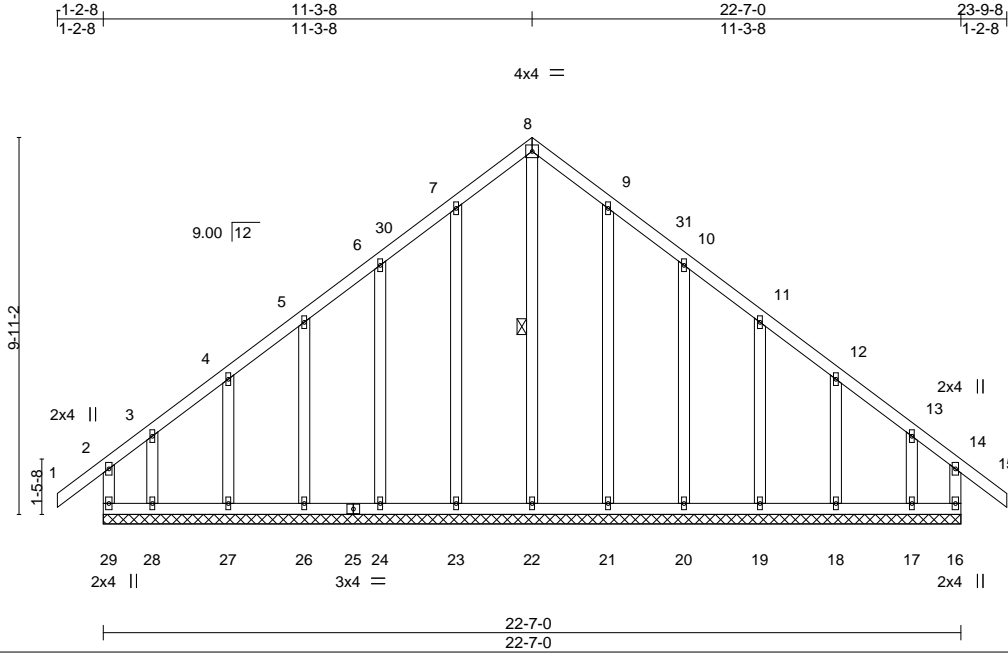

Scale = 1:60.7

LOADING (psf)	SPACING-	CSI.	DEFL.	PLATES	GRIP
TCLL (roof) 20.0	2-0-0	TC 0.21	in (loc) l/defl L/d	MT20	244/190
Snow (Pf/Pg) 11.6/15.0	Plate Grip DOL 1.15	BC 0.08	Vert(LL) -0.01 15 n/r 120		
TCDL 10.0	Lumber DOL 1.15	WB 0.20	Vert(CT) -0.01 15 n/r 120		
BCLL 0.0 *	Rep Stress Incr YES	Matrix-R	Horz(CT) -0.00 16 n/a n/a	Weight: 170 lb	FT = 20%
BCDL 10.0	Code IRC2018/TPI2014				

LUMBER-	BRACING-
TOP CHORD 2x4 SP No.1	TOP CHORD Sheathed or 6-0-0 oc purlins, except end verticals.
BOT CHORD 2x4 SP No.1	BOT CHORD Rigid ceiling directly applied or 6-0-0 oc bracing.
WEBS 2x4 SP No.3	WEBS 1 Row at midpt 8-22
OTHERS 2x4 SP No.3	

REACTIONS. All bearings 22-7-0.
 (lb) - Max Horz 29=220(LC 11)
 Max Uplift All uplift 100 lb or less at joint(s) 16, 23, 24, 26, 27, 21, 20, 19, 18, 17 except 29=-125(LC 10), 28=-101(LC 11)
 Max Grav All reactions 250 lb or less at joint(s) 29, 16, 23, 24, 26, 27, 28, 21, 20, 19, 18, 17 except 22=265(LC 12)

FORCES. (lb) - Max. Comp./Max. Ten. - All forces 250 (lb) or less except when shown.

NOTES-

- Unbalanced roof live loads have been considered for this design.
- Wind: ASCE 7-16; Vult=130mph (3-second gust) Vasd=103mph; TCDL=6.0psf; BCDL=6.0psf; h=12ft; B=45ft; L=24ft; eave=2ft; Cat. II; Exp B; Enclosed; MWFRS (directional); cantilever left and right exposed ; end vertical left and right exposed; Lumber DOL=1.60 plate grip DOL=1.60
- Truss designed for wind loads in the plane of the truss only. For studs exposed to wind (normal to the face), see Standard Industry Gable End Details as applicable, or consult qualified building designer as per ANSI/TPI 1.
- TCLL: ASCE 7-16; Pr=20.0 psf (roof LL: Lum DOL=1.15 Plate DOL=1.15); Pg=15.0 psf; Pf=11.6 psf (Lum DOL=1.15 Plate DOL=1.15); Is=1.0; Rough Cat B; Partially Exp.; Ce=1.0; Cs=1.00; Ct=1.10
- Unbalanced snow loads have been considered for this design.
- This truss has been designed for greater of min roof live load of 12.0 psf or 1.00 times flat roof load of 11.6 psf on overhangs non-concurrent with other live loads.
- All plates are 1.5x4 MT20 unless otherwise indicated.
- Gable requires continuous bottom chord bearing.
- Truss to be fully sheathed from one face or securely braced against lateral movement (i.e. diagonal web).
- Gable studs spaced at 2-0-0 oc.
- This truss has been designed for a 10.0 psf bottom chord live load nonconcurrent with any other live loads.
- * This truss has been designed for a live load of 20.0psf on the bottom chord in all areas where a rectangle 3-6-0 tall by 2-0-0 wide will fit between the bottom chord and any other members.
- Provide mechanical connection (by others) of truss to bearing plate capable of withstanding 100 lb uplift at joint(s) 16, 23, 24, 26, 27, 21, 20, 19, 18, 17 except (jt=lb) 29=125, 28=101.
- This truss is designed in accordance with the 2018 International Residential Code sections R502.11.1 and R802.10.2 and referenced standard ANSI/TPI 1.



May 19, 2020

WARNING - Verify design parameters and READ NOTES ON THIS AND INCLUDED MITEK REFERENCE PAGE MII-7473 rev. 10/03/2015 BEFORE USE.
 Design valid for use only with MiTek® connectors. This design is based only upon parameters shown, and is for an individual building component, not a truss system. Before use, the building designer must verify the applicability of design parameters and properly incorporate this design into the overall building design. Bracing indicated is to prevent buckling of individual truss web and/or chord members only. Additional temporary and permanent bracing is always required for stability and to prevent collapse with possible personal injury and property damage. For general guidance regarding the fabrication, storage, delivery, erection and bracing of trusses and truss systems, see **ANSI/TPI1 Quality Criteria, DSB-89 and BCSI Building Component Safety Information** available from Truss Plate Institute, 218 N. Lee Street, Suite 312, Alexandria, VA 22314.



Job	Truss	Truss Type	Qty	Ply	RICHARDSON	E14419880
P20-04027	T02	Piggyback Base	6	1	Job Reference (optional)	

Longleaf Truss Company, West End, NC - 27376, 8.330 s Mar 23 2020 MiTek Industries, Inc. Tue May 19 07:20:52 2020 Page 1

ID: gkUVx24Q05glBKvEjRcThWzFI?4-p2Fj7R6zRQMD3uLrjj1wwHxLUOUJZLeZeDhIFgz?pP

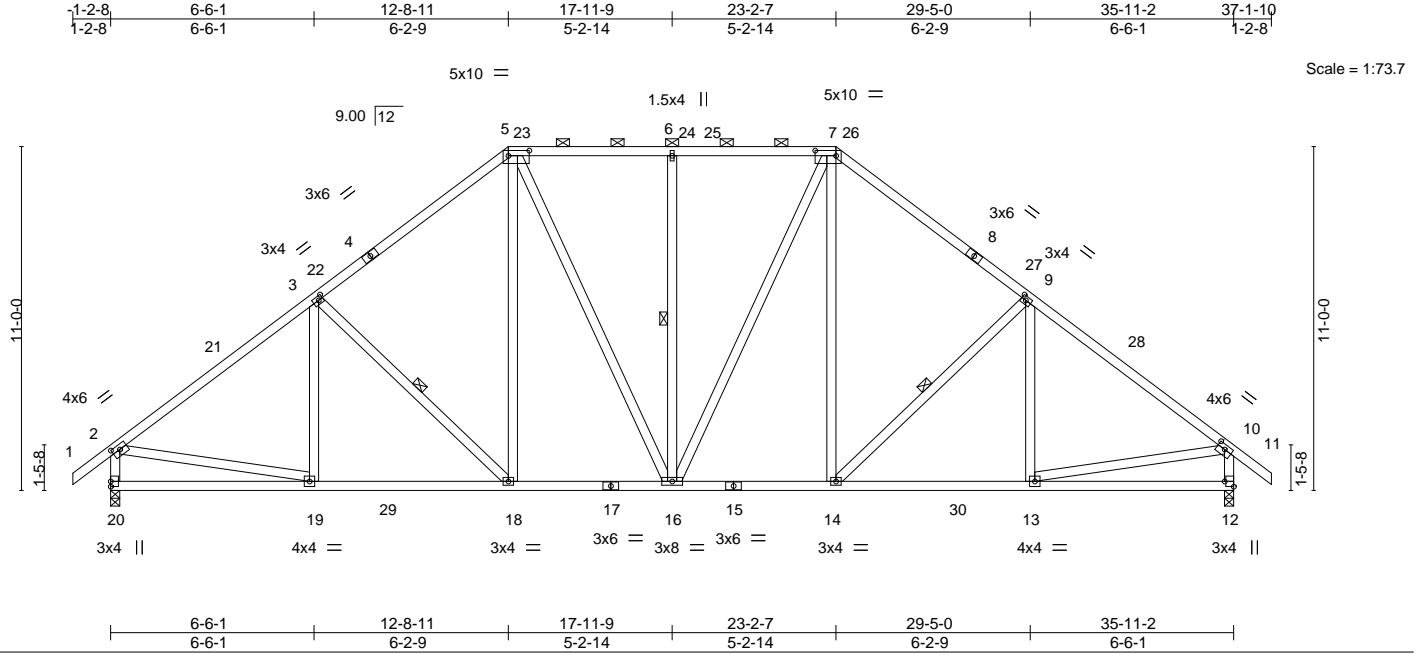

Plate Offsets (X,Y)-- [2:0-3-0,0-1-12], [3:0-1-12,0-1-8], [5:0-8-0,0-2-0], [7:0-8-0,0-2-0], [9:0-1-12,0-1-8], [10:0-3-0,0-1-12], [12:Edge,0-3-8]

LOADING (psf)	SPACING-	CSI.	DEFL.	PLATES	GRIP
TCLL (roof) 20.0	2-0-0	TC 0.52	in (loc) l/defl L/d	MT20	244/190
Snow (Pf/Pg) 16.5/15.0	Plate Grip DOL 1.15	BC 0.43	Vert(LL) -0.08 13-14 >999 240		
TCDL 10.0	Lumber DOL 1.15	WB 0.56	Vert(CT) -0.15 13-14 >999 180		
BCLL 0.0 *	Rep Stress Incr YES	Matrix-S	Horz(CT) 0.05 12 n/a n/a		
BCDL 10.0	Code IRC2018/TPI2014			Weight: 265 lb	FT = 20%

LUMBER-	BRACING-
TOP CHORD 2x4 SP No.1	TOP CHORD Sheathed or 4-3-13 oc purlins, except end verticals, and 2-0-0 oc purlins (5-2-5 max.): 5-7.
BOT CHORD 2x4 SP No.1	BOT CHORD Rigid ceiling directly applied or 10-0-0 oc bracing.
WEBS 2x4 SP No.3	WEBS 1 Row at midpt 3-18, 6-16, 9-14

REACTIONS. (size) 20=0-3-8, 12=0-3-8
 Max Horz 20=254(LC 11)
 Max Uplift 20=33(LC 12), 12=33(LC 12)
 Max Grav 20=1734(LC 24), 12=1734(LC 25)

FORCES. (lb) - Max. Comp./Max. Ten. - All forces 250 (lb) or less except when shown.
 TOP CHORD 2-3=-1962/49, 3-5=-1702/118, 5-6=-1387/128, 6-7=-1387/128, 7-9=-1702/118,
 9-10=-1962/49, 2-20=-1632/66, 10-12=-1632/66
 BOT CHORD 19-20=-193/342, 18-19=0/1649, 16-18=0/1378, 14-16=0/1317, 13-14=0/1483
 WEBS 3-18=-442/90, 5-18=0/545, 5-16=-30/396, 6-16=-491/59, 7-16=-30/396, 7-14=0/546,
 9-14=-442/90, 2-19=0/1387, 10-13=0/1390

- NOTES-**
- Unbalanced roof live loads have been considered for this design.
 - Wind: ASCE 7-16; Vult=130mph (3-second gust) Vasd=103mph; TC DL=6.0psf; BCDL=6.0psf; h=12ft; B=45ft; L=36ft; eave=5ft; Cat. II; Exp B; Enclosed; MWFRS (directional); cantilever left and right exposed; end vertical left and right exposed; Lumber DOL=1.60 plate grip DOL=1.60
 - TCLL: ASCE 7-16; Pr=20.0 psf (roof LL: Lum DOL=1.15 Plate DOL=1.15); Pg=15.0 psf; Pf=16.5 psf (Lum DOL=1.15 Plate DOL=1.15); Is=1.0; Rough Cat B; Partially Exp.; Ce=1.0; Cs=1.00; Ct=1.10, Lu=50-0-0; Min. flat roof snow load governs. Rain surcharge applied to all exposed surfaces with slopes less than 0.500/12 in accordance with IBC 1608.3.4.
 - Unbalanced snow loads have been considered for this design.
 - This truss has been designed for greater of min roof live load of 12.0 psf or 1.00 times flat roof load of 11.6 psf on overhangs non-concurrent with other live loads.
 - Provide adequate drainage to prevent water ponding.
 - This truss has been designed for a 10.0 psf bottom chord live load nonconcurrent with any other live loads.
 - * This truss has been designed for a live load of 20.0psf on the bottom chord in all areas where a rectangle 3-6-0 tall by 2-0-0 wide will fit between the bottom chord and any other members, with BCDL = 10.0psf.
 - Provide mechanical connection (by others) of truss to bearing plate capable of withstanding 100 lb uplift at joint(s) 20, 12.
 - This truss is designed in accordance with the 2018 International Residential Code sections R502.11.1 and R802.10.2 and referenced standard ANSI/TPI 1.
 - Graphical purlin representation does not depict the size or the orientation of the purlin along the top and/or bottom chord.



May 19, 2020

Job	Truss	Truss Type	Qty	Ply	RICHARDSON	E14419881
P20-04027	T03	Piggyback Base	5	1	Job Reference (optional)	

Longleaf Truss Company, West End, NC - 27376,

8.330 s Mar 23 2020 MiTek Industries, Inc. Tue May 19 07:20:56 2020 Page 1

ID: gkUVvX24QO5gIBKvEjRcThWzFI?4-ipVEzp9TVftfYfvcyZ6s5766?ATV4z9ZrfzORzF?pL

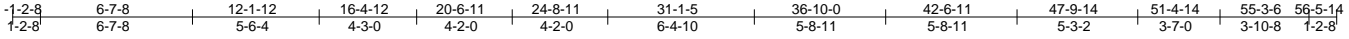

Scale = 1:100.4

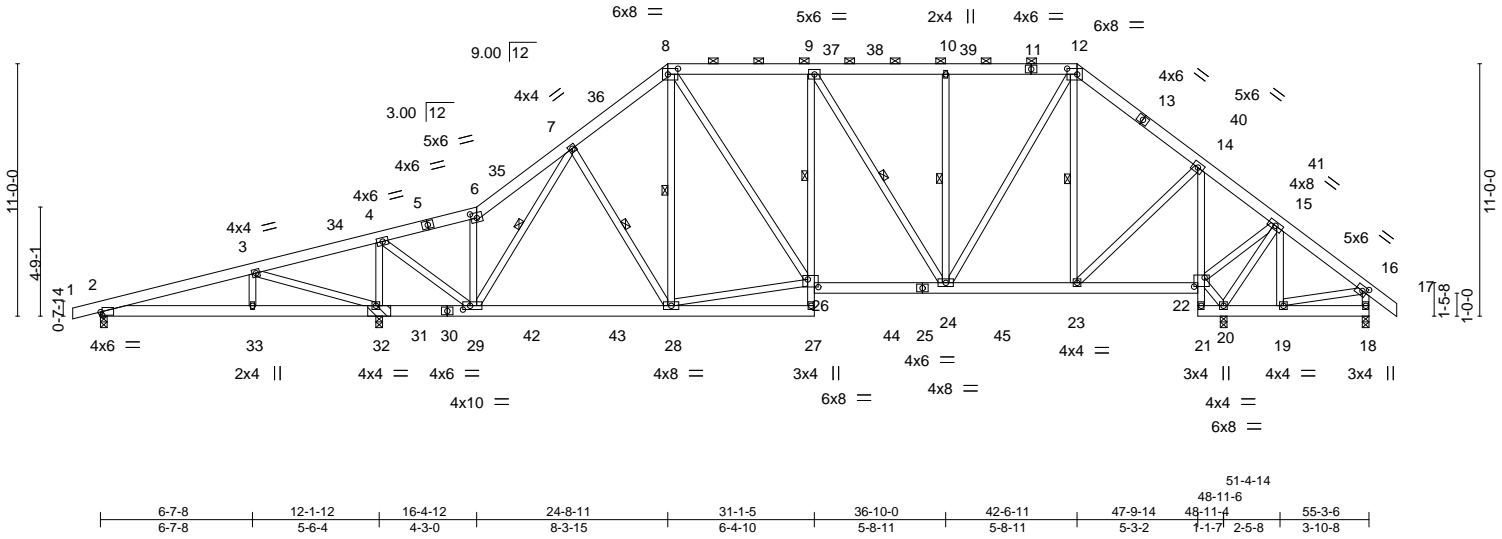

Plate Offsets (X,Y)-- [2:0-0-14,0-1-11], [6:0-3-0,0-2-12], [8:0-5-4,0-3-0], [12:0-5-4,0-3-0], [16:0-2-8,0-2-8], [22:0-5-8,0-4-12], [26:0-5-8,0-4-0], [29:0-3-12,0-2-0]

LOADING (psf)	SPACING-	CSI.	DEFL.	PLATES	GRIP
TCLL (roof) 20.0	2-0-0	TC 0.23	in (loc) l/defl L/d	MT20	244/190
Snow (Pf/Pg) 16.5/15.0	Plate Grip DOL 1.15	BC 0.74	Vert(LL) -0.08 28-29 >999 240		
TCDL 10.0	Lumber DOL 1.15	WB 0.86	Vert(CT) -0.14 28-29 >999 180		
BCLL 0.0 *	Rep Stress Incr YES	Matrix-S	Horz(CT) 0.04 20 n/a n/a		
BCDL 10.0	Code IRC2018/TPI2014			Weight: 492 lb	FT = 20%

LUMBER-	BRACING-
TOP CHORD 2x6 SP No.1	TOP CHORD Sheathed or 6-0-0 oc purlins, except end verticals, and 2-0-0 oc purlins (6-0-0 max.): 8-12.
BOT CHORD 2x6 SP No.1 *Except*	BOT CHORD Rigid ceiling directly applied or 6-0-0 oc bracing. Except:
9-27,14-21: 2x4 SP No.3	1 Row at midpt 9-26
WEBS 2x4 SP No.3	WEBS 1 Row at midpt 7-29, 7-28, 8-28, 9-24, 10-24, 12-23

REACTIONS. All bearings 0-3-8 except (jt=length) 32=0-4-0 (input: 0-3-8 + bearing block).
 (lb) - Max Horz 2=233(LC 11)
 Max Uplift All uplift 100 lb or less at joint(s) 2, 18, 32
 Max Grav All reactions 250 lb or less at joint(s) 18 except 2=345(LC 54), 32=2566(LC 24), 20=2054(LC 25)

FORCES. (lb) - Max. Comp./Max. Ten. - All forces 250 (lb) or less except when shown.
 TOP CHORD 2-3=-258/183, 3-4=0/1005, 4-6=-913/33, 6-7=-1114/107, 7-8=-1509/126, 8-9=-1604/114,
 9-10=-1417/116, 10-12=-1420/116, 12-14=-1170/109, 14-15=-255/66
 BOT CHORD 29-32=-894/73, 28-29=0/1232, 9-26=-252/148, 24-26=0/1685, 23-24=0/920,
 21-22=-259/0, 14-22=-1436/28
 WEBS 3-33=0/256, 3-32=-988/8, 4-32=-2072/40, 4-29=0/2176, 6-29=-587/90, 7-29=-601/0,
 26-28=0/1227, 8-26=0/755, 9-24=-404/0, 10-24=-487/66, 12-24=0/1062, 12-23=-516/5,
 14-23=0/1048, 20-22=-957/66, 15-22=0/868, 15-20=-967/0

- NOTES-**
- 2x6 SP No.1 bearing block 12" long at jt. 32 attached to front face with 3 rows of 10d (0.131"x3") nails spaced 3" o.c. 12 Total fasteners. User Defined Bearing crushing capacity= 425psi.
 - Unbalanced roof live loads have been considered for this design.
 - Wind: ASCE 7-16; Vult=130mph (3-second gust) Vasd=103mph; TC DL=6.0psf; BCDL=6.0psf; h=12ft; B=45ft; L=55ft; eave=7ft; Cat. II; Exp B; Enclosed; MWFRS (directional); cantilever left and right exposed ; end vertical left and right exposed; Lumber DOL=1.60 plate grip DOL=1.60
 - TCLL: ASCE 7-16; Pr=20.0 psf (roof LL: Lum DOL=1.15 Plate DOL=1.15); Pg=15.0 psf; Pf=16.5 psf (Lum DOL=1.15 Plate DOL=1.15); Is=1.0; Rough Cat B; Partially Exp.; Ce=1.0; Cs=1.00; Ct=1.10, Lu=50-0-0; Min. flat roof snow load governs. Rain surcharge applied to all exposed surfaces with slopes less than 0.500/12 in accordance with IBC 1608.3.4.
 - Unbalanced snow loads have been considered for this design.
 - This truss has been designed for greater of min roof live load of 12.0 psf or 1.00 times flat roof load of 11.6 psf on overhangs non-concurrent with other live loads.
 - Provide adequate drainage to prevent water ponding.
 - This truss has been designed for a 10.0 psf bottom chord live load nonconcurrent with any other live loads.
 - * This truss has been designed for a live load of 20.0psf on the bottom chord in all areas where a rectangle 3-6-0 tall by 2-0-0 wide will fit between the bottom chord and any other members, with BCDL = 10.0psf.
 - Provide mechanical connection (by others) of truss to bearing plate capable of withstanding 100 lb uplift at joint(s) 2, 18, 32.
 - This truss is designed in accordance with the 2018 International Residential Code sections R502.11.1 and R802.10.2 and referenced standard ANSI/TPI 1.
 - Graphical purlin representation does not depict the size or the orientation of the purlin along the top and/or bottom chord.



May 19, 2020

WARNING - Verify design parameters and READ NOTES ON THIS AND INCLUDED MITEK REFERENCE PAGE MII-7473 rev. 10/03/2015 BEFORE USE.
 Design valid for use only with MiTek® connectors. This design is based only upon parameters shown, and is for an individual building component, not a truss system. Before use, the building designer must verify the applicability of design parameters and properly incorporate this design into the overall building design. Bracing indicated is to prevent buckling of individual truss web and/or chord members only. Additional temporary and permanent bracing is always required for stability and to prevent collapse with possible personal injury and property damage. For general guidance regarding the fabrication, storage, delivery, erection and bracing of trusses and truss systems, see **ANSI/TPI1 Quality Criteria, DSB-89 and BCSI Building Component Safety Information** available from Truss Plate Institute, 218 N. Lee Street, Suite 312, Alexandria, VA 22314.



818 Soundside Road
 Edenton, NC 27932

Job	Truss	Truss Type	Qty	Ply	RICHARDSON	E14419882
P20-04027	T04	PIGGYBACK BASE	4	1	Job Reference (optional)	

Longleaf Truss Company, West End, NC - 27376,

8.330 s Mar 23 2020 MiTek Industries, Inc. Tue May 19 07:21:01 2020 Page 1

ID:gkUVx24QO5gIBKvEJRcThWzFI?4-2nl70WDcKBVyeHXal6i1oBpym0ugAKCuj7Mj3fzF?Pg

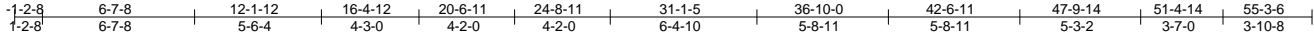

Scale = 1:100.3

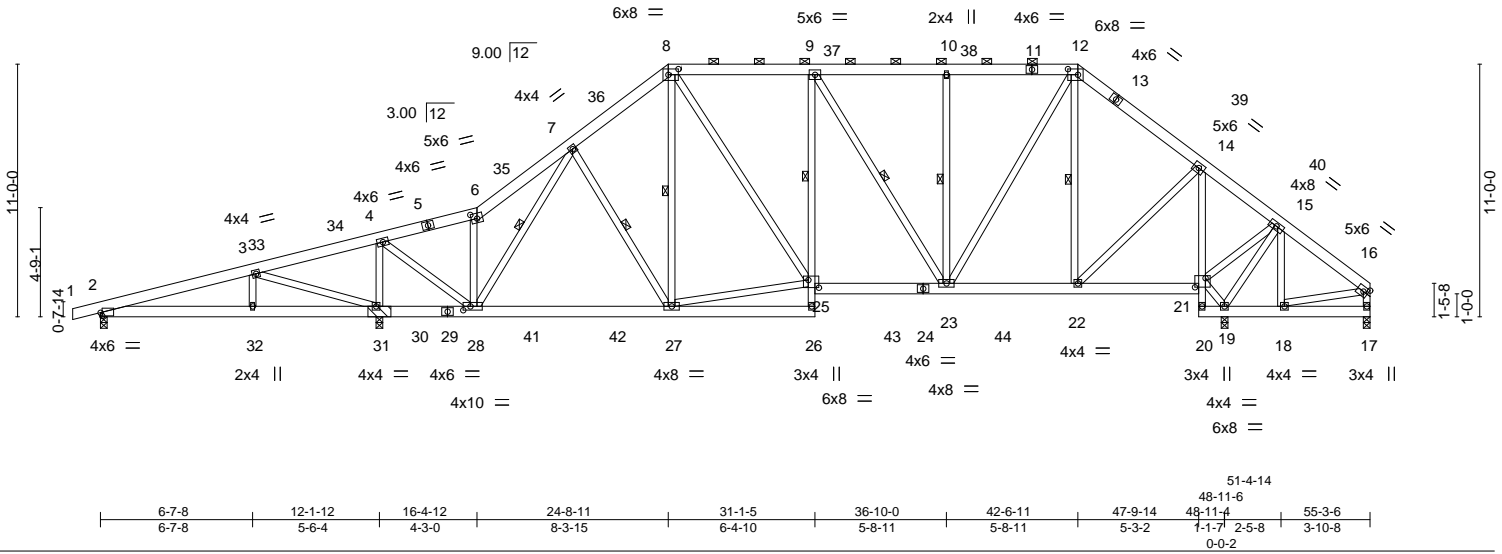

Job	Truss	Truss Type	Qty	Ply	RICHARDSON	E14419883
P20-04027	T05	Piggyback Base	1	1	Job Reference (optional)	

Longleaf Truss Company, West End, NC - 27376,

8.330 s Mar 23 2020 MiTek Industries, Inc. Tue May 19 07:21:04 2020 Page 1

ID:gkUVx24QO5glBKvEjRcThWzF1?4-TL_FeYGVc6tWVKG9QEFkQpRJ3Dw2Nj3KP5bOg_zF?pd

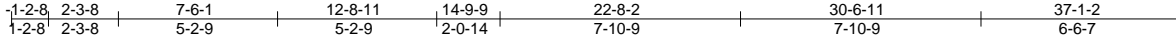

Scale = 1:75.5

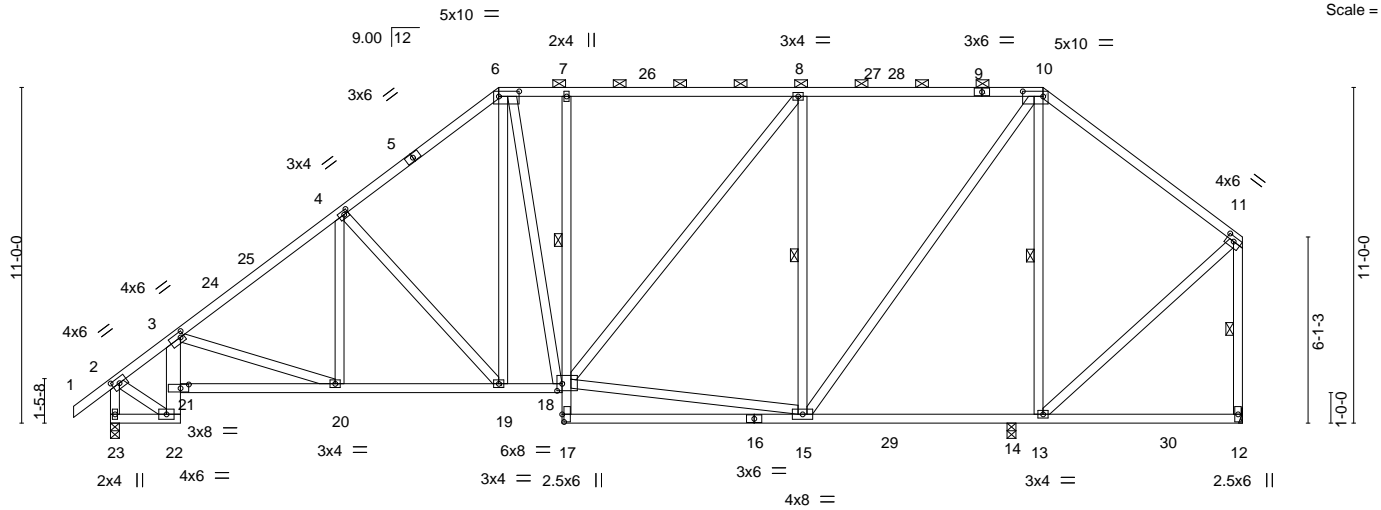

Plate Offsets (X,Y)--	2-3-8 2-3-8	7-6-1 5-2-9	12-8-11 5-2-9	14-9-9 2-0-14	22-8-2 7-10-9	29-8-1 6-11-15	30-6-11 0-10-10	37-1-2 6-6-7
-----------------------	----------------	----------------	------------------	------------------	------------------	-------------------	--------------------	-----------------

LOADING (psf)	SPACING-	CSI.	DEFL.	PLATES	GRIP
TCLL (roof) 20.0	2-0-0	TC 0.86	in (loc) l/defl L/d	MT20	244/190
Snow (Pf/Pg) 16.5/15.0	Plate Grip DOL 1.15	BC 0.69	Vert(LL) -0.13 15-17 >999 240		
TCDL 10.0	Lumber DOL 1.15	WB 0.73	Vert(CT) -0.27 15-17 >999 180		
BCLL 0.0 *	Rep Stress Incr YES	Matrix-S	Horz(CT) 0.11 12 n/a n/a		
BCDL 10.0	Code IRC2018/TPI2014			Weight: 301 lb	FT = 20%

LUMBER-	BRACING-
TOP CHORD 2x4 SP No.1	TOP CHORD Sheathed or 4-3-9 oc purlins, except end verticals, and 2-0-0 oc purlins (3-11-2 max.): 6-10.
BOT CHORD 2x4 SP No.1 *Except*	BOT CHORD Rigid ceiling directly applied or 10-0-0 oc bracing, Except:
3-22: 2x6 SP No.1, 7-17: 2x4 SP No.3	6-0-0 oc bracing: 21-22.
WEBS 2x4 SP No.3	1 Row at midpt 7-18
	1 Row at midpt 8-15, 10-13, 11-12

REACTIONS. (size) 23=0-3-8, 12=Mechanical, 14=0-3-8
 Max Horz 23=289(LC 11)
 Max Uplift 23=-36(LC 12), 12=-21(LC 12)
 Max Grav 23=1622(LC 24), 12=1255(LC 25), 14=563(LC 42)

FORCES. (lb) - Max. Comp./Max. Ten. - All forces 250 (lb) or less except when shown.
 TOP CHORD 2-3=-1384/36, 3-4=-2086/58, 4-6=-1694/117, 6-7=-1415/126, 7-8=-1416/127,
 8-10=-1261/134, 10-11=-859/119, 2-23=-1653/48, 11-12=-1108/58
 BOT CHORD 22-23=-263/232, 21-22=-539/0, 3-21=-471/22, 20-21=-181/1940, 19-20=-47/1723,
 18-19=-12/1377, 7-18=-484/63, 14-15=-7/628, 13-14=-7/628
 WEBS 4-20=0/288, 4-19=-620/81, 6-19=-5/620, 6-18=-32/549, 15-18=-19/1119, 8-18=-22/390,
 8-15=-850/90, 10-15=0/1136, 10-13=-770/39, 2-22=0/1161, 11-13=0/822

- NOTES-**
- 1) Unbalanced roof live loads have been considered for this design.
 - 2) Wind: ASCE 7-16; Vult=130mph (3-second gust) Vasd=103mph; TC DL=6.0psf; BCDL=6.0psf; h=12ft; B=45ft; L=37ft; eave=5ft; Cat. II; Exp B; Enclosed; MWFRS (directional); cantilever left and right exposed; end vertical left and right exposed; Lumber DOL=1.60 plate grip DOL=1.60
 - 3) TCLL: ASCE 7-16; Pr=20.0 psf (roof LL: Lum DOL=1.15 Plate DOL=1.15); Pg=15.0 psf; Pf=16.5 psf (Lum DOL=1.15 Plate DOL=1.15); Is=1.0; Rough Cat B; Partially Exp.; Ce=1.0; Cs=1.00; Ct=1.10, Lu=50-0-0; Min. flat roof snow load governs. Rain surcharge applied to all exposed surfaces with slopes less than 0.500/12 in accordance with IBC 1608.3.4.
 - 4) Unbalanced snow loads have been considered for this design.
 - 5) This truss has been designed for greater of min roof live load of 12.0 psf or 1.00 times flat roof load of 11.6 psf on overhangs non-concurrent with other live loads.
 - 6) Provide adequate drainage to prevent water ponding.
 - 7) This truss has been designed for a 10.0 psf bottom chord live load nonconcurrent with any other live loads.
 - 8) * This truss has been designed for a live load of 20.0psf on the bottom chord in all areas where a rectangle 3-6-0 tall by 2-0-0 wide will fit between the bottom chord and any other members, with BCDL = 10.0psf.
 - 9) Refer to girder(s) for truss to truss connections.
 - 10) Provide mechanical connection (by others) of truss to bearing plate capable of withstanding 100 lb uplift at joint(s) 23, 12.
 - 11) This truss is designed in accordance with the 2018 International Residential Code sections R502.11.1 and R802.10.2 and referenced standard ANSI/TPI 1.
 - 12) Graphical purlin representation does not depict the size or the orientation of the purlin along the top and/or bottom chord.



May 19, 2020

WARNING - Verify design parameters and READ NOTES ON THIS AND INCLUDED MITEK REFERENCE PAGE MII-7473 rev. 10/03/2015 BEFORE USE.
 Design valid for use only with MiTek® connectors. This design is based only upon parameters shown, and is for an individual building component, not a truss system. Before use, the building designer must verify the applicability of design parameters and properly incorporate this design into the overall building design. Bracing indicated is to prevent buckling of individual truss web and/or chord members only. Additional temporary and permanent bracing is always required for stability and to prevent collapse with possible personal injury and property damage. For general guidance regarding the fabrication, storage, delivery, erection and bracing of trusses and truss systems, see **ANSI/TPI Quality Criteria, DSB-89 and BCSI Building Component Safety Information** available from Truss Plate Institute, 218 N. Lee Street, Suite 312, Alexandria, VA 22314.



818 Soundside Road
 Edenton, NC 27932

Job	Truss	Truss Type	Qty	Ply	RICHARDSON	E14419884
P20-04027	T06	Piggyback Base	5	1	Job Reference (optional)	

Longleaf Truss Company,

West End, NC - 27376,

8.330 s Mar 23 2020 MiTek Industries, Inc. Tue May 19 07:21:07 2020 Page 1

ID: gkUVx24QO5gIBKvEjRcThWzFI?4-twfOHaInV1F5MC?k6NoR1S3tTR1ha3Ln53p2HJzF?pA



Scale = 1:70.2

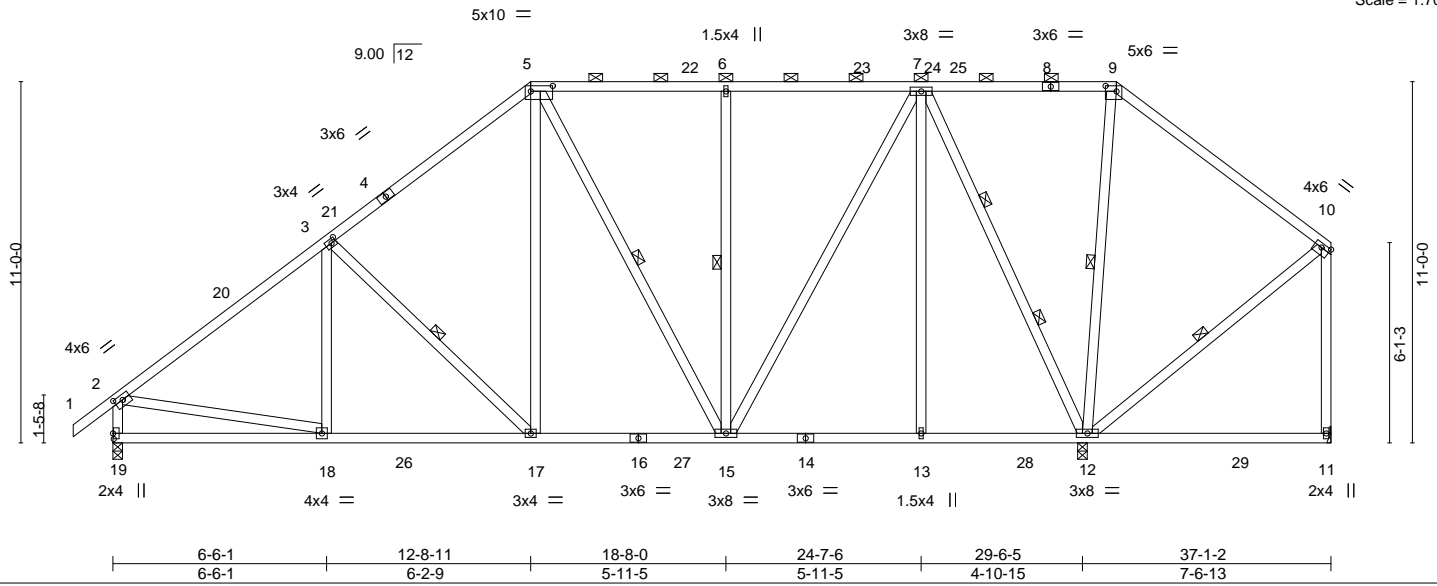

Plate Offsets (X,Y)-- [2:0-3-0,0-1-12], [3:0-1-12,0-1-8], [5:0-8-0,0-2-0], [9:0-4-0,0-2-0], [10:Edge,0-1-8], [19:0-2-0,0-0-4]

LOADING (psf)	SPACING-	CSI.	DEFL.	PLATES	GRIP
TCLL (roof) 20.0	2-0-0	TC 0.66	in (loc) l/defl L/d	MT20	244/190
Snow (Pf/Pg) 16.5/15.0	Plate Grip DOL 1.15	BC 0.37	Vert(LL) -0.09 11-12 >976 240		
TCDL 10.0	Lumber DOL 1.15	WB 0.82	Vert(CT) -0.16 11-12 >558 180		
BCLL 0.0 *	Rep Stress Incr YES	Matrix-S	Horz(CT) 0.02 11 n/a n/a		
BCDL 10.0	Code IRC2018/TPI2014			Weight: 288 lb	FT = 20%

LUMBER-
 TOP CHORD 2x4 SP No.1
 BOT CHORD 2x4 SP No.1
 WEBS 2x4 SP No.3

BRACING-
 TOP CHORD Sheathed or 4-11-4 oc purlins, except end verticals, and 2-0-0 oc purlins (6-0-0 max.): 5-9.
 Rigid ceiling directly applied or 10-0-0 oc bracing.
 BOT CHORD 1 Row at midpt 3-17, 5-15, 6-15, 9-12, 10-12
 WEBS 2 Rows at 1/3 pts 7-12

REACTIONS. (size) 19=0-3-8, 11=Mechanical, 12=0-3-8
 Max Horz 19=289(LC 11)
 Max Uplift 19=29(LC 12), 11=120(LC 50), 12=9(LC 12)
 Max Grav 19=1387(LC 24), 11=153(LC 39), 12=2213(LC 42)

FORCES. (lb) - Max. Comp./Max. Ten. - All forces 250 (lb) or less except when shown.
 TOP CHORD 2-3=-1504/44, 3-5=-1192/112, 5-6=-850/121, 6-7=-850/121, 9-10=-39/360,
 2-19=-1287/62
 BOT CHORD 18-19=-238/318, 17-18=-71/1256, 15-17=-36/954, 13-15=-43/492, 12-13=-43/492
 WEBS 3-17=-505/91, 5-17=0/599, 5-15=-339/38, 6-15=-519/72, 7-15=-2/859, 7-13=0/285,
 7-12=-1567/13, 9-12=-477/30, 2-18=0/980, 10-12=-291/77

NOTES-

- Unbalanced roof live loads have been considered for this design.
- Wind: ASCE 7-16; Vult=130mph (3-second gust) Vasd=103mph; TCDL=6.0psf; BCDL=6.0psf; h=12ft; B=45ft; L=37ft; eave=5ft; Cat. II; Exp B; Enclosed; MWFRS (directional); cantilever left and right exposed ; end vertical left and right exposed; Lumber DOL=1.60 plate grip DOL=1.60
- TCLL: ASCE 7-16; Pr=20.0 psf (roof LL: Lum DOL=1.15 Plate DOL=1.15); Pg=15.0 psf; Pf=16.5 psf (Lum DOL=1.15 Plate DOL=1.15); Is=1.0; Rough Cat B; Partially Exp.; Ce=1.0; Cs=1.00; Ct=1.10, Lu=50-0-0; Min. flat roof snow load governs. Rain surcharge applied to all exposed surfaces with slopes less than 0.500/12 in accordance with IBC 1608.3.4.
- Unbalanced snow loads have been considered for this design.
- This truss has been designed for greater of min roof live load of 12.0 psf or 1.00 times flat roof load of 11.6 psf on overhangs non-concurrent with other live loads.
- Provide adequate drainage to prevent water ponding.
- This truss has been designed for a 10.0 psf bottom chord live load nonconcurrent with any other live loads.
- * This truss has been designed for a live load of 20.0psf on the bottom chord in all areas where a rectangle 3-6-0 tall by 2-0-0 wide will fit between the bottom chord and any other members, with BCDL = 10.0psf.
- Refer to girder(s) for truss to truss connections.
- Provide mechanical connection (by others) of truss to bearing plate capable of withstanding 100 lb uplift at joint(s) 19, 12 except (jt=lb) 11=120.
- This truss is designed in accordance with the 2018 International Residential Code sections R502.11.1 and R802.10.2 and referenced standard ANSI/TPI 1.
- Graphical purlin representation does not depict the size or the orientation of the purlin along the top and/or bottom chord.

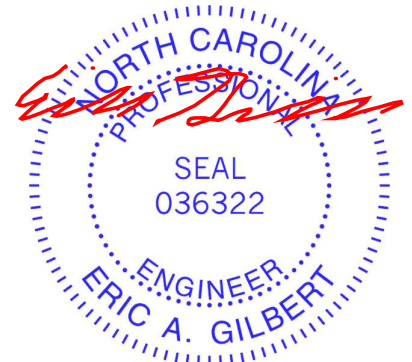

May 19, 2020

WARNING - Verify design parameters and READ NOTES ON THIS AND INCLUDED MITEK REFERENCE PAGE MII-7473 rev. 10/03/2015 BEFORE USE.

Design valid for use only with MiTek® connectors. This design is based only upon parameters shown, and is for an individual building component, not a truss system. Before use, the building designer must verify the applicability of design parameters and properly incorporate this design into the overall building design. Bracing indicated is to prevent buckling of individual truss web and/or chord members only. Additional temporary and permanent bracing is always required for stability and to prevent collapse with possible personal injury and property damage. For general guidance regarding the fabrication, storage, delivery, erection and bracing of trusses and truss systems, see **ANSI/TPI1 Quality Criteria, DSB-89 and BCSI Building Component Safety Information** available from Truss Plate Institute, 218 N. Lee Street, Suite 312, Alexandria, VA 22314.



818 Soundside Road
 Edenton, NC 27932

Job P20-04027	Truss T07	Truss Type Piggyback Base	Qty 5	Ply 1	RICHARDSON	E14419885
------------------	--------------	------------------------------	----------	----------	------------	-----------

Longleaf Truss Company, West End, NC - 27376,

8.330 s Mar 23 2020 MiTek Industries, Inc. Tue May 19 07:21:09 2020 Page 1

ID: gkUVx24QO5glBKvEjRcThWzF1?4-pJn8hFKdReVpbV86Dorv7t88iEev2wS3ZMI9LbzF?p8

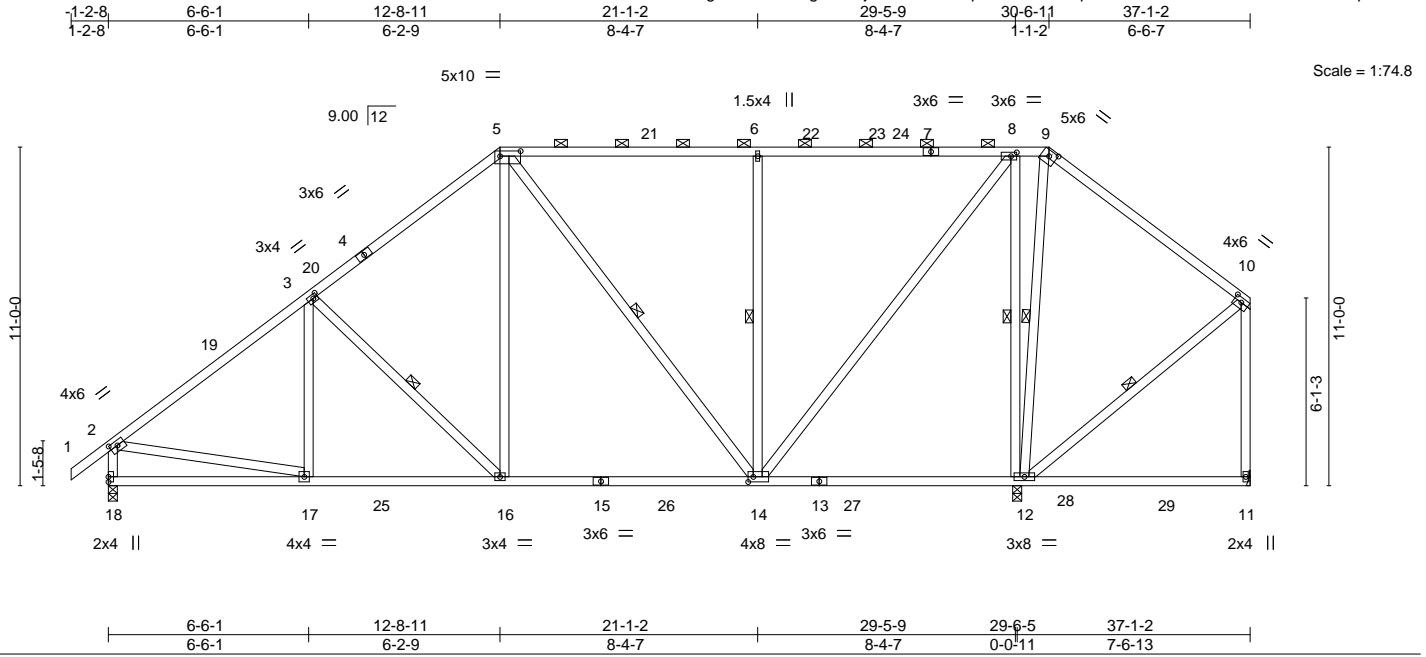

Plate Offsets (X,Y)-- [2:0-3-0,0-1-12], [3:0-1-12,0-1-8], [5:0-8-0,0-2-0], [8:0-2-4,0-1-8], [9:0-3-0,0-2-2], [10:0-3-0,0-1-12], [14:0-2-0,0-2-0]

LOADING (psf)	SPACING-	CSI.	DEFL.	PLATES	GRIP
TCLL (roof) 20.0	2-0-0	TC 1.00	in (loc) l/defl L/d	MT20	244/190
Snow (Pf/Pg) 16.5/15.0	Plate Grip DOL 1.15	BC 0.58	Vert(LL) -0.14 12-14 >999 240		
TCDL 10.0	Lumber DOL 1.15	WB 0.97	Vert(CT) -0.23 14-16 >999 180		
BCLL 0.0 *	Rep Stress Incr YES	Matrix-S	Horz(CT) 0.02 11 n/a n/a		
BCDL 10.0	Code IRC2018/TPI2014			Weight: 275 lb	FT = 20%

LUMBER-
 TOP CHORD 2x4 SP No.1
 BOT CHORD 2x4 SP No.1
 WEBS 2x4 SP No.3

BRACING-
 TOP CHORD Sheathed or 4-10-13 oc purlins, except end verticals, and 2-0-0 oc purlins (2-2-0 max.): 5-9.
 BOT CHORD Rigid ceiling directly applied or 10-0-0 oc bracing, Except: 6-0-0 oc bracing: 12-14.
 WEBS 1 Row at midpt 3-16, 5-14, 6-14, 8-12, 9-12, 10-12

REACTIONS. (size) 18=0-3-8, 11=Mechanical, 12=0-3-8
 Max Horz 18=289(LC 11)
 Max Uplift 18=-29(LC 12), 11=-86(LC 50), 12=-6(LC 12)
 Max Grav 18=1406(LC 24), 11=184(LC 39), 12=2154(LC 42)

FORCES. (lb) - Max. Comp./Max. Ten. - All forces 250 (lb) or less except when shown.
 TOP CHORD 2-3=-1523/45, 3-5=-1229/111, 5-6=-798/122, 6-8=-798/122, 9-10=-70/304,
 2-18=-1301/64
 BOT CHORD 17-18=-237/325, 16-17=-70/1271, 14-16=-31/987
 WEBS 3-16=-485/93, 5-16=0/652, 5-14=-440/17, 6-14=-776/108, 8-14=-5/1479, 8-12=-1669/56,
 9-12=-425/23, 2-17=0/989

NOTES-

- Unbalanced roof live loads have been considered for this design.
- Wind: ASCE 7-16; Vult=130mph (3-second gust) Vasd=103mph; TCCL=6.0psf; BCDL=6.0psf; h=12ft; B=45ft; L=37ft; eave=5ft; Cat. II; Exp B; Enclosed; MWFRS (directional); cantilever left and right exposed; end vertical left and right exposed; Lumber DOL=1.60 plate grip DOL=1.60
- TCCL: ASCE 7-16; Pr=20.0 psf (roof LL: Lum DOL=1.15 Plate DOL=1.15); Pg=15.0 psf; Pf=16.5 psf (Lum DOL=1.15 Plate DOL=1.15); Is=1.0; Rough Cat B; Partially Exp.; Ce=1.0; Cs=1.00; Ct=1.10, Lu=50-0-0; Min. flat roof snow load governs. Rain surcharge applied to all exposed surfaces with slopes less than 0.500/12 in accordance with IBC 1608.3.4.
- Unbalanced snow loads have been considered for this design.
- This truss has been designed for greater of min roof live load of 12.0 psf or 1.00 times flat roof load of 11.6 psf on overhangs non-concurrent with other live loads.
- Provide adequate drainage to prevent water ponding.
- This truss has been designed for a 10.0 psf bottom chord live load nonconcurrent with any other live loads.
- * This truss has been designed for a live load of 20.0psf on the bottom chord in all areas where a rectangle 3-6-0 tall by 2-0-0 wide will fit between the bottom chord and any other members, with BCDL = 10.0psf.
- Refer to girder(s) for truss to truss connections.
- Provide mechanical connection (by others) of truss to bearing plate capable of withstanding 100 lb uplift at joint(s) 18, 11, 12.
- This truss is designed in accordance with the 2018 International Residential Code sections R502.11.1 and R802.10.2 and referenced standard ANSI/TPI 1.
- Graphical purlin representation does not depict the size or the orientation of the purlin along the top and/or bottom chord.

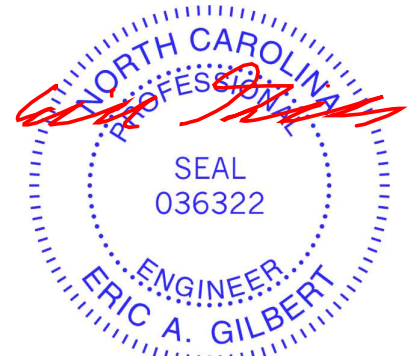

May 19, 2020

WARNING - Verify design parameters and READ NOTES ON THIS AND INCLUDED MITEK REFERENCE PAGE MII-7473 rev. 10/03/2015 BEFORE USE.

Design valid for use only with MiTek® connectors. This design is based only upon parameters shown, and is for an individual building component, not a truss system. Before use, the building designer must verify the applicability of design parameters and properly incorporate this design into the overall building design. Bracing indicated is to prevent buckling of individual truss web and/or chord members only. Additional temporary and permanent bracing is always required for stability and to prevent collapse with possible personal injury and property damage. For general guidance regarding the fabrication, storage, delivery, erection and bracing of trusses and truss systems, see **ANSI/TPI Quality Criteria, DSB-89 and BCSI Building Component Safety Information** available from Truss Plate Institute, 218 N. Lee Street, Suite 312, Alexandria, VA 22314.



818 Soundside Road
 Edenton, NC 27932

Job	Truss	Truss Type	Qty	Ply	RICHARDSON	E14419886
P20-04027	T08	Piggyback Base Supported Gable	1	1	Job Reference (optional)	

Longleaf Truss Company,

West End, NC - 27376,

8.330 s Mar 23 2020 MiTek Industries, Inc. Tue May 19 07:21:11 2020 Page 1

ID:gkUVx24QO5glBKvEJRcThWzFI?4-livv6xLuzGmXrpIVLDtNCIEg02SyW06M0gnFQ4zF?p6

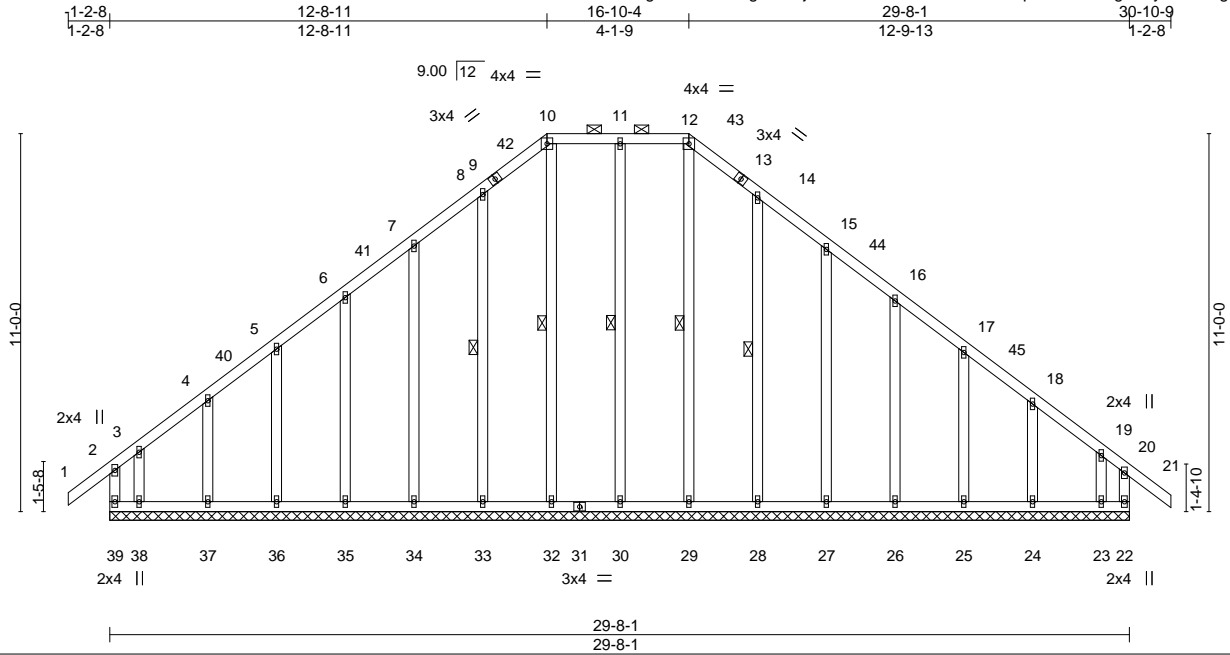

Scale = 1:67.0

LOADING (psf)	SPACING-	CSI.	DEFL.	in (loc)	l/defl	L/d	PLATES	GRIP
TCLL (roof) 20.0	2-0-0	TC 0.24	Vert(LL) -0.01	21	n/r	120	MT20	244/190
Snow (Pf/Pg) 16.5/15.0	Plate Grip DOL 1.15	BC 0.10	Vert(CT) -0.01	21	n/r	120		
TCDL 10.0	Lumber DOL 1.15	WB 0.19	Horz(CT) -0.01	22	n/a	n/a		
BCLL 0.0 *	Rep Stress Incr YES	Matrix-R						
BCDL 10.0	Code IRC2018/TPI2014						Weight: 246 lb	FT = 20%

LUMBER-	BRACING-
TOP CHORD 2x4 SP No.1	TOP CHORD Sheathed or 6-0-0 oc purlins, except end verticals, and 2-0-0 oc purlins (6-0-0 max.): 10-12.
BOT CHORD 2x4 SP No.1	BOT CHORD Rigid ceiling directly applied or 6-0-0 oc bracing.
WEBS 2x4 SP No.3	WEBS 1 Row at midpt 12-29, 11-30, 10-32, 8-33, 14-28
OTHERS 2x4 SP No.3	

REACTIONS. All bearings 29-8-1.
 (lb) - Max Horz 39=-249(LC 10)
 Max Uplift All uplift 100 lb or less at joint(s) 33, 34, 35, 36, 37, 28, 27, 26, 25, 24 except 39=-237(LC 10), 22=-203(LC 11), 38=-193(LC 11), 23=-164(LC 10)
 Max Grav All reactions 250 lb or less at joint(s) 29, 30, 32, 33, 34, 35, 36, 37, 28, 27, 26, 25, 24 except 39=324(LC 25), 22=296(LC 24), 38=302(LC 10), 23=273(LC 11)

FORCES. (lb) - Max. Comp./Max. Ten. - All forces 250 (lb) or less except when shown.
 TOP CHORD 8-10=-67/268, 12-14=-58/269

- NOTES-**
- 1) Unbalanced roof live loads have been considered for this design.
 - 2) Wind: ASCE 7-16; Vult=130mph (3-second gust) Vasd=103mph; TCCL=6.0psf; BCDL=6.0psf; h=12ft; B=45ft; L=30ft; eave=2ft; Cat. II; Exp B; Enclosed; MWFRS (directional); cantilever left and right exposed ; end vertical left and right exposed; Lumber DOL=1.60 plate grip DOL=1.60
 - 3) Truss designed for wind loads in the plane of the truss only. For studs exposed to wind (normal to the face), see Standard Industry Gable End Details as applicable, or consult qualified building designer as per ANSI/TPI 1.
 - 4) TCLL: ASCE 7-16; Pr=20.0 psf (roof LL: Lum DOL=1.15 Plate DOL=1.15); Pg=15.0 psf; Pf=16.5 psf (Lum DOL=1.15 Plate DOL=1.15); Is=1.0; Rough Cat B; Partially Exp.; Ce=1.0; Cs=1.00; Ct=1.10, Lu=50-0-0; Min. flat roof snow load governs. Rain surcharge applied to all exposed surfaces with slopes less than 0.500/12 in accordance with IBC 1608.3.4.
 - 5) Unbalanced snow loads have been considered for this design.
 - 6) This truss has been designed for greater of min roof live load of 12.0 psf or 1.00 times flat roof load of 11.6 psf on overhangs non-concurrent with other live loads.
 - 7) Provide adequate drainage to prevent water ponding.
 - 8) All plates are 1.5x4 MT20 unless otherwise indicated.
 - 9) Gable requires continuous bottom chord bearing.
 - 10) Truss to be fully sheathed from one face or securely braced against lateral movement (i.e. diagonal web).
 - 11) Gable studs spaced at 2-0-0 oc.
 - 12) This truss has been designed for a 10.0 psf bottom chord live load nonconcurrent with any other live loads.
 - 13) * This truss has been designed for a live load of 20.0psf on the bottom chord in all areas where a rectangle 3-6-0 tall by 2-0-0 wide will fit between the bottom chord and any other members.
 - 14) Provide mechanical connection (by others) of truss to bearing plate capable of withstanding 100 lb uplift at joint(s) 33, 34, 35, 36, 37, 28, 27, 26, 25, 24 except (jt=lb) 39=237, 22=203, 38=193, 23=164.
 - 15) This truss is designed in accordance with the 2018 International Residential Code sections R502.11.1 and R802.10.2 and referenced standard ANSI/TPI 1.
 - 16) Graphical purlin representation does not depict the size or the orientation of the purlin along the top and/or bottom chord.



May 19, 2020

WARNING - Verify design parameters and READ NOTES ON THIS AND INCLUDED MITEK REFERENCE PAGE MII-7473 rev. 10/03/2015 BEFORE USE.
 Design valid for use only with MiTek® connectors. This design is based only upon parameters shown, and is for an individual building component, not a truss system. Before use, the building designer must verify the applicability of design parameters and properly incorporate this design into the overall building design. Bracing indicated is to prevent buckling of individual truss web and/or chord members only. Additional temporary and permanent bracing is always required for stability and to prevent collapse with possible personal injury and property damage. For general guidance regarding the fabrication, storage, delivery, erection and bracing of trusses and truss systems, see **ANSI/TPI Quality Criteria, DSB-89 and BCSI Building Component Safety Information** available from Truss Plate Institute, 218 N. Lee Street, Suite 312, Alexandria, VA 22314.



818 Soundside Road
 Edenton, NC 27932

Job	Truss	Truss Type	Qty	Ply	RICHARDSON	E14419887
P20-04027	T09	Common	1	1		

Longleaf Truss Company,

West End, NC - 27376,

8.330 s Mar 23 2020 MiTek Industries, Inc. Tue May 19 07:21:13 2020 Page 1

ID: gkUVx24QO5glBKvEjRcThWzF1?4-i40fXdN8Vt0F47StSdvrHjJ_2r35_vqfU_GMUyzF?p4

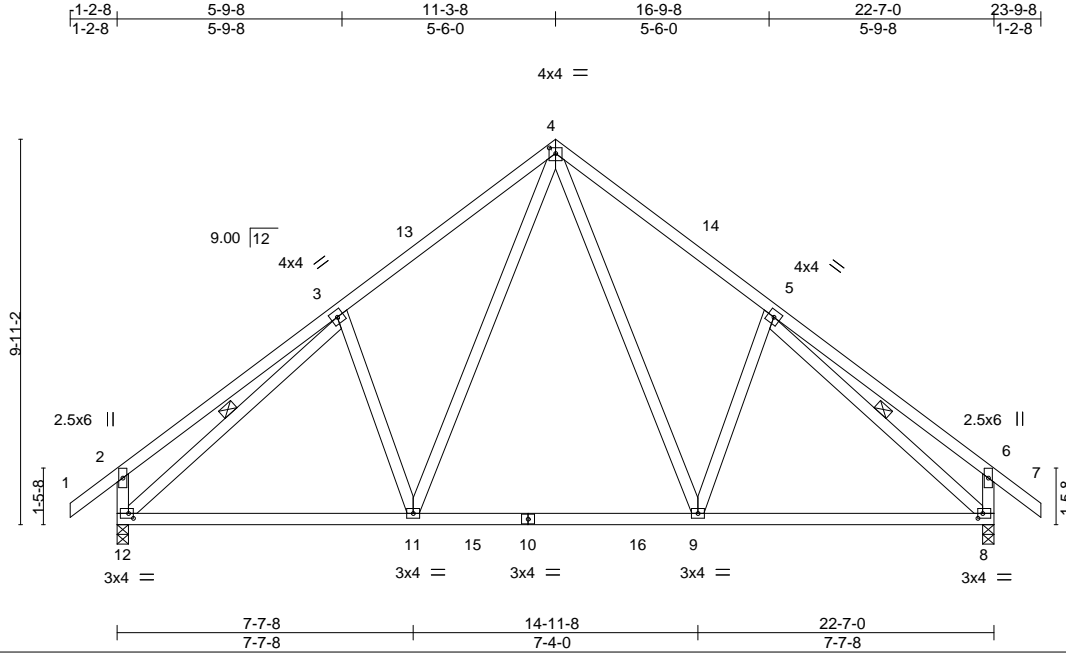

Plate Offsets (X,Y)-- [4:0-2-0,0-1-12], [8:0-1-8,0-1-8], [12:0-1-8,0-1-8]

LOADING (psf)	SPACING-	CSI.	DEFL.	PLATES	GRIP
TCLL (roof) 20.0	2-0-0	TC 0.34	in (loc) l/defl L/d	MT20	244/190
Snow (Pf/Pg) 11.6/15.0	Plate Grip DOL 1.15	BC 0.44	Vert(LL) -0.09 9-11 >999 240		
TCDL 10.0	Lumber DOL 1.15	WB 0.31	Vert(CT) -0.14 11-12 >999 180		
BCLL 0.0 *	Rep Stress Incr YES	Matrix-S	Horz(CT) 0.02 8 n/a n/a		
BCDL 10.0	Code IRC2018/TPI2014			Weight: 152 lb	FT = 20%

LUMBER-
 TOP CHORD 2x4 SP No.1
 BOT CHORD 2x4 SP No.1
 WEBS 2x4 SP No.3

BRACING-
 TOP CHORD Sheathed or 5-11-13 oc purlins, except end verticals.
 BOT CHORD Rigid ceiling directly applied or 10-0-0 oc bracing.
 WEBS 1 Row at midpt 3-12, 5-8

REACTIONS. (size) 12=0-3-8, 8=0-3-8
 Max Horz 12=220(LC 11)
 Max Uplift 12=-33(LC 12), 8=-33(LC 12)
 Max Grav 12=1077(LC 24), 8=1077(LC 25)

FORCES. (lb) - Max. Comp./Max. Ten. - All forces 250 (lb) or less except when shown.
 TOP CHORD 2-3=-305/122, 3-4=-1045/132, 4-5=-1045/132, 5-6=-304/122, 2-12=-368/125, 6-8=-368/125
 BOT CHORD 11-12=0/913, 9-11=0/656, 8-9=0/816
 WEBS 4-9=-41/533, 4-11=-41/533, 3-12=-950/0, 5-8=-950/0

- NOTES-**
- Unbalanced roof live loads have been considered for this design.
 - Wind: ASCE 7-16; Vult=130mph (3-second gust) Vasd=103mph; TCDL=6.0psf; BCDL=6.0psf; h=12ft; B=45ft; L=24ft; eave=4ft; Cat. II; Exp B; Enclosed; MWFRS (directional); cantilever left and right exposed; end vertical left and right exposed; Lumber DOL=1.60 plate grip DOL=1.60
 - TCLL: ASCE 7-16; Pr=20.0 psf (roof LL: Lum DOL=1.15 Plate DOL=1.15); Pg=15.0 psf; Pf=11.6 psf (Lum DOL=1.15 Plate DOL=1.15); Is=1.0; Rough Cat B; Partially Exp.; Ce=1.0; Cs=1.00; Ct=1.10
 - Unbalanced snow loads have been considered for this design.
 - This truss has been designed for greater of min roof live load of 12.0 psf or 1.00 times flat roof load of 11.6 psf on overhangs non-concurrent with other live loads.
 - This truss has been designed for a 10.0 psf bottom chord live load nonconcurrent with any other live loads.
 - * This truss has been designed for a live load of 20.0psf on the bottom chord in all areas where a rectangle 3-6-0 tall by 2-0-0 wide will fit between the bottom chord and any other members, with BCDL = 10.0psf.
 - Provide mechanical connection (by others) of truss to bearing plate capable of withstanding 100 lb uplift at joint(s) 12, 8.
 - This truss is designed in accordance with the 2018 International Residential Code sections R502.11.1 and R802.10.2 and referenced standard ANSI/TPI 1.

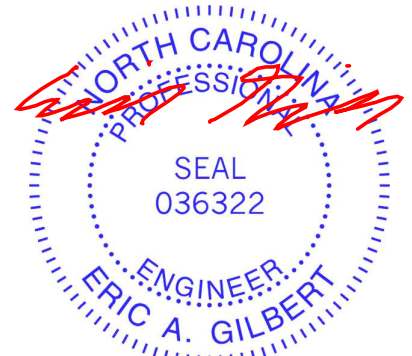

May 19, 2020

WARNING - Verify design parameters and READ NOTES ON THIS AND INCLUDED MITEK REFERENCE PAGE MII-7473 rev. 10/03/2015 BEFORE USE.

Design valid for use only with MiTek® connectors. This design is based only upon parameters shown, and is for an individual building component, not a truss system. Before use, the building designer must verify the applicability of design parameters and properly incorporate this design into the overall building design. Bracing indicated is to prevent buckling of individual truss web and/or chord members only. Additional temporary and permanent bracing is always required for stability and to prevent collapse with possible personal injury and property damage. For general guidance regarding the fabrication, storage, delivery, erection and bracing of trusses and truss systems, see **ANSI/TPI1 Quality Criteria, DSB-89 and BCSI Building Component Safety Information** available from Truss Plate Institute, 218 N. Lee Street, Suite 312, Alexandria, VA 22314.



818 Soundside Road
 Edenton, NC 27932

Job	Truss	Truss Type	Qty	Ply	RICHARDSON	E14419888
P20-04027	T10	Common	2	1	Job Reference (optional)	

Longleaf Truss Company,

West End, NC - 27376,

8.330 s Mar 23 2020 MiTek Industries, Inc. Tue May 19 07:21:14 2020 Page 1

ID: gkUVx24QO5glBKvEjRcThWzFI?4-AHa1zNmGB86iG140LQ4pwr8nFPKjM40ie0w0PzF?p3

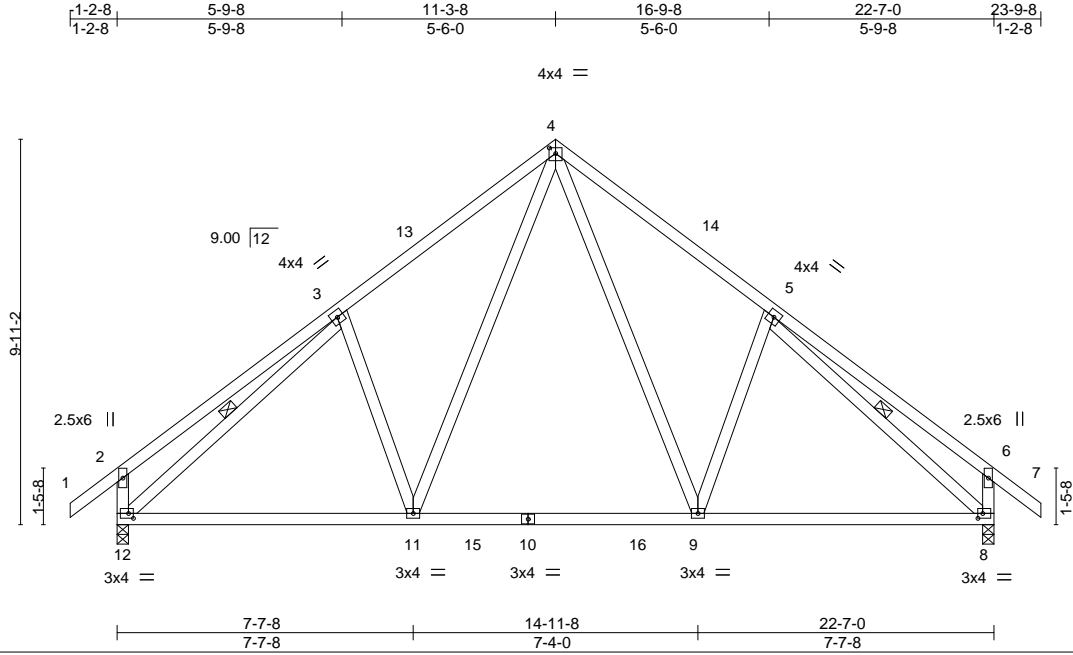

Scale = 1:59.3

Plate Offsets (X,Y)-- [4:0-2-0,0-1-12], [8:0-1-8,0-1-8], [12:0-1-8,0-1-8]

LOADING (psf)	SPACING-	CSI.	DEFL.	PLATES	GRIP
TCLL (roof) 20.0	2-0-0	TC 0.34	in (loc) l/defl L/d	MT20	244/190
Snow (Pf/Pg) 11.6/15.0	Plate Grip DOL 1.15	BC 0.44	Vert(LL) -0.09 9-11 >999 240		
TCDL 10.0	Lumber DOL 1.15	WB 0.31	Vert(CT) -0.14 11-12 >999 180		
BCLL 0.0 *	Rep Stress Incr YES	Matrix-S	Horz(CT) 0.02 8 n/a n/a		
BCDL 10.0	Code IRC2018/TPI2014			Weight: 152 lb	FT = 20%

LUMBER-	BRACING-
TOP CHORD 2x4 SP No.1	TOP CHORD Sheathed or 5-11-13 oc purlins, except end verticals.
BOT CHORD 2x4 SP No.1	BOT CHORD Rigid ceiling directly applied or 10-0-0 oc bracing.
WEBS 2x4 SP No.3	WEBS 1 Row at midpt 3-12, 5-8

REACTIONS. (size) 12=0-3-8, 8=0-3-8
 Max Horz 12=220(LC 11)
 Max Uplift 12=-33(LC 12), 8=-33(LC 12)
 Max Grav 12=1077(LC 24), 8=1077(LC 25)

FORCES. (lb) - Max. Comp./Max. Ten. - All forces 250 (lb) or less except when shown.
 TOP CHORD 2-3=-305/122, 3-4=-1045/132, 4-5=-1045/132, 5-6=-304/122, 2-12=-368/125, 6-8=-368/125
 BOT CHORD 11-12=0/913, 9-11=0/656, 8-9=0/816
 WEBS 4-9=-41/533, 4-11=-41/533, 3-12=-950/0, 5-8=-950/0

- NOTES-**
- Unbalanced roof live loads have been considered for this design.
 - Wind: ASCE 7-16; Vult=130mph (3-second gust) Vasd=103mph; TCDL=6.0psf; BCDL=6.0psf; h=12ft; B=45ft; L=24ft; eave=4ft; Cat. II; Exp B; Enclosed; MWFRS (directional); cantilever left and right exposed; end vertical left and right exposed; Lumber DOL=1.60 plate grip DOL=1.60
 - TCLL: ASCE 7-16; Pr=20.0 psf (roof LL: Lum DOL=1.15 Plate DOL=1.15); Pg=15.0 psf; Pf=11.6 psf (Lum DOL=1.15 Plate DOL=1.15); Is=1.0; Rough Cat B; Partially Exp.; Ce=1.0; Cs=1.00; Ct=1.10
 - Unbalanced snow loads have been considered for this design.
 - This truss has been designed for greater of min roof live load of 12.0 psf or 1.00 times flat roof load of 11.6 psf on overhangs non-concurrent with other live loads.
 - This truss has been designed for a 10.0 psf bottom chord live load nonconcurrent with any other live loads.
 - * This truss has been designed for a live load of 20.0psf on the bottom chord in all areas where a rectangle 3-6-0 tall by 2-0-0 wide will fit between the bottom chord and any other members, with BCDL = 10.0psf.
 - Provide mechanical connection (by others) of truss to bearing plate capable of withstanding 100 lb uplift at joint(s) 12, 8.
 - This truss is designed in accordance with the 2018 International Residential Code sections R502.11.1 and R802.10.2 and referenced standard ANSI/TPI 1.

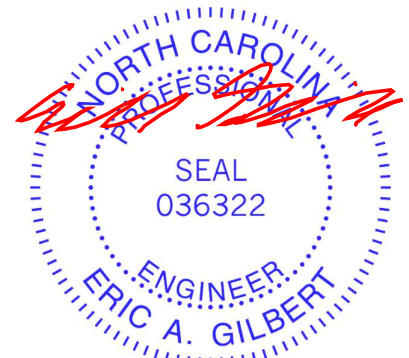

May 19, 2020

WARNING - Verify design parameters and READ NOTES ON THIS AND INCLUDED MITEK REFERENCE PAGE MII-7473 rev. 10/03/2015 BEFORE USE.
 Design valid for use only with MiTek® connectors. This design is based only upon parameters shown, and is for an individual building component, not a truss system. Before use, the building designer must verify the applicability of design parameters and properly incorporate this design into the overall building design. Bracing indicated is to prevent buckling of individual truss web and/or chord members only. Additional temporary and permanent bracing is always required for stability and to prevent collapse with possible personal injury and property damage. For general guidance regarding the fabrication, storage, delivery, erection and bracing of trusses and truss systems, see **ANSI/TPI1 Quality Criteria, DSB-89 and BCSI Building Component Safety Information** available from Truss Plate Institute, 218 N. Lee Street, Suite 312, Alexandria, VA 22314.

ENGINEERING BY
TRENCO
 A MiTek Affiliate
 818 Soundside Road
 Edenton, NC 27932

Job	Truss	Truss Type	Qty	Ply	RICHARDSON	E14419889
P20-04027	T11	Piggyback Base	1	1	Job Reference (optional)	

Longleaf Truss Company,

West End, NC - 27376,

8.330 s Mar 23 2020 MiTek Industries, Inc. Tue May 19 07:21:16 2020 Page 1

ID: gkUVx24QO5glBKvEjRcThWzF1?4-6finAeP0ooOpxaBS7mTYvLxR034qB8d5AyV05HzF?p1

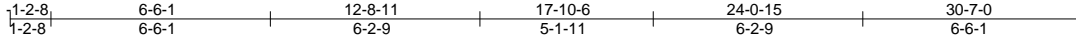

Scale = 1:68.3

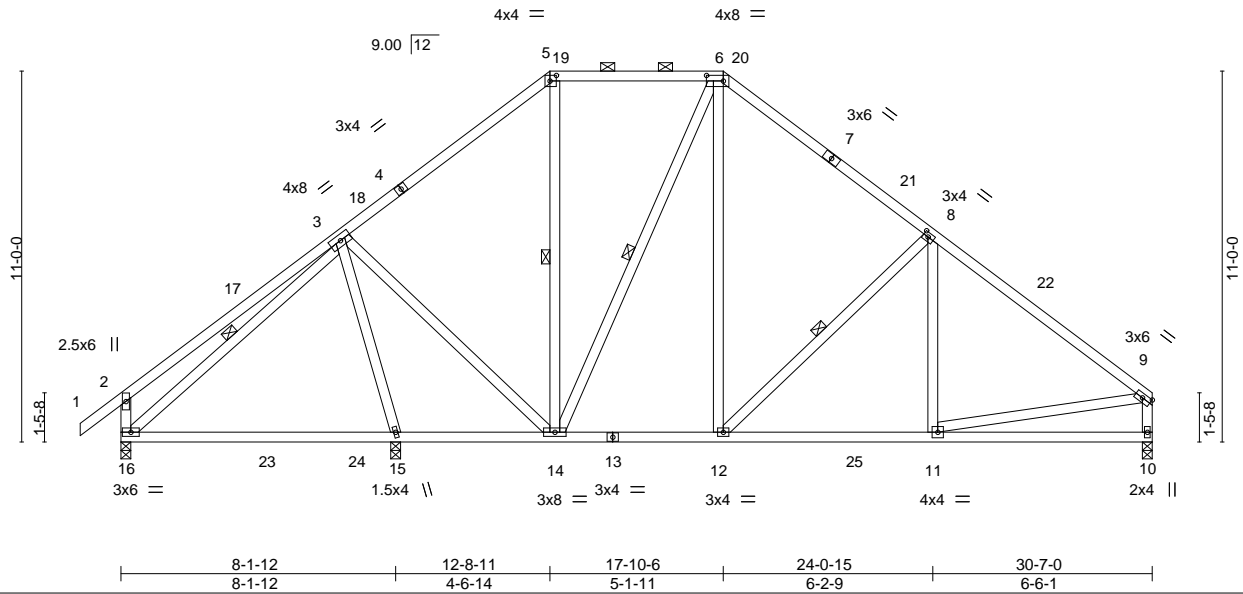

Plate Offsets (X,Y)-- [5:0-2-4,0-2-0], [6:0-6-0,0-2-0], [8:0-1-12,0-1-8], [9:Edge,0-1-8]

LOADING (psf)	SPACING-	CSI.	DEFL.	PLATES	GRIP
TCLL (roof) 20.0	2-0-0	TC 0.52	in (loc) l/defl L/d	MT20	244/190
Snow (Pf/Pg) 16.5/15.0	Plate Grip DOL 1.15	BC 0.44	Vert(LL) -0.14 15-16 >710 240		
TCDL 10.0	Lumber DOL 1.15	WB 0.82	Vert(CT) -0.23 15-16 >426 180		
BCLL 0.0 *	Rep Stress Incr YES	Matrix-S	Horz(CT) 0.02 10 n/a n/a		
BCDL 10.0	Code IRC2018/TPI2014			Weight: 218 lb	FT = 20%

LUMBER-

TOP CHORD 2x4 SP No.1
 BOT CHORD 2x4 SP No.1
 WEBS 2x4 SP No.3

BRACING-

TOP CHORD Sheathed or 5-4-7 oc purlins, except end verticals, and 2-0-0 oc purlins (6-0-0 max.): 5-6.
 BOT CHORD Rigid ceiling directly applied or 10-0-0 oc bracing, Except: 6-0-0 oc bracing: 14-15.
 WEBS 1 Row at midpt 5-14, 6-14, 8-12, 3-16

REACTIONS.

(size) 15=0-3-8, 16=0-3-8, 10=0-3-8
 Max Horz 16=242(LC 11)
 Max Uplift 16=48(LC 12), 10=5(LC 12)
 Max Grav 15=1364(LC 43), 16=539(LC 24), 10=1100(LC 45)

FORCES. (lb) - Max. Comp./Max. Ten. - All forces 250 (lb) or less except when shown.

TOP CHORD 2-3=-345/137, 3-5=-695/132, 5-6=-436/138, 6-8=-903/127, 8-9=-1250/54,
 2-16=-403/136, 9-10=-1000/38
 BOT CHORD 15-16=-66/345, 12-14=0/632, 11-12=0/918
 WEBS 3-15=-1102/72, 3-14=0/669, 6-14=-482/0, 6-12=0/619, 8-12=-537/91, 9-11=0/835

NOTES-

- Unbalanced roof live loads have been considered for this design.
- Wind: ASCE 7-16; Vult=130mph (3-second gust) Vasd=103mph; TCDL=6.0psf; BCDL=6.0psf; h=12ft; B=45ft; L=31ft; eave=4ft; Cat. II; Exp B; Enclosed; MWFRS (directional); cantilever left and right exposed; end vertical left and right exposed; Lumber DOL=1.60 plate grip DOL=1.60
- TCLL: ASCE 7-16; Pr=20.0 psf (roof LL: Lum DOL=1.15 Plate DOL=1.15); Pg=15.0 psf; Pf=16.5 psf (Lum DOL=1.15 Plate DOL=1.15); Is=1.0; Rough Cat B; Partially Exp.; Ce=1.0; Cs=1.00; Ct=1.10, Lu=50-0-0; Min. flat roof snow load governs. Rain surcharge applied to all exposed surfaces with slopes less than 0.500/12 in accordance with IBC 1608.3.4.
- Unbalanced snow loads have been considered for this design.
- This truss has been designed for greater of min roof live load of 12.0 psf or 1.00 times flat roof load of 11.6 psf on overhangs non-concurrent with other live loads.
- Provide adequate drainage to prevent water ponding.
- This truss has been designed for a 10.0 psf bottom chord live load nonconcurrent with any other live loads.
- * This truss has been designed for a live load of 20.0psf on the bottom chord in all areas where a rectangle 3-6-0 tall by 2-0-0 wide will fit between the bottom chord and any other members, with BCDL = 10.0psf.
- Provide mechanical connection (by others) of truss to bearing plate capable of withstanding 100 lb uplift at joint(s) 16, 10.
- This truss is designed in accordance with the 2018 International Residential Code sections R502.11.1 and R802.10.2 and referenced standard ANSI/TPI 1.
- Graphical purlin representation does not depict the size or the orientation of the purlin along the top and/or bottom chord.



May 19, 2020

WARNING - Verify design parameters and READ NOTES ON THIS AND INCLUDED MITEK REFERENCE PAGE MII-7473 rev. 10/03/2015 BEFORE USE.

Design valid for use only with MiTek® connectors. This design is based only upon parameters shown, and is for an individual building component, not a truss system. Before use, the building designer must verify the applicability of design parameters and properly incorporate this design into the overall building design. Bracing indicated is to prevent buckling of individual truss web and/or chord members only. Additional temporary and permanent bracing is always required for stability and to prevent collapse with possible personal injury and property damage. For general guidance regarding the fabrication, storage, delivery, erection and bracing of trusses and truss systems, see **ANSI/TPI1 Quality Criteria, DSB-89 and BCSI Building Component Safety Information** available from Truss Plate Institute, 218 N. Lee Street, Suite 312, Alexandria, VA 22314.



818 Soundside Road
 Edenton, NC 27932

Job	Truss	Truss Type	Qty	Ply	RICHARDSON	E14419890
P20-04027	T12	Piggyback Base	3	1	Job Reference (optional)	

Longleaf Truss Company,

West End, NC - 27376,

8.330 s Mar 23 2020 MiTek Industries, Inc. Tue May 19 07:21:18 2020 Page 1

ID: gkUVx24QO5gIBKvEjRcThWzFI?4-22qYaKQHJPeXAuLrFBV0_m0nwsnZf8nOdG_79AzF?p?

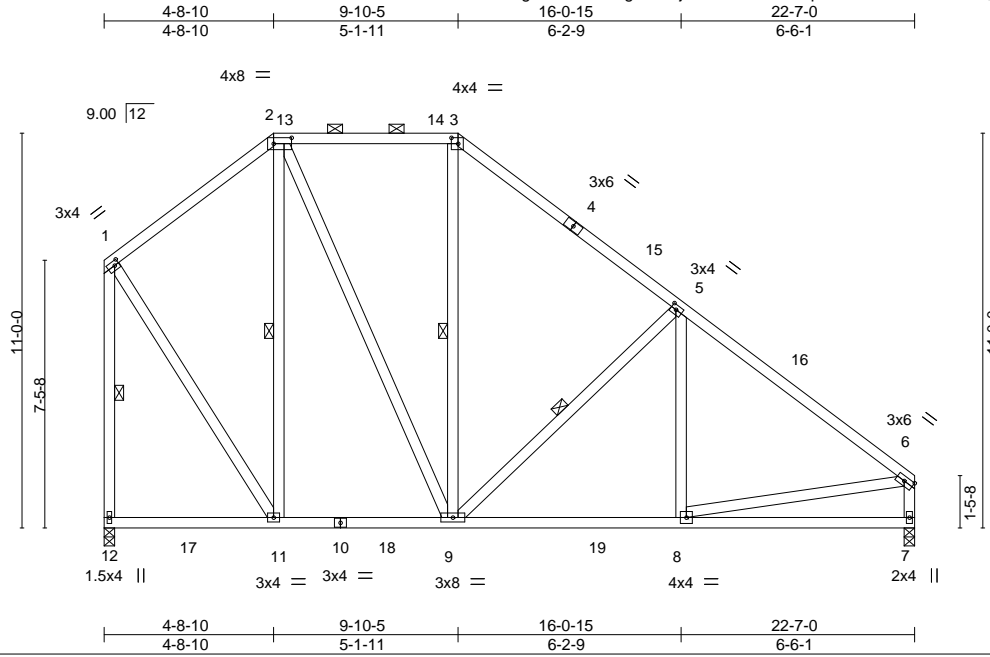

Scale: 3/16"=1'

Plate Offsets (X,Y)-- [1:0-1-8,0-1-8], [2:0-6-0,0-2-0], [3:0-2-4,0-2-0], [5:0-1-12,0-1-8], [6:Edge,0-1-8]

LOADING (psf)	SPACING-	CSI.	DEFL.	PLATES	GRIP
TCLL (roof) 20.0	2-0-0	TC 0.52	in (loc) l/defl L/d	MT20	244/190
Snow (Pf/Pg) 16.5/15.0	Plate Grip DOL 1.15	BC 0.35	Vert(LL) -0.05 8-9 >999 240		
TCDL 10.0	Lumber DOL 1.15	WB 0.33	Vert(CT) -0.09 8-9 >999 180		
BCLL 0.0 *	Rep Stress Incr YES	Matrix-S	Horz(CT) 0.01 7 n/a n/a		
BCDL 10.0	Code IRC2018/TPI2014			Weight: 177 lb	FT = 20%

LUMBER-	BRACING-
TOP CHORD 2x4 SP No.1	TOP CHORD Sheathed or 5-6-7 oc purlins, except end verticals, and 2-0-0 oc purlins (6-0-0 max.); 2-3.
BOT CHORD 2x4 SP No.1	BOT CHORD Rigid ceiling directly applied or 10-0-0 oc bracing.
WEBS 2x4 SP No.3	WEBS 1 Row at midpt 2-11, 3-9, 5-9, 1-12

REACTIONS. (size) 12=0-3-8, 7=0-3-8
 Max Horz 12=-284(LC 10)
 Max Uplift 12=-5(LC 12)
 Max Grav 12=1102(LC 44), 7=1046(LC 44)

FORCES. (lb) - Max. Comp./Max. Ten. - All forces 250 (lb) or less except when shown.
 TOP CHORD 1-2=-583/118, 2-3=-565/121, 3-5=-834/112, 5-6=-1181/40, 1-12=-1006/39, 6-7=-947/28
 BOT CHORD 9-11=0/469, 8-9=0/895
 WEBS 2-11=-386/82, 2-9=-39/502, 5-9=-543/92, 1-11=-15/718, 6-8=0/820

- NOTES-**
- Unbalanced roof live loads have been considered for this design.
 - Wind: ASCE 7-16; Vult=130mph (3-second gust) Vasd=103mph; TC DL=6.0psf; BC DL=6.0psf; h=12ft; B=45ft; L=24ft; eave=4ft; Cat. II; Exp B; Enclosed; MWFRS (directional); cantilever left and right exposed; end vertical left and right exposed; Lumber DOL=1.60 plate grip DOL=1.60
 - TCLL: ASCE 7-16; Pr=20.0 psf (roof LL: Lum DOL=1.15 Plate DOL=1.15); Pg=15.0 psf; Pf=16.5 psf (Lum DOL=1.15 Plate DOL=1.15); Is=1.0; Rough Cat B; Partially Exp.; Ce=1.0; Cs=1.00; Ct=1.10, Lu=50-0-0; Min. flat roof snow load governs. Rain surcharge applied to all exposed surfaces with slopes less than 0.500/12 in accordance with IBC 1608.3.4.
 - Unbalanced snow loads have been considered for this design.
 - Provide adequate drainage to prevent water ponding.
 - This truss has been designed for a 10.0 psf bottom chord live load nonconcurrent with any other live loads.
 - * This truss has been designed for a live load of 20.0psf on the bottom chord in all areas where a rectangle 3-6-0 tall by 2-0-0 wide will fit between the bottom chord and any other members, with BCDL = 10.0psf.
 - Provide mechanical connection (by others) of truss to bearing plate capable of withstanding 100 lb uplift at joint(s) 12.
 - This truss is designed in accordance with the 2018 International Residential Code sections R502.11.1 and R802.10.2 and referenced standard ANSI/TPI 1.
 - Graphical purlin representation does not depict the size or the orientation of the purlin along the top and/or bottom chord.

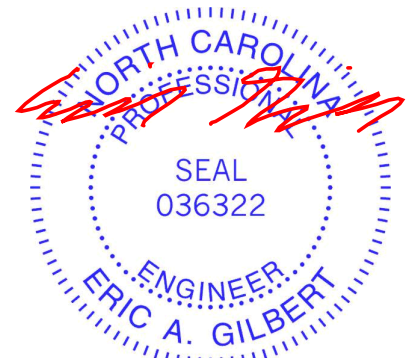

May 19, 2020

WARNING - Verify design parameters and READ NOTES ON THIS AND INCLUDED MITEK REFERENCE PAGE MII-7473 rev. 10/03/2015 BEFORE USE.
 Design valid for use only with MiTek® connectors. This design is based only upon parameters shown, and is for an individual building component, not a truss system. Before use, the building designer must verify the applicability of design parameters and properly incorporate this design into the overall building design. Bracing indicated is to prevent buckling of individual truss web and/or chord members only. Additional temporary and permanent bracing is always required for stability and to prevent collapse with possible personal injury and property damage. For general guidance regarding the fabrication, storage, delivery, erection and bracing of trusses and truss systems, see **ANSI/TPI1 Quality Criteria, DSB-89 and BCSI Building Component Safety Information** available from Truss Plate Institute, 218 N. Lee Street, Suite 312, Alexandria, VA 22314.



818 Soundside Road
 Edenton, NC 27932

Job	Truss	Truss Type	Qty	Ply	RICHARDSON	E14419891
P20-04027	T13	Piggyback Base Structural Gable COMMON I I Gable I Gable		1		

Longleaf Truss Company, West End, NC - 27376,

8.330 s Mar 23 2020 MiTek Industries, Inc. Tue May 19 07:21:25 2020 Page 2
 ID: gkUVx24QO5glBKvEjRcThWzF1?4-LOIB2jWggZXYWzNB997fmEp1XhApoByQEsA?uGzF?ou

- NOTES-**
- 14) This truss is designed in accordance with the 2018 International Residential Code sections R502.11.1 and R802.10.2 and referenced standard ANSI/TPI 1.
 - 15) Graphical purlin representation does not depict the size or the orientation of the purlin along the top and/or bottom chord.

WARNING - Verify design parameters and READ NOTES ON THIS AND INCLUDED MITEK REFERENCE PAGE MII-7473 rev. 10/03/2015 BEFORE USE.

Design valid for use only with MiTek® connectors. This design is based only upon parameters shown, and is for an individual building component, not a truss system. Before use, the building designer must verify the applicability of design parameters and properly incorporate this design into the overall building design. Bracing indicated is to prevent buckling of individual truss web and/or chord members only. Additional temporary and permanent bracing is always required for stability and to prevent collapse with possible personal injury and property damage. For general guidance regarding the fabrication, storage, delivery, erection and bracing of trusses and truss systems, see **ANSI/TPI1 Quality Criteria, DSB-89 and BCSI Building Component Safety Information** available from Truss Plate Institute, 218 N. Lee Street, Suite 312, Alexandria, VA 22314.



818 Soundside Road
 Edenton, NC 27932

Job	Truss	Truss Type	Qty	Ply	RICHARDSON	E14419893
P20-04027	T15	Piggyback Base	1	1	Job Reference (optional)	

Longleaf Truss Company,

West End, NC - 27376,

8.330 s Mar 23 2020 MiTek Industries, Inc. Tue May 19 07:21:30 2020 Page 1

ID: gkUVx24QO5glBKvEjRcThWzFI?4-iMY46RaoV59qdkF8yijqTlWoxinvTTT9O8umaTzF?op

1-2-8	5-7-15	11-0-5	16-4-12	20-6-11	24-8-11	30-8-0	36-7-6	42-6-11	48-9-5	55-3-6	56-5-14
1-2-8	5-7-15	5-4-7	5-4-7	4-2-0	4-2-0	5-11-5	5-11-5	5-11-5	6-2-9	6-6-1	1-2-8

Scale = 1:98.6

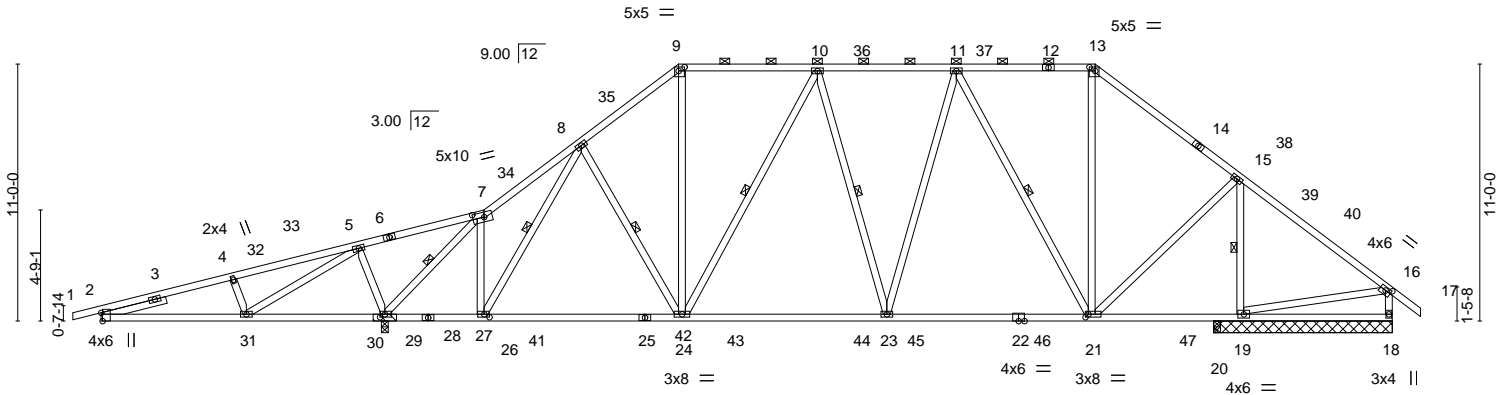

6-2-10	12-0-0	12-1-12	16-4-12	24-8-11	33-7-11	42-6-11	47-11-2	48-9-6	55-3-6
6-2-10	5-9-6	0-1-12	4-3-0	8-3-15	8-11-0	8-11-0	5-4-7	0-10-3	6-6-1

Plate Offsets (X,Y)-- [2:0-4-4,Edge], [7:0-5-12,0-2-8], [9:0-3-0,0-2-0], [13:0-3-0,0-2-0], [16:0-3-0,0-1-12], [21:0-1-8,0-1-8], [26:0-2-12,0-1-8], [29:0-2-8,0-1-8]

LOADING (psf)	SPACING-	CSI.	DEFL.	PLATES	GRIP
TCLL (roof) 20.0	Plate Grip DOL 1.15	TC 0.64	Vert(LL) -0.20 21-23 >999 240	MT20	244/190
Snow (Pf/Pg) 16.5/15.0	Lumber DOL 1.15	BC 0.70	Vert(CT) -0.32 21-23 >999 180		
TCDL 10.0	Rep Stress Incr YES	WB 0.79	Horz(CT) 0.04 18 n/a n/a		
BCLL 0.0 *	Code IRC2018/TPI2014	Matrix-S			
BCDL 10.0				Weight: 368 lb	FT = 20%

LUMBER-	BRACING-
TOP CHORD 2x4 SP No.1	TOP CHORD Sheathed or 5-3-8 oc purlins, except end verticals, and 2-0-0 oc purlins (5-3-6 max.): 9-13.
BOT CHORD 2x4 SP No.1	BOT CHORD Rigid ceiling directly applied or 4-5-5 oc bracing.
WEBS 2x4 SP No.3	WEBS 1 Row at midpt 7-29, 8-26, 8-24, 10-24, 10-23, 11-21, 15-19
SLIDER Left 2x4 SP No.3 -x 2-10-5	

REACTIONS. All bearings 0-3-8 except (jt=length) 29=0-4-10 (input: 0-3-8 + bearing block), 19=7-7-12, 18=7-7-12.
 (lb) - Max Horz 29=236(LC 11)
 Max Uplift All uplift 100 lb or less at joint(s) 18, 20 except 29=286(LC 12)
 Max Grav All reactions 250 lb or less at joint(s) 18, 20 except 29=2937(LC 27), 19=2005(LC 25)

FORCES. (lb) - Max. Comp./Max. Ten. - All forces 250 (lb) or less except when shown.
 TOP CHORD 2-4=-242/906, 4-5=-230/1021, 5-7=-452/2136, 7-8=-785/457, 8-9=-1429/2,
 9-10=-1143/24, 10-11=-1329/60, 11-13=-788/105, 13-15=-1004/90, 15-16=-65/283
 BOT CHORD 2-31=-820/241, 29-31=-1835/470, 26-29=-310/732, 24-26=0/1112, 23-24=0/1417,
 21-23=0/1274
 WEBS 4-31=-407/95, 5-31=-236/1075, 5-29=-686/149, 7-29=-3048/193, 7-26=-171/1467,
 8-26=-1385/301, 8-24=-97/402, 9-24=0/581, 10-24=-539/79, 11-23=0/481,
 11-21=-1014/0, 13-21=0/311, 15-21=0/1291, 15-19=-1719/0, 16-19=-280/75

- NOTES-**
- 2x4 SP No.1 bearing block 12" long at jt. 29 attached to front face with 2 rows of 10d (0.131"x3") nails spaced 3" o.c. 8 Total fasteners. User Defined Bearing crushing capacity= 425psi.
 - Unbalanced roof live loads have been considered for this design.
 - Wind: ASCE 7-16; Vult=130mph (3-second gust) Vasd=103mph; TC DL=6.0psf; BCDL=6.0psf; h=12ft; B=45ft; L=55ft; eave=7ft; Cat. II; Exp B; Enclosed; MWFRS (directional); cantilever left and right exposed ; end vertical left and right exposed; Lumber DOL=1.60 plate grip DOL=1.60
 - TCLL: ASCE 7-16; Pr=20.0 psf (roof LL: Lum DOL=1.15 Plate DOL=1.15); Pg=15.0 psf; Pf=16.5 psf (Lum DOL=1.15 Plate DOL=1.15); Is=1.0; Rough Cat B; Partially Exp.; Ce=1.0; Cs=1.00; Ct=1.10, Lu=50-0-0; Min. flat roof snow load governs. Rain surcharge applied to all exposed surfaces with slopes less than 0.500/12 in accordance with IBC 1608.3.4.
 - Unbalanced snow loads have been considered for this design.
 - This truss has been designed for greater of min roof live load of 12.0 psf or 1.00 times flat roof load of 11.6 psf on overhangs non-concurrent with other live loads.
 - Provide adequate drainage to prevent water ponding.
 - All plates are 3x6 MT20 unless otherwise indicated.
 - This truss has been designed for a 10.0 psf bottom chord live load nonconcurrent with any other live loads.
 - * This truss has been designed for a live load of 20.0psf on the bottom chord in all areas where a rectangle 3-6-0 tall by 2-0-0 wide will fit between the bottom chord and any other members, with BCDL = 10.0psf.
 - Provide mechanical connection (by others) of truss to bearing plate capable of withstanding 100 lb uplift at joint(s) 18, 20 except (jt=lb) 29=286.
 - This truss is designed in accordance with the 2018 International Residential Code sections R502.11.1 and R802.10.2 and

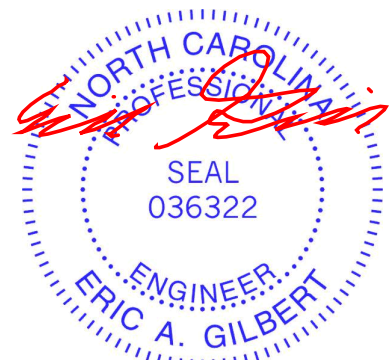

Continue on page 2
WARNING - Verify design parameters and READ NOTES ON THIS AND INCLUDED MITEK REFERENCE PAGE MII-7473 rev. 10/03/2015 BEFORE USE.
 Design valid for use only with MiTek® connectors. This design is based only upon parameters shown, and is for an individual building component, not a truss system. Before use, the building designer must verify the applicability of design parameters and properly incorporate this design into the overall building design. Bracing indicated is to prevent buckling of individual truss web and/or chord members only. Additional temporary and permanent bracing is always required for stability and to prevent collapse with possible personal injury and property damage. For general guidance regarding the fabrication, storage, delivery, erection and bracing of trusses and truss systems, see **ANSI/TPI1 Quality Criteria, DSB-89 and BCSI Building Component Safety Information** available from Truss Plate Institute, 218 N. Lee Street, Suite 312, Alexandria, VA 22314.

ENGINEERING BY
TRENCO
 A MiTek Affiliate
 818 Soundside Road
 Edenton, NC 27932

Job	Truss	Truss Type	Qty	Ply	RICHARDSON	E14419893
P20-04027	T15	Piggyback Base	1	1	Job Reference (optional)	

Longleaf Truss Company, West End, NC - 27376,

8.330 s Mar 23 2020 MiTek Industries, Inc. Tue May 19 07:21:30 2020 Page 2
 ID:gkUVx24QO5glBKvEjRcThWzFI?4-iMY46RaoV59qdkF8yjjqTIWoxinvTTT9O8umaTzF?op

NOTES-

13) Graphical purlin representation does not depict the size or the orientation of the purlin along the top and/or bottom chord.

WARNING - Verify design parameters and READ NOTES ON THIS AND INCLUDED MITEK REFERENCE PAGE MII-7473 rev. 10/03/2015 BEFORE USE.

Design valid for use only with MiTek® connectors. This design is based only upon parameters shown, and is for an individual building component, not a truss system. Before use, the building designer must verify the applicability of design parameters and properly incorporate this design into the overall building design. Bracing indicated is to prevent buckling of individual truss web and/or chord members only. Additional temporary and permanent bracing is always required for stability and to prevent collapse with possible personal injury and property damage. For general guidance regarding the fabrication, storage, delivery, erection and bracing of trusses and truss systems, see **ANSI/TPI1 Quality Criteria, DSB-89 and BCS1 Building Component Safety Information** available from Truss Plate Institute, 218 N. Lee Street, Suite 312, Alexandria, VA 22314.



818 Soundside Road
 Edenton, NC 27932

Job	Truss	Truss Type	Qty	Ply	RICHARDSON	E14419894
P20-04027	T17	Piggyback Base Girder	1	1	Job Reference (optional)	

Longleaf Truss Company, West End, NC - 27376,

8.330 s Mar 23 2020 MiTek Industries, Inc. Tue May 19 07:21:33 2020 Page 1

ID: gkUVx24QO5glBKvEjRcThWzF1?4-6xEDkTchn0XPUB_jdqGX5w8M7vyGgxHb456QAozF?om

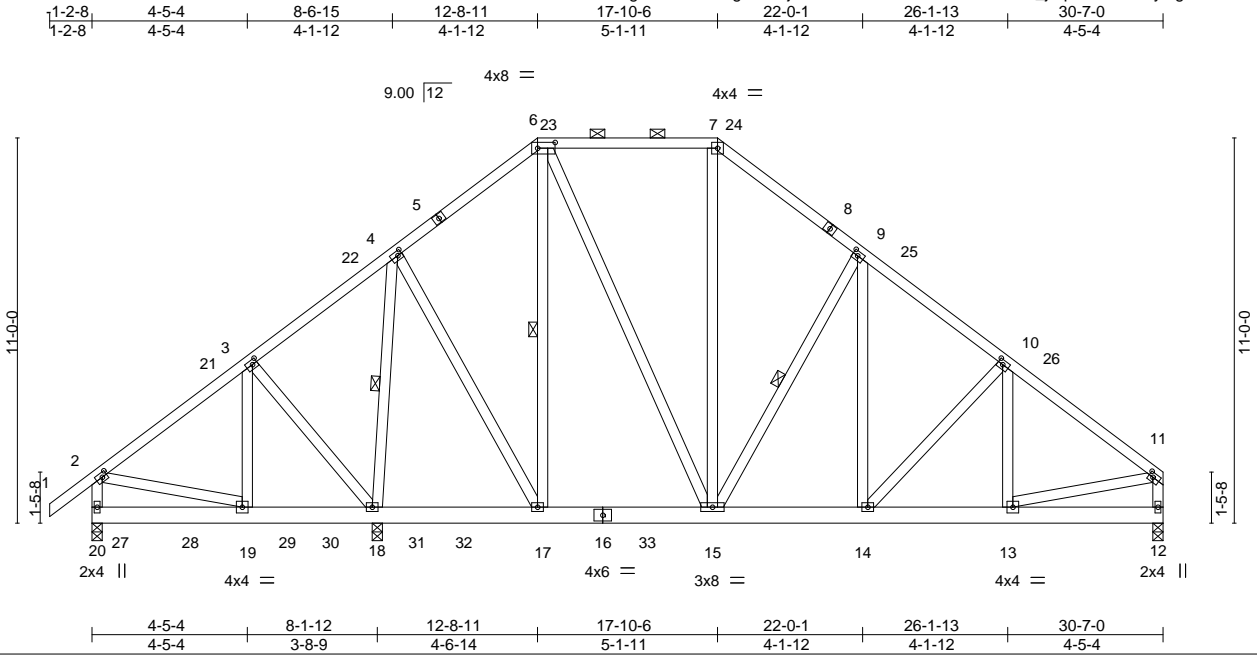

Scale = 1:65.8

Plate Offsets (X,Y)-- [2:0-1-12,0-1-8], [3:0-1-12,0-1-8], [4:0-1-8,0-1-8], [6:0-6-0,0-2-0], [9:0-1-12,0-1-8], [10:0-1-12,0-1-8], [11:0-1-8,0-1-8]

LOADING (psf)	SPACING-	CSI.	DEFL.	PLATES	GRIP
TCLL (roof) 20.0	2-0-0	TC 0.45	in (loc) l/defl L/d	MT20	244/190
Snow (Pf/Pg) 16.5/15.0	Plate Grip DOL 1.15	BC 0.15	Vert(LL) -0.03 14 >999 240		
TCDL 10.0	Lumber DOL 1.15	WB 0.34	Vert(CT) -0.05 14 >999 180		
BCLL 0.0 *	Rep Stress Incr NO	Matrix-S	Horz(CT) 0.01 12 n/a n/a		
BCDL 10.0	Code IRC2018/TPI2014			Weight: 265 lb	FT = 20%

LUMBER-	BRACING-
TOP CHORD 2x4 SP No.1	TOP CHORD Sheathed or 5-9-5 oc purlins, except end verticals, and 2-0-0 oc purlins (6-0-0 max.): 6-7.
BOT CHORD 2x6 SP No.1	BOT CHORD Rigid ceiling directly applied or 10-0-0 oc bracing.
WEBS 2x4 SP No.3	WEBS 1 Row at midpt 4-18, 6-17, 9-15

REACTIONS. (size) 20=0-3-8, 18=0-3-8, 12=0-3-8
 Max Horz 20=240(LC 11)
 Max Uplift 20=32(LC 12), 18=58(LC 12)
 Max Grav 20=732(LC 2), 18=1628(LC 98), 12=1064(LC 45)

FORCES. (lb) - Max. Comp./Max. Ten. - All forces 250 (lb) or less except when shown.
 TOP CHORD 2-3=-511/23, 4-6=-625/123, 6-7=-599/123, 7-9=-824/124, 9-10=-1089/80,
 10-11=-1172/31, 2-20=-544/43, 11-12=-984/18
 BOT CHORD 19-20=-215/264, 18-19=-81/443, 15-17=0/462, 14-15=0/779, 13-14=0/871
 WEBS 3-19=-12/301, 3-18=-455/83, 4-18=-1010/35, 4-17=0/550, 6-17=-313/5, 6-15=-11/450,
 9-15=-515/83, 9-14=0/270, 2-19=-1/329, 11-13=0/835

- NOTES-**
- Unbalanced roof live loads have been considered for this design.
 - Wind: ASCE 7-16; Vult=130mph (3-second gust) Vasd=103mph; TCdL=6.0psf; BCDL=6.0psf; h=12ft; B=45ft; L=31ft; eave=4ft; Cat. II; Exp B; Enclosed; MWFRS (directional); cantilever left and right exposed ; end vertical left and right exposed; Lumber DOL=1.60 plate grip DOL=1.60
 - TCLL: ASCE 7-16; Pr=20.0 psf (roof LL: Lum DOL=1.15 Plate DOL=1.15); Pg=15.0 psf; Pf=16.5 psf (Lum DOL=1.15 Plate DOL=1.15); Is=1.0; Rough Cat B; Partially Exp.; Ce=1.0; Cs=1.00; Ct=1.10, Lu=50-0-0 Rain surcharge applied to all exposed surfaces with slopes less than 0.500/12 in accordance with IBC 1608.3.4.
 - Unbalanced snow loads have been considered for this design.
 - This truss has been designed for greater of min roof live load of 12.0 psf or 1.00 times flat roof load of 11.6 psf on overhangs non-concurrent with other live loads.
 - Provide adequate drainage to prevent water ponding.
 - All plates are 3x4 MT20 unless otherwise indicated.
 - This truss has been designed for a 10.0 psf bottom chord live load nonconcurrent with any other live loads.
 - * This truss has been designed for a live load of 20.0psf on the bottom chord in all areas where a rectangle 3-6-0 tall by 2-0-0 wide will fit between the bottom chord and any other members, with BCDL = 10.0psf.
 - Provide mechanical connection (by others) of truss to bearing plate capable of withstanding 100 lb uplift at joint(s) 20, 18.
 - This truss is designed in accordance with the 2018 International Residential Code sections R502.11.1 and R802.10.2 and referenced standard ANSI/TPI 1.
 - Graphical purlin representation does not depict the size or the orientation of the purlin along the top and/or bottom chord.
 - Hanger(s) or other connection device(s) shall be provided sufficient to support concentrated load(s) 129 lb down and 17 lb up at 0-9-11, 125 lb down and 20 lb up at 2-9-11, and 125 lb down and 20 lb up at 4-9-11, and 125 lb down and 20 lb up at 6-9-11 on bottom chord. The design/selection of such connection device(s) is the responsibility of others.



May 19, 2020

LOAD CASE(S) Standard

WARNING - Verify design parameters and READ NOTES ON THIS AND INCLUDED MITEK REFERENCE PAGE MII-7473 rev. 10/03/2015 BEFORE USE.
 Design valid for use only with MiTek® connectors. This design is based only upon parameters shown, and is for an individual building component, not a truss system. Before use, the building designer must verify the applicability of design parameters and properly incorporate this design into the overall building design. Bracing indicated is to prevent buckling of individual truss web and/or chord members only. Additional temporary and permanent bracing is always required for stability and to prevent collapse with possible personal injury and property damage. For general guidance regarding the fabrication, storage, delivery, erection and bracing of trusses and truss systems, see **ANSI/TPI1 Quality Criteria, DSB-89 and BCSI Building Component Safety Information** available from Truss Plate Institute, 218 N. Lee Street, Suite 312, Alexandria, VA 22314.



818 Soundside Road
 Edenton, NC 27932

Job	Truss	Truss Type	Qty	Ply	RICHARDSON	E14419894
P20-04027	T17	Piggyback Base Girder	1	1	Job Reference (optional)	

Longleaf Truss Company, West End, NC - 27376,

8.330 s Mar 23 2020 MiTek Industries, Inc. Tue May 19 07:21:33 2020 Page 2
 ID:gkUVx24QO5glBKvEjRcThWzFI?4-6xEDkTchn0XPUB_jdqGX5w8M7vyGgxHb456QAozF?om

LOAD CASE(S) Standard

- 1) Dead + Snow (balanced): Lumber Increase=1.15, Plate Increase=1.15
- Uniform Loads (plf)
 - Vert: 1-2=-43, 2-6=-43, 6-7=-53, 7-11=-43, 12-20=-20
- Concentrated Loads (lb)
 - Vert: 27=-107 28=-104 29=-104 30=-104

WARNING - Verify design parameters and READ NOTES ON THIS AND INCLUDED MITEK REFERENCE PAGE MII-7473 rev. 10/03/2015 BEFORE USE.

Design valid for use only with MiTek® connectors. This design is based only upon parameters shown, and is for an individual building component, not a truss system. Before use, the building designer must verify the applicability of design parameters and properly incorporate this design into the overall building design. Bracing indicated is to prevent buckling of individual truss web and/or chord members only. Additional temporary and permanent bracing is always required for stability and to prevent collapse with possible personal injury and property damage. For general guidance regarding the fabrication, storage, delivery, erection and bracing of trusses and truss systems, see **ANSI/TPI1 Quality Criteria, DSB-89 and BCSI Building Component Safety Information** available from Truss Plate Institute, 218 N. Lee Street, Suite 312, Alexandria, VA 22314.



818 Soundside Road
 Edenton, NC 27932

Symbols

PLATE LOCATION AND ORIENTATION

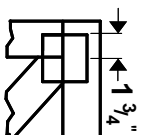

Center plate on joint unless x, y offsets are indicated. Dimensions are in ft-in-sixteenths. Apply plates to both sides of truss and fully embed teeth.

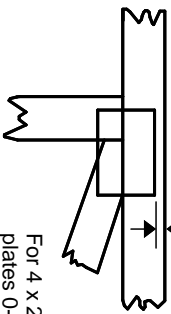

For 4 x 2 orientation, locate plates 0- 1/16" from outside edge of truss.



This symbol indicates the required direction of slots in connector plates.

* Plate location details available in **MITrak 20/20 software or upon request.**

PLATE SIZE

4 X 4

The first dimension is the plate width measured perpendicular to slots. Second dimension is the length parallel to slots.

LATERAL BRACING LOCATION

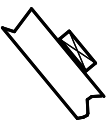

Indicated by symbol shown and/or by text in the bracing section of the output. Use T or I bracing if indicated.

BEARING

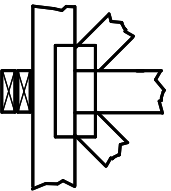

Indicates location where bearings (supports) occur. Icons vary but reaction section indicates joint number where bearings occur. Min size shown is for crushing only.

Industry Standards:

ANSI/TPI 1: National Design Specification for Metal Plate Connected Wood Truss Construction.
DSB-89: Design Standard for Bracing.
BCSI: Building Component Safety Information, Guide to Good Practice for Handling, Installing & Bracing of Metal Plate Connected Wood Trusses.

Numbering System

6-4-8
dimensions shown in ft-in-sixteenths
(Drawings not to scale)

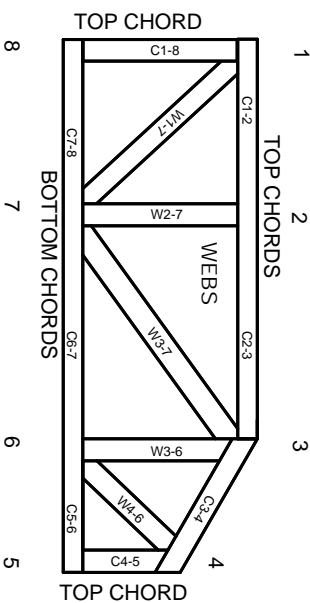

JOINTS ARE GENERALLY NUMBERED/LETTERED CLOCKWISE AROUND THE TRUSS STARTING AT THE JOINT FARTHEST TO THE LEFT.

CHORDS AND WEBS ARE IDENTIFIED BY END JOINT NUMBERS/LETTERS.

PRODUCT CODE APPROVALS

ICC-ES Reports:

ESR-1311, ESR-1352, ESR1988
ER-3907, ESR-2362, ESR-1397, ESR-3282

Trusses are designed for wind loads in the plane of the truss unless otherwise shown.

Lumber design values are in accordance with ANSI/TPI 1 section 6.3 These truss designs rely on lumber values established by others.

© 2012 MITTEK® All Rights Reserved



MITek Engineering Reference Sheet: MII-7473 rev. 10/03/2015



General Safety Notes

Failure to Follow Could Cause Property Damage or Personal Injury

1. Additional stability bracing for truss system, e.g. diagonal or X-bracing, is always required. See BCSI.
2. Truss bracing must be designed by an engineer. For wide truss spacing, individual lateral braces themselves may require bracing, or alternative Tor I bracing should be considered.
3. Never exceed the design loading shown and never stack materials on inadequately braced trusses.
4. Provide copies of this truss design to the building designer, erection supervisor, property owner and all other interested parties.
5. Cut members to bear tightly against each other.
6. Place plates on each face of truss at each joint and embed fully. Knots and wane at joint locations are regulated by ANSI/TPI 1.
7. Design assumes trusses will be suitably protected from the environment in accord with ANSI/TPI 1.
8. Unless otherwise noted, moisture content of lumber shall not exceed 19% at time of fabrication.
9. Unless expressly noted, this design is not applicable for use with fire retardant, preservative treated, or green lumber.
10. Camber is a non-structural consideration and is the responsibility of truss fabricator. General practice is to camber for dead load deflection.
11. Plate type, size, orientation and location dimensions indicated are minimum plating requirements.
12. Lumber used shall be of the species and size, and in all respects, equal to or better than that specified.
13. Top chords must be sheathed or purlins provided at spacing indicated on design.
14. Bottom chords require lateral bracing at 10 ft. spacing, or less, if no ceiling is installed, unless otherwise noted.
15. Connections not shown are the responsibility of others.
16. Do not cut or alter truss member or plate without prior approval of an engineer.
17. Install and load vertically unless indicated otherwise.
18. Use of green or treated lumber may pose unacceptable environmental, health or performance risks. Consult with project engineer before use.
19. Review all portions of this design (front, back, words and pictures) before use. Reviewing pictures alone is not sufficient.
20. Design assumes manufacture in accordance with ANSI/TPI 1 Quality Criteria.