

Lot 1080 - Anderson Creek Academy



ELEVATION - CLASSIC

1) PLANS HAVE BEEN ISSUED TO MCKEE HOMES LLC. AS A BASE PLAN MASTER SET.
 2) PLANS AND OPTIONS ARE DESIGNED FOR SINGLE USE ONLY AND NOT IN COMBINATION WITH EACH OTHER. THE USE OF MULTIPLE OPTIONS TOGETHER MAY CAUSE ADDITIONAL CHANGES TO ORIGINAL STRUCTURE AND ARCHITECTURAL DESIGNS.
 3. ANY ON SITE CHANGES OR VARIATIONS FROM PLANS SHOWN MUST BE VERIFIED WITH DESIGNER OR ENGINEER TO MEET LOCAL CODES, GUIDELINES, LOAD CALCULATIONS ETC.



ELEVATION - EURO

BROOKS II - EURO	
Heated Square Footage	
First Floor	1329
Second Floor	1618
Total	2947
Unheated Square Footage	
Covered Porch - Front	133
Garage (Front Load)	491
Garage (Side Load Opt.)	491
Patio - Rear	221
Walk-up Attic (Unf. Mech)	115
Walk-up Attic (5/10 Cig.) (Opt. Finished or Unfin)	530

IF ATTIC STAIR DOOR IS AT TOP ADD ADDITIONAL 34 SQ. FEET

OWNER / CONTRACTOR NOTES:

- THE SEALING OF THIS PLAN FOR A LOT SPECIFIC ISSUE, AUTHORIZES THE CONSTRUCTION FROM THESE PLANS FOR ONE HOUSE ON ONE LOT FOR THE LOT SPECIFIC REFERENCED IN TITLEBLOCK. UNSEALED PLANS MUST NOT BE USED FOR CONSTRUCTION. CONSTRUCTION FROM THESE PLANS MUST BE FROM THE LATEST APPROVED DATE PLANS, INCLUDING REVISIONS AND ADDENDA.
- THE SEALING OF THIS PLAN FOR A MASTER PLAN SET ISSUE, AUTHORIZES THE CONSTRUCTION FROM THESE PLANS FOR MULTIPLE HOUSES ON MULTIPLE LOTS PER BUILDER WITH DESIGNER'S KNOWLEDGE OF CONSTRUCTION PER LOT. UNSEALED PLANS MUST NOT BE USED FOR CONSTRUCTION. CONSTRUCTION FROM THESE PLANS MUST BE FROM THE LATEST APPROVED DATE PLANS, INCLUDING REVISIONS AND ADDENDA.
- CONSTRUCTION DEVIATING FROM THESE PLANS WILL INVALIDATE THEIR PLANS REVIEW PERMITTED USE. THE DESIGNER MUST BE NOTIFIED IMMEDIATELY OF CONSTRUCTION DEVIATING FROM DEPICTED OR IMPLIED INFORMATION HEREIN. LETTER FROM THE DESIGNER MAY BE OBTAINED FOR A FEE TO VERIFY THE FEASIBILITY AND COMPLIABILITY OF ANY CHANGES. HOWEVER, THE OWNER/CONTRACTOR ASSUMES ALL RISK FROM DEVIATING FROM THESE PLANS.
- DO NOT SCALE DRAWINGS, BUT RATHER INQUIRE INFORMATION FROM DESIGNER. REPRODUCTION OF THESE DRAWINGS ARE PROHIBITED UNLESS GRANTED WRITTEN CONSENT FROM DESIGNER.
- THE OWNER AND/OR CONTRACTOR IS RESPONSIBLE FOR OBTAINING THE FOLLOWING INFORMATION (NON-EXHAUSTIVE): BUILDING PERMITS, SITE ENGINEERING INCLUDING SURVEYING, TOPOGRAPHIC STUDIES, GEOTECHNICAL REPORTS, AND SEPTIC PERMITS; INTERIOR CASEWORK DESIGN; PLUMBING, MECHANICAL, AND ELECTRICAL DESIGN.

BUILDING CODE NOTES

THIS PLAN HAS BEEN DESIGNED UNDER THE 2018 NORTH CAROLINA RESIDENTIAL CODE.

- APPLICABLE CODES:
 N.C. FIRE CODE, 2018
 N.C. MECHANICAL CODE, 2018
 N.C. PLUMBING CODE, 2018
 N.C. ENERGY CODE, 2018
 N.C. ELECTRICAL CODE, 2017
 N.C. GAS CODE 2018

BUILDING DATA:

Construction Type:	V-2B
Use Group:	R-3
Number of Stories:	[2]
Building Ridge Height: (Elevation A) +	(N/A) 32'-3"
Building Ridge Height: (Elevation B) +	(N/A) 32'-3"
Building Ridge Height: (Elevation C) +	(N/A)
Building Ridge Height: (Elevation D) +	(N/A) 32'-3"
Building Ridge Height: (Elevation E) +	(N/A) 32'-3"
Mean Roof Height: (Elevation A) +	(N/A) 25'-8"
Mean Roof Height: (Elevation B) +	(N/A) 25'-8"
Mean Roof Height: (Elevation C) +	(N/A)
Mean Roof Height: (Elevation D) +	(N/A) 25'-8"
Mean Roof Height: (Elevation E) +	(N/A) 25'-8"

NOTE: HEIGHTS LISTED ABOVE ARE BASED ON MONO SLAB GRADE LINES PROVIDED ON EXTERIOR ELEVATIONS SHEETS. BUILDER / INSPECTORS OFFICIAL TO VERIFY FINAL GRADE HEIGHT IN FIELD AS REQUIRED.

CONSTRUCTION NOTES:

- THE FOLLOWING IS A NON-EXHAUSTIVE LIST OF SOME COMMONLY MISSED CODE REQUIREMENTS AND ARE ENFORCEABLE IN THE CONSTRUCTION FROM THESE PLANS. SEE THE N.C. RESIDENTIAL CODE BOOK FOR MORE INFO.
- (R308.4) ALL GLAZING WITHIN 24" OF EITHER SIDE OF A DOOR IN A CLOSED POSITION, AND ON THE SAME WALL PLANE SHALL BE TEMPERED. ALL WINDOWS THAT MEET ALL OF THE FOLLOWING CONDITIONS SHALL BE TEMPERED: A) INDIVIDUAL PANES OF MIN. 9 SF. B) BOTTOM EDGE IS WITHIN 18" OF FLOOR. C) TOP EDGE IS AT LEAST 36" ABOVE FLOOR. AND D) GLAZING IS WITHIN 36" HORIZ. OF WALKING SURFACE. TEMPERED GLAZING IS ALSO REQUIRED WITHIN 60" OF HOT TUBS OR STAIR LEADING AND FINISH EDGES. TEMPERED WINDOWS ALSO REQUIRED PER REMAINDER OF THIS CODE SECTION.
 - (R310.1) ALL SLEEPING ROOMS AND BASEMENTS WITH HABITABLE SPACE SHALL HAVE AT LEAST ONE EGRESS WINDOW CONFORMING TO THE FOLLOWING: A) MIN. 4.0 SF. CLEAR OPENING; B) MIN. TOTAL GLASS AREA OF 5.0 SQ (GROUND FLOOR WINDOW) AND 5.7 SF (UPPER STORY WINDOW). IT IS THE CONTRACTOR'S RESPONSIBILITY TO CHOOSE THE PROPER CONFORMING WINDOW AND HAVE EGRESS WINDOWS PROPERLY DISTRIBUTED AND INSTALLED AS REQUIRED.
 - (R311.2) ALL INTERIOR EGRESS DOORS AND A MINIMUM OF ONE EXTERIOR EGRESS DOOR SHALL BE READILY OPENABLE FROM THE EGRESS SIDE WITHOUT USE OF A KEY OR SPECIAL KNOWLEDGE.
 - (R311.15) MAXIMUM STAIR RISER HEIGHT SHALL BE 8-1/4", AND MINIMUM TREAD SHALL BE 9".
 - (R314.3) SMOKE ALARMS SHALL BE INSTALLED AND INTERCONNECTED, WITH BATTERY BACK-UP IN THE FOLLOWING AREAS: EACH SLEEPING ROOM; IN THE AREA (HALLWAY) RIGHT OUTSIDE THE SLEEPING ROOMS; AND EACH STORY. THE ONE OUTSIDE THE SLEEPING ROOMS WILL SATISFY THAT STORY.
 - (R402.12) ALL LUMBER SHALL BE PRESSURE TREATED AND DRIED AFTER TREATMENT IN ACCORDANCE WITH AWWA U1 AND SHALL BEAR THE LABEL OF AN ACCREDITED AGENCY.
 - (R406.1) BITUMINOUS DAMPROOFING SHALL BE APPLIED TO EXTERIOR FOUNDATIONS OF ALL HABITABLE AND USABLE (STORAGE, ETC.) SPACES.
 - (R408.12) INSTALL ONE FOUNDATION VENT WITHIN 3' OF EACH CORNER (NOT ONE EACH SIDE OF EACH CORNER).
 - (R109.4) FLASH ALL VALLEYS AND WALL/ROOF INTERSECTIONS, AND CHIMNEY AND OTHER ROOF PENETRATIONS. USE ICE AND WATER SHIELD ON ALL ROOFS LESS THAN 4:12 SLOPE. FLASHING TO BE NON-CORROSIVE.
 - (R801.1) BUILDER TO LOCATE 22"x30" ATTIC ACCESS IN ALL ATTICS WITHOUT STAIR ACCESS. LOCATE ACCESS TO PROVIDE A 30" CLEAR SPACE ABOVE ACCESS DOOR-TYP.
 - (R100.1) MASONRY FIREPLACE WALLS TO BE MIN. 8" THICK AND MIN. 2" TO FRAMING. FOURED HEARTH TO HAVE MIN. 4#12" O.C. EACH WAY. HEARTH TO BE MIN. 20" FROM FIREBOX AND HAVE MIN. 12" WIDER THAN FIREBOX ON EACH SIDE.
 - (R403.1.6) ANCHOR BOLTS SHALL BE MIN. 1/2" DIAMETER & SHALL EXTEND A MINIMUM 1" INTO MASONRY OR CONCRETE. ANCHOR BOLTS TO BE NO MORE THAN 6" O.C. AND WITHIN 3' OF CORNER.
 - (R315) INSTALL APPROVED CARBON MONOXIDE ALARM OUTSIDE EACH BEDROOM AND IN IMMEDIATE VICINITY OF EACH SEPARATE SLEEPING AREA.
 - ALL WINDOWS SHALL BE LABELED TO CONFORM WITH AANHANUUDA 1018.2 BUILDER TO VERIFY MIN. DP CLASSIFICATION FOR ALL WINDOWS BASED ON LOCATION. SINGLE HOMES ARE BUILT BASED ON REQUIREMENTS FOR THAT WINDOW ZONE AREA.
 - IF CRAWL SPACE FOUNDATION OPTION IS USED BUILDER TO LOCATE ACCESS PER CURRENT CODE REQ. WITH 36"x24" (MIN) CLEAR OPENING IF NO HVAC LOCATED IN CRAWL OR 36"x36" (MIN) WITH HVAC LOCATED IN CRAWL SPACE AREA.

CLIMATIC AND GEOGRAPHIC NOTES:

TABLE N10212 (R40212)						
CLIMATE ZONE	FENESTRATION U-FACTOR	FENEST. SHGC	CEILING R-VALUE	FRAME WALL R-VALUE	FLOOR R-VALUE	BASEMENT WALL R-VALUE
3	0.35	0.30	38 OR 30 CONT.	15, 13-2.5	15	5/13
4	0.35	0.30	38 OR 30 CONT.	15, 13-2.5	15	10/15
5	0.35	NR	38 OR 30 CONT.	15, 13-5	30	10/15

STRUCTURAL DESIGN FIRM DATA:

STRUCTURAL DESIGNER	FIRM NAME	TELEPHONE NUMBER
Engineering Tech Associates	Engineering Tech Associates	919-844-1661
ENGINEER NAME	ENGINEER NAME	LICENSE NUMBER
---	---	C-3810

NOTE: PLANS ARE TO BE COORDINATED WITH STRUCTURAL DESIGNS AND TRUSS PLANS BY BUILDER. THE COORDINATION AND/OR VERIFICATION OF ANY STRUCTURAL MEMBERS, TRUSS PLANS AND/OR INFORMATION FROM OTHERS IS NOT THE RESPONSIBILITY OF PLAN DESIGNER. IF ANY DISCREPANCIES WITH FLOOR PLANS, ELEVATIONS OR DETAILS ARE DISCOVERED THE BUILDER SHALL NOTIFY PLANWORK PRIOR TO SUBMITTING PLANS FOR PERMIT OR BEFORE CONSTRUCTION BEGINS TO ADJUST PLANS AS NEEDED TO MEET NEEDS.

PROJECT SQUARE FOOTAGES

BROOKS II - CLASSIC	
Heated Square Footage	
First Floor	1329
Second Floor	1638
Total	2967
Unheated Square Footage	
Covered Porch - Front	133
Garage (Front Load)	491
Garage (Side Load Opt.)	502
Patio - Rear	221
Walk-up Attic (Unf. Mech)	115
Walk-up Attic (5/10 Cig.) (Opt. Finished or Unfin)	530

IF ATTIC STAIR DOOR IS AT TOP ADD ADDITIONAL 34 SQ. FEET

OPT. CRAWL SPACE VENTILATION INFO.

Crawlspace Vent Calculations - Brooks II - Classic		
A	Crawl Space Area	1,329
B	Ventable Area Required by Code (without vapor barrier)	8.86
C	Ventable Area Required by Code (with vapor barrier)	0.9
D	Number of vents required (without vapor barrier)	19.0
E	Number of vents required (with vapor barrier). (See notes)	2.0

Formulas:
 B = A / 150
 C = A / 1500
 D = B / 0.47 (sqft of net venting area per vent)
 E = C / 0.47 (sqft of net venting area per vent)

Notes:
 1. Builder must adjust ventilation calculations if using vents with a net area that is different than 0.47 sqft per vent.
 2. One foundation vent must be placed within 3 feet of each major corner in the building.
 3. Foundation vents must be placed to allow for cross ventilation.

NOTE: BUILDER TO SIZE AND LOCATE FOUNDATION VENTS IS USED PER THE 2018 N.C. RESIDENTIAL BUILDING CODE BASED ON SITE CONDITIONS.
 OR OPT. CLOSED CRAWL SPACE

NOT APPLICABLE ON THIS ARCHITECTURAL BASE MASTER PLAN SET - SEE STRUCTURAL FILES

NOTE: IF SEALED CRAWLSPACE SYSTEM IS USED AREA MUST BE CONSTRUCTED PER THE 2018 N.C. RESIDENTIAL BUILDING CODE.

ROOF VENTILATION INFO.

Roof Ventilation - Brooks II - Classic		
A	Ceiling area (square footage)	1,953
B	Sqft. of ventilation required	13.0

Formulas: B = A / 150

Notes:
 Builder to calculate quantities and types of vents to make up the minimum requirement. Attic ventilation shall be approximately 50% soffit, and 50% high (gable end or ridge vents).

INDEX OF DRAWINGS:

SHEET	SHEET NAME - Brooks II - Master Plan
CS-1-0	Cover Sheet
CS-1-1	Cover Sheet - High Wind Zone
A-1-0	Elevations - Front and Right - Classic
A-2-0	Elevations - Rear and Left - Classic
A-3-0	Wall Section Details
A-4-0	First Floor Plan
A-5-0	Second Floor Plan
A-6-0	Attic Floor Plan
AE-1-0	First & Second Floor Lighting
AE-2-0	Attic and Options Floor Lighting
O-1-0	Opt. Sunroom - Elevs-Floors-Elecs
O-2-0	Opt. Covered Patio - Elevs-Floors-Lights
OA-1-0	Opt. 3rd Car Garage - Elevs-Floors-Lights
OA-2-0	Opt. Flush Porch - Elevs-Floors-Lights
OA-3-0	Opt. 3rdCarGarage-SideLoad-Elevs-Firs-Lights
OB-1-0	Exterior Elevations - Coastal
OB-2-0	Exterior Elevations - Coastal
OB-3-0	Wall Section Details
OB-4-0	First Floor Plan & Options
OB-5-0	Second Floor Plan & Options
OB-6-0	Attic Floor Plan & Options
OB-7-0	First & Second Floor Lighting Plans
OB-8-0	Attic Floor & Optional Lighting Plans
OB-9-0	Opt. 3rd Car Garage - Elevs-Floors-Lights
OB-10-0	Opt. Flush Porch - Elevs-Floors-Lights
OB-11-0	Opt. 3rdCarGarage-SideLoad-Elevs-Firs-Lights
OD-1-0	Exterior Elevations - Craftsman
OD-2-0	Exterior Elevations - Craftsman
OD-3-0	Wall Section Details
OD-4-0	First Floor Plan & Options
OD-5-0	Second Floor Plan & Options
OD-6-0	Attic Floor Plan & Options
OD-7-0	First & Second Floor Lighting Plans
OD-8-0	Attic Floor & Optional Lighting Plans
OD-9-0	Opt. 3rd Car Garage - Elevs-Floors-Lights
OD-10-0	Opt. Flush Porch - Elevs-Floors-Lights
OD-11-0	Opt. 3rdCarGarage-SideLoad-Elevs-Firs-Lights
OD-12-0	Opt. Wrapped Porch - Elevs-Firs-Lights
OE-1-0	Exterior Elevations - Euro
OE-2-0	Exterior Elevations - Euro
OE-3-0	Wall Section Details
OE-4-0	First Floor Plan & Options
OE-5-0	Second Floor Plan & Options
OE-6-0	Attic Floor Plan & Options
OE-7-0	First & Second Floor Lighting Plans
OE-8-0	Attic Floor & Optional Lighting Plans
OE-9-0	Opt. 3rd Car Garage - Elevs-Floors-Lights
OE-10-0	Opt. Flush Porch - Elevs-Floors-Lights
OE-11-0	Opt. 3rdCarGarage-SideLoad-Elevs-Firs-Lights
AD-1	Standard Details
AD-2	Standard Details
Structural Plans	
Sheet	See Structural Plans (Done by Others)



Scales UNO:
 22X34: 1/4"=1'-0"
 11X17: 1/8"=1'-0"

McKee Homes, LLC
 Brooks II - Base - Classic
 Base Plan - Elev. A (RHG)
 Architectural Set - Master Plan (4-23-19)

PROGRESS DATE: --
 ISSUE DATE: 04/06/15
 DRAWN BY: A.S.H./B.B.
 CHECKED BY: A.S.H./B.B.

REVISIONS:

DATE	BY	DESCRPT.
8-21-17	BB	Master Plan Set - Archs
5-25-18	BB	Master Plan Set - Archs
2-4-19	BB	2018 Codes - Plan mods
4-23-19	BB	Full Plans for Opt. Plan Types

COVER SHEET

SHEET NO. CS-1-0
 PLAN NO. 000112

GENERAL NOTES: 1. THESE PLANS ARE TO BE COORDINATED WITH ALL SITE INFORMATION BY OWNER AND CONTRACTOR. 2. CONTRACTOR IS TO VERIFY ALL INFORMATION OF CONDITIONS OR ITEMS VARYING FROM DEPICTED INFORMATION. 3. THESE WORKS ARE RESPONSIBLE FOR CONSTRUCTION VARIATIONS FROM THE INFORMATION SHOWN. 4. MCKEE HOMES WILL ASSUME ANY AND ALL LIABILITY FOR EXPENSES ASSOCIATED WITH ERRORS AND OMISSIONS ON THESE DRAWINGS HEREIN. 5. THESE PLANS ARE UNSEALED FOR EXISTING INFORMATION. BY SEALING THESE PLANS, THE COSTS ASSOCIATED WITH THESE PLANS.



FRONT ELEVATION - EURO
 22x34 PRINTS SCALE: 1/4"=1'-0"
 11x17 PRINTS SCALE: 1/8"=1'-0"

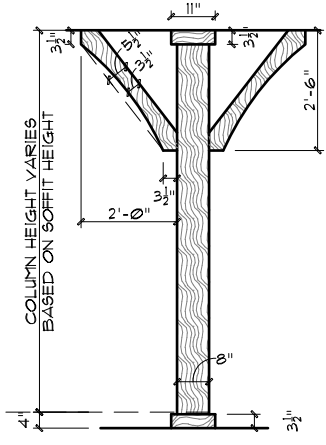

Column Detail
 Euro Elevation

GENERAL NOTES
 * USE ICE AND WATER SHIELD AT ALL ROOF PLANES SLOPED BELOW 4:12.
 SEE FLOOR PLANS, ROOF PLAN AND/OR ROOF FRAMING DETAIL SHEET FOR PLATE HEIGHTS AT RAFTER AND/OR TRUSS BEARING LOCATIONS.
 SEE ROOF PLANS FOR ATTIC VENTILATION CALCULATIONS.
 SEE SHEET D-2 FOR FLASHING DETAILS AND REQUIRED LOCATIONS.

REQUIRED FLASHING LOCATIONS
 1) ALL MATERIAL CHANGE INTERSECTIONS.
 2) ALL WINDOW / DOOR OPENINGS.
 3) ALL ROOF VALLEYS.
 BUILDER TO VERIFY ON SITE FLASHING IS INSTALLED TO MEET CODE REQUIREMENTS.

ARCHITECTURAL PLANS EXTERIOR MATERIALS

- SHINGLE ROOF PER BUILDER
- HORIZONTAL SIDING PER BUILDER
- SHAKE SIDING PER BUILDER
- BOARD-N-BATTEN PER BUILDER
- STONE PER BUILDER
- STUCCO PER BUILDER
- SCREEN PER BUILDER
- BRICK ROWLOCK/SOLDIER PER BUILDER
- STONE ROWLOCK/SOLDIER PER BUILDER

NOTE: THIS PLAN IS A REPRESENTATION ONLY. IT IS NOT TO BE USED FOR CONSTRUCTION. THE BUILDER SHALL VERIFY ALL INFORMATION ON THESE PLANS AND MAKE ANY NECESSARY CHANGES TO THE PLANS BEFORE CONSTRUCTION. THE BUILDER SHALL BE RESPONSIBLE FOR OBTAINING ALL NECESSARY PERMITS AND APPROVALS. THE BUILDER SHALL BE RESPONSIBLE FOR VERIFYING ALL INFORMATION ON THESE PLANS AND MAKE ANY NECESSARY CHANGES TO THE PLANS BEFORE CONSTRUCTION. THE BUILDER SHALL BE RESPONSIBLE FOR OBTAINING ALL NECESSARY PERMITS AND APPROVALS. THE BUILDER SHALL BE RESPONSIBLE FOR VERIFYING ALL INFORMATION ON THESE PLANS AND MAKE ANY NECESSARY CHANGES TO THE PLANS BEFORE CONSTRUCTION.

DOOR AND WINDOW MULLION STYLES TO MATCH FRONT ELEVATIONS - PER BUILDER

DELUXE SUNROOM SEE PG. O-1-0

1) PLANS HAVE BEEN ISSUED TO MCKEE HOMES LLC. AS A BASE PLAN MASTER SET.
 2) PLANS AND OPTIONS ARE DESIGNED FOR SINGLE USE ONLY AND NOT IN COMBINATION WITH EACH OTHER. THE USE OF MULTIPLE OPTIONS TOGETHER MAY CAUSE ADDITIONAL CHANGES TO ORIGINAL STRUCTURE AND ARCHITECTURAL DESIGNS.
 3. ANY ON SITE CHANGES OR VARIATIONS FROM PLANS SHOULD MUST BE VERIFIED WITH DESIGNER OR ENGINEER TO MEET LOCAL CODES, GUIDELINES, LOAD CALCULATIONS ETC.



LEFT ELEVATION
 22x34 PRINTS SCALE: 1/4"=1'-0"
 11x17 PRINTS SCALE: 1/8"=1'-0"



Scales UNO:
 22X34: 1/4"=1'-0"
 11X17: 1/8"=1'-0"

McKee Homes, LLC
 Brooks II - Option - Euro
 Base Plan - Elev. E (RHG)
 Architectural Set - Master Plan (4-23-19)

PROGRESS DATE:	--	
ISSUE DATE:	04/06/15	
DRAWN BY:	A.S.H./B.B.	
CHECKED BY:	A.S.H./B.B.	
REVISIONS		
DATE	BY	DESCRPT.
8-21-17	BB	Master Plan Set - Archs
5-25-18	BB	Master Plan Set - Archs
2-4-19	BB	2018 Codes - Plan mods
4-23-19	BB	Full Plans for Opt. Plan Types

Exterior Elevations
 SHEET NO. **OE-1-0**
 PLAN NO. **000112**

GENERAL NOTES: 1. THESE PLANS SHALL BE CONSIDERED AS A REPRESENTATION ONLY. THE BUILDER SHALL VERIFY ALL INFORMATION ON THESE PLANS AND MAKE ANY NECESSARY CHANGES TO THE PLANS BEFORE CONSTRUCTION. THE BUILDER SHALL BE RESPONSIBLE FOR OBTAINING ALL NECESSARY PERMITS AND APPROVALS. THE BUILDER SHALL BE RESPONSIBLE FOR VERIFYING ALL INFORMATION ON THESE PLANS AND MAKE ANY NECESSARY CHANGES TO THE PLANS BEFORE CONSTRUCTION. THE BUILDER SHALL BE RESPONSIBLE FOR OBTAINING ALL NECESSARY PERMITS AND APPROVALS. THE BUILDER SHALL BE RESPONSIBLE FOR VERIFYING ALL INFORMATION ON THESE PLANS AND MAKE ANY NECESSARY CHANGES TO THE PLANS BEFORE CONSTRUCTION.

PROGRESS DATE:	--
ISSUE DATE:	04/06/15
DRAWN BY:	ASH/BB
CHECKED BY:	ASH/BB
DATE:	BT
DESCRPT:	
8-21-17	BB Master Plan Set - Archs
5-25-18	BB Master Plan Set - Archs
2-4-19	BB 2018 Codes - Plan mods
4-23-19	BB Full Elev. for Opt. Plan mods

Wall Section Details
SHEET NO. OE-3-0
PLAN NO. 000112

GENERAL NOTES
* USE ICE AND WATER SHIELD AT ALL ROOF PLANES SLOPED BELOW 4:12.
SEE FLOOR PLANS, ROOF PLAN, AND/OR ROOF FRAMING DETAIL SHEET FOR PLATE HEIGHTS AT RAFTER AND/OR TRUSS BEARING LOCATIONS.
SEE ROOF PLANS FOR ATTIC VENTILATION CALCULATIONS.
SEE SHEET D-2 FOR FLASHING DETAILS AND REQUIRED LOCATIONS.

REQUIRED FLASHING LOCATIONS
1) ALL MATERIAL CHANGE INTERSECTIONS.
2) ALL WINDOW / DOOR OPENINGS.
3) ALL ROOF VALLEYS.
BUILDER TO VERIFY ON SITE FLASHING IS INSTALLED TO MEET CODE REQUIREMENTS.

**NOTE: DETAILS PROVIDED ARE FOR PLATE DETAILS ONLY. REFER TO STRUCTURAL SHEETS & TRUSS LAYOUT PLANS TO CONFIRM FLOOR MEMBER SIZE & DIRECTIONS, RAFTER / TRUSS SIZES & DIRECTIONS, AND ROOF OVERHANGS.

1) PLANS HAVE BEEN ISSUED TO MCKEE HOMES LLC, AS A BASE PLAN MASTER SET.
2) PLANS AND OPTIONS ARE DESIGNED FOR SINGLE USE ONLY AND NOT IN COMBINATION WITH EACH OTHER. THE USE OF MULTIPLE OPTIONS TOGETHER MAY CAUSE ADDITIONAL CHANGES TO ORIGINAL STRUCTURE AND ARCHITECTURAL DESIGNS.
3. ANY ON SITE CHANGES OR VARIATIONS FROM PLANS SHOWN MUST BE VERIFIED WITH DESIGNER OR ENGINEER TO MEET LOCAL CODES, GUIDELINES, LOAD CALCULATIONS ETC.

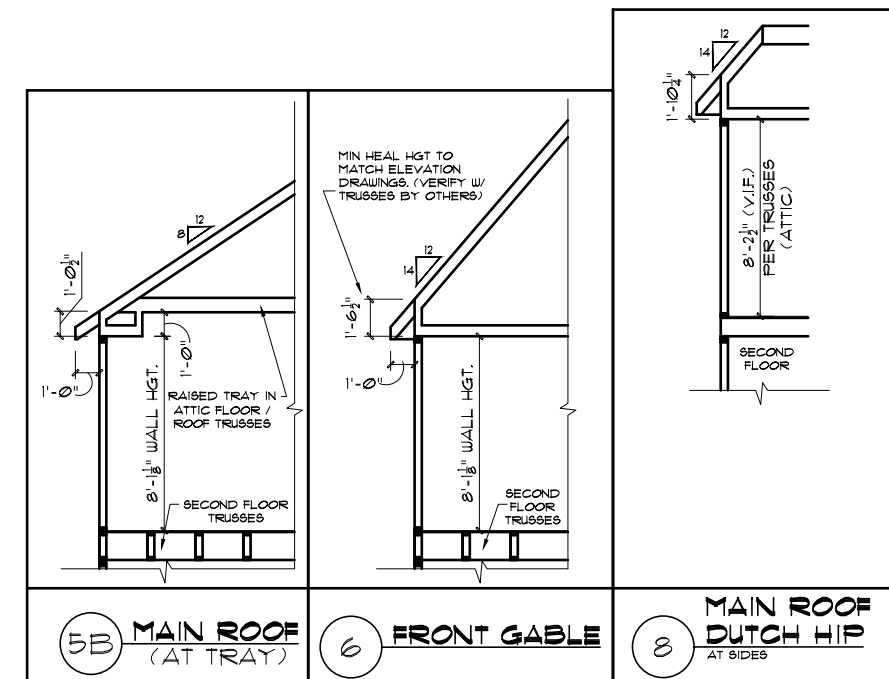
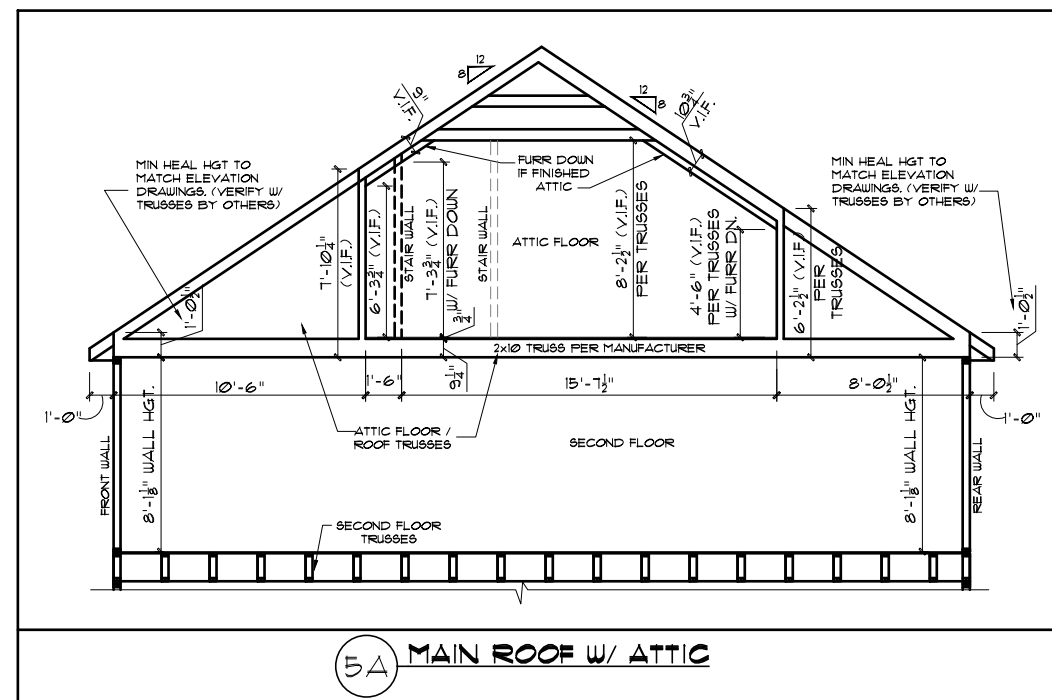
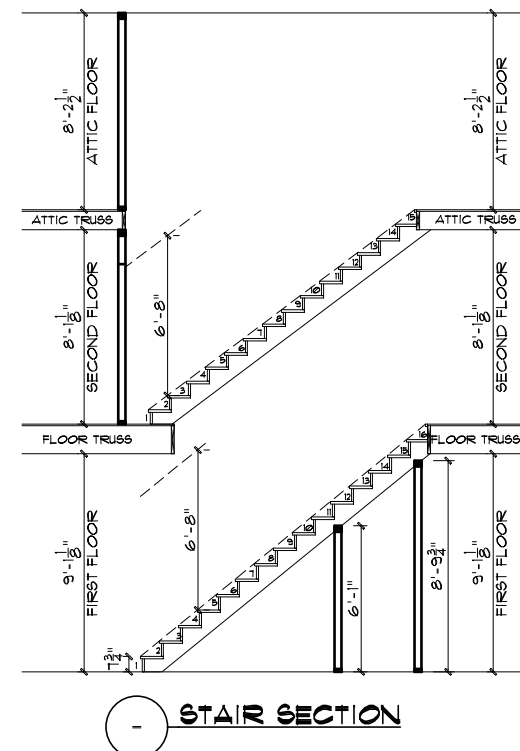
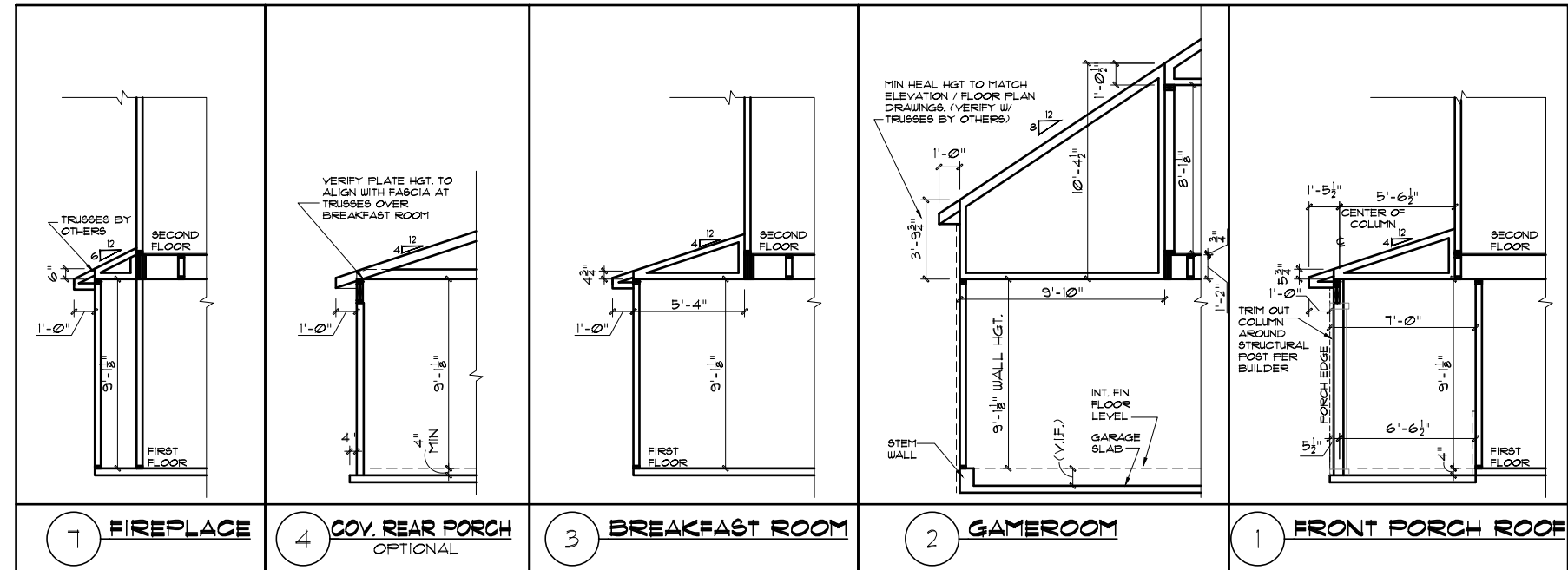

4. MCKEE HOMES WILL ASSUME ANY AND ALL LIABILITY FOR ERRORS ASSOCIATED WITH ERRORS AND OMISSIONS ON THESE DRAWINGS HEREIN.
5. THESE NOTES IS RESPONSIBLE FOR EXISTING, UNLAWFUL, OR UNLAWFUL CONSTRUCTION COSTS ASSOCIATED WITH THESE PLANS.

GENERAL NOTES:
1. THESE PLANS ARE TO BE COORDINATED WITH ALL PERMITS REQUIRED BY OWNER AND CONTRACTOR, AND ALL LOCAL CODES.
2. CONTRACTOR IS TO VERIFY ALL MATERIALS, METHODS OF CONSTRUCTION OR OTHER VARIATIONS FROM DESIGNED INFORMATION.
3. MCKEE HOMES IS RESPONSIBLE FOR CONTRIBUTED VARIATIONS FROM THE INFORMATION EXPECTED.

COPYRIGHT © 2015 BY MCKEE HOMES, LLC. ALL RIGHTS RESERVED.
REPRODUCTION OF THIS SHEET, IN WHOLE OR IN PART, IS STRICTLY PROHIBITED.
SEE STRUCTURAL PLANS FOR APPROPRIATE PROFESSIONAL SEALS.

NOTE: THIS PLAN ELEVATION PRODUCED BY GMD DESIGN GROUP, IS DERIVATIVE WORKS OF "THE BROOKS II" BY PLANWORK FOR MCKEE HOMES WITH WRITTEN PERMISSION OBTAINED BY THE BUILDER/OWNER FOR REPRODUCTION WITH MODIFICATION IN THE PURCHASE LETTER DATED, JANUARY 20th, 2014. ADDRESSED TO PAT MCKEE AT MCKEE HOMES, THE BUILDER/OWNER IS TO REVIEW AND APPROVE PLANS COORDINATION PRIOR TO CONSTRUCTION BEGINNING.

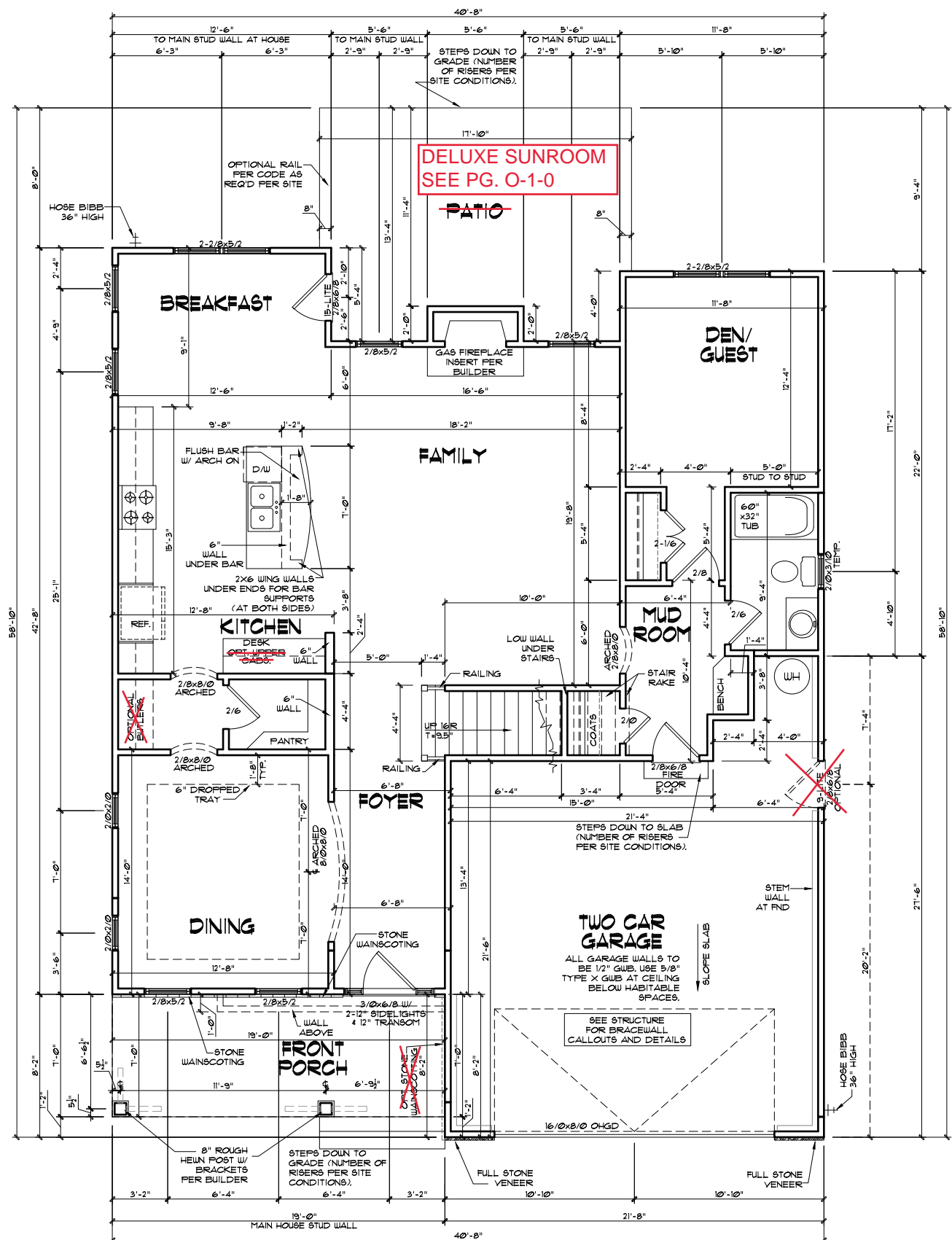

FIRST FLOOR PLAN - EURO

22x34 PRINTS SCALE: 1/4"=1'-0"
 11x17 PRINTS SCALE: 1/8"=1'-0"

EXTERIOR DOORS/WINDOWS (DP RATING)

- ALL EXTERIOR DOORS TO BE DP41 WHEN BUILT IN HIGH WIND ZONE.
- ALL EXTERIOR WINDOWS TO BE DP50 WHEN BUILT IN HIGH WIND ZONE.

1) PLANS HAVE BEEN ISSUED TO MCKEE HOMES LLC, AS A BASE PLAN MASTER SET.

2) PLANS AND OPTIONS ARE DESIGNED FOR SINGLE USE ONLY AND NOT IN COMBINATION WITH EACH OTHER. THE USE OF MULTIPLE OPTIONS TOGETHER MAY CAUSE ADDITIONAL CHANGES TO ORIGINAL STRUCTURE AND ARCHITECTURAL DESIGNS.

3. ANY ON SITE CHANGES OR VARIATIONS FROM PLANS SHOULD MUST BE VERIFIED WITH DESIGNER OR ENGINEER TO MEET LOCAL CODES, GUIDELINES, LOAD CALCULATIONS ETC.

WINDOW FALL PREVENTION PROTECTION

IF ANY PART OF THE CLEAR OPENING OF THE OPERABLE PORTION OF A WINDOW IS LOCATED MORE THAN 72" ABOVE THE EXTERIOR GRADE THEN THE LOWEST PART OF THE CLEAR OPENING MUST BE AT LEAST 24" ABOVE THE FLOOR OF THE ROOM IN WHICH IT IS LOCATED.

EXCEPTIONS:

1. THE WINDOW IS A FIXED UNIT
2. THE OPENING DOES NOT ALLOW THE PASSAGE OF A 4- INCH DIAMETER SPHERE.
3. THE WINDOW IS EQUIPPED WITH A WINDOW FALL PREVENTION DEVICE MEETING ASTM F2090.
4. THE WINDOW IS EQUIPPED WITH AN APPROVED WINDOW OPENING LIMITING DEVICE.

NOTE: WHEN USED WITH AN EMERGENCY ESCAPE AND RESCUE WINDOW, OPENING LIMITING DEVICES AND FALL PREVENTION DEVICES MUST BE APPROVED FOR EMERGENCY ESCAPE AND RESCUE PROVISIONS.

BROOKS II - EURO

Heated Square Footage	
First Floor	1,329
Second Floor	1,618
Total *	2,947
Unheated Square Footage	
Covered Porch - Front	133
Garage (Front Load)	491
Garage (Side Load Opt)	491
Patio - Rear	221
Walk-Up Attic (Unf. Mech)	115
Walk-up Attic (5/0 Clg.) (Opt. Finished or Unfin.)	530

IF ATTIC STAIR DOOR IS AT TOP ADD ADDITIONAL 34 HTD. SQUARE FEET

GENERAL NOTES

WALL THICKNESS / ANGLES
 ALL EXTERIOR STUD WALLS ARE DRAWN 4" THICK UNO.
 ALL INTERIOR STUD WALLS ARE DRAWN 4" THICK UNO.
 ANGLED WALLS ARE DRAWN @ 45° UNO.

EGRESS
 ALL BEDROOMS MUST HAVE AT LEAST ONE WINDOW WHICH CONFORMS TO EGRESS REQUIREMENTS FOR CLEAR OPENING HEIGHT AND WIDTH. IT IS THE CONTRACTOR'S RESPONSIBILITY TO VERIFY EGRESS SIZING PER CODE BASED ON CHOSEN MANUFACTURER, AS PRODUCT SIZES MAY VARY.

WALL/CEILING HEIGHTS
 WALL AND CEILING HEIGHTS NOTES ARE BASED ON NOMINAL WALL SIZE (I.E. A 9'-1 1/8" ACTUAL WALL HEIGHT IS LABELED 9/0 ON THE PLANS).

ALL VAULTED OR SLOPED CEILING ARE TO BE FURRED DOWN TO ACCOMMODATE REQUIRED CEILING INSULATION AND 1" AIRSPACE. VERIFY CODES FOR INFORMATION ON INSULATION REQUIREMENTS.

STAIRS
 STAIR TREADS ARE MEASURED FROM NOSING TO NOSING (N/N).
 MAXIMUM STAIR RISE HEIGHT TO BE NO GREATER THAN 8-1/4"

ARCHITECTURAL PLANS WALL LEGEND

- STANDARD STUD WALL INT OR EXT IF EXT SEE ELEVATIONS FOR SIDING STYLE THICKNESS OF WALL NOTED IN PLAN NOTES OR AT WALL LOCATIONS
- STANDARD STUD WALL WITH 5" BRICK VENEER FOUNDATION WALL LEDGE STUD THICKNESS AS NOTED IN PLAN NOTES OR AT WALL LOCATIONS
- STANDARD STUD WALL WITH STACKED STONE VENEER STUD THICKNESS AS NOTED IN PLAN NOTES OR AT WALL LOCATIONS (NOTE BUILDER TO VERIFY STONE THICKNESS 4 NOTIFY PLAN DESIGNER IF THICKNESS IS MORE THAN 5" BEFORE FOOTINGS ARE POURED)
- STANDARD STUD WALL WITH APPLIED STONE VENEER STUD THICKNESS AS NOTED IN PLAN NOTES OR AT WALL LOCATIONS (NOTE: NO FOUNDATION SUPPORT IS REPRESENTED ON STRUCTURAL PLANS) IF STACKED STONE IS TO BE USED BUILDER MUST NOTIFY PLAN DESIGNER BEFORE FOOTINGS ARE POURED
- STANDARD STUD WALL WITH LOW APPLIED STONE WAINSCOTING SEE ELEVATIONS FOR HEIGHT & FINISH MATERIAL AT EXT STUD WALL ABOVE. STUD THICKNESS AS NOTED IN PLAN NOTES OR AT WALL LOCATIONS
- STANDARD STUD WALL WITH 5" FOUNDATION LEDGE FOR LOW BRICK OR STACKED STONE WAINSCOTING. SEE ELEVATIONS FOR HEIGHT & FINISH MATERIAL AT EXT STUD WALL ABOVE. STUD THICKNESS AS NOTED IN PLAN NOTES OR AT WALL LOCATIONS
- HALF WALL WITH 1x CAP (42" HEIGHT UNLESS NOTED OTHERWISE ON PLANS)



Scales UNO:
 22X34: 1/4"=1'-0"
 11X17: 1/8"=1'-0"

Mckee Homes, LLC
 Brooks II - Option - Euro
 Base Plan - Elev. E (RHG)
 Architectural Set - Master Plan (4-23-19)

PROGRESS DATE: --

ISSUE DATE: 04/06/15

DRAWN BY: A.S.H./B.B.

CHECKED BY: A.S.H./B.B.

REVISIONS

DATE	BY	DESCRPT.
8-21-17	BB	Master Plan Set - Archs
5-25-18	BB	Master Plan Set - Archs
2-4-19	BB	2018 Codes - Plan mods
4-23-19	BB	Full Plans for Opt. Plan Types

First Floor Plan and Options

SHEET NO. **OE-4-0**

PLAN NO. **000112**

GENERAL NOTES:
 1. THESE SHEETS SHALL ASSUME ANY AND ALL LIABILITY FOR EXPENSES ASSOCIATED WITH EGRESS AND OPENINGS ON THESE DRAWINGS HEREIN.
 2. CONTRACTOR IS TO VERIFY ALL EGRESS REQUIREMENTS PER CODES.
 3. CONTRACTOR IS TO VERIFY ALL ARCHITECTURAL PRESENTATION OF CONDITIONS OR ITEMS VARYING FROM DESIGNED INFORMATION.
 4. MCKEE HOMES WILL ASSUME ANY AND ALL LIABILITY FOR EXPENSES ASSOCIATED WITH EGRESS AND OPENINGS ON THESE DRAWINGS HEREIN.
 5. THESE SHEETS ARE FOR EGRESS AND OPENINGS INFORMATION ONLY. CONTRACTOR SHALL VERIFY ALL EGRESS AND OPENING REQUIREMENTS PER CODES.

NOTE: THIS PLAN ELEVATION PRODUCED BY GMD DESIGN GROUP IS DERIVATIVE WORKS OF THE BROOKS II BY PLANWORK FOR MCKEE HOMES WITH WRITTEN PERMISSION OBTAINED BY THE BUILDER/OWNER FOR REPRODUCTION WITH MODIFICATION IN THE PURCHASE LETTER DATED, JANUARY 20th, 2014. ADDRESSED TO PAT MCKEE AT MCKEE HOMES. THE BUILDER/OWNER IS TO REVIEW AND APPROVE PLANS COORDINATION PRIOR TO CONSTRUCTION BEGINNING.



Scales UNO:
22X34: 1/4"=1'-0"
11X17: 1/8"=1'-0"

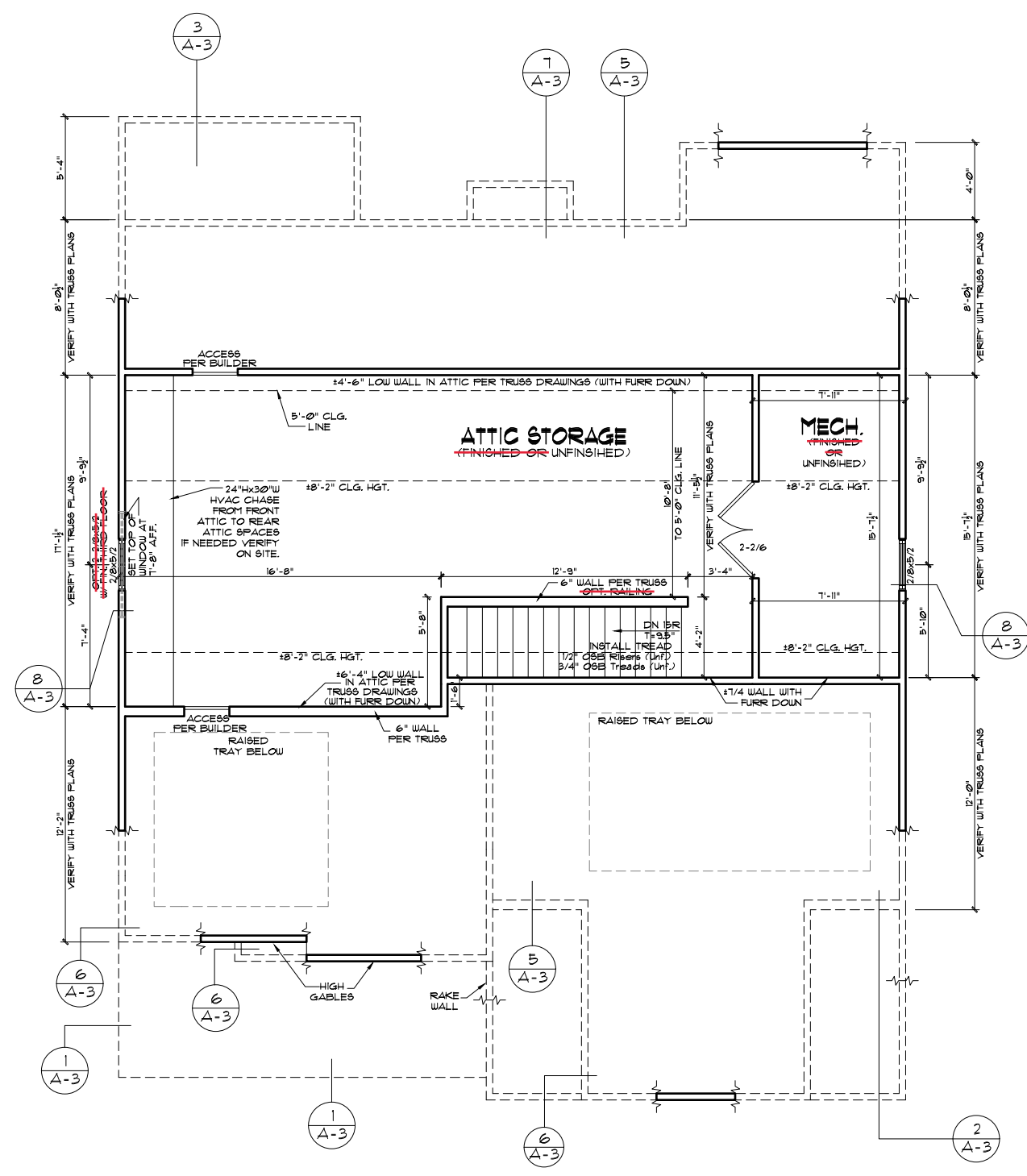

ATTIC NOTES

1. KNEEWALLS IN UNFINISHED ATTIC ARE OPTIONAL UNLESS USED TO SUPPORT RAFTERS (SEE STRUCTURAL SHEETS). KNEEWALL LOCATION/HEIGHT MAY BE ADJUSTED IN THE FIELD IF THESE WALLS ARE NOT LOAD BEARING.
2. CEILING LINES SHOWN IN UNFINISHED ATTIC MAY BE JUST FOR REPRESENTATION OF FUTURE FLAT CEILING. IF A FLAT CEILING IS DESIRED, THIS WILL HAVE TO BE COORDINATED WITH THE STRUCTURAL PLANS.

GENERAL NOTES

WALL THICKNESS / ANGLES
ALL EXTERIOR STUD WALLS ARE DRAWN 4" THICK UNO. ALL INTERIOR STUD WALLS ARE DRAWN 4" THICK UNO. ANGLED WALLS ARE DRAWN @ 45° UNO.

EGRESS
ALL BEDROOMS MUST HAVE AT LEAST ONE WINDOW WHICH CONFORMS TO EGRESS REQUIREMENTS FOR CLEAR OPENING HEIGHT AND WIDTH. IT IS THE CONTRACTOR'S RESPONSIBILITY TO VERIFY EGRESS SIZING PER CODE BASED ON CHOSEN MANUFACTURER, AS PRODUCT SIZES MAY VARY.

WALL/CEILING HEIGHTS
WALL AND CEILING HEIGHTS NOTES ARE BASED ON NOMINAL WALL SIZE (IE. A 9'-1 1/8" ACTUAL WALL HEIGHT IS LABELED 9'0" ON THE PLANS).

ALL VAULTED OR SLOPED CEILING ARE TO BE FURRED DOWN TO ACCOMMODATE REQUIRED CEILING INSULATION AND 1" AIRSPACE. VERIFY CODES FOR INFORMATION ON INSULATION REQUIREMENTS.

STAIRS
STAIR TREADS ARE MEASURED FROM NOSING TO NOSING (N/N). MAXIMUM STAIR RISE HEIGHT TO BE NO GREATER THAN 8-1/4"

ARCHITECTURAL PLANS WALL LEGEND

- STANDARD STUD WALL INT OR EXT IF EXT SEE ELEVATIONS FOR SIDING STYLE THICKNESS OF WALL NOTED IN PLAN NOTES OR AT WALL LOCATIONS
- STANDARD STUD WALL WITH 5" BRICK VENEER FOUNDATION WALL LEDGE STUD THICKNESS AS NOTED IN PLAN NOTES OR AT WALL LOCATIONS
- STANDARD STUD WALL WITH STACKED STONE VENEER STUD THICKNESS AS NOTED IN PLAN NOTES OR AT WALL LOCATIONS (NOTE: BUILDER TO VERIFY STONE THICKNESS & NOTIFY PLAN DESIGNER IF THICKNESS IS MORE THAN 5" BEFORE FOOTINGS ARE POURED)
- STANDARD STUD WALL WITH APPLIED STONE VENEER STUD THICKNESS AS NOTED IN PLAN NOTES OR AT WALL LOCATIONS (NOTE: NO FOUNDATION SUPPORT IS REPRESENTED ON STRUCTURAL PLANS) IF STACKED STONE IS TO BE USED BUILDER MUST NOTIFY PLAN DESIGNER BEFORE FOOTINGS ARE POURED
- STANDARD STUD WALL WITH LOW APPLIED STONE WAINSCOTING SEE ELEVATIONS FOR HEIGHT & FINISH MATERIAL AT EXT STUD WALL ABOVE. STUD THICKNESS AS NOTED IN PLAN NOTES OR AT WALL LOCATIONS
- STANDARD STUD WALL WITH 5" FOUNDATION LEDGE FOR LOW BRICK OR STACKED STONE WAINSCOTING. SEE ELEVATIONS FOR HEIGHT & FINISH MATERIAL AT EXT STUD WALL ABOVE. STUD THICKNESS AS NOTED IN PLAN NOTES OR AT WALL LOCATIONS
- HALF WALL WITH 1x CAP (42" HEIGHT UNLESS NOTED OTHERWISE ON PLANS)

1) PLANS HAVE BEEN ISSUED TO MCKEE HOMES LLC, AS A BASE PLAN MASTER SET.

2) PLANS AND OPTIONS ARE DESIGNED FOR SINGLE USE ONLY AND NOT IN COMBINATION WITH EACH OTHER. THE USE OF MULTIPLE OPTIONS TOGETHER MAY CAUSE ADDITIONAL CHANGES TO ORIGINAL STRUCTURE AND ARCHITECTURAL DESIGNS.

3. ANY ON SITE CHANGES OR VARIATIONS FROM PLANS SHOWN MUST BE VERIFIED WITH DESIGNER OR ENGINEER TO MEET LOCAL CODES, GUIDELINES, LOAD CALCULATIONS ETC.

EXTERIOR DOORS/WINDOWS (DP RATING)

- ALL EXTERIOR DOORS TO BE DP41 WHEN BUILT IN HIGH WIND ZONE.
- ALL EXTERIOR WINDOWS TO BE DP50 WHEN BUILT IN HIGH WIND ZONE.

WINDOW FALL PREVENTION PROTECTION

IF ANY PART OF THE CLEAR OPENING OF THE OPERABLE PORTION OF A WINDOW IS LOCATED MORE THAN 12" ABOVE THE EXTERIOR GRADE THEN THE LOWEST PART OF THE CLEAR OPENING MUST BE AT LEAST 24" ABOVE THE FLOOR OF THE ROOM IN WHICH IT IS LOCATED.

EXCEPTIONS:

1. THE WINDOW IS A FIXED UNIT
2. THE OPENING DOES NOT ALLOW THE PASSAGE OF A 4- INCH DIAMETER SPHERE.
3. THE WINDOW IS EQUIPPED WITH A WINDOW FALL PREVENTION DEVICE MEETING ASTM F2090.
4. THE WINDOW IS EQUIPPED WITH AN APPROVED WINDOW OPENING LIMITING DEVICE.

NOTE: WHEN USED WITH AN EMERGENCY ESCAPE AND RESCUE WINDOW, OPENING LIMITING DEVICES AND FALL PREVENTION DEVICES MUST BE APPROVED FOR EMERGENCY ESCAPE AND RESCUE PROVISIONS.

ATTIC FLOOR PLAN - EURO
22x34 PRINTS SCALE: 1/4"=1'-0"
11x17 PRINTS SCALE: 1/8"=1'-0"

GENERAL NOTES: 1. THESE HEIGHTS ARE BASED ON ALL USE INFORMATION BY OWNER AND CONTRACTOR. 2. CONTRACTOR IS TO VERIFY ARCHITECT PRESENTS OF CONDITIONS OR ITEMS VARYING FROM SPECIFIED INFORMATION. 3. USER NOTES IS RESPONSIBLE FOR CONTRIBUTED VARIATIONS FROM THE INFORMATION PROVIDED.

4. THESE HEIGHTS ARE BASED ON ALL USE INFORMATION BY OWNER AND CONTRACTOR. 5. THESE HEIGHTS ARE BASED ON ALL USE INFORMATION BY OWNER AND CONTRACTOR. 6. THESE HEIGHTS ARE BASED ON ALL USE INFORMATION BY OWNER AND CONTRACTOR.

McKee Homes, LLC
Brooks II - Option - Euro
Base Plan - Elev. E (RHG)
Architectural Set - Master Plan (4-23-19)

PROGRESS DATE:	--
ISSUE DATE:	04/06/15
DRAWN BY:	A.S.H./B.B.
CHECKED BY:	A.S.H./B.B.
REVISIONS	
DATE:	BY:
8-21-17	BB
8-25-18	BB
2-4-19	BB
4-23-19	BB

Attic Floor Plan and Options
SHEET NO. OE-6-0
PLAN NO. 000112

UPGRADED LIGHTING PACKAGE
 1. ALL CEILING MOUNTS TO BE REPLACED WITH RECESSED CAN LIGHTS IN MAIN LIVING AREAS INCLUDING:
 - FAMILY
 - KITCHEN
 - HALLWAYS

ELECTRICAL NOTES
 - ONLY ONE PHONE LINE IS INCLUDED IN BASE HOUSE
 - ALL OTHER PHONE LINES ARE OPTIONAL
 - 2 OUTLETS INCLUDED IN KITCHEN FOR FUTURE UNDER CABINET LIGHTING
 - UNDER-CABINET LIGHTING IS OPTIONAL
 - RECEPTACLES ARE TO BE INSTALLED AS STANDARD PER LATEST CODE REQUIREMENTS

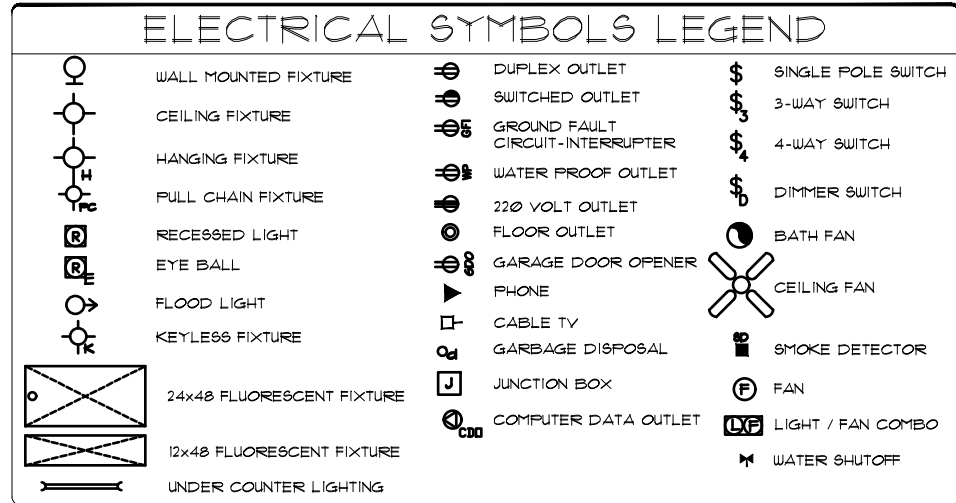

NOTE: THIS PLAN ELEVATION PRODUCED BY GMD DESIGN GROUP, IS DERIVATIVE WORKS OF THE BROOKS II BY PLANWORK FOR MCKEE HOMES WITH WRITTEN PERMISSION OBTAINED BY THE BUILDER/OWNER FOR REPRODUCTION WITH MODIFICATION IN THE PURCHASE LETTER DATED, "JANUARY 20th, 2014," ADDRESSED TO PAT MCKEE AT MCKEE HOMES. THE BUILDER/OWNER IS TO REVIEW AND APPROVE PLANS COORDINATION PRIOR TO CONSTRUCTION BEGINNING.



Scales UNO:
 22X34: 1/4"=1'-0"
 11X17: 1/8"=1'-0"

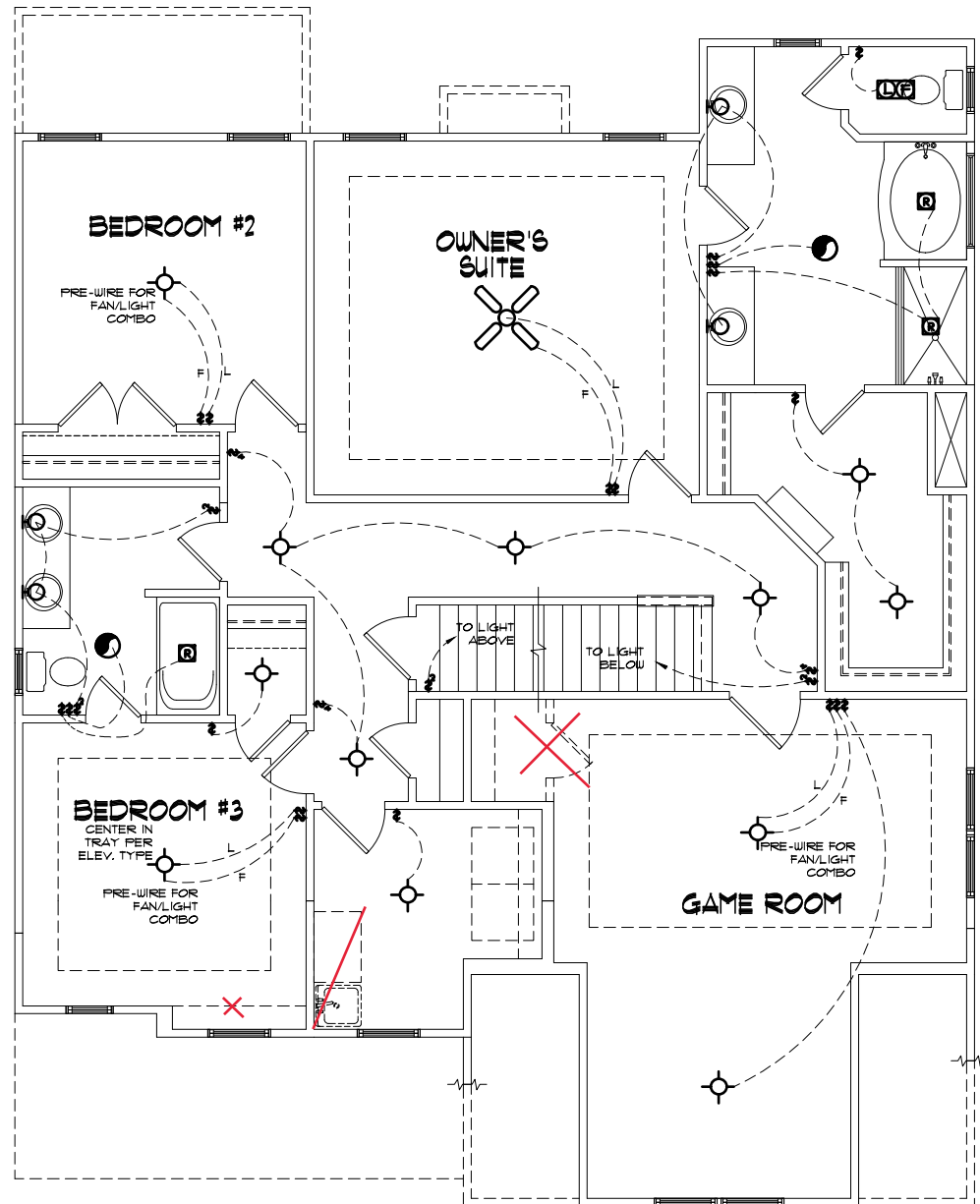

ELECTRICAL NOTES
 1. ELECTRICAL CONTRACTOR MUST CONFIRM ELECTRICAL LAYOUT WITH BUILDER AND/OR HOMEOWNER. BUILDER/HOMEOWNER SPECIFICATIONS WILL OVERRIDE THESE DOCUMENTS.
 2. VERIFY LOCATION OF 240V. RECEPTACLES, AS GAS APPLIANCES MAY BE SUBSTITUTED FOR ELECTRICAL IN SOME CASES.

- ELECTRICAL:**
- 1) ALL ELECTRICAL DESIGN AND INSTALLATION IS TO CONFORM TO THE NATIONAL ELECTRICAL CODE LATEST EDITION. ALL EQUIPMENT SHALL BE UL LABELED.
 - 2) ALL SWITCHES TO BE MOUNTED 3'-10" ABOVE FINISHED FLOOR UNLESS OTHERWISE NOTED.
 - 3) INSTALL CONVENIENCE OUTLETS AT 18" ABOVE FINISHED FLOOR. MAXIMUM SPACING 12'-0" O.C. INSTALL AT ALL WALLS OF 24" OR GREATER WIDTH.
 - 4) UL SMOKE DETECTORS SHALL BE LOCATED IN ALL BEDROOMS, AND ONE EACH ADDITIONALLY AT EACH LEVEL. OTHER LOCATIONS SHOWN ON DRAWINGS. HARDWIRE ALL DETECTORS TOGETHER AND PROVIDE BATTERY BACK-UP.
 - 5) INSTALL GROUND FAULT RECEPTACLES IN BATHROOMS, KITCHENS, AND OTHER WET LOCATIONS AS REQUIRED BY N.E.C. 210-8.

- 1) PLANS HAVE BEEN ISSUED TO MCKEE HOMES LLC, AS A BASE PLAN MASTER SET.
- 2) PLANS AND OPTIONS ARE DESIGNED FOR SINGLE USE ONLY AND NOT IN COMBINATION WITH EACH OTHER. THE USE OF MULTIPLE OPTIONS TOGETHER MAY CAUSE ADDITIONAL CHANGES TO ORIGINAL STRUCTURE AND ARCHITECTURAL DESIGNS.
3. ANY ON SITE CHANGES OR VARIATIONS FROM PLANS SHOWN MUST BE VERIFIED WITH DESIGNER OR ENGINEER TO MEET LOCAL CODES, GUIDELINES, LOAD CALCULATIONS ETC.

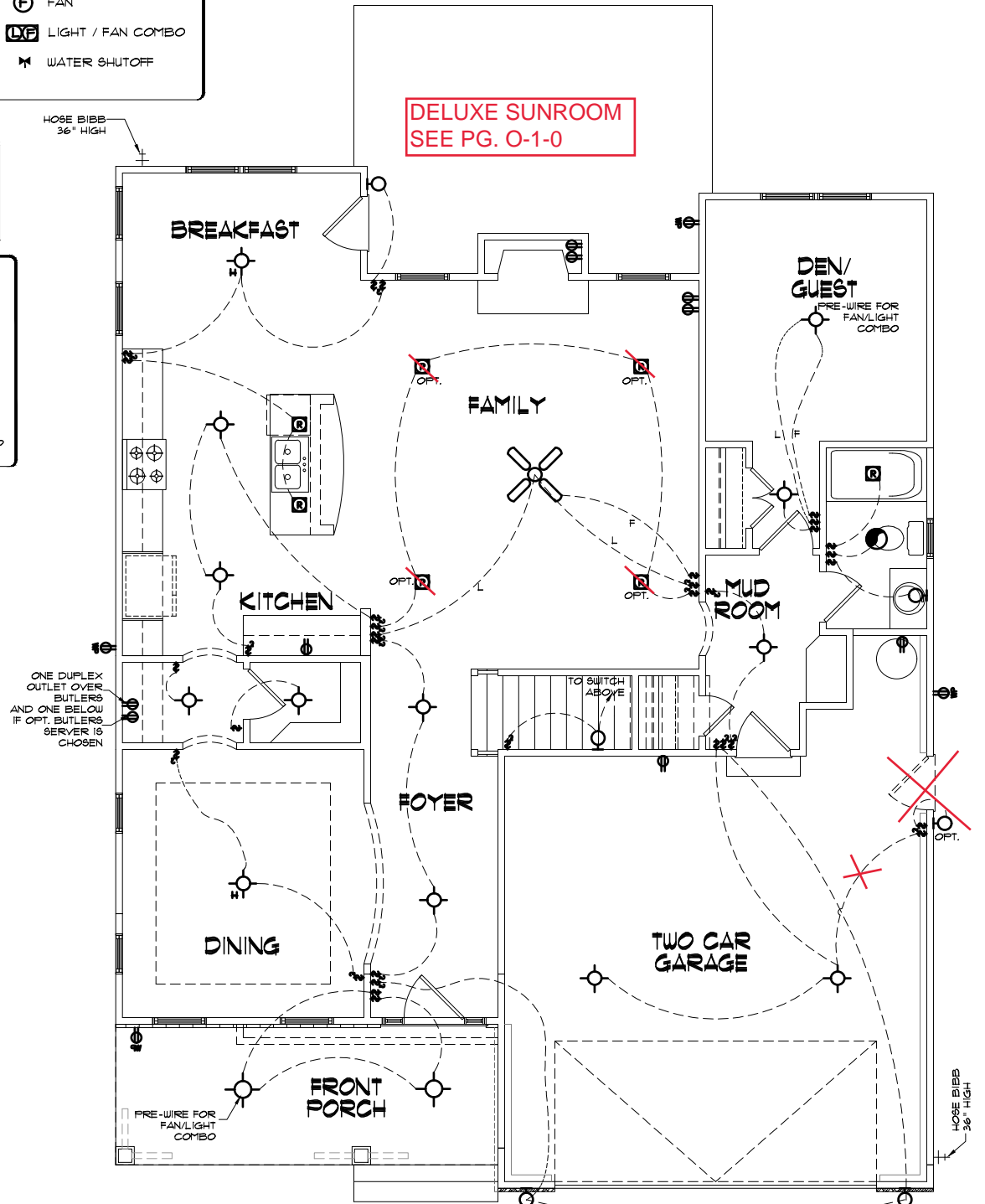

GENERAL NOTES: 1. THIS SET OF PLANS IS TO BE COORDINATED WITH ALL SET WORKS BY OTHER AND CONTRACTOR AND PER LOCAL CODES.
 2. CONTRACTOR IS TO VERIFY ALL CONDITIONS OF CONDITIONS OR OTHER VARIATIONS FROM DRAWING INFORMATION.
 3. MCKEE HOMES IS RESPONSIBLE FOR CONTRIBUTED VARIATIONS FROM THE INFORMATION REPORTED.
 4. MCKEE HOMES WILL ASSUME ANY AND ALL LIABILITY FOR ERRORS ASSOCIATED WITH ERRORS AND OMISSIONS ON THESE DRAWINGS HEREIN.
 5. THESE PLANS ARE FOR INFORMATIONAL PURPOSES ONLY. CONTRACTOR SHALL BE RESPONSIBLE FOR OBTAINING ALL NECESSARY PERMITS AND APPROVALS.

Mckee Homes, LLC
 Brooks II - Option - Euro
 Base Plan - Elev. E (RHG)
 Architectural Set - Master Plan (4-23-19)

PROGRESS DATE:	--
ISSUE DATE:	04/06/15
DRAWN BY:	A.S.H./B.B.
CHECKED BY:	A.S.H./B.B.
REVISIONS	
DATE:	BY: DESCRIP.
8-21-17	BB Master Plan Set - Archs
5-25-18	BB Master Plan Set - Archs
2-4-19	BB 2018 Codes - Plan mods
4-23-19	BB Full Plans for Opt. Plan Types

First & Second Floor
 Lighting Plans
 SHEET NO.
OE-7-0
 PLAN NO.
000112

ELECTRICAL SYMBOLS LEGEND

	WALL MOUNTED FIXTURE		DUPLEX OUTLET		SINGLE POLE SWITCH
	CEILING FIXTURE		SWITCHED OUTLET		3-WAY SWITCH
	HANGING FIXTURE		GROUND FAULT CIRCUIT-INTERRUPTER		4-WAY SWITCH
	FULL CHAIN FIXTURE		WATER PROOF OUTLET		DIMMER SWITCH
	RECESSED LIGHT		220 VOLT OUTLET		BATH FAN
	EYE BALL		FLOOR OUTLET		CEILING FAN
	FLOOD LIGHT		GARAGE DOOR OPENER		SMOKE DETECTOR
	KEYLESS FIXTURE		PHONE		FAN
	24x48 FLUORESCENT FIXTURE		CABLE TV		LIGHT / FAN COMBO
	12x48 FLUORESCENT FIXTURE		GARBAGE DISPOSAL		WATER SHUTOFF
	UNDER COUNTER LIGHTING		JUNCTION BOX		
			COMPUTER DATA OUTLET		

ELECTRICAL:

- 1) ALL ELECTRICAL DESIGN AND INSTALLATION IS TO CONFORM TO THE NATIONAL ELECTRICAL CODE, LATEST EDITION. ALL EQUIPMENT SHALL BE UL LABELED.
- 2) ALL SWITCHES TO BE MOUNTED 3'-10" ABOVE FINISHED FLOOR UNLESS OTHERWISE NOTED.
- 3) INSTALL CONVENIENCE OUTLETS AT 18" ABOVE FINISHED FLOOR, MAXIMUM SPACING 12'-0" O.C. INSTALL AT ALL WALLS OF 24" OR GREATER WIDTH.
- 4) UL SMOKE DETECTORS SHALL BE LOCATED IN ALL BEDROOMS, AND ONE EACH ADDITIONALLY AT EACH LEVEL. OTHER LOCATIONS SHOWN ON DRAWINGS. HARDWIRE ALL DETECTORS TOGETHER, AND PROVIDE BATTERY BACK-UP.
- 5) INSTALL GROUND FAULT RECEPTACLES IN BATHROOMS, KITCHENS, AND OTHER NET LOCATIONS AS REQUIRED BY N.E.C. 210-8.

ELECTRICAL NOTES

1. ELECTRICAL CONTRACTOR MUST CONFIRM ELECTRICAL LAYOUT WITH BUILDER AND/OR HOMEOWNER. BUILDER/HOMEOWNER SPECIFICATIONS WILL OVERRIDE THESE DOCUMENTS.
2. VERIFY LOCATION OF 240V. RECEPTACLES, AS GAS APPLIANCES MAY BE SUBSTITUTED FOR ELECTRICAL IN SOME CASES.

UPGRADED LIGHTING PACKAGE

1. ALL CEILING MOUNTS TO BE REPLACED WITH RECESSED CAN LIGHTS IN MAIN LIVING AREAS INCLUDING:
 - FAMILY
 - KITCHEN
 - HALLWAYS

NOTE: THIS PLAN ELEVATION PRODUCED BY GMD DESIGN GROUP, IS DERIVATIVE WORKS OF "THE BROOKS II" BY PLANWORK FOR MCKEE HOMES WITH WRITTEN PERMISSION OBTAINED BY THE BUILDER/OWNER FOR REPRODUCTION WITH MODIFICATION IN THE PURCHASE LETTER DATED "JANUARY 20th, 2014," ADDRESSED TO PAT MCKEE AT MCKEE HOMES. THE BUILDER/OWNER IS TO REVIEW AND APPROVE PLANS COORDINATION PRIOR TO CONSTRUCTION BEGINNING.

THIS IS MEANT TO BE AN OPTION SHEET, SEE ORIGINAL PLANS FOR MORE INFORMATION

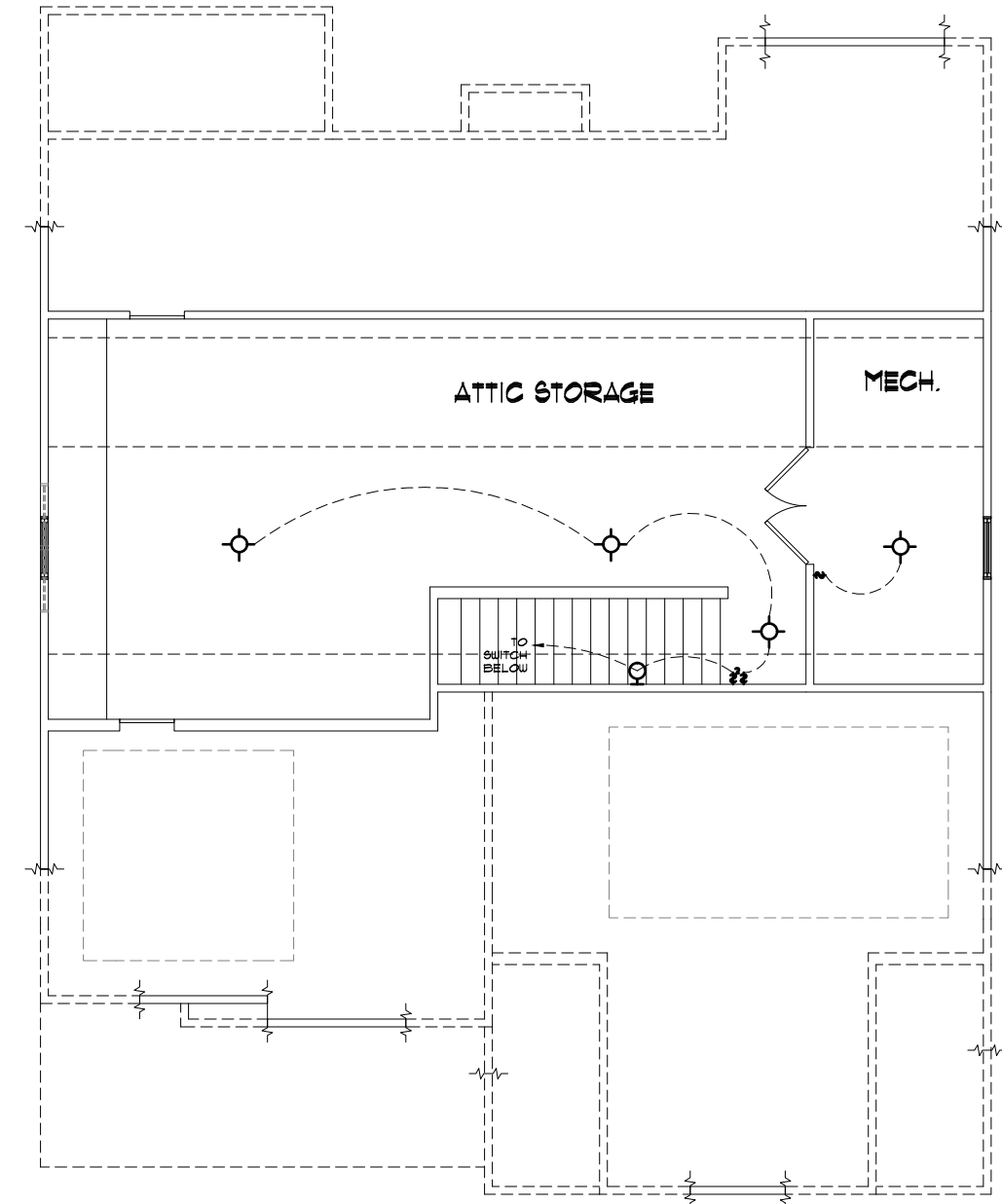

- 1) PLANS HAVE BEEN ISSUED TO MCKEE HOMES LLC, AS A BASE PLAN MASTER SET.
- 2) PLANS AND OPTIONS ARE DESIGNED FOR SINGLE USE ONLY AND NOT IN COMBINATION WITH EACH OTHER. THE USE OF MULTIPLE OPTIONS TOGETHER MAY CAUSE ADDITIONAL CHANGES TO ORIGINAL STRUCTURE AND ARCHITECTURAL DESIGNS.
3. ANY ON SITE CHANGES OR VARIATIONS FROM PLANS SHOWN MUST BE VERIFIED WITH DESIGNER OR ENGINEER TO MEET LOCAL CODES, GUIDELINES, LOAD CALCULATIONS ETC.

GENERAL NOTES: 1. THESE WORKS WILL ASSUME ANY AND ALL LIABILITY FOR ERRORS ASSOCIATED WITH ERRORS AND OMISSIONS ON THESE DRAWINGS HEREIN. 2. CONTRACTOR IS TO NOTIFY ARCHITECT IMMEDIATELY OF CONDITIONS OR ITEMS VARYING FROM DESIGNED INFORMATION. 3. THESE WORKS IS RESPONSIBLE FOR CONTRIBUTED VARIATIONS FROM THE INFORMATION EXPECTED. 4. THESE WORKS WILL ASSUME ANY AND ALL LIABILITY FOR ERRORS ASSOCIATED WITH ERRORS AND OMISSIONS ON THESE DRAWINGS HEREIN. 5. THESE WORKS IS RESPONSIBLE FOR ESTIMATING, MANAGING, OR RELOCATING CONTRACTOR COSTS ASSOCIATED WITH THESE TYPES.



Scales UNO:
22X34: 1/4"=1'-0"
11x17: 1/8"=1'-0"

Mckee Homes, LLC
Brooks II - Option - Euro
Base Plan - Elev. E (RHG)
Architectural Set - Master Plan (4-23-19)

PROGRESS DATE:	--	
ISSUE DATE:	04/06/15	
DRAWN BY:	A.S.H./B.B.	
CHECKED BY:	A.S.H./B.B.	
REVISIONS		
DATE	BY	DESCRPT.
8-21-17	BB	Master Plan Set - Archs
5-25-18	BB	Master Plan Set - Archs
2-4-19	BB	2018 Codes - Plan mods
4-23-19	BB	Full Elevs for Opt. Plan Types

Attic Floor & Optional Lighting
SHEET NO. OE-8-0
PLAN NO. 000112

NOTE: THIS PLAN ELEVATION PRODUCED BY GMD DESIGN GROUP, IS DERIVATIVE WORKS OF "THE BROOKS II" BY PLANWORK FOR MCKEE HOMES WITH WRITTEN PERMISSION OBTAINED BY THE BUILDER/OWNER FOR REPRODUCTION WITH MODIFICATION IN THE PURCHASE LETTER DATED "JANUARY 20th, 2014," ADDRESSED TO PAT MCKEE AT MCKEE HOMES. THE BUILDER/OWNER IS TO REVIEW AND APPROVE PLANS COORDINATION PRIOR TO CONSTRUCTION BEGINNING.

THIS IS MEANT TO BE AN OPTION SHEET, SEE ORIGINAL PLANS FOR MORE INFORMATION



LEFT ELEVATION
22x34 PRINTS SCALE: 1/4"=1'-0"
11x17 PRINTS SCALE: 1/8"=1'-0"



REAR ELEVATION
22x34 PRINTS SCALE: 1/4"=1'-0"
11x17 PRINTS SCALE: 1/8"=1'-0"



RIGHT ELEVATION
22x34 PRINTS SCALE: 1/4"=1'-0"
11x17 PRINTS SCALE: 1/8"=1'-0"

ELECTRICAL NOTES
1. ELECTRICAL CONTRACTOR MUST CONFIRM ELECTRICAL LAYOUT WITH BUILDER AND/OR HOMEOWNER. BUILDER/HOMEOWNER SPECIFICATIONS WILL OVERRIDE THESE DOCUMENTS.
2. VERIFY LOCATION OF 240V. RECEPTACLES, AS GAS APPLIANCES MAY BE SUBSTITUTED FOR ELECTRICAL IN SOME CASES.

ELECTRICAL:
1) ALL ELECTRICAL DESIGN AND INSTALLATION IS TO CONFORM TO THE NATIONAL ELECTRICAL CODE, LATEST EDITION. ALL EQUIPMENT SHALL BE UL LABELED.
2) ALL SWITCHES TO BE MOUNTED 5'-10" ABOVE FINISHED FLOOR UNLESS OTHERWISE NOTED.
3) INSTALL CONVENIENCE OUTLETS AT 18" ABOVE FINISHED FLOOR, MAXIMUM SPACING 12'-0" O.C. INSTALL AT ALL WALLS OF 24" OR GREATER WIDTH.
4) UL SMOKE DETECTORS SHALL BE LOCATED IN ALL BEDROOMS, AND ONE EACH ADDITIONALLY AT EACH LEVEL, OTHER LOCATIONS SHOWN ON DRAWINGS. HARDWARE ALL DETECTORS TOGETHER, AND PROVIDE BATTERY BACK-UP.
5) INSTALL GROUND FAULT RECEPTACLES IN BATHROOMS, KITCHENS, AND OTHER KEY LOCATIONS AS REQUIRED BY N.E.C. 210-8.

BROOKS II - OPTIONAL DELUXE SUNROOM

Heated Square Footage	
Sunroom - Deluxe	203
Total =	203
Unheated Square Footage	
Covered Porch - Rear	93

WINDOW FALL PREVENTION PROTECTION
IF ANY PART OF THE CLEAR OPENING OF THE OPERABLE PORTION OF A WINDOW IS LOCATED MORE THAN 12" ABOVE THE EXTERIOR GRADE THEN THE LOWEST PART OF THE CLEAR OPENING MUST BE AT LEAST 24" ABOVE THE FLOOR OF THE ROOM IN WHICH IT IS LOCATED.
EXCEPTIONS:
1. THE WINDOW IS A FIXED UNIT.
2. THE OPENING DOES NOT ALLOW THE PASSAGE OF A 4- INCH DIAMETER SPHERE.
3. THE WINDOW IS EQUIPPED WITH A WINDOW FALL PREVENTION DEVICE MEETING ASTM F2090.
4. THE WINDOW IS EQUIPPED WITH AN APPROVED WINDOW OPENING LIMITING DEVICE.
NOTE: WHEN USED WITH AN EMERGENCY ESCAPE AND RESCUE WINDOW, OPENING LIMITING DEVICES AND FALL PREVENTION DEVICES MUST BE APPROVED FOR EMERGENCY ESCAPE AND RESCUE PROVISIONS.

GENERAL NOTES
WALL THICKNESS / ANGLES
ALL EXTERIOR STUD WALLS ARE DRAWN 4" THICK UNO.
ALL INTERIOR STUD WALLS ARE DRAWN 4" THICK UNO.
ANGLED WALLS ARE DRAWN @ 45° UNO.
EGRESS
ALL BEDROOMS MUST HAVE AT LEAST ONE WINDOW WHICH CONFORMS TO EGRESS REQUIREMENTS FOR CLEAR OPENING HEIGHT AND WIDTH. IT IS THE CONTRACTOR'S RESPONSIBILITY TO VERIFY EGRESS SIZING PER CODE BASED ON CHOSEN MANUFACTURER, AS PRODUCT SIZES MAY VARY.
WALL/CEILING HEIGHTS
WALL AND CEILING HEIGHTS NOTES ARE BASED ON NOMINAL WALL SIZE (I.E. A 9'-1 1/8" ACTUAL WALL HEIGHT IS LABELED 9/0 ON THE DRAWING).
ALL VAULTED OR SLOPED CEILING ARE TO BE FURRED DOWN TO ACCOMMODATE REQUIRED CEILING INSULATION AND 1" AIRSPACE. VERIFY CODES FOR INFORMATION ON INSULATION REQUIREMENTS.
STAIRS
STAIR TREADS ARE MEASURED FROM NOSING TO NOSING (N.N).
MAXIMUM STAIR RISE HEIGHT TO BE NO GREATER THAN 8-1/4"

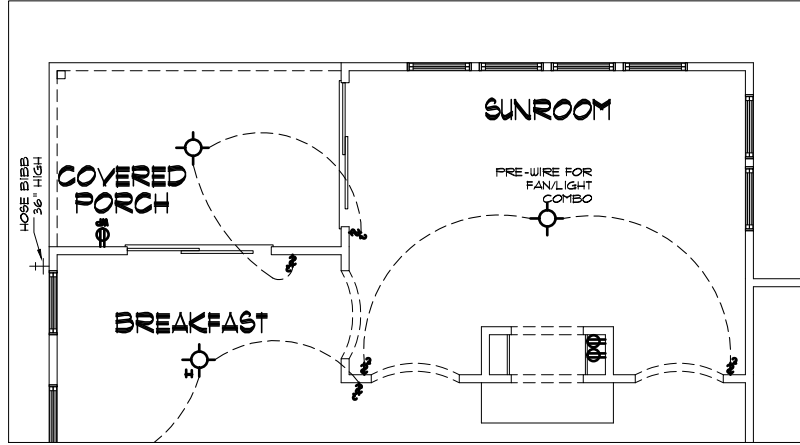

DELUXE SUNROOM/COV. PORCH LIGHTING PLAN
22x34 PRINTS SCALE: 1/4"=1'-0"
11x17 PRINTS SCALE: 1/8"=1'-0"

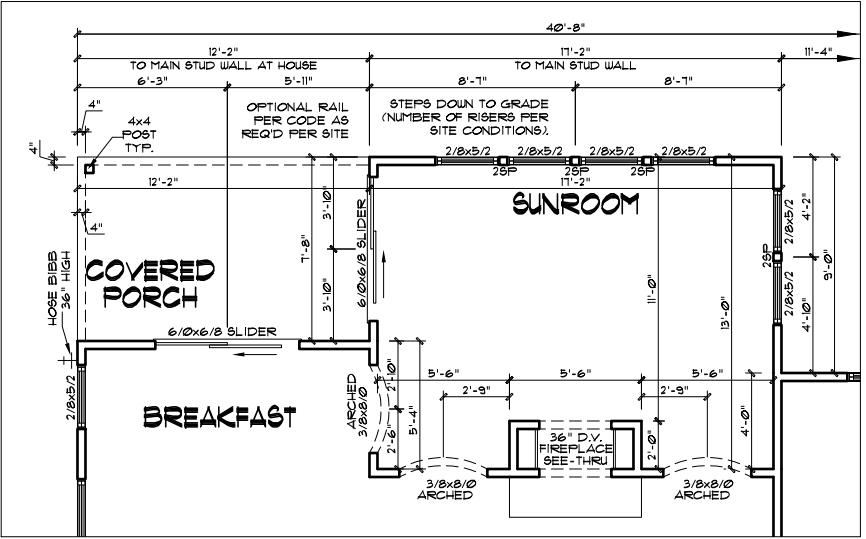

DELUXE SUNROOM/COV. PORCH FIRST FLOOR PLAN
22x34 PRINTS SCALE: 1/4"=1'-0"
11x17 PRINTS SCALE: 1/8"=1'-0"

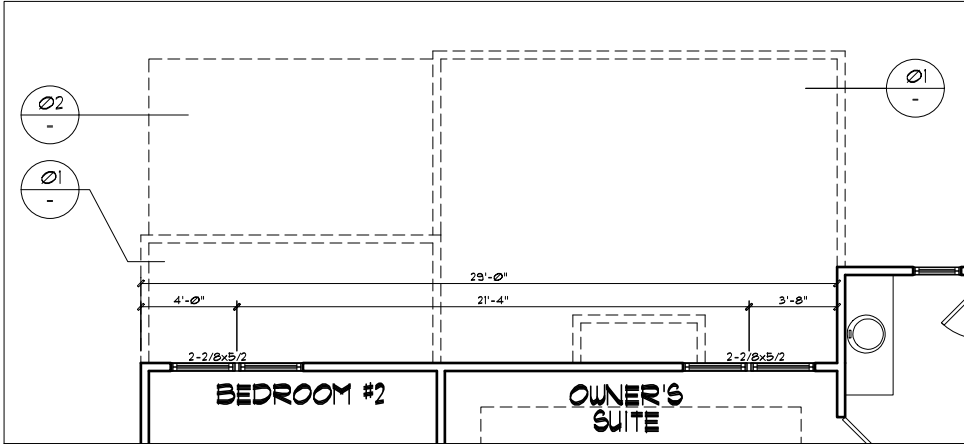

DELUXE SUNROOM/COV. PORCH SECOND FLOOR PLAN
22x34 PRINTS SCALE: 1/4"=1'-0"
11x17 PRINTS SCALE: 1/8"=1'-0"

1) PLANS HAVE BEEN ISSUED TO MCKEE HOMES LLC, AS A BASE PLAN MASTER SET.
2) PLANS AND OPTIONS ARE DESIGNED FOR SINGLE USE ONLY AND NOT IN COMBINATION WITH EACH OTHER. THE USE OF MULTIPLE OPTIONS TOGETHER MAY CAUSE ADDITIONAL CHANGES TO ORIGINAL STRUCTURE AND ARCHITECTURAL DESIGN.
3. ANY ON SITE CHANGES OR VARIATIONS FROM PLANS SHOULD BE VERIFIED WITH DESIGNER OR ENGINEER TO MEET LOCAL CODES, GUIDELINES, LOAD CALCULATIONS ETC.



Scales UNO:
22X34: 1/4"=1'-0"
11X17: 1/8"=1'-0"

McKee Homes, LLC
Brooks II - Base - Options
Base Plan - Right Hand Garage
Architectural Set - Master Plan (4-23-19)

PROGRESS DATE:		---
ISSUE DATE:	04/06/15	
DRAWN BY:	ASH/BB	
CHECKED BY:	ASH/BB	
REVISIONS		
DATE	BY	DESCRPT.
8-21-17	BB	Master Plan Set - Arch
5-25-18	BB	Master Plan Set - Arch
2-4-19	BB	2018 Codes - Plan mods
4-23-19	BB	Full Plans for Opt. Plan Types

Opt Deluxe Sunroom
-Elevs-Firs-Lights
SHEET NO.
0-1-0
PLAN NO.
000112

4. MCKEE HOMES WILL ASSUME ANY AND ALL LIABILITY FOR ERRORS ASSOCIATED WITH ERRORS AND OMISSIONS ON THESE DRAWINGS HEREIN.
 5. THESE PLANS ARE NOT TO BE USED FOR ESTIMATING, PERMITTING, OR CONTRACTING COSTS ASSOCIATED WITH THESE PLANS.
 GENERAL NOTES: THESE PLANS ARE TO BE COORDINATED WITH ALL OTHER INFORMATION BY OWNER AND CONTRACTOR AND FOR LABEL CODES.
 2. CONTRACTOR IS TO NOTIFY ARCHITECT IMMEDIATELY OF CONDITIONS OR ITEMS VARYING FROM DRAWING INFORMATION.
 3. MCKEE HOMES IS RESPONSIBLE FOR CONTRIBUTED VARIATIONS FROM THE INFORMATION SUPPLIED.

* 1 HOUR RATED (PRESCRIPTIVE 133 HR) W/ (2) LAYERS 5/8" TYPE X GYP BD. AT UNDERSIDE OF SOFFIT/RAKE AS REQUIRED. SEE PLANS FOR LOCATIONS. USE EXTERIOR GRADE (G-P FIREGUARD EXTERIOR OR EQUAL) UNDER FINISHED NON-VENTED SOFFIT.

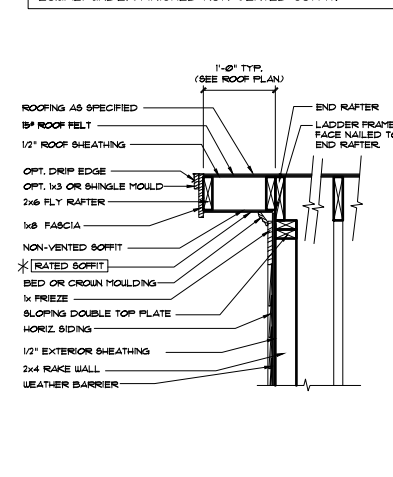

9 RAKE OVERHANG - STICK
1/4\"/>

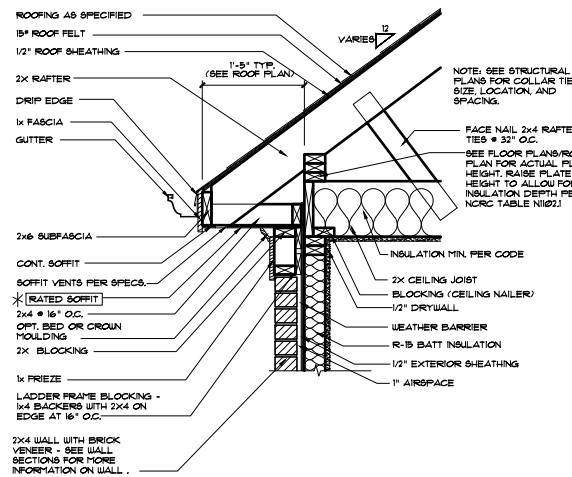

8 CORNICE AT BRICK STICK
1/4\"/>

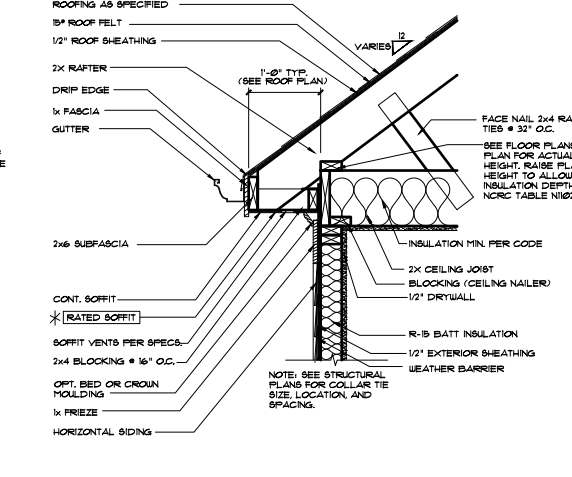

7 CORNICE AT SIDING (STICK)
1/4\"/>

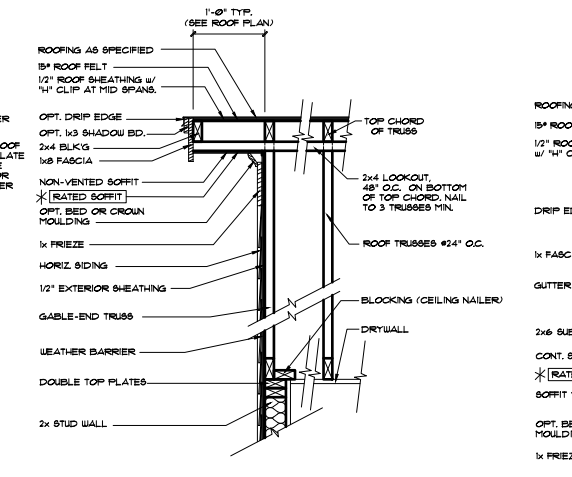

6 RAKE OVERHANG - (TRUSSES)
1/4\"/>

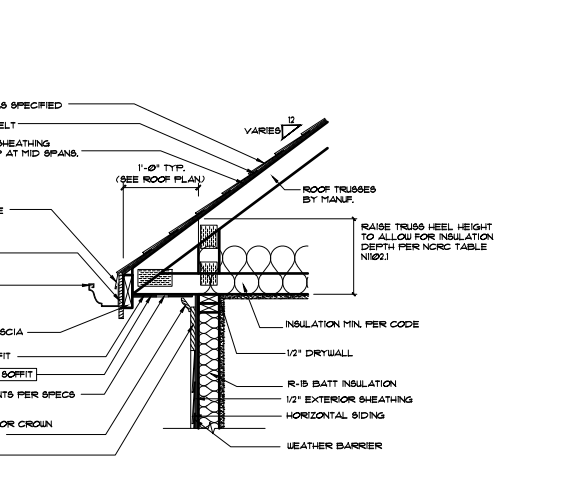

5 CORNICE AT SIDING (TRUSSES)
1/4\"/>

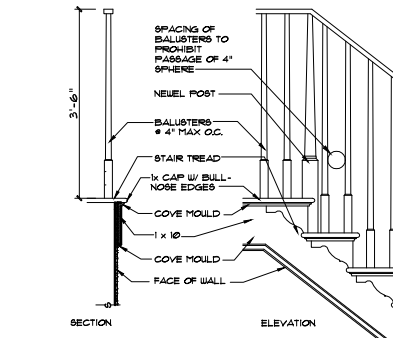

4 STAIR TRIM - OPEN RISERS
1/4\"/>

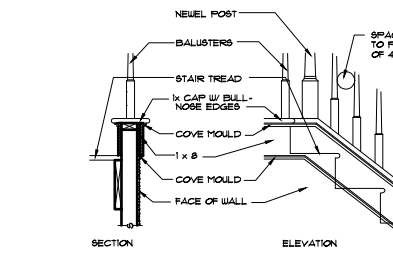

3 STAIR TRIM - CLOSED RISERS
1/4\"/>

* SEE STRUCTURAL SHEETS, NOTES AND DETAILS FOR MORE INFORMATION. ALL STRUCTURAL INFORMATION OVER-RIDES THESE ARCHITECTURAL DETAILS

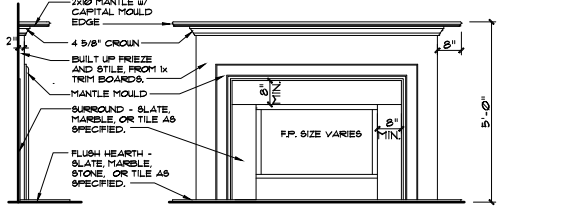

2 FIREPLACE TRIM
1/2\"/>

ACCEPTABLE MANUFACTURER: G-P DENSE GL455 GOLD FIREGUARD EXTERIOR GUARD OR EQUAL.

GA FILE NO. WP 8105	GENERIC	1 HOUR FIRE
GYPSUM WALLBOARD, GYPSUM SHEATHING, WOOD STUDS		
EXTERIOR SIDE: One layer 48" wide 1/2" type X gypsum sheathing applied parallel to 2 x 4 wood studs with 1 1/2" galvanized roofing nails, 0.120" shank, 7/16" or 1/2" heads, 4" o.c. at vertical joints and 7" o.c. at intermediate studs and top and bottom plates. Joints of gypsum sheathing may be left untreated. Exterior cladding to be attached through sheathing to studs.		
INTERIOR SIDE: One layer 1/2" type X gypsum wallboard, water-resistant gypsum backing board, or gypsum veneer base applied parallel or at right angles to studs with 6d coated nails, 1 1/4" long, 0.0915" shank, 1/2" heads, 7" o.c. (LOAD-BEARING)		
Thickness:	Varies	
Approx. Weight:	7 pcf	
Fire Test:	See WP 3510 (UL R3501-47, -48, 9-17-65, UL Design U309, UL 11919-129, 7-22-70, UL Design U314)	

- 1) PLANS HAVE BEEN ISSUED TO MCKEE HOMES LLC. AS A BASE PLAN MASTER SET.
- 2) PLANS AND OPTIONS ARE DESIGNED FOR SINGLE USE ONLY AND NOT IN COMBINATION WITH EACH OTHER. THE USE OF MULTIPLE OPTIONS TOGETHER MAY CAUSE ADDITIONAL CHANGES TO ORIGINAL STRUCTURE AND ARCHITECTURAL DESIGNS.
3. ANY ON SITE CHANGES OR VARIATIONS FROM PLANS SHOWN MUST BE VERIFIED WITH DESIGNER OR ENGINEER TO MEET LOCAL CODES, GUIDELINES, LOAD CALCULATIONS ETC.

WALL SECTION DETAILS

MASTER DETAIL	DETAIL VARIATIONS			

FLOOR SECTION DETAILS

MASTER DETAIL	DETAIL VARIATIONS			



Scales UNO:
22X34: 1/4"=1'-0"
11x17: 1/8"=1'-0"

GENERAL NOTES: 1. THESE DETAILS ARE TO BE COORDINATED WITH ALL OTHER MEMBERSHIPS BY OWNER AND CONTRACTOR. 2. CONTRACTOR IS TO VERIFY ARCHITECT PREPARED CONDITIONS OR ITEMS VARYING FROM SPECIFIED INFORMATION. 3. THESE WORKS ARE RESPONSIBLE FOR CONTRIBUTED VARIATIONS FROM THE INFORMATION SPECIFIED. 4. MCKEE HOMES WILL ASSUME ANY AND ALL LIABILITY FOR ERRORS AND OMISSIONS ON THESE DRAWINGS HEREIN. 5. THESE DETAILS ARE FOR GENERAL INFORMATION ONLY. CONTRACTOR SHALL VERIFY ALL CONDITIONS AND MATERIALS.

McKee Homes, LLC
 Brooks II - Base - Options
 Base Plan - Right Hand Garage
 Architectural Set - Master Plan (4-23-19)

PROGRESS DATE:	--	
ISSUE DATE:	04/06/15	
DRAWN BY:	ASH/BB	
CHECKED BY:	ASH/BB	
REVISIONS		
DATE:	BY:	DESCRPT.
8-21-17	BB	Master Plan Set - Archs
5-25-18	BB	Master Plan Set - Archs
2-4-19	BB	2018 Codes - Plan mods
4-23-19	BB	Full Plans for Opt. Plan Types
Architectural Details		
SHEET NO. AD-1		
PLAN NO. 000112		

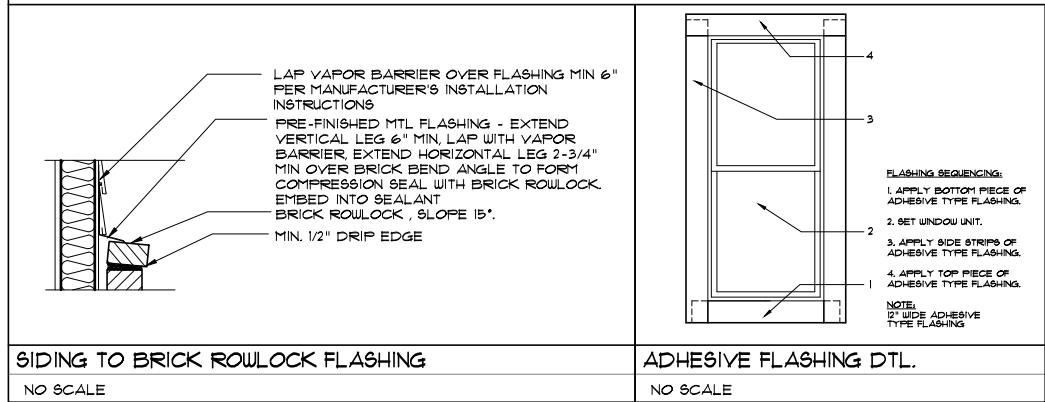
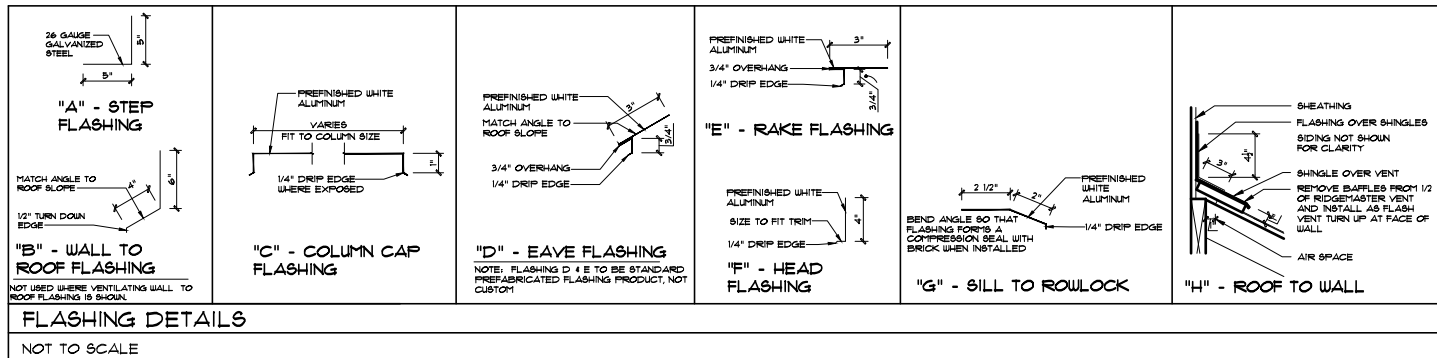

* SEE STRUCTURAL SHEETS, NOTES AND DETAILS FOR MORE INFORMATION. ALL STRUCTURAL INFORMATION OVER-RIDES THESE ARCHITECTURAL DETAILS

1) PLANS HAVE BEEN ISSUED TO MCKEE HOMES LLC, AS A BASE PLAN MASTER SET.
2) PLANS AND OPTIONS ARE DESIGNED FOR SINGLE USE ONLY AND NOT IN COMBINATION WITH EACH OTHER. THE USE OF MULTIPLE OPTIONS TOGETHER MAY CAUSE ADDITIONAL CHANGES TO ORIGINAL STRUCTURE AND ARCHITECTURAL DESIGNS.
3. ANY ON SITE CHANGES OR VARIATIONS FROM PLANS SHOWN MUST BE VERIFIED WITH DESIGNER OR ENGINEER TO MEET LOCAL CODES, GUIDELINES, LOAD CALCULATIONS ETC.

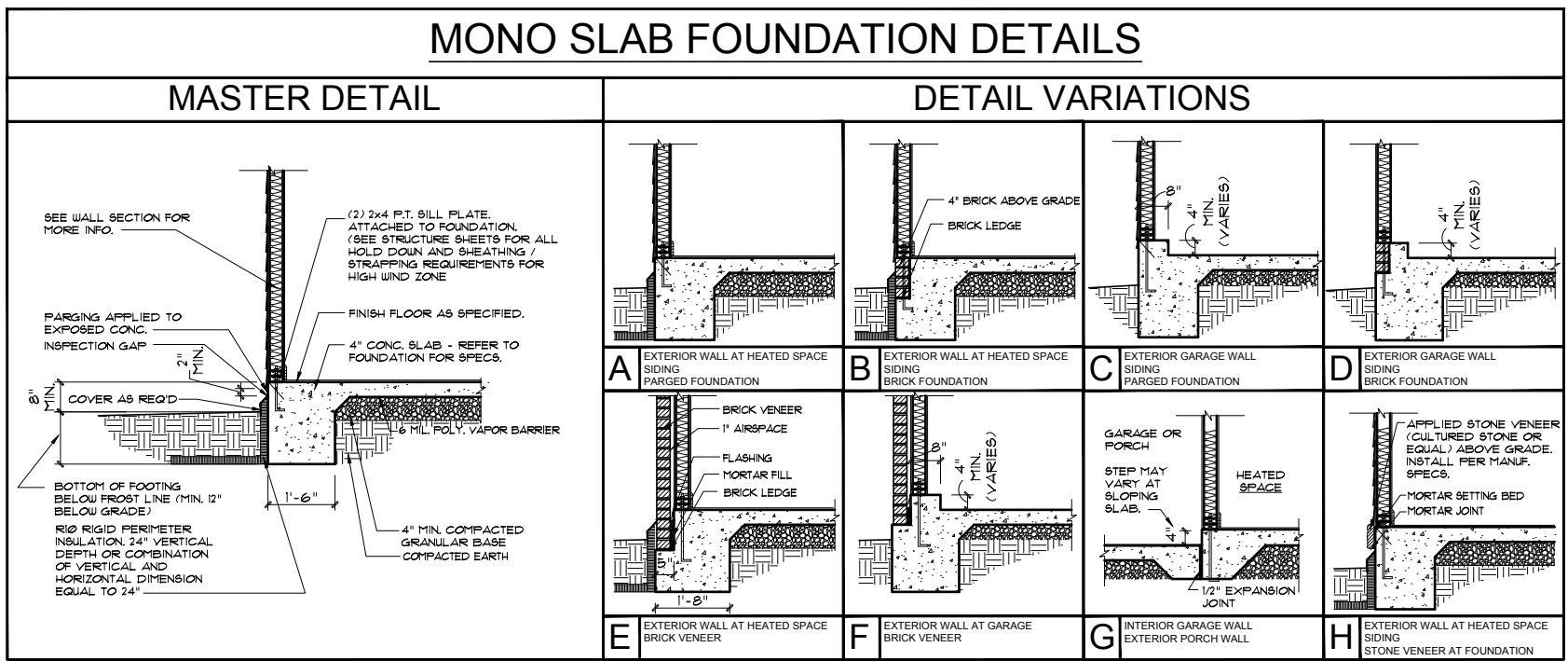
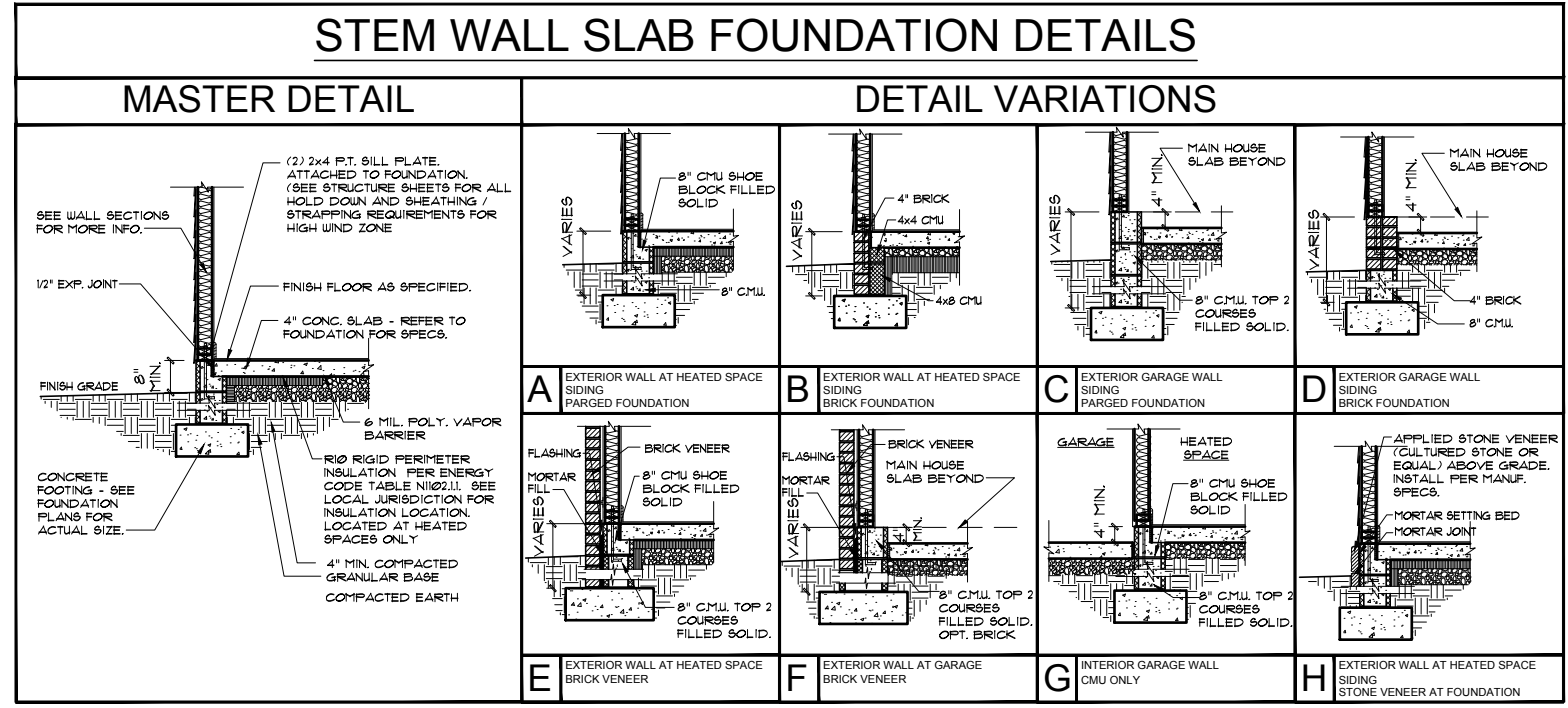

Scales UNO:
22X34: 1/4"=1'-0"
11x17: 1/8"=1'-0"

GENERAL NOTES: 1. THESE DETAILS ARE TO BE COORDINATED WITH ALL OTHER INFORMATION BY OWNER AND CONTRACTOR. 2. CONTRACTOR IS TO VERIFY ALL DIMENSIONS AND CONDITIONS OF THE WORK BEFORE BEGINNING WORK. 3. THESE DETAILS ARE FOR INFORMATION ONLY. 4. THESE DETAILS ARE FOR INFORMATION ONLY. 5. THESE DETAILS ARE FOR INFORMATION ONLY.

McKee Homes, LLC
Brooks II - Base - Options
Base Plan - Right Hand Garage
Architectural Set - Master Plan (4-23-19)

PROGRESS DATE:	---
ISSUE DATE:	04/06/15
DRAWN BY:	A.S.H./B.B.
CHECKED BY:	A.S.H./B.B.
REVISIONS	
DATE:	BY: DESCRPT.
8-21-17	BB Master Plan Set - Arch
5-25-18	BB Master Plan Set - Arch
2-4-19	BB 2018 Codes - Plan mods
4-23-19	BB Full Plans for Opt. Plan Types
Architectural Details	
SHEET NO.	
AD-2	
PLAN NO.	
000112	

DESIGN SPECIFICATIONS:

Construction Type: Commercial Residential

Applicable Building Codes:

- 2018 North Carolina Residential Building Code with All Local Amendments
• ASCE 7-10: Minimum Design Loads for Buildings and Other Structures

Design Loads:

- 1. Roof Live Loads
11. Conventional 2x 20 PSF
12. Truss 20 PSF
12.1. Attic Truss 60 PSF
2. Roof Dead Loads
2.1. Conventional 2x 10 PSF
2.2. Truss 20 PSF
3. Snow
3.1. Importance Factor 1.0
4. Floor Live Loads
4.1. Typ. Dwelling 40 PSF
4.2. Sleeping Areas 30 PSF
4.3. Decks 40 PSF
4.4. Passenger Garage 50 PSF
5. Floor Dead Loads
5.1. Conventional 2x 10 PSF
5.2. I-Joist 15 PSF
5.3. Floor Truss 15 PSF
6. Ultimate Design Wind Speed (3 sec. gust) 130 MPH
6.1. Exposure B
6.2. Importance Factor 1.0
6.3. Wind Base Shear
6.3.1. Vx =
6.3.2. Vy =

7. Component and Cladding (in PSF)

Table with 5 columns: MEAN ROOF HT., UP TO 30', 30'-35', 35'-40', 40'-45'. Rows for ZONE 1 through ZONE 5.

8. Seismic

- 8.1. Site Class D
8.2. Design Category C
8.3. Importance Factor 1.0
8.4. Seismic Use Group I
8.5. Spectral Response Acceleration
8.5.1. Ss = %g
8.5.2. Sm = %g
8.6. Seismic Base Shear
8.6.1. Vx =
8.6.2. Vy =
8.7. Basic Structural System (check one)
[] Bearing Wall
[] Building Frame
[] Moment Frame
[] Dual w/ Special Moment Frame
[] Dual w/ Intermediate R/C or Special Steel
[] Inverted Pendulum
8.8. Arch/Mech Components Anchored No
8.9. Lateral Design Control: Seismic [] Wind [x]
9. Assumed Soil Bearing Capacity 20000psf



STRUCTURAL PLANS PREPARED FOR:

BROOKS II

PROJECT ADDRESS: TBD
OWNER: McKee Homes
109 Hay St., Suite 301
Fayetteville, NC 28301

DESIGNER: Planwork Architecture PA
5111 Six Forks Rd. #100
Raleigh, NC 27609

These drawings are to be coordinated with the architectural, mechanical, plumbing, electrical, and civil drawings. This coordination is not the responsibility of the structural engineering of record (SER). Should any discrepancies become apparent, the contractor shall notify SUMMIT Engineering, Laboratory & Testing, P.C. before construction begins.

PLAN ABBREVIATIONS:

Table with 4 columns: AB, AFF, CJ, CLR, DJ, D&P, EE, EW, NTS, OC, P&F, P&I. Rows for ANCHOR BOLT, ABOVE FINISHED FLOOR, CEILING JOIST, CLEAR, DOUBLE JOIST, DOUBLE STUD POCKET, EACH END, EACH WAY, NOT TO SCALE, ON CENTER, POUNDS PER SQUARE FOOT, POUNDS PER SQUARE INCH, PT, RS, SC, SJ, SFP, STY, TJ, TRIPLE JOIST, TRIPLE STUD POCKET, TYP, UNLESS NOTED OTHERWISE, WLF.

Roof truss and floor joist layouts, and their corresponding loading details, were not provided to SUMMIT Engineering, Laboratory & Testing, P.C. (SUMMIT) prior to the initial design. Therefore, truss and joist directions were assumed based on the information provided by MCKEE HOMES. Subsequent plan revisions based on roof truss and floor joist layouts shall be noted in the revision list, indicating the date the layouts were provided. Should any discrepancies become apparent, the contractor shall notify SUMMIT immediately.

SHEET LIST:

Table with 2 columns: Sheet No., Description. Rows for CSI, SLOm, SLOs, SLOc, SLOb, SLO, SLO, SLO, SLO, SLO.

REVISION LIST:

Table with 4 columns: Revision No., Date, Project No., Description. Rows for 1, 2, 3, 4.

GENERAL STRUCTURAL NOTES:

- 1. The design professional whose seal appears on these drawings is the structural engineer of record (SER) for this project. The SER bears the responsibility of the primary structural elements and the performance of this structure. No other party may revise, alter, or delete any structural aspects of these construction documents without written permission of SUMMIT Engineering, Laboratory & Testing, P.C. (SUMMIT) or the SER. For the purposes of these construction documents the SER and SUMMIT shall be considered the same entity.
2. The structure is only stable in its completed form. The contractor shall provide all required temporary bracing during construction to stabilize the structure.
3. The SER is not responsible for construction sequences, methods, or techniques in connection with the construction of this structure. The SER will not be held responsible for the contractor's failure to conform to the contract documents, should any non-conformities occur.
4. Any structural elements or details not fully developed on the construction drawings shall be completed under the direction of a licensed professional engineer. These shop drawings shall be submitted to SUMMIT for review before any construction begins. The shop drawings will be reviewed for overall compliance as it relates to the structural design of this project. Verification of the shop drawings for dimensions, or for actual field conditions, is not the responsibility of the SER or SUMMIT.
5. Verification of assumed field conditions is not the responsibility of the SER. The contractor shall verify the field conditions for accuracy and report any discrepancies to SUMMIT before construction begins.
6. The SER is not responsible for any secondary structural elements or non-structural elements, except for the elements specifically noted on the structural drawings.
7. This structure and all construction shall conform to all applicable sections of the International Residential code.
8. This structure and all construction shall conform to all applicable sections of local building codes.
9. All structural assemblies are to meet or exceed to requirements of the current local building code.

FOUNDATIONS:

- 1. The structural engineer has not performed a subsurface investigation. Verification of this assumed value is the responsibility of the owner or the contractor. Should any adverse soil condition be encountered the SER must be contacted before proceeding.

- 2. The bottom of all footings shall extend below the frost line for the region in which the structure is to be constructed. However, the bottom of all footings shall be a minimum of 12" below grade.
3. Any fill shall be placed under the direction or recommendation of a licensed professional engineer.
4. The resulting soil shall be compacted to a minimum of 95% maximum dry density.
5. Excavations of footings shall be lined temporarily with a 6 mil polyethylene membrane if placement of concrete does not occur within 24 hours of excavation.
6. No concrete shall be placed against any subgrade containing water, ice, frost, or loose material.

STRUCTURAL STEEL:

- 1. Structural steel shall be fabricated and erected in accordance with the American Institute of Steel Construction "Code of Standard Practice for Steel Buildings and Bridges" and the manual of Steel Construction "Load Resistance Factor Design" latest editions.
2. Structural steel shall receive one coat of shop applied rust-inhibitive paint.
3. All steel shall have a minimum yield stress (Fy) of 36 ksi unless otherwise noted.
4. Welding shall conform to the latest edition of the American Welding Society's Structural Welding Code AWS D11. Electrodes for shop and field welding shall be class E70XX. All welding shall be performed by a certified welder per the above standards.

CONCRETE:

- 1. Concrete shall have a normal weight aggregate and a minimum compressive strength (fc) at 28 days of 3000 psi, unless otherwise noted on the plan.
2. Concrete shall be proportioned, mixed, and placed in accordance with the latest editions of ACI 318: "Building Code Requirements for Reinforced Concrete" and ACI 301: "Specifications for Structural Concrete for Buildings".
3. Air entrained concrete must be used for all structural elements exposed to freeze/thaw cycles and deicing chemicals. Air entrainment amounts (in percent) shall be within -1% to +2% of target values as follows:
3.1. Footings: 5%
3.2. Exterior Slabs: 5%
4. No admixtures shall be added to any structural concrete without written permission of the SER.

- 5. Concrete slabs-on-grade shall be constructed in accordance with ACI 302.1R-96: "Guide for Concrete Slab and Slab Construction".
6. The concrete slab-on-grade has been designed using a subgrade modulus of k=250 pci and a design loading of 200 psf. The SER is not responsible for differential settlement, slab cracking or other future defects resulting from unreported conditions not in accordance with the above assumptions.
7. Control or saw cut joints shall be spaced in interior slabs-on-grade at a maximum of 15'-0" O.C. and in exterior slabs-on-grade at a maximum of 10'-0" unless otherwise noted.
8. Control or saw cut joints shall be produced using conventional process within 4 to 12 hours after the slab has been finished.
9. Reinforcing steel may not extend through a control joint. Reinforcing steel may extend through a saw cut joint.
10. All welded wire fabric (WWF) for concrete slabs-on-grade shall be placed at mid-depth of slab. The WWF shall be securely supported during the concrete pour.

CONCRETE REINFORCEMENT:

- 1. Fibrous concrete reinforcement, or fibermesh specified in concrete slabs-on-grade may be used for control of cracking due to shrinkage and thermal expansion/contraction, lowered water migration, an increase in impact capacity, increased abrasion resistance, and residual strength.
2. Fibermesh reinforcing to be 100% virgin polypropylene fibers containing no reprocessed olefin materials and specifically manufactured for use as concrete secondary reinforcement.
3. Application of fibermesh per cubic yard of concrete shall equal a minimum of 0.1% by volume (15 pounds per cubic yard).
4. Fibermesh shall comply with ASTM C116, any local building code requirements, and shall meet or exceed the current industry standard.
5. Steel reinforcing bars shall be new billet steel conforming to ASTM A615, grade 60.
6. Detailing, fabrication, and placement of reinforcing steel shall be in accordance with the latest edition of ACI 318: "Manual of Standard Practice for Detailing Concrete Structures".
7. Horizontal footing and wall reinforcement shall be continuous and shall have 90 degree bends, or corner bars with the same size/spacing as the horizontal reinforcement with a class B tension splice.
8. Lap reinforcement as required, a minimum of 40 bar diameters for tension or compression unless otherwise noted. Splices in masonry shall be a minimum of 48 bar diameters.

- 9. Where reinforcing dowels are required, they shall be equivalent in size and spacing to the vertical reinforcement. The dowel shall extend 48 bar diameters vertically and 20 bar diameters into the footing.
10. Where reinforcing steel is required vertically, dowels shall be provided unless otherwise noted.

WOOD FRAMING:

- 1. Solid saun wood framing members shall conform to the specifications listed in the latest edition of the "National Design Specification for Wood Construction" (NDS). Unless otherwise noted, all wood framing members are designed to be Southern-Yellow-Pine (SYP) #2.
2. LVL or PSL engineered wood shall have the following minimum design values:
2.1. E = 1900000 psi
2.2. Fb = 2600 psi
2.3. Fv = 285 psi
2.4. Fc = 100 psi
3. Wood in contact with concrete, masonry, or earth shall be pressure treated in accordance with AWPFA standard C-15. All other moisture exposed wood shall be treated in accordance with AWPFA standard C-2.
4. Nails shall be common wire nails unless otherwise noted.
5. Lag screws shall conform to ANSI/ASME standard B18.21-1981. Lead holes for lag screws shall be in accordance with NDS specifications.
6. All beams shall have full bearing on supporting framing members unless otherwise noted.
7. Exterior and load bearing stud walls are to be 2x4 SYP #2 @ 16" O.C. unless otherwise noted. Studs shall be continuous from the sole plate to the double top plate. Studs shall only be discontinuous at headers for window/door openings. A minimum of one king stud shall be placed at each end of the header. King studs shall be continuous.
8. Individual studs forming a column shall be attached with one 10d nail @ 6" O.C. staggered. The stud column shall be continuous to the foundation or beam. The column shall be properly blocked at all floor levels to ensure proper load transfer.
9. Multi-ply beams shall have each ply attached with (3) 10d nails @ 24" O.C.
10. Four and five ply beams shall be bolted together with (2) rows of 1/2" diameter through bolts staggered @ 16" O.C. unless noted otherwise.

WOOD TRUSSES:

- 1. The wood truss manufacturer/fabricator is responsible for the design of the wood trusses. Submit sealed shop drawings and supporting calculations to the SER for review prior to fabrication. The SER shall have a minimum of five (5) days for review. The review by the SER shall review for overall compliance with the design documents. The SER shall assume no responsibility for the correctness for the structural design for the wood trusses.
2. The wood trusses shall be designed for all required loadings as specified in the local building code, the ASCE Standard "Minimum Design Loads for Buildings and Other Structures," (ASCE 7-10), and the loading requirements shown on these specifications. The truss drawings shall be coordinated with all other construction documents and provisions provided for loads shown on these drawings including but not limited to HVAC equipment, piping, and architectural fixtures attached to the trusses.
3. The trusses shall be designed, fabricated, and erected in accordance with the latest edition of the "National Design Specification for Wood Construction" (NDS) and "Design Specification for Metal Plate Connected Wood Trusses." (ASCE 7-10), and the loading requirements shown on these specifications. The truss manufacturer shall provide adequate bracing information in accordance with "Commentary and Recommendations for Handling, Installing, and Bracing Metal Plate Connected Wood Trusses" (HIB-9). This bracing, both temporary and permanent, shall be shown on the shop drawings. Also, the shop drawings shall show the required attachments for the trusses.
5. Any chords or truss webs shown on these drawings have been shown as a reference only. The final design of the trusses shall be per the manufacturer.

EXTERIOR WOOD FRAMED DECKS:

- 1. Decks are to be framed in accordance with local building codes and as referenced on the structural plans, either through code references or construction details.

WOOD STRUCTURAL PANELS:

- 1. Fabrication and placement of structural wood sheathing shall be in accordance with the APA Design/Construction Guide "Residential and Commercial," and all other applicable APA standards.
2. All structurally required wood sheathing shall bear the mark of the APA.

- 3. Wood wall sheathing shall comply with the requirements of local building codes for the appropriate state as indicated on these drawings. Refer to wall bracing notes in plan set for more information. Sheathing shall be applied with the long direction perpendicular to framing, unless noted otherwise.
4. Roof sheathing shall be APA rated sheathing exposure 1 or 2. Roof sheathing shall be continuous over two supports and attached to its supporting roof framing with (1)-8d CC nail at 6" o/c at panel edges and at 12" o/c in panel field unless otherwise noted on the plans. Sheathing shall be applied with the long direction perpendicular to framing. Sheathing shall have a span rating consistent with the framing spacing. Use suitable edge support by use of plywood clips or lumber blocking unless otherwise noted. Panel end joints shall occur over framing. Apply building paper over the sheathing as required by the state Building Code.
5. Wood floor sheathing shall be APA rated sheathing exposure 1 or 2. Attach sheathing to its supporting framing with (1)-8d CC ringshank nail at 6" o/c at panel edges and at 12" o/c in panel field unless otherwise noted on the plans. Sheathing shall be applied perpendicular to framing. Sheathing shall have a span rating consistent with the framing spacing. Use suitable edge support by use of T&G plywood or lumber blocking unless otherwise noted. Panel end joints shall occur over framing. Apply building paper over the sheathing as required by the state Building Code.
6. Sheathing shall have a 1/8" gap at panel ends and edges as recommended in accordance with the APA.

STRUCTURAL FIBERBOARD PANELS:

- 1. Fabrication and placement of structural fiberboard sheathing shall be in accordance with the applicable AFA standards.
2. All structurally required fiberboard sheathing shall bear the mark of the AFA.
3. Fiberboard wall sheathing shall comply with the requirements of local building codes for the appropriate state as indicated on these drawings. Refer to wall bracing notes in plan set for more information.
4. Sheathing shall have a 1/8" gap at panel ends and edges as recommended in accordance with the AFA.

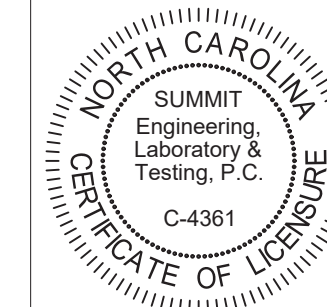

CLIENT: McKee Homes
109 Hay St., Suite 301
Fayetteville, NC 28301

PROJECT: Brooks II RH
Coversheet

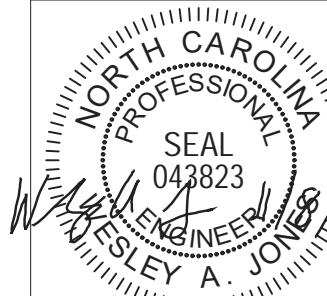

STRUCTURAL MEMBERS ONLY

DRAWING DATE: 10/08/2019
SCALE: 2/324 1/4" = 1'-0"
PROJECT # 043823
DRAWN BY: EPB
CHECKED BY: WAJ

ORIGINAL INFORMATION
PROJECT # 22336
DATE 09/03/2019

REFER TO COVER SHEET FOR A COMPLETE LIST OF REVISIONS

SHEET

CSI

FOUNDATION NOTES:

- FOUNDATIONS TO BE CONSTRUCTED IN ACCORDANCE WITH CHAPTER 4 OF THE 2018 NORTH CAROLINA RESIDENTIAL BUILDING CODE WITH ALL LOCAL AMENDMENTS.
- STRUCTURAL CONCRETE TO BE $F_c = 3000$ PSI, PREPARED AND PLACED IN ACCORDANCE WITH ACI STANDARD 318.
- FOOTINGS TO BE PLACED ON UNDISTURBED EARTH BEARING A MINIMUM OF 12" BELOW ADJACENT FINISHED GRADE, OR AS OTHERWISE DIRECTED BY THE CODE ENFORCEMENT OFFICIAL.
- FOOTING SIZES BASED ON A PRESUMPTIVE SOIL BEARING CAPACITY OF 2000 PSF. CONTRACTOR IS SOLELY RESPONSIBLE FOR VERIFYING THE SUITABILITY OF THE SITE SOIL CONDITIONS AT THE TIME OF CONSTRUCTION. FOOTINGS AND PIERS SHALL BE CENTERED UNDER THEIR RESPECTIVE ELEMENTS, PROVIDE 2" MINIMUM FOOTING PROJECTION FROM THE FACE OF MASONRY.
- MAXIMUM DEPTH OF UNBALANCED FILL AGAINST MASONRY WALLS TO BE AS SPECIFIED IN SECTION R404.1 OF THE 2018 NORTH CAROLINA RESIDENTIAL BUILDING CODE.
- FILASTERS TO BE BONDED TO PERIMETER FOUNDATION WALL.
- PROVIDE FOUNDATION WATERPROOFING, AND DRAIN WITH POSITIVE SLOPE TO OUTLET AS REQUIRED BY SITE CONDITIONS.
- PROVIDED PERIMETER INSULATION FOR ALL FOUNDATIONS PER 2018 NORTH CAROLINA RESIDENTIAL BUILDING CODE.
- CORBEL FOUNDATION WALL AS REQUIRED TO ACCOMMODATE BRICK VENEERS.
- CRAWL SPACE TO BE GRADED LEVEL, AND CLEARED OF ALL DEBRIS.
- FOUNDATION ANCHORAGE SHALL BE CONSTRUCTED PER THE 2018 NORTH CAROLINA RESIDENTIAL CODE SECTION R403.16. MINIMUM 1/2" DIA. BOLTS SPACED AT 6'-0" ON CENTER WITH A 1" MINIMUM EMBEDMENT INTO MASONRY OR CONCRETE. ANCHOR BOLTS SHALL BE 12" FROM THE END OF EACH PLATE SECTION. MINIMUM (2) ANCHOR BOLTS PER PLATE SECTION. ANCHOR BOLTS SHALL BE LOCATED IN THE CENTER THIRD OF THE PLATE.
- ABBREVIATIONS:
 DJ = DOUBLE JOIST SJ = SINGLE JOIST
 GT = GIRDER TRUSS FT = FLOOR TRUSS
 9C = STUD COLUMN DR = DOUBLE RAFTER
 EE = EACH END TR = TRIPLE RAFTER
 TJ = TRIPLE JOIST OC = ON CENTER
 CL = CENTER LINE PL = POINT LOAD
- ALL PIERS TO BE 16"x16" MASONRY AND ALL FILASTERS TO BE 8"x16" MASONRY, TYPICAL (UNO).
- WALL FOOTINGS TO BE CONTINUOUS CONCRETE, SIZES PER STRUCTURAL PLAN.
- A FOUNDATION EXCAVATION OBSERVATION SHOULD BE CONDUCTED BY A PROFESSIONAL GEOTECHNICAL ENGINEER OR HIS QUALIFIED REPRESENTATIVE. IF ISOLATED AREAS OF YIELDING MATERIALS AND/OR POTENTIALLY EXPANSIVE SOILS ARE OBSERVED IN THE FOOTING EXCAVATIONS AT THE TIME OF CONSTRUCTION, SUMMIT ENGINEERING, LABORATORY & TESTING, P.C. MUST BE PROVIDED THE OPPORTUNITY TO REVIEW THE FOOTING DESIGN PRIOR TO CONCRETE PLACEMENT.
- ALL FOOTINGS & SLABS ARE TO BEAR ON UNDISTURBED SOIL OR 95% COMPACTED FILL, VERIFIED BY ENGINEER OR CODE OFFICIAL.

REFER TO BRACED WALL PLAN FOR PANEL LOCATIONS AND ANY REQUIRED HOLD-DOWNS. ADDITIONAL INFORMATION PER SECTION R602.10.4 AND FIGURE R602.10.3(4) OF THE 2018 NCRC.

NOTE: ALL EXTERIOR FOUNDATION DIMENSIONS ARE TO FRAMING AND NOT BRICK VENEER, UNO

NOTE: A 4" CRUSHED STONE BASE COURSE IS NOT REQUIRED WHEN SLAB IS INSTALLED ON WELL-DRAINED OR SAND-GRAVEL MIXTURE SOILS CLASSIFIED AS GROUP 1 PER TABLE R405.1

REINFORCE GARAGE PORTAL WALLS PER FIGURE R602.10.4.3 OF THE 2018 NCRC. (TYP)

BEAM POCKETS MAY BE SUBSTITUTED FOR MASONRY FILASTERS AT GIRDER ENDS. BEAM POCKETS SHALL HAVE A MINIMUM 4" SOLID MASONRY BEARING.

NOTE: REDUCE JOIST SPACING UNDER TILE FLOORS, GRANITE COUNTERTOPS AND/OR ISLANDS.

DECK JOISTS SHALL BE SPACED AT A MAX. 12" O.C. WHEN DECK BOARDS ARE INSTALLED DIAGONALLY.

THESE PLANS ARE DESIGNED IN ACCORDANCE WITH ARCHITECTURAL PLANS PROVIDED BY MCKEE HOMES COMPLETED/REVISED ON 04/23/2019. IT IS THE RESPONSIBILITY OF THE CLIENT TO NOTIFY SUMMIT ENGINEERING, LABORATORY & TESTING, P.C. IF ANY CHANGES ARE MADE TO THE ARCHITECTURAL PLANS PRIOR TO CONSTRUCTION. SUMMIT ENGINEERING, LABORATORY & TESTING, P.C. CANNOT GUARANTEE THE ADEQUACY OF THESE STRUCTURAL PLANS WHEN USED WITH ARCHITECTURAL PLANS DATED DIFFERENTLY THAN THE DATE LISTED ABOVE.

STRUCTURAL MEMBERS ONLY

ENGINEERING SEAL APPLIES ONLY TO STRUCTURAL COMPONENTS ON THIS DOCUMENT. SEAL DOES NOT INCLUDE CONSTRUCTION MEANS, METHODS, TECHNIQUES, SEQUENCES, PROCEDURES OR SAFETY PRECAUTIONS. ANY DEVIATIONS OR DISCREPANCIES ON PLANS ARE TO BE BROUGHT TO THE IMMEDIATE ATTENTION OF SUMMIT ENGINEERING, LABORATORY & TESTING, P.C. FAILURE TO DO SO WILL VOID SUMMIT LIABILITY.

STRUCTURAL ANALYSIS BASED ON 2018 NCRC.

CRAWL SPACE FOUNDATION PLAN

SCALE: 1/4"=1'-0" OR 22"x34" OR 1/8"=1'-0" ON 11"x17"

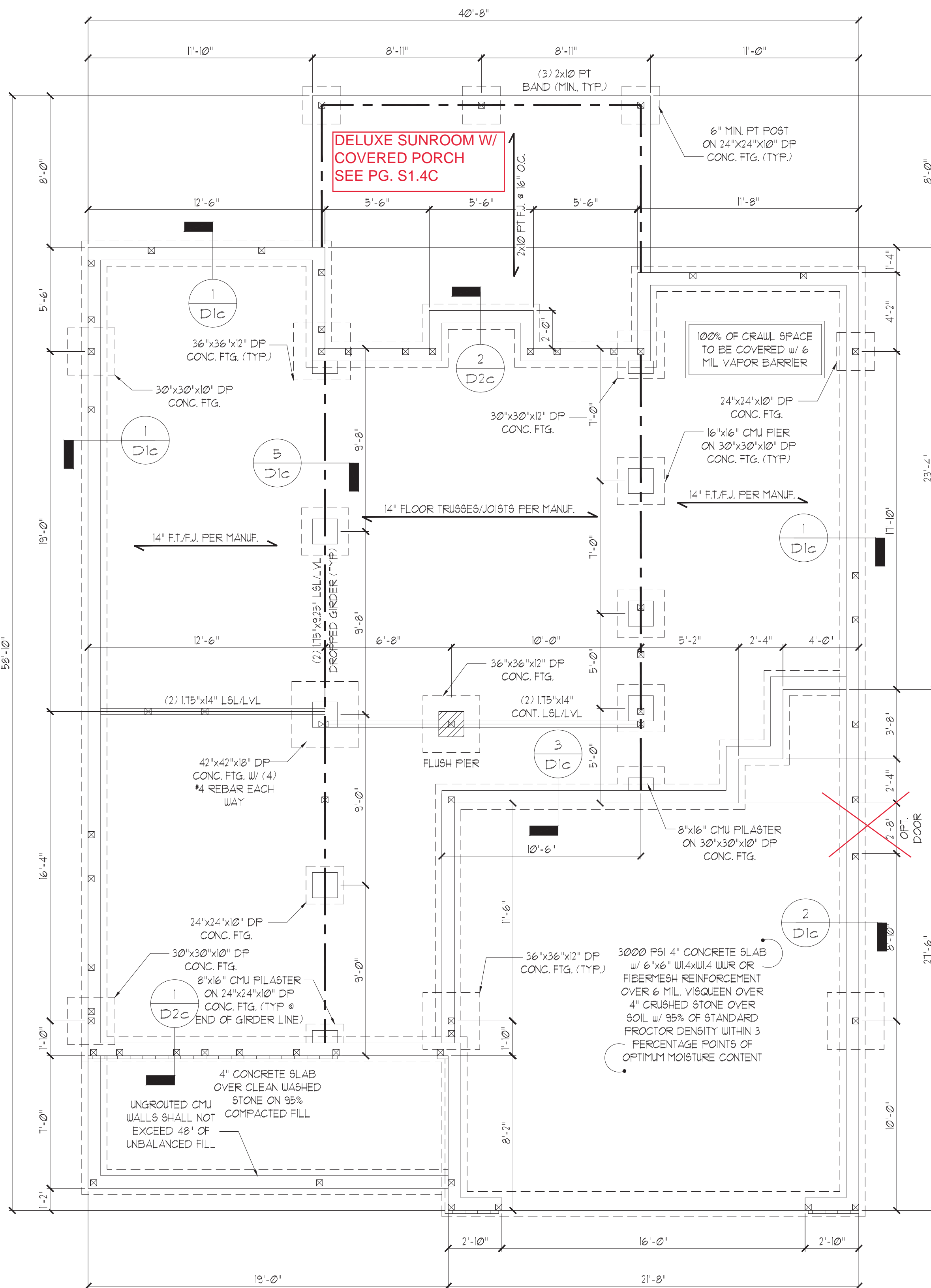

18"x24" MIN. CRAWL SPACE ACCESS DOOR TO BE LOCATED IN FIELD PER BUILDER. PROVIDE MIN. (2) 2x10 HEADER OVER DOOR w/ MIN. 4" BEARING EACH END. AVOID SHOWN POINT LOADS.

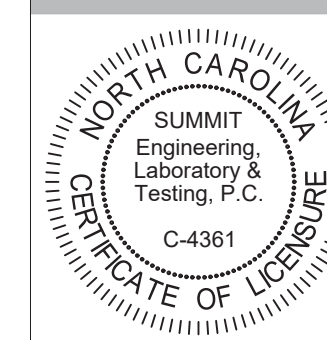

CLIENT:
 McKee Homes
 109 Hwy 61, Suite 301
 Fayetteville, NC 28301

PROJECT:
 Brooks II RH
 Crawl Space Foundation

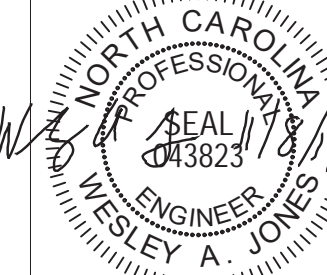

STRUCTURAL MEMBERS ONLY

DRAWING
 DATE: 11/08/2019
 SCALE: 22x34 1/4"=1'-0"
 1/8"=1'-0"
 PROJECT #: 22336R4
 DRAWN BY: EPB
 CHECKED BY: WAJ

ORIGINAL INFORMATION
 PROJECT #: 22336
 DATE: 09/03/2019
 REFER TO COVER SHEET FOR A COMPLETE LIST OF REVISIONS

SHEET

513c

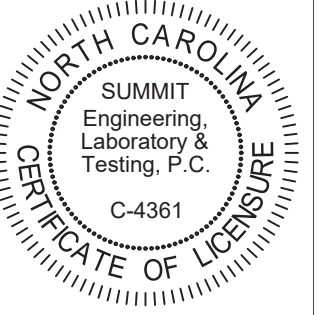

CLIENT:
 McKee Homes
 109 Hwy 51, Suite 301
 Fayetteville, NC 28301

PROJECT:
 Brooks II RH
 Crawl Space Foundation



STRUCTURAL MEMBERS ONLY

DRAWING
 DATE: 11/05/09
 SCALE: 22x4 1/4"=1'-0"
 1/8"=1'-0"
 PROJECT # 22336R4
 DRAWN BY: EPB
 CHECKED BY: WAJ

ORIGINAL INFORMATION
 PROJECT # 22336R4 DATE 05/03/09
 REFER TO COVER SHEET FOR A COMPLETE LIST OF REVISIONS

SHEET
 51.4c

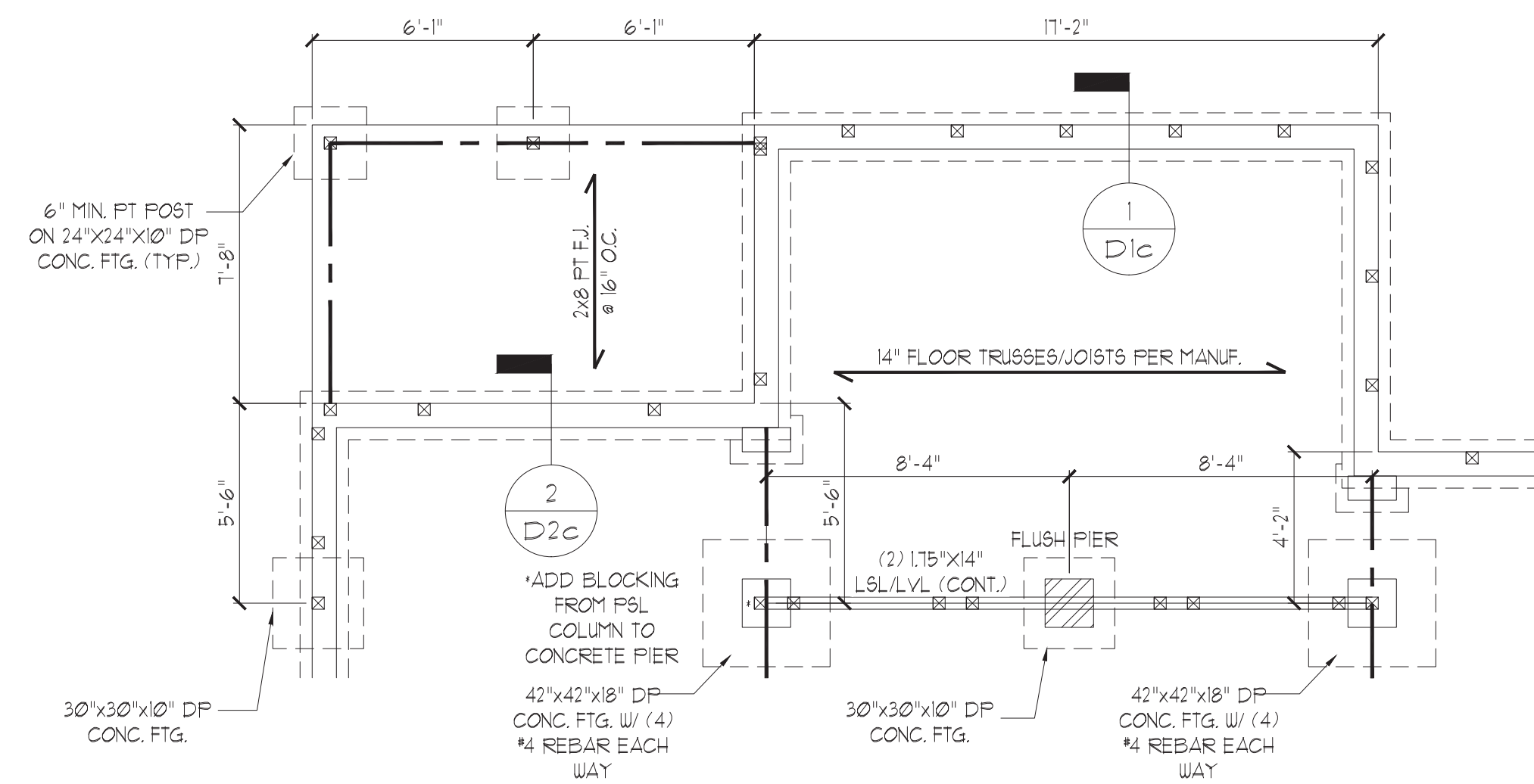

OPT. DELUXE SUNROOM
 W/ COVERED PORCH

STRUCTURAL MEMBERS ONLY

ENGINEERING SEAL APPLIES ONLY TO STRUCTURAL COMPONENTS ON THIS DOCUMENT. SEAL DOES NOT INCLUDE CONSTRUCTION MEANS, METHODS, TECHNIQUES, SEQUENCES, PROCEDURES OR SAFETY PRECAUTIONS. ANY DEVIATIONS OR DISCREPANCIES ON PLANS ARE TO BE BROUGHT TO THE IMMEDIATE ATTENTION OF SUMMIT ENGINEERING, LABORATORY & TESTING, P.C. FAILURE TO DO SO WILL VOID SUMMIT LIABILITY.

STRUCTURAL ANALYSIS BASED ON 2018 NCRC.

CRAWL SPACE FOUNDATION PLAN

SCALE: 1/4"=1'-0" ON 22"x34" OR 1/8"=1'-0" ON 11"x11"

GENERAL STRUCTURAL NOTES:

- CONSTRUCTION SHALL CONFORM TO 2018 NORTH CAROLINA RESIDENTIAL BUILDING CODE WITH ALL LOCAL AMENDMENTS.
- CONTRACTOR SHALL VERIFY ALL DIMENSIONS. CONTRACTOR SHALL COMPLY WITH THE CONTENTS OF THE DRAWING FOR THIS SPECIFIC PROJECT. ENGINEER IS NOT RESPONSIBLE FOR ANY DEVIATIONS FROM THIS PLAN.
- CONTRACTOR IS RESPONSIBLE FOR PROVIDING TEMPORARY BRACING REQUIRED TO RESIST ALL FORCES ENCOUNTERED DURING ERECTION. PROPERTIES USED IN THE DESIGN ARE AS FOLLOWS:
MICROLLAM (LVL): $F_b = 2600$ PSI, $F_v = 285$ PSI, $E = 13 \times 10^6$ PSI
PARALLAM (PSL): $F_b = 2900$ PSI, $F_v = 290$ PSI, $E = 125 \times 10^6$ PSI
- ALL WOOD MEMBERS SHALL BE #2 SYP UNLESS NOTED ON PLAN. ALL STUD COLUMNS AND JOISTS SHALL BE #2 SYP (UNO).
- ALL BEAMS SHALL BE SUPPORTED WITH A (2) 2x4 #2 SYP STUD COLUMN AT EACH END UNLESS NOTED OTHERWISE.
- ALL REINFORCING STEEL SHALL BE GRADE 60 BARS CONFORMING TO ASTM A615 AND SHALL HAVE A MINIMUM COVER OF 3".
- FOUNDATION ANCHORAGE SHALL BE CONSTRUCTED PER THE 2018 NORTH CAROLINA RESIDENTIAL CODE SECTION R403.1.6. MINIMUM 1/2" DIA. BOLTS SPACED AT 6'-0" ON CENTER WITH A 1" MINIMUM EMBEDMENT INTO MASONRY OR CONCRETE. ANCHOR BOLTS SHALL BE 12" FROM THE END OF EACH PLATE SECTION. MINIMUM (2) ANCHOR BOLTS PER PLATE SECTION. ANCHOR BOLTS SHALL BE LOCATED IN THE CENTER THIRD OF THE PLATE.
- CONTRACTOR TO PROVIDED LOOKOUTS WHEN CEILING JOISTS SPAN PERPENDICULAR TO RAFTERS.
- FLITCH BEAMS 4-PLY LVL5 AND 3-PLY SIDE LOADED LVL5 SHALL BE BOLTED TOGETHER WITH 1/2" DIA. THRU BOLTS SPACED AT 24" O.C. (MAX) STAGGERED OR EQUIVALENT CONNECTIONS PER DETAIL 1/D31. MIN. EDGE DISTANCE SHALL BE 2" AND (2) BOLTS SHALL BE LOCATED MINIMUM 6" FROM EACH END OF THE BEAM.
- ALL NON-LOAD BEARING HEADERS SHALL BE (1) FLAT 2x4 SYP #2, DROPPED. FOR NON-LOAD BEARING HEADERS EXCEEDING 8'-0" IN WIDTH AND/OR WITH MORE THAN 2'-0" OF CRIPPLE WALL ABOVE, SHALL BE (2) FLAT 2x4 SYP #2, DROPPED. (UNLESS NOTED OTHERWISE)
- ABBREVIATIONS:

DJ = DOUBLE JOIST SJ = SINGLE JOIST
GT = GIRDER TRUSS FT = FLOOR TRUSS
SC = STUD COLUMN DR = DOUBLE RAFTER
EE = EACH END TR = TRIPLE RAFTER
TJ = TRIPLE JOIST OC = ON CENTER
CL = CENTER LINE PL = POINT LOAD

SHADED WALLS INDICATED LOAD BEARING WALLS

NOTE: REDUCE JOIST SPACING UNDER TILE FLOORS, GRANITE COUNTERTOPS AND/OR ISLANDS.

JOIST 4 BEAM SIZES SHOWN ARE MINIMUMS. BUILDER MAY INCREASE DEPTH FOR EASE OF CONSTRUCTION.

NOTE:
--- DESIGNATES JOIST SUPPORTED LOAD BEARING WALL ABOVE. PROVIDE BLOCKING UNDER JOIST SUPPORTED LOAD BEARING WALL.

THESE PLANS ARE DESIGNED IN ACCORDANCE WITH ARCHITECTURAL PLANS PROVIDED BY MCKEE HOMES COMPLETED/REVISED ON 04/23/2019. IT IS THE RESPONSIBILITY OF THE CLIENT TO NOTIFY SUMMIT ENGINEERING LABORATORY & TESTING, P.C. IF ANY CHANGES ARE MADE TO THE ARCHITECTURAL PLANS PRIOR TO CONSTRUCTION. SUMMIT ENGINEERING LABORATORY & TESTING, P.C. CANNOT GUARANTEE THE ADEQUACY OF THESE STRUCTURAL PLANS WHEN USED WITH ARCHITECTURAL PLANS DATED DIFFERENTLY THAN THE DATE LISTED ABOVE.

STRUCTURAL MEMBERS ONLY

ENGINEERING SEAL APPLIES ONLY TO STRUCTURAL COMPONENTS ON THIS DOCUMENT. SEAL DOES NOT INCLUDE CONSTRUCTION MEANS, METHODS, TECHNIQUES, SEQUENCES, PROCEDURES OR SAFETY PRECAUTIONS. ANY DEVIATIONS OR DISCREPANCIES ON PLANS ARE TO BE BROUGHT TO THE IMMEDIATE ATTENTION OF SUMMIT ENGINEERING, LABORATORY & TESTING, P.C. FAILURE TO DO SO WILL VOID SUMMIT LIABILITY.

STRUCTURAL ANALYSIS BASED ON 2018 NCR. C.

FIRST FLOOR FRAMING PLAN

SCALE: 1/4"=1'-0" ON 22'x34" OR 1/8"=1'-0" ON 11'x11"

MIN. 4" FT. POSTS OR COL. RATED FOR 2100# (MIN. TYP.) ATTACH POSTS TO HEADER w/ 5/8" C616 STRIPS OR (4) 16d NAILS AND ATTACH POSTS TO FOUNDATION w/ 5/8" ABA44 POST BASE OR EQUIV. (TYP.)

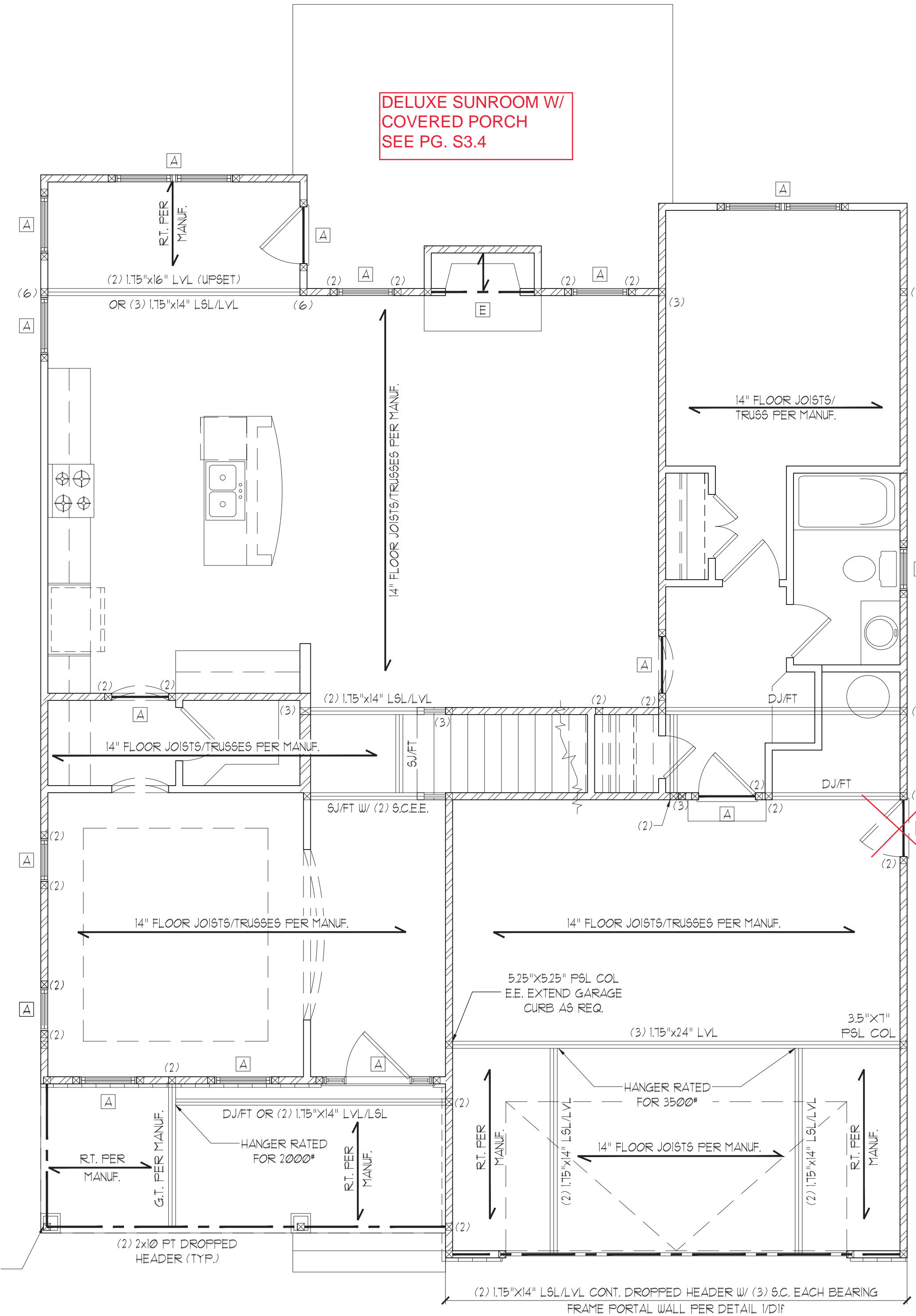

EURO

HEADER SCHEDULE

TAG	SIZE	JACKS (EACH END)
A	(2) 2x6	(1)
B	(2) 2x8	(2)
C	(2) 2x10	(2)
D	(2) 2x12	(2)
E	(2) 9-1/4" LSL/LVL	(3)
F	(3) 2x6	(1)
G	(3) 2x8	(2)
H	(3) 2x10	(2)
I	(3) 2x12	(3)

- NOTES:
- HEADER SIZES SHOWN ON PLANS ARE MINIMUMS. GREATER HEADER SIZES MAY BE USED FOR EASE OF CONSTRUCTION.
 - ALL HEADERS TO BE DROPPED (UNO).
 - STUD COLUMNS NOTED ON PLAN OVERRIDE STUD COLUMNS LISTED ABOVE (UNO).
 - OPENINGS LESS THAN 3'-0" USE (1) KING STUD AT E.E. OPENINGS 3'-1" TO 4'-0" USE (2) KING STUDS AT E.E. OPENINGS 4'-1" TO 8'-0" USE (3) KING STUDS AT E.E. OPENINGS 8'-1" TO 12'-0" USE (5) KING STUDS AT E.E. OPENINGS 12'-1" TO 16'-0" USE (6) KING STUDS AT E.E.

ALL HEADERS WHERE BRICK IS USED, TO BE:

- ① LINTEL (UNO.)

LINTEL SCHEDULE:

STEEL ANGLES TO HAVE MINIMUM 4" BEARING ONTO BRICK AT EACH END.

- L3x3x1/4"
- L5x3x1/4"
- L5x3-1/2x5/16"
- L5x3-1/2x5/16" ROLLED OR EQUAL ARCHED COMPONENT.

SECURE LINTEL TO HEADER w/ (2) 1/2" DIAMETER LAG SCREWS STAGGERED @ 16" O.C. (TYP FOR ③)

WALL STUD SCHEDULE (10 FT HEIGHT)

STUD SIZE	STUD SPACING (O.C.)			
	ROOF ONLY	ROOF & 1 FLOOR	ROOF & 2 FLOORS	NON-LOAD BEARING
2x4	24"	16"	12"	24"
2x6	24"	24"	16"	24"

- NOTES:
- BRACED WALLS STUDS SHALL BE A MAX. OF 16" O.C.
 - STUDS SUPPORTS OPTIONAL WALK-UP ATTIC SHALL BE SPACED A MAX. OF 16" O.C.
 - TWO STORY WALLS SHALL BE FRAMED w/ 2x4 STUDS @ 12" O.C. OR 2x6 STUDS @ 16" O.C. BALLOON FRAMED w/ CROSS BRACING @ 6'-0" O.C. VERTICALLY.

STRUCTURAL MEMBERS ONLY

DRAWING
DATE: 11/08/2019
SCALE: 22x34 1/4"=1'-0"
11x11 1/8"=1'-0"
PROJECT #: 22336R4
DRAWN BY: EPB
CHECKED BY: WJA

ORIGINAL INFORMATION
PROJECT #: 22336
DATE: 09/03/2019

REFER TO COVER SHEET FOR A COMPLETE LIST OF REVISIONS

SHEET

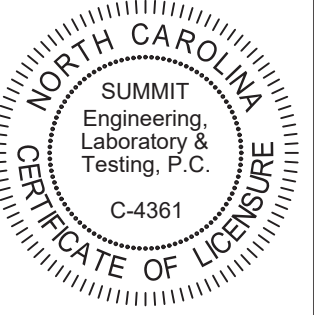

CLIENT:
McKee Homes
109 Hwy 51, Suite 301
Fayetteville, NC 28301

PROJECT:
Brooks II RH
First Floor Framing Plan



STRUCTURAL MEMBERS ONLY

DRAWING
DATE: 11/05/09
SCALE: 22x4 1/4"=1'-0"
1/8"=1'-0"
PROJECT # 22336R4
DRAWN BY: EPB
CHECKED BY: UAJ

ORIGINAL INFORMATION
PROJECT # 22336
DATE 05/03/09
REFER TO COVER SHEET FOR A COMPLETE LIST OF REVISIONS

SHEET
53.4

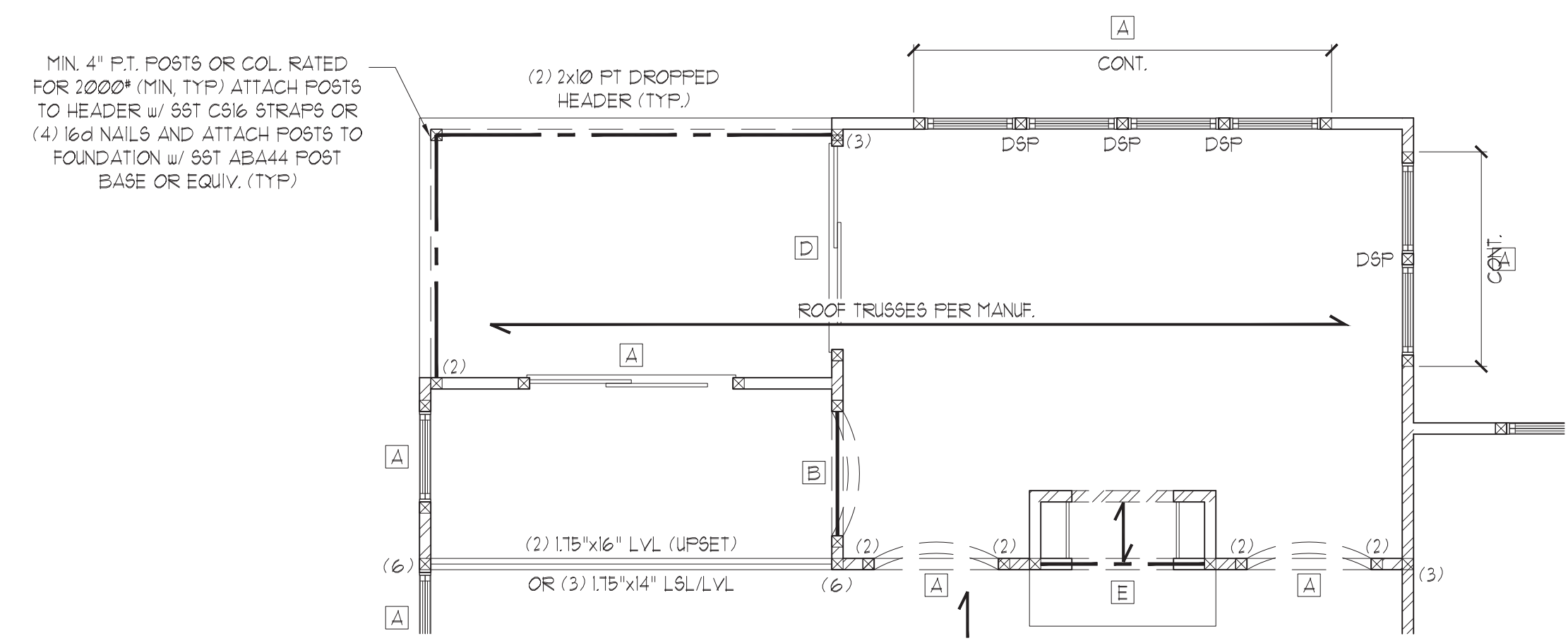

OPT. DELUXE SUNROOM
W/ COVERED PORCH

STRUCTURAL MEMBERS ONLY

ENGINEERING SEAL APPLIES ONLY TO STRUCTURAL COMPONENTS ON THIS DOCUMENT. SEAL DOES NOT INCLUDE CONSTRUCTION MEANS, METHODS, TECHNIQUES, SEQUENCES, PROCEDURES OR SAFETY PRECAUTIONS. ANY DEVIATIONS OR DISCREPANCIES ON PLANS ARE TO BE BROUGHT TO THE IMMEDIATE ATTENTION OF SUMMIT ENGINEERING, LABORATORY & TESTING, P.C. FAILURE TO DO SO WILL VOID SUMMIT LIABILITY.

STRUCTURAL ANALYSIS BASED ON 2018 NCRC.

FIRST FLOOR FRAMING PLAN

SCALE: 1/4"=1'-0" ON 22'x34" OR 1/8"=1'-0" ON 11'x11"

HEADER SCHEDULE		
TAG	SIZE	JACKS (EACH END)
A	(2) 2x6	(1)
B	(2) 2x8	(2)
C	(2) 2x10	(2)
D	(2) 2x12	(2)
E	(2) 3-1/4" LSL/LVL	(3)
F	(3) 2x6	(1)
G	(3) 2x8	(2)
H	(3) 2x10	(2)
I	(3) 2x12	(3)

NOTES:
 1. HEADER SIZES SHOWN ON PLANS ARE MINIMUMS. GREATER HEADER SIZES MAY BE USED FOR EASE OF CONSTRUCTION.
 2. ALL HEADERS TO BE DROPPED (UNO).
 3. STUD COLUMNS NOTED ON PLAN OVERRIDE STUD COLUMNS LISTED ABOVE (UNO).
 4. OPENINGS LESS THAN 3'-0" USE (1) KING STUD AT E.E. OPENINGS 3'-1" TO 4'-0" USE (2) KING STUDS AT E.E. OPENINGS 4'-1" TO 8'-0" USE (3) KING STUDS AT E.E. OPENINGS 8'-1" TO 12'-0" USE (5) KING STUDS AT E.E. OPENINGS 12'-1" TO 16'-0" USE (6) KING STUDS AT E.E.

ALL HEADERS WHERE BRICK IS USED, TO BE:
 (1) LINTEL (UNO.)

LINTEL SCHEDULE:

STEEL ANGLES TO HAVE MINIMUM 4" BEARING ONTO BRICK AT EACH END.

(1) L3x3x1/4"
 (2) L5x3"x1/4"
 (3) L5x3-1/2x5/16"
 (4) L5x3-1/2"x5/16" ROLLED OR EQUAL ARCHED COMPONENT.

SECURE LINTEL TO HEADER w/ (2) 1/2" DIAMETER LAG SCREWS STAGGERED @ 16" O.C. (TYP FOR (3))

WALL STUD SCHEDULE (10 FT HEIGHT)				
STUD SIZE	STUD SPACING (O.C.)			
	ROOF ONLY	ROOF & 1 FLOOR	ROOF & 2 FLOORS	NON-LOAD BEARING
2x4	24"	16"	12"	24"
2x6	24"	24"	16"	24"

NOTES:
 1. BRACED WALLS STUDS SHALL BE A MAX. OF 16" O.C.
 2. STUDS SUPPORTS OPTIONAL WALK-UP ATTIC SHALL BE SPACED A MAX. OF 16" O.C.
 3. TWO STORY WALLS SHALL BE FRAMED w/ 2x4 STUDS @ 12" O.C. OR 2x6 STUDS @ 16" O.C. BALLOON FRAMED w/ CROSS BRACING @ 6'-0" O.C. VERTICALLY.

SHADED WALLS INDICATED LOAD BEARING WALLS

JOIST & BEAM SIZES SHOWN ARE MINIMUMS. BUILDER MAY INCREASE DEPTH FOR EASE OF CONSTRUCTION.

THESE PLANS ARE DESIGNED IN ACCORDANCE WITH ARCHITECTURAL PLANS PROVIDED BY MCKEE HOMES COMPLETED/REVISED ON 04/23/2019. IT IS THE RESPONSIBILITY OF THE CLIENT TO NOTIFY SUMMIT ENGINEERING LABORATORY & TESTING, P.C. IF ANY CHANGES ARE MADE TO THE ARCHITECTURAL PLANS PRIOR TO CONSTRUCTION. SUMMIT ENGINEERING LABORATORY & TESTING, P.C. CANNOT GUARANTEE THE ADEQUACY OF THESE STRUCTURAL PLANS WHEN USED WITH ARCHITECTURAL PLANS DATED DIFFERENTLY THAN THE DATE LISTED ABOVE.

STRUCTURAL MEMBERS ONLY

ENGINEERING SEAL APPLIES ONLY TO STRUCTURAL COMPONENTS ON THIS DOCUMENT. SEAL DOES NOT INCLUDE CONSTRUCTION MEANS, METHODS, TECHNIQUES, SEQUENCES, PROCEDURES OR SAFETY PRECAUTIONS. ANY DEVIATIONS OR DISCREPANCIES ON PLANS ARE TO BE BROUGHT TO THE IMMEDIATE ATTENTION OF SUMMIT ENGINEERING, LABORATORY & TESTING, P.C. FAILURE TO DO SO WILL VOID SUMMIT LIABILITY.

STRUCTURAL ANALYSIS BASED ON 2018 NCR. C.

SECOND FLOOR FRAMING PLAN

SCALE: 1/4"=1'-0" ON 22'x34" OR 1/8"=1'-0" ON 11'x11"

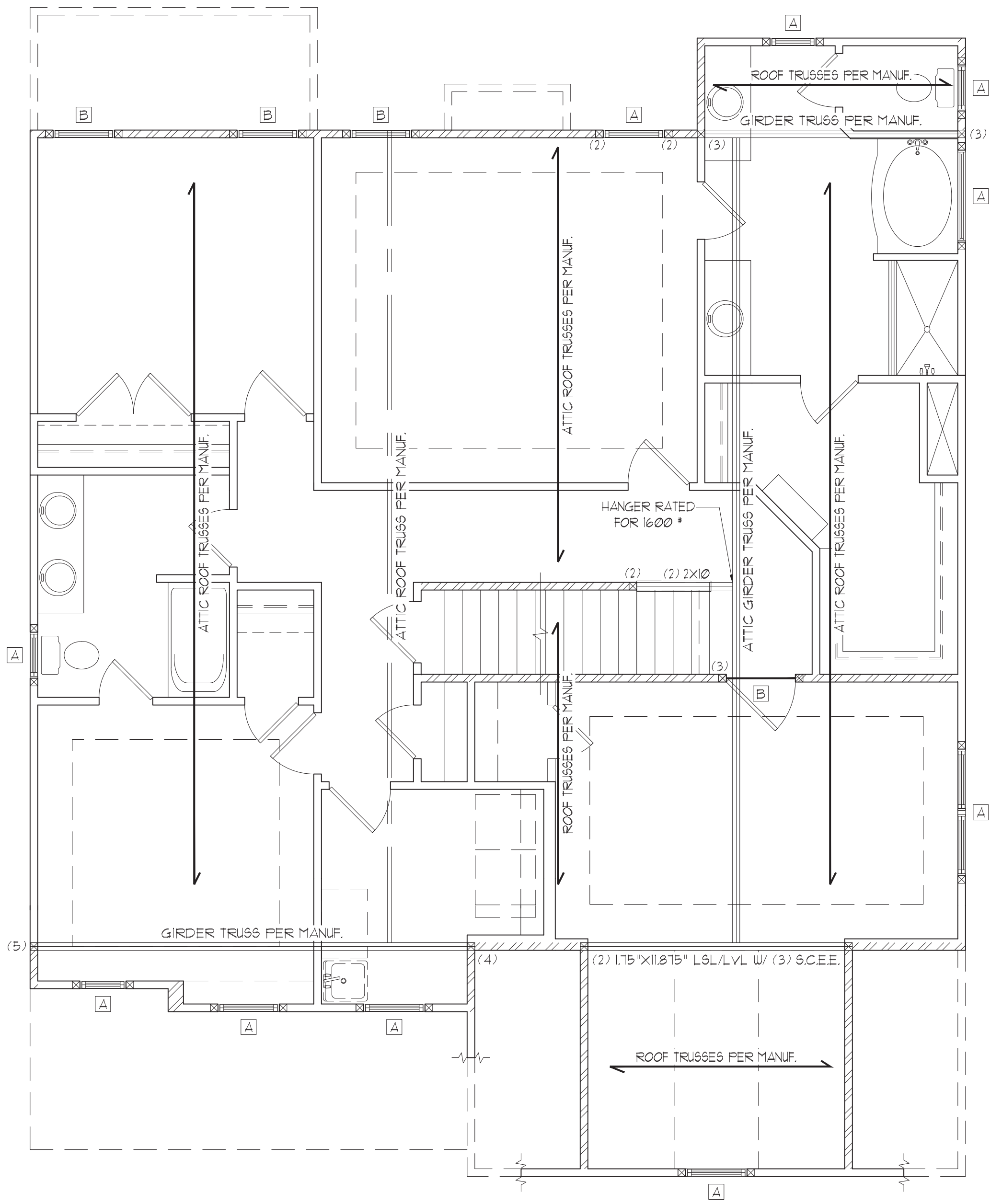

EURO

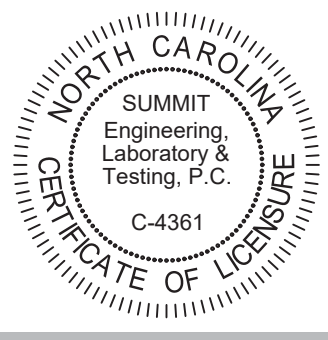

CLIENT:
 McKee Homes
 109 Hwy 61, Suite 301
 Fayetteville, NC 28301

PROJECT:
 Brooks II RH
 Second Floor Framing Plan



STRUCTURAL MEMBERS ONLY

DRAWING
 DATE: 11/08/2019
 SCALE: 22x34 1/4"=1'-0"
 11x11 1/8"=1'-0"
 PROJECT #: 22336R4
 DRAWN BY: EPB
 CHECKED BY: WAJ

ORIGINAL INFORMATION
 PROJECT #: 22336
 DATE: 09/03/2019

REFER TO COVER SHEET FOR A COMPLETE LIST OF REVISIONS

HEADER SCHEDULE		
TAG	SIZE	JACKS (EACH END)
A	(2) 2x6	(1)
B	(2) 2x8	(2)
C	(2) 2x10	(2)
D	(2) 2x12	(2)
E	(2) 9-1/4" LSL/LVL	(3)
F	(3) 2x6	(1)
G	(3) 2x8	(2)
H	(3) 2x10	(2)
I	(3) 2x12	(3)

NOTES:
 1. HEADER SIZES SHOWN ON PLANS ARE MINIMUMS. GREATER HEADER SIZES MAY BE USED FOR EASE OF CONSTRUCTION.
 2. ALL HEADERS TO BE DROPPED (UNO).
 3. STUD COLUMNS NOTED ON PLAN OVERRIDE STUD COLUMNS LISTED ABOVE (UNO).
 4. OPENINGS LESS THAN 3'-0" USE (1) KING STUD AT E.E.
 OPENINGS 3'-1" TO 4'-0" USE (2) KING STUDS AT E.E.
 OPENINGS 4'-1" TO 8'-0" USE (3) KING STUDS AT E.E.
 OPENINGS 8'-1" TO 12'-0" USE (5) KING STUDS AT E.E.
 OPENINGS 12'-1" TO 16'-0" USE (6) KING STUDS AT E.E.

ALL HEADERS WHERE BRICK IS USED, TO BE:
 ① LINTEL (UNO.)

LINTEL SCHEDULE:

STEEL ANGLES TO HAVE MINIMUM 4" BEARING ONTO BRICK AT EACH END.

① L3x3x1/4"
 ② L5x3x1/4"
 ③ L5x3-1/2x5/16"
 ④ L5x3-1/2"x5/16" ROLLED OR EQUAL ARCHED COMPONENT.

SECURE LINTEL TO HEADER w/ (2) 1/2" DIAMETER LAG SCREWS STAGGERED @ 16" O.C. (TYP FOR ③)

WALL STUD SCHEDULE (10 FT HEIGHT)				
STUD SIZE	STUD SPACING (O.C.)			
	ROOF ONLY	ROOF & 1 FLOOR	ROOF & 2 FLOORS	NON-LOAD BEARING
2x4	24"	16"	12"	24"
2x6	24"	24"	16"	24"

NOTES:
 1. BRACED WALLS STUDS SHALL BE A MAX. OF 16" O.C.
 2. STUDS SUPPORTS OPTIONAL WALK-UP ATTIC SHALL BE SPACED A MAX. OF 16" O.C.
 3. TWO STORY WALLS SHALL BE FRAMED w/ 2x4 STUDS @ 12" O.C. OR 2x6 STUDS @ 16" O.C. BALLOON FRAMED w/ CROSS BRACING @ 6'-0" O.C. VERTICALLY.

SHADED WALLS INDICATED LOAD BEARING WALLS

JOIST & BEAM SIZES SHOWN ARE MINIMUMS. BUILDER MAY INCREASE DEPTH FOR EASE OF CONSTRUCTION.

THESE PLANS ARE DESIGNED IN ACCORDANCE WITH ARCHITECTURAL PLANS PROVIDED BY MCKEE HOMES COMPLETED/REVISED ON 04/23/2019. IT IS THE RESPONSIBILITY OF THE CLIENT TO NOTIFY SUMMIT ENGINEERING, LABORATORY & TESTING, P.C. IF ANY CHANGES ARE MADE TO THE ARCHITECTURAL PLANS PRIOR TO CONSTRUCTION. SUMMIT ENGINEERING, LABORATORY & TESTING, P.C. CANNOT GUARANTEE THE ADEQUACY OF THESE STRUCTURAL PLANS WHEN USED WITH ARCHITECTURAL PLANS DATED DIFFERENTLY THAN THE DATE LISTED ABOVE.

STRUCTURAL MEMBERS ONLY

ENGINEERING SEAL APPLIES ONLY TO STRUCTURAL COMPONENTS ON THIS DOCUMENT. SEAL DOES NOT INCLUDE CONSTRUCTION MEANS, METHODS, TECHNIQUES, SEQUENCES, PROCEDURES OR SAFETY PRECAUTIONS. ANY DEVIATIONS OR DISCREPANCIES ON PLANS ARE TO BE BROUGHT TO THE IMMEDIATE ATTENTION OF SUMMIT ENGINEERING, LABORATORY & TESTING, P.C. FAILURE TO DO SO WILL VOID SUMMIT LIABILITY.

STRUCTURAL ANALYSIS BASED ON 2018 NCR.

WALK-UP ATTIC FRAMING PLAN

SCALE: 1/4"=1'-0" ON 22'x34" OR 1/8"=1'-0" ON 11'x11"

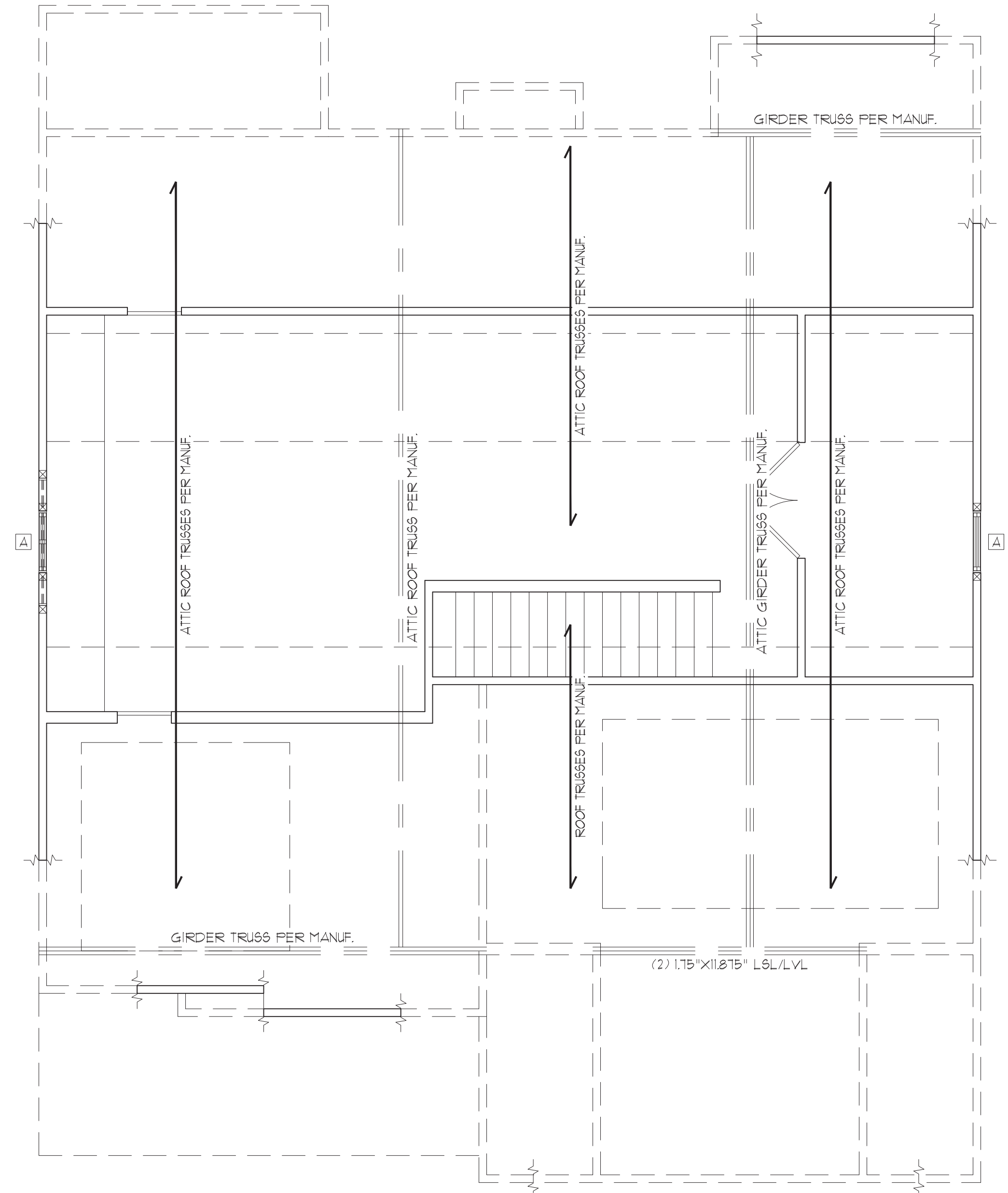

EURO

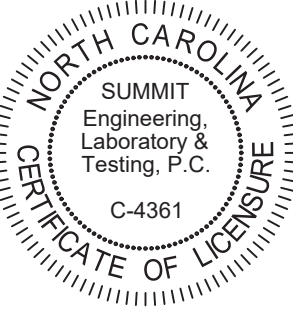

CLIENT:
 McKee Homes
 109 Hwy 61, Suite 201
 Fayetteville, NC 28301

PROJECT:
 Brooks II RH
 Walk-Up Attic Framing Plan



DATE: 11/05/2019
 SCALE: 22x34 1/4"=1'-0"
 1/8"=1'-0"
 PROJECT #: 22336R4
 DRAWN BY: EPB
 CHECKED BY: WAJ

REFER TO COVER SHEET FOR A COMPLETE LIST OF REVISIONS

SHEET

54.1

MAX. UPLIFT	ROOF TO WALL	FLOOR TO FLOOR	FLOOR TO END
600 LBS	H2.5A	PER WALL SHEATHING & FASTENERS	
1200 LBS	(2) H2.5A	C916 (END = 11")	DTT2Z
1450 LBS	HT520	C916 (END = 11")	DTT2Z
2000 LBS	(2) HT520	(2) C916 (END = 11")	DTT2Z
2300 LBS	(2) HT520	(2) C916 (END = 11")	HTT4
3685 LBS	LGT3-SD525	M5TC52	HTT4

- ALL PRODUCTS LISTED ARE SIMPSON STRONG-TIE. EQUIVALENT PRODUCTS MAY BE USED PER MANUFACTURER'S SPECIFICATIONS.
- UPLIFT VALUES LISTED ARE FOR SYP #2 GRADE MEMBERS.
- REFER TO TRUSS LAYOUT PER MANUF. FOR UPLIFT VALUES AND TRUSS TO TRUSS CONNECTIONS. CONNECTORS SPECIFIED BY TRUSS MANUFACTURER OVERRIDE THOSE LISTED ABOVE.
- CONTACT SUMMIT FOR REQUIRED CONNECTORS WHEN LOADS EXCEED THOSE LISTED ABOVE.

NOTE: 1ST FLY OF ALL SHOWN GIRDER TRUSSES TO ALIGN WITH INSIDE FACE OF WALL (TYP, UNO)

NOTE: ROOF TRUSSES SHALL BE SPACED TO SUPPORT FALSE FRAMED DORMER WALLS (TYP, UNO)

REFER TO DETAIL 5/D3F FOR EYEBROW, RETURN OR SHED ROOF FRAMING REQUIREMENTS. (TYP FOR ROOFS PROTRUDING MAXIMUM 24" FROM STRUCTURE)

NOTE: TRUSS UPLIFT LOADS SHALL BE DETERMINED PER TRUSS MANUFACTURER IN ACCORDANCE WITH SECTION R02.11.1. WALL SHEATHING AND FASTENERS HAVE BEEN DESIGNED TO RESIST THE WIND UPLIFT LOAD PATH IN ACCORDANCE WITH METHOD 3 OF SECTION R02.3.5 OF THE 2018 NCRC. REFER TO BRACED WALL PLANS FOR SHEATHING AND FASTENER REQUIREMENTS.

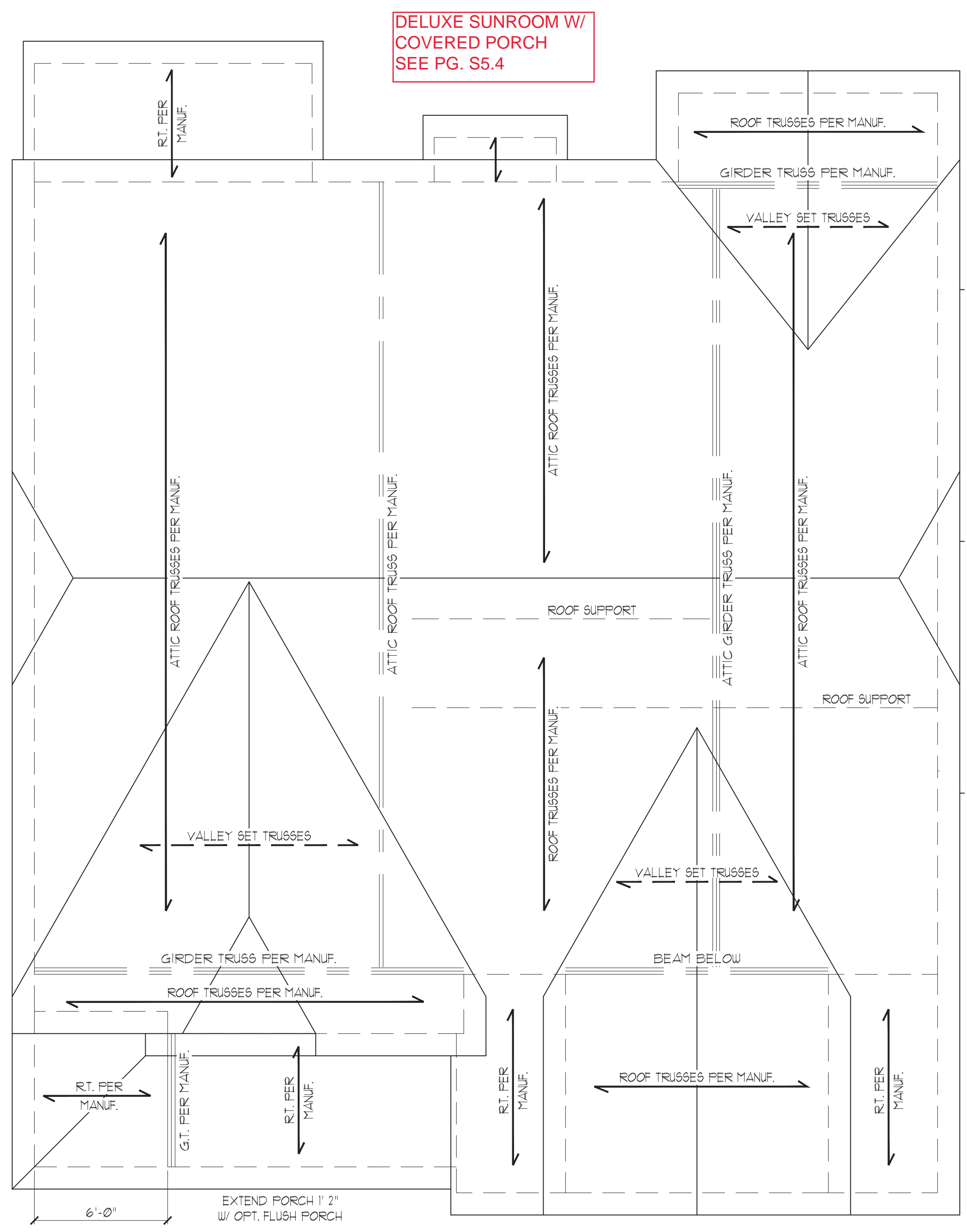

THESE PLANS ARE DESIGNED IN ACCORDANCE WITH ARCHITECTURAL PLANS PROVIDED BY MCKEE HOMES COMPLETED/REVISED ON 04/23/2019. IT IS THE RESPONSIBILITY OF THE CLIENT TO NOTIFY SUMMIT ENGINEERING LABORATORY & TESTING, P.C. IF ANY CHANGES ARE MADE TO THE ARCHITECTURAL PLANS PRIOR TO CONSTRUCTION. SUMMIT ENGINEERING LABORATORY & TESTING, P.C. CANNOT GUARANTEE THE ADEQUACY OF THESE STRUCTURAL PLANS WHEN USED WITH ARCHITECTURAL PLANS DATED DIFFERENTLY THAN THE DATE LISTED ABOVE.

STRUCTURAL MEMBERS ONLY

ENGINEERING SEAL APPLIES ONLY TO STRUCTURAL COMPONENTS ON THIS DOCUMENT. SEAL DOES NOT INCLUDE CONSTRUCTION MEANS, METHODS, TECHNIQUES, SEQUENCES, PROCEDURES OR SAFETY PRECAUTIONS. ANY DEVIATIONS OR DISCREPANCIES ON PLANS ARE TO BE BROUGHT TO THE IMMEDIATE ATTENTION OF SUMMIT ENGINEERING, LABORATORY & TESTING, P.C. FAILURE TO DO SO WILL VOID SUMMIT LIABILITY.

STRUCTURAL ANALYSIS BASED ON 2018 NCRC.

ROOF FRAMING PLAN

SCALE: 1/4"=1'-0" ON 22'x24' OR 1/8"=1'-0" ON 11'x11'

EURO

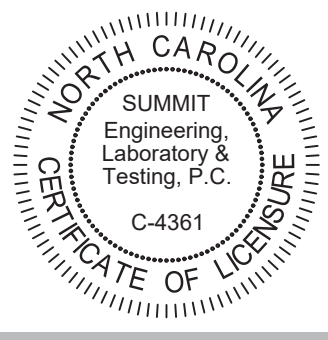

CLIENT:
McKee Homes
109 Hay St., Suite 201
Fayetteville, NC 28301

PROJECT:
Brooks II RH
Roof Framing Plan

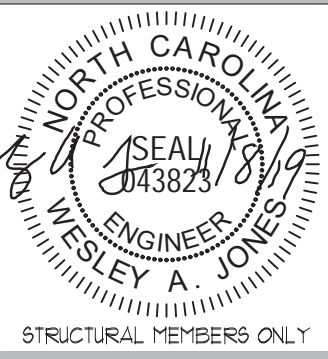

DRIVING
DATE: 11/08/2019
SCALE: 22x4 1/4"=1'-0"
1/8"=1'-0"
PROJECT # 22336R4
DRAWN BY: EPB
CHECKED BY: WAJ

ORIGINAL INFORMATION
PROJECT # 22336
DATE 09/03/2019
REFER TO COVER SHEET FOR A COMPLETE LIST OF REVISIONS

SHEET
S5.3

TRUSS UPLIFT CONNECTOR SCHEDULE			
MAX. UPLIFT	ROOF TO WALL	FLOOR TO FLOOR	FLOOR TO END
600 LBS	H2.5A	PER WALL SHEATHING & FASTENERS	
1200 LBS	(2) H2.5A	C916 (END = 11")	DTT2Z
1450 LBS	HT520	C916 (END = 11")	DTT2Z
2000 LBS	(2) HT520	(2) C916 (END = 11")	DTT2Z
2900 LBS	(2) HT520	(2) C916 (END = 11")	HTT4
3685 LBS	LGT3-SD525	M5TC52	HTT4

- ALL PRODUCTS LISTED ARE SIMPSON STRONG-TIE. EQUIVALENT PRODUCTS MAY BE USED PER MANUFACTURER'S SPECIFICATIONS.
- UPLIFT VALUES LISTED ARE FOR SYP #2 GRADE MEMBERS.
- REFER TO TRUSS LAYOUT PER MANUF. FOR UPLIFT VALUES AND TRUSS TO TRUSS CONNECTIONS. CONNECTORS SPECIFIED BY TRUSS MANUFACTURER OVERRIDE THOSE LISTED ABOVE.
- CONTACT SUMMIT FOR REQUIRED CONNECTORS WHEN LOADS EXCEED THOSE LISTED ABOVE.

NOTE: 1ST FLY OF ALL SHOWN GIRDER TRUSSES TO ALIGN WITH INSIDE FACE OF WALL (TYP, UNO)

NOTE: ROOF TRUSSES SHALL BE SPACED TO SUPPORT FALSE FRAMED DORMER WALLS (TYP, UNO)

REFER TO DETAIL 5/D3F FOR EYEBROW, RETURN OR SHED ROOF FRAMING REQUIREMENTS. (TYP FOR ROOFS PROTRUDING MAXIMUM 24" FROM STRUCTURE)

NOTE: TRUSS UPLIFT LOADS SHALL BE DETERMINED PER TRUSS MANUFACTURER IN ACCORDANCE WITH SECTION R002.III.I. WALL SHEATHING AND FASTENERS HAVE BEEN DESIGNED TO RESIST THE WIND UPLIFT LOAD PATH IN ACCORDANCE WITH METHOD 3 OF SECTION R002.3.5 OF THE 2018 NCRC. REFER TO BRACED WALL PLANS FOR SHEATHING AND FASTENER REQUIREMENTS.

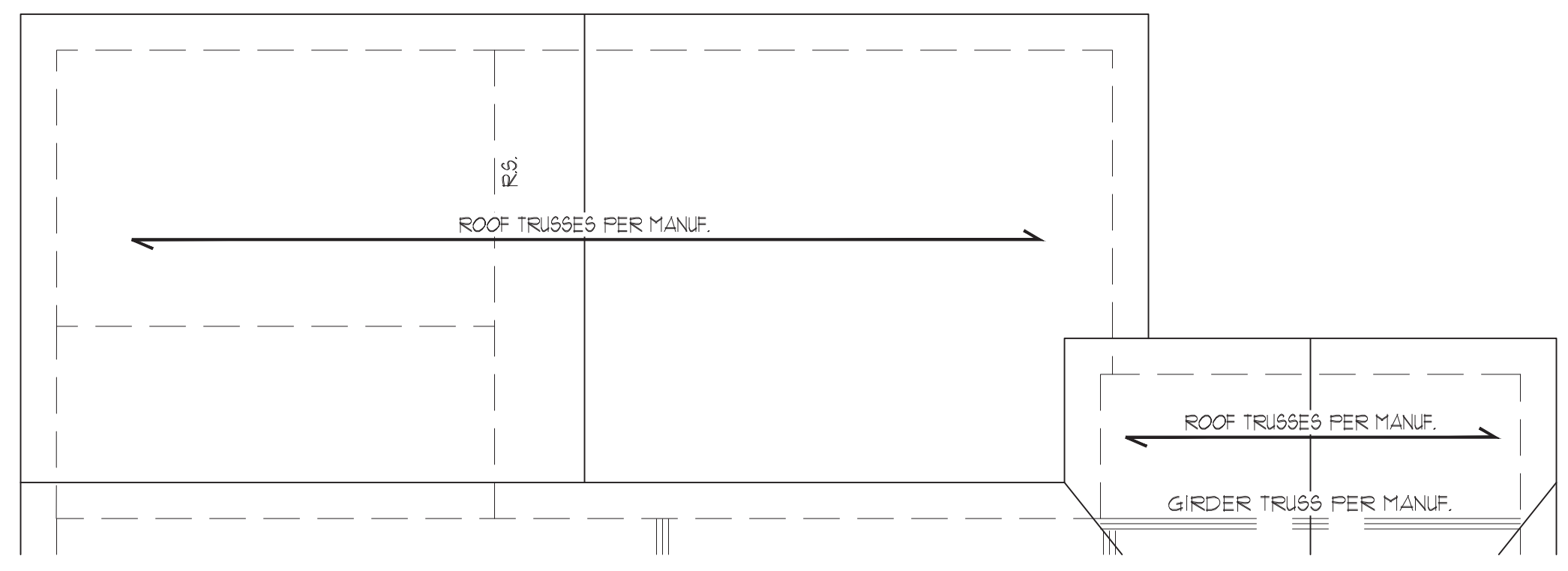

OPT. DELUXE SUNROOM
W/ COVERED PORCH

THESE PLANS ARE DESIGNED IN ACCORDANCE WITH ARCHITECTURAL PLANS PROVIDED BY MCKEE HOMES COMPLETED/REVISED ON 04/23/2019. IT IS THE RESPONSIBILITY OF THE CLIENT TO NOTIFY SUMMIT ENGINEERING LABORATORY & TESTING, P.C. IF ANY CHANGES ARE MADE TO THE ARCHITECTURAL PLANS PRIOR TO CONSTRUCTION. SUMMIT ENGINEERING LABORATORY & TESTING, P.C. CANNOT GUARANTEE THE ADEQUACY OF THESE STRUCTURAL PLANS WHEN USED WITH ARCHITECTURAL PLANS DATED DIFFERENTLY THAN THE DATE LISTED ABOVE.

STRUCTURAL MEMBERS ONLY

ENGINEERING SEAL APPLIES ONLY TO STRUCTURAL COMPONENTS ON THIS DOCUMENT. SEAL DOES NOT INCLUDE CONSTRUCTION MEANS, METHODS, TECHNIQUES, SEQUENCES, PROCEDURES OR SAFETY PRECAUTIONS. ANY DEVIATIONS OR DISCREPANCIES ON PLANS ARE TO BE BROUGHT TO THE IMMEDIATE ATTENTION OF SUMMIT ENGINEERING, LABORATORY & TESTING, P.C. FAILURE TO DO SO WILL VOID SUMMIT LIABILITY.

STRUCTURAL ANALYSIS BASED ON 2018 NCRC.

ROOF FRAMING PLAN

SCALE: 1/4"=1'-0" ON 22'x24" OR 1/8"=1'-0" ON 11'x11"

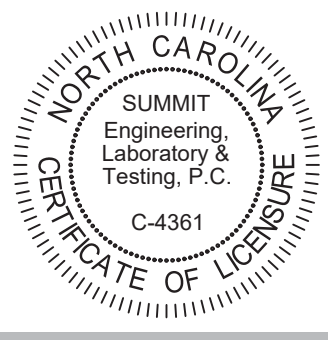

CLIENT:
McKee Homes
109 Hwy 51, Suite 301
Fayetteville, NC 28301

PROJECT:
Brooks II RH
Roof Framing Plan



STRUCTURAL MEMBERS ONLY

DRAWING
DATE: 11/05/2019
SCALE: 22x4 1/4"=1'-0"
1x11 1/8"=1'-0"
PROJECT #: 22336R4
DRAWN BY: EPB
CHECKED BY: UAJ

ORIGINAL INFORMATION
PROJECT # 22336 DATE 05/03/2019
REFER TO COVER SHEET FOR A COMPLETE LIST OF REVISIONS

SHEET
55.4

REQUIRED BRACED WALL PANEL CONNECTIONS				
METHOD	MATERIAL	MIN. THICKNESS	REQUIRED CONNECTION	
			# PANEL EDGES	# INTERMEDIATE SUPPORTS
CS-WSP	WOOD STRUCTURAL PANEL	3/8"	6d COMMON NAILS @ 6" O.C.	6d COMMON NAILS @ 12" O.C.
GB	GYP SUM BOARD	1/2"	5d COOLER NAILS** @ 1" O.C.	5d COOLER NAILS** @ 1" O.C.
WSP	WOOD STRUCTURAL PANEL	3/8"	6d COMMON NAILS @ 6" O.C.	6d COMMON NAILS @ 12" O.C.
FF	WOOD STRUCTURAL PANEL	7/16"	PER FIGURE R602.10.1	PER FIGURE R602.10.1

**OR EQUIVALENT PER TABLE R102.3.5

BRACED WALL NOTES:

- WALLS SHALL BE DESIGNED IN ACCORDANCE WITH SECTION R602.10 FROM THE 2018 INTERNATIONAL RESIDENTIAL CODE WITH ALL LOCAL AND STATE AMENDMENTS.
- WALLS ARE DESIGNED FOR SEISMIC ZONES A-C AND ULTIMATE DESIGN WIND SPEEDS UP TO 130 MPH.
- REFER TO ARCHITECTURAL PLAN FOR DOOR/WINDOW OPENING SIZES.
- BRACING MATERIALS, METHODS AND FASTENERS SHALL BE IN ACCORDANCE WITH TABLE R602.10.
- ALL BRACED WALL PANELS SHALL BE FULL WALL HEIGHT AND SHALL NOT EXCEED 10 FEET FOR ISOLATED PANEL METHOD AND 12 FEET FOR CONTINUOUS SHEATHING METHOD WITHOUT ADDITIONAL ENGINEERING CALCULATIONS.
- MINIMUM PANEL LENGTH SHALL BE PER TABLE R602.10.1.
- THE INTERIOR SIDE OF EXTERIOR WALLS AND BOTH SIDES OF INTERIOR WALLS SHALL BE SHEATHED CONTINUOUSLY WITH MINIMUM 1/2" GYPSUM BOARD (UNO).
- FOR CONTINUOUS SHEATHING METHOD, EXTERIOR WALLS SHALL BE SHEATHED ON ALL SHEATHABLE SURFACES INCLUDING INFILL AREAS BETWEEN BRACED WALL PANELS, ABOVE AND BELOW WALL OPENINGS, AND ON GABLE END WALLS.
- FLOORS SHALL NOT BE CANTILEVERED MORE THAN 24" BEYOND THE FOUNDATION OR BEARING WALL BELOW WITHOUT ADDITIONAL ENGINEERING CALCULATIONS.
- A BRACED WALL PANEL SHALL BE LOCATED WITHIN 12 FEET OF EACH END OF A BRACED WALL LINE.
- THE MAXIMUM EDGE DISTANCE BETWEEN BRACED WALL PANELS SHALL NOT EXCEED 21 FEET.
- MASONRY OR CONCRETE STEM WALLS WITH A LENGTH OF 40' OR LESS SUPPORTING A BRACED WALL PANEL SHALL BE DESIGNED IN ACCORDANCE WITH FIGURE R602.10.4.3 OF THE 2018 IRC OR DETAIL 2/D21.
- BRACED WALL PANEL CONNECTIONS TO FLOOR/CEILING SHALL BE CONSTRUCTED IN ACCORDANCE WITH SECTION R602.10.4.4.
- BRACED WALL PANEL CONNECTIONS TO ROOF SHALL BE CONSTRUCTED IN ACCORDANCE WITH SECTION R602.10.4.5.
- CRIPPLE WALLS AND WALK OUT BASEMENT WALLS SHALL BE DESIGNED IN ACCORDANCE WITH SECTION R602.10.4.6.
- PORTAL WALLS SHALL BE DESIGNED IN ACCORDANCE WITH FIGURE R602.10.1 (UNO).
- ON SCHEMATIC, SHADED WALLS INDICATE BRACED WALL PANELS.
- ABBREVIATIONS:

GB = GYPSUM BOARD WSP = WOOD STRUCTURAL PANEL
 CS-XXX = CONT. SHEATHED ENG = ENGINEERED SOLUTION
 FF = PORTAL FRAME FF-ENG = ENG. PORTAL FRAME

INSTALL HOLD-DOWNS FOR BRACED WALL END CONDITIONS PER SECTION R602.10.4 AND FIGURE R602.10.3(4) OF THE 2018 NCR.

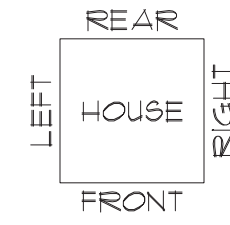

DELUXE SUNROOM W/
COVERED PORCH
SEE PG. S7.4

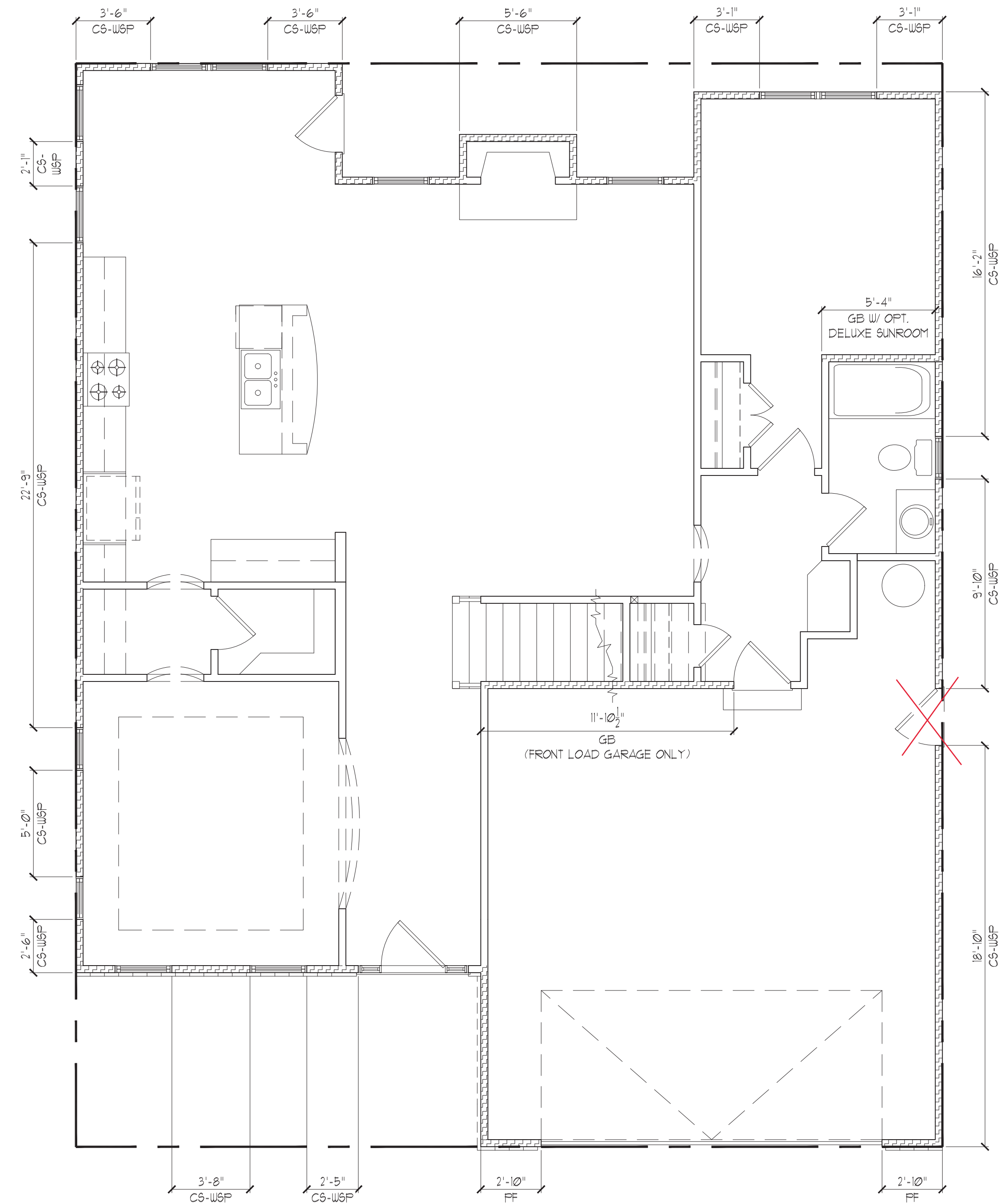

EURO

FIRST FLOOR BRACING (FT)		
	EURO	
	REQUIRED	PROVIDED
FRONT	16.1	20.4
LEFT	13.1	32.3
REAR	16.1	18.6
RIGHT	13.1	44.8

FIRST FLOOR BRACING (FT)		
	OPT. SIDE LOAD GARAGE	
	REQUIRED	PROVIDED
FRONT	16.1	22.4
LEFT	13.1	32.3
REAR	16.1	18.6
RIGHT	13.1	30.2

THESE PLANS ARE DESIGNED IN ACCORDANCE WITH ARCHITECTURAL PLANS PROVIDED BY MCKEE HOMES COMPLETED/REVISED ON 04/23/2019. IT IS THE RESPONSIBILITY OF THE CLIENT TO NOTIFY SUMMIT ENGINEERING, LABORATORY & TESTING, P.C. IF ANY CHANGES ARE MADE TO THE ARCHITECTURAL PLANS PRIOR TO CONSTRUCTION. SUMMIT ENGINEERING, LABORATORY & TESTING, P.C. CANNOT GUARANTEE THE ADEQUACY OF THESE STRUCTURAL PLANS WHEN USED WITH ARCHITECTURAL PLANS DATED DIFFERENTLY THAN THE DATE LISTED ABOVE.

STRUCTURAL MEMBERS ONLY
 ENGINEERING SEAL APPLIES ONLY TO STRUCTURAL COMPONENTS ON THIS DOCUMENT. SEAL DOES NOT INCLUDE CONSTRUCTION MEANS, METHODS, TECHNIQUES, SEQUENCES, PROCEDURES OR SAFETY PRECAUTIONS. ANY DEVIATIONS OR DISCREPANCIES ON PLANS ARE TO BE BROUGHT TO THE IMMEDIATE ATTENTION OF SUMMIT ENGINEERING, LABORATORY & TESTING, P.C. FAILURE TO DO SO WILL VOID SUMMIT ELT LIABILITY.

STRUCTURAL ANALYSIS BASED ON 2018 NCR.

FIRST FLOOR BRACING PLAN

SCALE: 1/4"=1'-0" ON 22'x34" OR 1/8"=1'-0" ON 11'x17"

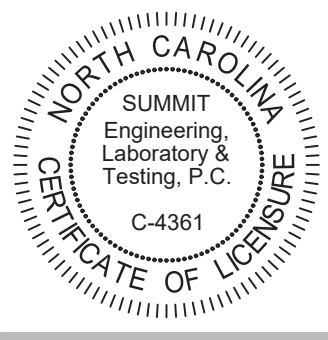

CLIENT:
 McKee Homes
 109 Hwy 61, Suite 301
 Fayetteville, NC 28301

PROJECT:
 Brooks II RH
 First Floor Bracing Plan

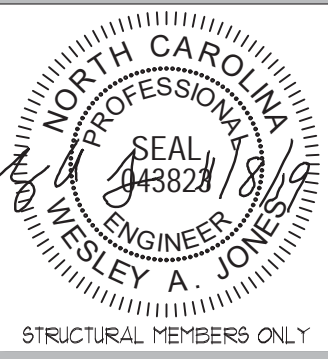

DRIVING
 DATE: 11/08/2019
 SCALE: 22x34 1/4"=1'-0"
 11x17 1/8"=1'-0"
 PROJECT # 22336R4
 DRAWN BY: EPB
 CHECKED BY: UAJ

ORIGINAL INFORMATION
 PROJECT # 22336
 DATE 09/03/2019
 REFER TO COVER SHEET FOR A COMPLETE LIST OF REVISIONS

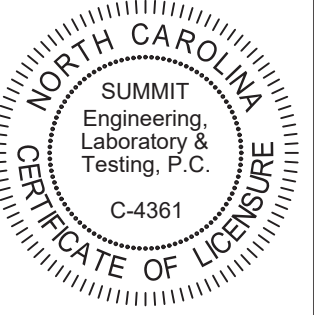

CLIENT:
 McKee Homes
 109 Hwy 51, Suite 301
 Fayetteville, NC 28301

PROJECT:
 Brooks II RH
 First Floor Bracing Plan

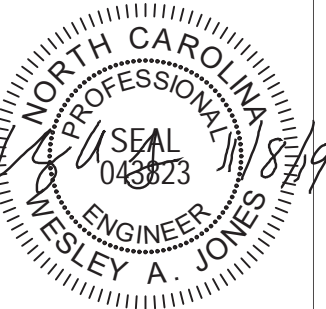

STRUCTURAL MEMBERS ONLY

DRAWING
 DATE: 11/08/09
 SCALE: 22x4 1/4"=1'-0"
 1/8"=1'-0"
 PROJECT #: 22336R4
 DRAWN BY: EPB
 CHECKED BY: UAJ

ORIGINAL INFORMATION
 PROJECT # 22336 DATE 09/03/09

REFER TO COVER SHEET FOR A COMPLETE LIST OF REVISIONS

SHEET

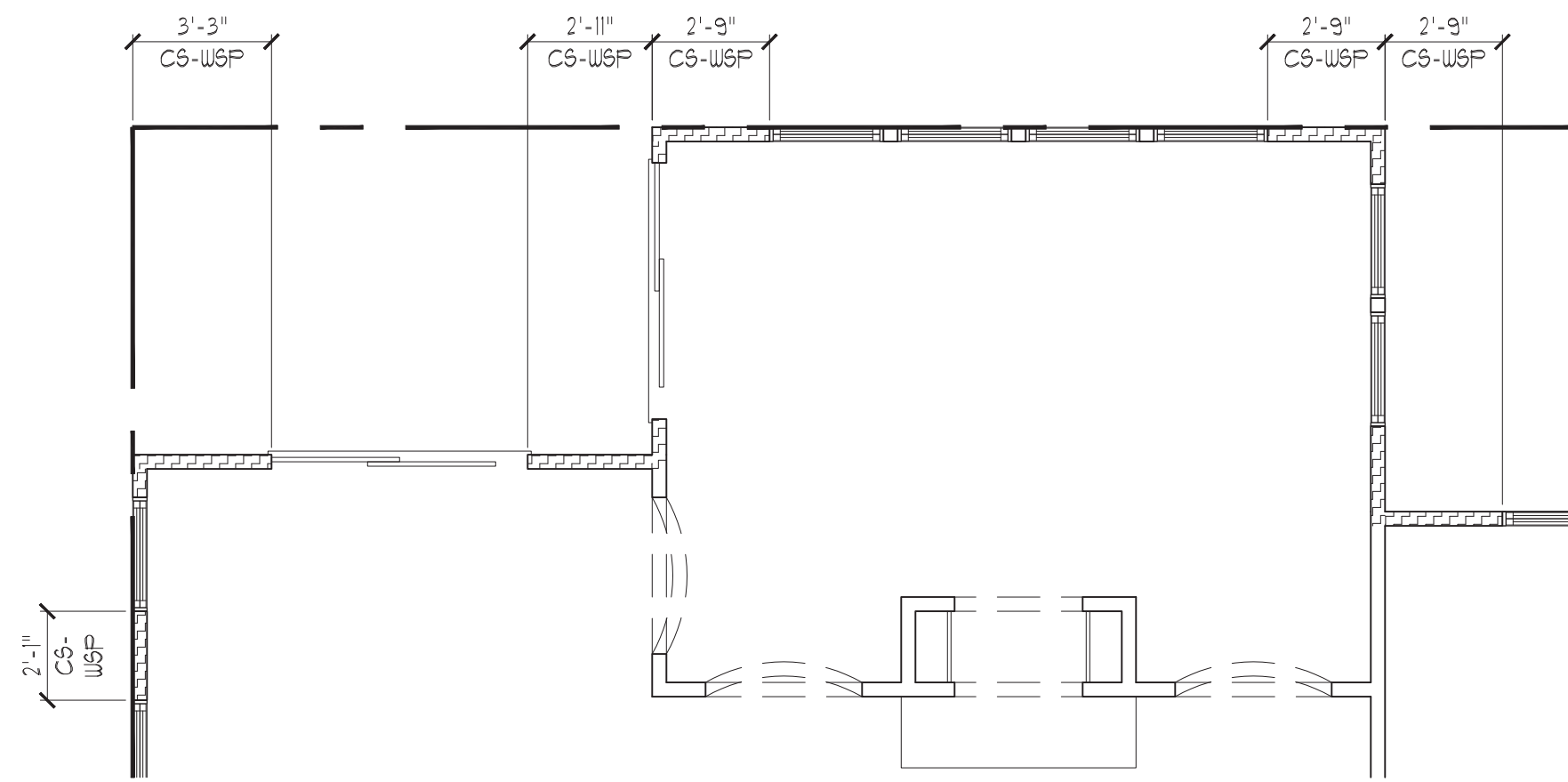

OPT. DELUXE SUNROOM
 W/ COVERED PORCH

FIRST FLOOR BRACING (FT)		
EURO		
	REQUIRED	PROVIDED
FRONT	18.4	*VARIES*
LEFT	13.1	32.3
REAR	18.4	20.1
RIGHT	13.1	44.8

STRUCTURAL MEMBERS ONLY

ENGINEERING SEAL APPLIES ONLY TO STRUCTURAL COMPONENTS ON THIS DOCUMENT. SEAL DOES NOT INCLUDE CONSTRUCTION MEANS, METHODS, TECHNIQUES, SEQUENCES, PROCEDURES OR SAFETY PRECAUTIONS. ANY DEVIATIONS OR DISCREPANCIES ON PLANS ARE TO BE BROUGHT TO THE IMMEDIATE ATTENTION OF SUMMIT ENGINEERING, LABORATORY & TESTING, P.C. FAILURE TO DO SO WILL VOID SUMMIT ELT LIABILITY.

STRUCTURAL ANALYSIS BASED ON 2018 NCR.

FIRST FLOOR BRACING PLAN

SCALE: 1/4"=1'-0" ON 22'x34" OR 1/8"=1'-0" ON 11'x11"

REQUIRED BRACED WALL PANEL CONNECTIONS				
METHOD	MATERIAL	MIN. THICKNESS	REQUIRED CONNECTION	
			@ PANEL EDGES	@ INTERMEDIATE SUPPORTS
CS-UWP	WOOD STRUCTURAL PANEL	3/8"	6d COMMON NAILS @ 6" O.C.	6d COMMON NAILS @ 12" O.C.
GB	GYPHUM BOARD	1/2"	5d COOLER NAILS" @ 1" O.C.	5d COOLER NAILS" @ 1" O.C.
UWP	WOOD STRUCTURAL PANEL	3/8"	6d COMMON NAILS @ 6" O.C.	6d COMMON NAILS @ 12" O.C.
FF	WOOD STRUCTURAL PANEL	1/16"	PER FIGURE R602.10.1	PER FIGURE R602.10.1

**OR EQUIVALENT PER TABLE R102.3.5

BRACED WALL NOTES:

- WALLS SHALL BE DESIGNED IN ACCORDANCE WITH SECTION R602.10 FROM THE 2018 INTERNATIONAL RESIDENTIAL CODE WITH ALL LOCAL AND STATE AMENDMENTS.
- WALLS ARE DESIGNED FOR SEISMIC ZONES A-C AND ULTIMATE DESIGN WIND SPEEDS UP TO 130 MPH.
- REFER TO ARCHITECTURAL PLAN FOR DOOR/WINDOW OPENING SIZES. BRACING MATERIALS, METHODS AND FASTENERS SHALL BE IN ACCORDANCE WITH TABLE R602.10.1
- ALL BRACED WALL PANELS SHALL BE FULL WALL HEIGHT AND SHALL NOT EXCEED 10 FEET FOR ISOLATED PANEL METHOD AND 12 FEET FOR CONTINUOUS SHEATHING METHOD WITHOUT ADDITIONAL ENGINEERING CALCULATIONS.
- MINIMUM PANEL LENGTH SHALL BE PER TABLE R602.10.1.
- THE INTERIOR SIDE OF EXTERIOR WALLS AND BOTH SIDES OF INTERIOR WALLS SHALL BE SHEATHED CONTINUOUSLY WITH MINIMUM 1/2" GYPSUM BOARD (UNO).
- FOR CONTINUOUS SHEATHING METHOD, EXTERIOR WALLS SHALL BE SHEATHED ON ALL SHEATHABLE SURFACES INCLUDING INFILL AREAS BETWEEN BRACED WALL PANELS, ABOVE AND BELOW WALL OPENINGS, AND ON GABLE END WALLS.
- FLOORS SHALL NOT BE CANTILEVERED MORE THAN 24" BEYOND THE FOUNDATION OR BEARING WALL BELOW WITHOUT ADDITIONAL ENGINEERING CALCULATIONS.
- A BRACED WALL PANEL SHALL BE LOCATED WITHIN 12 FEET OF EACH END OF A BRACED WALL LINE.
- THE MAXIMUM EDGE DISTANCE BETWEEN BRACED WALL PANELS SHALL NOT EXCEED 21 FEET.
- MASONRY OR CONCRETE STEM WALLS WITH A LENGTH OF 48" OR LESS SUPPORTING A BRACED WALL PANEL SHALL BE DESIGNED IN ACCORDANCE WITH FIGURE R602.10.4.3 OF THE 2018 IRC OR DETAIL 2/D21.
- BRACED WALL PANEL CONNECTIONS TO FLOOR/CEILING SHALL BE CONSTRUCTED IN ACCORDANCE WITH SECTION R602.10.4.4
- BRACED WALL PANEL CONNECTIONS TO ROOF SHALL BE CONSTRUCTED IN ACCORDANCE WITH SECTION R602.10.4.5
- CRIPPLE WALLS AND WALK OUT BASEMENT WALLS SHALL BE DESIGNED IN ACCORDANCE WITH SECTION R602.10.4.6
- PORTAL WALLS SHALL BE DESIGNED IN ACCORDANCE WITH FIGURE R602.10.1 (UNO)
- ON SCHEMATIC, SHADED WALLS INDICATE BRACED WALL PANELS. ABBREVIATIONS:

GB = GYPSUM BOARD
 CS-XXX = CONT. SHEATHED
 FF = PORTAL FRAME
 UWP = WOOD STRUCTURAL PANEL
 ENG = ENGINEERED SOLUTION
 FF-ENG = ENG. PORTAL FRAME

INSTALL HOLD-DOWNS FOR BRACED WALL END CONDITIONS PER SECTION R602.10.4 AND FIGURE R602.10.3(4) OF THE 2018 NCR.

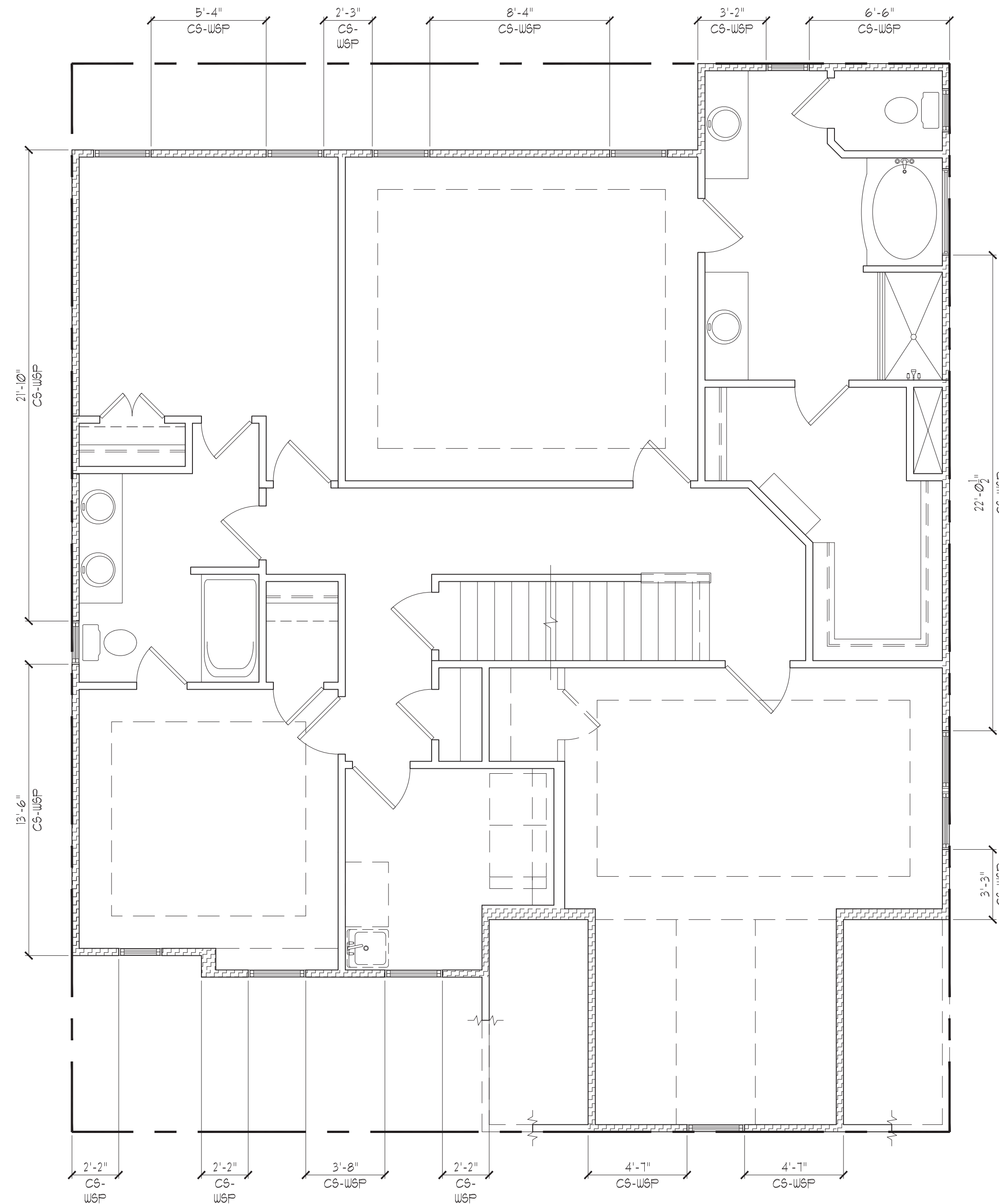
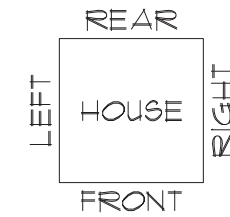

EURO

SECOND FLOOR BRACING (FT)		
CONTINUOUS SHEATHING METHOD		
	REQUIRED	PROVIDED
FRONT	7.1	16.5
LEFT	5.9	35.3
REAR	7.1	25.5
RIGHT	5.9	25.2

THESE PLANS ARE DESIGNED IN ACCORDANCE WITH ARCHITECTURAL PLANS PROVIDED BY MCKEE HOMES COMPLETED/REVISED ON 04/23/2019. IT IS THE RESPONSIBILITY OF THE CLIENT TO NOTIFY SUMMIT ENGINEERING LABORATORY & TESTING, P.C. IF ANY CHANGES ARE MADE TO THE ARCHITECTURAL PLANS PRIOR TO CONSTRUCTION. SUMMIT ENGINEERING LABORATORY & TESTING, P.C. CANNOT GUARANTEE THE ADEQUACY OF THESE STRUCTURAL PLANS WHEN USED WITH ARCHITECTURAL PLANS DATED DIFFERENTLY THAN THE DATE LISTED ABOVE.

STRUCTURAL MEMBERS ONLY

ENGINEERING SEAL APPLIES ONLY TO STRUCTURAL COMPONENTS ON THIS DOCUMENT. SEAL DOES NOT INCLUDE CONSTRUCTION MEANS, METHODS, TECHNIQUES, SEQUENCES, PROCEDURES OR SAFETY PRECAUTIONS. ANY DEVIATIONS OR DISCREPANCIES ON PLANS ARE TO BE BROUGHT TO THE IMMEDIATE ATTENTION OF SUMMIT ENGINEERING, LABORATORY & TESTING, P.C. FAILURE TO DO SO WILL VOID SUMMIT ELT LIABILITY.

STRUCTURAL ANALYSIS BASED ON 2018 NCR.

SECOND FLOOR BRACING PLAN

SCALE: 1/4"=1'-0" ON 22'x34" OR 1/8"=1'-0" ON 11'x11"

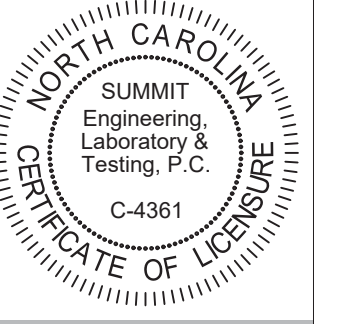

CLIENT:
 McKee Homes
 1029 Hwy 61, Suite 301
 Fayetteville, NC 28301

PROJECT:
 Brooks II RH
 Second Floor Bracing Plan

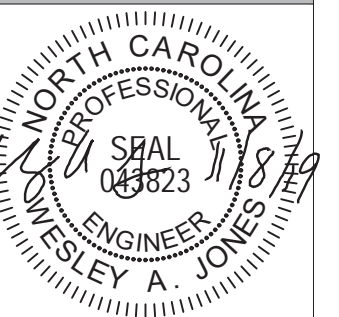

STRUCTURAL MEMBERS ONLY

DRAWING
 DATE: 11/08/2019
 SCALE: 22x34 1/4"=1'-0"
 11x11 1/8"=1'-0"
 PROJECT # 22336R4
 DRAWN BY: EPB
 CHECKED BY: WAJ

ORIGINAL INFORMATION
 PROJECT # 22336
 DATE 09/03/2019

REFER TO COVER SHEET FOR A COMPLETE LIST OF REVISIONS

SHEET

58.3

DESIGN SPECIFICATIONS:

Construction Type: Commercial Residential

Applicable Building Codes:

- 2018 North Carolina Residential Building Code with All Local Amendments
ASCE 7-10: Minimum Design Loads for Buildings and Other Structures

Design Loads:

- 1. Roof Live Loads
11. Conventional 2x 20 PSF
12. Truss 20 PSF
12.1. Attic Truss 60 PSF
2. Roof Dead Loads
21. Conventional 2x 10 PSF
22. Truss 20 PSF
3. Snow
31. Importance Factor 1.0
4. Floor Live Loads
41. Typ. Dwelling 40 PSF
42. Sleeping Areas 30 PSF
43. Decks 40 PSF
44. Passenger Garage 50 PSF
5. Floor Dead Loads
51. Conventional 2x 10 PSF
52. I-Joist 15 PSF
53. Floor Truss 15 PSF
6. Ultimate Design Wind Speed (3 sec. gust) 130 MPH
6.1. Exposure B
6.2. Importance Factor 1.0
6.3. Wind Base Shear
6.3.1. Vx =
6.3.2. Vy =

7. Component and Cladding (In PSF)

Table with 5 columns: MEAN ROOF HT., ZONE 1, ZONE 2, ZONE 3, ZONE 4, ZONE 5. Rows show wind speed ranges for different zones.

8. Seismic

- 8.1. Site Class D
8.2. Design Category C
8.3. Importance Factor 1.0
8.4. Seismic Use Group I
8.5. Spectral Response Acceleration
8.5.1. Sms = %g
8.5.2. Smi = %g
8.6. Seismic Base Shear
8.6.1. Vx =
8.6.2. Vy =
8.7. Basic Structural System (check one)
[] Bearing Wall
[] Building Frame
[] Moment Frame
[] Dual w/ Special Moment Frame
[] Dual w/ Intermediate R/C or Special Steel
[] Inverted Pendulum
8.8. Arch/Mech Components Anchored No
8.9. Lateral Design Control: Seismic [] Wind [x]
9. Assumed Soil Bearing Capacity 2000psf



STRUCTURAL PLANS PREPARED FOR:

Standard Details

PROJECT ADDRESS: TBD
OWNER: McKee Homes
109 Hay St, Suite 301
Fayetteville, NC 28301

DESIGNER:

These drawings are to be coordinated with the architectural, mechanical, plumbing, electrical, and civil drawings. This coordination is not the responsibility of the structural engineering of record (SER). Should any discrepancies become apparent, the contractor shall notify SUMMIT Engineering, Laboratory & Testing, P.C. before construction begins.

PLAN ABBREVIATIONS:

Table with 2 columns: Abbreviation and Description. Includes AB ANCHOR BOLT, AFF ABOVE FINISHED FLOOR, CJ CEILING JOIST, CLR CLEAR, DJ DOUBLE JOIST, D&P DOUBLE STUD POCKET, EE EACH END, EW EACH WAY, NTS NOT TO SCALE, OC ON CENTER, PSF POUNDS PER SQUARE FOOT, PSI POUNDS PER SQUARE INCH, PT PRESSURE TREATED, RS ROOF SUPPORT, SC STUD COLUMN, SJ SINGLE JOIST, SFF SPRUCE PINE FIR, SYP SOUTHERN YELLOW PINE, TJ TRIFLE JOIST, TRF TRIPLE STUD POCKET, TYF TYPICAL, UNO UNLESS NOTED OTHERWISE, WUF WELDED WIRE FABRIC.

Roof truss and floor joist layouts, and their corresponding loading details, were not provided to SUMMIT Engineering, Laboratory & Testing, P.C. (SUMMIT) prior to the initial design. Therefore, truss and joist directions were assumed based on the information provided by HERITAGE HOMES. Subsequent plan revisions based on roof truss and floor joist layouts shall be noted in the revision list, indicating the date the layouts were provided. Should any discrepancies become apparent, the contractor shall notify SUMMIT immediately.

SHEET LIST:

Table with 2 columns: Sheet No. and Description. Includes CS1 Cover Sheet, Specifications, Revisions; D1m Monolithic Slab Foundation Details; D1s Stem Wall Foundation Details; D1c Crawl Space Foundation Details; D1b Basement Foundation Details; D1f Framing Details.

REVISION LIST:

Table with 4 columns: Revision No., Date, Project No., Description. Row 1: 1, 11/19, -, Updated to 2018 NCRC.

GENERAL STRUCTURAL NOTES:

- 1. The design professional whose seal appears on these drawings is the structural engineer of record (SER) for this project. The SER bears the responsibility of the primary structural elements and the performance of this structure. No other party may revise, alter, or delete any structural aspects of these construction documents without written permission of SUMMIT Engineering, Laboratory & Testing, P.C. (SUMMIT) or the SER. For the purposes of these construction documents the SER and SUMMIT shall be considered the same entity.
2. The structure is only stable in its completed form. The contractor shall provide all required temporary bracing during construction to stabilize the structure.
3. The SER is not responsible for construction sequences, methods, or techniques in connection with the construction of this structure. The SER will not be held responsible for the contractor's failure to conform to the contract documents, should any non-conformities occur.
4. Any structural elements or details not fully developed on the construction drawings shall be completed under the direction of a licensed professional engineer. These shop drawings shall be submitted to SUMMIT for review before any construction begins. The shop drawings will be reviewed for overall compliance as it relates to the structural design of this project. Verification of the shop drawings for dimensions, or for actual field conditions, is not the responsibility of the SER or SUMMIT.
5. Verification of assumed field conditions is not the responsibility of the SER. The contractor shall verify the field conditions for accuracy and report any discrepancies to SUMMIT before construction begins.
6. The SER is not responsible for any secondary structural elements or non-structural elements, except for the elements specifically noted on the structural drawings.
7. This structure and all construction shall conform to all applicable sections of the International Residential Code.
8. This structure and all construction shall conform to all applicable sections of local building codes.
9. All structural assemblies are to meet or exceed to requirements of the current local building code.

FOUNDATIONS:

- 1. The structural engineer has not performed a subsurface investigation. Verification of this assumed value is the responsibility of the owner or the contractor. Should any adverse soil condition be encountered the SER must be contacted before proceeding.

- 2. The bottom of all footings shall extend below the frost line for the region in which the structure is to be constructed. However, the bottom of all footings shall be a minimum of 12" below grade.
3. Any fill shall be placed under the direction or recommendation of a licensed professional engineer.
4. The resulting soil shall be compacted to a minimum of 95% maximum dry density.
5. Excavations of footings shall be lined temporarily with a 6 mil polyethylene membrane if placement of concrete does not occur within 24 hours of excavation.
6. No concrete shall be placed against any subgrade containing water, ice, frost, or loose material.

STRUCTURAL STEEL:

- 1. Structural steel shall be fabricated and erected in accordance with the American Institute of Steel Construction "Code of Standard Practice for Steel Buildings and Bridges" and the manual of Steel Construction "Load Resistance Factor Design" latest editions.
2. Structural steel shall receive one coat of shop applied rust-inhibitive paint.
3. All steel shall have a minimum yield stress (Fy) of 36 ksi unless otherwise noted.
4. Welding shall conform to the latest edition of the American Welding Society's Structural Welding Code AWS D11. Electrodes for shop and field welding shall be class E70XX. All welding shall be performed by a certified welder per the above standards.

CONCRETE:

- 1. Concrete shall have a normal weight aggregate and a minimum compressive strength (fc) at 28 days of 3000 psi, unless otherwise noted on the plan.
2. Concrete shall be proportioned, mixed, and placed in accordance with the latest editions of ACI 318: "Building Code Requirements for Reinforced Concrete" and ACI 301: "Specifications for Structural Concrete for Buildings".
3. Air entrained concrete must be used for all structural elements exposed to freeze/thaw cycles and deicing chemicals. Air entrainment amounts (in percent) shall be within -1% to +2% of target values as follows:
3.1. Footings: 5%
3.2. Exterior Slabs: 5%
4. No admixtures shall be added to any structural concrete without written permission of the SER.

- 5. Concrete slabs-on-grade shall be constructed in accordance with ACI 302.1R-96: "Guide for Concrete Slab and Slab Construction".
6. The concrete slab-on-grade has been designed using a subgrade modulus of k=250 pci and a design loading of 200 psf. The SER is not responsible for differential settlement, slab cracking or other future defects resulting from unreported conditions not in accordance with the above assumptions.
7. Control or saw cut joints shall be spaced in interior slabs-on-grade at a maximum of 15'-0" O.C. and in exterior slabs-on-grade at a maximum of 10'-0" unless otherwise noted.
8. Control or saw cut joints shall be produced using conventional process within 4 to 12 hours after the slab has been finished.
9. Reinforcing steel may not extend through a control joint. Reinforcing steel may extend through a saw cut joint.
10. All welded wire fabric (WWF) for concrete slabs-on-grade shall be placed at mid-depth of slab. The WWF shall be securely supported during the concrete pour.

CONCRETE REINFORCEMENT:

- 1. Fibrous concrete reinforcement, or fibermesh, specified in concrete slabs-on-grade may be used for control of cracking due to shrinkage and thermal expansion/contraction, lowered water migration, an increase in impact capacity, increased abrasion resistance, and residual strength.
2. Fibermesh reinforcing to be 100% virgin polypropylene fibers containing no reprocessed olefin materials and specifically manufactured for use as concrete secondary reinforcement.
3. Application of fibermesh per cubic yard of concrete shall equal a minimum of 0.1% by volume (15 pounds per cubic yard).
4. Fibermesh shall comply with ASTM C116, any local building code requirements, and shall meet or exceed the current industry standard.
5. Steel reinforcing bars shall be new billet steel conforming to ASTM A615, grade 60.
6. Detailing, fabrication, and placement of reinforcing steel shall be in accordance with the latest edition of ACI 318: "Manual of Standard Practice for Detailing Concrete Structures"
7. Horizontal footing and wall reinforcement shall be continuous and shall have 90 degree bends, or corner bars with the same size/spacing as the horizontal reinforcement with a class B tension splice.
8. Lap reinforcement as required, a minimum of 40 bar diameters for tension or compression unless otherwise noted. Splices in masonry shall be a minimum of 48 bar diameters.

- 9. Where reinforcing dowels are required, they shall be equivalent in size and spacing to the vertical reinforcement. The dowel shall extend 48 bar diameters vertically and 20 bar diameters into the footing.
10. Where reinforcing steel is required vertically, dowels shall be provided unless otherwise noted.

WOOD FRAMING:

- 1. Solid sawn wood framing members shall conform to the specifications listed in the latest edition of the "National Design Specification for Wood Construction" (NDS). Unless otherwise noted, all wood framing members are designed to be Southern-Yellow-Pine (SYP) #2.
2. LVL or PSL engineered wood shall have the following minimum design values:
2.1. E = 1,900,000 psi
2.2. Fv = 2600 psi
2.3. Fv = 285 psi
2.4. Fc = 180 psi
3. Wood in contact with concrete, masonry, or earth shall be pressure treated in accordance with AWPA standard C-15. All other moisture exposed wood shall be treated in accordance with AWPA standard C-2
4. Nails shall be common wire nails unless otherwise noted.
5. Lag screws shall conform to ANSI/ASME standard B18.2.1-1981. Lead holes for lag screws shall be in accordance with NDS specifications.
6. All beams shall have full bearing on supporting framing members unless otherwise noted.
7. Exterior and load bearing stud walls are to be 2x4 SYP #2 @ 16" O.C. unless otherwise noted. Studs shall be continuous from the sole plate to the double top plate. Studs shall only be discontinuous at headers for window/door openings. A minimum of one king stud shall be placed at each end of the header. King studs shall be continuous.
8. Individual studs forming a column shall be attached with one 10d nail @ 6" O.C. staggered. The stud column shall be continuous to the foundation or beam. The column shall be properly blocked at all floor levels to ensure proper load transfer.
9. Multi-ply beams shall have each ply attached with (3) 10d nails @ 24" O.C.
10. Four and five ply beams shall be bolted together with (2) rows of 1/2" diameter through bolts staggered @ 16" O.C. unless noted otherwise.

WOOD TRUSSES:

- 1. The wood truss manufacturer/fabricator is responsible for the design of the wood trusses. Submit sealed shop drawings and supporting calculations to the SER for review prior to fabrication. The SER shall have a minimum of five (5) days for review. The review by the SER shall review for overall compliance with the design documents. The SER shall assume no responsibility for the correctness for the structural design for the wood trusses.
2. The wood trusses shall be designed for all required loadings as specified in the local building code, the ASCE Standard "Minimum Design Loads for Buildings and Other Structures," (ASCE 7-10), and the loading requirements shown on these specifications. The truss drawings shall be coordinated with all other construction documents and provisions provided for loads shown on these drawings including but not limited to HVAC equipment, piping, and architectural fixtures attached to the trusses.
3. The trusses shall be designed, fabricated, and erected in accordance with the latest edition of the "National Design Specification for Wood Construction," (NDS) and "Design Specification for Metal Plate Connected Wood Trusses," (ASCE 7-10), and the loading requirements shown on these specifications. The truss drawings shall be coordinated with all other construction documents and provisions provided for loads shown on these drawings including but not limited to HVAC equipment, piping, and architectural fixtures attached to the trusses.
4. The truss manufacturer shall provide adequate bracing information in accordance with "Commentary and Recommendations for Handling, Installing, and Bracing Metal Plate Connected Wood Trusses" (HIB-91). This bracing, both temporary and permanent, shall be shown on the shop drawings. Also, the shop drawings shall show the required attachments for the trusses.
5. Any chords or truss webs shown on these drawings have been shown as a reference only. The final design of the trusses shall be per the manufacturer.

EXTERIOR WOOD FRAMED DECKS:

- 1. Decks are to be framed in accordance with local building codes and as referenced on the structural plans, either through code references or construction details.
WOOD STRUCTURAL PANELS:
1. Fabrication and placement of structural wood sheathing shall be in accordance with the APA Design/Construction Guide "Residential and Commercial," and all other applicable APA standards.
2. All structurally required wood sheathing shall bear the mark of the APA.

- 3. Wood wall sheathing shall comply with the requirements of local building codes for the appropriate state as indicated on these drawings. Refer to wall bracing notes in plan set for more information. Sheathing shall be applied with the long direction perpendicular to framing, unless noted otherwise.
4. Roof sheathing shall be APA rated sheathing exposure 1 or 2. Roof sheathing shall be continuous over two supports and attached to its supporting roof framing with (1)-8d CC nail at 6" o/c at panel edges and at 12" o/c in panel field unless otherwise noted on the plans. Sheathing shall be applied with the long direction perpendicular to framing. Sheathing shall have a span rating consistent with the framing spacing. Use suitable edge support by use of plywood clips or lumber blocking unless otherwise noted. Panel end joints shall occur over framing. Apply building paper over the sheathing as required by the state Building Code.
5. Wood floor sheathing shall be APA rated sheathing exposure 1 or 2. Attach sheathing to its supporting framing with (1)-8d CC ringshank nail at 6" o/c at panel edges and at 12" o/c in panel field unless otherwise noted on the plans. Sheathing shall be applied perpendicular to framing. Sheathing shall have a span rating consistent with the framing spacing. Use suitable edge support by use of T&G plywood or lumber blocking unless otherwise noted. Panel end joints shall occur over framing. Apply building paper over the sheathing as required by the state Building Code.
6. Sheathing shall have a 1/8" gap at panel ends and edges as recommended in accordance with the APA.

STRUCTURAL FIBERBOARD PANELS:

- 1. Fabrication and placement of structural fiberboard sheathing shall be in accordance with the applicable AFA standards.
2. All structurally required fiberboard sheathing shall bear the mark of the AFA.
3. Fiberboard wall sheathing shall comply with the requirements of local building codes for the appropriate state as indicated on these drawings. Refer to wall bracing notes in plan set for more information.
4. Sheathing shall have a 1/8" gap at panel ends and edges as recommended in accordance with the AFA.

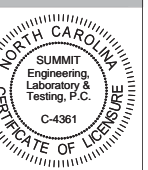

CLIENT: McKee Homes, LLC
109 Hay Street, Suite 301
Fayetteville, NC 28301

PROJECT: Standard Details
COVER SHEET

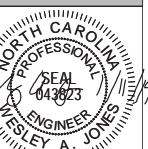

STRUCTURAL MEMBERS ONLY
DRAWING DATE: 09/26/19
SCALE: 2024 1/4" = 1'-0"
PROJECT: 4-4249000
DRAWN BY: EPB
CHECKED BY: JAU

REFER TO COVER SHEET FOR A COMPLETE LIST OF REVISIONS

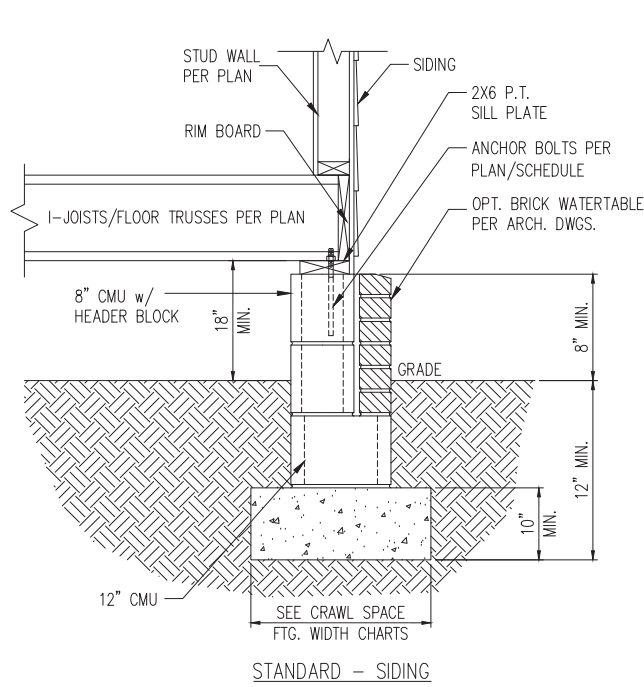

STANDARD - SIDING

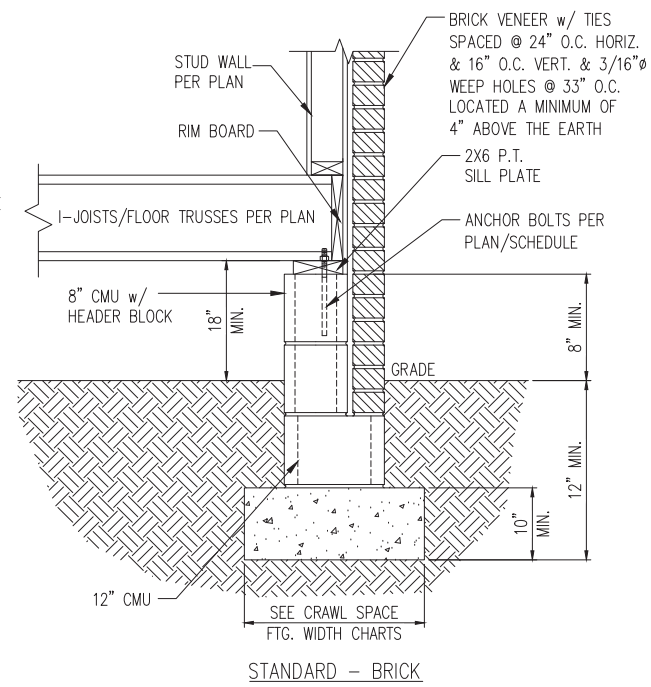

STANDARD - BRICK

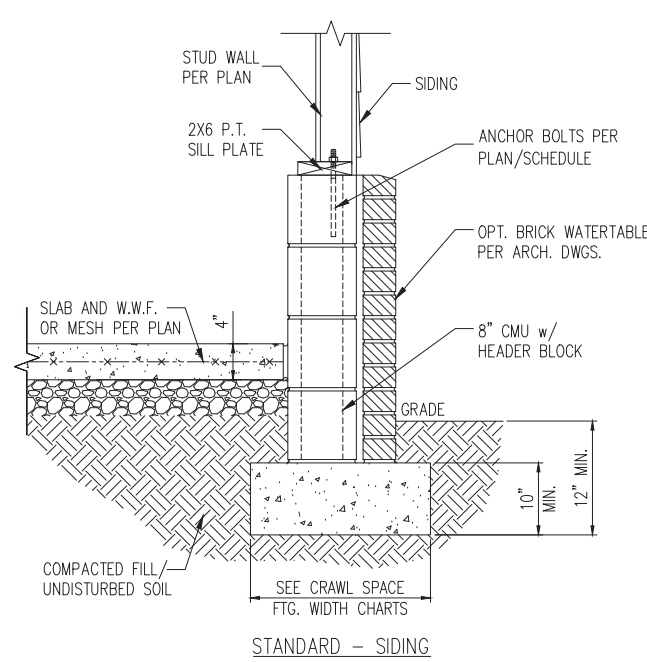

STANDARD - SIDING

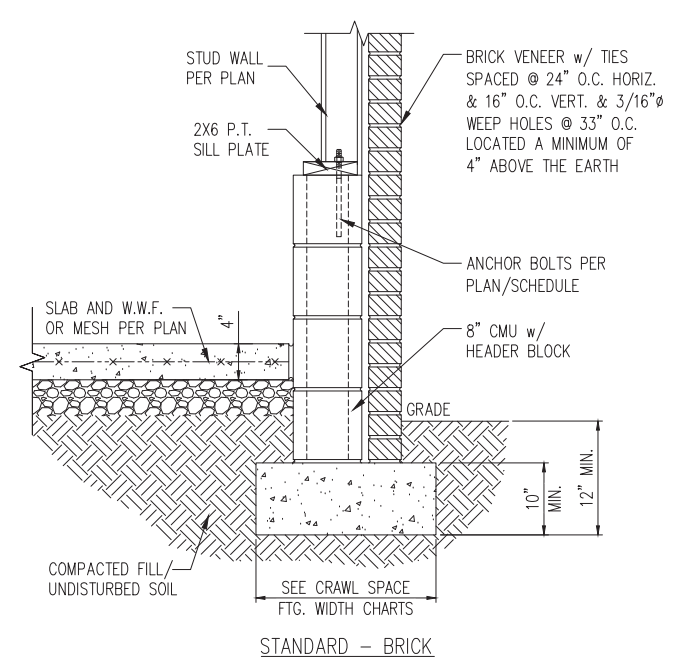

STANDARD - BRICK

1 TYP. FOUNDATION WALL DETAIL
D1c N.T.S.

2 TYP. GARAGE CURB DETAIL
D1c N.T.S.

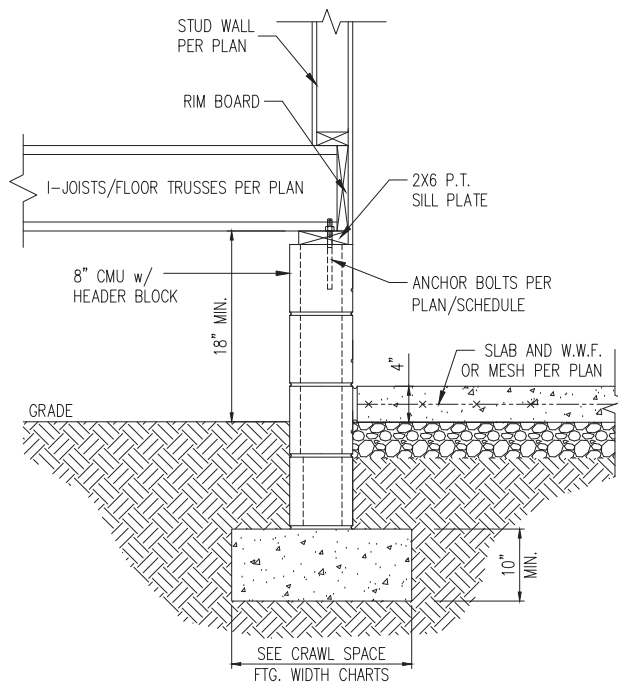

3 HOUSE/GARAGE WALL DETAIL
D1c N.T.S.

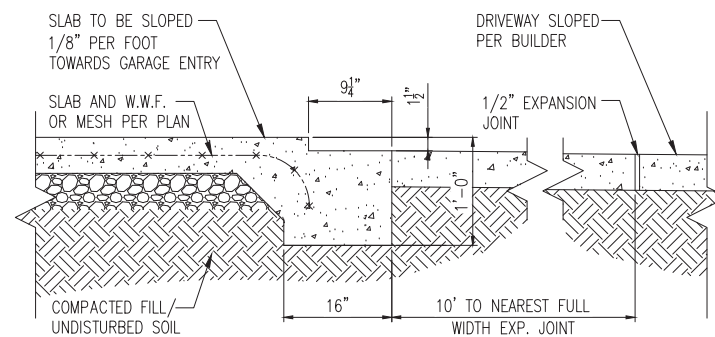

4 SLAB AT GARAGE DOOR
D1c N.T.S.

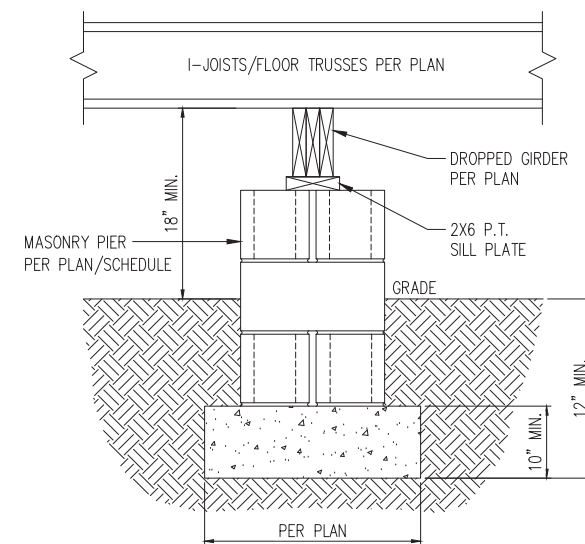

5 TYP. PIER & GIRDER DETAIL
D1c N.T.S.

PIER SIZE AND HEIGHT SCHEDULE

SIZE	HOLLOW	SOLID
8"x16"	UP TO 32" HEIGHT	UP TO 5'-0" HEIGHT
12"x16"	UP TO 48" HEIGHT	UP TO 9'-0" HEIGHT
16"x16"	UP TO 64" HEIGHT	UP TO 12'-0" HEIGHT*
24"x24"	UP TO 96" HEIGHT	UP TO 12'-0" HEIGHT*

* (4) #4 CONT. REBAR w/ #3 STIRRUPS @ 16" O.C. AND 24" MIN. LAP JOINTS

CRAWL SPACE FOOTING WIDTH

# OF STORIES	WIDTH BASED ON SOIL BEARING CAPACITY		
	1500 PSF	2000 PSF	2500 PSF
1 STORY - STD.	16"	16"	16"
1 STORY - BRICK VENEER	21"*	21"*	21"*
2 STORY - STD.	16"	16"	16"
2 STORY - BRICK VENEER	21"*	21"*	21"*
3 STORY - STD.	23"	18"	18"
3 STORY - BRICK VENEER	32"*	24"*	24"*

*5" BRICK LEDGE HAS BEEN ADDED TO THE CRAWL SPACE FOOTING WIDTH FOR BRICK SUPPORT

WALL ANCHOR SCHEDULE

TYPE OF ANCHOR	MIN. CONC. EMBEDMENT	SPACING EMBEDMENT	INTERIOR WALL	EXTERIOR WALL
1/2" dia A307 BOLTS w/ STD. 90° BEND	7"	6'-0"	YES	YES
SST - MAS	4"	5'-0"	NO	YES
HILTI KWIK BOLT KBI 1/2-2-3/4	2-1/4"	6'-0"	YES	NO
1/2" dia HILTI THREADED ROD w/ HIT HY150 ADHESIVE	7"	6'-0"	YES	YES

NOTE: INSTALL ALL ANCHORS 12" MAX. FROM ALL BOTTOM PLATE ENDS AND JOINTS.

NOTES:

- REFER TO GENERAL NOTES & SPECIFICATIONS ON COVERSHEET FOR ADDITIONAL INFORMATION.
- PROVIDE 6 MIL VAPOR BARRIER UNDER ALL SLABS-ON-GRADE.
- SEE ARCH. DWGS. FOR ALL TOP OF THE SLAB ELEVATIONS, SLOPES AND DEPRESSIONS.
- REFER TO STRUCTURAL PLANS AND FRAMING DETAILS FOR BRACED WALL PANEL LAYOUT, DIMENSIONS, ATTACHMENT AND CONNECTIONS
- REFER TO LOCAL AND STATEWIDE CODES FOR ADDITIONAL AMENDMENTS AND REQUIREMENTS NOT SHOWN
- PERIMETER INSULATION SHOWN AS REQUIRED BY LOCAL CLIMATE ZONE. INSTALL PER TABLE N1102.2.10 OF THE 2018 NCRS

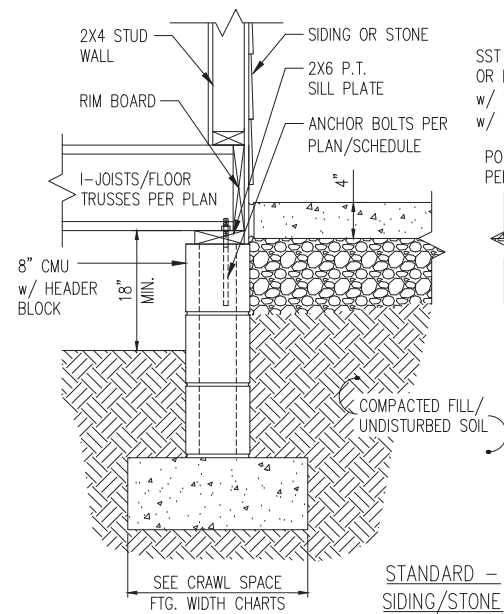

STANDARD - SIDING/STONE

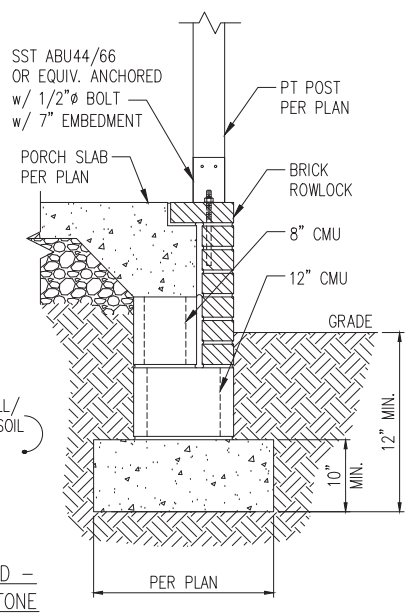

STANDARD - BRICK

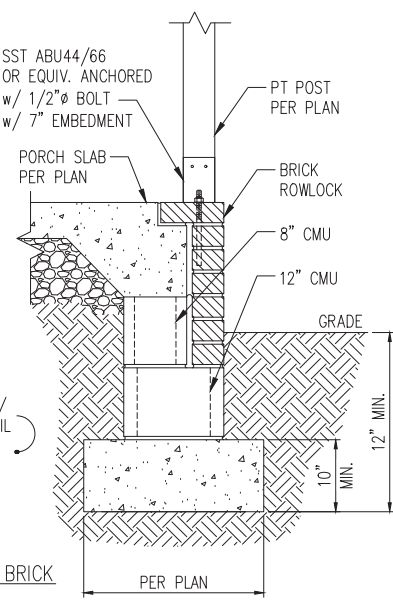

STANDARD - SIDING/STONE

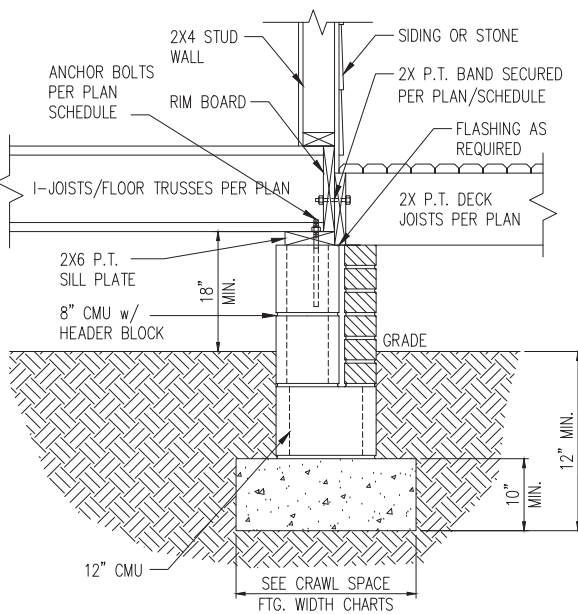

STANDARD - BRICK

1 TYP. FRONT PORCH DETAIL
D2c N.T.S.

2 DECK ATTACHMENT DETAIL
D2c N.T.S.

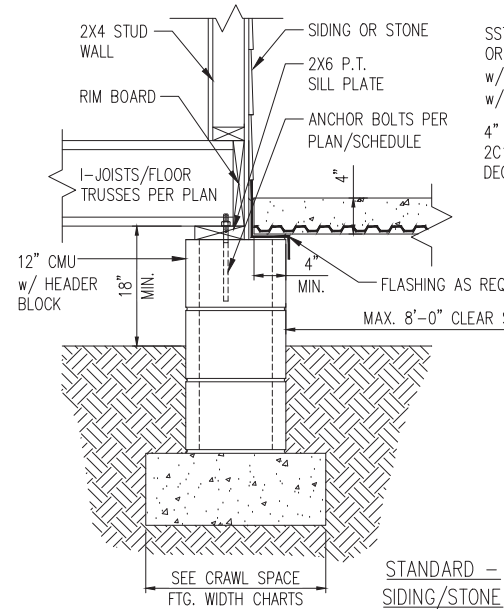

STANDARD - SIDING/STONE

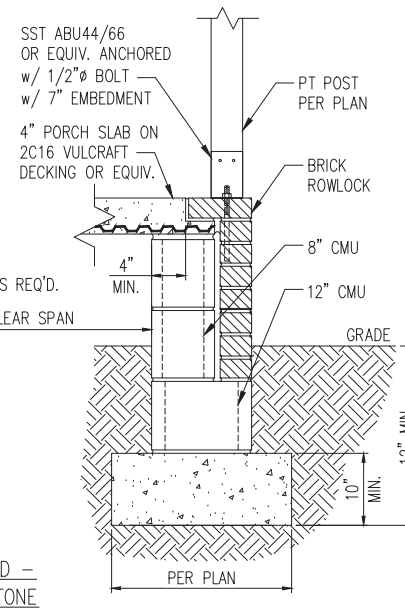

STANDARD - BRICK

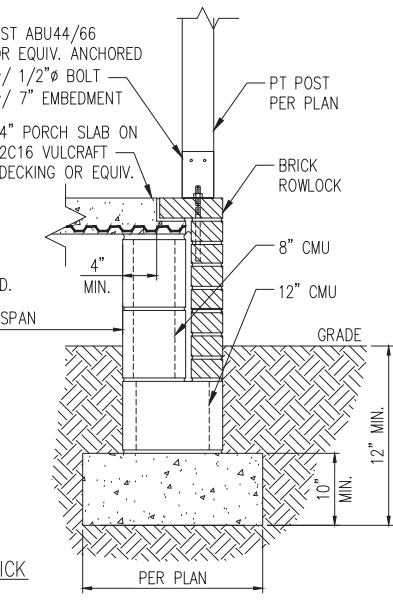

STANDARD - BRICK

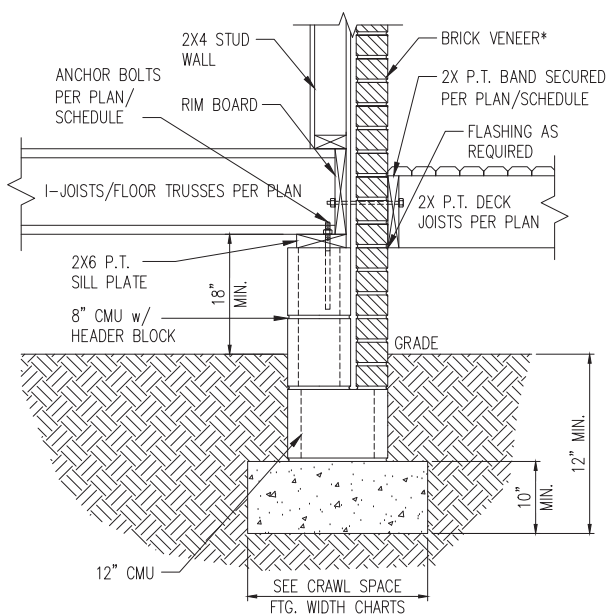

1a FRONT PORCH DETAIL w/ SUSPENDED SLAB
D2c N.T.S.

3 DECK ATTACHMENT DETAIL W/ BRICK
D2c N.T.S.

DECK ATTACHMENT SCHEDULE (ALL STRUCTURES EXCEPT BRICK)

FASTENERS	MAX. 8'-0" JOIST SPAN	MAX. 16'-0" JOIST SPAN
5/8" GALV. BOLTS w/ NUT & WASHER ^b	(1) @ 3'-6" O.C.	(1) @ 1'-8" O.C.
AND	AND	AND
12d COMMON GALV. NAILS ^c	(2) @ 8" O.C.	(3) @ 6" O.C.

- a. ATTACHMENT INTERPOLATION BETWEEN 8' AND 16' JOIST SPANS IS ALLOWED.
- b. MINIMUM EDGE DISTANCE FOR BOLTS IS 2 1/2".
- c. NAILS MUST PENETRATE THE SUPPORTING STRUCTURE BAND A MINIMUM OF 1 1/2"

DECK ATTACHMENT SCHEDULE (BRICK STRUCTURES)

FASTENERS	MAX. 8'-0" JOIST SPAN	MAX. 16'-0" JOIST SPAN
5/8" GALV. BOLTS w/ NUT & WASHER ^b	(1) @ 2'-4" O.C.	(1) @ 1'-4" O.C.

- a. ATTACHMENT INTERPOLATION BETWEEN 8' AND 16' JOIST SPANS IS ALLOWED.
- b. MINIMUM EDGE DISTANCE FOR BOLTS IS 2 1/2".

CRAWL SPACE FOOTING WIDTH

# OF STORIES	WIDTH BASED ON SOIL BEARING CAPACITY		
	1500 PSF	2000 PSF	2500 PSF
1 STORY - STD.	16"	16"	16"
1 STORY - BRICK VENEER	21"*	21"*	21"*
2 STORY - STD.	16"	16"	16"
2 STORY - BRICK VENEER	21"*	21"*	21"*
3 STORY - STD.	23"	18"	18"
3 STORY - BRICK VENEER	32"*	24"*	24"*

*5" BRICK LEDGE HAS BEEN ADDED TO THE CRAWL SPACE FOOTING WIDTH FOR BRICK SUPPORT

*BRICK TIES SPACED @ 24" O.C. HORIZ. & 16" O.C. VERT. AND 3/16" WEEP HOLES @ 33" O.C. LOCATED A MINIMUM OF 4" ABOVE THE EARTH

- NOTES:
1. REFER TO GENERAL NOTES & SPECIFICATIONS ON COVERSHEET FOR ADDITIONAL INFORMATION.
 2. PROVIDE 6 MIL VAPOR BARRIER UNDER ALL SLABS-ON-GRADE.
 3. SEE ARCH. DWGS. FOR ALL TOP OF THE SLAB ELEVATIONS, SLOPES AND DEPRESSIONS.
 4. REFER TO STRUCTURAL PLANS AND FRAMING DETAILS FOR BRACED WALL PANEL LAYOUT, DIMENSIONS, ATTACHMENT AND CONNECTIONS
 5. REFER TO LOCAL AND STATEWIDE CODES FOR ADDITIONAL AMENDMENTS AND REQUIREMENTS NOT SHOWN
 6. PERIMETER INSULATION SHOWN AS REQUIRED BY LOCAL CLIMATE ZONE. INSTALL PER TABLE N1102.2.10 OF THE 2018 NCRS

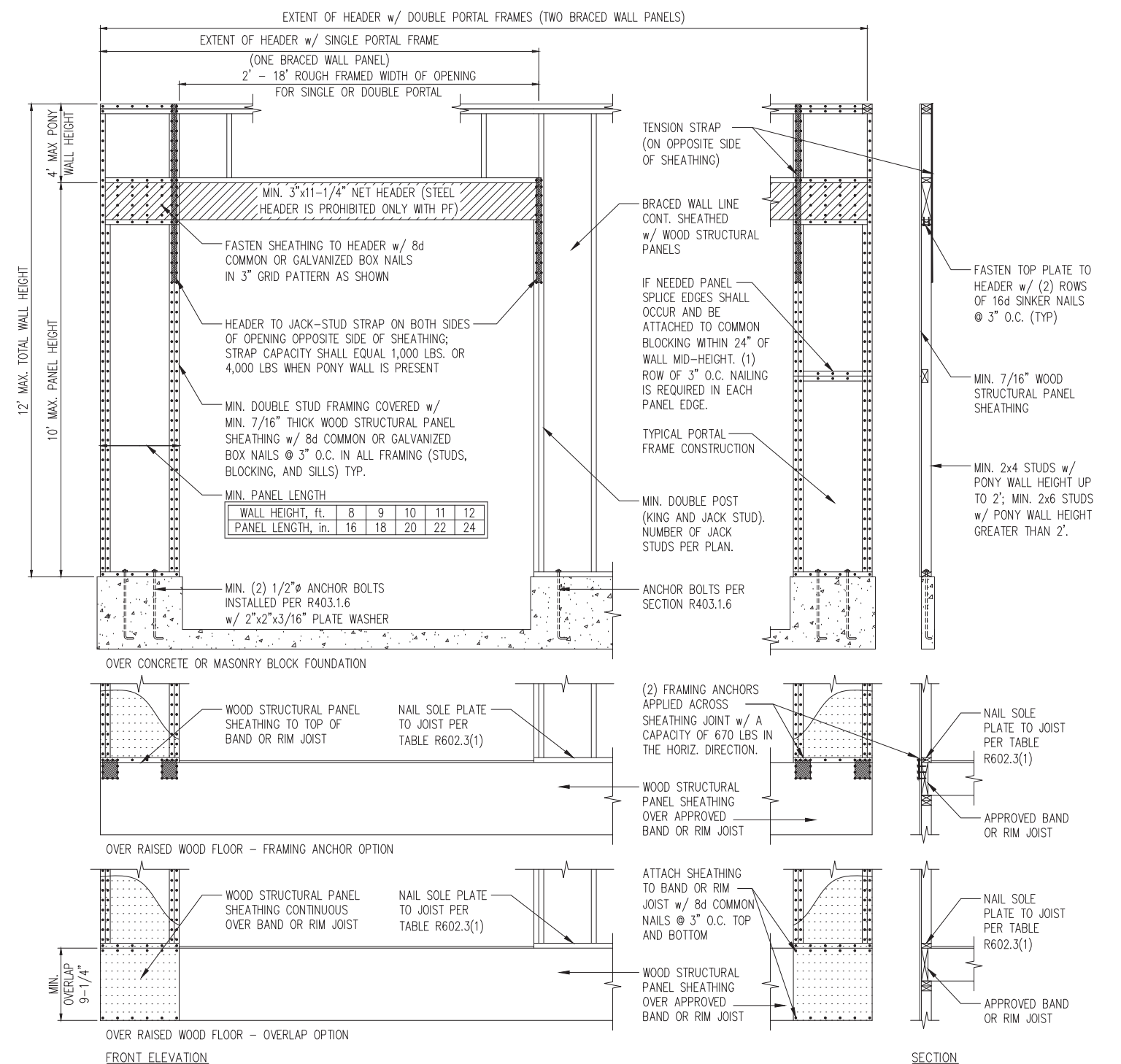

1 METHOD PF: PORTAL FRAME DETAIL
D1f 3/8" = 1'-0"