

LINE LEGEND:

- Subject Boundary Surveyed
- - - Subject Boundary Not Surveyed
- Adjacent Property Lines
- Abandoned Property Lines
- Right of Way Lines
- Center of Right-of-Way
- Easement Lines
- Survey Tie Lines
- Minimum Building Setback
- OHE Overhead Electric Lines
- Water Line
- x Wire Pasture Fence
- Woods Line (approximate)

**Town of Coats ~ RA
Minimum Building
Setback Requirements**

FRONT: 40' from R/W
REAR: 30'
SIDE: 15'
MAXIMUM HEIGHT: 35'

FEMA FLOOD HAZARD STATEMENT
The subject property shown on this plat is NOT located within the FEMA 1% Annual Chance Flood Hazard Area "Zone A" or "Zone AE" as shown on FIRM Number: 3720068000 J Effective date: 10/3/2006

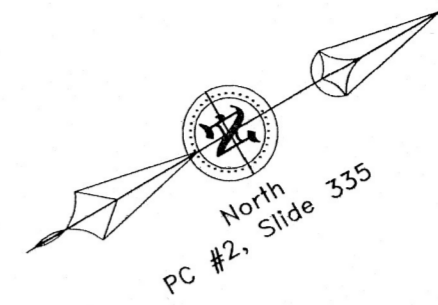

- SYMBOLS & ABBREVIATIONS:**
- EIP/EIS... Existing Iron Pipe or Stake
 - ERB..... Existing ReBar Stake
 - ERRS... Existing Rail Road Spike
 - EPK..... Existing Parker-Kaylon Nail
 - EMN..... Existing Magnetic Nail
 - ECS..... Existing Cotton Picker Spindle
 - ☒ ECM..... Existing Concrete Monument
 - AG/BG..... Above/Below Ground Surface
 - △ CP..... Calculated Point (not set)
 - ⊙ CNTRL..... Control Point - Grid Coordinates
 - ISS..... Iron Stake Set (#4 rebar)
 - MNS..... Magnetic Nail Set
 - CSS..... Cotton Spindle Set
 - FH..... Fire Hydrant
 - PP..... Power Pole
 - OHE..... Overhead Electric Lines
 - Land Hook (Property combined)
 - C/L..... Centerline of Road or Easement
 - R/W..... Right-of-Way
 - D.B..... Deed Book
 - P.B/P.C..... Plat Book / Plat Cabinet
 - M.B..... Map Book
 - NC.PIN..... Parcel Identifier Number
 - Ac..... Acres (Area of property)
 - SF..... Square Feet
 - [123]..... House Address

- SURVEY NOTES:**
- Iron Stakes (1/2" Re-bar) set at all new property corners unless labeled otherwise.
 - Magnetic Nails set at all points in paved road surfaces, unless otherwise indicated.
 - Areas determined by coordinate method.
 - All distances & dimensions are horizontal ground distances unless otherwise indicated.
 - No NC Geodetic Survey monuments or other such control monuments were found within 2,000 feet of the subject property unless otherwise shown hereon.
 - This survey is based upon the references shown as taken from County GIS records. No title search was provided for this survey. A complete title search by a licensed attorney may reveal other easements, restrictions, and title issues not made available to the surveyor.
 - No underground utilities were marked by providers prior to this survey. Call NC 811 prior to any excavation to locate any underground utilities.
 - Wetlands, soil conditions, or other environmental features were not delineated for this survey.

North Carolina
Harnett County

I, Robert Edward Godwin, Jr., certify that this plat was drawn under my supervision from an actual survey made under my supervision (deed description recorded in Book 3735, Page 597), that the boundaries not surveyed are shown as broken lines plotted from information found in references as shown hereon; that the ratio of precision as calculated is 1:10,000+; and that this plat was prepared in accordance with G. S. 47-30 as amended. Witness my original signature, registration number and seal this the 7th day of JAN., 2020.

I further certify that the survey is of an existing parcel or parcels of land and does not create a new street or change an existing street.

Robert E. Godwin, Jr., P.L.S.
License Number: L-3790

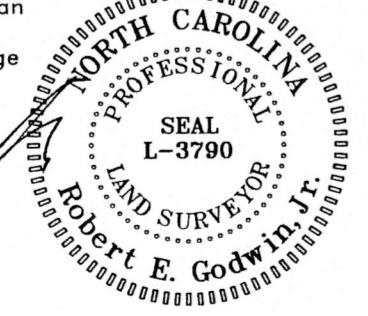

Gerald W. Hayes, Jr.
and Linda W. Hayes
DB 3354, Pg. 787 (Tract Two)
NC PIN 0691-80-5497.000

Gerald W. Hayes, Jr.
and Linda W. Hayes
DB 3354, Pg. 787 (Tract Four)
NC PIN 0691-70-3866.000

**Tract No. 4
PC #2, Slide 335
±18.10 Acres**

Rick R. & Kae A. Kamm
DB 3107, Pg. 369
NC PIN 0691-90-1679.000

Gerald W. Hayes, Jr.
and Heather Hayes Williams
DB 3354, Pg. 787 (Tract Ten)
NC PIN 0691-71-9721.000

Sammy J. Pope, et.al.
DB 1407, Pg. 299
Map #2013-157
NC PIN 0691-82-5063.000

Carol Pope McGee
DB 1108, Pg. 500
Map #2017-5-5717
NC PIN 0691-91-0945.000

Barbara P. Williams
DB 598, Pg. 223
NC PIN 0691-91-2260.000

Revisions:

January 6, 2020: Revised House Placement

"EXISTING PARCEL"
Survey For:
**Melanie J. Payne &
Richard A. Payne, Jr.**
Care of: BIM Builders

Property Address: ___ Willis Pope Rd., Angier

GROVE TOWNSHIP- HARNETT COUNTY - NORTH CAROLINA

ZONE: Town of Coats RA Parcel Number: 0691-81-5295.000

References:
-Deed Book 3735, Pg. 597
-Plat Cabinet #2, Slide 335 (Tract #4)

STREAMLINE LAND SURVEYING, Inc.
NC FIRM C-1898
870 NC 55 W, Coats, N.C. 27521
Phone: 910-897-7715

SURVEY DATE: DECEMBER 5, 2019

SCALE: 1" = 100' SURVEYED BY: REG DRAWN BY: REG

FILE: E:\0691\191205PA (ExistingParcel)

