

**Trenco**  
818 Soundside Rd  
Edenton, NC 27932

Re: 19-114808T  
KEN DAWSON PLAN 1341

The truss drawing(s) referenced below have been prepared by Truss Engineering Co. under my direct supervision based on the parameters provided by Stock Building Supply.

Pages or sheets covered by this seal: T18803234 thru T18803248

My license renewal date for the state of North Carolina is December 31, 2020.

North Carolina COA: C-0844



December 4, 2019

O'Regan, Philip

**IMPORTANT NOTE:** The seal on these truss component designs is a certification that the engineer named is licensed in the jurisdiction(s) identified and that the designs comply with ANSI/TPI 1. These designs are based upon parameters shown (e.g., loads, supports, dimensions, shapes and design codes), which were given to MiTek or TRENCO. Any project specific information included is for MiTek's or TRENCO's customers file reference purpose only, and was not taken into account in the preparation of these designs. MiTek or TRENCO has not independently verified the applicability of the design parameters or the designs for any particular building. Before use, the building designer should verify applicability of design parameters and properly incorporate these designs into the overall building design per ANSI/TPI 1, Chapter 2.

Job 19-114808T	Truss A01	Truss Type Common Supported Gable	Qty 1	Ply 1	KEN DAWSON PLAN 1341	T18803234
BMC (Middlesex, NC), Middlesex, NC - 27557,					Job Reference (optional)	

8.240 s Jul 14 2019 MiTek Industries, Inc. Tue Dec 3 17:26:38 2019 Page 1  
 ID:9ohifRTVSugSpHSw7zcUgvyCcmY-Vs6RZTntSGcodd2gl89XHX6DUCuRou3OmBQjRSyCcDF

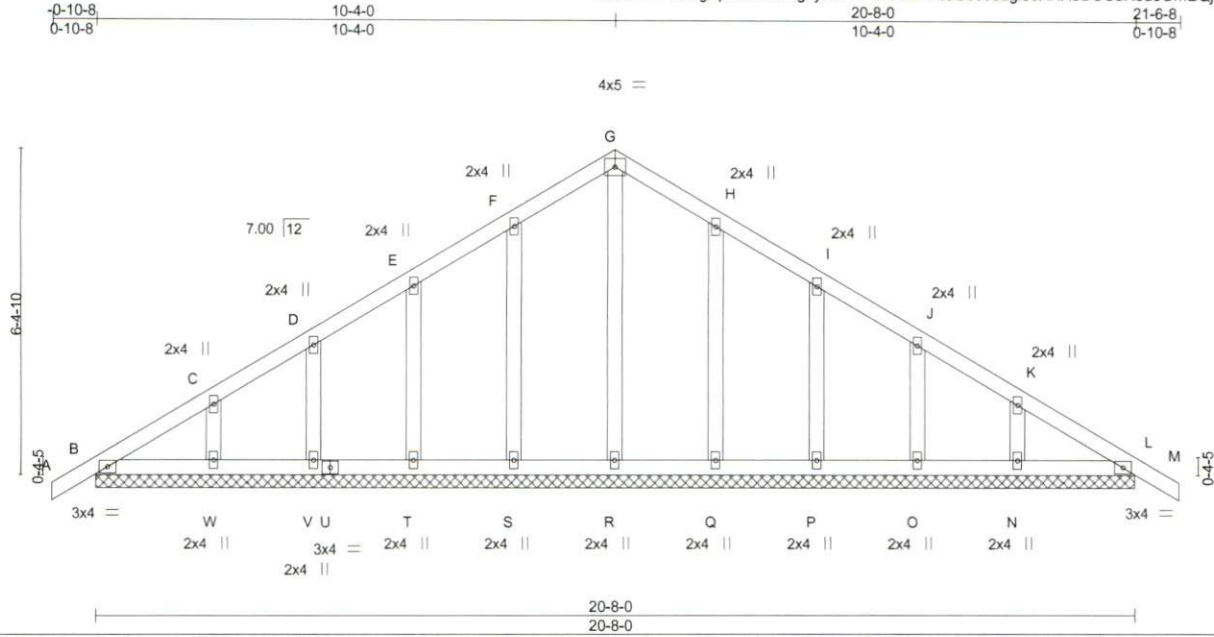

LOADING (psf)	SPACING-	CSI.	DEFL.	in (loc)	l/defl	L/d	PLATES	GRIP
TCLL (roof) 20.0	2-0-0	TC 0.05	Vert(LL) -0.00	L	n/r	120	MT20	244/190
Snow (Pf/Pg) 10.4/15.0	Plate Grip DOL 1.00	BC 0.04	Vert(CT) 0.00	L	n/r	120		
TCDL 10.0	Lumber DOL 1.15	WB 0.08	Horz(CT) 0.00	L	n/a	n/a		
BCLL 0.0 *	Rep Stress Incr YES	Matrix-S	Wind(LL) 0.00	L	n/r	90		
BCDL 10.0	Code IRC2015/TPI2014						Weight: 113 lb	FT = 20%

LUMBER-	BRACING-
TOP CHORD 2x4 SP No.2	TOP CHORD Structural wood sheathing directly applied or 6-0-0 oc purlins.
BOT CHORD 2x4 SP No.2	BOT CHORD Rigid ceiling directly applied or 10-0-0 oc bracing.
OTHERS 2x4 SP No.3	

**REACTIONS.** All bearings 20-8-0.  
 (lb) - Max Horz B=-138(LC 12)  
 Max Uplift All uplift 100 lb or less at joint(s) B, S, T, V, W, Q, P, O, N  
 Max Grav All reactions 250 lb or less at joint(s) B, R, S, T, V, W, Q, P, O, N, L

**FORCES.** (lb) - Max. Comp./Max. Ten. - All forces 250 (lb) or less except when shown.

- NOTES-**
- Unbalanced roof live loads have been considered for this design.
  - Wind: ASCE 7-10; Vult=120mph (3-second gust) Vasd=95mph; TCDL=6.0psf; BCDL=6.0psf; h=30ft; Cat. II; Exp B; Enclosed; MWFRS (envelope) gable end zone and C-C Exterior(2) zone; C-C for members and forces & MWFRS for reactions shown; Lumber DOL=1.60 plate grip DOL=1.33
  - Truss designed for wind loads in the plane of the truss only. For studs exposed to wind (normal to the face), see Standard Industry Gable End Details as applicable, or consult qualified building designer as per ANSI/TPI 1.
  - TCLL: ASCE 7-10; Pr=20.0 psf (roof live load: Lumber DOL=1.15 Plate DOL=1.00); Pg=15.0 psf (ground snow); Pf=10.4 psf (flat roof snow: Lumber DOL=1.15 Plate DOL=1.00); Category II; Exp B; Fully Exp.; Ct=1.10
  - Unbalanced snow loads have been considered for this design.
  - This truss has been designed for greater of min roof live load of 12.0 psf or 1.00 times flat roof load of 10.4 psf on overhangs non-concurrent with other live loads.
  - Gable requires continuous bottom chord bearing.
  - Gable studs spaced at 2-0-0 oc.
  - This truss has been designed for a 10.0 psf bottom chord live load nonconcurrent with any other live loads.
  - \* This truss has been designed for a live load of 20.0psf on the bottom chord in all areas where a rectangle 3-6-0 tall by 2-0-0 wide will fit between the bottom chord and any other members.
  - Provide mechanical connection (by others) of truss to bearing plate capable of withstanding 100 lb uplift at joint(s) B, S, T, V, W, Q, P, O, N.



December 4, 2019

Job 19-114808T	Truss A02	Truss Type Common	Qty 4	Ply 1	KEN DAWSON PLAN 1341	T18803235
-------------------	--------------	----------------------	----------	----------	----------------------	-----------

BMC (Middlesex, NC), Middlesex, NC - 27557, 8.240 s Jul 14 2019 MiTek Industries, Inc. Tue Dec 3 17:26:39 2019 Page 1  
 ID:9ohifRTV5ugSpHSw?zcUgvyCcmY-\_2gpnpOVDakFFndJrgmqkFK0c9oXJWY\_rAG\_uyCcDE



Scale = 1:41.5

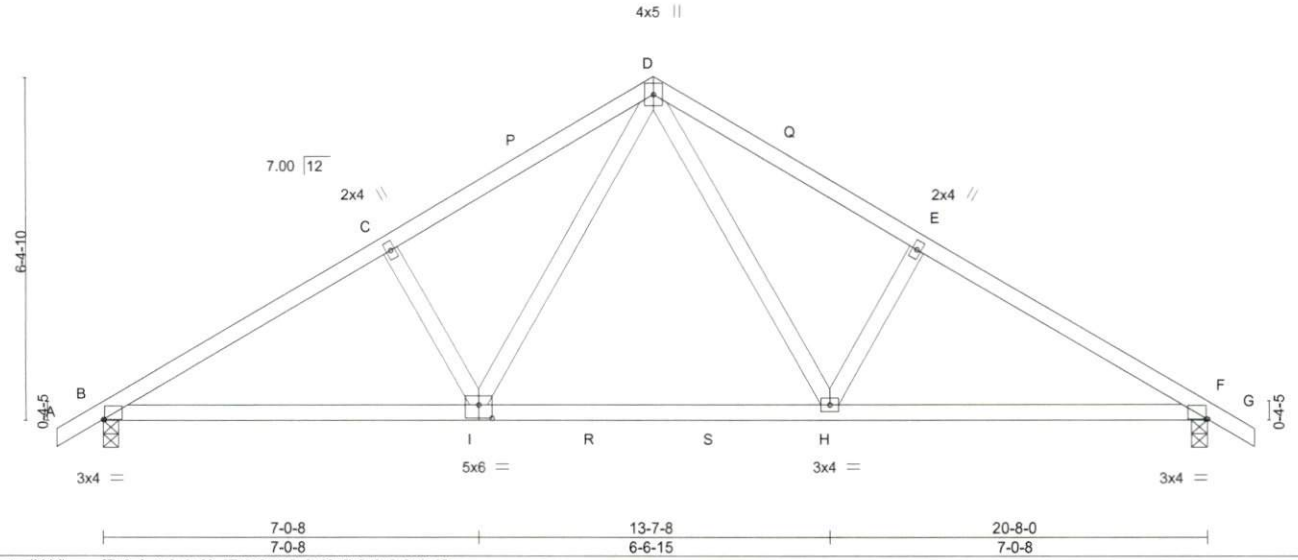

Plate Offsets (X,Y)-- [B:0-0-5,0-0-0], [F:0-0-5,0-0-0], [I:0-3-0,0-3-0]

<b>LOADING</b> (psf)	<b>SPACING-</b>	<b>CSI.</b>	<b>DEFL.</b>	<b>PLATES</b>	<b>GRIP</b>
TCLL (roof) 20.0	2-0-0	TC 0.26	in (loc) l/defl L/d	MT20	244/190
Snow (Pf/Pg) 10.4/15.0	Plate Grip DOL 1.00	BC 0.35	Vert(LL) -0.07 H-I >999 240		
TCDL 10.0	Lumber DOL 1.15	WB 0.20	Vert(CT) -0.12 H-O >999 180		
BCLL 0.0 *	Rep Stress Incr YES	Matrix-MS	Horz(CT) 0.03 F n/a n/a		
BCDL 10.0	Code IRC2015/TPI2014			Weight: 99 lb	FT = 20%

<b>LUMBER-</b>	<b>BRACING-</b>
TOP CHORD 2x4 SP 1650F 1.5E or 2x4 SP No.1 or 2x4 SP SS	TOP CHORD Structural wood sheathing directly applied or 5-3-8 oc purlins.
BOT CHORD 2x4 SP 1650F 1.5E or 2x4 SP No.1 or 2x4 SP SS	BOT CHORD Rigid ceiling directly applied or 10-0-0 oc bracing.
WEBS 2x4 SP No.3	

**REACTIONS.** (lb/size) B=664/0-3-8, F=664/0-3-8  
 Max Horz B=138(LC 13)  
 Max Uplift B=-57(LC 14), F=-57(LC 15)  
 Max Grav B=879(LC 2), F=879(LC 2)

**FORCES.** (lb) - Max. Comp./Max. Ten. - All forces 250 (lb) or less except when shown.  
 TOP CHORD B-C=-1283/145, C-D=-1160/179, D-E=-1160/179, E-F=-1283/145  
 BOT CHORD B-I=-85/1118, H-I=0/721, F-H=-38/1072  
 WEBS D-H=-65/524, E-H=-309/152, D-I=-65/523, C-I=-309/152

**NOTES-**

- Unbalanced roof live loads have been considered for this design.
- Wind: ASCE 7-10; Vult=120mph (3-second gust) Vasd=95mph; TCCL=6.0psf; BCDL=6.0psf; h=30ft; Cat. II; Exp B; Enclosed; MWFRS (envelope) gable end zone and C-C Exterior(2) zone; C-C for members and forces & MWFRS for reactions shown; Lumber DOL=1.60 plate grip DOL=1.33
- TCCL: ASCE 7-10; Pr=20.0 psf (roof live load: Lumber DOL=1.15 Plate DOL=1.00); Pg=15.0 psf (ground snow); Pf=10.4 psf (flat roof snow: Lumber DOL=1.15 Plate DOL=1.00); Category II; Exp B; Fully Exp.; Ct=1.10
- Unbalanced snow loads have been considered for this design.
- This truss has been designed for greater of min roof live load of 12.0 psf or 1.00 times flat roof load of 10.4 psf on overhangs non-concurrent with other live loads.
- This truss has been designed for a 10.0 psf bottom chord live load nonconcurrent with any other live loads.
- \* This truss has been designed for a live load of 20.0psf on the bottom chord in all areas where a rectangle 3-6-0 tall by 2-0-0 wide will fit between the bottom chord and any other members, with BCDL = 10.0psf.
- Provide mechanical connection (by others) of truss to bearing plate capable of withstanding 100 lb uplift at joint(s) B, F.



December 4, 2019

**WARNING - Verify design parameters and READ NOTES ON THIS AND INCLUDED MITEK REFERENCE PAGE MII-7473 rev. 10/03/2015 BEFORE USE.**  
 Design valid for use only with MiTek® connectors. This design is based only upon parameters shown, and is for an individual building component, not a truss system. Before use, the building designer must verify the applicability of design parameters and properly incorporate this design into the overall building design. Bracing indicated is to prevent buckling of individual truss web and/or chord members only. Additional temporary and permanent bracing is always required for stability and to prevent collapse with possible personal injury and property damage. For general guidance regarding the fabrication, storage, delivery, erection and bracing of trusses and truss systems, see **ANSI/TPI1 Quality Criteria, DSB-89 and BCSI Building Component Safety Information** available from Truss Plate Institute, 218 N. Lee Street, Suite 312, Alexandria, VA 22314.

**ENGINEERING BY**  
**TRENCO**  
 A MiTek Affiliate  
 818 Soundside Road  
 Edenton, NC 27932

Job 19-114808T	Truss A03	Truss Type Common Structural Gable	Qty 1	Ply 1	KEN DAWSON PLAN 1341	T18803236
-------------------	--------------	---------------------------------------	----------	----------	----------------------	-----------

BMC (Middlesex, NC), Middlesex, NC - 27557, 8.240 s Jul 14 2019 MiTek Industries, Inc. Tue Dec 3 17:26:41 2019 Page 1  
 ID:9ohifRTV SugSPHSw?zcUgvyCcmY-wRnaCVPmkB\_NU5nFRGIEv9kbtQjY?CvrS9fN2nyCcDC  
 -0-10-8 6-11-1 13-4-8 19-9-15 26-9-0 27-7-8  
 0-10-8 6-11-1 6-5-7 6-5-7 6-11-1 0-10-8

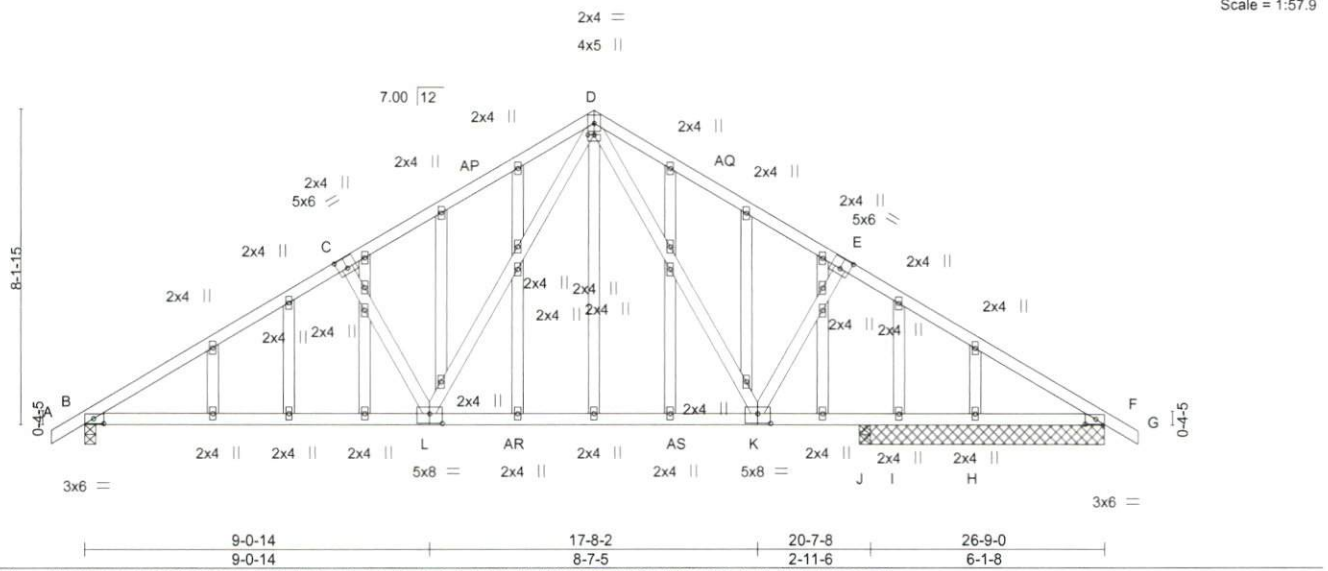

Plate Offsets (X,Y)-- [B:0-3-3,0-1-8], [C:0-3-0,0-3-4], [D:0-2-0,0-0-0], [E:0-3-0,0-3-4], [F:0-3-3,0-1-8], [K:0-4-0,0-3-0], [L:0-4-0,0-3-0]

LOADING (psf)	SPACING-	CSI.	DEFL.	PLATES	GRIP
TCLL (roof) 20.0	2-0-0	TC 0.62	in (loc) l/defl L/d	MT20	244/190
Snow (Pf/Pg) 10.4/15.0	Plate Grip DOL 1.00	BC 0.85	Vert(LL) -0.23 K-L >999 240		
TCDL 10.0	Lumber DOL 1.15	WB 0.27	Vert(CT) -0.38 K-L >647 180		
BCLL 0.0 *	Rep Stress Incr YES	Matrix-MS	Horz(CT) 0.05 AM n/a n/a		
BCDL 10.0	Code IRC2015/TPI2014			Weight: 198 lb	FT = 20%

**LUMBER-**  
 TOP CHORD 2x4 SP No.2  
 BOT CHORD 2x4 SP No.2  
 WEBS 2x4 SP No.3  
 OTHERS 2x4 SP No.3

**BRACING-**  
 TOP CHORD Structural wood sheathing directly applied or 3-10-3 oc purlins.  
 BOT CHORD Rigid ceiling directly applied or 10-0-0 oc bracing.

**REACTIONS.** All bearings 6-5-0 except (jt=length) B=0-3-8, J=0-3-8.  
 (lb) - Max Horz B=175(LC 13)  
 Max Uplift All uplift 100 lb or less at joint(s) B, H, F, J except I=251(LC 2)  
 Max Grav All reactions 250 lb or less at joint(s) I, H except B=1078(LC 2), F=940(LC 29), J=303(LC 2), F=686(LC 1)

**FORCES.** (lb) - Max. Comp./Max. Ten. - All forces 250 (lb) or less except when shown.  
 TOP CHORD B-C=-1604/191, C-D=-1469/235, D-E=-1376/237, E-F=-1528/193  
 BOT CHORD B-L=-120/1456, K-L=0/911, J-K=-63/1234, I-J=-63/1234, H-I=-63/1234, F-H=-63/1234  
 WEBS D-K=-92/576, E-K=-376/201, D-L=-82/730, C-L=-403/200

- NOTES-**
- Unbalanced roof live loads have been considered for this design.
  - Wind: ASCE 7-10; Vult=120mph (3-second gust) Vasd=95mph; TCCL=6.0psf; BCDL=6.0psf; h=30ft; Cat. II; Exp B; Enclosed; MWFRS (envelope) gable end zone and C-C Exterior(2) zone; C-C for members and forces & MWFRS for reactions shown; Lumber DOL=1.60 plate grip DOL=1.33
  - Truss designed for wind loads in the plane of the truss only. For studs exposed to wind (normal to the face), see Standard Industry Gable End Details as applicable, or consult qualified building designer as per ANSI/TPI 1.
  - TCLL: ASCE 7-10; Pr=20.0 psf (roof live load: Lumber DOL=1.15 Plate DOL=1.00); Pg=15.0 psf (ground snow); Pf=10.4 psf (flat roof snow: Lumber DOL=1.15 Plate DOL=1.00); Category II; Exp B; Fully Exp.; Ct=1.10
  - Unbalanced snow loads have been considered for this design.
  - This truss has been designed for greater of min roof live load of 12.0 psf or 1.00 times flat roof load of 10.4 psf on overhangs non-concurrent with other live loads.
  - Gable studs spaced at 2-0-0 oc.
  - This truss has been designed for a 10.0 psf bottom chord live load nonconcurrent with any other live loads.
  - \* This truss has been designed for a live load of 20.0psf on the bottom chord in all areas where a rectangle 3-6-0 tall by 2-0-0 wide will fit between the bottom chord and any other members, with BCDL = 10.0psf.
  - Provide mechanical connection (by others) of truss to bearing plate capable of withstanding 100 lb uplift at joint(s) B, H, F, J, F except (jt=lb) I=251.



December 4, 2019

Job 19-114808T	Truss A04	Truss Type Common	Qty 7	Ply 1	KEN DAWSON PLAN 1341	T18803237
					Job Reference (optional)	

BMC (Middlesex, NC), Middlesex, NC - 27557,

8.240 s Jul 14 2019 MiTek Industries, Inc. Tue Dec 3 17:26:42 2019 Page 1

ID:9ohifRTV SugSpHSW?zcuGvyCcmY-OdLyPrQOVV6E6ELS\_zDTSNHmUqAgkXy\_hpOwaDyCcDB

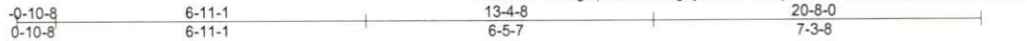

4x5 =

Scale = 1:49.5

Plate Offsets (X,Y)-- [B:0-2-0,0-1-10], [C:0-3-0,0-3-4], [E:Edge,0-1-12], [H:0-3-0,0-3-0]

LOADING (psf)	SPACING-	CSI.	DEFL.	in (loc)	l/defl	L/d	PLATES	GRIP
TCLL (roof) 20.0	2-0-0	TC 0.63	Vert(LL) -0.06	H-K	>999	240	MT20	244/190
Snow (Pf/Pg) 10.4/15.0	Plate Grip DOL 1.00	BC 0.41	Vert(CT) -0.14	H-K	>999	180		
TCDL 10.0	Lumber DOL 1.15	WB 0.73	Horz(CT) 0.02	F	n/a	n/a		
BCLL 0.0 *	Rep Stress Incr YES	Matrix-MS						
BCDL 10.0	Code IRC2015/TPI2014						Weight: 113 lb	FT = 20%

**LUMBER-**  
 TOP CHORD 2x4 SP 1650F 1.5E or 2x4 SP No.1 or 2x4 SP SS  
 BOT CHORD 2x4 SP 1650F 1.5E or 2x4 SP No.1 or 2x4 SP SS  
 WEBS 2x4 SP No.3

**BRACING-**  
 TOP CHORD Structural wood sheathing directly applied or 5-0-15 oc purlins, except end verticals.  
 BOT CHORD Rigid ceiling directly applied or 10-0-0 oc bracing.

**REACTIONS.** (lb/size) B=660/0-3-8, F=623/0-4-0  
 Max Horz B=134(LC 11)  
 Max Grav B=874(LC 2), F=820(LC 2)

**FORCES.** (lb) - Max. Comp./Max. Ten. - All forces 250 (lb) or less except when shown.  
 TOP CHORD B-C=-1246/115, C-D=-681/126, D-E=-692/115, E-F=-757/115  
 BOT CHORD B-H=-131/1004, G-H=-132/1001  
 WEBS C-H=0/290, C-G=-606/134, D-G=0/321, E-G=-4/525

**NOTES-**

- Unbalanced roof live loads have been considered for this design.
- Wind: ASCE 7-10; Vult=120mph (3-second gust) Vasd=95mph; TCCL=6.0psf; BCDL=6.0psf; h=30ft; Cat. II; Exp B; Enclosed; MWFRS (envelope) interior zone and C-C Exterior(2) zone; C-C for members and forces & MWFRS for reactions shown; Lumber DOL=1.60 plate grip DOL=1.33
- TCLL: ASCE 7-10; Pr=20.0 psf (roof live load; Lumber DOL=1.15 Plate DOL=1.00); Pg=15.0 psf (ground snow); Pf=10.4 psf (flat roof snow; Lumber DOL=1.15 Plate DOL=1.00); Category II; Exp B; Fully Exp.; Ct=1.10
- Unbalanced snow loads have been considered for this design.
- This truss has been designed for greater of min roof live load of 12.0 psf or 1.00 times flat roof load of 10.4 psf on overhangs non-concurrent with other live loads.
- This truss has been designed for a 10.0 psf bottom chord live load nonconcurrent with any other live loads.
- \* This truss has been designed for a live load of 20.0psf on the bottom chord in all areas where a rectangle 3-6-0 tall by 2-0-0 wide will fit between the bottom chord and any other members.

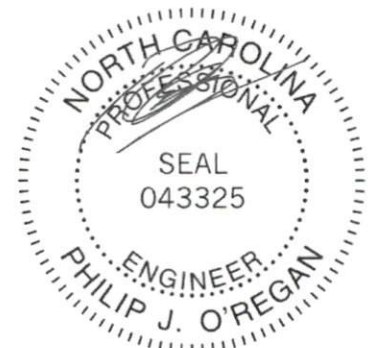

December 4, 2019

**WARNING - Verify design parameters and READ NOTES ON THIS AND INCLUDED MITEK REFERENCE PAGE MII-7473 rev. 10/03/2015 BEFORE USE.**

Design valid for use only with MiTek® connectors. This design is based only upon parameters shown, and is for an individual building component, not a truss system. Before use, the building designer must verify the applicability of design parameters and properly incorporate this design into the overall building design. Bracing indicated is to prevent buckling of individual truss web and/or chord members only. Additional temporary and permanent bracing is always required for stability and to prevent collapse with possible personal injury and property damage. For general guidance regarding the fabrication, storage, delivery, erection and bracing of trusses and truss systems, see **ANSI/TPI1 Quality Criteria, DSB-89 and BCSI Building Component Safety Information** available from Truss Plate Institute, 218 N. Lee Street, Suite 312, Alexandria, VA 22314.



818 Soundside Road  
 Edenton, NC 27932

Job 19-114808T	Truss A05	Truss Type Common Supported Gable	Qty 1	Ply 1	KEN DAWSON PLAN 1341	T18803238
-------------------	--------------	--------------------------------------	----------	----------	----------------------	-----------

BMC (Middlesex, NC), Middlesex, NC - 27557,

8.240 s Jul 14 2019 MiTek Industries, Inc. Tue Dec 3 17:26:43 2019 Page 1

ID:9ohifRTVSugSpHSw?zcUgvyCcmY-spvKcAR0GpE5kOweYhki\_ap2oDbnT7F7vT8U7fyCcDA

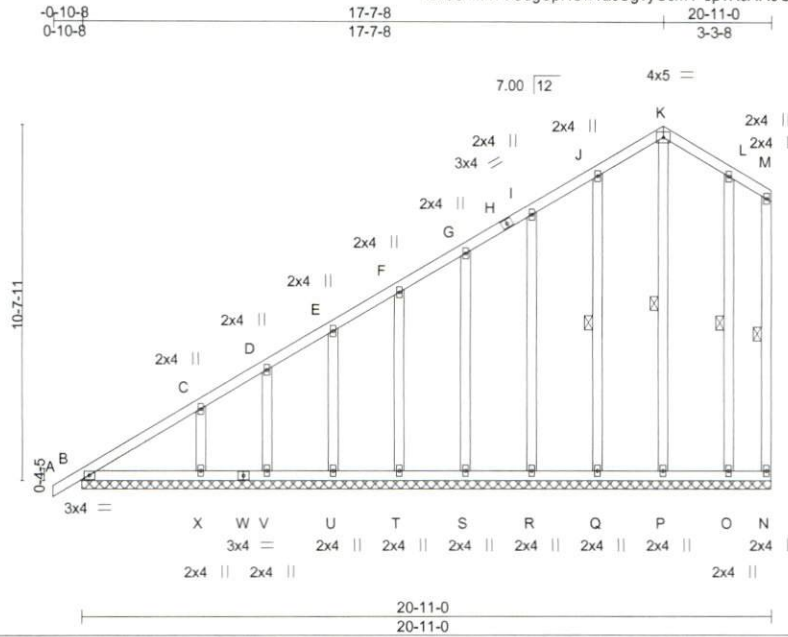

Scale = 1:66.9

<b>LOADING (psf)</b>	<b>SPACING-</b>	<b>CSI.</b>	<b>DEFL.</b>	<b>PLATES</b>	<b>GRIP</b>
TCLL (roof) 20.0	2-0-0	TC 0.14	in (loc) l/defl L/d	MT20	244/190
Snow (Pf/Pg) 10.4/15.0	Plate Grip DOL 1.00	BC 0.09	Vert(LL) -0.00 A n/r 120		
TCDL 10.0	Lumber DOL 1.15	WB 0.15	Vert(CT) 0.00 A n/r 120		
BCLL 0.0 *	Rep Stress Incr YES	Matrix-S	Horz(CT) -0.00 N n/a n/a		
BCDL 10.0	Code IRC2015/TPI2014		Wind(LL) -0.00 A n/r 90	Weight: 166 lb	FT = 20%

**LUMBER-**

TOP CHORD 2x4 SP No.2  
 BOT CHORD 2x4 SP No.2  
 WEBS 2x4 SP No.3  
 OTHERS 2x4 SP No.3

**BRACING-**

TOP CHORD Structural wood sheathing directly applied or 6'-0-0 oc purlins, except end verticals.  
 BOT CHORD Rigid ceiling directly applied or 10'-0-0 oc bracing.  
 WEBS 1 Row at midpt M-N, K-P, J-Q, L-O

**REACTIONS.**

All bearings 20-11-0.  
 (lb) - Max Horz B=319(LC 14)  
 Max Uplift All uplift 100 lb or less at joint(s) N, Q, R, S, T, U, V, X, O  
 Max Grav All reactions 250 lb or less at joint(s) N, B, P, Q, R, S, T, U, V, O except X=291(LC 28)

**FORCES.** (lb) - Max. Comp./Max. Ten. - All forces 250 (lb) or less except when shown.

TOP CHORD B-C=-326/247

**NOTES-**

- Unbalanced roof live loads have been considered for this design.
- Wind: ASCE 7-10; Vult=120mph (3-second gust) Vasd=95mph; TCDL=6.0psf; BCDL=6.0psf; h=30ft; Cat. II; Exp B; Enclosed; MWFRS (envelope) gable end zone and C-C Exterior(2) zone; C-C for members and forces & MWFRS for reactions shown; Lumber DOL=1.60 plate grip DOL=1.33
- Truss designed for wind loads in the plane of the truss only. For studs exposed to wind (normal to the face), see Standard Industry Gable End Details as applicable, or consult qualified building designer as per ANSI/TPI 1.
- TCLL: ASCE 7-10; Pr=20.0 psf (roof live load: Lumber DOL=1.15 Plate DOL=1.00); Pg=15.0 psf (ground snow); Pf=10.4 psf (flat roof snow: Lumber DOL=1.15 Plate DOL=1.00); Category II; Exp B; Fully Exp.; Ct=1.10
- Unbalanced snow loads have been considered for this design.
- This truss has been designed for greater of min roof live load of 12.0 psf or 1.00 times flat roof load of 10.4 psf on overhangs non-concurrent with other live loads.
- Gable requires continuous bottom chord bearing.
- Gable studs spaced at 2-0-0 oc.
- This truss has been designed for a 10.0 psf bottom chord live load nonconcurrent with any other live loads.
- \* This truss has been designed for a live load of 20.0psf on the bottom chord in all areas where a rectangle 3-6-0 tall by 2-0-0 wide will fit between the bottom chord and any other members.
- Provide mechanical connection (by others) of truss to bearing plate capable of withstanding 100 lb uplift at joint(s) N, Q, R, S, T, U, V, X, O.
- Beveled plate or shim required to provide full bearing surface with truss chord at joint(s) B.

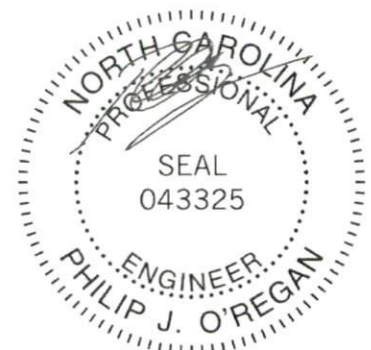

December 4, 2019

**WARNING - Verify design parameters and READ NOTES ON THIS AND INCLUDED MITEK REFERENCE PAGE MII-7473 rev. 10/03/2015 BEFORE USE.**

Design valid for use only with MiTek® connectors. This design is based only upon parameters shown, and is for an individual building component, not a truss system. Before use, the building designer must verify the applicability of design parameters and properly incorporate this design into the overall building design. Bracing indicated is to prevent buckling of individual truss web and/or chord members only. Additional temporary and permanent bracing is always required for stability and to prevent collapse with possible personal injury and property damage. For general guidance regarding the fabrication, storage, delivery, erection and bracing of trusses and truss systems, see **ANSI/TPI1 Quality Criteria, DSB-89 and BCSI Building Component Safety Information** available from Truss Plate Institute, 218 N. Lee Street, Suite 312, Alexandria, VA 22314.

ENGINEERING BY  
**TRENCO**  
 A MiTek Affiliate

818 Soundside Road  
 Edenton, NC 27932

Job 19-114808T	Truss A06	Truss Type Common	Qty 5	Ply 1	KEN DAWSON PLAN 1341	T18803239
					Job Reference (optional)	

BMC (Middlesex, NC),

Middlesex, NC - 27557,

8.240 s Jul 14 2019 MiTek Industries, Inc. Tue Dec 3 17:26:44 2019 Page 1

ID:9chfRTVSugSpHSw?zcUgvyCcmY-K0TiqWSe16MxLYVq6OFxXoMAidrVCZ0H871f6yCcD9

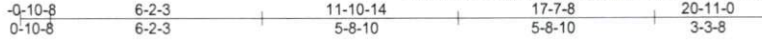

Scale: 3/16"=1'

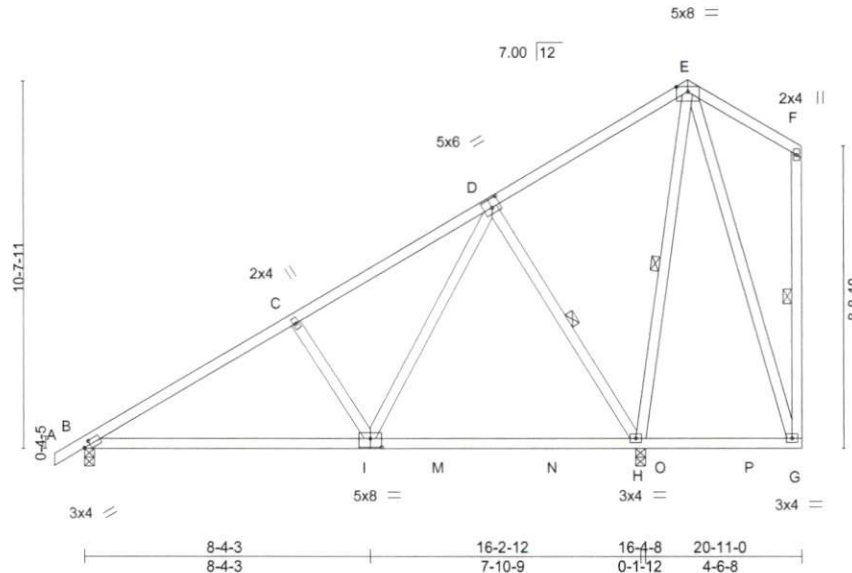

Plate Offsets (X, Y)-- [B:0-2-4,0-1-8], [D:0-3-0,0-3-0], [I:0-4-0,0-3-0]

LOADING (psf)	SPACING-	CSI.	DEFL.	in (loc)	l/defl	L/d	PLATES	GRIP
TCLL (roof) 20.0	2-0-0	TC 0.33	Vert(LL) -0.11	H-I	>999	240	MT20	244/190
Snow (Pf/Pg) 10.4/15.0	Plate Grip DOL 1.00	BC 0.45	Vert(CT) -0.20	I-L	>976	180		
TCDL 10.0	Lumber DOL 1.15	WB 0.24	Horz(CT) 0.01	H	n/a	n/a		
BCLL 0.0	Rep Stress Incr YES	Matrix-MS						
BCDL 10.0	Code IRC2015/TPI2014						Weight: 141 lb	FT = 20%

**LUMBER-**

TOP CHORD 2x4 SP 1650F 1.5E or 2x4 SP No.1 or 2x4 SP SS  
 BOT CHORD 2x4 SP 1650F 1.5E or 2x4 SP No.1 or 2x4 SP SS  
 WEBS 2x4 SP No.3

**BRACING-**

TOP CHORD Structural wood sheathing directly applied or 6-0-0 oc purlins, except end verticals.  
 BOT CHORD Rigid ceiling directly applied or 6-0-0 oc bracing.  
 WEBS 1 Row at midpt D-H, E-H, F-G

**REACTIONS.**

(lb/size) B=490/0-3-8, H=808/0-3-8  
 Max Horz B=218(LC 14)  
 Max Uplift H=-14(LC 14)  
 Max Grav B=674(LC 32), H=1178(LC 28)

**FORCES.**

(lb) - Max. Comp./Max. Ten. - All forces 250 (lb) or less except when shown.  
 TOP CHORD B-C=-834/0, C-D=-671/3  
 BOT CHORD B-I=-165/692, H-I=-75/270  
 WEBS C-I=-328/146, D-I=-31/584, D-H=-635/176, E-H=-429/98

**NOTES-**

- Unbalanced roof live loads have been considered for this design.
- Wind: ASCE 7-10; Vult=120mph (3-second gust) Vasd=95mph; TCDL=6.0psf; BCDL=6.0psf; h=30ft; Cat. II; Exp B; Enclosed; MWFRS (envelope) interior zone and C-C Exterior(2) zone; C-C for members and forces & MWFRS for reactions shown; Lumber DOL=1.60 plate grip DOL=1.33
- TCLL: ASCE 7-10; Pr=20.0 psf (roof live load: Lumber DOL=1.15 Plate DOL=1.00); Pg=15.0 psf (ground snow); Pf=10.4 psf (flat roof snow: Lumber DOL=1.15 Plate DOL=1.00); Category II; Exp B; Fully Exp.; Ct=1.10
- Unbalanced snow loads have been considered for this design.
- This truss has been designed for greater of min roof live load of 12.0 psf or 1.00 times flat roof load of 10.4 psf on overhangs non-concurrent with other live loads.
- This truss has been designed for a 10.0 psf bottom chord live load nonconcurrent with any other live loads.
- \* This truss has been designed for a live load of 20.0psf on the bottom chord in all areas where a rectangle 3-6-0 tall by 2-0-0 wide will fit between the bottom chord and any other members, with BCDL = 10.0psf.
- Provide mechanical connection (by others) of truss to bearing plate capable of withstanding 100 lb uplift at joint(s) H.



December 4, 2019

**WARNING - Verify design parameters and READ NOTES ON THIS AND INCLUDED MITEK REFERENCE PAGE MII-7473 rev. 10/03/2015 BEFORE USE.**

Design valid for use only with MiTek® connectors. This design is based only upon parameters shown, and is for an individual building component, not a truss system. Before use, the building designer must verify the applicability of design parameters and properly incorporate this design into the overall building design. Bracing indicated is to prevent buckling of individual truss web and/or chord members only. Additional temporary and permanent bracing is always required for stability and to prevent collapse with possible personal injury and property damage. For general guidance regarding the fabrication, storage, delivery, erection and bracing of trusses and truss systems, see **ANSI/TPI1 Quality Criteria, DSB-89 and BCSI Building Component Safety Information** available from Truss Plate Institute, 218 N. Lee Street, Suite 312, Alexandria, VA 22314.



818 Soundside Road  
 Edenton, NC 27932

Job 19-114808T	Truss A07	Truss Type Common	Qty 5	Ply 1	KEN DAWSON PLAN 1341	T18803240
-------------------	--------------	----------------------	----------	----------	----------------------	-----------

BMC (Middlesex, NC), Middlesex, NC - 27557,

8.240 s Jul 14 2019 MiTek Industries, Inc. Tue Dec 3 17:26:45 2019 Page 1  
ID:9ohifRTVSugSpHSw?zcUgvyCcmY-oC151sSGoQUozi40g6nA4?vLj1BRxwgQNndaBYyCcD8

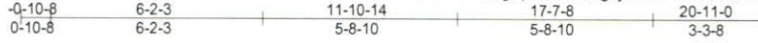

Scale: 3/16"=1'

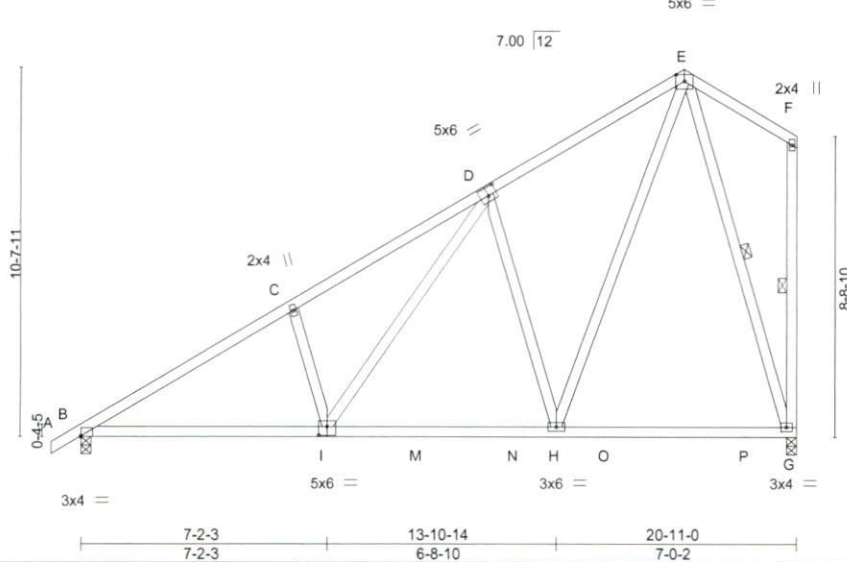

Plate Offsets (X,Y)-- [B:Edge,0-0-4], [D:0-3-0,0-3-0], [I:0-3-0,0-3-0]

<b>LOADING (psf)</b>	<b>SPACING-</b>	<b>CSI.</b>	<b>DEFL.</b>	<b>PLATES</b>	<b>GRIP</b>
TCLL (roof) 20.0	2-0-0	TC 0.31	in (loc) l/defl L/d	MT20	244/190
Snow (Pf/Pg) 10.4/15.0	Plate Grip DOL 1.00	BC 0.40	Vert(LL) -0.10 G-H >999 240		
TCDL 10.0	Lumber DOL 1.15	WB 0.60	Vert(CT) -0.17 G-H >999 180		
BCLL 0.0 *	Rep Stress Incr YES	Matrix-MS	Horz(CT) 0.02 G n/a n/a		
BCDL 10.0	Code IRC2015/TPI2014			Weight: 140 lb	FT = 20%

<b>LUMBER-</b>	<b>BRACING-</b>
TOP CHORD 2x4 SP 1650F 1.5E or 2x4 SP No.1 or 2x4 SP SS	TOP CHORD Structural wood sheathing directly applied or 5-1-14 oc purlins, except end verticals.
BOT CHORD 2x4 SP 1650F 1.5E or 2x4 SP No.1 or 2x4 SP SS	BOT CHORD Rigid ceiling directly applied or 10-0-0 oc bracing.
WEBS 2x4 SP No.3	WEBS 1 Row at midpt F-G, E-G

**REACTIONS.** (lb/size) B=668/0-3-8, G=631/0-3-8  
 Max Horz B=218(LC 14)  
 Max Uplift G=-11(LC 14)  
 Max Grav B=888(LC 28), G=943(LC 28)

**FORCES.** (lb) - Max. Comp./Max. Ten. - All forces 250 (lb) or less except when shown.  
 TOP CHORD B-C=-1285/36, C-D=-1237/108, D-E=-695/113  
 BOT CHORD B-I=-221/1146, H-I=-131/721  
 WEBS C-I=-329/151, D-I=-86/600, D-H=-595/200, E-H=-107/905, E-G=-813/131

- NOTES-**
- 1) Unbalanced roof live loads have been considered for this design.
  - 2) Wind: ASCE 7-10; Vult=120mph (3-second gust) Vasd=95mph; TCDL=6.0psf; BCDL=6.0psf; h=30ft; Cat. II; Exp B; Enclosed; MWFRS (envelope) interior zone and C-C Exterior(2) zone; C-C for members and forces & MWFRS for reactions shown; Lumber DOL=1.60 plate grip DOL=1.33
  - 3) TCLL: ASCE 7-10; Pr=20.0 psf (roof live load: Lumber DOL=1.15 Plate DOL=1.00); Pg=15.0 psf (ground snow); Pf=10.4 psf (flat roof snow: Lumber DOL=1.15 Plate DOL=1.00); Category II; Exp B; Fully Exp.; Ct=1.10
  - 4) Unbalanced snow loads have been considered for this design.
  - 5) This truss has been designed for greater of min roof live load of 12.0 psf or 1.00 times flat roof load of 10.4 psf on overhangs non-concurrent with other live loads.
  - 6) This truss has been designed for a 10.0 psf bottom chord live load nonconcurrent with any other live loads.
  - 7) \* This truss has been designed for a live load of 20.0psf on the bottom chord in all areas where a rectangle 3-6-0 tall by 2-0-0 wide will fit between the bottom chord and any other members, with BCDL = 10.0psf.
  - 8) Provide mechanical connection (by others) of truss to bearing plate capable of withstanding 100 lb uplift at joint(s) G.



December 4, 2019

**WARNING - Verify design parameters and READ NOTES ON THIS AND INCLUDED MITEK REFERENCE PAGE MII-7473 rev. 10/03/2015 BEFORE USE.**

Design valid for use only with MiTek® connectors. This design is based only upon parameters shown, and is for an individual building component, not a truss system. Before use, the building designer must verify the applicability of design parameters and properly incorporate this design into the overall building design. Bracing indicated is to prevent buckling of individual truss web and/or chord members only. Additional temporary and permanent bracing is always required for stability and to prevent collapse with possible personal injury and property damage. For general guidance regarding the fabrication, storage, delivery, erection and bracing of trusses and truss systems, see **ANSI/TPI1 Quality Criteria, DSB-89 and BCSI Building Component Safety Information** available from Truss Plate Institute, 218 N. Lee Street, Suite 312, Alexandria, VA 22314.

**ENGINEERING BY**  
**TRENCO**  
 A MiTek Affiliate

818 Soundside Road  
 Edenton, NC 27932



Job 19-114808T	Truss A08	Truss Type Common	Qty 3	Ply 1	KEN DAWSON PLAN 1341	T18803241
					Job Reference (optional)	

BMC (Middlesex, NC), Middlesex, NC - 27557,

8.240 s Jul 14 2019 MiTek Industries, Inc. Tue Dec 3 17:26:46 2019 Page 1

ID:9ohifRTVSugSPHSw?zclUgvyCcmY-GobTFCTuZkcbsfDDplPcDRUIRU0gNnacRM8k\_yCcD7



Scale = 1:68.7

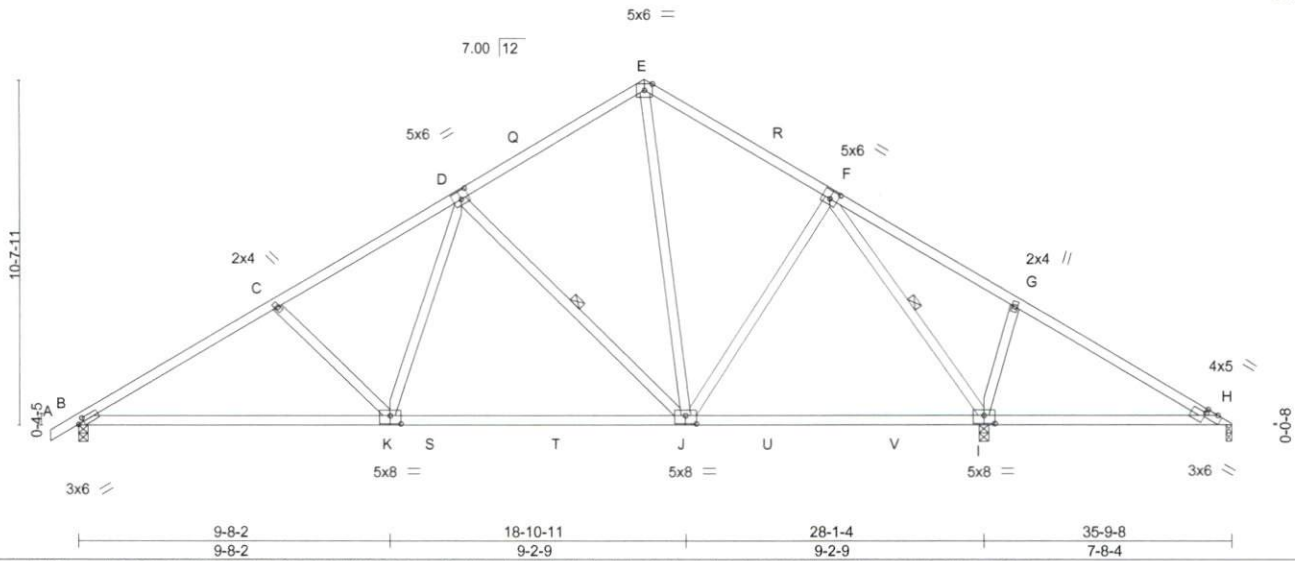

Plate Offsets (X,Y)-- [B:0-2-3,0-1-8], [D:0-3-0,0-3-0], [F:0-3-0,0-3-0], [H:0-4-3,0-1-8], [H:0-4-3,Edge], [I:0-4-0,0-3-0], [J:0-4-0,0-3-0], [K:0-4-0,0-3-0]

LOADING (psf)	SPACING-	CSI.	DEFL.	PLATES	GRIP
TCLL (roof) 20.0	2-0-0	TC 0.42	in (loc) l/defl L/d	MT20	244/190
Snow (Pf/Pg) 10.4/15.0	Plate Grip DOL 1.00	BC 0.64	Vert(LL) -0.19 I-J >999 240		
TCDL 10.0	Lumber DOL 1.15	WB 0.61	Vert(CT) -0.36 K-N >940 180		
BCLL 0.0	Rep Stress Incr YES	Matrix-MS	Horz(CT) 0.04 H n/a n/a		
BCDL 10.0	Code IRC2015/TPI2014			Weight: 192 lb	FT = 20%

**LUMBER-**  
 TOP CHORD 2x4 SP 1650F 1.5E or 2x4 SP No.1 or 2x4 SP SS  
 BOT CHORD 2x4 SP 1650F 1.5E or 2x4 SP No.1 or 2x4 SP SS  
 WEBS 2x4 SP No.3

**BRACING-**  
 TOP CHORD Structural wood sheathing directly applied or 4-4-10 oc purlins.  
 BOT CHORD Rigid ceiling directly applied or 10-0-0 oc bracing, Except:  
 WEBS 6-0-0 oc bracing: H-I, 1 Row at midpt D-J, F-I

**REACTIONS.** (lb/size) B=830/0-3-8, I=1368/0-3-8, H=8/0-2-0  
 Max Horz B=181(LC 13)  
 Max Uplift H=-47(LC 32)  
 Max Grav B=1105(LC 28), I=1807(LC 29), H=63(LC 33)

**FORCES.** (lb) - Max. Comp./Max. Ten. - All forces 250 (lb) or less except when shown.  
 TOP CHORD B-C=-1685/180, C-D=-1471/177, D-E=-744/177, E-F=-817/186, F-G=-26/623,  
 G-H=-100/540  
 BOT CHORD B-K=-75/1539, J-K=0/1135, I-J=0/445, H-I=-406/135  
 WEBS C-K=-345/146, D-K=0/548, D-J=-707/158, E-J=-66/430, F-J=0/435, F-I=-1517/163,  
 G-I=-348/157

- NOTES-**
- Unbalanced roof live loads have been considered for this design.
  - Wind: ASCE 7-10; Vult=120mph (3-second gust) Vasd=95mph; TCCL=6.0psf; BCCL=6.0psf; h=30ft; Cat. II; Exp B; Enclosed; MWFRS (envelope) interior zone and C-C Exterior(2) zone; C-C for members and forces & MWFRS for reactions shown; Lumber DOL=1.60 plate grip DOL=1.33
  - TCLL: ASCE 7-10; Pr=20.0 psf (roof live load: Lumber DOL=1.15 Plate DOL=1.00); Pg=15.0 psf (ground snow); Pf=10.4 psf (flat roof snow: Lumber DOL=1.15 Plate DOL=1.00); Category II; Exp B; Fully Exp.; Ct=1.10
  - Unbalanced snow loads have been considered for this design.
  - This truss has been designed for greater of min roof live load of 12.0 psf or 1.00 times flat roof load of 10.4 psf on overhangs non-concurrent with other live loads.
  - This truss has been designed for a 10.0 psf bottom chord live load nonconcurrent with any other live loads.
  - \* This truss has been designed for a live load of 20.0psf on the bottom chord in all areas where a rectangle 3-6-0 tall by 2-0-0 wide will fit between the bottom chord and any other members, with BCCL = 10.0psf.
  - Provide mechanical connection (by others) of truss to bearing plate at joint(s) H.
  - Provide mechanical connection (by others) of truss to bearing plate capable of withstanding 100 lb uplift at joint(s) H.



December 4, 2019

**WARNING - Verify design parameters and READ NOTES ON THIS AND INCLUDED MITEK REFERENCE PAGE MII-7473 rev. 10/03/2015 BEFORE USE.**

Design valid for use only with MiTek® connectors. This design is based only upon parameters shown, and is for an individual building component, not a truss system. Before use, the building designer must verify the applicability of design parameters and properly incorporate this design into the overall building design. Bracing indicated is to prevent buckling of individual truss web and/or chord members only. Additional temporary and permanent bracing is always required for stability and to prevent collapse with possible personal injury and property damage. For general guidance regarding the fabrication, storage, delivery, erection and bracing of trusses and truss systems, see **ANSI/TPI1 Quality Criteria, DSB-89 and BCSI Building Component Safety Information** available from Truss Plate Institute, 218 N. Lee Street, Suite 312, Alexandria, VA 22314.

ENGINEERING BY  
**TRENCO**  
 A MiTek Affiliate

818 Soundside Road  
 Edenton, NC 27932

Job	Truss	Truss Type	Qty	Ply	KEN DAWSON PLAN 1341	T18803242
19-114808T	A09	Common	5	1		

BMC (Middlesex, NC), Middlesex, NC - 27557, 8.240 s Jul 14 2019 MiTek Industries, Inc. Tue Dec 3 17:26:48 2019 Page 1  
 ID:9ohifRTVSpSugPHSw?zcUgvyCcmY-DniDguV95LsNq9pbLEKtheXqWE8D8HHt3rFotyCcD5  
 Job Reference (optional)

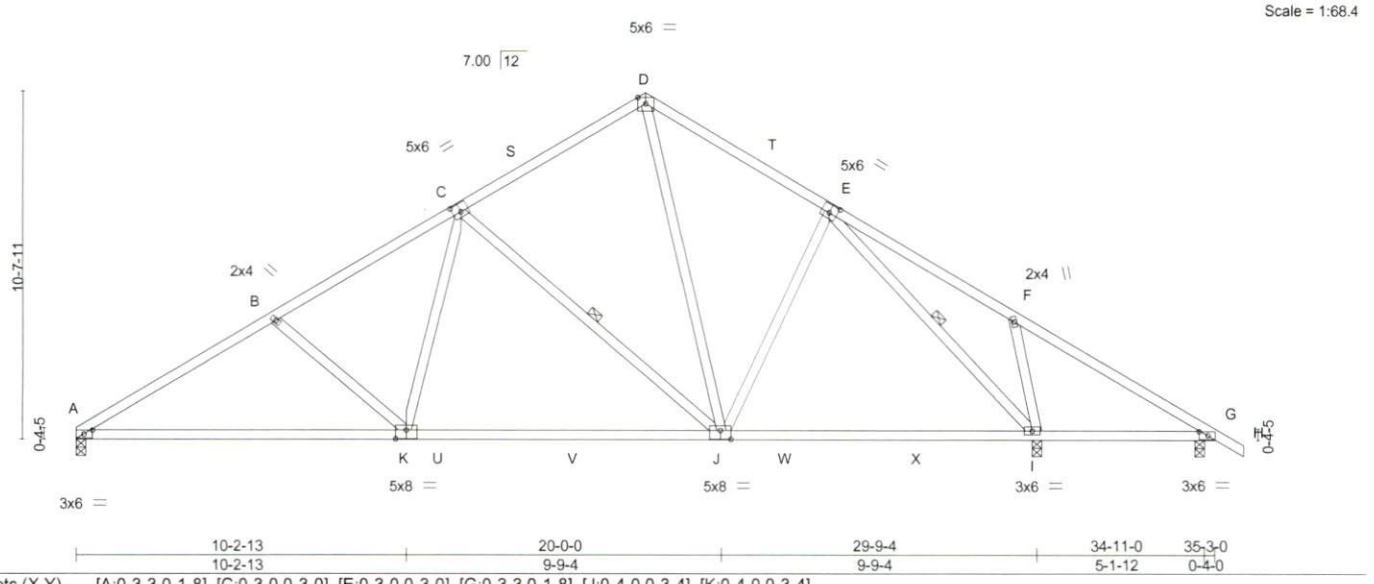

Plate Offsets (X, Y)--	[A:0-3-3,0-1-8], [C:0-3-0,0-3-0], [E:0-3-0,0-3-0], [G:0-3-3,0-1-8], [J:0-4-0,0-3-4], [K:0-4-0,0-3-4]
------------------------	--

<b>LOADING (psf)</b>	<b>SPACING-</b>	<b>CSI.</b>	<b>DEFL.</b>	<b>PLATES</b>	<b>GRIP</b>
TCLL (roof) 20.0	2-0-0	TC 0.40	in (loc) l/defl L/d	MT20	244/190
Snow (Pf/Pg) 10.4/15.0	Plate Grip DOL 1.00	BC 0.72	Vert(LL) -0.22 I-J >999 240		
TCDL 10.0	Lumber DOL 1.15	WB 0.61	Vert(CT) -0.44 K-N >805 180		
BCLL 0.0 *	Rep Stress Incr YES	Matrix-MS	Horz(CT) 0.05 I n/a n/a		
BCDL 10.0	Code IRC2015/TPI2014			Weight: 194 lb	FT = 20%

<b>LUMBER-</b>	<b>BRACING-</b>
TOP CHORD 2x4 SP 1650F 1.5E or 2x4 SP No.1 or 2x4 SP SS	TOP CHORD Structural wood sheathing directly applied or 3-11-14 oc purlins.
BOT CHORD 2x4 SP 1650F 1.5E or 2x4 SP No.1 or 2x4 SP SS	BOT CHORD Rigid ceiling directly applied or 10-0-0 oc bracing, Except:
WEBS 2x4 SP No.3	6-0-0 oc bracing: G-I.
	1 Row at midpt C-J, E-I

<b>REACTIONS.</b>	(lb/size) A=894/0-3-8, I=1135/0-3-8, G=150/0-3-8
	Max Horz A=-224(LC 12)
	Max Uplift A=-73(LC 14), I=-29(LC 15), G=-64(LC 15)
	Max Grav A=1179(LC 28), I=1546(LC 29), G=256(LC 33)

<b>FORCES.</b>	(lb) - Max. Comp./Max. Ten. - All forces 250 (lb) or less except when shown.
TOP CHORD	A-B=-1916/227, B-C=-1670/213, C-D=-939/211, D-E=-1089/239
BOT CHORD	A-K=-195/1775, J-K=-73/1376, I-J=0/853
WEBS	B-K=-363/163, C-K=0/553, C-J=-765/177, D-J=-113/683, E-I=-1328/14, F-I=-429/219

- NOTES-**
- 1) Unbalanced roof live loads have been considered for this design.
  - 2) Wind: ASCE 7-10; Vult=120mph (3-second gust) Vasd=95mph; TCDL=6.0psf; BCDL=6.0psf; h=30ft; Cat. II; Exp B; Enclosed; MWFRS (envelope) gable end zone and C-C Exterior(2) zone; C-C for members and forces & MWFRS for reactions shown; Lumber DOL=1.60 plate grip DOL=1.33
  - 3) TCLL: ASCE 7-10; Pr=20.0 psf (roof live load: Lumber DOL=1.15 Plate DOL=1.00); Pg=15.0 psf (ground snow); Pf=10.4 psf (flat roof snow: Lumber DOL=1.15 Plate DOL=1.00); Category II; Exp B; Fully Exp.; Ct=1.10
  - 4) Unbalanced snow loads have been considered for this design.
  - 5) This truss has been designed for greater of min roof live load of 12.0 psf or 1.00 times flat roof load of 10.4 psf on overhangs non-concurrent with other live loads.
  - 6) This truss has been designed for a 10.0 psf bottom chord live load nonconcurrent with any other live loads.
  - 7) \* This truss has been designed for a live load of 20.0psf on the bottom chord in all areas where a rectangle 3-6-0 tall by 2-0-0 wide will fit between the bottom chord and any other members, with BCDL = 10.0psf.
  - 8) Provide mechanical connection (by others) of truss to bearing plate capable of withstanding 100 lb uplift at joint(s) A, I, G.

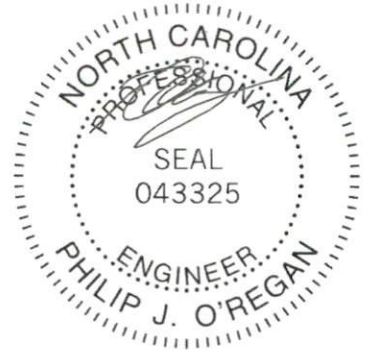

December 4, 2019

<p><b>WARNING - Verify design parameters and READ NOTES ON THIS AND INCLUDED MITEK REFERENCE PAGE MII-7473 rev. 10/03/2015 BEFORE USE.</b></p> <p>Design valid for use only with MiTek® connectors. This design is based only upon parameters shown, and is for an individual building component, not a truss system. Before use, the building designer must verify the applicability of design parameters and properly incorporate this design into the overall building design. Bracing indicated is to prevent buckling of individual truss web and/or chord members only. Additional temporary and permanent bracing is always required for stability and to prevent collapse with possible personal injury and property damage. For general guidance regarding the fabrication, storage, delivery, erection and bracing of trusses and truss systems, see <b>ANSI/TPI1 Quality Criteria, DSB-89 and BCSI Building Component Safety Information</b> available from Truss Plate Institute, 218 N. Lee Street, Suite 312, Alexandria, VA 22314.</p>	<p>ENGINEERING BY</p> <p><b>TRENCO</b></p> <p>A MiTek Affiliate</p> <p>818 Soundside Road Edenton, NC 27932</p>
---	---

Job 19-114808T	Truss A10	Truss Type Common	Qty 2	Ply 1	KEN DAWSON PLAN 1341	T18803243
					Job Reference (optional)	

BMC (Middlesex, NC), Middlesex, NC - 27557,

8.240 s Jul 14 2019 MiTek Industries, Inc. Tue Dec 3 17:26:49 2019 Page 1

ID:9ohifRTVgSugSpHsw?zcUgvyCcmY-hzGbtEWnsf\_ESJOovyr6Er30heWmtmf0IPboKJyCcD4

0-10-8	6-2-3	11-10-14	17-7-8	23-4-2	29-0-13	35-3-0	36-1-8
0-10-8	6-2-3	5-8-10	5-8-10	5-8-10	5-8-10	6-2-3	0-10-8

Scale = 1:68.9

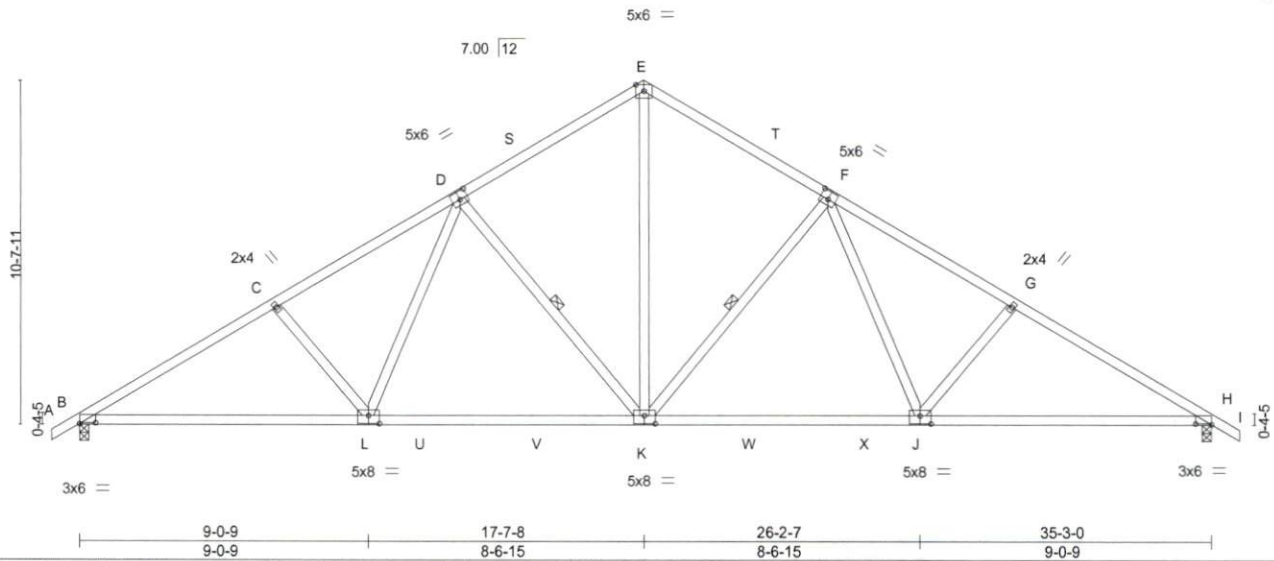

Plate Offsets (X,Y)-- [B:0-6-0,0-0-6], [D:0-3-0,0-3-0], [F:0-3-0,0-3-0], [H:0-6-0,0-0-6], [J:0-4-0,0-3-0], [K:0-4-0,0-3-0], [L:0-4-0,0-3-0]

LOADING (psf)	SPACING-	CSI.	DEFL.	PLATES	GRIP
TCLL (roof) 20.0	2-0-0	TC 0.37	in (loc) l/defl L/d	MT20	244/190
Snow (Pf/Pg) 10.4/15.0	Plate Grip DOL 1.00	BC 0.63	Vert(LL) -0.20 J-K >999 240		
TCDL 10.0	Lumber DOL 1.15	WB 0.48	Vert(CT) -0.35 J-K >999 180		
BCLL 0.0	Rep Stress Incr YES	Matrix-MS	Horz(CT) 0.09 H n/a n/a		
BCDL 10.0	Code IRC2015/TP12014			Weight: 192 lb	FT = 20%

**LUMBER-**

TOP CHORD 2x4 SP 1650F 1.5E or 2x4 SP No.1 or 2x4 SP SS  
 BOT CHORD 2x4 SP 1650F 1.5E or 2x4 SP No.1 or 2x4 SP SS  
 WEBS 2x4 SP No.3

**BRACING-**

TOP CHORD Structural wood sheathing directly applied or 3-7-11 oc purlins.  
 BOT CHORD Rigid ceiling directly applied or 10-0-0 oc bracing.  
 WEBS 1 Row at midpt F-K, D-K

**REACTIONS.**

(lb/size) B=1107/0-3-8, H=1107/0-3-8  
 Max Horz B=-227(LC 12)  
 Max Uplift B=-88(LC 14), H=-88(LC 15)  
 Max Grav B=1462(LC 2), H=1463(LC 2)

**FORCES.**

(lb) - Max. Comp./Max. Ten. - All forces 250 (lb) or less except when shown.  
 TOP CHORD B-C=-2370/252, C-D=-2190/264, D-E=-1519/265, E-F=-1519/265, F-G=-2190/264, G-H=-2371/252  
 BOT CHORD B-L=-187/2162, K-L=-78/1743, J-K=-24/1627, H-J=-119/2000  
 WEBS E-K=-151/1164, F-K=-673/189, F-J=-22/556, G-J=-333/159, D-K=-673/189, D-L=-22/556, C-L=-333/159

**NOTES-**

- Unbalanced roof live loads have been considered for this design.
- Wind: ASCE 7-10; Vult=120mph (3-second gust) Vasd=95mph; TCDL=6.0psf; BCDL=6.0psf; h=30ft; Cat. II; Exp B; Enclosed; MWFRS (envelope) gable end zone and C-C Exterior(2) zone; C-C for members and forces & MWFRS for reactions shown; Lumber DOL=1.60 plate grip DOL=1.33
- TCLL: ASCE 7-10; Pr=20.0 psf (roof live load: Lumber DOL=1.15 Plate DOL=1.00); Pg=15.0 psf (ground snow); Pf=10.4 psf (flat roof snow: Lumber DOL=1.15 Plate DOL=1.00); Category II; Exp B; Fully Exp.; Ct=1.10
- Unbalanced snow loads have been considered for this design.
- This truss has been designed for greater of min roof live load of 12.0 psf or 1.00 times flat roof load of 10.4 psf on overhangs non-concurrent with other live loads.
- This truss has been designed for a 10.0 psf bottom chord live load nonconcurrent with any other live loads.
- \* This truss has been designed for a live load of 20.0psf on the bottom chord in all areas where a rectangle 3-6-0 tall by 2-0-0 wide will fit between the bottom chord and any other members, with BCDL = 10.0psf.
- Provide mechanical connection (by others) of truss to bearing plate capable of withstanding 100 lb uplift at joint(s) B, H.

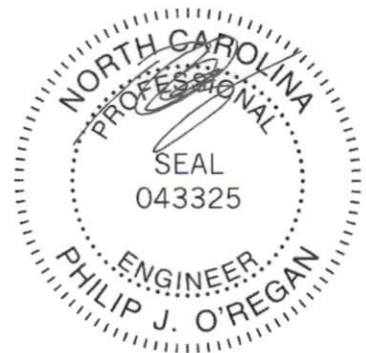

December 4, 2019

**WARNING - Verify design parameters and READ NOTES ON THIS AND INCLUDED MITEK REFERENCE PAGE MII-7473 rev. 10/03/2015 BEFORE USE.**

Design valid for use only with MiTek® connectors. This design is based only upon parameters shown, and is for an individual building component, not a truss system. Before use, the building designer must verify the applicability of design parameters and properly incorporate this design into the overall building design. Bracing indicated is to prevent buckling of individual truss web and/or chord members only. Additional temporary and permanent bracing is always required for stability and to prevent collapse with possible personal injury and property damage. For general guidance regarding the fabrication, storage, delivery, erection and bracing of trusses and truss systems, see **ANSI/TP1 Quality Criteria, DSB-89 and BCSI Building Component Safety Information** available from Truss Plate Institute, 218 N. Lee Street, Suite 312, Alexandria, VA 22314.

ENGINEERING BY  
**TRENCO**  
 A MiTek Affiliate

818 Soundside Road  
 Edenton, NC 27932

Job 19-114808T	Truss A11	Truss Type Common	Qty 4	Ply 1	KEN DAWSON PLAN 1341	T18803244
-------------------	--------------	----------------------	----------	----------	----------------------	-----------

BMC (Middlesex, NC), Middlesex, NC - 27557, 8.240 s Jul 14 2019 MiTek Industries, Inc. Tue Dec 3 17:26:51 2019 Page 1  
 ID:9ohifRTVSugSpHSw?zcUgvyCcmY-dMOMlwX1OGEyhdXA0MtaJG9LySBCLg8Jj4vPCyCcD2  
 6-2-3 11-10-14 17-7-8 23-4-2 29-0-13 35-3-0 36-1-8  
 6-2-3 5-8-10 5-8-10 5-8-10 5-8-10 6-2-3 0-10-8

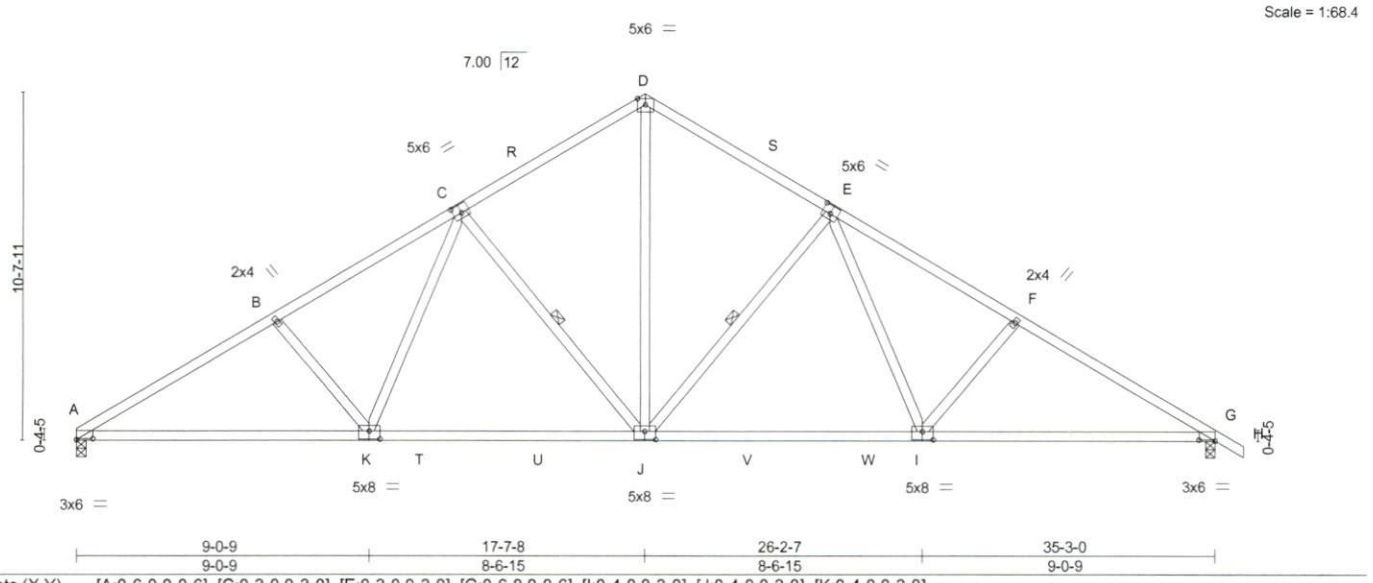

Plate Offsets (X, Y)-- [A:0-6-0,0-0-6], [C:0-3-0,0-3-0], [E:0-3-0,0-3-0], [G:0-6-0,0-0-6], [I:0-4-0,0-3-0], [J:0-4-0,0-3-0], [K:0-4-0,0-3-0]

<b>LOADING (psf)</b>	<b>SPACING-</b>	<b>CSI.</b>	<b>DEFL.</b>	<b>PLATES</b>	<b>GRIP</b>
TCLL (roof) 20.0	2-0-0	TC 0.39	in (loc) l/defl L/d	MT20	244/190
Snow (Pf/Pg) 10.4/15.0	Plate Grip DOL 1.00	BC 0.63	Vert(LL) -0.20 I-J >999 240		
TCDL 10.0	Lumber DOL 1.15	WB 0.48	Vert(CT) -0.35 I-J >999 180		
BCLL 0.0 *	Rep Stress Incr YES	Matrix-MS	Horz(CT) 0.09 G n/a n/a		
BCDL 10.0	Code IRC2015/TPI2014			Weight: 191 lb	FT = 20%

**LUMBER-**  
 TOP CHORD 2x4 SP 1650F 1.5E or 2x4 SP No.1 or 2x4 SP SS  
 BOT CHORD 2x4 SP 1650F 1.5E or 2x4 SP No.1 or 2x4 SP SS  
 WEBS 2x4 SP No.3

**BRACING-**  
 TOP CHORD Structural wood sheathing directly applied or 3-7-5 oc purlins.  
 BOT CHORD Rigid ceiling directly applied or 10-0-0 oc bracing.  
 WEBS 1 Row at midpt E-J, C-J

**REACTIONS.** (lb/size) A=1071/0-3-8, G=1108/0-3-8  
 Max Horz A=-224(LC 12)  
 Max Uplift A=-73(LC 14), G=-88(LC 15)  
 Max Grav A=1409(LC 2), G=1463(LC 2)

**FORCES.** (lb) - Max. Comp./Max. Ten. - All forces 250 (lb) or less except when shown.  
 TOP CHORD A-B=-2375/256, B-C=-2194/268, C-D=-1520/266, D-E=-1520/266, E-F=-2191/265, F-G=-2371/253  
 BOT CHORD A-K=-190/2167, J-K=-79/1745, I-J=-25/1629, G-I=-120/2001  
 WEBS D-J=-151/1165, E-J=-673/189, E-I=-22/556, F-I=-333/159, C-J=-675/190, C-K=-24/560, B-K=-336/160

- NOTES-**
- Unbalanced roof live loads have been considered for this design.
  - Wind: ASCE 7-10; Vult=120mph (3-second gust) Vasd=95mph; TCDL=6.0psf; BCDL=6.0psf; h=30ft; Cat. II; Exp B; Enclosed; MWFRS (envelope) gable end zone and C-C Exterior(2) zone; C-C for members and forces & MWFRS for reactions shown; Lumber DOL=1.60 plate grip DOL=1.33
  - TCLL: ASCE 7-10; Pr=20.0 psf (roof live load: Lumber DOL=1.15 Plate DOL=1.00); Pg=15.0 psf (ground snow); Pf=10.4 psf (flat roof snow: Lumber DOL=1.15 Plate DOL=1.00); Category II; Exp B; Fully Exp.; Ct=1.10
  - Unbalanced snow loads have been considered for this design.
  - This truss has been designed for greater of min roof live load of 12.0 psf or 1.00 times flat roof load of 10.4 psf on overhangs non-concurrent with other live loads.
  - This truss has been designed for a 10.0 psf bottom chord live load nonconcurrent with any other live loads.
  - \* This truss has been designed for a live load of 20.0psf on the bottom chord in all areas where a rectangle 3-6-0 tall by 2-0-0 wide will fit between the bottom chord and any other members, with BCDL = 10.0psf.
  - Provide mechanical connection (by others) of truss to bearing plate capable of withstanding 100 lb uplift at joint(s) A, G.



December 4, 2019

Job 19-114808T	Truss A12	Truss Type Common Supported Gable	Qty 1	Ply 1	KEN DAWSON PLAN 1341	T18803245
BMC (Middlesex, NC), Middlesex, NC - 27557,					Job Reference (optional)	

8.240 s Jul 14 2019 MiTek Industries, Inc. Tue Dec 3 17:26:52 2019 Page 1  
 ID:9chifRTVSugSpHSw?zcUgvyCcmY-5YkVFYf9aMpJn6Na4PpsUhaRsfm4CSS\_NpSxeyCcD1

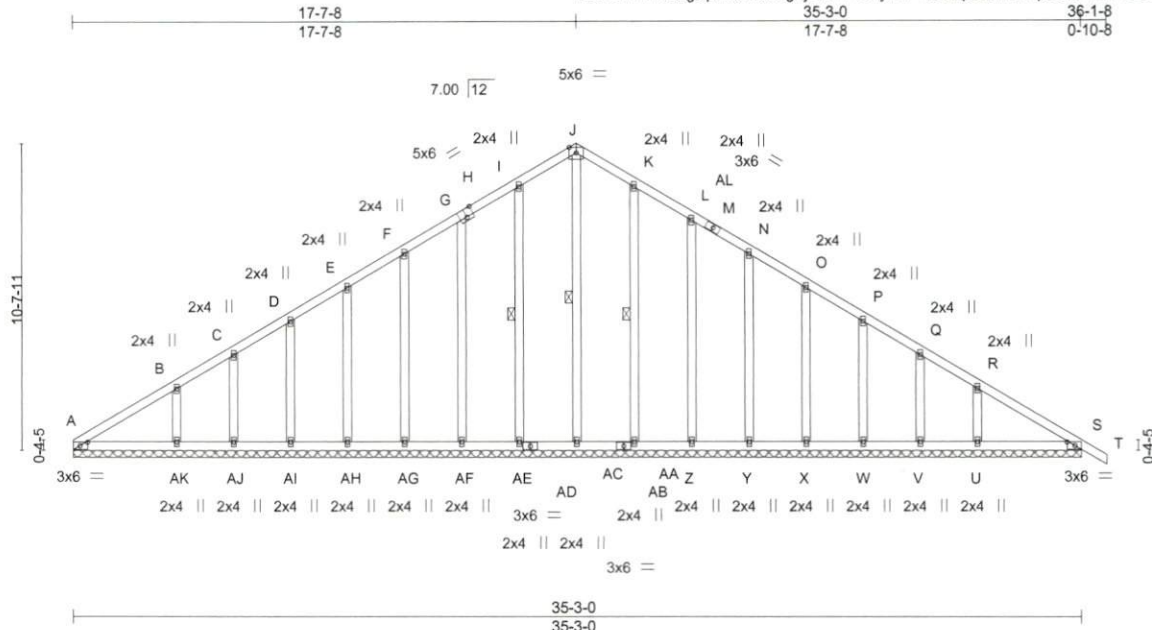

Plate Offsets (X,Y)-- [A:0-3-3,0-1-8], [G:0-2-0,0-0-0], [H:0-0-0,0-1-12], [H:0-3-0,Edge], [S:0-3-3,0-1-8]

LOADING (psf)	SPACING-	CSI.	DEFL.	in (loc)	l/defl	L/d	PLATES	GRIP
TCLL (roof) 20.0	2-0-0	TC 0.15	Vert(LL) 0.00	T	n/r	120	MT20	244/190
Snow (Pf/Pg) 10.4/15.0	Plate Grip DOL 1.00	BC 0.10	Vert(CT) 0.01	T	n/r	120		
TCDL 10.0	Lumber DOL 1.15	WB 0.15	Horz(CT) 0.01	S	n/a	n/a		
BCLL 0.0	Rep Stress Incr YES	Matrix-S	Wind(LL) 0.00	S	n/r	90		
BCDL 10.0	Code IRC2015/TPI2014						Weight: 243 lb	FT = 20%

LUMBER-	BRACING-
TOP CHORD 2x4 SP No.2	TOP CHORD Structural wood sheathing directly applied or 6-0-0 oc purlins.
BOT CHORD 2x4 SP No.2	BOT CHORD Rigid ceiling directly applied or 10-0-0 oc bracing.
OTHERS 2x4 SP No.3	WEBS 1 Row at midpt J-AC, I-AE, K-AA

**REACTIONS.** All bearings 35-3-0.  
 (lb) - Max Horz A=-224(LC 10)  
 Max Uplift All uplift 100 lb or less at joint(s) A, AE, AF, AG, AH, AI, AJ, AK, AA, Z, Y, X, W, V, U  
 Max Grav All reactions 250 lb or less at joint(s) A, AC, AE, AF, AG, AH, AI, AJ, AA, Z, Y, X, W, V, S except AK=304(LC 28), U=290(LC 29)

**FORCES.** (lb) - Max. Comp./Max. Ten. - All forces 250 (lb) or less except when shown.

- NOTES-**
- Unbalanced roof live loads have been considered for this design.
  - Wind: ASCE 7-10; Vult=120mph (3-second gust) Vasd=95mph; TCDL=6.0psf; BCDL=6.0psf; h=30ft; Cat. II; Exp B; Enclosed; MWFRS (envelope) gable end zone and C-C Exterior(2) zone; C-C for members and forces & MWFRS for reactions shown; Lumber DOL=1.60 plate grip DOL=1.33
  - Truss designed for wind loads in the plane of the truss only. For studs exposed to wind (normal to the face), see Standard Industry Gable End Details as applicable, or consult qualified building designer as per ANSI/TPI 1.
  - TCLL: ASCE 7-10; Pr=20.0 psf (roof live load: Lumber DOL=1.15 Plate DOL=1.00); Pg=15.0 psf (ground snow); Pf=10.4 psf (flat roof snow: Lumber DOL=1.15 Plate DOL=1.00); Category II; Exp B; Fully Exp.; Ct=1.10
  - Unbalanced snow loads have been considered for this design.
  - This truss has been designed for greater of min roof live load of 12.0 psf or 1.00 times flat roof load of 10.4 psf on overhangs non-concurrent with other live loads.
  - Gable requires continuous bottom chord bearing.
  - Gable studs spaced at 2-0-0 oc.
  - This truss has been designed for a 10.0 psf bottom chord live load nonconcurrent with any other live loads.
  - \* This truss has been designed for a live load of 20.0psf on the bottom chord in all areas where a rectangle 3-6-0 tall by 2-0-0 wide will fit between the bottom chord and any other members.
  - Provide mechanical connection (by others) of truss to bearing plate capable of withstanding 100 lb uplift at joint(s) A, AE, AF, AG, AH, AI, AJ, AK, AA, Z, Y, X, W, V, U.
  - Beveled plate or shim required to provide full bearing surface with truss chord at joint(s) A, S.

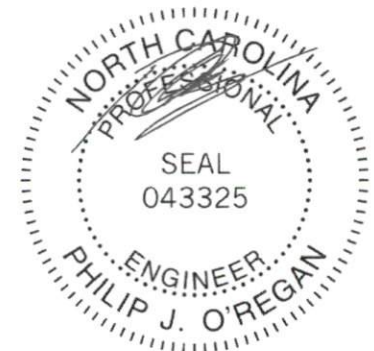

December 4, 2019

Job 19-114808T	Truss V01	Truss Type Valley	Qty 1	Ply 1	KEN DAWSON PLAN 1341	T18803246
BMC (Middlesex, NC), Middlesex, NC - 27557,		8.240 s Jul 14 2019 MiTek Industries, Inc. Tue Dec 3 17:26:53 2019 Page 1				
		ID:9ohifRTV SugSpHSw?zUgvyCcmY-ZkW6jbZHwtUgwxhZ8nw2OhEKRF?hphFcD1Z0T4yCcD0				
						Job Reference (optional)

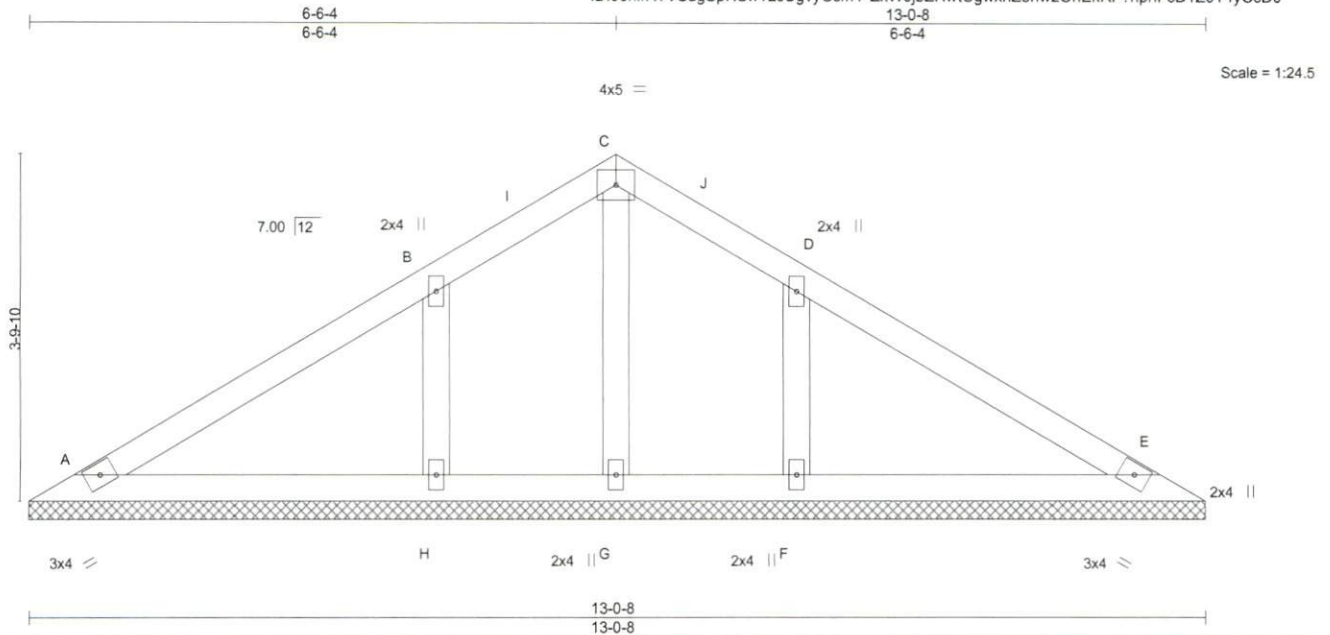

<b>LOADING (psf)</b>	<b>SPACING-</b>	<b>CSI.</b>	<b>DEFL.</b>	<b>PLATES</b>	<b>GRIP</b>
TCLL (roof) 20.0	2-0-0	TC 0.20	in (loc) l/defl L/d	MT20	244/190
Snow (Pf/Pg) 10.4/15.0	Plate Grip DOL 1.00	BC 0.12	Vert(LL) n/a - n/a 999		
TCDL 10.0	Lumber DOL 1.15	WB 0.05	Vert(CT) n/a - n/a 999		
BCLL 0.0 *	Rep Stress Incr YES	Matrix-S	Horz(CT) 0.00 E n/a n/a		
BCDL 10.0	Code IRC2015/TPI2014			Weight: 51 lb	FT = 20%

<b>LUMBER-</b>	<b>BRACING-</b>
TOP CHORD 2x4 SP No.2	TOP CHORD Structural wood sheathing directly applied or 6-0-0 oc purlins.
BOT CHORD 2x4 SP No.2	BOT CHORD Rigid ceiling directly applied or 10-0-0 oc bracing.
OTHERS 2x4 SP No.3	

**REACTIONS.** All bearings 13-0-8.  
 (lb) - Max Horz A=-74(LC 10)  
 Max Uplift All uplift 100 lb or less at joint(s) A, E, G, H, F  
 Max Grav All reactions 250 lb or less at joint(s) A, E, G except H=343(LC 27), F=343(LC 28)

**FORCES.** (lb) - Max. Comp./Max. Ten. - All forces 250 (lb) or less except when shown.

- NOTES-**
- Unbalanced roof live loads have been considered for this design.
  - Wind: ASCE 7-10; Vult=120mph (3-second gust) Vasd=95mph; TCDL=6.0psf; BCDL=6.0psf; h=30ft; Cat. II; Exp B; Enclosed; MWFRS (envelope) gable end zone and C-C Exterior(2) zone; C-C for members and forces & MWFRS for reactions shown; Lumber DOL=1.60 plate grip DOL=1.33
  - Truss designed for wind loads in the plane of the truss only. For studs exposed to wind (normal to the face), see Standard Industry Gable End Details as applicable, or consult qualified building designer as per ANSI/TPI 1.
  - TCLL: ASCE 7-10; Pr=20.0 psf (roof live load: Lumber DOL=1.15 Plate DOL=1.00); Pg=15.0 psf (ground snow); Pf=10.4 psf (flat roof snow: Lumber DOL=1.15 Plate DOL=1.00); Category II; Exp B; Fully Exp.; Ct=1.10
  - Unbalanced snow loads have been considered for this design.
  - Gable requires continuous bottom chord bearing.
  - Gable studs spaced at 2-0-0 oc.
  - This truss has been designed for a 10.0 psf bottom chord live load nonconcurrent with any other live loads.
  - \* This truss has been designed for a live load of 20.0psf on the bottom chord in all areas where a rectangle 3-6-0 tall by 2-0-0 wide will fit between the bottom chord and any other members.
  - Provide mechanical connection (by others) of truss to bearing plate capable of withstanding 100 lb uplift at joint(s) A, E, G, H, F.



December 4, 2019

Job 19-114808T	Truss V02	Truss Type Valley	Qty 1	Ply 1	KEN DAWSON PLAN 1341	T18803247
BMC (Middlesex, NC), Middlesex, NC - 27557,					8.240 s Jul 14 2019 MiTek Industries, Inc. Tue Dec 3 17:26:54 2019 Page 1	
					Job Reference (optional)	
					ID:9ohifRTVSugSpHSw?zcUgvyCcmY-1x4UwxZwhBdXY4GihVRHxnuXfkJY8dlRgIZ0XyCcD?	

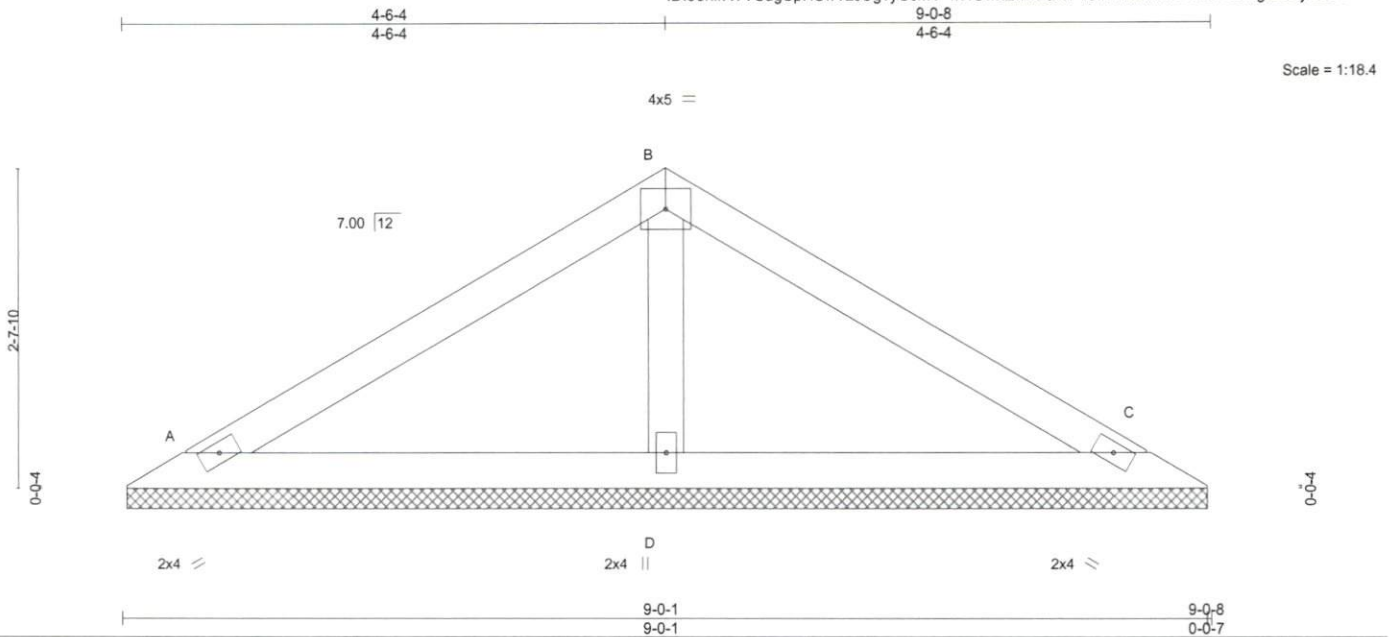

LOADING (psf)	SPACING-	CSI.	DEFL.	PLATES	GRIP
TCLL (roof) 20.0	2-0-0	TC 0.30	in (loc) l/defl L/d	MT20	244/190
Snow (Pf/Pg) 10.4/15.0	Plate Grip DOL 1.00	BC 0.16	Vert(LL) n/a - n/a 999		
TCDL 10.0	Lumber DOL 1.15	WB 0.04	Vert(CT) n/a - n/a 999		
BCLL 0.0	Rep Stress Incr YES	Matrix-P	Horz(CT) 0.00 C n/a n/a		
BCDL 10.0	Code IRC2015/TPI2014			Weight: 30 lb	FT = 20%

LUMBER-	BRACING-
TOP CHORD 2x4 SP No.2	TOP CHORD Structural wood sheathing directly applied or 6-0-0 oc purlins.
BOT CHORD 2x4 SP No.2	BOT CHORD Rigid ceiling directly applied or 10-0-0 oc bracing.
OTHERS 2x4 SP No.3	

**REACTIONS.** (lb/size) A=123/8-11-10, C=123/8-11-10, D=238/8-11-10  
 Max Horz A=-49(LC 10)  
 Max Uplift A=-26(LC 14), C=-32(LC 15)  
 Max Grav A=166(LC 2), C=166(LC 2), D=304(LC 2)

**FORCES.** (lb) - Max. Comp./Max. Ten. - All forces 250 (lb) or less except when shown.

- NOTES-**
- Unbalanced roof live loads have been considered for this design.
  - Wind: ASCE 7-10; Vult=120mph (3-second gust) Vasd=95mph; TC DL=6.0psf; BCDL=6.0psf; h=30ft; Cat. II; Exp B; Enclosed; MWFRS (envelope) gable end zone and C-C Exterior(2) zone; C-C for members and forces & MWFRS for reactions shown; Lumber DOL=1.60 plate grip DOL=1.33
  - TCLL: ASCE 7-10; Pr=20.0 psf (roof live load; Lumber DOL=1.15 Plate DOL=1.00); Pg=15.0 psf (ground snow); Pf=10.4 psf (flat roof snow; Lumber DOL=1.15 Plate DOL=1.00); Category II; Exp B; Fully Exp.; Ct=1.10
  - Unbalanced snow loads have been considered for this design.
  - Gable requires continuous bottom chord bearing.
  - This truss has been designed for a 10.0 psf bottom chord live load nonconcurrent with any other live loads.
  - \* This truss has been designed for a live load of 20.0psf on the bottom chord in all areas where a rectangle 3-6-0 tall by 2-0-0 wide will fit between the bottom chord and any other members.
  - Provide mechanical connection (by others) of truss to bearing plate capable of withstanding 100 lb uplift at joint(s) A, C.

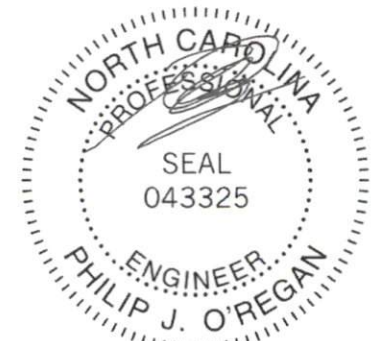

December 4, 2019

Job 19-114808T	Truss V03	Truss Type Valley	Qty 1	Ply 1	KEN DAWSON PLAN 1341	T18803248
-------------------	--------------	----------------------	----------	----------	----------------------	-----------

BMC (Middlesex, NC), Middlesex, NC - 27557, 8.240 s Jul 14 2019 MiTek Industries, Inc. Tue Dec 3 17:26:55 2019 Page 1  
 ID:9ohifRTVSugSpHSw?zcUgvyCcmY-W7ds8HaYRVIOAExFCyWU6J6z3f?GbZvgK26YzyCcD\_

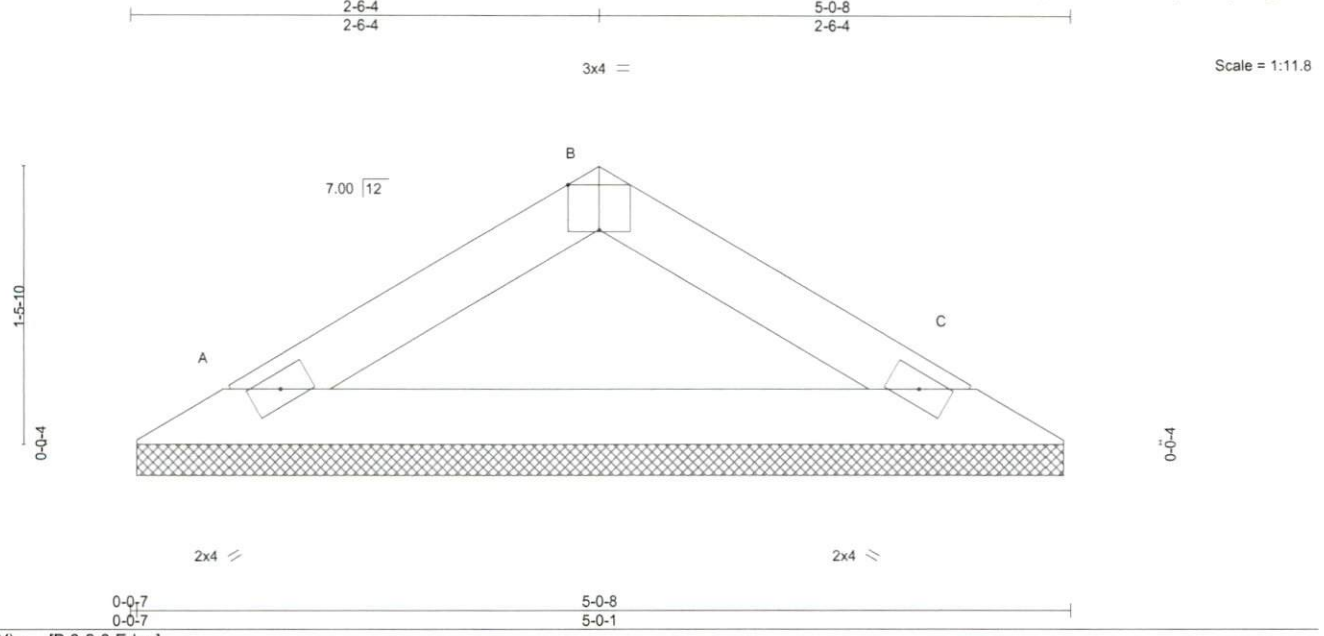

LOADING (psf)		SPACING-		CSI.		DEFL.				PLATES	GRIP	
TCLL (roof)	20.0	Plate Grip DOL	1.00	TC	0.07	Vert(LL)	n/a	-	n/a	999	MT20	244/190
Snow (Pf/Pg)	10.4/15.0	Lumber DOL	1.15	BC	0.19	Vert(CT)	n/a	-	n/a	999		
TCDL	10.0	Rep Stress Incr	YES	WB	0.00	Horz(CT)	0.00	C	n/a	n/a		
BCLL	0.0 *	Code	IRC2015/TPI2014	Matrix-P							Weight: 14 lb	FT = 20%
BCDL	10.0											

**LUMBER-**  
 TOP CHORD 2x4 SP No.2  
 BOT CHORD 2x4 SP No.2

**BRACING-**  
 TOP CHORD Structural wood sheathing directly applied or 5-0-8 oc purlins.  
 BOT CHORD Rigid ceiling directly applied or 10-0-0 oc bracing.

**REACTIONS.** (lb/size) A=120/4-11-10, C=120/4-11-10  
 Max Horz A=24(LC 11)  
 Max Uplift A=-8(LC 14), C=-8(LC 15)  
 Max Grav A=158(LC 2), C=158(LC 2)

**FORCES.** (lb) - Max. Comp./Max. Ten. - All forces 250 (lb) or less except when shown.

- NOTES-**
- Unbalanced roof live loads have been considered for this design.
  - Wind: ASCE 7-10; Vult=120mph (3-second gust) Vasd=95mph; TCDL=6.0psf; BCDL=6.0psf; h=30ft; Cat. II; Exp B; Enclosed; MWFRS (envelope) gable end zone and C-C Exterior(2) zone; C-C for members and forces & MWFRS for reactions shown; Lumber DOL=1.60 plate grip DOL=1.33
  - TCLL: ASCE 7-10; Pr=20.0 psf (roof live load; Lumber DOL=1.15 Plate DOL=1.00); Pg=15.0 psf (ground snow); Pf=10.4 psf (flat roof snow; Lumber DOL=1.15 Plate DOL=1.00); Category II; Exp B; Fully Exp.; Ct=1.10
  - Unbalanced snow loads have been considered for this design.
  - Gable requires continuous bottom chord bearing.
  - This truss has been designed for a 10.0 psf bottom chord live load nonconcurrent with any other live loads.
  - \* This truss has been designed for a live load of 20.0psf on the bottom chord in all areas where a rectangle 3-6-0 tall by 2-0-0 wide will fit between the bottom chord and any other members.
  - Provide mechanical connection (by others) of truss to bearing plate capable of withstanding 100 lb uplift at joint(s) A, C.

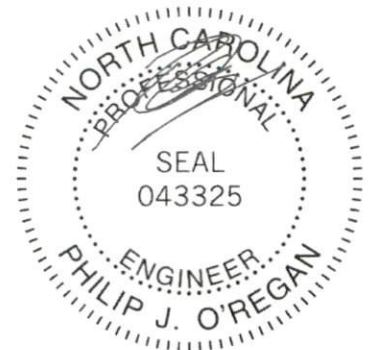

December 4, 2019



# Symbols

## PLATE LOCATION AND ORIENTATION

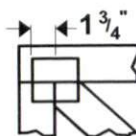

Center plate on joint unless x, y offsets are indicated. Dimensions are in ft-in-sixteenths. Apply plates to both sides of truss and fully embed teeth.

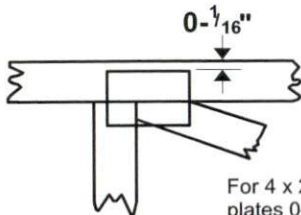

For 4 x 2 orientation, locate plates 0- $\frac{1}{16}$ " from outside edge of truss.



This symbol indicates the required direction of slots in connector plates.

\* Plate location details available in MiTek 20/20 software or upon request.

## PLATE SIZE

4 x 4

The first dimension is the plate width measured perpendicular to slots. Second dimension is the length parallel to slots.

## LATERAL BRACING LOCATION

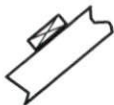

Indicated by symbol shown and/or by text in the bracing section of the output. Use T or I bracing if indicated.

## BEARING



Indicates location where bearings (supports) occur. Icons vary but reaction section indicates joint number where bearings occur. Min size shown is for crushing only.

### Industry Standards:

- ANSI/TPI1: National Design Specification for Metal Plate Connected Wood Truss Construction.  
 DSB-89: Design Standard for Bracing.  
 BCSI: Building Component Safety Information, Guide to Good Practice for Handling, Installing & Bracing of Metal Plate Connected Wood Trusses.

# Numbering System

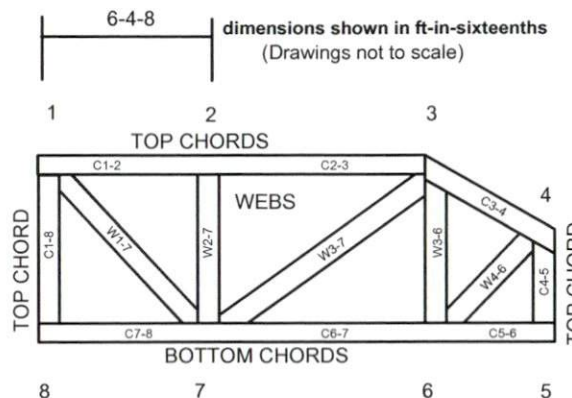

JOINTS ARE GENERALLY NUMBERED/LETTERED CLOCKWISE AROUND THE TRUSS STARTING AT THE JOINT FARTHEST TO THE LEFT.

CHORDS AND WEBS ARE IDENTIFIED BY END JOINT NUMBERS/LETTERS.

## PRODUCT CODE APPROVALS

ICC-ES Reports:

ESR-1311, ESR-1352, ESR1988  
 ER-3907, ESR-2362, ESR-1397, ESR-3282

Trusses are designed for wind loads in the plane of the truss unless otherwise shown.

Lumber design values are in accordance with ANSI/TPI 1 section 6.3 These truss designs rely on lumber values established by others.

© 2012 MiTek® All Rights Reserved



MiTek Engineering Reference Sheet: MII-7473 rev. 10/03/2015

# General Safety Notes

## Failure to Follow Could Cause Property Damage or Personal Injury

1. Additional stability bracing for truss system, e.g. diagonal or X-bracing, is always required. See BCSI.
2. Truss bracing must be designed by an engineer. For wide truss spacing, individual lateral braces themselves may require bracing, or alternative Tor I bracing should be considered.
3. Never exceed the design loading shown and never stack materials on inadequately braced trusses.
4. Provide copies of this truss design to the building designer, erection supervisor, property owner and all other interested parties.
5. Cut members to bear tightly against each other.
6. Place plates on each face of truss at each joint and embed fully. Knots and wane at joint locations are regulated by ANSI/TPI 1.
7. Design assumes trusses will be suitably protected from the environment in accord with ANSI/TPI 1.
8. Unless otherwise noted, moisture content of lumber shall not exceed 19% at time of fabrication.
9. Unless expressly noted, this design is not applicable for use with fire retardant, preservative treated, or green lumber.
10. Camber is a non-structural consideration and is the responsibility of truss fabricator. General practice is to camber for dead load deflection.
11. Plate type, size, orientation and location dimensions indicated are minimum plating requirements.
12. Lumber used shall be of the species and size, and in all respects, equal to or better than that specified.
13. Top chords must be sheathed or purlins provided at spacing indicated on design.
14. Bottom chords require lateral bracing at 10 ft. spacing, or less, if no ceiling is installed, unless otherwise noted.
15. Connections not shown are the responsibility of others.
16. Do not cut or alter truss member or plate without prior approval of an engineer.
17. Install and load vertically unless indicated otherwise.
18. Use of green or treated lumber may pose unacceptable environmental, health or performance risks. Consult with project engineer before use.
19. Review all portions of this design (front, back, words and pictures) before use. Reviewing pictures alone is not sufficient.
20. Design assumes manufacture in accordance with ANSI/TPI 1 Quality Criteria.



8401 PLANER MILL ROAD  
MIDDLESEX, NC 27557  
PH: (252)235-4530

Valued Customer  
PH-(654) 321-7890 FAX-  
SOUTH CO.  
NORTH CO.

# ORDER ESTIMATE

ORDER # **19-114808T**  
PAGE 1  
DATE 12/03/19  
DESIGNER: LISA SCHICHEL

JOB NAME: KEN DAWSON HOMES  
MODEL: PLAN 1341 GARAGE LEFT

TAG: ROOF TRUSSES  
LOT #: SUBDIV:

**DELIVERY INSTRUCTIONS:**  
ELEVATION DRAWING NEEDED PRIOR TO  
MANUFACTURE OF ANY TRUSSES

## ROOF TRUSSES

### LOADING INFORMATION

TCLL-TCDL-BCLL-BCDL	STRESS INCR.
20.0,10.0,0.0,10.0	1.15

ROOF TRUSS SPACING: 24.0 IN. O.C. (TYP.)

PROFILE	QTY PLY	PITCH		TYPE ID	BASE SPAN	O/A SPAN	LUMBER		HEEL HEIGHT		OVERHANG		CANTILEVER	
		TOP	BOT				TOP	BOT	LEFT	RIGHT	LEFT	RIGHT	LEFT	RIGHT
	1	7.00	0.00	COMMON A01	20-08-00	20-08-00	2 X 4	2 X 4	00-04-05	00-04-05	00-10-08	00-10-08		
	4	7.00	0.00	COMMON A02	20-08-00	20-08-00	2x4	2x4	00-04-05	00-04-05	00-10-08	00-10-08		
	1	7.00	0.00	COMMON A03	26-09-00	26-09-00	2 X 4	2 X 4	00-04-05	00-04-05	00-10-08	00-10-08		
	7	7.00	0.00	COMMON A04	20-08-00	20-08-00	2x4	2x4	00-04-05	03-10-14	00-10-08			
	1	7.00	0.00	COMMON A05	20-11-00	20-11-00	2 X 4	2 X 4	00-04-05	08-08-10	00-10-08			
	5	7.00	0.00	COMMON A06	20-11-00	20-11-00	2x4	2x4	00-04-05	08-08-10	00-10-08			04-06-08
	5	7.00	0.00	COMMON A07	20-11-00	20-11-00	2x4	2x4	00-04-05	08-08-10	00-10-08			
	3	7.00	0.00	COMMON A08	35-09-08	35-09-08	2x4	2x4	00-04-05	00-00-08	00-10-08			
	5	7.00	0.00	COMMON A09	35-03-00	35-03-00	2x4	2x4	00-04-05	00-04-05		00-10-08		00-04-00
	2	7.00	0.00	COMMON A10	35-03-00	35-03-00	2x4	2x4	00-04-05	00-04-05	00-10-08	00-10-08		
	4	7.00	0.00	COMMON A11	35-03-00	35-03-00	2x4	2x4	00-04-05	00-04-05		00-10-08		
	1	7.00	0.00	COMMON A12	35-03-00	35-03-00	2 X 4	2 X 4	00-04-05	00-04-05		00-10-08		
	1	7.00	0.00	VALLEY V01	13-00-08	13-00-08	2 X 4	2 X 4	00-00-00	00-00-00				
	1	7.00	0.00	VALLEY V02	08-11-10	08-11-10	2 X 4	2 X 4	00-00-04	00-00-04				
	1	7.00	0.00	VALLEY V03	04-11-10	04-11-10	2 X 4	2 X 4	00-00-04	00-00-04				

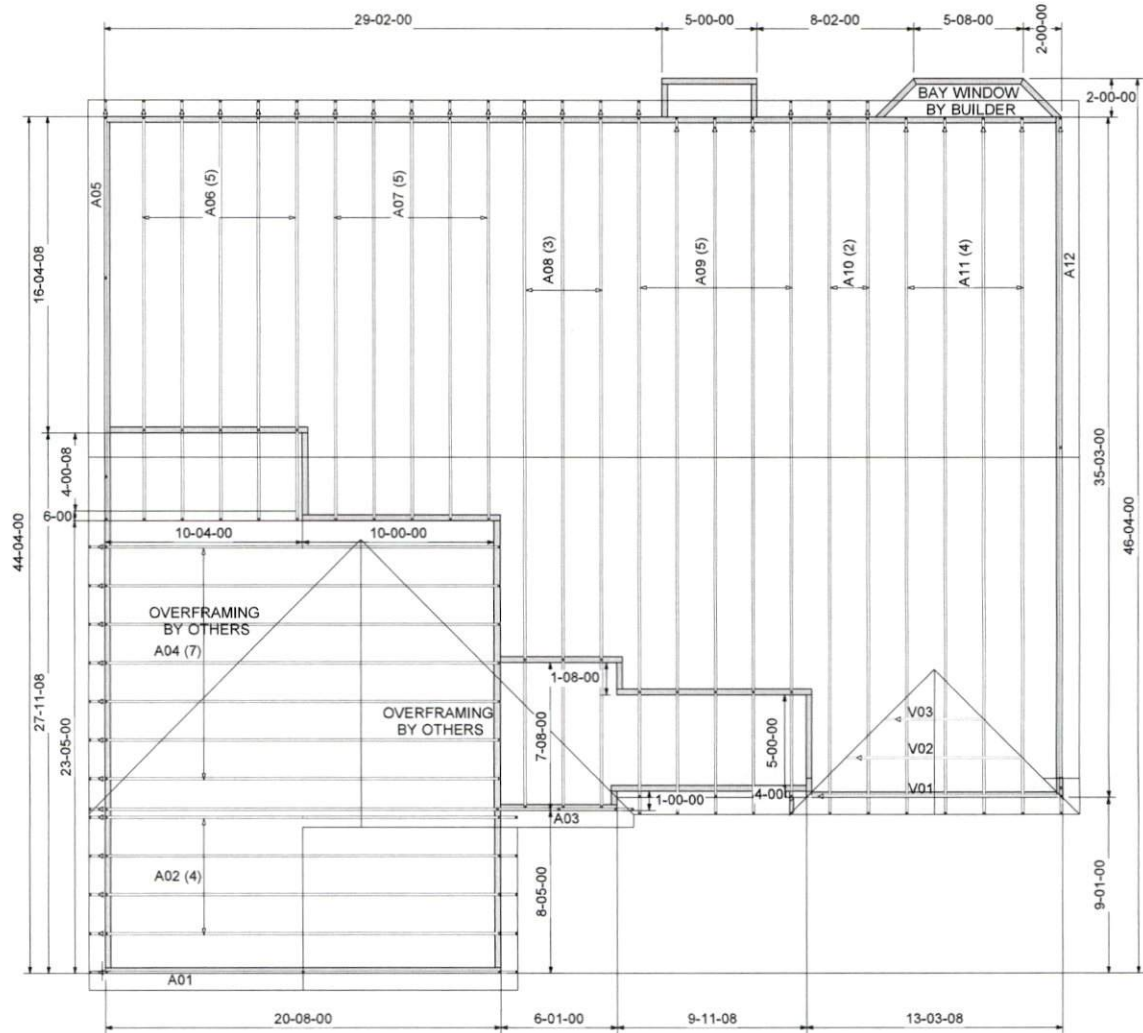

**NOTES:**

- 1) TRUSS SPACING 24" o/c UNLESS NOTED OTHERWISE.
- 2) SEE ENGINEERED TRUSS DRAWINGS FOR NOTES AND REQUIRED BRACING OF TRUSS WEBS IN ADDITION TO BCSI-B1 SUMMARY SHEET FOR HANDLING, INSTALLING AND BRACING.
- 3) FOLLOW SIMPSONS INSTALLATION RECOMMENDATIONS FOR HANGER CONNECTIONS.
- 4) VERIFY ALL BUILDING DIMENSIONS PRIOR TO TRUSS ERECTION.
- 5) EXTERIOR DIMENSIONS ARE FROM OUT TO OUT OF SHEATHING UNLESS NOTED OTHERWISE.
- 6) DO NOT CUT, DRILL OR ALTER TRUSS WITH OUT CONSULTING A REGISTERED PROFESSIONAL ENGINEER.
- 7) ATTIC ACCESS MUST BE PLACED BETWEEN TRUSSES.
- 8) BUILDER IS RESPONSIBLE FOR PROVIDING ADEQUATE BEARING TO SUPPORT TRUSS REACTIONS.
- 9) DIMENSIONS ARE IN FEET-INCHES-SIXTEENTHS.
- 10) NO HANGERS ARE REQUIRED FOR SMALL, OPEN-ENDED TRUSSES. INSTEAD, USE 3 NAILS IN BOTH THE TOP AND BOTTOM CHORDS.



Customer: <b>KEN DAWSON</b>	
Job Name: <b>ONE STORY RESIDENCE</b>	Plan/Model: <b>1341 GARAGE LEFT</b>
Level: <b>ROOF - LH</b>	Drawn By: <b>LJS</b> Job #: <b>19-114808T</b>
Scale: N.T.S.	Date: 12/03/2019
STOCK COMPONENTS, NC & SC 1-800-672-2145	

THIS IS A TRUSS PLACEMENT DIAGRAM ONLY. These trusses are designed as individual building components to be incorporated into the building design at the specification of the building designer. It is the builder's responsibility to verify that the structure can support the entire roof or floor truss system. See engineered drawings for required lateral bracing and other information for each truss design identified on this placement drawing. The building designer is responsible for permanent bracing of the roof and floor system and for the overall structure. For general guidance regarding bracing, consult the BCSI-B1 SUMMARY SHEET, provided by BMC. THE BUILDER IS CAUTIONED to seek professional advice or follow the bracing guidelines of BCSI-B1 while installing the trusses in order to prevent toppling or diminishing of inadequately braced trusses.