



**Boise Cascade**  
www.bldr.com

1135 ROBESON STREET  
FAYETTEVILLE, NC 28305  
V (910) 485-1111

7601 BOEING DRIVE  
GREENSBORO, NC 27409  
V (336) 884-5454

3189 NC HIGHWAY 5  
ABERDEEN NC 28315  
V (910) 944-2516

This layout and associated materials list has been prepared based on project plans and/or information provided to Builders FirstSource (BFS). It remains the responsibility of the builder, architect, designer, or other responsible persons to review this information to assure that it is appropriate, accurate, complete and complies with applicable building codes.

- GENERAL NOTES:**
- 1.) READ THE INSTALLATION GUIDE BEFORE FRAMING.
  - 2.) ALL WALLS SHOWN ARE LOAD BEARING UNLESS NOTED OTHERWISE. WALLS NOT SHOWN ARE CONSIDERED NON-LOAD BEARING.
  - 3.) UNLESS STATED OTHERWISE ALL CEILING & ROOF LOADS BRACE DIRECTLY TO LOAD BEARING WALLS SUPPORTED BY FOUNDATION.
  - 4.) CONTACT BUILDERS FIRSTSOURCE BEFORE MAKING ANY ALTERATIONS OR ADJUSTMENTS...FAILURE TO DO SO MAY RESULT IN COSTLY REPAIRS.

**H&H HOMES**  
**FREELANCE R**

2ND FLOOR PLACEMENT PLAN

Builders FirstSource, Central Carolina Markets

DATE: 11/06/2019  
DRAWN BY: AJ Napier  
JOB NUMBER:  
SCALE: NTS

MINIMUM DESIGN DATA

LIVE LOAD 40 PSF  
DEAD LOAD 10 PSF

TOTAL LOAD 50 PSF

DOL = 100%

DEFLECTION CRITERIA  
L/480 (MINIMUM)

ARCHITECTURAL PLAN DATE

11-16-2017

REVISED ARCH. PLAN DATE

XX-XX-XX

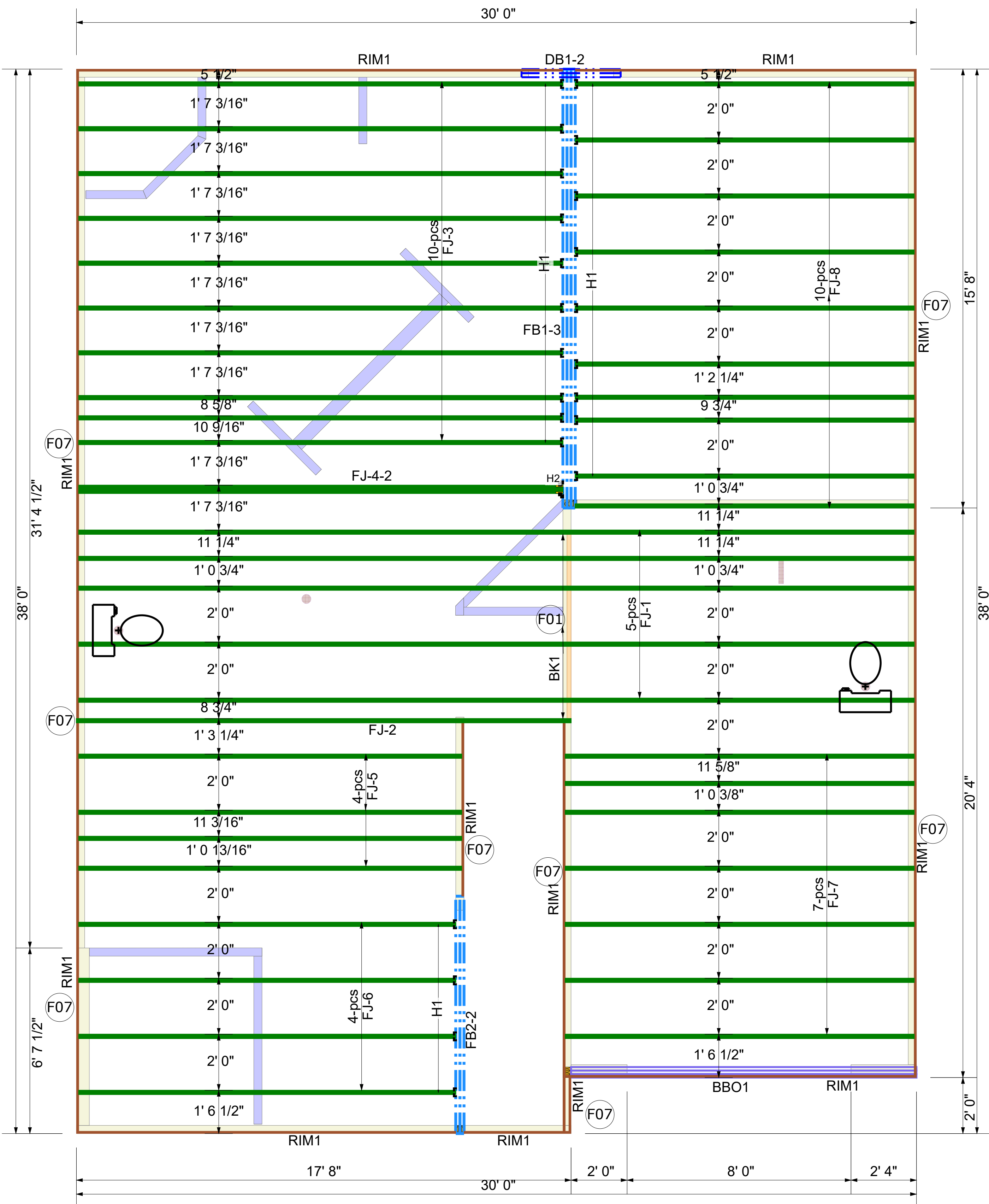
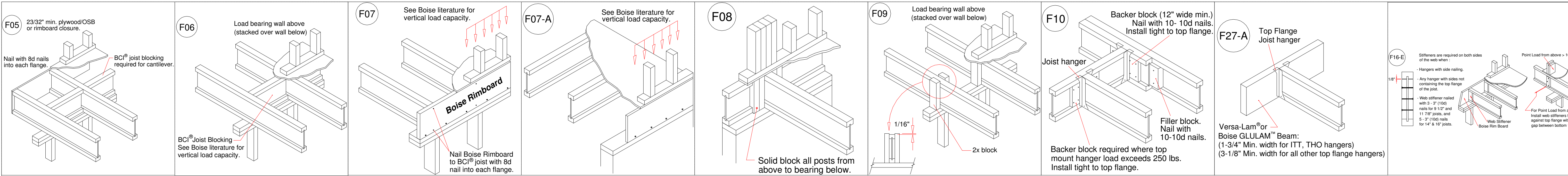

Products				
PlotID	Length	Product	Plies	Net Qty
FJ-1	29' 10"	14" BCI® 4500s-1.8	1	5
FJ-2	17' 8"	14" BCI® 4500s-1.8	1	1
FJ-3	17' 3 1/2"	14" BCI® 4500s-1.8	1	10
FJ-4-2	17' 3 1/2"	14" BCI® 4500s-1.8	2	2
FJ-5	13' 8 1/4"	14" BCI® 4500s-1.8	1	4
FJ-6	13' 5 3/4"	14" BCI® 4500s-1.8	1	4
FJ-7	12' 5 1/2"	14" BCI® 4500s-1.8	1	7
FJ-8	12' 1 1/4"	14" BCI® 4500s-1.8	1	10
DB1-2	4' 0"	1-3/4" x 9-1/4" VERSA-LAM® 2.0 3100 SP	2	2
FB1-3	16' 0"	1-3/4" x 14" VERSA-LAM® 2.0 3100 SP	3	3
FB2-2	10' 0"	1-3/4" x 14" VERSA-LAM® 2.0 3100 SP	2	2
RIM1	12' 0"	1" x 14" BC RIM BOARD OSB	1	13
BK1	2' 0"	14" BCI® 4500s-1.8	1	4

Hangers			
PlotID	Qty	Manuf	Product
H1	23	Simpson	IUS 1.81/14
H2	1	Simpson	IUS 3.56/14
FB1-3 Structural Screws*	50	Simpson	SDW22500*

**FREELANCE**