

COMMENTS: _____

LANDSCAPE POSITIONS	GROUP	TEXTURES	.1955 LTAR	CONSISTENCE MOIST	WET
R-RIDGE	I	S-SAND	1.2 - 0.8	VFR-VERY FRIABLE FR-FRIABLE	NS-NON-STICKY SS-SLIGHTLY STICKY
S-SHOULDER SLOPE		LS-LOAMY SAND			
L-LINEAR SLOPE	II	SL-SANDY LOAM	0.8 - 0.6	FI-FIRM VFI-VERY FIRM	S-STICKY VS-VERY STICKY
FS-FOOT SLOPE		L-LOAM			
N-NOSE SLOPE	III	SI-SILT	0.6 - 0.3	EFI-EXTREMELY FIRM	NP-NON-PLASTIC SP-SLIGHTLY STICKY P-PLASTIC VP-VERY PLASTIC
H-HEAD SLOPE		SIL-SILT LOAM			
CC-CONCLAVE SLOPE		CL-CLAY LOAM			
CV-CONVEX SLOPE		SCL-SANDY CLAY LOAM			
T-TERRACE	IV	SIC-SILTY CLAY	0.4 - 0.1		
FP-FLOOD PLAN		C-CLAY SC-SANDY CLAY			

STRUCTURE
 SG-SINGLE GRAIN
 M- MASSIVE
 CR-CRUMB
 GR-GRANULAR
 SBK-SUBANGULAR BLOCKY
 ABK-ANGULAR BLOCKY
 PL-PLATY
 PR-PRISMATIC

MINERALOGY
 SLIGHTLY EXPANSIVE
 EXPANSIVE

Show profile locations and other site features (dimensions, references or benchmark, and North)

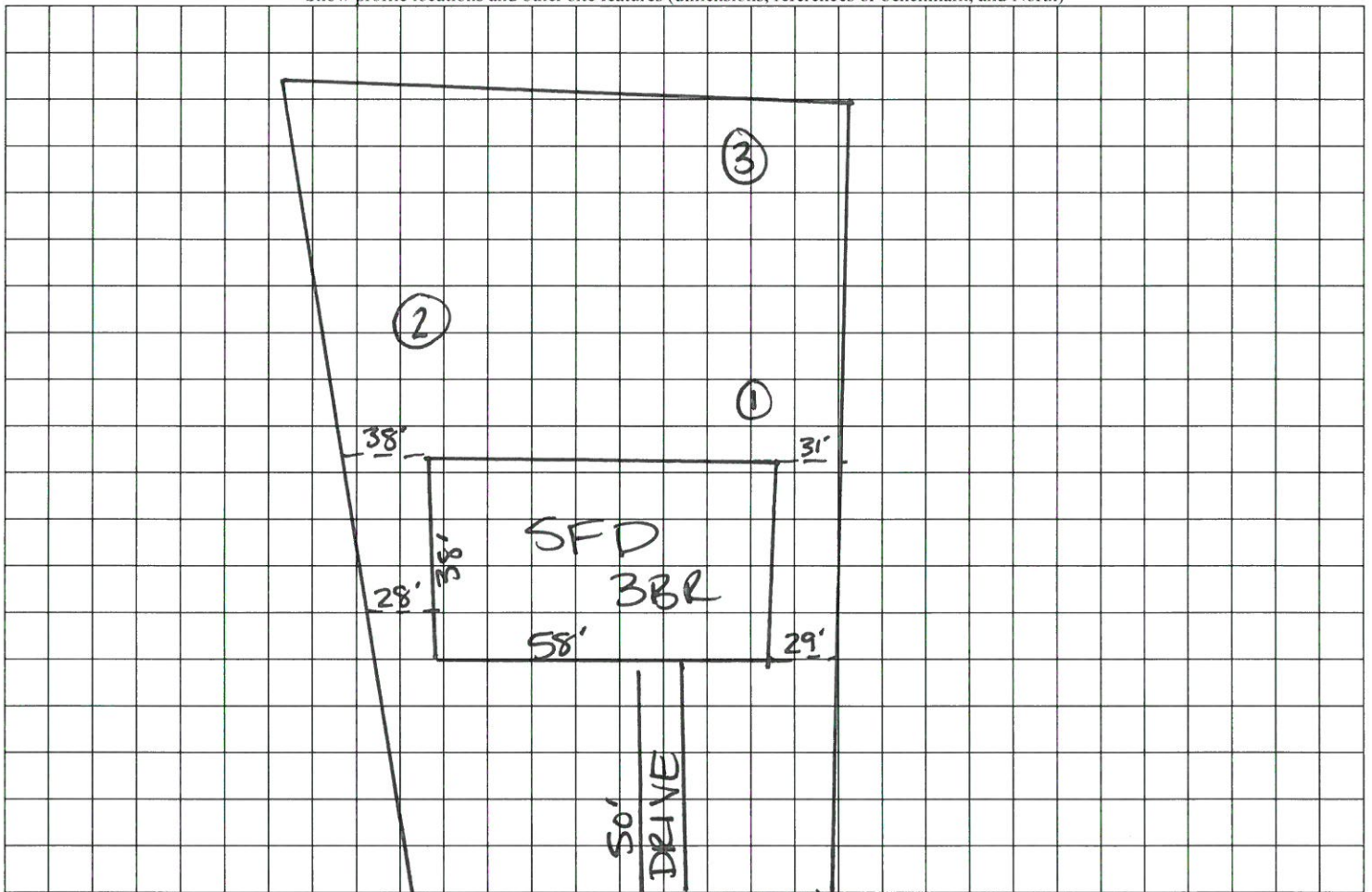

Ponderosa Tr 1