



Boise Cascade
www.bldr.com

1135 ROBESON STREET
FAYETTEVILLE, NC 28305
V (910) 485-1111

7601 BOEING DRIVE
GREENSBORO, NC 27409
V (336) 884-5454

3189 NC HIGHWAY 5
ABERDEEN NC 28315
V (910) 944-2516

This layout and associated materials list has been prepared based on project plans and/or information provided to Builders FirstSource (BFS). It remains the responsibility of the builder, architect, designer, or other responsible persons to review this information to assure that it is appropriate, accurate, complete and complies with applicable building codes.

- GENERAL NOTES:**
- 1.) READ THE INSTALLATION GUIDE BEFORE FRAMING.
 - 2.) ALL WALLS SHOWN ARE LOAD BEARING UNLESS NOTED OTHERWISE. WALLS NOT SHOWN ARE CONSIDERED NON-LOAD BEARING.
 - 3.) UNLESS STATED OTHERWISE ALL CEILING & ROOF LOADS BRACE DIRECTLY TO LOAD BEARING WALLS SUPPORTED BY FOUNDATION.
 - 4.) CONTACT BUILDERS FIRSTSOURCE BEFORE MAKING ANY ALTERATIONS OR ADJUSTMENTS...FAILURE TO DO SO MAY RESULT IN COSTLY REPAIRS.

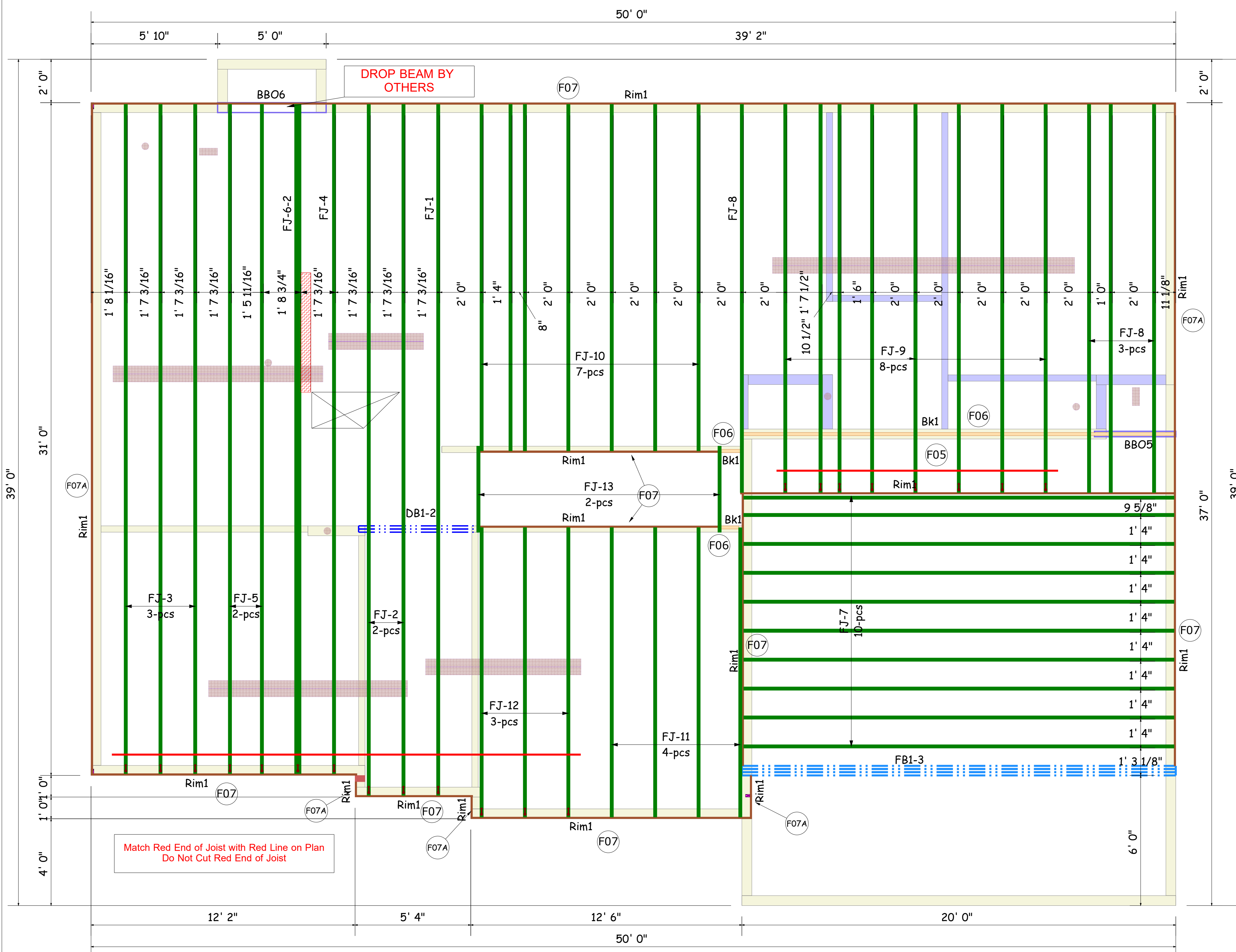
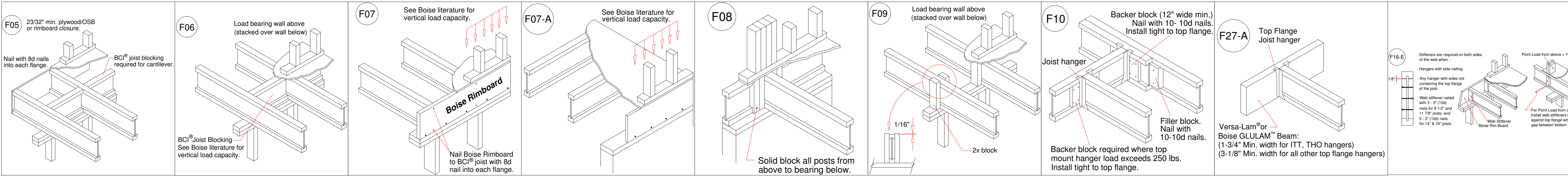

| PlotID | Length | Product | Plies | Net Qty |
|--------|-------------|--|-------|---------|
| FJ-1 | 31' 10" | 14" BCI@ 4500s-1.8 | 1 | 1 |
| FJ-2 | 31' 10" | 14" BCI@ 4500s-1.8 | 1 | 2 |
| FJ-3 | 30' 10" | 14" BCI@ 4500s-1.8 | 1 | 3 |
| FJ-4 | 30' 10" | 14" BCI@ 4500s-1.8 | 1 | 1 |
| FJ-5 | 30' 10" | 14" BCI@ 4500s-1.8 | 1 | 2 |
| FJ-6-2 | 30' 10" | 14" BCI@ 4500s-1.8 | 2 | 2 |
| FJ-7 | 19' 10" | 14" BCI@ 4500s-1.8 | 1 | 10 |
| FJ-8 | 17' 10 1/2" | 14" BCI@ 4500s-1.8 | 1 | 4 |
| FJ-9 | 17' 10 1/2" | 14" BCI@ 4500s-1.8 | 1 | 8 |
| FJ-10 | 15' 11 1/2" | 14" BCI@ 4500s-1.8 | 1 | 7 |
| FJ-11 | 13' 4" | 14" BCI@ 4500s-1.8 | 1 | 4 |
| FJ-12 | 13' 4" | 14" BCI@ 4500s-1.8 | 1 | 3 |
| FJ-13 | 3' 11 1/2" | 14" BCI@ 4500s-1.8 | 1 | 2 |
| DB1-2 | 6' 0" | 1-3/4" x 9-1/4" VERSA-LAM® 2.0 3100 SP | 2 | 2 |
| FB1-3 | 20' 0" | 1-3/4" x 24" VERSA-LAM® 2.0 3100 SP | 3 | 3 |
| Rim1 | 12' 0" | 1" x 14" BC RIM BOARD OSB | 1 | 17 |
| BK1 | 20' 0" | 14" BCI@ 4500s-1.8 | 1 | 1 |

WILMINGTON
SEAL DATE 4-4-18
2nd FLOOR EWP PLACEMENT PLAN

H&H Homes
Wilmington R
2ND FLOOR EWP PLACEMENT PLAN
Builders FirstSource, Central Carolina Markets
DRAWN BY: AJ Napier
DATE: 4/28/2019
JOB NUMBER:
SCALE: NTS

MINIMUM DESIGN DATA
LIVE LOAD 40 PSF
DEAD LOAD 10 PSF
TOTAL LOAD 50 PSF
DOL = 100%
DEFLECTION CRITERIA L/480 (MINIMUM)
ARCHITECTURAL PLAN DATE XX-XX-XX
REVISED ARCH. PLAN DATE XX-XX-XX
Sheet 1 of 1