

Trenco

818 Soundside Rd
Edenton, NC 27932

Re: 1703072R

The truss drawing(s) referenced below have been prepared by Truss Engineering Co. under my direct supervision based on the parameters provided by Builders FirstSource (Albermarle,NC).

Pages or sheets covered by this seal: E13353937 thru E13353937

My license renewal date for the state of North Carolina is December 31, 2019.

North Carolina COA: C-0844



August 2, 2019

Gilbert, Eric

IMPORTANT NOTE: The seal on these truss component designs is a certification that the engineer named is licensed in the jurisdiction(s) identified and that the designs comply with ANSI/TPI 1. These designs are based upon parameters shown (e.g., loads, supports, dimensions, shapes and design codes), which were given to MiTek or TRENCO. Any project specific information included is for MiTek's or TRENCO's customers file reference purpose only, and was not taken into account in the preparation of these designs. MiTek or TRENCO has not independently verified the applicability of the design parameters or the designs for any particular building. Before use, the building designer should verify applicability of design parameters and properly incorporate these designs into the overall building design per ANSI/TPI 1, Chapter 2.

1703072R	Truss R2	Truss Type Common	Qty 3	Ply 1	Job Reference (optional)	E13353937
----------	-------------	----------------------	----------	----------	--------------------------	-----------

Builders FirstSource, Albemarle, NC 28001 8,220 s Nov 18 2018 MiTek Industries, Inc. Fri Aug 2 09:59:15 2019 Page 1
 ID:ZyLTBUxGwKX7joNWX3n_GAzWwNI-kNmDkKws_MboY6qOvE5taYRO9r7EETSyDUQ6ysyrwMw

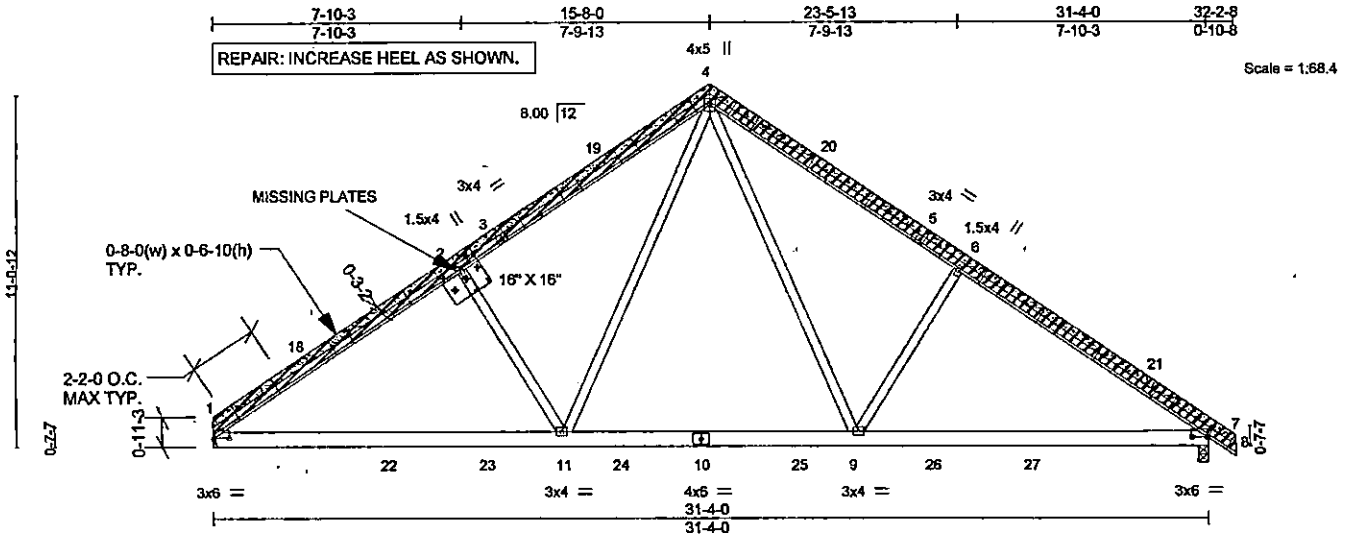

- INSTALL 2x4 SP NO.2 RIPPED AS SHOWN CUT TO FIT TIGHT.
- APPLY 2x6 SP NO.2 SCAB TO ONE FACE AS SHOWN. ATTACH WITH CONSTRUCTION QUALITY ADHESIVE AND (0.131" X 3") NAILS PER THE FOLLOWING NAIL SCHEDULE: ORIGINAL 2x4 TOP CHORDS - 1 ROW, RIPPED 2x4'S - 2 ROWS: SPACED @ 4" O.C. USE 2" MEMBER END DISTANCE.
- ATTACH 1/2" PLYWOOD OR OSB GUSSET (15/32" RATED SHEATHING 32/16 EXP 1) TO ONE FACE OF TRUSS WITH CONSTRUCTION QUALITY ADHESIVE AND (3) (0.113" X 2") NAILS INTO EACH CHORD AS SHOWN (TOTAL - 6 NAILS PER GUSSET).

Plate Offsets (X,Y) =	[1:0-6-0,0-0-2], [7:0-6-0,0-0-2]							
LOADING (psf)	SPACING- 2-0-0	CSI.	DEFL.	in (loc)	I/def	L/d	PLATES	GRIP
TCLL (roof) 20.0	Plate Grip DOL 1.15	TC 0.62	Vert(LL)	-0.11 9-17	>999	360	MT20	244/190
Snow (Pf/Pg) 15.4/20.0	Lumber DOL 1.15	BC 0.56	Vert(CT)	-0.23 11-14	>999	240		
TCDL 10.0	Rep Stress incr YES	WB 0.33	Horz(CT)	0.03 7	n/a	n/a		
BCLL 0.0	Code IRC2015/TP12014	Matrix-AS	Wind(LL)	0.04 11-14	>999	240		
BCDL 10.0							Weight: 183 lb	FT = 20%

LUMBER-
 TOP CHORD 2x4 SP No.2
 BOT CHORD 2x6 SP No.2
 WEBS 2x4 SP No.3

BRACING-
 TOP CHORD Structural wood sheathing directly applied.
 BOT CHORD Rigid ceiling directly applied.

REACTIONS. (lb/size) 1=1109/Mechanical, 7=1154/0-3-8
 Max Horz 1=168(LC 12)
 Max Grav 1=1318(LC 26), 7=1366(LC 27)

FORCES. (lb) - Max. Comp./Max. Ten. - All forces 250 (lb) or less except when shown.
 TOP CHORD 1-2=-1879/81, 2-4=-1690/140, 4-6=-1687/136, 6-7=-1877/77
 BOT CHORD 1-11=0/1596, 9-11=0/1057, 7-9=0/1476
 WEBS 4-9=-12/798, 6-9=-430/154, 4-11=-14/801, 2-11=-431/154

- NOTES-**
- Unbalanced roof live loads have been considered for this design.
 - Wind: ASCE 7-10; Vult=115mph (3-second gust) Vasd=91mph; TC DL=6.0psf; BC DL=6.0psf; h=25ft; Cat. II; Exp B; Enclosed; MWFRS (envelope) and C-C Exterior(2) 0-0-0 to 3-1-10, Interior(1) 3-1-10 to 15-8-0, Exterior(2) 15-8-0 to 18-9-10, Interior(1) 18-9-10 to 32-2-8 zone; cantilever left and right exposed ;C-C for members and forces & MWFRS for reactions shown; Lumber DOL=1.60 plate grip DOL=1.60
 - TCLL: ASCE 7-10; Pf=20.0 psf (roof live load; Lumber DOL=1.15 Plate DOL=1.15); Pg=20.0 psf (ground snow); Pf=15.4 psf (flat roof snow; Lumber DOL=1.15 Plate DOL=1.15); Category II; Exp B; Partially Exp.; Ct=1.10
 - This truss has been designed for greater of min roof live load of 12.0 psf or 1.00 times flat roof load of 15.4 psf on overhangs non-concurrent with other live loads.
 - This truss has been designed for a 10.0 psf bottom chord live load nonconcurrent with any other live loads.
 - * This truss has been designed for a live load of 20.0psf on the bottom chord in all areas where a rectangle 3-6-0 tall by 2-0-0 wide will fit between the bottom chord and any other members, with BCDL = 10.0psf.
 - Refer to girder(s) for truss to truss connections.
 - This truss design requires that a minimum of 7/16" structural wood sheathing be applied directly to the top chord and 1/2" gypsum sheetrock be applied directly to the bottom chord.

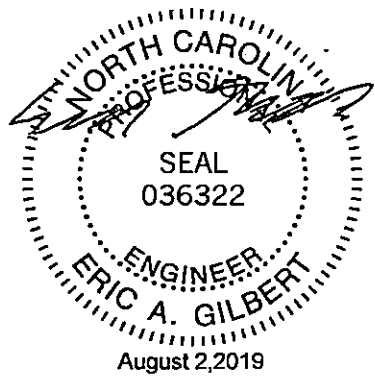

Symbols

PLATE LOCATION AND ORIENTATION

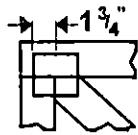

Center plate on joint unless x, y offsets are indicated. Dimensions are in ft-in-sixteenths. Apply plates to both sides of truss and fully embed teeth.

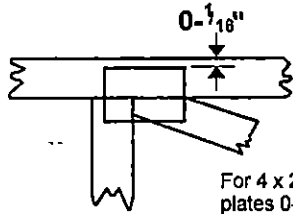

For 4 x 2 orientation, locate plates 0- 1/16" from outside edge of truss.



This symbol indicates the required direction of slots in connector plates.

* Plate location details available in MITek 20/20 software or upon request.

PLATE SIZE

4 x 4

The first dimension is the plate width measured perpendicular to slots. Second dimension is the length parallel to slots.

LATERAL BRACING LOCATION

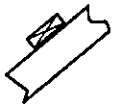

Indicated by symbol shown and/or by text in the bracing section of the output. Use T or I bracing if indicated.

BEARING

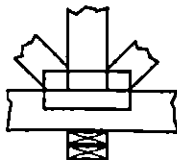

Indicates location where bearings (supports) occur. Icons vary but reaction section indicates joint number where bearings occur. Min size shown is for crushing only.

Industry Standards:

- ANSI/TPI1: National Design Specification for Metal Plate Connected Wood Truss Construction.
- DSB-89: Design Standard for Bracing.
- BCSI: Building Component Safety Information, Guide to Good Practice for Handling, Installing & Bracing of Metal Plate Connected Wood Trusses.

Numbering System

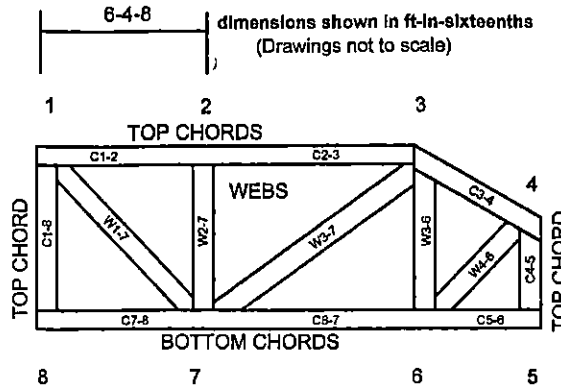

JOINTS ARE GENERALLY NUMBERED/LETTERED CLOCKWISE AROUND THE TRUSS STARTING AT THE JOINT FARTHEST TO THE LEFT.

CHORDS AND WEBS ARE IDENTIFIED BY END JOINT NUMBERS/LETTERS.

PRODUCT CODE APPROVALS

ICC-ES Reports:

ESR-1311, ESR-1352, ESR1988
ER-3907, ESR-2362, ESR-1397, ESR-3282

Trusses are designed for wind loads in the plane of the truss unless otherwise shown.

Lumber design values are in accordance with ANSI/TPI 1 section 6.3 These truss designs rely on lumber values established by others.

© 2012 MITek® All Rights Reserved



Mitek Engineering Reference Sheet: MII-7473 rev. 10/03/2015



General Safety Notes

Failure to Follow Could Cause Property Damage or Personal Injury

1. Additional stability bracing for truss system, e.g. diagonal or X-bracing, is always required. See BCSI.
2. Truss bracing must be designed by an engineer. For wide truss spacing, individual lateral braces themselves may require bracing, or alternative Top I bracing should be considered.
3. Never exceed the design loading shown and never stack materials on inadequately braced trusses.
4. Provide copies of this truss design to the building designer, erection supervisor, property owner and all other interested parties.
5. Cut members to bear tightly against each other.
6. Place plates on each face of truss at each joint and embed fully. Knots and wane at joint locations are regulated by ANSI/TPI 1.
7. Design assumes trusses will be suitably protected from the environment in accord with ANSI/TPI 1.
8. Unless otherwise noted, moisture content of lumber shall not exceed 19% at time of fabrication.
9. Unless expressly noted, this design is not applicable for use with fire retardant, preservative treated, or green lumber.
10. Camber is a non-structural consideration and is the responsibility of truss fabricator. General practice is to camber for dead load deflection.
11. Plate type, size, orientation and location dimensions indicated are minimum plating requirements.
12. Lumber used shall be of the species and size, and in all respects, equal to or better than that specified.
13. Top chords must be sheathed or purlins provided at spacing indicated on design.
14. Bottom chords require lateral bracing at 10 ft. spacing, or less, if no ceiling is installed, unless otherwise noted.
15. Connections not shown are the responsibility of others.
16. Do not cut or alter truss member or plate without prior approval of an engineer.
17. Install and load vertically unless indicated otherwise.
18. Use of green or treated lumber may pose unacceptable environmental, health or performance risks. Consult with project engineer before use.
19. Review all portions of this design (front, back, words and pictures) before use. Reviewing pictures alone is not sufficient.
20. Design assumes manufacture in accordance with ANSI/TPI 1 Quality Criteria.

Harnett County

Inspections
108 East Front Street
Lillington, NC 27546

Phone: 910-893-7525
Fax: 910-893-2793

Inspection Report

Permit: SFD1903-0008

OWNER: KMB BUILDING LLC

Site Address: 1480 OLD US 421 LILLINGTON, NC 27546

Harnett County Inspections Department

Inspection Type: ROUGH IN

Inspection Date: 08/02/2019

Result: DISAPPROVED

Remarks: eTRAKIT Inspection Request

Notes: ~~1- King studs missing at double windows.~~ ~~2- missing nail plates.~~ ~~3- missing sheet rock nailers at tub showers.~~ ~~4- standpipe should show 36 inches.~~ ~~5- Engineers letter required for repairs to roof truss three r2's.~~ ~~6- Uncompacted fill in front porch.~~ ~~7- Windows flashed incorrectly.~~ ~~8- Repair house wrap.~~ ~~9- Seal around porch PVC vent pipes to crawlspace.~~

ECON 8/1/2019 12:17:32 PM
8/1/2019 12:17 PM BROWN KEITH MICHAEL

Contact Name: BROWN KEITH MICHAEL
Site Address: 1480 OLD US 421
Phone: 9196697140
e-Mail: kmbc11@gmail.com

All violations are subject to reinspection fees at the inspectors discretion.

Scott Guy
Inspector

Trenco
818 Soundside Rd
Edenton, NC 27932

Re: 1703072R

The truss drawing(s) referenced below have been prepared by Truss Engineering Co. under my direct supervision based on the parameters provided by Builders FirstSource (Albermarle,NC).

Pages or sheets covered by this seal: E13335759 thru E13335759

My license renewal date for the state of North Carolina is December 31, 2019.

North Carolina COA: C-0844

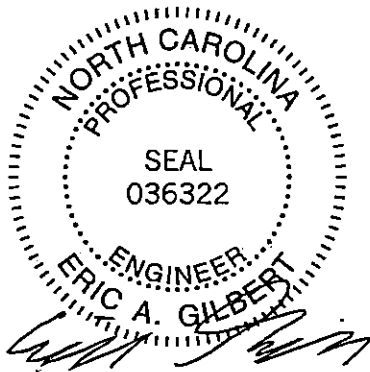

July 30,2019

Gilbert, Eric

IMPORTANT NOTE: The seal on these truss component designs is a certification that the engineer named is licensed in the jurisdiction(s) identified and that the designs comply with ANSI/TPI 1. These designs are based upon parameters shown (e.g., loads, supports, dimensions, shapes and design codes), which were given to MiTek or TRENCO. Any project specific information included is for MiTek's or TRENCO's customers file reference purpose only, and was not taken into account in the preparation of these designs. MiTek or TRENCO has not independently verified the applicability of the design parameters or the designs for any particular building. Before use, the building designer should verify applicability of design parameters and properly incorporate these designs into the overall building design per ANSI/TPI 1, Chapter 2.

173072R	Truss	Truss Type	Qty	Ply	Units: 1	E13335759
Builders FirstSource, Albemarle, NC 28001	R2	Common	3	1	Eng: GDL	

8.220 s Nov 16 2018 MiTek Industries, Inc. Tue Jul 30 07:14:35 2019 Page 1
 ID:ZyLTbuXGwKX7joNWx3n_GAzWNI-pvtYVQIWMGihFNtdcy0zXC2V2K0ukN1Zj8ysy3l
 23-5-13 31-4-0 32-2-8 0-10-8

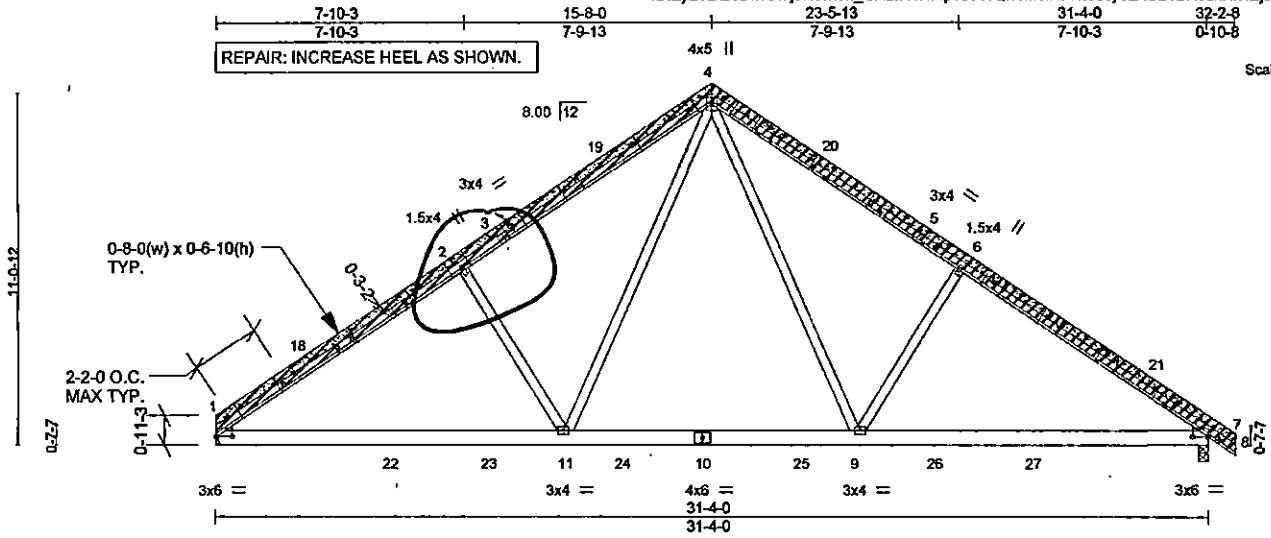

Scale = 1:68.4

INSTALL 2x4 SP NO.2 RIPPED AS SHOWN CUT TO FIT TIGHT.

APPLY 2x6 SP NO.2 SCAB TO ONE FACE AS SHOWN: ATTACH WITH CONSTRUCTION QUALITY ADHESIVE AND (0.131" X 3") NAILS PER THE FOLLOWING NAIL SCHEDULE: ORIGINAL 2x4 TOP CHORDS - 1 ROW, RIPPED 2x4'S - 2 ROWS: SPACED @ 4" O.C. USE 2" MEMBER END DISTANCE.

ATTACH 1/2" PLYWOOD OR OSB GUSSET (15/32" RATED SHEATHING 3/16 EXP 1) TO ONE FACE OF TRUSS WITH CONSTRUCTION QUALITY ADHESIVE AND (3) (0.113" X 2") NAILS INTO EACH CHORD AS SHOWN (TOTAL - 6 NAILS PER GUSSET).

Plate Offsets (X,Y)-- [1:0-6-0,0-0-2], [7:0-6-0,0-0-2]

LOADING (psf)	SPACING-	CSI.	DEFL.	in (loc)	l/defl	L/d	PLATES	GRIP
TCLL (roof) 20.0	2-0-0	TC 0.62	Vert(LL)	-0.11 9-17	>999	380	MT20	244/190
Snow (Pf/Pg) 15.4/20.0	Plate Grip DOL 1.15	BC 0.56	Vert(CT)	-0.23 11-14	>999	240		
TCDL 10.0	Lumber DOL 1.15	WB 0.33	Horz(CT)	0.03 7	n/a	n/a		
BCLL 0.0	Rep Stress Incr YES	Matrix-AS	Wind(LL)	0.04 11-14	>999	240	Weight: 183 lb	FT = 20%
BCDL 10.0	Code IRC2015/TPI2014							

LUMBER-	BRACING-
TOP CHORD 2x4 SP No.2	TOP CHORD Structural wood sheathing directly applied.
BOT CHORD 2x6 SP No.2	BOT CHORD Rigid ceiling directly applied.
WEBS 2x4 SP No.3	

REACTIONS. (lb/size) 1=1109/Mechanical, 7=1154/0-3-8
 Max Horz 1=168(LC 12)
 Max Grav 1=1318(LC 26), 7=1366(LC 27)

FORCES. (lb) - Max. Comp./Max. Ten. - All forces 250 (lb) or less except when shown.
 TOP CHORD 1-2=-1879/81, 2-4=-1690/140, 4-8=-1687/138, 6-7=-1877/77
 BOT CHORD 1-11=0/1596, 9-11=0/1057, 7-9=0/1476
 WEBS 4-9=-127/98, 6-9=-430/154, 4-11=-14/801, 2-11=-431/154

- NOTES-
- 1) Unbalanced roof live loads have been considered for this design.
 - 2) Wind: ASCE 7-10; Vult=115mph (3-second gust) Vasd=91mph; TCCL=6.0psf; BCCL=6.0psf; h=25ft; Cat. II; Exp B; Enclosed; MWFRS (envelope) and C-C Exterior(2) 0-0-0 to 3-1-10, Interior(1) 3-1-10 to 15-8-0, Exterior(2) 15-8-0 to 18-9-10, Interior(1) 18-9-10 to 32-2-8 zone; cantilever left and right exposed; C-C for members and forces & MWFRS for reactions shown; Lumber DOL=1.60 plate grip DOL=1.60
 - 3) TCCL: ASCE 7-10; Pr=20.0 psf (roof live load; Lumber DOL=1.15 Plate DOL=1.15); Pg=20.0 psf (ground snow); Pf=15.4 psf (flat roof snow; Lumber DOL=1.15 Plate DOL=1.15); Category II; Exp B; Partially Exp.; Ct=1.10
 - 4) This truss has been designed for greater of min roof live load of 12.0 psf or 1.00 times flat roof load of 15.4 psf on overhangs non-concurrent with other live loads.
 - 5) This truss has been designed for a 10.0 psf bottom chord live load nonconcurrent with any other live loads.
 - 6) * This truss has been designed for a live load of 20.0psf on the bottom chord in all areas where a rectangle 3-6-0 tall by 2-0-0 wide will fit between the bottom chord and any other members, with BCCL = 10.0psf.
 - 7) Refer to girder(s) for truss to truss connections.
 - 8) This design requires that a minimum of 7/16" structural wood sheathing be applied directly to the top chord and 1/2" gypsum sheetrock be applied directly to the bottom chord.

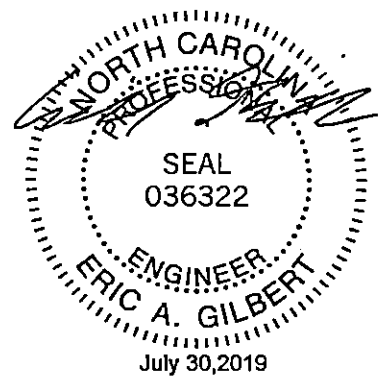

WARNING - Verify design parameters and READ NOTES ON THIS AND INCLUDED MITEK REFERENCE PAGE M0-7473 rev. 10/03/2015 BEFORE USE.
 Design valid for use only with MiTek® connectors. This design is based only upon parameters shown, and is for an individual building component, not a truss system. Before use, the building designer must verify the applicability of design parameters and properly incorporate this design into the overall building design. Bracing indicated is to prevent buckling of individual truss web and/or chord members only. Additional temporary and permanent bracing is always required for stability and to prevent collapse with possible personal injury and property damage. For general guidance regarding the fabrication, storage, delivery, erection and bracing of trusses and truss systems, see ANSITPP1 Quality Criteria, DSB-89 and BCSI Building Component Safety Information available from Truss Plate Institute, 218 N. Lee Street, Suite 312, Alexandria, VA 22314.

ENGINEERED BY
TRENCO
 A MiTek Affiliate
 818 Soundside Road
 Edenton, NC 27932

Symbols

PLATE LOCATION AND ORIENTATION

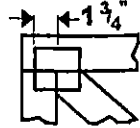

Center plate on joint unless x, y offsets are indicated. Dimensions are in ft-in-sixteenths. Apply plates to both sides of truss and fully embed teeth.

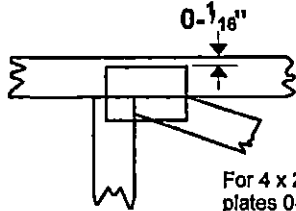

For 4 x 2 orientation, locate plates 0- 1/16" from outside edge of truss.



This symbol indicates the required direction of slots in connector plates.

* Plate location details available in MITek 20/20 software or upon request.

PLATE SIZE

4 x 4

The first dimension is the plate width measured perpendicular to slots. Second dimension is the length parallel to slots.

LATERAL BRACING LOCATION



Indicated by symbol shown and/or by text in the bracing section of the output. Use T or I bracing if indicated.

BEARING

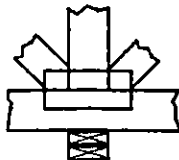

Indicates location where bearings (supports) occur. Icons vary but reaction section indicates joint number where bearings occur. Min size shown is for crushing only.

Industry Standards:

- ANSI/TPI1: National Design Specification for Metal Plate Connected Wood Truss Construction.
- DSB-89: Design Standard for Bracing.
- BCSI: Building Component Safety Information, Guide to Good Practice for Handling, Installing & Bracing of Metal Plate Connected Wood Trusses.

Numbering System

6-4-8 dimensions shown in ft-in-sixteenths (Drawings not to scale)

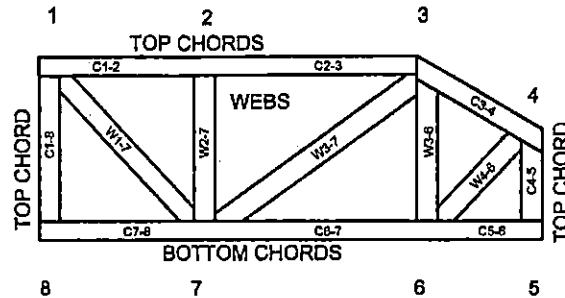

JOINTS ARE GENERALLY NUMBERED/LETTERED CLOCKWISE AROUND THE TRUSS STARTING AT THE JOINT FARTHEST TO THE LEFT.

CHORDS AND WEBS ARE IDENTIFIED BY END JOINT NUMBERS/LETTERS.

PRODUCT CODE APPROVALS

ICC-ES Reports:

ESR-1311, ESR-1352, ESR1988
ER-3907, ESR-2362, ESR-1397, ESR-3282

Trusses are designed for wind loads in the plane of the truss unless otherwise shown.

Lumber design values are in accordance with ANSI/TPI 1 section 6.3 These truss designs rely on lumber values established by others.

© 2012 MITek® All Rights Reserved



MITek Engineering Reference Sheet: MII-7473 rev. 10/03/2015



General Safety Notes

Failure to Follow Could Cause Property Damage or Personal Injury

1. Additional stability bracing for truss system, e.g. diagonal or X-bracing, is always required. See BCSI.
2. Truss bracing must be designed by an engineer. For wide truss spacing, individual lateral braces themselves may require bracing, or alternative Tor I bracing should be considered.
3. Never exceed the design loading shown and never stack materials on inadequately braced trusses.
4. Provide copies of this truss design to the building designer, erection supervisor, property owner and all other interested parties.
5. Cut members to bear tightly against each other.
6. Place plates on each face of truss at each joint and embed fully. Knots and wane at joint locations are regulated by ANSI/TPI 1.
7. Design assumes trusses will be suitably protected from the environment in accord with ANSI/TPI 1.
8. Unless otherwise noted, moisture content of lumber shall not exceed 19% at time of fabrication.
9. Unless expressly noted, this design is not applicable for use with fire retardant, preservative treated, or green lumber.
10. Camber is a non-structural consideration and is the responsibility of truss fabricator. General practice is to camber for dead load deflection.
11. Plate type, size, orientation and location dimensions indicated are minimum plating requirements.
12. Lumber used shall be of the species and size, and in all respects, equal to or better than that specified.
13. Top chords must be sheathed or purlins provided at spacing indicated on design.
14. Bottom chords require lateral bracing at 10 ft. spacing, or less, if no ceiling is installed, unless otherwise noted.
15. Connections not shown are the responsibility of others.
16. Do not cut or alter truss member or plate without prior approval of an engineer.
17. Install and load vertically unless indicated otherwise.
18. Use of green or treated lumber may pose unacceptable environmental, health or performance risks. Consult with project engineer before use.
19. Review all portions of this design (front, back, words and pictures) before use. Reviewing pictures alone is not sufficient.
20. Design assumes manufacture in accordance with ANSI/TPI 1 Quality Criteria.