

Trenco
818 Soundside Rd
Edenton, NC 27932

Re: 19020128_-_FAIRCLOTH
Faircloth

The truss drawing(s) referenced below have been prepared by Truss Engineering Co. under my direct supervision based on the parameters provided by Carter Components (Sanford, NC)).

Pages or sheets covered by this seal: E13140701 thru E13140703

My license renewal date for the state of North Carolina is December 31, 2019.

North Carolina COA: C-0844



June 10, 2019

Strzyzewski, Marvin

IMPORTANT NOTE: The seal on these truss component designs is a certification that the engineer named is licensed in the jurisdiction(s) identified and that the designs comply with ANSI/TPI 1. These designs are based upon parameters shown (e.g., loads, supports, dimensions, shapes and design codes), which were given to MiTek or TRENCO. Any project specific information included is for MiTek's or TRENCO's customers file reference purpose only, and was not taken into account in the preparation of these designs. MiTek or TRENCO has not independently verified the applicability of the design parameters or the designs for any particular building. Before use, the building designer should verify applicability of design parameters and properly incorporate these designs into the overall building design per ANSI/TPI 1, Chapter 2.

Job	Truss	Truss Type	Qty	Ply	Faircloth	E13140701
19020128_-_FAIRCLOTH	J4-HDR	Jack-Open	25	1		

Carter Components (Sanford), Sanford, NC - 27332,

8.220 s Nov 16 2018 MiTek Industries, Inc. Fri Jun 7 10:06:07 2019 Page 1

ID:eYg8v1rH8RtdNFhcZ8D6euzalE4-6?3OfCx7I_c4oDBPHmJeOfBZR6eop?77xuh0Nsz8icU

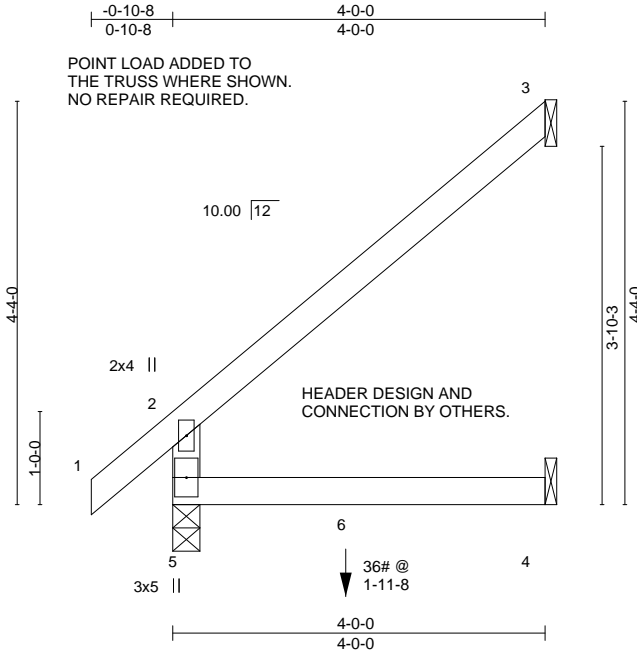

Scale = 1:24.8

LOADING (psf)	SPACING-	CSI.	DEFL.	PLATES	GRIP
TCLL (roof) 20.0	2-0-0	TC 0.36	in (loc) l/defl L/d	MT20	244/190
Snow (Pf/Pg) 13.9/20.0	Plate Grip DOL 1.15	BC 0.24	Vert(LL) 0.02 4-5 >999 240		
TCDL 10.0	Lumber DOL 1.15	WB 0.00	Vert(CT) -0.03 4-5 >999 180		
BCLL 0.0 *	Rep Stress Incr NO	Matrix-MR	Horz(CT) 0.03 3 n/a n/a		
BCDL 10.0	Code IRC2015/TPI2014			Weight: 17 lb	FT = 20%

LUMBER-	BRACING-
TOP CHORD 2x4 SP No.2	TOP CHORD Sheathed or 4-0-0 oc purlins, except end verticals.
BOT CHORD 2x4 SP No.2	BOT CHORD Rigid ceiling directly applied or 10-0-0 oc bracing.
WEBS 2x4 SP No.3	

REACTIONS. (lb/size) 5=202/0-3-8, 3=82/Mechanical, 4=57/Mechanical
 Max Horz 5=98(LC 13)
 Max Uplift 3=-62(LC 13)
 Max Grav 5=243(LC 2), 3=116(LC 25), 4=69(LC 25)

FORCES. (lb) - Max. Comp./Max. Ten. - All forces 250 (lb) or less except when shown.

- NOTES-**
- 1) Wind: ASCE 7-10; Vult=130mph (3-second gust) Vasd=103mph; TCDL=6.0psf; BCDL=6.0psf; h=25ft; Cat. II; Exp B; Enclosed; MWFRS (envelope) and C-C Exterior(2) zone; cantilever left and right exposed; end vertical left and right exposed; C-C for members and forces & MWFRS for reactions shown; Lumber DOL=1.60 plate grip DOL=1.33
 - 2) TCLL: ASCE 7-10; Pr=20.0 psf (roof live load: Lumber DOL=1.15 Plate DOL=1.15); Pg=20.0 psf (ground snow); Pf=13.9 psf (flat roof snow: Lumber DOL=1.15 Plate DOL=1.15); Category II; Exp B; Fully Exp.; Ct=1.10
 - 3) This truss has been designed for greater of min roof live load of 12.0 psf or 2.00 times flat roof load of 13.9 psf on overhangs non-concurrent with other live loads.
 - 4) * This truss has been designed for a live load of 20.0psf on the bottom chord in all areas where a rectangle 3-6-0 tall by 2-0-0 wide will fit between the bottom chord and any other members.
 - 5) Refer to girder(s) for truss to truss connections.
 - 6) Provide mechanical connection (by others) of truss to bearing plate capable of withstanding 100 lb uplift at joint(s) 3.
 - 7) Hanger(s) or other connection device(s) shall be provided sufficient to support concentrated load(s) 46 lb down and 10 lb up at 1-11-8 on bottom chord. The design/selection of such connection device(s) is the responsibility of others.
 - 8) In the LOAD CASE(S) section, loads applied to the face of the truss are noted as front (F) or back (B).

LOAD CASE(S) Standard

- 1) Dead + Snow (balanced): Lumber Increase=1.15, Plate Increase=1.15

Uniform Loads (plf)
 Vert: 1-2=-48, 2-3=-48, 4-5=-20

Concentrated Loads (lb)
 Vert: 6=-36(F)

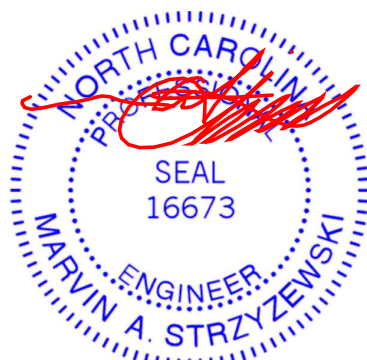

June 10, 2019

Job	Truss	Truss Type	Qty	Ply	Faircloth	E13140702
19020128_-_FAIRCLOTH	J4-CUT	JACK-OPEN	1	1		

Carter Components - Sanford, Sanford, NC

Job Reference (optional)
8.220 s Mar 22 2019 MiTek Industries, Inc. Fri Jun 7 16:03:26 2019 Page 1
ID:eYg8v1rH8RtdNFhcZ8D6euzalE4-f0ITyzTZCKFpw_TZHxBjN2X5173O01Mt0oUF_Oz8eFI

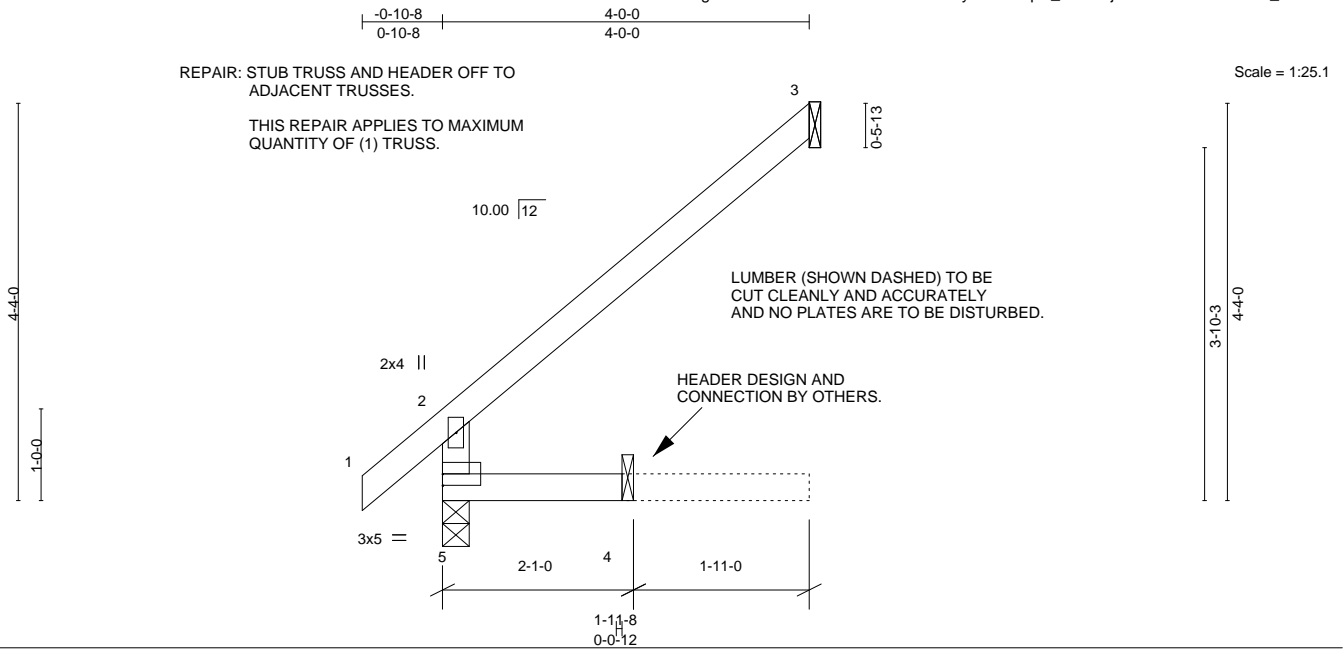

LOADING (psf)	SPACING-	CSI.	DEFL.	PLATES	GRIP
TCLL (roof) 20.0	2-0-0	TC 0.39	in (loc) l/defl L/d	MT20	244/190
Snow (Pf/Pg) 13.9/20.0	Plate Grip DOL 1.15	BC 0.24	Vert(LL) 0.01 4-5 >999 240		
TCDL 10.0	Lumber DOL 1.15	WB 0.00	Vert(CT) -0.01 4-5 >999 180		
BCLL 0.0 *	Rep Stress Incr YES	Matrix-MR	Horz(CT) -0.02 3 n/a n/a		
BCDL 10.0	Code IRC2015/TPI2014			Weight: 14 lb	FT = 20%

LUMBER-

TOP CHORD 2x4 SP No.2
BOT CHORD 2x4 SP No.2
WEBS 2x4 SP No.3

BRACING-

TOP CHORD Sheathed or 4-0-0 oc purlins, except end verticals.
BOT CHORD Rigid ceiling directly applied or 10-0-0 oc bracing.

REACTIONS. (lb/size) 5=155/0-3-8, 3=77/Mechanical, 3=77/Mechanical, 4=36/Mechanical
Max Horz 5=99(LC 13)
Max Uplift 3=61(LC 13), 4=34(LC 13)
Max Grav 5=191(LC 2), 3=108(LC 25), 3=77(LC 1), 4=56(LC 25)

FORCES. (lb) - Maximum Compression/Maximum Tension

TOP CHORD 2-5=-195/62, 1-2=0/49, 2-3=-99/81
BOT CHORD 4-5=0/0

NOTES-

- 1) Wind: ASCE 7-10; Vult=130mph (3-second gust) Vasd=103mph; TCDL=6.0psf; BCDL=6.0psf; h=25ft; Cat. II; Exp B; Enclosed; MWFRS (envelope) and C-C Exterior(2) zone; cantilever left and right exposed; end vertical left and right exposed; C-C for members and forces & MWFRS for reactions shown; Lumber DOL=1.60 plate grip DOL=1.33
- 2) TCLL: ASCE 7-10; Pr=20.0 psf (roof live load: Lumber DOL=1.15 Plate DOL=1.15); Pg=20.0 psf (ground snow); Pf=13.9 psf (flat roof snow: Lumber DOL=1.15 Plate DOL=1.15); Category II; Exp B; Fully Exp.; Ct=1.10
- 3) This truss has been designed for greater of min roof live load of 12.0 psf or 2.00 times flat roof load of 13.9 psf on overhangs non-concurrent with other live loads.
- 4) * This truss has been designed for a live load of 20.0psf on the bottom chord in all areas where a rectangle 3-6-0 tall by 2-0-0 wide will fit between the bottom chord and any other members.
- 5) Refer to girder(s) for truss to truss connections.
- 6) Provide mechanical connection (by others) of truss to bearing plate capable of withstanding 61 lb uplift at joint 3 and 34 lb uplift at joint 4.

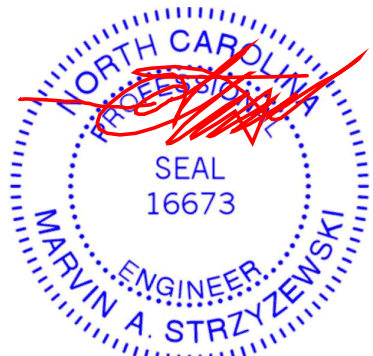

June 10, 2019

WARNING - Verify design parameters and READ NOTES ON THIS AND INCLUDED MITEK REFERENCE PAGE MII-7473 rev. 10/03/2015 BEFORE USE.

Design valid for use only with MiTek® connectors. This design is based only upon parameters shown, and is for an individual building component, not a truss system. Before use, the building designer must verify the applicability of design parameters and properly incorporate this design into the overall building design. Bracing indicated is to prevent buckling of individual truss web and/or chord members only. Additional temporary and permanent bracing is always required for stability and to prevent collapse with possible personal injury and property damage. For general guidance regarding the fabrication, storage, delivery, erection and bracing of trusses and truss systems, see **ANSI/TPI1 Quality Criteria, DSB-89 and BCSI Building Component Safety Information** available from Truss Plate Institute, 218 N. Lee Street, Suite 312, Alexandria, VA 22314.



818 Soundside Road
Edenton, NC 27932

Symbols

PLATE LOCATION AND ORIENTATION

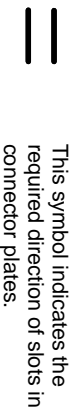
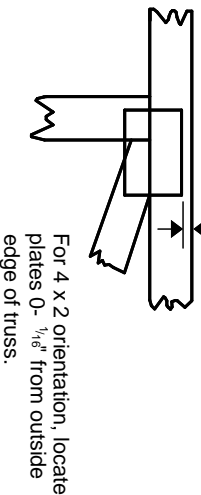
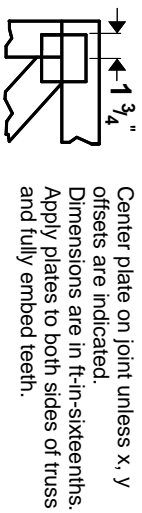

* Plate location details available in **MITrak 20/20 software or upon request.**

PLATE SIZE

4 X 4

The first dimension is the plate width measured perpendicular to slots. Second dimension is the length parallel to slots.

LATERAL BRACING LOCATION



BEARING

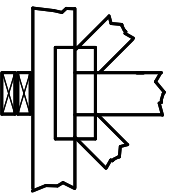

Indicates location where bearings (supports) occur. Icons vary but reaction section indicates joint number where bearings occur. Min size shown is for crushing only.

Industry Standards:

ANSI/TPI 1: National Design Specification for Metal Plate Connected Wood Truss Construction.
DSB-89: Design Standard for Bracing.
BCSI: Building Component Safety Information, Guide to Good Practice for Handling, Installing & Bracing of Metal Plate Connected Wood Trusses.

Numbering System

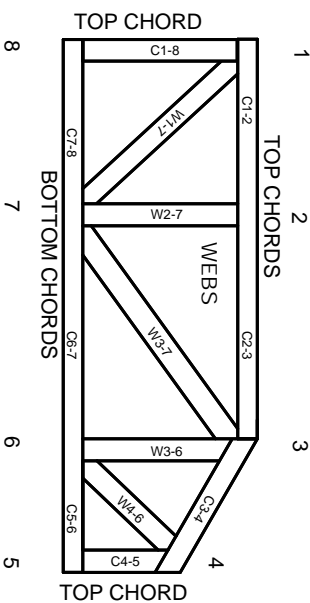

JOINTS ARE GENERALLY NUMBERED/LETTERED CLOCKWISE AROUND THE TRUSS STARTING AT THE JOINT FARTHEST TO THE LEFT.

CHORDS AND WEBS ARE IDENTIFIED BY END JOINT NUMBERS/LETTERS.

PRODUCT CODE APPROVALS

ICC-ES Reports:

ESR-1311, ESR-1352, ESR1988
ER-3907, ESR-2362, ESR-1397, ESR-3282

Trusses are designed for wind loads in the plane of the truss unless otherwise shown.

Lumber design values are in accordance with ANSI/TPI 1 section 6.3 These truss designs rely on lumber values established by others.

© 2012 MITTEK® All Rights Reserved



MITek Engineering Reference Sheet: MII-7473 rev. 10/03/2015



General Safety Notes

Failure to Follow Could Cause Property Damage or Personal Injury

1. Additional stability bracing for truss system, e.g. diagonal or X-bracing, is always required. See BCSI.
2. Truss bracing must be designed by an engineer. For wide truss spacing, individual lateral braces themselves may require bracing, or alternative Tor I bracing should be considered.
3. Never exceed the design loading shown and never stack materials on inadequately braced trusses.
4. Provide copies of this truss design to the building designer, erection supervisor, property owner and all other interested parties.
5. Cut members to bear tightly against each other.
6. Place plates on each face of truss at each joint and embed fully. Knots and wane at joint locations are regulated by ANSI/TPI 1.
7. Design assumes trusses will be suitably protected from the environment in accord with ANSI/TPI 1.
8. Unless otherwise noted, moisture content of lumber shall not exceed 19% at time of fabrication.
9. Unless expressly noted, this design is not applicable for use with fire retardant, preservative treated, or green lumber.
10. Camber is a non-structural consideration and is the responsibility of truss fabricator. General practice is to camber for dead load deflection.
11. Plate type, size, orientation and location dimensions indicated are minimum plating requirements.
12. Lumber used shall be of the species and size, and in all respects, equal to or better than that specified.
13. Top chords must be sheathed or purlins provided at spacing indicated on design.
14. Bottom chords require lateral bracing at 10 ft. spacing, or less, if no ceiling is installed, unless otherwise noted.
15. Connections not shown are the responsibility of others.
16. Do not cut or alter truss member or plate without prior approval of an engineer.
17. Install and load vertically unless indicated otherwise.
18. Use of green or treated lumber may pose unacceptable environmental, health or performance risks. Consult with project engineer before use.
19. Review all portions of this design (front, back, words and pictures) before use. Reviewing pictures alone is not sufficient.
20. Design assumes manufacture in accordance with ANSI/TPI 1 Quality Criteria.