

Builders FirstSource

Boise Cascade

www.bldr.com

1135 ROBESON STREET
FAYETTEVILLE, NC 28305
V (910) 485-1111

7601 BOEING DRIVE
GREENSBORO, NC 27409
V (336) 884-5454

3189 NC HIGHWAY 5
ABERDEEN NC 28315
V (910) 944-2516

This layout and associated materials list has been prepared based on project plans and/or information provided to Builders FirstSource (BFS). It remains the responsibility of the builder, architect, designer, or other responsible persons to review this information to assure that it is appropriate, accurate, complete and complies with applicable building codes.

- GENERAL NOTES:**
- 1.) READ THE INSTALLATION GUIDE BEFORE FRAMING.
 - 2.) ALL WALLS SHOWN ARE LOAD BEARING UNLESS NOTED OTHERWISE. WALLS NOT SHOWN ARE CONSIDERED NON-LOAD BEARING.
 - 3.) UNLESS STATED OTHERWISE ALL CEILING & ROOF LOADS BRACE DIRECTLY TO LOAD BEARING WALLS SUPPORTED BY FOUNDATION.
 - 4.) CONTACT BUILDERS FIRSTSOURCE BEFORE MAKING ANY ALTERATIONS OR ADJUSTMENTS...FAILURE TO DO SO MAY RESULT IN COSTLY REPAIRS.

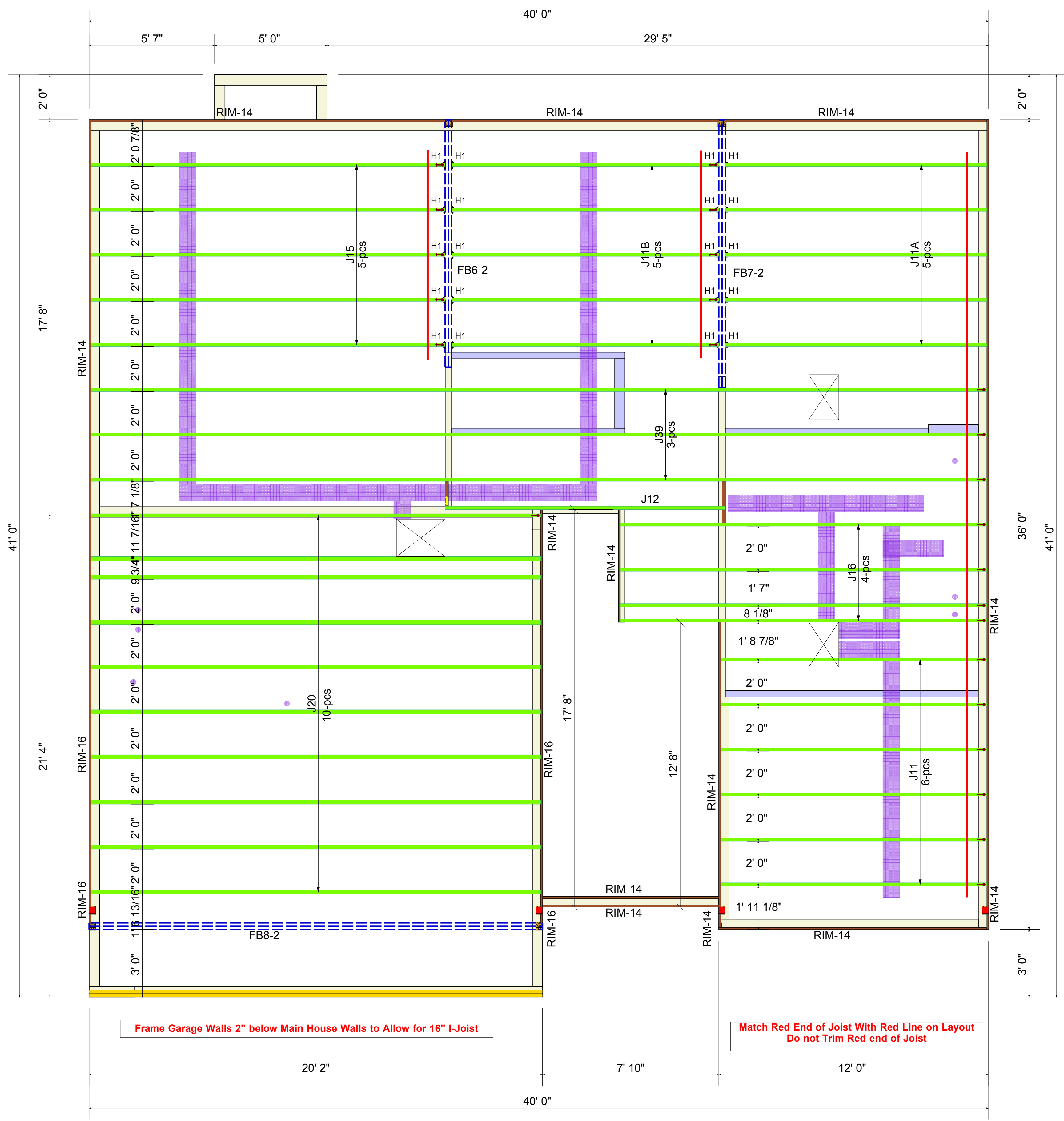

HATTERAS
SEAL DATE 01/27/16
2nd FLOOR EWP PLACEMENT PLAN

PlotID	Length	Products		Plies	Net Qty
		Product	Qty		
J39	39' 10"	14" BCI® 4500s-1.8	1	3	
J20	20' 0"	14" BCI® 4500s-1.8	1	1	
J16	16' 3 1/2"	14" BCI® 4500s-1.8	1	4	
J15	15' 9"	14" BCI® 4500s-1.8	1	5	
J12	12' 5 1/2"	14" BCI® 4500s-1.8	1	1	
J11B	11' 10 1/2"	14" BCI® 4500s-1.8	1	5	
J11	11' 10"	14" BCI® 4500s-1.8	1	6	
J11A	11' 7 1/2"	14" BCI® 4500s-1.8	1	5	
J20	20' 0"	16" BCI® 60s-2.0	1	9	
FB6-2	12' 0"	1-3/4" x 14" VERSA-LAM® 2.0 3100 SP	2	2	
FB7-2	12' 0"	1-3/4" x 14" VERSA-LAM® 2.0 3100 SP	2	2	
FB8-2	22' 0"	1-3/4" x 16" VERSA-LAM® 2.0 3100 SP	2	2	
RIM-14	12' 0"	1" x 14" BC RIM BOARD OSB	1	12	
RIM-16	12' 0"	1" x 16" BC RIM BOARD OSB	1	3	
BK	2' 0"	14" BCI® 4500s-1.8	1	2	
OPT SIDE DOOR*	8' 0"	1-3/4" x 9-1/4" LVL	1	1	

Hangers

PlotID	Qty	Manuf	Product
H1	20	Simpson	IUS 1.81/14

Frame Garage Walls 2" below Main House Walls to Allow for 16" I-Joist

Match Red End of Joist With Red Line on Layout
Do not Trim Red end of Joist

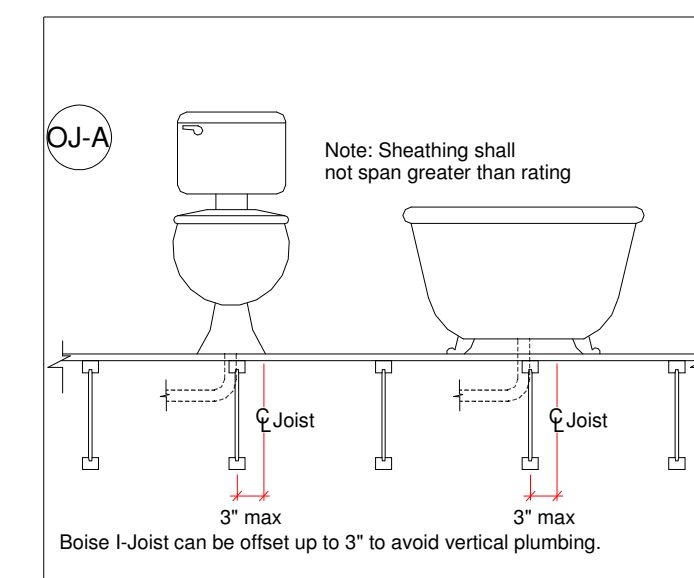

H & H HOMES

HATTERAS - MASTER

2nd FLOOR EWP PLACEMENT PLAN

Builders FirstSource, Central Carolina Markets

DRAWN BY: LEE ATKINS DATE: 1-4-17

SCALE: NOT TO SCALE

JOB NUMBER:

MINIMUM DESIGN DATA

LIVE LOAD 40 PSF
DEAD LOAD 10 PSF

TOTAL LOAD 50 PSF

DOL = 100%

DEFLECTION CRITERIA
L/480 (MINIMUM)

ARCHITECTURAL PLAN DATE
12-4-15

SEAL DATE
1-27-16

Sheet
1 of 1