

Products				
PlotID	Length	Product	Plies	Net Qty
FJ-27	27' 10"	11-7/8" BCI@ 4500s-1.8	1	8
FJ-24	24' 4"	11-7/8" BCI@ 4500s-1.8	1	2
FJ-15	15' 9 1/4"	11-7/8" BCI@ 4500s-1.8	1	2
FJ-15	15' 6"	11-7/8" BCI@ 4500s-1.8	1	13
FJ-15-2	15' 6"	11-7/8" BCI@ 4500s-1.8	2	4
Rim1	12' 0"	1" x 11-7/8" BC RIM BOARD OSB	1	11

**Builders FirstSource**  
 Engineered Wood Products  
 Boise Cascade  
 www.BLDR.com  
 1135 Robeson St.  
 Fayetteville, NC 28305  
 V (910) 485-1111  
 F (910) 485-6475  
 7601 BOEING DRIVE  
 GREENSBORO, NC 27409  
 V: 336.884.5454

3189 NC HIGHWAY 5  
 ABERDEEN NC 28315  
 V: 910.944.2516

This layout and associated materials list has been prepared based on project plans and/or information provided to Builders FirstSource (BFS). It remains the responsibility of the builder, architect, designer, or other responsible persons to review this information to assure that it is appropriate, accurate, complete and complies with applicable building codes.

- GENERAL NOTES
- 1.) READ THE INSTALLATION GUIDE BEFORE FRAMING
  - 2.) ALL WALLS SHOWN ARE LOAD BEARING UNLESS NOTES OTHERWISE WALLS NOT SHOWN HAVE BEEN CONSIDERED NON-LOAD BEARING
  - 3.) UNLESS STATED OTHERWISE ALL CEILING & ROOF LOADS BRACE DIRECTLY TO LOAD BEARING WALLS SUPPORTED BY FOUNDATION
  - 4.) CONTACT YOUR LOCAL BUILDERS FIRSTSOURCE LOCATION BEFORE MAKING ANY ALTERATION & ADJUSTMENTS. FAILURE MAY RESULT IN COSTLY REPAIRS

<b>H &amp; H HOMES</b>	<b>ENGAGE-A GL</b>	CRAWL EWP PLACEMENT PLAN	Builders FirstSource, Central Carolina Markets	DATE: 3-20-18	JOB #
			DRAWN BY: LEE ATKINS	SCALE: NTS	

MINIMUM DESIGN DATA
LIVE LOAD 40 PSF DEAD LOAD 10 PSF
TOTAL LOAD 50 PSF
STRESS DURATION = 100%
DEFLECTION CRITERIA L/480 (MINIMUM)
ARCHITECTURAL PLAN DATE 11-16-17
REVISED ARCH. PLAN DATE XX-XX-XX
SEALED PLAN DATE 12-22-17

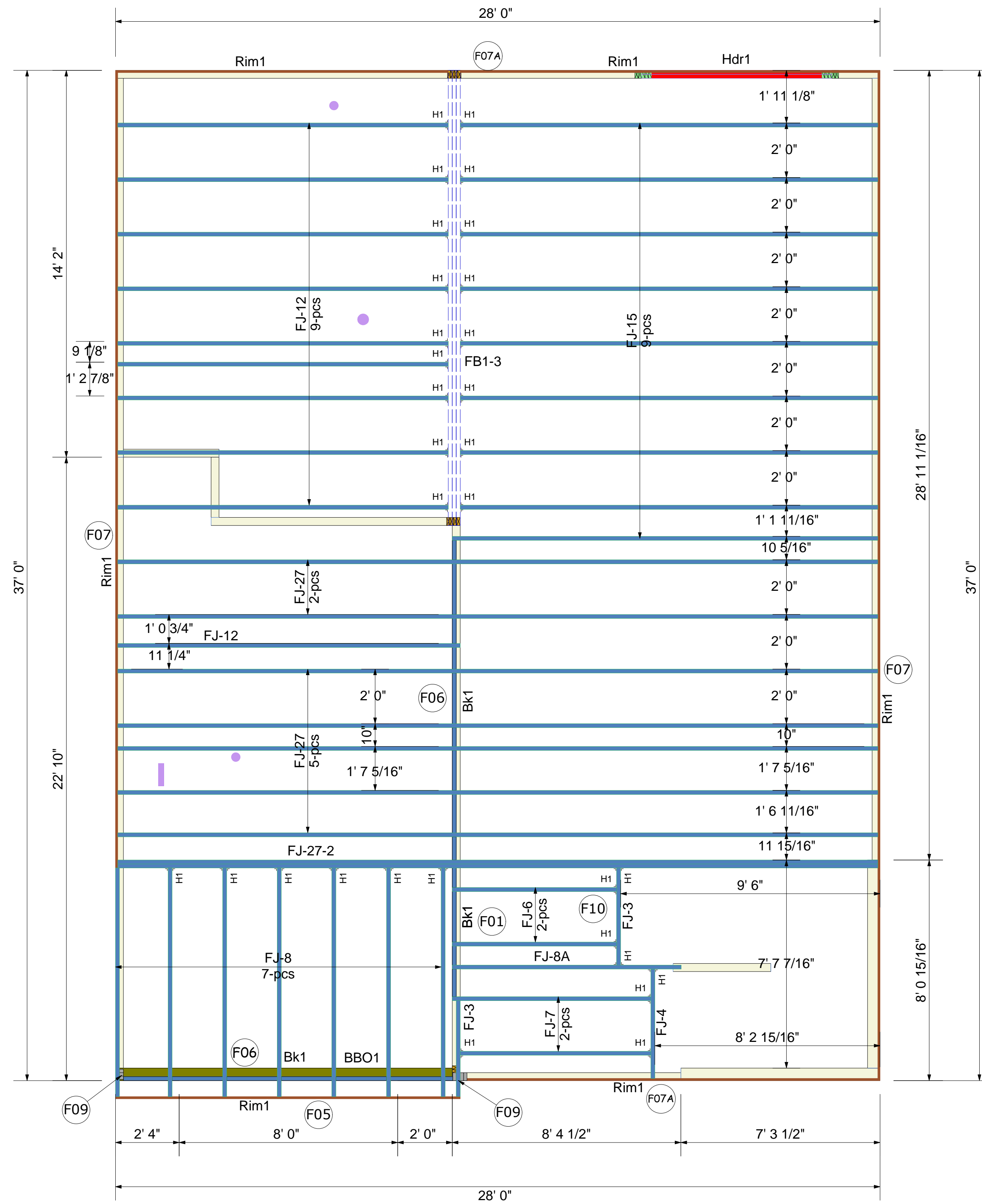
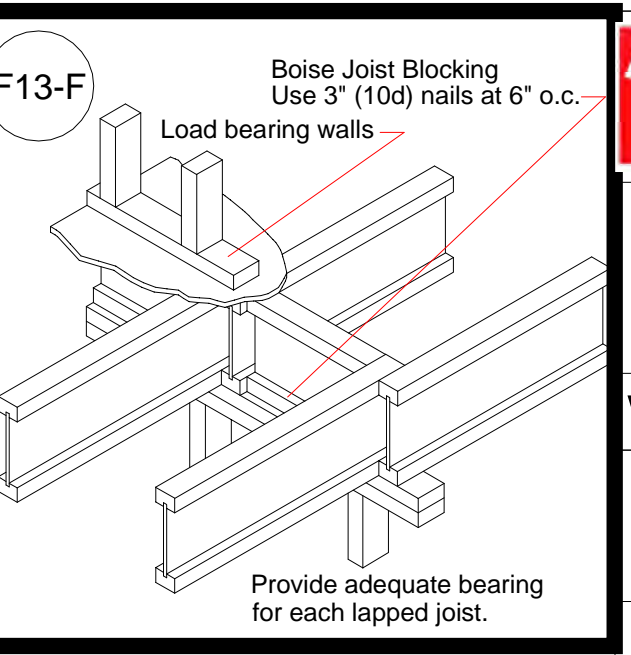
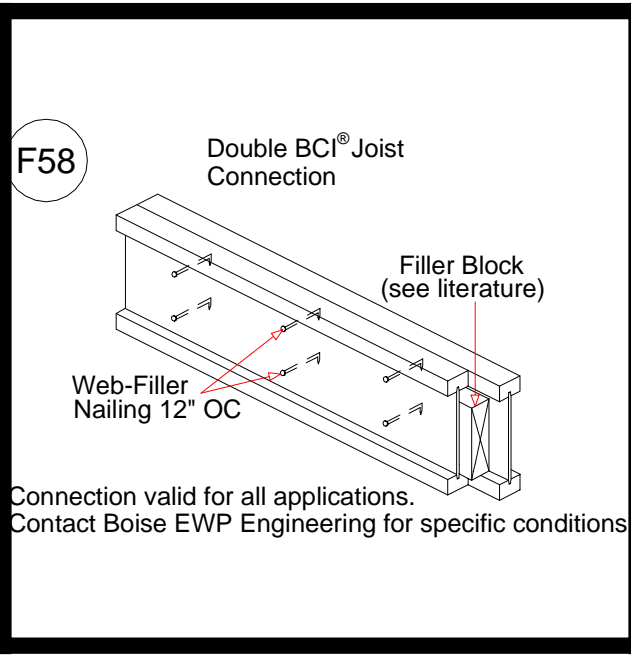
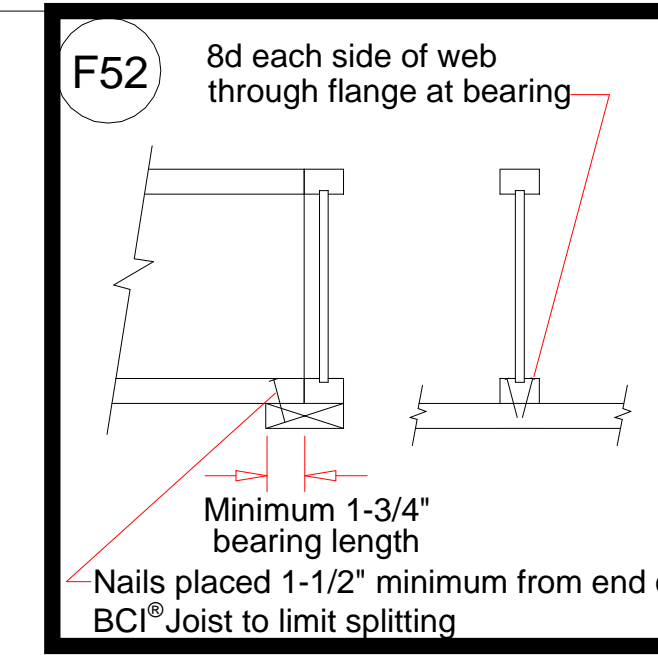
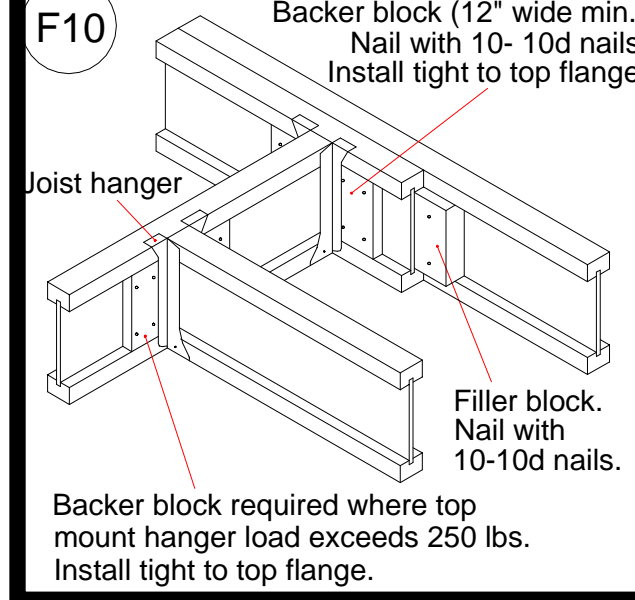
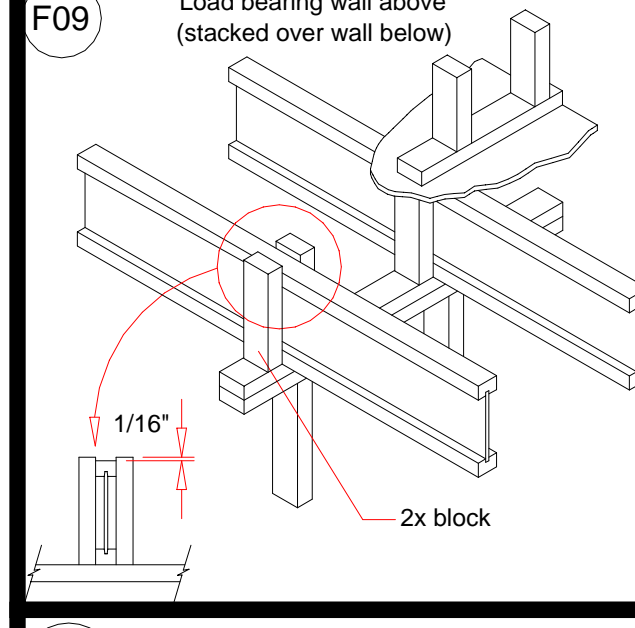
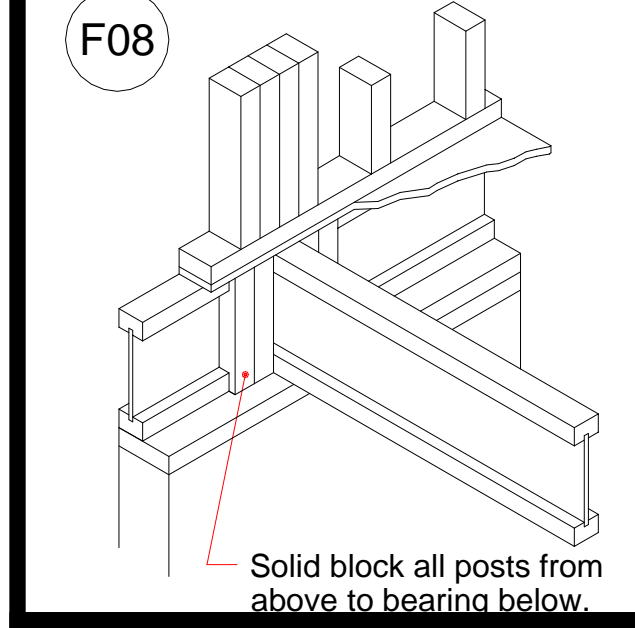
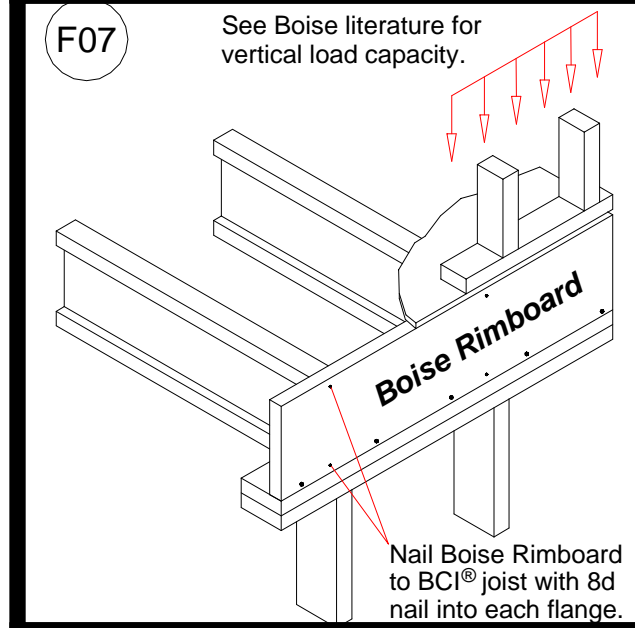
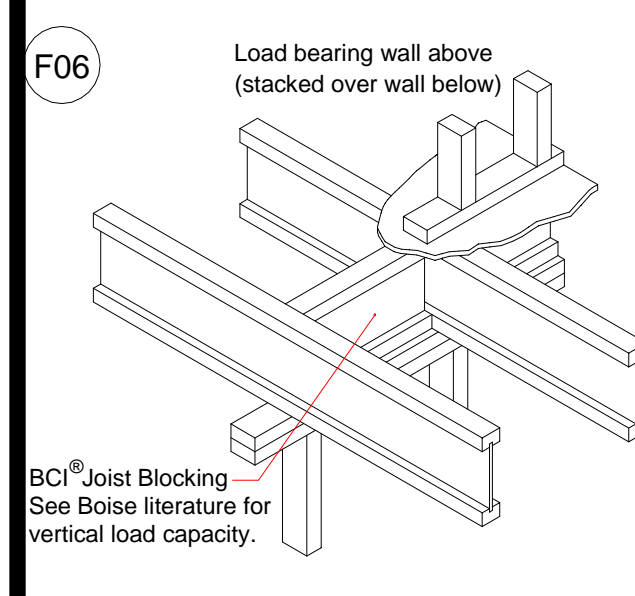
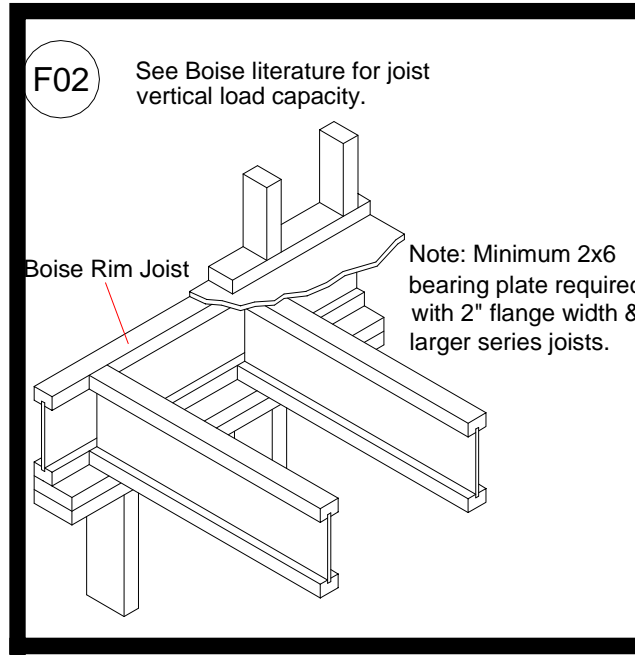

Products				
PlotID	Length	Product	Plies	Net Qty
FJ-27	27' 10"	14" BCI® 4500s-1.8	1	7
FJ-27-2	27' 10"	14" BCI® 4500s-1.8	2	2
FJ-15	15' 7"	14" BCI® 4500s-1.8	1	1
FJ-15	15' 3 3/4"	14" BCI® 4500s-1.8	1	5
FJ-15	15' 3 1/2"	14" BCI® 4500s-1.8	1	3
FJ-12	12' 6 1/2"	14" BCI® 4500s-1.8	1	1
FJ-12	12' 1 1/4"	14" BCI® 4500s-1.8	1	9
FJ-8A	8' 4 3/4"	14" BCI® 4500s-1.8	1	1
FJ-8	8' 4 1/2"	14" BCI® 4500s-1.8	1	7
FJ-7	7' 3 1/2"	14" BCI® 4500s-1.8	1	1
FJ-7	7' 0"	14" BCI® 4500s-1.8	1	1
FJ-6	6' 0 1/4"	14" BCI® 4500s-1.8	1	2
FJ-4	4' 0"	14" BCI® 4500s-1.8	1	1
FJ-3	3' 6 3/4"	14" BCI® 4500s-1.8	1	1
FJ-3	3' 6 1/4"	14" BCI® 4500s-1.8	1	1
FB1-3	18' 0"	1-3/4" x 14" VERSA-LAM® 2.0 3100 SP	3	3
Rim1	12' 0"	1" x 14" BC RIM BOARD OSB	1	11
Bk1	2' 0"	14" BCI® 4500s-1.8	1	14

Wall Framing				
PlotID	Length	Product	Plies	Net Qty
Hdr1	8' 0"	1-3/4" x 9-1/4" VERSA-LAM® 2.0 3100 SP	2	2

Hangers			
PlotID	Qty	Manuf	Product
H1	31	Simpson	IUS 1.81/14

**Boise Cascade**  
Engineered Wood Products

[www.BLDR.com](http://www.BLDR.com)

1135 Robeson St.  
Fayetteville, NC 28305  
V (910) 485-1111  
F (910) 485-6475

7601 BOEING DRIVE  
GREENSBORO, NC 27409  
V: 336.884.5454

3189 NC HIGHWAY 5  
ABERDEEN NC 28315  
V: 910.944.2516

This layout and associated materials list has been prepared based on project plans and/or information provided to Builders FirstSource (BFS). It remains the responsibility of the builder, architect, designer, or other responsible persons to review this information to assure that it is appropriate, accurate, complete and complies with applicable building codes.

**GENERAL NOTES**

- 1.) READ THE INSTALLATION GUIDE BEFORE FRAMING
- 2.) ALL WALL SHOWN ARE LOAD BEARING UNLESS NOTES OTHERWISE WALLS NOT SHOWN HAVE BEEN CONSIDERED NON-LOAD BEARING
- 3.) UNLESS STATED OTHERWISE ALL CEILING & ROOF LOADS BRACE DIRECTLY TO LOAD BEARING WALLS SUPPORTED BY FOUNDATION
- 4.) CONTACT YOUR LOCAL BUILDERS FIRSTSOURCE LOCATION BEFORE MAKING ANY ALTERATION & ADJUSTMENTS. FAILURE MAY RESULT IN COSTLY REPAIRS

<b>H &amp; H HOMES</b>	<b>ENGAGE-A GL</b>	2nd FLOOR EWP PLACEMENT PLAN	Job #
Builders FirstSource, Central Carolina Markets	DATE: 3-20-18		
DRAWN BY: LEE ATKINS	SCALE: NTS		

MINIMUM DESIGN DATA

LIVE LOAD 40 PSF  
DEAD LOAD 10 PSF

TOTAL LOAD 50 PSF

STRESS DURATION = 100%

DEFLECTION CRITERIA  
L/480 (MINIMUM)

ARCHITECTURAL PLAN DATE  
11-16-17

REVISED ARCH. PLAN DATE  
XX-XX-XX

SEALED PLAN DATE  
12-22-17

**Sheet**

1 of 1