

NOTICE TO CONTRACTOR
All construction must comply with current NC Building Codes
and is subject to field inspection and verification.

APPROVED
Limited building only review
Permit holder responsible for
full compliance with the code

05/04/2020

B. Griffin

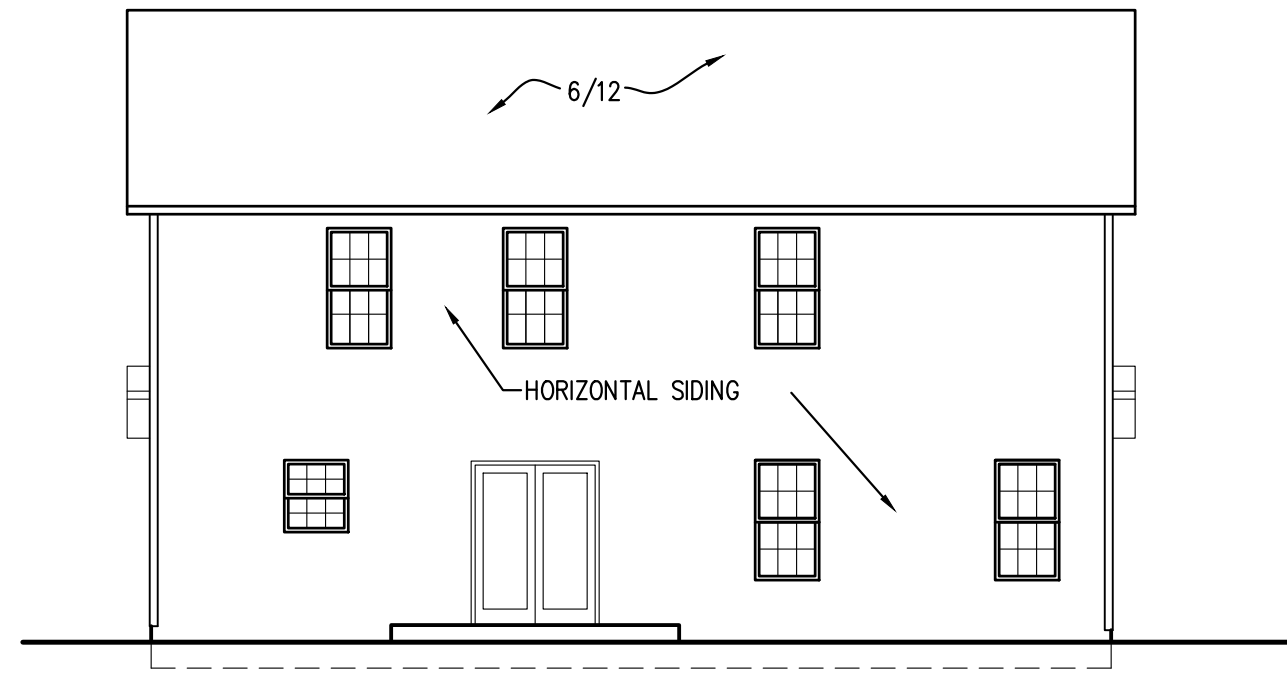

REAR ELEVATION
1/8" = 1'-0"

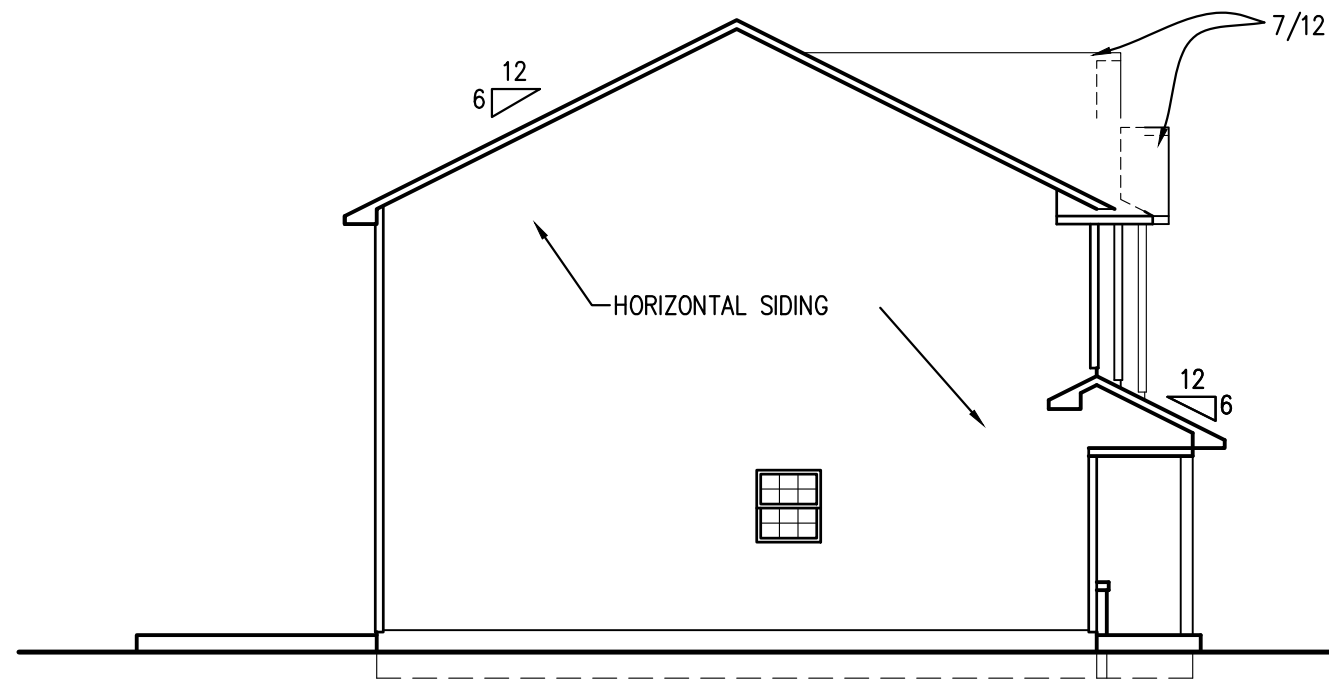

LEFT ELEVATION
1/8" = 1'-0"

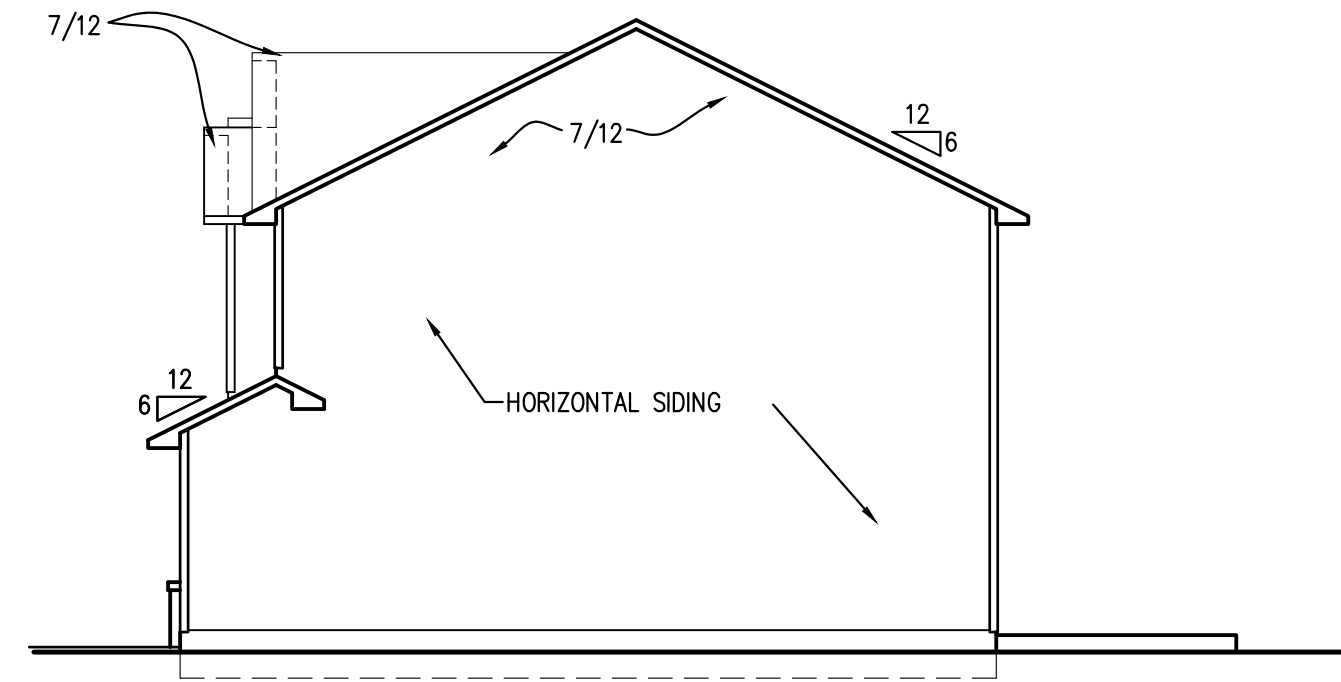

RIGHT ELEVATION
1/8" = 1'-0"

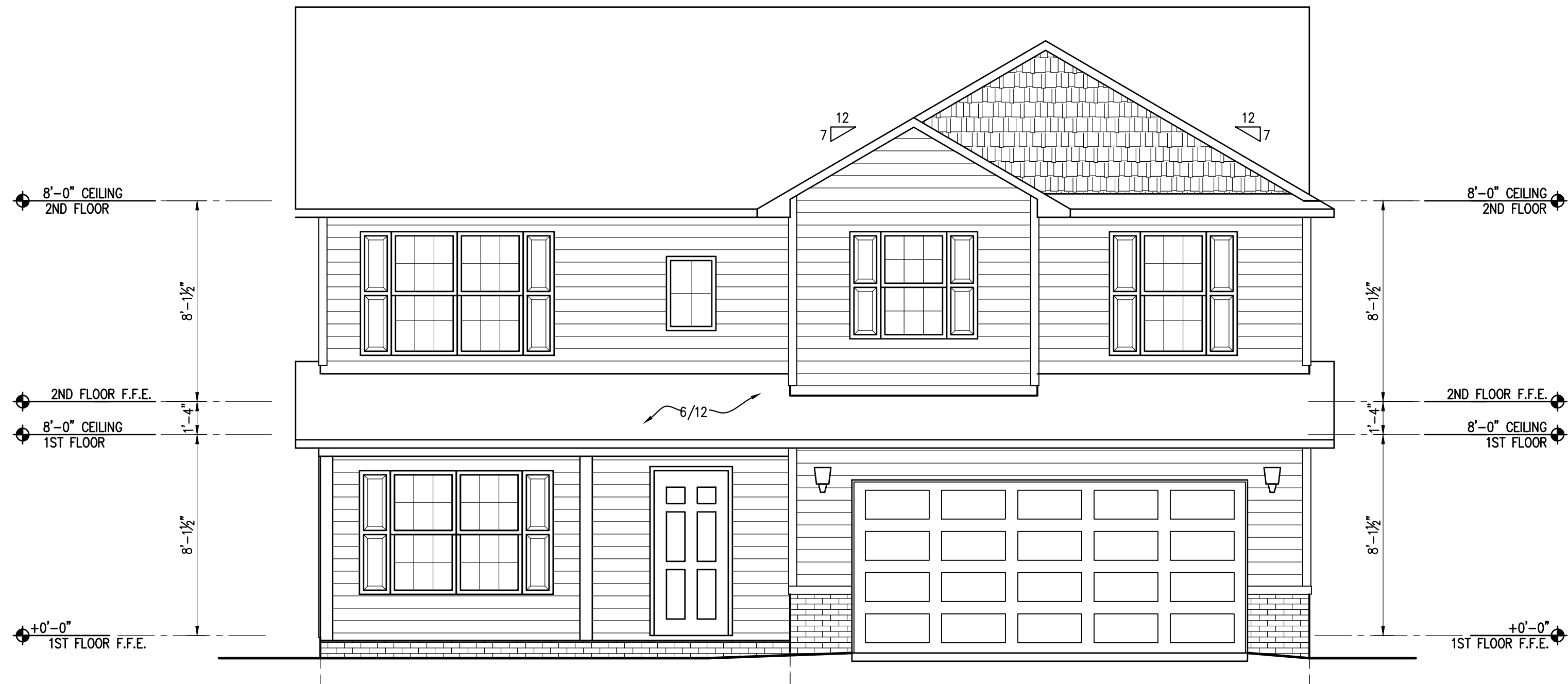

FRONT ELEVATION
1/4" = 1'-0"

The design and plans are the sole property of Ivercon Inc. These drawings are provided for the construction of a single house, for the exclusive use of this client, on the lot, designated herein. The documents may not be copied in any way without written consent.

OUR HAMPTON DESIGN
LOT #:
Subdivision:

IVERCON, INC.
PO Box 64778 910-237-3461-ph
Fayetteville, NC 28306 910-717-5076-fax

USE UPDATED FOOTING PLAN

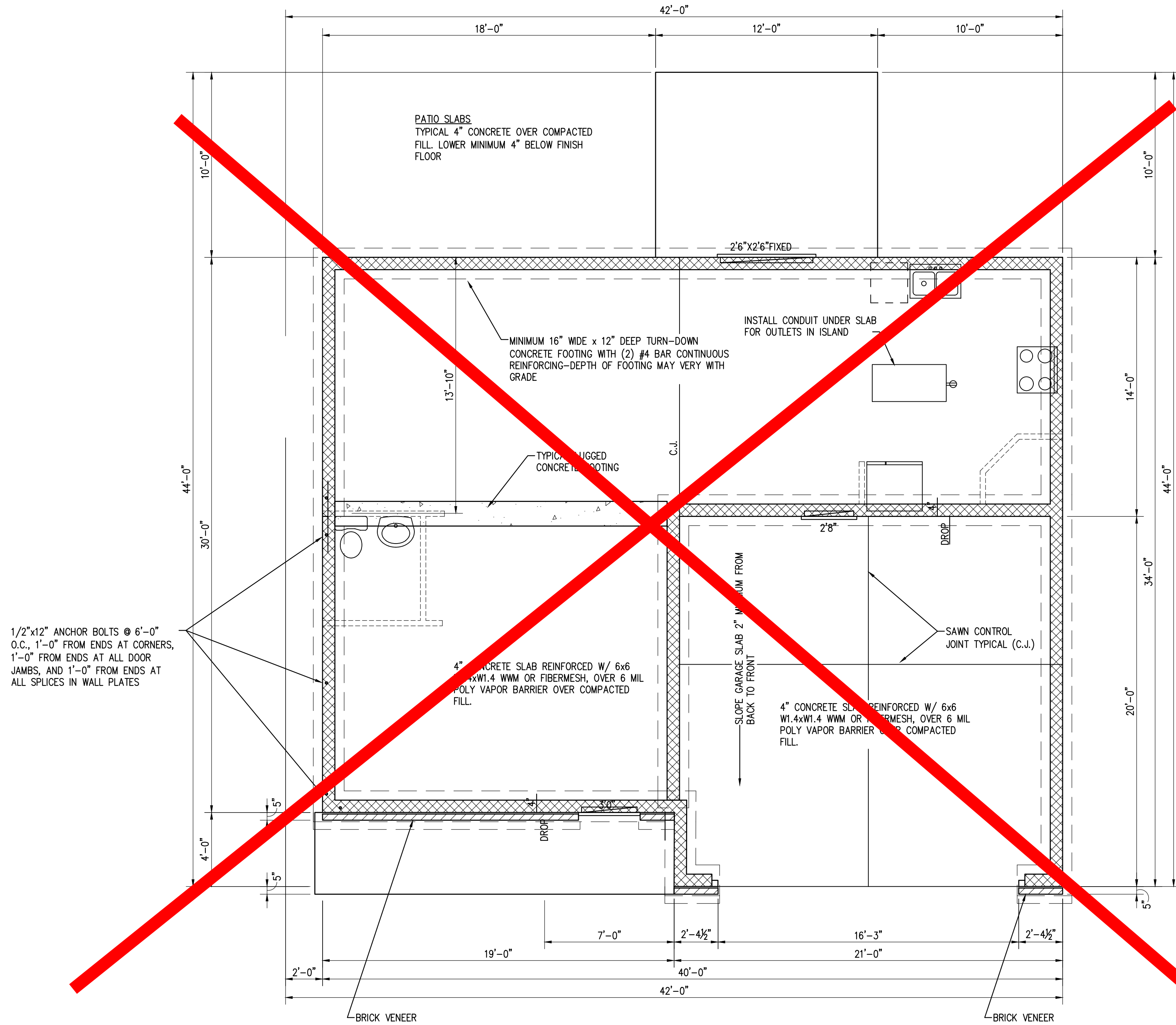

FOUNDATION PLAN
1/4" = 1'-0"

PORCH SLABS
TYPICAL 4" CONCRETE MONOLITHIC SLAB OVER COMPACTED FILL. LOWER MINIMUM 4" BELOW FINISH FLOOR

The design and plans are the sole property of Ivercon Inc. These drawings are provided for the construction of a single house, for the exclusive use of this client, on the lot, designated herein. The documents may not be copied in any way without written consent.

OUR HAMPTON DESIGN
LOT #:
Subdivision:

IVERCON, INC.
PO Box 64778
Fayetteville, NC 28306

THE CONTRACTOR IS RESPONSIBLE FOR VERIFYING ALL DIMENSIONS AND BRING THE ATTENTION OF THE DESIGNER AS SOON AS IS PRACTICAL. THE CONTRACTOR IS REQUIRED TO MAKE ALL NECESSARY ADJUSTMENTS TO THE FOUNDATION CONSTRUCTION AS IS REQUIRE TO ADAPT TO THE SITE CONDITIONS.

FIXTURE / DEVISE LEGEND

	CEILING FAN		SMOKE DETECTOR		WALL OUTLET
	CEILING FAN WITH LIGHT		EXHAUST FAN		220 VOLT OUTLET
	CEILING-MOUNTED FLUORESCENT LIGHT		EXHAUST FAN W/ LIGHT		GROUND-FAULT OUTLET
	CEILING-MOUNTED LIGHT		TELEPHONE JACK		QUADRAPLEX WALL OUTLET
	6" FLUSH MOUNT ROUND LED		DOOR BELL		WATER PROOF OUTLET
	4" FLUSH MOUNT ROUND LED		CABLE JACK		OUTLET MOUNTED @ 44" AFF (ALL OUTLETS AT CABINETS)
	WALL-MOUNTED LIGHT		THERMOSTAT		DUPLEX OUTLET W/DUPLEX USB
	RECESSED DIRECTIONAL LIGHT		FLOOR OUTLET		STACKED DOUBLE SWITCH
	FLOOD LIGHT W/ MOTION SENSOR		RETURN AIR		ONE POLE SWITCH
	FLUORESCENT		GARAGE DOOR OPENER		THREE-WAY SWITCH
			DOOR BELL		FOUR-WAY SWITCH
					DIMMER SWITCH
					ELECTRICAL PANEL
					EXTERIOR WATER FAUCET

GENERAL NOTES

- PROVIDE CRAWL SPACE ACCESS OPENING MIN. 24"x36"
- MAINTAIN MIN 18" SPACE BETWEEN TOP OF PIERS AND CRAWL SPACE GRADE. ADJUST FOR MECHANICAL DUCT CLEARANCES AS REQUIRED
- PROVIDE VAPOR BARRIER IN CRAWL SPACE
- MIN 8"x16" FOUNDATION VENTS. QUANTITY AS REQUIRED TO MEET MIN FREE AIR AREA AS CALCULATED
- ANCHOR BOLTS @ 6'-0" OC AND 1'-0" FROM EACH CORNER OF BUILDING EMBEDDED MIN 7" INTO MASONRY CELL GROUTED SOLID
- ALL SILL PLATES ON SLAB CONSTRUCTION SHALL BE PRESSURE TREATED MIN 2X4
- ALL MUD SILLS SHALL BE PRESSURE TREATED LUMBER
- PROVIDE THRU-WALL FLASHING @ ALL EXTERIOR WALLS @ TOP OF FOUNDATION WALL, AND MINIMUM 8" ABOVE GRADE
- PROVIDE THRU WALL FLASHING AT ALL DOOR AND WINDOW HEADS IN BRICK VENEER, EXTENDED MIN 8" BEYOND EACH END OF OPENING. FULL HEAD WEEPS MIN 32". MIN TWO WEEPS PER OPENING
- PROVIDE STEEL LINTELS @ ALL DOOR AND WINDOW HEADS IN BRICK VENEER
- TYPICAL CEILING HEIGHT 8'-0" AFF (UNO)
- TYPICAL WINDOW HEAD HEIGHT 6'-8" AFF (UNO)
- FULL HEAD WEEP JOINTS AT ALL THRU-WALL FLASHING, MIN 32" OC
- 1'-9" OVERHANGE FROM FACE OF STUD FRAMING WITH BRICK VENEER (FOR 1'-4" EXPOSED OVERHANG))
- 1'-4" OVERHANGE FROM STUD FRAMING @ LOCATIONS WITH HORIZONTAL SIDING
- OVERHANGE ON COVERED PORCHES MATCH OVERHANGE @ EXTERIOR WALL
- TYPICAL 5" FROM EXTERIOR FACE OF STUD TO EXTERIOR FACE OF BRICK VENEER
- ALL DIMENSIONS PROVIDED ARE TO FACE OF FRAMING MEMBERS UNLESS NOTED OTHERWISE

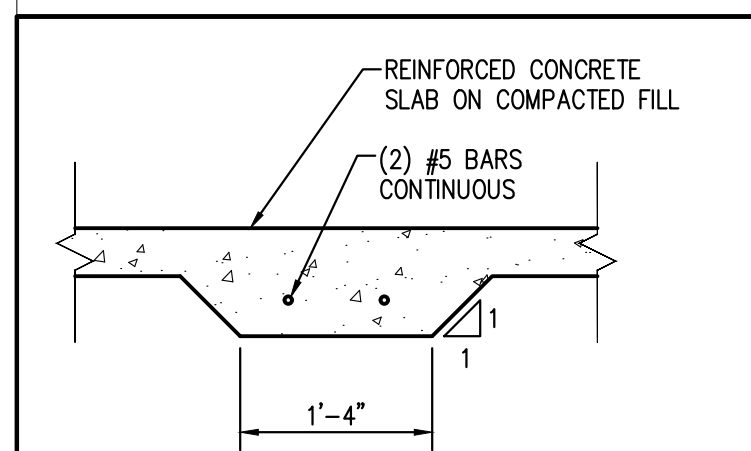

TYPICAL LUGGED FOOTING
3/4" = 1'-0"

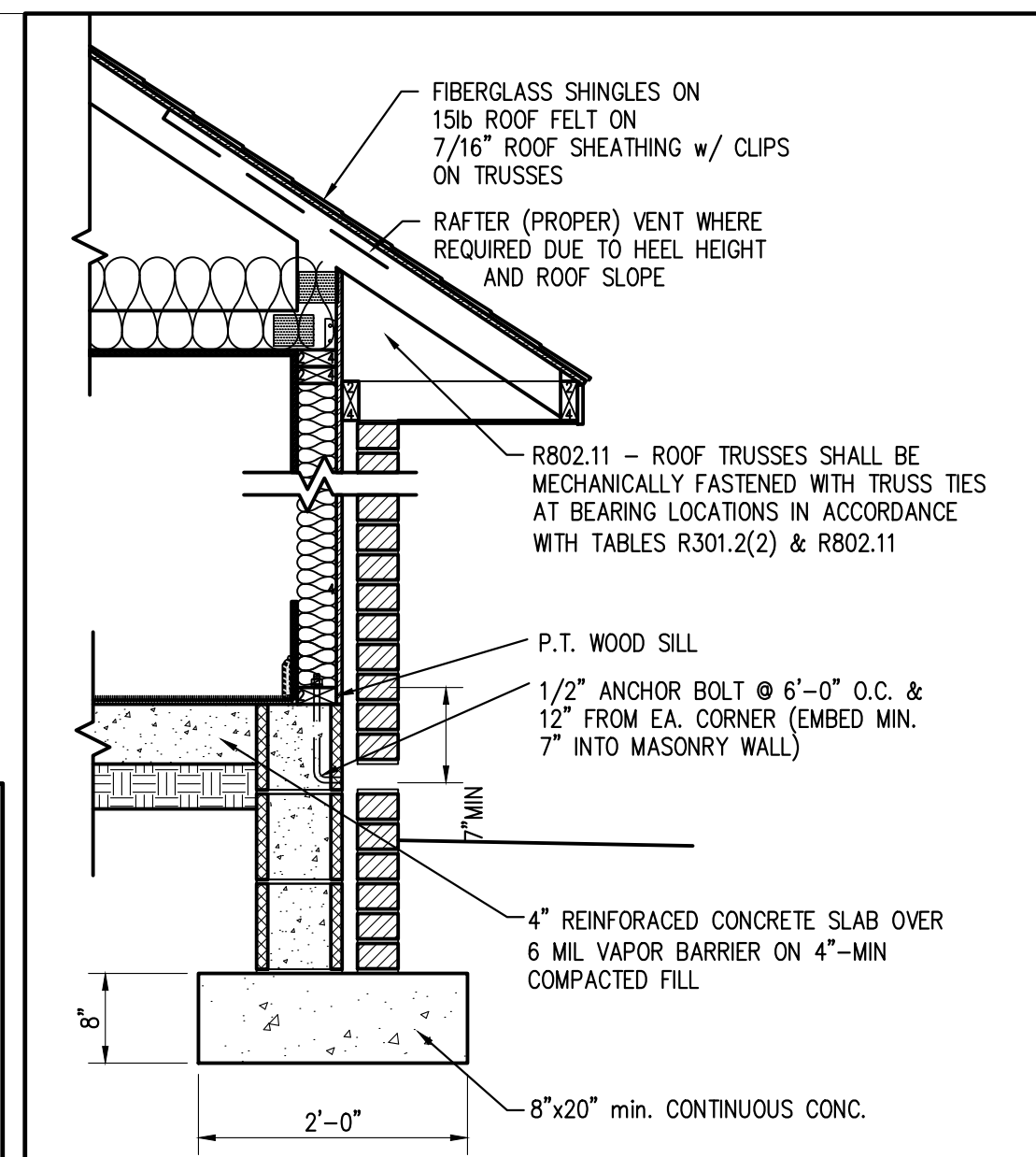

TYPICAL WALL SECTION W/ BRICK VENEER
3/4" = 1'-0" LESS THAN 110mph WIND ZONE

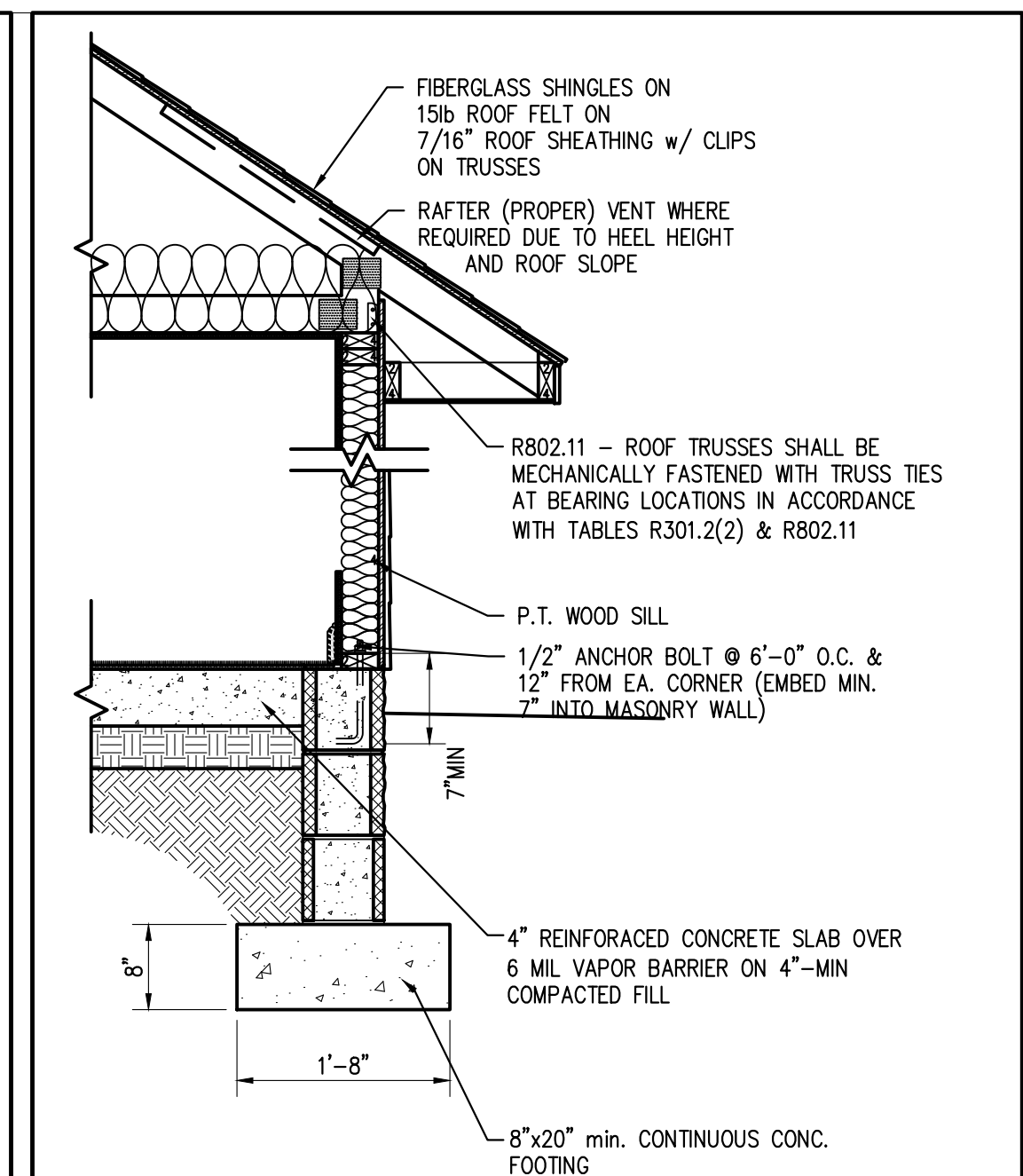

TYPICAL WALL SECTION
3/4" = 1'-0" LESS THAN 110mph WIND ZONE
FOUNDATION WALL HEIGHT VARIES AS GRADING REQUIRES

THE CONTRACTOR IS RESPONSIBLE FOR VERIFYING ALL DIMENSIONS AND BRING THE ATTENTION OF THE DESIGNER AS SOON AS IS PRACTICAL. THE CONTRACTOR IS REQUIRED TO MAKE ALL NECESSARY ADJUSTMENTS TO THE FOUNDATION CONSTRUCTION AS IS REQUIRE TO ADAPT TO THE SITE CONDITIONS.

The design and plans are the sole property of Ivercon Inc. These drawings are provided for the construction of a single house, for the exclusive use of this client, on the lot, designated herein. The documents may not be copied in any way without written consent.

PLAN #: 19-2111

OUR HAMPTON DESIGN

Subdivision:
LOT #:

IVERCON, INC.

PO Box 64778
Fayetteville, NC 28306

1/2"x12" ANCHOR BOLTS @ 6'-0"
O.C., 1'-0" FROM ENDS AT CORNERS,
1'-0" FROM ENDS AT ALL DOOR
JAMBS, AND 1'-0" FROM ENDS AT
ALL SPLICES IN WALL PLATES

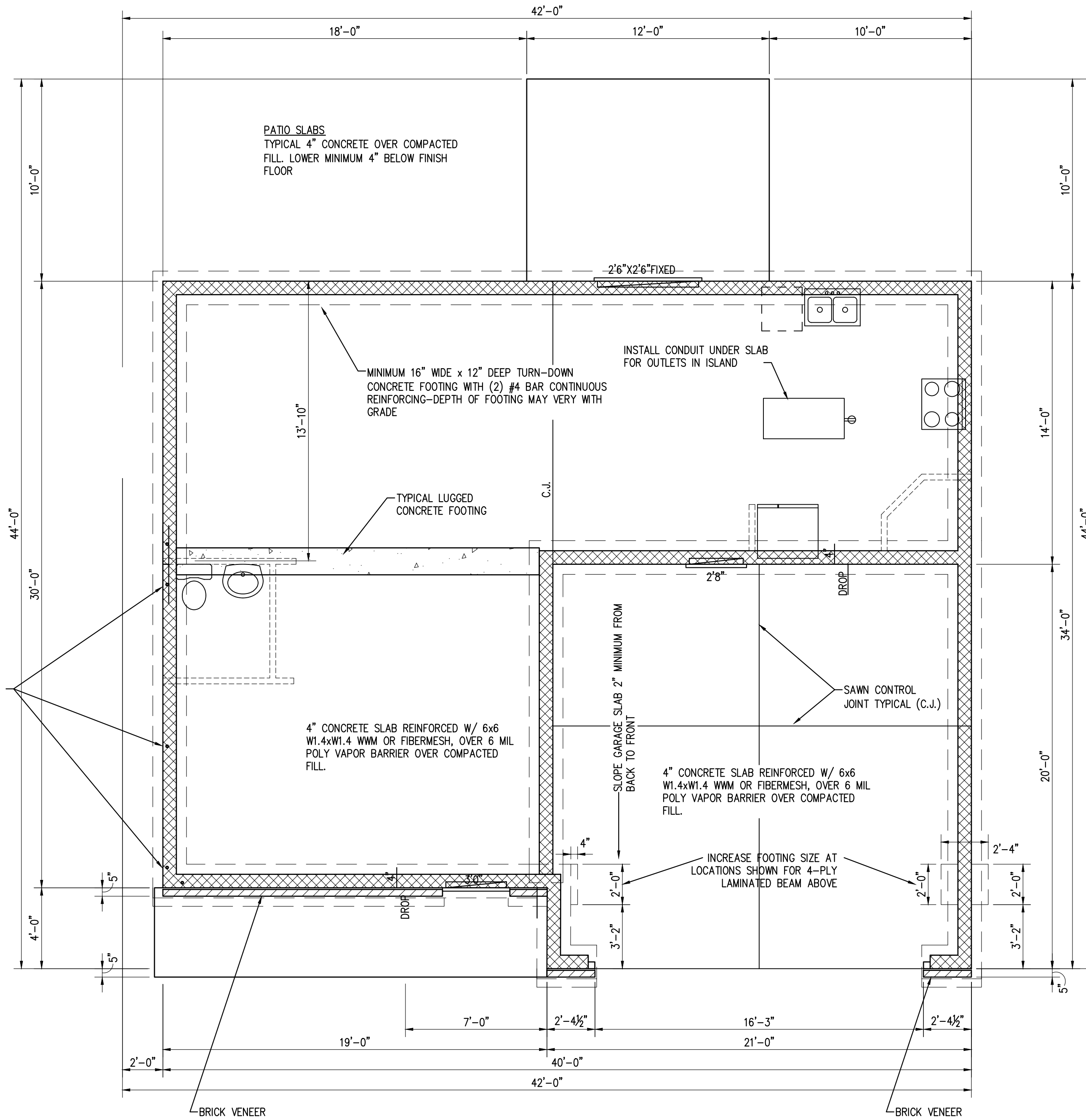

FOUNDATION PLAN
1/4" = 1'-0"

PORCH SLABS
TYPICAL 4" CONCRETE MONOLITHIC SLAB
OVER COMPACTED FILL. LOWER MINIMUM 4"
BELOW FINISH FLOOR

The design and plans are the sole property of Ivercon Inc. These drawings are provided for the construction of a single house, for the exclusive use of this client, on the lot, designated herein. The documents may not be copied in any way without written consent.

OUR HAMPTON DESIGN
LOT #:
Subdivision:

IVERCON, INC.
PO Box 64778
Fayetteville, NC 28306