ADDRESS : 1523 RED HILL CHURCH RD
 CONTRACTOR : CHOO'S MOBILE HOME TRANSIT
 OWNER : LUCAS RIVER SHAWN
 PARCEL : 02-1507- - -0245- - -
 APPL NUMBER: 18-50043334 CP MANUFACTURED HOME RA 30 CRITERIA
 DIRECTIONS : T/S: 02/16/2018 03:50 PM DJOHNSON --
 421 S TOWARDS DUNN THEN LEFT ONTO RED
 HILL CHURCH RD. GO APPROX 2 MILES AND
 PROPERTY IS ON THE LEFT. PASSED GRACE
 CHAPEL CHURCH.

STRUCTURE: 000 000 24X48 3 BR DWMH NO DECKS/PORCHES

FLOOD ZONE : FLOOD ZONE X
 # BATHS : 2 # BEDROOMS : 3.00
 MOBILE HOME YEAR : 2007.00 PROPOSED USE : DWMH
 SEPTIC - EXISTING? : NEW

PERMIT: CPDW 00 CP MOBILE HOME DOUBLEWIDE

TYP/SQ	REQUESTED COMPLETED	INSP RESULT	DESCRIPTION RESULTS/COMMENTS
H824 01	6/27/18	AC	ENVIR. OPERATIONS PERMIT TIME: 17:00 VRU #: 003145968
	6/27/18	AP	T/S: 06/28/2018 11:14 AM KHINSON ----- T/S: 06/28/2018 11:14 AM KHINSON -----
T501 01	7/05/18	KS	R*MOBILE HOME FOUND./ M. WALL TIME: 17:00 VRU #: 003147436
	7/05/18	DA	T/S: 07/03/2018 08:28 AM BPETRICH ----- T/S: 07/05/2018 03:25 PM KSLATTUM ----- Chasis not bonded together. 2. Duct shall have four inches of clearance. 3. Electrical crossover shall be tucked into the belly and protected. 4. Leak at 2 to 4 inch sweep. (left rear of house). 5. Longitudinal ties needed?
T501 02	<u>7/10/18</u>	<u>TT</u>	R*MOBILE HOME FOUND./ M. WALL TIME: 17:00 VRU #: 003149424
	<u>7-10-</u>	<u>AP</u>	T/S: 07/09/2018 10:26 AM JBROCK -----

----- COMMENTS AND NOTES -----

Minute Man **Anchors, inc.**

Installation Instructions for LLBS Longitudinal and Lateral Bracing System Wind Zones I-II & III ground and concrete applications

Special State requirements

Alabama - Maximum Pier Height 32". HUD Code Homes Only.

Florida - See Florida zone II & III Instructions.

Michigan - Foundation depth must be 42" below grade as per Chapter 1805.2.1 2000 Michigan Building Code.

Missouri - Anchors, stabilizer devices and frame ties with an allowable working load equal to or exceeding 3150 lbs. and are capable of withstanding a 50% overload (4725 lbs total) are required within 2' of the 4 corners on all single wide homes.

North Carolina - Requires that the bottom of footings be placed 4" under the soil, or at the frost line.

Minute Man Anchors LLBS System must be installed in complete accordance with Minute Man Anchors Installation instructions and the Home Manufacturer's Instructions.

Minute Man Anchors LLBS System is evaluated, tested and approved by a Professional Engineer.

Minute Man Anchors LLBS System must be allowed by the authority having jurisdiction.

Thank you for using Minute Man Products, Inc. If you have any questions, please call us at: (828) 692-0256

*Johnson Doublewide
Red Hill Church Rd
18-5-43334*

Minute Man anchors[®], Inc.

LIMITED WARRANTY

Minute Man Anchors, Inc. warrants its product is free from defects in materials and Workmanship at the time of installation when properly installed in accordance with the Installation instructions. THE FOREGOING WARRANTY IS IN LIEU OF ANY OTHER WARRANTY, WHETHER EXPRESS OR IMPLIED, WRITTEN OR ORAL, INCLUDING ANY WARRANTY OF MERCHANTABILITY OR FITNESS FOR A PARTICULAR PURPOSE. ANY LIABILITY IS EXPRESSLY LIMITED TO AN AMOUNT EQUAL TO THE PURCHASE PRICE PAID, AND ALL CLAIMS FOR SPECIAL, INCIDENTAL AND CONSEQUENTIAL DAMAGES ARE HEREBY EXCLUDED. Minute Man does not assume any other liability or obligation in connection with the sale or use of this product.

If the product is defective at the time of delivery or installation and you give prompt notice to Minute Man no later than thirty (30) days of attempted installation of the defect, Minute Man, at its option, will replace the product at no cost or refund the full amount of the purchase price, provided the defective product is returned to Minute Man with proof of purchase at the address set forth below. **PRODUCT REPLACEMENT OR REFUND IS YOUR SOLE AND EXCLUSIVE REMEDY.**

This warranty extends only to the distributor and original installer of the product and does not cover a defect resulting from abuse, misuse, neglect, repairs, any use not in conformity with the printed instructions or installation by unauthorized personnel.

This warranty gives you specific legal rights, and you may also have other legal rights which vary from state to state. Some states do not allow limitations on implied warranties or special, incidental or consequential damages, so the foregoing limitations may not apply to you.

If you have a claim under this warranty, please contact our CUSTOMER SERVICE department (have model and type numbers available):

CUSTOMER SERVICE

Toll Free in the U.S. 1-800-438-7277
1-828-692-0256

OR WRITE TO:

Minute Man-Customer Service
305 West King Street
East Flat Rock, NC 28726

To our knowledge, the information provided in and by the independent, profession engineers' reports and certifications and obtained from other independent sources contained in the installation instructions and product manuals is accurate. However, Minute Man Anchors, Inc. cannot assume any liability whatsoever for the accuracy or completeness thereof. Final determination of the suitability of any information or material for the use contemplated is the sole responsibility of the user. Specifications are subject to change without notice. The load ratings established in the report are not valid in any application where the use of the product would overload any structural member of the home of foundation.

Wind Zone I
Patent# 6622439

Minute Man **Anchors, inc.**

**Installation Instructions for Model LLBS Longitudinal and
Lateral Bracing System Zones I**

The LLBS is not designed to be used as a supporting pier.

Note: Your set must be designed by a Registered Professional Engineer if the following conditions occur:

Location is within 1,500 feet of Coast	Roof eaves exceeds 16"
Pier Height exceeds 48"	Main beam spacing exceeds 99.5"
Sidewall height exceeds 96"	

- 1 Refer to the Home Manufacturer Installation Instructions for pier locations. Refer to the home manufacturer Installation Instructions for required footing size and pier spacing. Note: SD3 pad is 2.8 sq. Ft. Vertical Sidewall and Marriage wall anchors may be required by the home manufacturer when using the MMA LLBS systems. See Manufacturer's instructions. * M a x Pier Height 48"
- 2 Refer to the Systems Placement Plans for the location of Longitudinal Lateral Bracing System. **(See Attached)**
- 3 Remove turf to expose firm soil at each SD3 pad location. Install SD3 pad to manufacturer, state, local codes, and frost line guidelines as it may apply. For extremely hard or rocky soil, mark four (4) slots and pre-drill soil with a 3/4 x 12" masonry drill.
- 4 Attach tube clip to SD3 pier pads (see Detail Assembly Drawing) center pad under beam, level pad. Angle Drive Pins may be driven vertically through four (4) slots in SD3 pier pad now or after home is totally set. Angle drive pins may be driven up to ten degrees (10) off of vertical. If you choose to drive pins after home is set, do not cover slots in pier pad.
- 5 Level home on concrete blocks or steel pier by Minute Man.
- 6 Install Longitudinal and Lateral Bracing in accordance with System Placement Plan and Detail Assembly Drawing. **(1 longitudinal brace tube per system in Wind Zone I only).**
- 7 3,150 lb. Working load anchors with stabilizers and frame ties are required on 4 corners of all single wide homes.
- 8 Special Instructions: Alabama; LLBS Systems approved for maximum 32" pier height.

Thank you for using Minute Man Products, Inc. If you have any questions, please call Toll Free at (800) 438-7277.

305 West King St. East Flat Rock, North Carolina 28726

ZONE I LONGITUDINAL AND LATERAL BRACING SYSTEMS PLACEMENT

Vertical sidewall and marriage wall anchors may be required by the home manufacturer when using the MMA LLBS system, see the manufacturer's instructions. 3,150 lb. Working load anchors with stabilizers and frame ties are required on 4 corners of all single wide homes. Systems must be as equally spaced as possible. (Triple wides and tag units require 2 additional systems. Place additional systems at the corner ends of the exposed side of the home.)

HOME DIMENSIONS REPRESENT BOX SIZE- FOR HOMES OVER 80' CALL MMA

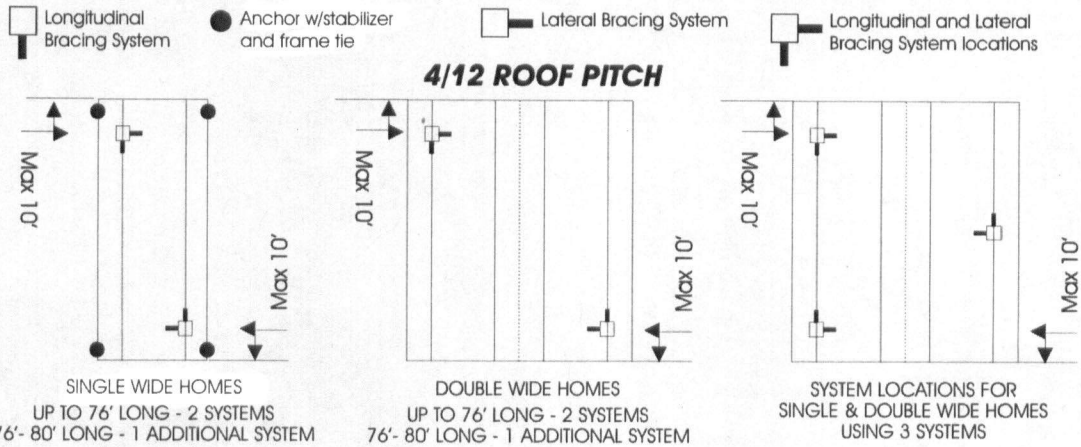

LLBS System Requirements for roof pitches over 20° with 8' Sidewalls

Home's Length ft.	Roof Pitch/Degree of Slope				
	5:12	6:12	7:12	8:12	9:12
	22.62°	26.57°	30.26°	33.69°	36.87°
34'	2	2	2	2	2
36'	2	2	2	2	2
38'	2	2	2	2	2
40'	2	2	2	2	2
42'	2	2	2	2	3
44'	2	2	2	3	3
46'	2	2	2	3	3
48'	2	2	3	3	3
50'	2	3	3	3	3
52'	2	3	3	3	3
54'	3	3	3	3	3
56'	3	3	3	3	3

Home's Length ft.	Roof Pitch/Degree of Slope				
	5:12	6:12	7:12	8:12	9:12
	22.62°	26.57°	30.26°	33.69°	36.87°
58'	3	3	3	3	3
60'	3	3	3	3	3
62'	3	3	3	3	3
64'	3	3	3	3	4
66'	3	3	3	4	4
68'	3	3	3	4	4
70'	3	3	4	4	4
72'	3	3	4	4	4
74'	3	3	4	4	4
76'	3	4	4	4	4
78'	3	4	4	4	4
80'	3	4	4	4	4

Call Minute Man Products for system requirements on homes with 9' Sidewalls

LATERAL BRACE FLEX TUBES FOR CONCRETE

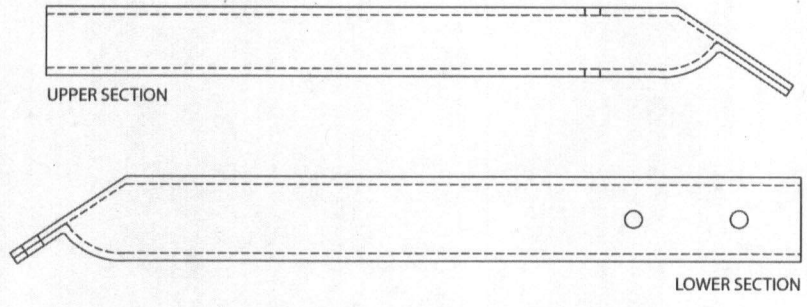

LONGITUDINAL BRACE FLEX TUBES FOR CONCRETE

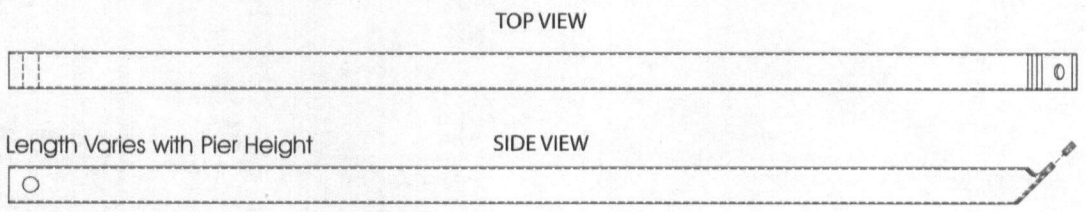

LATERAL BRACE DETAIL FOR SD3 PIER PAD

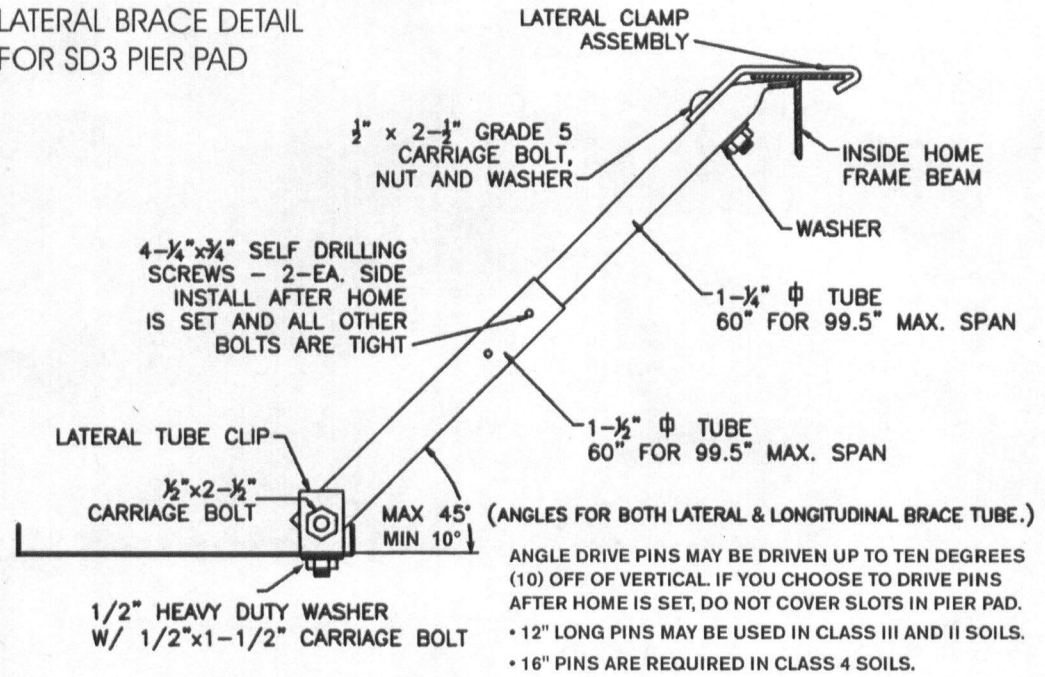

LONGITUDINAL BRACE DETAIL FOR SD3 PIER PAD

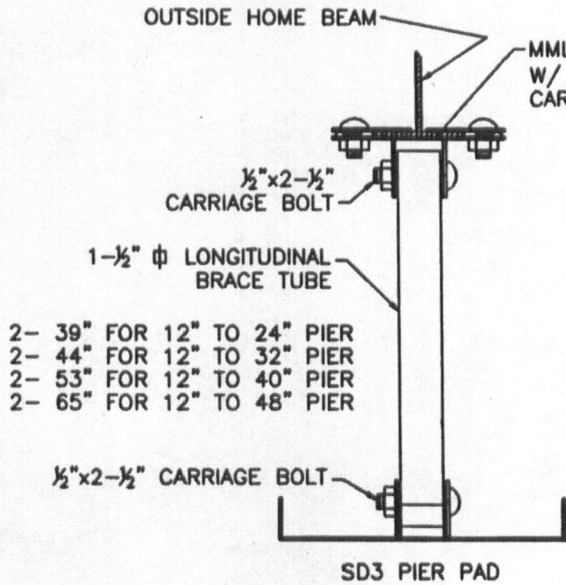

NOTES

MAXIMUM PIER HEIGHT 48"

MAX. SIDEWALL HEIGHT 96"

MAX. BEAM SPACING 99.5"

MAX ROOF EAVES 16"

NOTE: 1/2" BOLTS ARE GRADE 5

WHEN USING LONGITUDINAL BRACES, 2ND PIER IN FROM THE END OF THE HOME MAY BE USED TO MAKE ROOM FOR BRACE TUBES.

LONGITUDINAL & LATERAL BRACING SYSTEM
DETAIL ASSEMBLY DRAWING

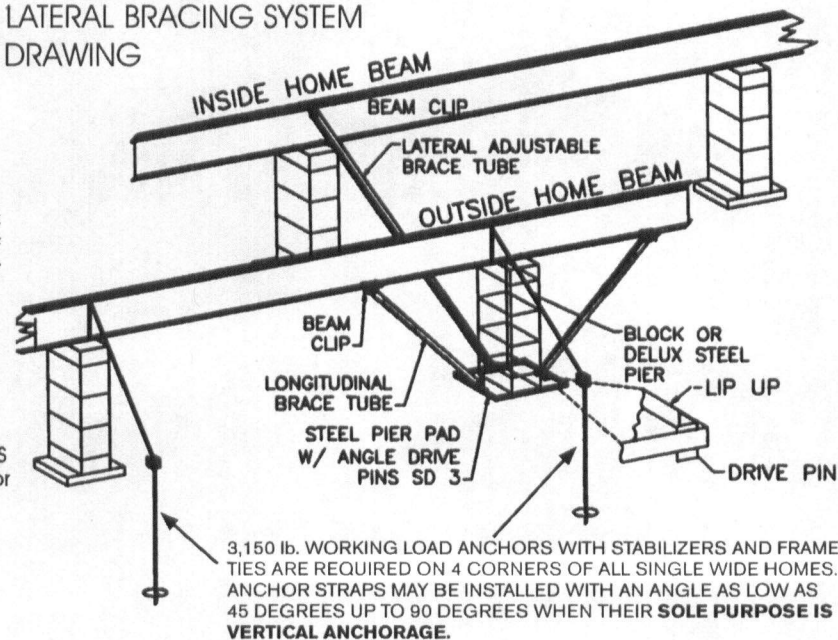
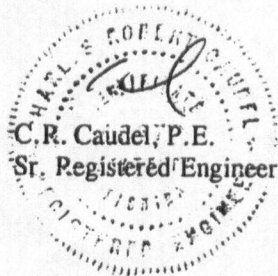

The Minute Man Anchors LLBS Bracing System was tested for Wind Zones I, II, & III
 Tested 10/10/01
 Rev. 3/6/02
 Rev. 7/14/04
 Rev. 2/1/10
 Rev. 1/1/15

3,150 lb. WORKING LOAD ANCHORS WITH STABILIZERS AND FRAME TIES ARE REQUIRED ON 4 CORNERS OF ALL SINGLE WIDE HOMES. ANCHOR STRAPS MAY BE INSTALLED WITH AN ANGLE AS LOW AS 45 DEGREES UP TO 90 DEGREES WHEN THEIR SOLE PURPOSE IS VERTICAL ANCHORAGE.

