

# HALOWEN & ASSOCIATES, P.C.

SOIL & ENVIRONMENTAL SCIENTISTS

P. O. Box 400, 266 Old Coats Road

Lillington, NC 27546

Phone (910) 893-8743 / Fax (910) 893-3594

E-mail: halowen@intrstar.net

28 December, 2001

Mr. Oliver Tolksdors  
Harnett County Environmental Health  
P.O. Box 9  
Lillington, NC 27546

Reference: Septic System Design for a Four Bedroom Single Family Dwelling  
Lots 6M-8M, Captain's Landing  
Wayne and Lynn Lasalle Property

Dear Mr. Tolksdors,

A site investigation and septic system design was conducted and prepared for the above referenced property located on the northwest side of Burgandy Street in Captain's Landing Subdivision, Buckhorn Township, Harnett County, North Carolina. The purpose of the investigation was to demonstrate the ability of this combination of lots to support a subsurface sewage waste disposal system and 100 % repair area for a four-bedroom home. Public water supplies will be utilized for this lot. A foundation drain will not be possible with the present location of the home in relation to the proposed septic systems.

The soils present on Lot 6M are rated as provisionally suitable soils for fill systems due to a shallow depth to excessive soil wetness. Although most of Lot 7M & 8M have been disturbed, an area remains behind the home that also exhibits similar soils but were not utilized in the septic system design. This area may be useful for partial additional repair area if needed in the future. The upper 18-24 inches of the provisionally suitable soils on Lot 6M were observed to be friable clay loams. Wetness conditions were typically observed between 15-20 inches below ground surface thus the utilization of fill systems. The lowest application rate that is in this textural group is required for this type of system; therefore the system design has been based on a 0.3 gpd/sqft application rate. The proposed initial system utilizes eight 70-foot conventional drainlines in this bed of fill material. The proposed fill system for the repair utilizes six 70-foot innovative drainlines. These drainlines will need to be located approximately three inches above the natural ground surface. These proposed drainlines are flagged on site with various colored pin flags for your review. These pin flags were laid out on contour and maintain at least a 22-foot setback off the side property line where the drainlines run perpendicular to it and 23.5-foot off the rear property line where the drainlines run parallel. Once a permit is issued, the area required for the initial system will need to be cleared carefully so that fill material for the trenches can be applied to the site.

Fifteen inches of fill material is required for the base of this system and should be a sandy or loamy sand texture up to the top of the nitrification lines. This material should be nearly free of any fibrous organics, debris or building rubble. This fifteen inches of sandy fill should be added in five inch layers with the first layer to be tilled to a depth of 6 inches in order to incorporate the soils and obtain a transitional layer between the original and new material. The remaining fill can then be added up to 15 inches above the original surface. The drainlines can be installed at grade at this point. The cover material (15-21 inch depth above original surface) can then be added and should be a finer textured soil such as a sandy loam or sandy clay loam to enable the growth of a vegetative cover. This bed of fill material should extend 5 feet beyond the edges of the entire drainfield and then taper to the original surface at a rise to run ratio of 1:4 feet. Immediately after the cover material is added and the site shaped to shed surface water; a grass cover needs to be established.

Attached is the septic system layout and supporting information for this lot. We trust that this report provides all the information that you require at this time. If you have any questions or need additional information, please contact us at your convenience.

Sincerely,



Laura J. Fortner  
Soil Scientist in Training III



Hal Owen  
Licensed Soil Scientist



# HALOWEN & ASSOCIATES, P.C.

## SOIL & ENVIRONMENTAL SCIENTISTS

P.O. Box 400, 266 Old Coats Road  
Lillington, NC 27546  
Phone (910) 893-8743 / Fax (910) 893-3594  
E-mail: halowen@intrstar.net

28 December, 2001

Mr. Doug Maclean  
C/o Horton Homes  
7324 Capital Blvd.  
Raleigh, NC 27616

Reference: Septic System Design for Single Family Dwelling  
Lots 6M-8M, Captain's Landing  
Wayne and Lynn Lasalle Property

Dear Mr. Horton,

A septic system design has been prepared for the above referenced property to demonstrate Lots 6M-8M's ability to adequately support a four-bedroom home. A fill system utilizing conventional drainlines was able to be demonstrated for the initial septic system and a fill system utilizing innovative drainlines was demonstrated on the lot for the repair system. Attached is the septic system design and supporting information that has been submitted on your behalf to Mr. Oliver Tolksdors of the Harnett County Health Department for the review and permitting process. This report represents our professional opinion but does not guarantee or represent permit approval for any lot by the local Health Department.

The septic system has been demonstrated with various colored pin flags that are located on the lot. Once you have re-applied for a permit from the Health Department and they have visited the site and issued a permit, the portion of lot 6M that is being utilized for the initial septic system will have to be cleared for installation of the drainfield. We would like to take this time to reiterate the importance that little to no ground disturbing activity should be conducted. **The topsoil should not be scraped, or moved or re-shaped in any way.** Large trees should be removed with as little impact as possible. It is recommended that the large trees are cut off at ground level and the stumps left in the ground. You may wish to use a stump grinder to further remove some of the stump material down to the original ground surface or just below. Holes or depressions left by tree removal or other clearing activities should be filled in to original grade with topsoil type materials either brought in from off site or gathered from onsite in areas not designated for the septic system or the repair area. **If there is any doubt about where materials can be gathered from on site, you should request that we provide guidance or use an off site source for the needed materials.** In addition to these aforementioned recommendations, it is important that no activity or installation is carried out during wet conditions and the use of heavy equipment on the lot should be kept at a bare minimum.

We appreciate the opportunity to provide this service and hope to be allowed to assist you again in the future. If you have any questions or need additional information, please contact us at your convenience.

Sincerely,



Laura J. Fortner  
Soil Scientist in Training III



Hal Owen  
Licensed Soil Scientist

Lee C. Smith, Captain, Licensing  
 On-Site Wastewater Design Specifications

Prepared By: L.J.F.  
 J. Owen & Associates, Inc.  
 Soil & Environmental Scientists  
 P.O. Box 400, 266 Old Coats Rd.  
 Lenoir, NC 27546 0400  
 Phone: (910) 893-8743

House Footprint: 26' x 72' (No Foundation Drain)  
 Bedrooms: 4

Initial System: 8 x 70' conventional fill system  
 on contour at: 3 inches above natural surface  
 LTAR: 0.3 gpd/sqft  
 Repair System: 6 x 70' innovative fill system  
 on contour at: 2 inches above natural surface  
 LTAR: 0.4 gpd/sqft (w/innovative)

LEGEND

★	EIP	▭	Septic Tank
⌋	Step-down	■	Pump Tank
⊕	Proposed Well	○	D-Box
⊗	Existing Well	⊠	Pressure Manifold

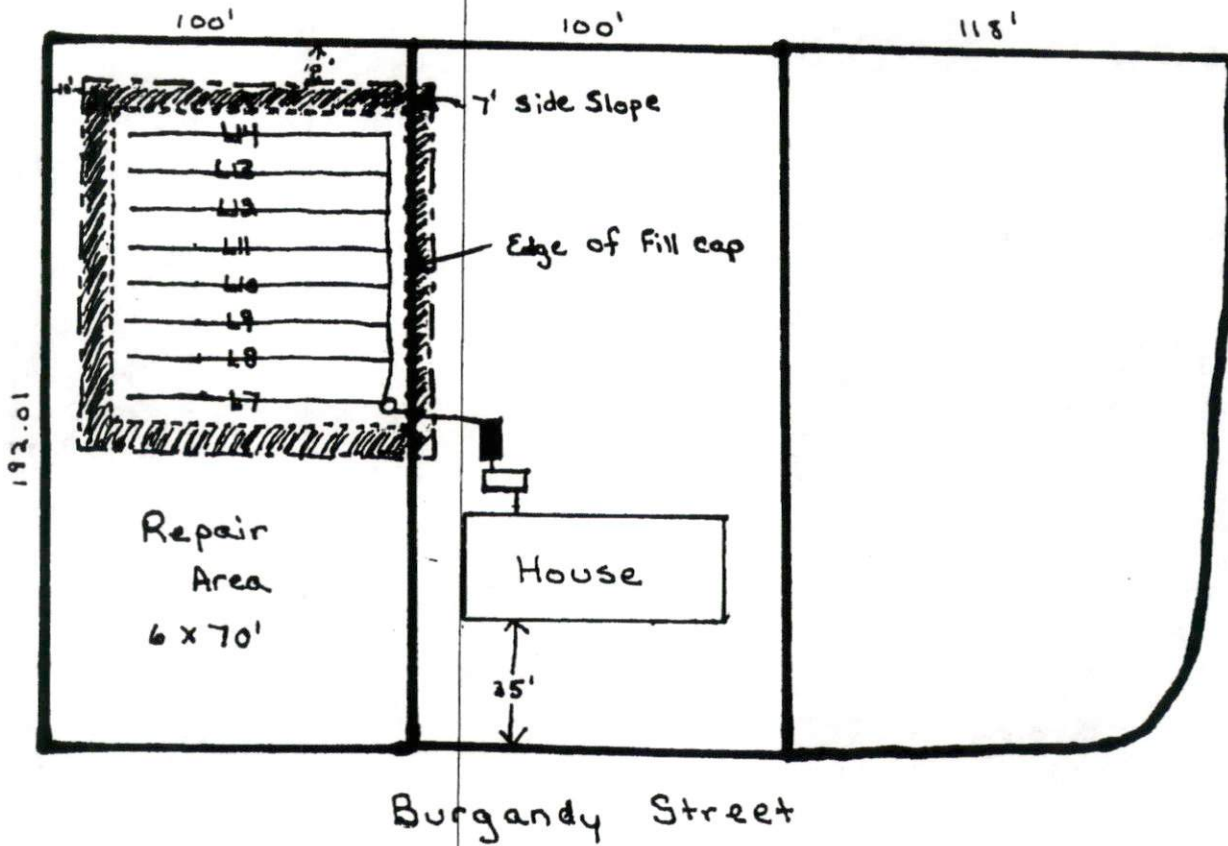

1" = 50'

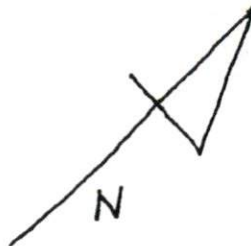



Lot 6M-8M, Captain's Lanung Subdivision

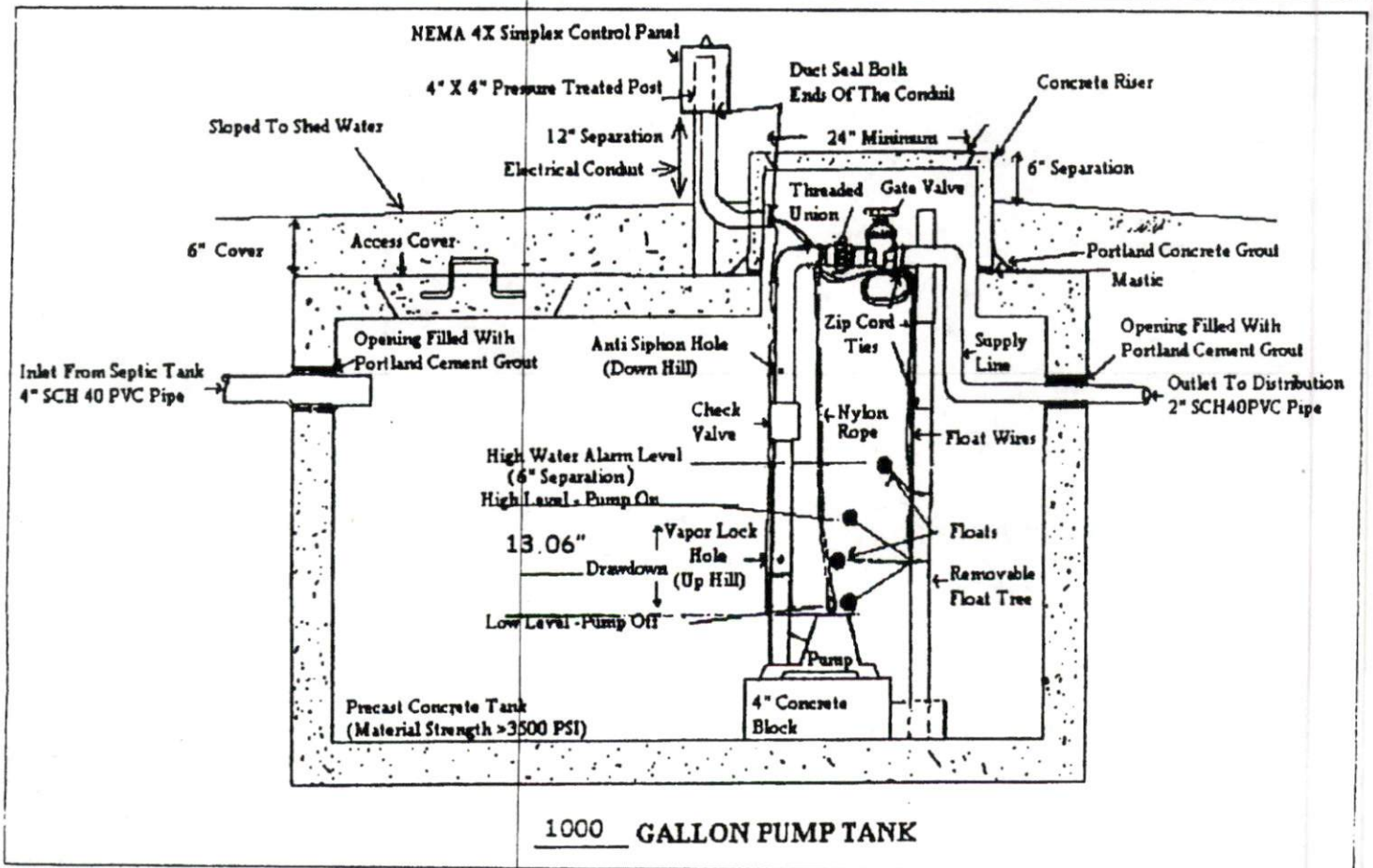
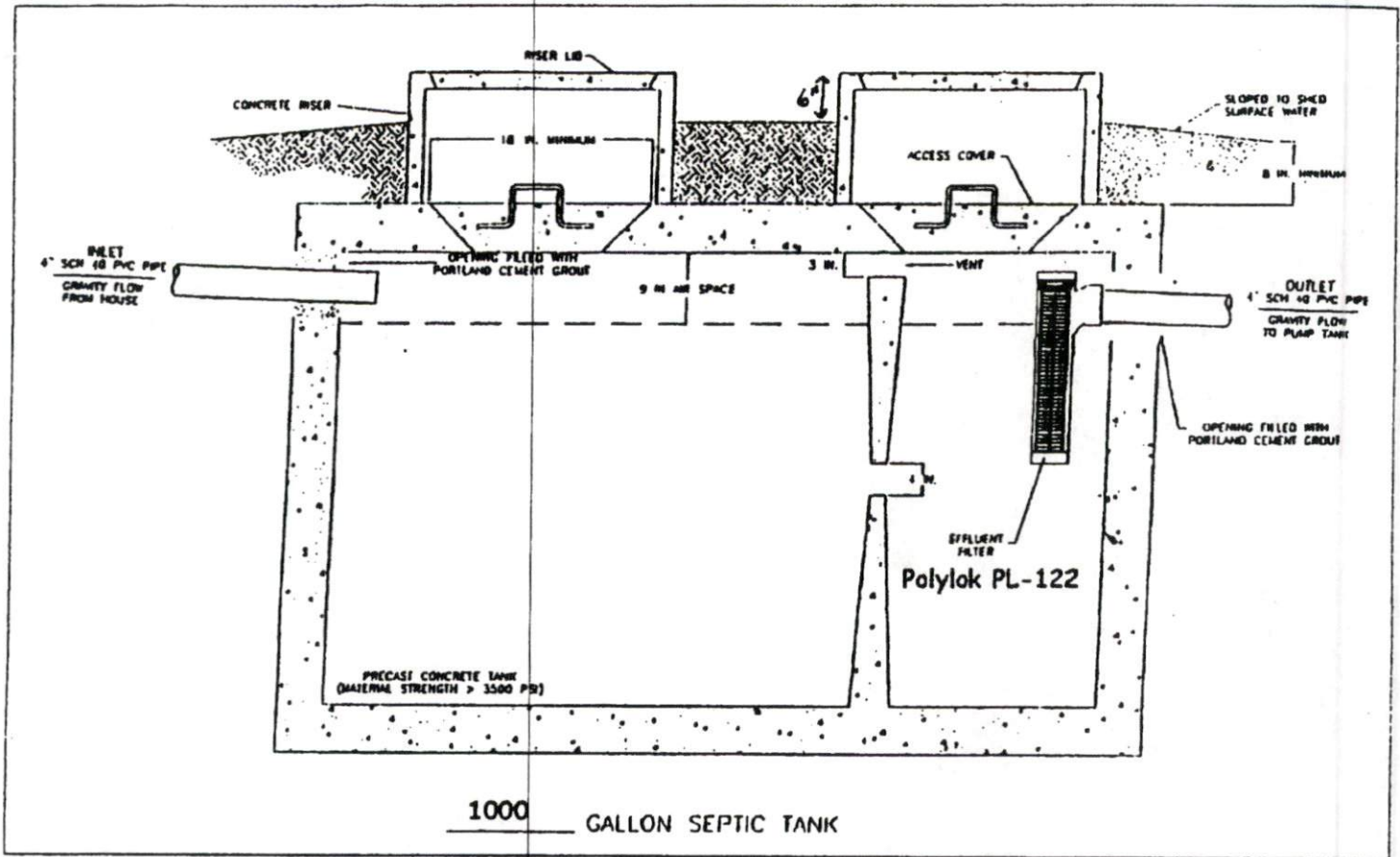

# BARNES

# EHV

## SUBMERSIBLE EFFLUENT PUMPS 3/4" Spherical Solids Handling

SECTION	B
PAGE	1
DATE	1/01
REPLACES	12/99

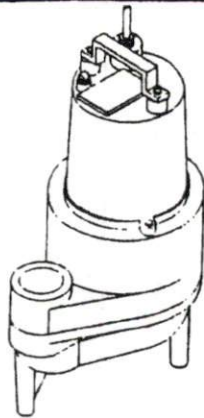

Series: EHV .5 HP 3450RPM



CSA 108 - File No. LR16567  
UL 778

NRTLIC

### Description:

PUMP IS DESIGNED FOR HANDLING SEWAGE EFFLUENT IN TYPICAL SEPTIC TANK/EFFLUENT APPLICATIONS.

DISCHARGE: 2", (51mm) N.P.T. Female, Vertical.  
 LIQUID TEMPERATURE: 77°F (25°C) Continuous.  
 MOTOR HOUSING: Cast Iron  
 PUMP BODY: Cast Iron  
 IMPELLER: *Design:* Multi-Vane Vortex  
                   *Material:* Cast Iron.  
 SHAFT: 420 Stainless Steel  
 O-RINGS: Buna-N  
 HARDWARE: 300 Series Stainless Steel  
 PAINT: Air Dry Enamel  
 CABLE ENTRY: 20 ft. (6M) Cord with Plug and Pressure Grommet for Sealing and Strain Relief.  
 SEAL: *Design:* Single Mechanical, Oil-Filled Reservoir.  
           *Material:* Rotating Faces - Ceramic  
                       Stationary Faces - Carbon  
                       Elastomer - Buna-N  
                       Hardware - 300 Series Stainless  
                       3450 RPM  
 SPEED:  
 UPPER BEARING: *Design:* Single Row, Ball  
 LOWER BEARING: *Design:* Single Row, Ball  
 MOTOR: *Design:* Oil-Filled.  
           *Insulation:* Class B.  
 SINGLE PHASE: Permanent Split Capacitor (PSC).  
                       Includes Overload Protection in Motor.  
 FLOAT: EHV412  
           EHV412A  
           EHV412VF  
           EHV412AT  
                       None  
                       Wide Angle, Mechanical, 20ft (6M) Cable,  
                       Pipe Mounted.  
                       Vertical Float, PVC, Snap Action.  
                       Wide Angle, Mechanical, 20ft (6M) Cable,  
                       Pump Mounted.

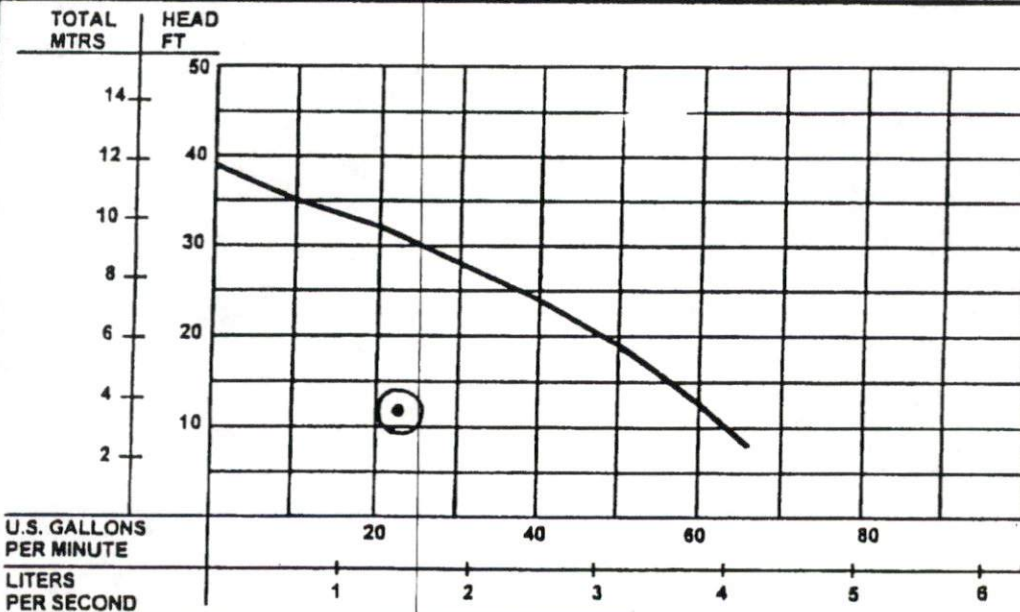

Testing is performed with water, specific gravity of 1.0 @ 68° F, other fluids may vary performance.

## CRANE

A Crane Co. Company

### PUMPS & SYSTEMS

Barnes Pumps, Inc.  
 Service Parts & Warranty Dept.  
 420 Third Street/P.O. Bx 603  
 Piqua, Ohio 45356-0603  
 Ph: (937) 615-3599  
 Fax: (937) 773-7157

Barnes Pumps, Inc.  
 Sales Office  
 1485 Lexington Ave.  
 Mansfield, Ohio 44907-2674  
 Ph (419) 774-1511  
 Fax (419) 774-1530

Barnes Pumps Canada, Inc.  
 83 West Drive  
 Bramalea, Ontario  
 Canada L6T 2J6  
 Ph. (905) 457-6223  
 Fax. (905) 457-2650





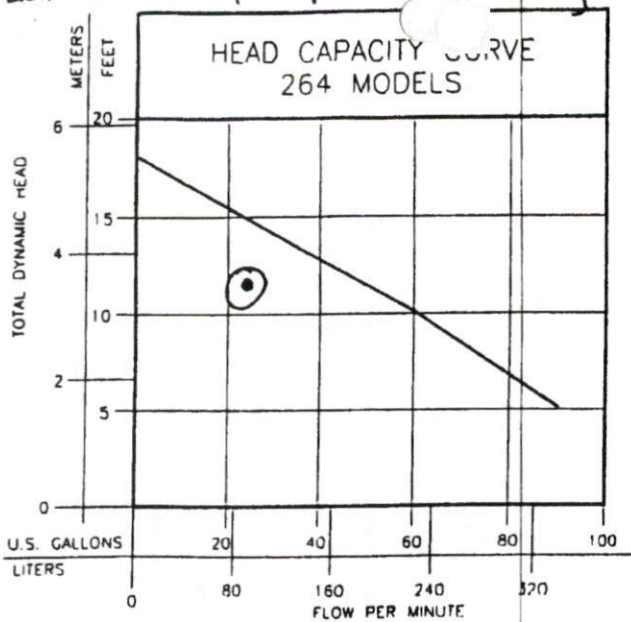

TOTAL DYNAMIC HEAD/CAPACITY PER MINUTE SEWAGE AND DEWATERING

264 MODELS			
Fl.	Meters	Gal.	Ltrs.
5	1.52	90	341
10	3.05	60	227
15	4.57	22.5	85
Lock Valve:			18 ft

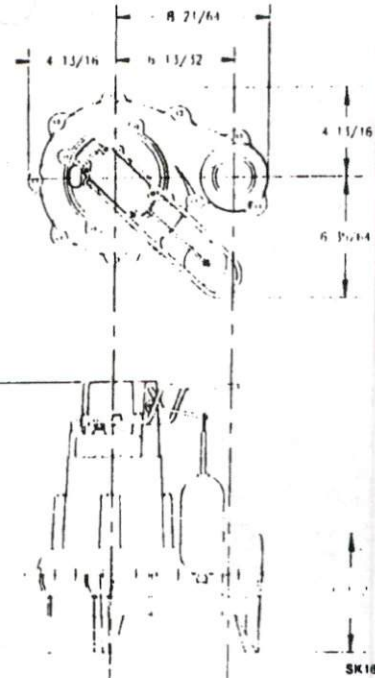

009931

SK1843

### CONSULT FACTORY FOR SPECIAL APPLICATIONS

- Electrical alternators for duplex systems available with variable level float switches.
- Minimum recommended basin size  
Simplex-18"x30"  
Duplex-30"x30"
- Standard Automatic - Weight 39 lbs. .4 H.P.
- High water alarms available.
- Mechanical alternators available for duplex systems.

**CAUTION** Maximum temperature of sewage or dewatering must be limited to 130° F. (54° C.) For over 130° F. (54° C.) special quotation required.

264 MODELS				CONTROL SELECTION		
Model	Volts	Ph	Mode	Amps	Simplex	Duplex
M264	115	1	Auto	9.4	1 or 1 & 7	—
N264	115	1	Non	9.4	2 or 2 & 6	3 or 4 & 5
D264	230	1	Auto	4.7	1 or 1 & 7	—
E264	230	1	Non	4.7	2 or 2 & 6	3 or 4 & 5

### SELECTION GUIDE

1. Integral float operated 2-pole mechanical switch, no external control required.
2. Single piggyback variable level float switch, or double piggyback variable level float switch. Refer to FM0477.
3. Mechanical alternator M-Pak 10-0072 or 10-0075.
4. See FM0712 for correct model of electrical alternator.
5. Control switch 10-0225 used as a control activator specify duplex (3) or (4) float system.

For information on additional Zoeller products refer to catalog on Piggyback Variable Level Float Switches, FM0477, Electrical Alternator, FM0488, Mechanical Alternator, FM0495, Sump/Sewage Basins, FM0487, and Single Phase Simplex Pump Control, FM1596, Alarm System, FM0732

**CAUTION**

All installation of controls, protection devices and wiring should be done by a qualified licensed electrician. All electrical and safety codes should be followed including the most recent National Electric Code (NEC) and the Occupational Safety and Health Act (OSHA).

### RESERVE POWERED DESIGN

For unusual conditions a reserve safety factor is engineered into the design of every Zoeller pump.



<http://www.zoeller.com>

**ZOELLER**  
PUMP CO.

MAIL TO: P.O. BOX 16347  
Louisville, KY 40256-0347  
SHIP TO: 3649 Cane Run Road  
Louisville, KY 40211-1961  
(502) 778-2731 • 1 (800) 928-PLUM  
FAX (502) 774-3624

Manufacturers of

"Quality Pumps Since 1939"

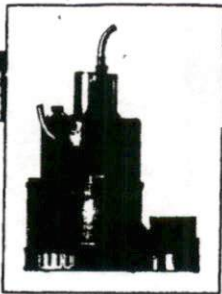

**Pump Characteristics**

Pump/Motor Unit	Submersible	
Manual Models	SW25M1	SW33M1
Automatic Models	SW25A1	SW33A1
Horsepower	1/4	1/3
Full Load Amps	8.0	10.0
Motor Type	Shaded Pole (4 pole)	
R.P.M.	1550	
Phase Ø	1	
Voltage	115	
Hertz	60	
Operation	Intermittent	
Temperature	120 °F Ambient	
NEMA Design	A	
Insulation	Class A	
Discharge Size	1-1/2" NPT	
Solids Handling	1/2"	
Unit Weight	30 lbs.	
Power Cord	18/3, SJTW, 10' std. (20' optional)	

**Performance Data**

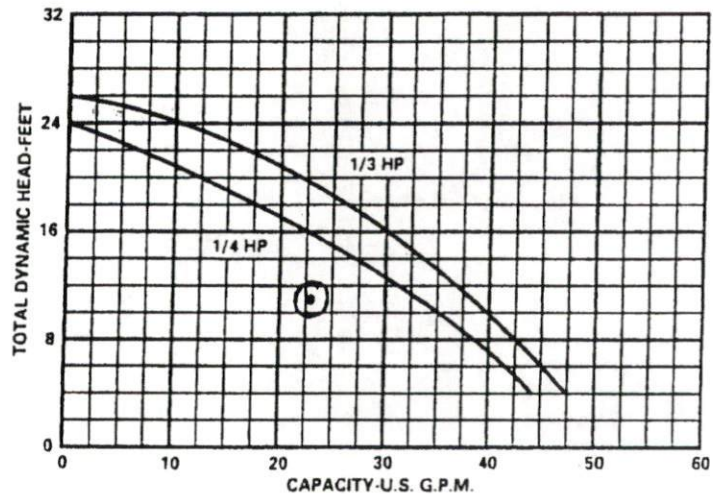

Total Head (feet)	4	6	8	10	12	14	16	18	20	22	24
1/4 HP	44	41	36	33	29	26	23	18	12	6	0
1/3 HP	47	45	43	40	37	34	30	26	22	16	10

**Dimensional Data**

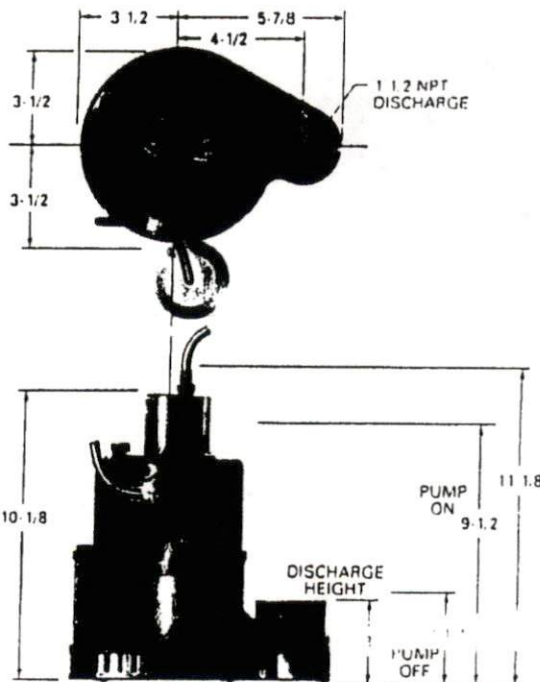

1. All dimensions in inches
2. Component dimensions may vary ± 1/8 inch
3. Not for construction purpose unless certified
4. Dimensions and weights are approximate
5. On/Off level adjustable
6. We reserve the right to make revisions to our products and their specifications without notice

**Materials of Construction**

Handle	Steel
Lubricating Oil	Dielectric Oil
Motor Housing	Cast Iron
Pump Casing	Cast Iron
Shaft	Steel
Mechanical Shaft Seal	Seal Faces: Carbon/Ceramic Seal Body: Anodized Steel Spring: Stainless Steel Bellows: Buna-N
Impeller	Thermoplastic
Upper Bearing	Bronze Sleeve Bearing
Lower Bearing	Single Row Ball Bearing
Strainer/Base	Plastic
Fasteners	Stainless Steel

**AURORA/HYDROMATIC Pumps, Inc.**  
 1840 Baney Road, Ashland, Ohio 44805  
 (419) 289-3042

# MODEL 112 Control Panel

## Single phase, simplex motor contactor control.

The Model 112 control panel provides a reliable means of controlling one 120, 208, or 240 VAC single-phase pump in pump chambers, sump pump basins, irrigation systems and lift stations. Two control switches activate a magnetic motor contactor to turn the pump on and off. If an alarm condition occurs, an additional alarm switch activates the audio/visual alarm system.

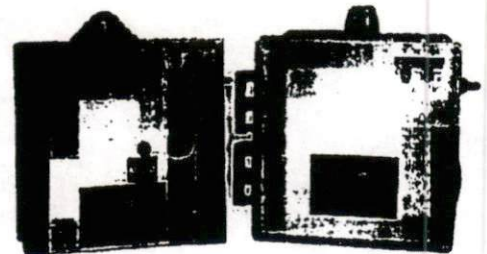

Model Shown  
1121W914X

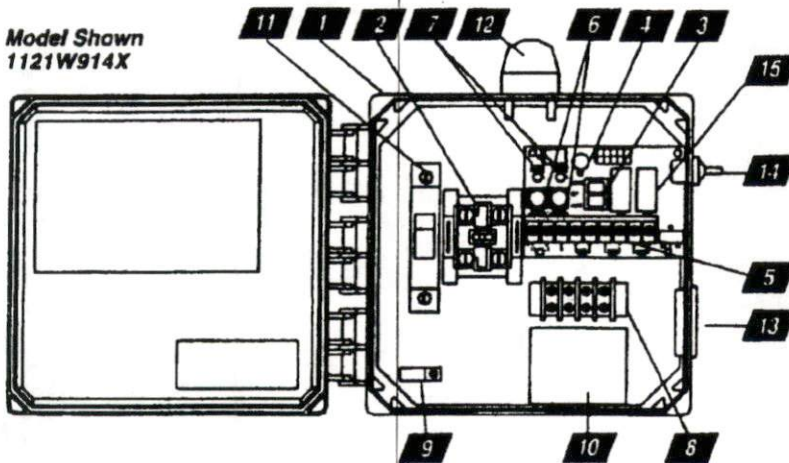

1. Enclosure measures 8 x 8 x 4 inches (20.32 X 20.32 X 10.16 cm). Choice of NEMA 1 (steel for indoor use), or NEMA 4X (ultraviolet stabilized thermoplastic with removable flanges for outdoor or indoor use).  
\* Options selected may increase enclosure size and change component layout.
2. Magnetic Motor Contactor controls pump by switching hot electrical lines.
3. HOA Switch for manual pump control (mounted on circuit board).
4. Green Pump Run Indicator Light (mounted on circuit board).
5. Float Switch Terminal Block (mounted on circuit board).
6. Alarm and Control Fuses (mounted on circuit board).
7. Alarm and Control Power Indicators (mounted on circuit board).
8. Pump Input Power and Pump Connection Terminal Block
9. Ground Lug
10. Terminal Block Installation Label
11. Circuit Breaker (optional) provides pump disconnect and branch circuit protection.

### STANDARD ALARM PACKAGE (other options available)

12. Red Alarm Beacon provides 360° visual check of alarm condition.  
Note: NEMA 1 style utilizes a door mounted indicator in lieu of a beacon.
13. Alarm Horn provides audio warning of alarm condition (83 to 85 decibel rating).  
Note: NEMA 1 style utilizes an internally mounted buzzer (83 to 85 decibel) in lieu of horn.
14. Exterior Horn Test/Normal/Silence Switch allows alarm horn to be silenced and testing of horn and light to ensure proper operation of alarm system.
15. Horn Silence Relay automatically resets alarm after alarm condition has been resolved (mounted on circuit board).

## FEATURES

- Entire control system (panel and switches) is UL Listed to meet and/or exceed industry safety standards
- Dual safety certification for the United States and Canada
- Standard package includes three 20' Sensor Float® control switches
- Complete with step-by-step installation instructions
- Three-year limited warranty



**SJE rhombus**  
SJE ELECTRO SYSTEMS, INC.

PO Box 1708, Detroit Lakes, MN 56502  
1-888-DIAL-SJE • 1-218-847-1317  
1-218-847-4617 Fax  
email: sje@sjerhombus.com  
[www.sjerhombus.com](http://www.sjerhombus.com)

# Lot 6M-8M, Captain's Lane Subdivision

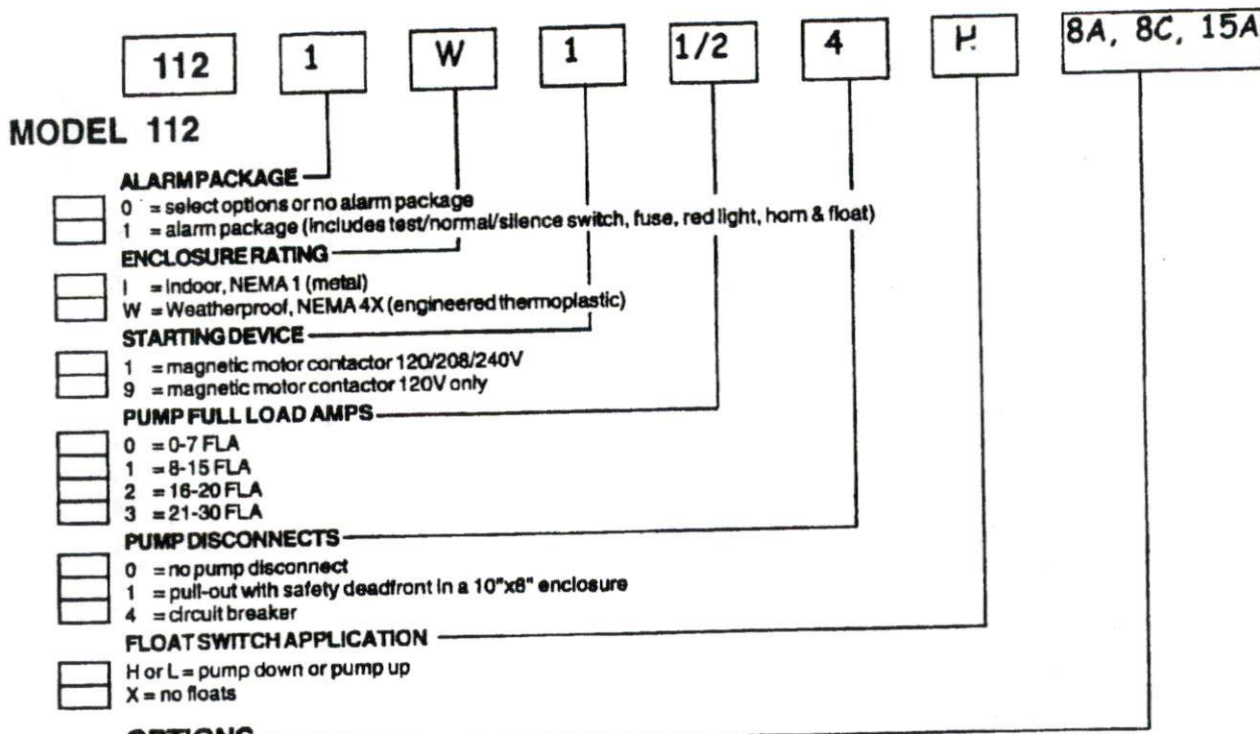

**OPTIONS** *Listed below*

★ Options selected may increase enclosure size and change component layout.

*If additional features are required, call the factory for a quote on either a Pro-Line or Engineered Custom control panel system.*

CODE	DESCRIPTION	CODE	DESCRIPTION
<input type="checkbox"/> 1A	Red beacon only / no audio <i>must select 1E if floats included</i>	<input type="checkbox"/> 11C	NEMA 1 alarm panel <i>must select option 6A</i>
<input type="checkbox"/> 1C	Horn only / no visual <i>must select 1E if floats included</i>	<input type="checkbox"/> 11D	NEMA 4X alarm panel <i>must select option 8A</i>
<input type="checkbox"/> 1E	Alarm float	<input type="checkbox"/> 15A	Control / alarm circuit breaker <i>Does not include the circuit board as in standard.</i>
<input type="checkbox"/> 3A	Alarm flasher	<input type="checkbox"/> 16A	10' cord in lieu of 20'
<input type="checkbox"/> ★ 4A	Low level cutout <i>select option 4D if floats included</i>	<input type="checkbox"/> 16B	15' cord in lieu of 20'
<input type="checkbox"/> ★ 4B	Red low-level indicator & alarm <i>must select 4A also</i>	<input type="checkbox"/> 16C	30' cord in lieu of 20'
<input type="checkbox"/> 4D	Low-level float	<input type="checkbox"/> 16D	40' cord in lieu of 20'
<input type="checkbox"/> 6A	Auxiliary alarm contact, form C type	<input type="checkbox"/> 17A	SJE SignalMaster® / mounting strap ●
<input type="checkbox"/> ★ 8A	Elapsed time meter	<input type="checkbox"/> 17B	SJE SignalMaster® / externally weighted ●
<input type="checkbox"/> ★ 8C	Event (cycle) counter	<input type="checkbox"/> 17C	Sensor Float® / internally weighted ▲
<input type="checkbox"/> 10E	Lockable latch - NEMA 4X	<input type="checkbox"/> 17D	Sensor Float® / externally weighted ▲
<input type="checkbox"/> 10E	Lockable latch - NEMA 1	<input type="checkbox"/> 17E	Sensor Float® Mini / pipe clamp ▲
<input type="checkbox"/> ★ 10F	Lightning arrester	<input type="checkbox"/> 17F	Sensor Float® Mini / externally weighted ▲
<input type="checkbox"/> ★ 10K	Anti-condensation heater	<input type="checkbox"/> 19X	Door mounted pump run indicator
		<input type="checkbox"/> 21A	Pumpmaster® in lieu of on/off switches ●
		<input type="checkbox"/> 21B	PumpMaster® Plus in lieu of on/off switches ●
		<input type="checkbox"/> 21C	Super Single® in lieu of on/off switches ▲
		<input type="checkbox"/> 21D	Double Float™ in lieu of on/off switches ▲

● Mechanically-activated    ▲ Mercury-activated

**SAMPLE**

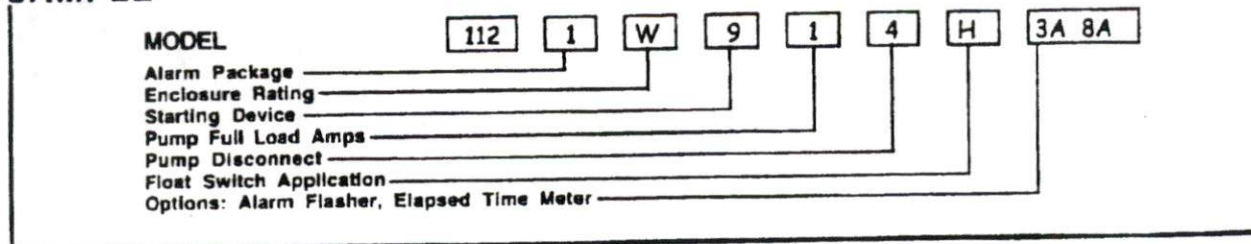

OWNER NAME: BEST VALUE/NEW GENERATION APPLICATION #: 19197

\*This application to be filled out only when applying for a new septic system.\*

**County Health Department Application for Improvement Permit and/or Authorization to Construct**

IF THE INFORMATION IN THIS APPLICATION IS FALSIFIED, CHANGED, OR THE SITE IS ALTERED, THEN THE IMPROVEMENT PERMIT OR AUTHORIZATION TO CONSTRUCT SHALL BECOME INVALID. The permit is valid for either 60 months or without expiration depending upon documentation submitted. (complete site plan = 60 months; complete plat = without expiration)

**DEVELOPMENT INFORMATION**

- New single family residence
- Expansion of existing system
- Repair to malfunctioning sewage disposal system
- Non-residential type of structure

**WATER SUPPLY**

- New well
- Existing well
- Community well
- Public water
- Spring

Are there any existing wells, springs, or existing waterlines on this property?  
{ } yes {  } no { } unknown

**SEPTIC**

If applying for authorization to construct please indicate desired system type(s): can be ranked in order of preference, must choose one.

- { } Accepted      {  } Innovative
- { } Alternative      { } Other \_\_\_\_\_
- { } Conventional      { } Any

The applicant shall notify the local health department upon submittal of this application if any of the following apply to the property in question. If the answer is "yes", applicant must attach supporting documentation.

- { } YES {  } NO Does the site contain any Jurisdictional Wetlands?
  - { } YES {  } NO Does the site contain any existing Wastewater Systems?
  - { } YES {  } NO Is any wastewater going to be generated on the site other than domestic sewage?
  - { } YES {  } NO Is the site subject to approval by any other Public Agency?
  - { } YES {  } NO Are there any easements or Right of Ways on this property?
  - { } YES {  } NO Does the site contain any existing water, cable, phone or underground electric lines?
- If yes please call No Cuts at 800-632-4949 to locate the lines. This is a free service.

I Have Read This Application And Certify That The Information Provided Herein Is True, Complete And Correct. Authorized County And State Officials Are Granted Right Of Entry To Conduct Necessary Inspections To Determine Compliance With Applicable Laws And Rules. I Understand That I Am Solely Responsible For The Proper Identification And Labeling Of All Property Lines And Corners And Making The Site Accessible So That A Complete Site Evaluation Can Be Performed.

*[Signature]*  
PROPERTY OWNERS OR OWNERS LEGAL REPRESENTATIVE SIGNATURE (REQUIRED)

1-15-2008  
DATE

~~0-18 SWK SWL WFL NST NP~~

~~18 24" SWK E WFL STP~~

# PRESSURE MANIFOLD DESIGN

Hal Owen Associates, Inc.  
 Soil Environmental Scientists  
 PO Box 400, Lillington, NC 27546  
 Phone (910) 893-8743 Fax 893-3594

Applicant: Wayne & Lynn Lasalle, c/o Mr. Doug Maclean of Horton Home Phone #: (919) 850-9800  
 Mailing Address: 7324 Capital Blvd., Raleigh, NC 27616  
 PIN: \_\_\_\_\_ D#: \_\_\_\_\_ S/D: Captain's Landing Lot#: 6M-8M  
 Site Address: 1463 Natchez Trace

# BDR: 4 Daily Flow: 480 Square Ft: 1200.00 Linear Feet: 560  
 LTAR: 0.3 gpd/sqft LTAR w/ innov: \_\_\_\_\_ gpd/sqft  
 Septic Tank (gal): 1000 Pump Tank (gal): 1000

Length of Trenches (ft): 8 x 70' Bottom Dimensions of Fill System (ft): 94 x 90 Top Dimensions of Fill System (ft): 80 x 76  
3" above  
 Trench Bottom Depth (in): nat. surface Depth of Sand (in): 15 Cover Depth (in): 6  
 Length of Side Slope (ft): 7 Total Depth of Fill (in): 21

Supply Line Length (ft): 25 Diameter: 2" sch 40 pvc

Pump Tank Elevation: \_\_\_\_\_ Pump Elevation (ft): -5

Simplex Control Panel, **SJE Rhombus 112** or equal, with elapsed time meter and cycle counter is required.  
 Floats to be determined by type of pump tank used. A septic filter, **Polylok PL-122** or equal is required.  
 Possible pumps include:

Hydromatic: SW25/33 Zoeller: 264 series Barnes: EHV .5HP

Friction Head (ft): 0.95 Design Head (ft): 2  
 Elevation Head (ft): 8 Total Head (ft): 10.95  
 Dose Volume (gal): 274.26 with Pipe Volume at % 75  
 Pump to Deliver: 21.92 gpm @ 11.00 ft head  
 Dose PRT(min): 12.51 Daily PRT(min): 21.90  
 Drawdown: 274.26 gallons divided by 21 gal/ inch = 13.06 inches

## Tap Chart

Initial/Repair	Line #	Color	Drainline Length Used (ft)	Measured Field Line Length(ft)
Repair	1	R	70	75
Repair	2	W	70	72
Repair	3	Y	70	73
Repair	4	B	70	75
Repair	5	R	70	70
Repair	6	W	70	71
Repair	7	Y	70	72
Initial	8	B	70	70
Initial	9	R	70	73
Initial	10	W	70	76
Initial	11	Y	70	77
Initial	12	B	70	75
Initial	13	R	70	76
Initial	14	W	70	78
Total Drainline:			980	1033

# Lot 6M-8M, Captain's Landing Subdivision

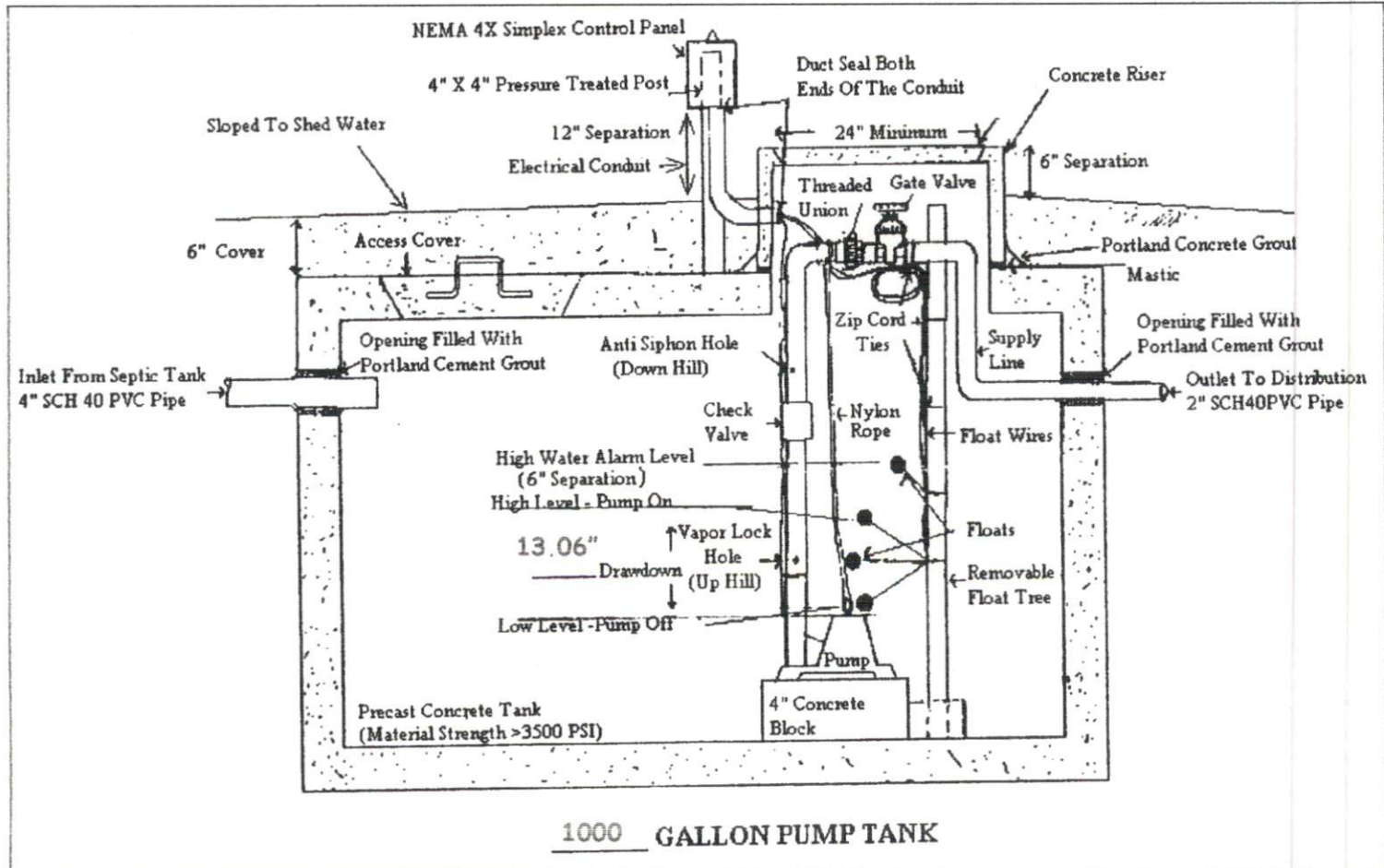
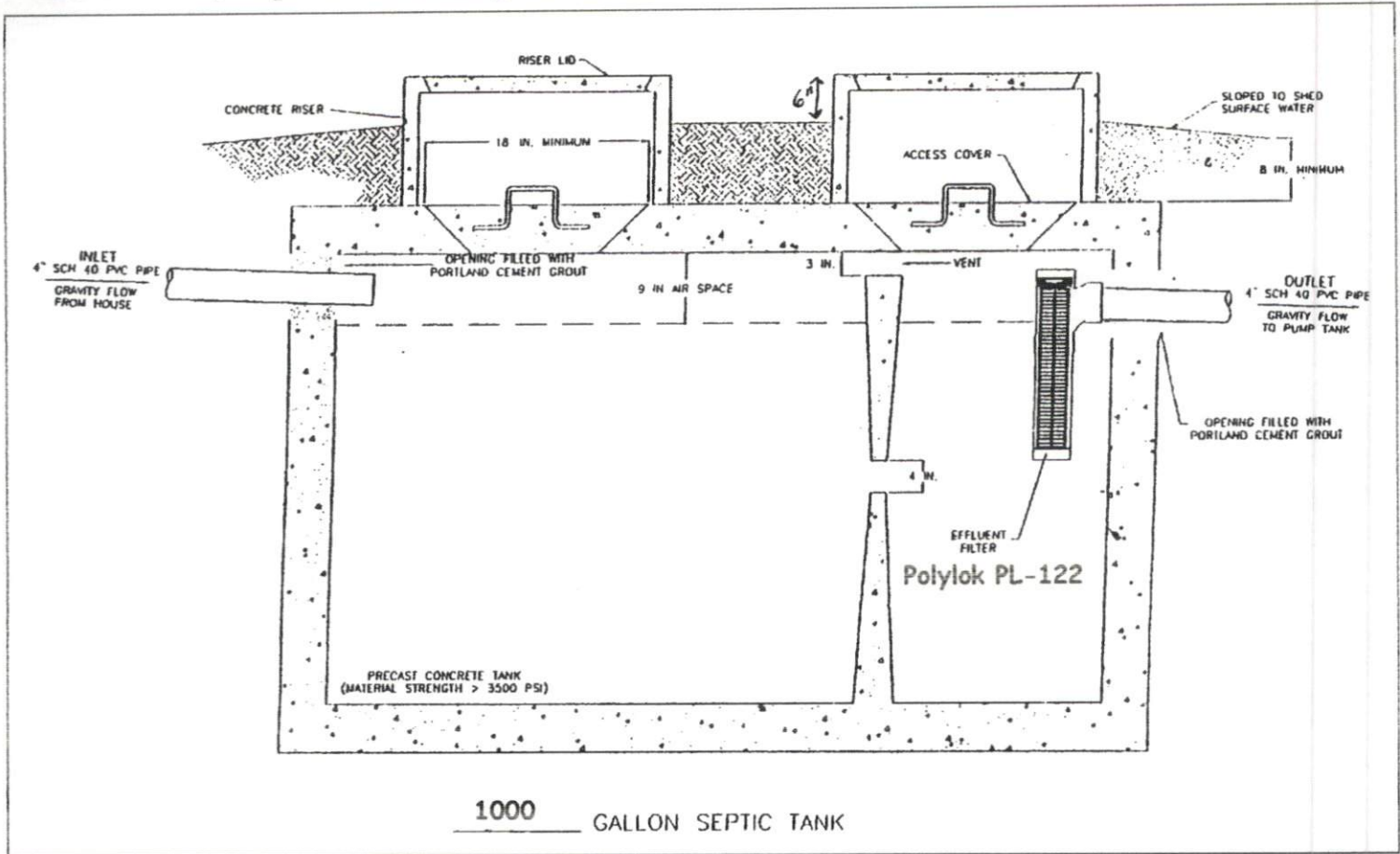



Lot 6M-8M, Captain! - landing

# BARNES EHV

**SUBMERSIBLE EFFLUENT PUMPS**  
**3/4" Spherical Solids Handling**

SECTION	B
PAGE	1
DATE	1/01
REPLACES	12/99

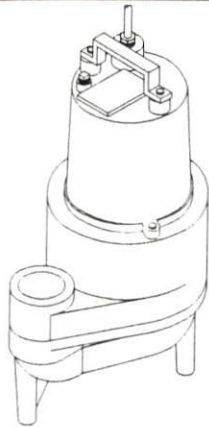

**Series: EHV .5 HP 3450RPM**



CSA 108 - File No. LR16567  
 UL 778

NRTLIC

**Description:**

PUMP IS DESIGNED FOR HANDLING SEWAGE EFFLUENT IN TYPICAL SEPTIC TANK/EFFLUENT APPLICATIONS.

**DISCHARGE:** 2", (51mm) N.P.T. Female, Vertical.  
**LIQUID TEMPERATURE:** 77°F (25°C) Continuous.  
**MOTOR HOUSING:** Cast Iron  
**PUMP BODY:** Cast Iron  
**IMPELLER:** *Design:* Multi-Vane Vortex  
*Material:* Cast Iron.  
**SHAFT:** 420 Stainless Steel  
**O-RINGS:** Buna-N  
**HARDWARE:** 300 Series Stainless Steel  
**PAINT:** Air Dry Enamel  
**CABLE ENTRY:** 20 ft. (6M) Cord with Plug and Pressure Grommet for Sealing and Strain Relief.  
**SEAL:** *Design:* Single Mechanical, Oil-Filled Reservoir.  
*Material:* Rotating Faces - Ceramic  
 Stationary Faces - Carbon  
 Elastomer - Buna-N  
 Hardware - 300 Series Stainless  
**SPEED:** 3450 RPM  
**UPPER BEARING:** *Design:* Single Row, Ball  
**LOWER BEARING:** *Design:* Single Row, Ball  
**MOTOR:** *Design:* Oil-Filled.  
*Insulation:* Class B.  
**SINGLE PHASE:** Permanent Split Capacitor (PSC).  
 Includes Overload Protection in Motor.  
**FLOAT:** EHV412 None  
 EHV412A Wide Angle, Mechanical, 20ft (6M) Cable, Pipe Mounted.  
 EHV412VF Vertical Float, PVC, Snap Action.  
 EHV412AT Wide Angle, Mechanical, 20ft (6M) Cable, Pump Mounted.

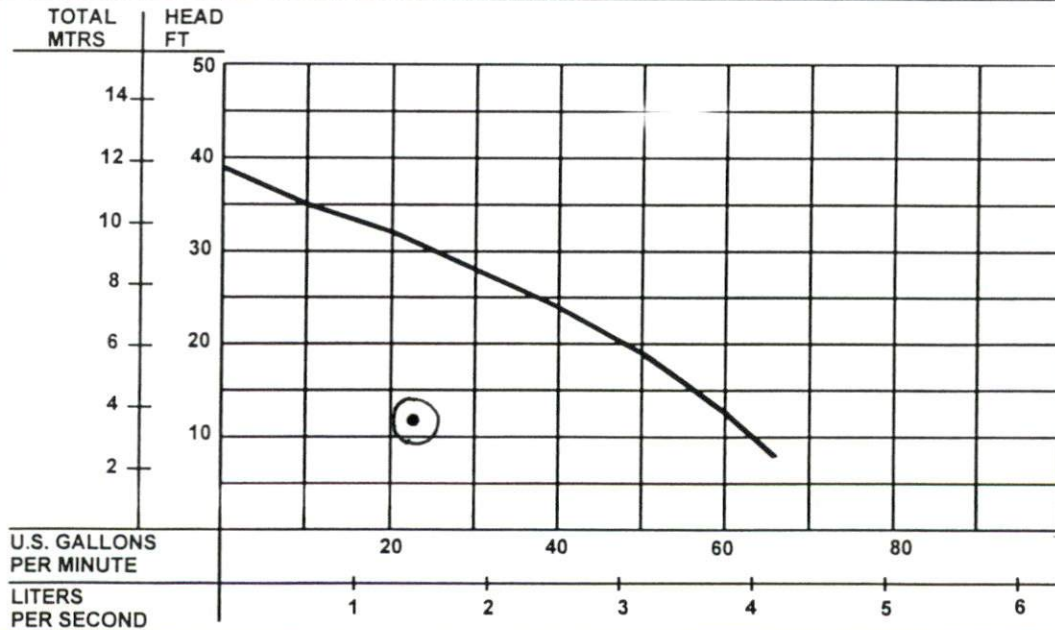

Testing is performed with water, specific gravity of 1.0 @ 68° F, other fluids may vary performance.



A Crane Co. Company

**PUMPS & SYSTEMS**

Barnes Pumps, Inc  
 Service Parts & Warranty Dept.  
 420 Third Street/P.O. Box 603  
 Piqua, Ohio 45356-0603  
 Ph: (937) 615-3599  
 Fax: (937) 773-7157

Barnes Pumps, Inc.  
 Sales Office  
 1485 Lexington Ave.  
 Mansfield, Ohio 44907-2674  
 Ph: (419) 774-1511  
 Fax: (419) 774-1530

Barnes Pumps Canada, Inc.  
 83 West Drive  
 Bramalea, Ontario  
 Canada L6T 2J6  
 Ph: (905) 457-6223  
 Fax: (905) 457-2650



SECTION	B
PAGE	2
DATE	7/01
REPLACES	1/01

Lot 6M-8M, Captain's Landing

**EHV412A**  
**EHV412 (Less Float)**  
**EHV412AT (Attached to Motor Housing)**

**EHV412VF**

inches  
(mm)

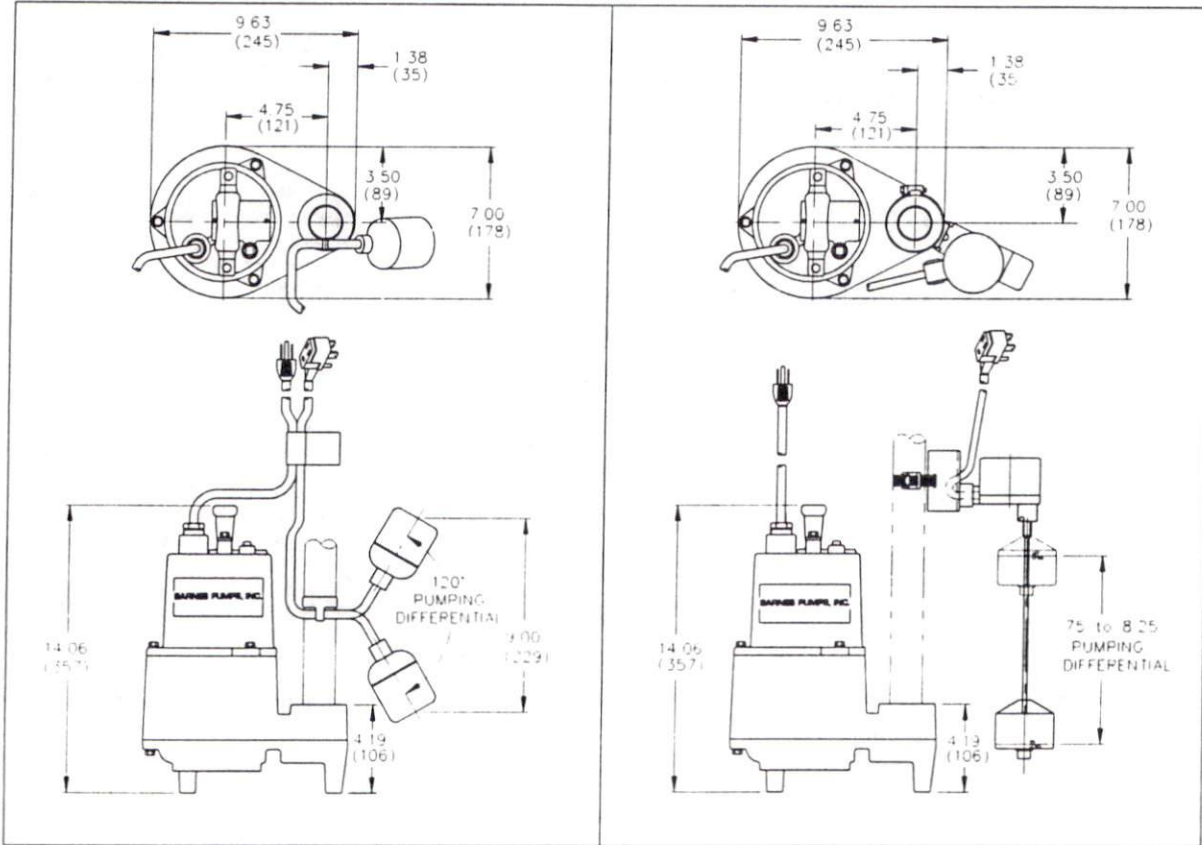

MODEL NO.	PART NO.	HP	VOLT	PH	RPM (NOM)	NEMA START CODE	FULL LOAD AMPS	CORD LENGTH	CORD SIZE	CORD TYPE
EHV412	101298	0.5	115	1	3450	H	9.40	20Ft. (6M)	14/3	SJTOW
EHV412A	103542	0.5	115	1	3450	H	9.40	20Ft. (6M)	14/3	SJTOW
EHV412VF	101300	0.5	115	1	3450	H	9.40	20Ft. (6M)	14/3	SJTOW
EHV412AT	103543	0.5	115	1	3450	H	9.40	20Ft. (6M)	14/3	SJTOW
EHV412	101298G	0.5	115	1	3450	H	9.40	30Ft. (9M)	14/3	SJTOW

**IMPORTANT !**

- 1.) PUMP MAY BE OPERATED "DRY" FOR EXTENDED PERIODS WITHOUT DAMAGE TO MOTOR AND/OR SEALS.
- 2.) THIS PUMP IS APPROPRIATE FOR THOSE APPLICATIONS SPECIFIED AS CLASS I DIVISION II HAZARDOUS LOCATIONS.
- 3.) THIS PUMP IS NOT APPROPRIATE FOR THOSE APPLICATIONS SPECIFIED AS CLASS I DIVISION I HAZARDOUS LOCATIONS.
- 4.) INSTALLATIONS SUCH AS DECORATIVE FOUNTAINS OR WATER FEATURES PROVIDED FOR VISUAL ENJOYMENT MUST BE INSTALLED IN ACCORDANCE WITH THE NATIONAL ELECTRIC CODE ANSI/NFPA 70 AND/OR THE AUTHORITY HAVING JURISDICTION. THIS PUMP IS NOT INTENDED FOR USE IN SWIMMING POOLS, RECREATIONAL WATER PARKS, OR INSTALLATIONS IN WHICH HUMAN CONTACT WITH PUMPED MEDIA IS A COMMON OCCURRENCE.

**CRANE**

A Crane Co. Company

**PUMPS & SYSTEMS**

Barnes Pumps, Inc.  
 Service Parts & Warranty Dept.  
 420 Third Street/P.O. Box 603  
 Piqua, Ohio 45356-0603  
 Ph: (937) 615-3599  
 Fax: (937) 773-7157

Barnes Pumps, Inc.  
 Sales Office  
 1485 Lexington Ave.  
 Mansfield, Ohio 44907-2674  
 Ph: (419) 774-1511  
 Fax: (419) 774-1530

Barnes Pumps Canada, Inc.  
 83 West Drive  
 Bramalea, Ontario  
 Canada L6T 2J6  
 Ph: (905) 457-6223  
 Fax: (905) 457-2650



Lot 6m-8m, Captain's 1 ding

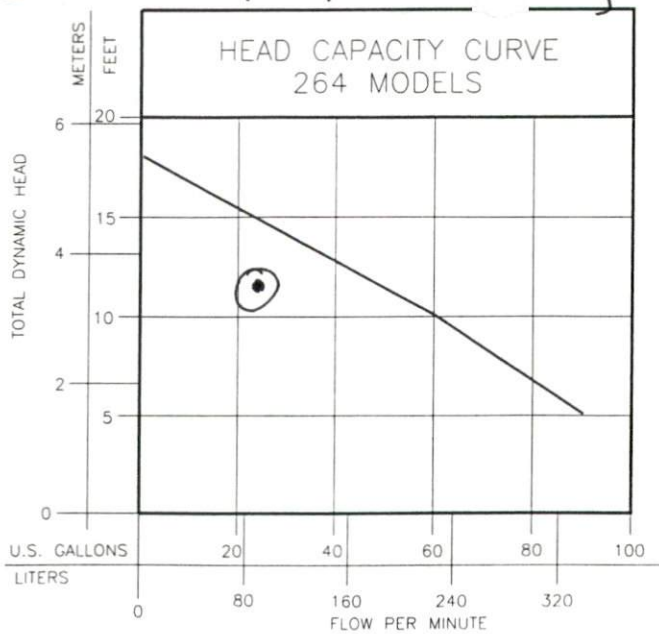

TOTAL DYNAMIC HEAD/CAPACITY PER MINUTE SEWAGE AND DEWATERING

264 MODELS			
Ft.	Meters	Gal.	Ltrs.
5	1.52	90	341
10	3.05	60	227
15	4.57	22.5	85
Lock Valve:		18 ft.	

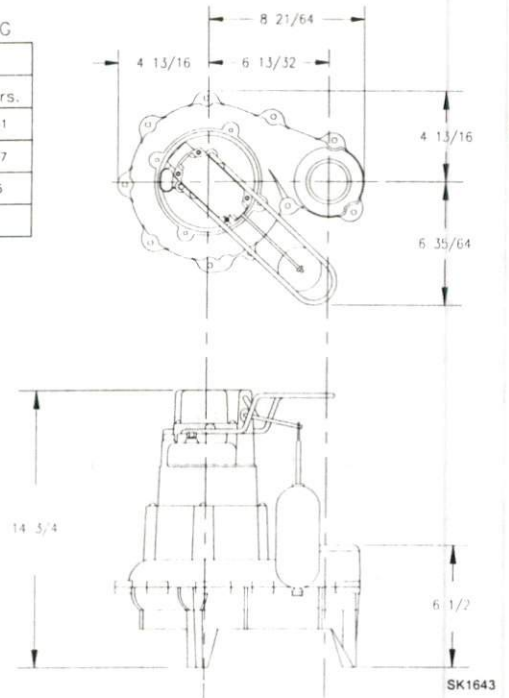

### CONSULT FACTORY FOR SPECIAL APPLICATIONS

- Electrical alternators for duplex systems available with variable level float switches.
- Minimum recommended basin size  
Simplex-18"x30"  
Duplex-30"x30"
- Standard Automatic - Weight 39 lbs. .4 H.P.
- High water alarms available.
- Mechanical alternators available for duplex systems.

**CAUTION** Maximum temperature of sewage or dewatering must be limited to 130° F. (54° C.) For over 130° F. (54° C.) special quotation required.

264 MODELS				CONTROL SELECTION		
Model	Volts	Ph	Mode	Amps	Simplex	Duplex
M264	115	1	Auto	9.4	1 or 1 & 7	—
N264	115	1	Non	9.4	2 or 2 & 6	3 or 4 & 5
D264	230	1	Auto	4.7	1 or 1 & 7	—
E264	230	1	Non	4.7	2 or 2 & 6	3 or 4 & 5

### SELECTION GUIDE

1. Integral float operated 2-pole mechanical switch, no external control required.
2. Single piggyback variable level float switch, or double piggyback variable level float switch. Refer to FM0477.
3. Mechanical alternator M-Pak 10-0072 or 10-0075.
4. See FM0712 for correct model of electrical alternator.
5. Control switch 10-0225 used as a control activator specify duplex (3) or (4) float system.

For information on additional Zoeller products refer to catalog on Piggyback Variable Level Float Switches, FM0477; Electrical Alternator, FM0486; Mechanical Alternator, FM0495; Sump/Sewage Basins, FM0487, and Single Phase Simplex Pump Control, FM1596; Alarm System, FM0732.

### CAUTION

All installation of controls, protection devices and wiring should be done by a qualified licensed electrician. All electrical and safety codes should be followed including the most recent National Electric Code (NEC) and the Occupational Safety and Health Act (OSHA).

### RESERVE POWERED DESIGN

For unusual conditions a reserve safety factor is engineered into the design of every Zoeller pump.



**ZOELLER**  
PUMP CO.

MAIL TO: P.O. BOX 16347  
Louisville, KY 40256-0347  
SHIP TO: 3649 Cane Run Road  
Louisville, KY 40211-1961  
(502) 778-2731 • 1 (800) 928-PUMP  
FAX (502) 774-3624

Manufacturers of . . .

"QUALITY PUMPS SINCE 1939"

<http://www.zoeller.com>

Lot 6M-8M, Captain's ending  
"QUALITY PUMPS SINCE 1939"

Product information presented here reflects conditions at time of publication. Consult factory regarding discrepancies or inconsistencies.



**ZOELLER**  
PUMP CO.



SECTION: 2.30.015

FM1495

0500

Supersedes

1097

MAIL TO: P.O. BOX 16347 • Louisville, KY 40256-0347  
SHIP TO: 3649 Cane Run Road • Louisville, KY 40211-1961  
(502) 778-2731 • 1 (800) 928-PUMP • FAX (502) 774-3624

visit our web site:  
<http://www.zoeller.com>

## COMPARE THESE FEATURES

- Non-Clogging Vortex Impeller Design.
- Float operated, submersible (NEMA 6) 2 pole switch.
- Durable cast iron construction. Cast iron switch cap, motor, and pump housing.
- Stainless steel screws, bolts, handle, guard, arm and seal assembly.
- Engineered, glass-filled, plastic impeller with metal insert.
- UL-listed 3-wire cord and plug. 15 ft. cord standard for automatic & nonautomatic.
- Corrosion resistant powder coated epoxy finish.
- Thermal overload protection.
- Oil filled PSC motor - hermetically sealed.
- Engineered plastic base.
- .4 H.P. 115V & 230V, 1Ph., 60 cycle, 1725 RPM.
- Carbon and ceramic shaft seal.
- Oil Lubricated Bearings.
- Passes 2-inch spherical solids.
- 2" NPT Discharge.
- On point - 12½"
- Off point - 4½"

## SIMPLEX AND DUPLEX SYSTEMS AVAILABLE



**ZOELLER**  
PUMP CO.

Manufacturers of . . .

"QUALITY PUMPS SINCE 1939"

## 264 SERIES "WASTE-MATE"

(For Pump Prefix Identification see News & Views 0052)

SUBMERSIBLE  
SEWAGE/EFFLUENT\*  
OR DEWATERING PUMP  
2" NPT DISCHARGE



POWDER  
COATED  
TOUGH™

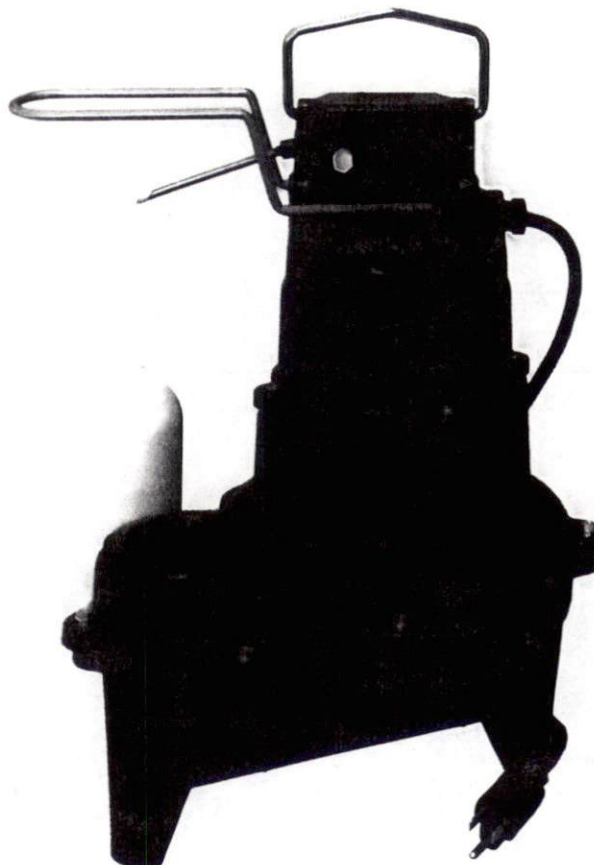

### MODELS AVAILABLE

- Automatic
- Nonautomatic (for variable level systems)
- BE & BN264 available packaged with Piggyback variable level float switch.

\*May be used in those states where codes do not restrict solids size in effluent systems.

© Copyright 2000 Zoeller Co. All rights reserved.

Lot 6M-8M, Captain's Landing

# ENGINEERING DETAILS - SW25/33

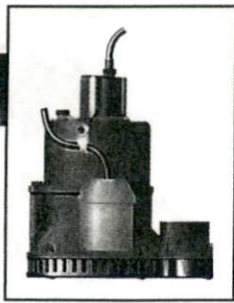

## Pump Characteristics

Pump/Motor Unit	Submersible	
Manual Models	SW25M1	SW33M1
Automatic Models	SW25A1	SW33A1
Horsepower	1/4	1/3
Full Load Amps	8.0	10.0
Motor Type	Shaded Pole (4 pole)	
R.P.M.	1550	
Phase Ø	1	
Voltage	115	
Hertz	60	
Operation	Intermittent	
Temperature	120°F Ambient	
NEMA Design	A	
Insulation	Class A	
Discharge Size	1-1/2" NPT	
Solids Handling	1/2"	
Unit Weight	30 lbs.	
Power Cord	18/3, SJTW, 10' std. (20' optional)	

## Materials of Construction

Handle	Steel
Lubricating Oil	Dielectric Oil
Motor Housing	Cast Iron
Pump Casing	Cast Iron
Shaft	Steel
Mechanical Shaft Seal	Seal Faces: Carbon/Ceramic Seal Body: Anodized Steel Spring: Stainless Steel Bellows: Buna-N
Impeller	Thermoplastic
Upper Bearing	Bronze Sleeve Bearing
Lower Bearing	Single Row Ball Bearing
Strainer/Base	Plastic
Fasteners	Stainless Steel

## Performance Data

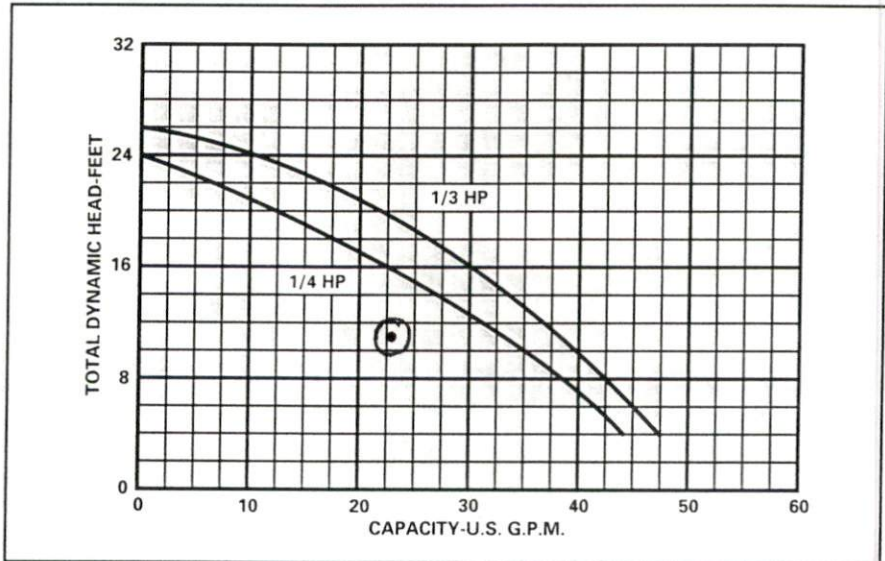

Total Head (feet)	4	6	8	10	12	14	16	18	20	22	24
<b>GPM</b> 1/4 HP	44	41	36	33	29	26	23	18	12	6	0
1/3 HP	47	45	43	40	37	34	30	26	22	16	10

## Dimensional Data

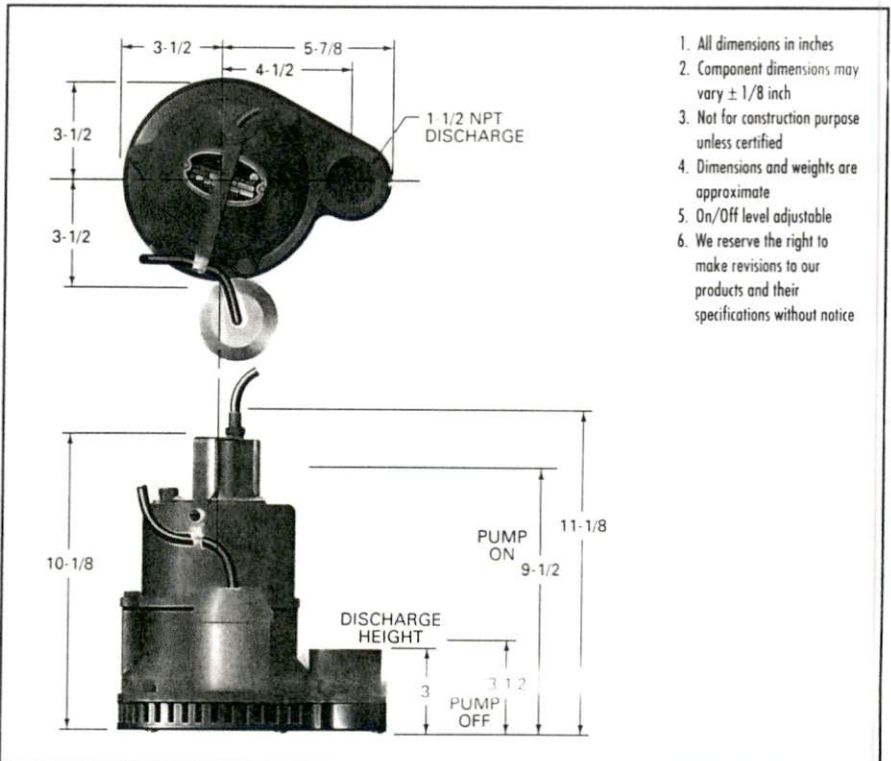

1. All dimensions in inches
2. Component dimensions may vary ± 1/8 inch
3. Not for construction purpose unless certified
4. Dimensions and weights are approximate
5. On/Off level adjustable
6. We reserve the right to make revisions to our products and their specifications without notice

**AURORA/HYDROMATIC Pumps, Inc.**  
 1840 Baney Road, Ashland, Ohio 44805  
 (419) 289-3042

Lot 6M-8M Captain's Landing

# HYDROMATIC SW25/33

Submersible Sump/Effluent Pump

- Basement Sumps
- Septic Tank Effluent
- Industrial Circulators
- Transfer Tanks



AURORA PUMP **GS**  
A UNIT OF GENERAL SIGNAL

© 1994 Aurora Pump Co., Northbrook, Illinois

# MODEL 112 Control Panel

## Single phase, simplex motor contactor control.

The Model 112 control panel provides a reliable means of controlling one 120, 208, or 240 VAC single-phase pump in pump chambers, sump pump basins, irrigation systems and lift stations. Two control switches activate a magnetic motor contactor to turn the pump on and off. If an alarm condition occurs, an additional alarm switch activates the audio/visual alarm system.

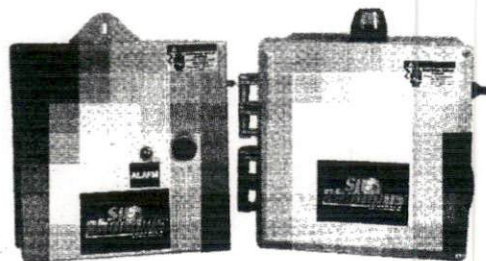

indoor

indoor/outdoor

Model Shown  
1121W914X

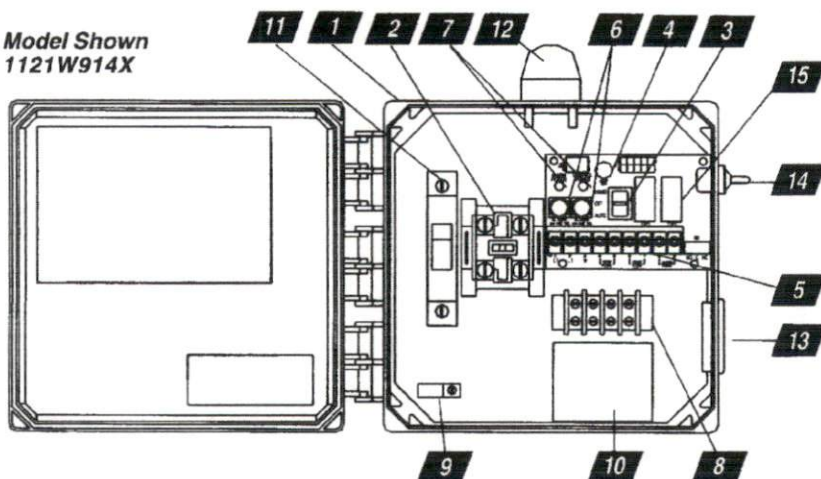

1. **Enclosure** measures 8 x 8 x 4 inches (20.32 X 20.32 X 10.16 cm). Choice of NEMA 1 (steel for indoor use), or NEMA 4X (ultraviolet stabilized thermoplastic with removable flanges for outdoor or indoor use).  
\* Options selected may increase enclosure size and change component layout.
2. **Magnetic Motor Contactor** controls pump by switching hot electrical lines.
3. **HOA Switch** for manual pump control (mounted on circuit board).
4. **Green Pump Run Indicator Light** (mounted on circuit board).
5. **Float Switch Terminal Block** (mounted on circuit board).
6. **Alarm and Control Fuses** (mounted on circuit board).
7. **Alarm and Control Power Indicators** (mounted on circuit board).
8. **Pump Input Power and Pump Connection Terminal Block**
9. **Ground Lug**
10. **Terminal Block Installation Label**
11. **Circuit Breaker** (optional) provides pump disconnect and branch circuit protection.

### STANDARD ALARM PACKAGE (other options available)

12. **Red Alarm Beacon** provides 360° visual check of alarm condition.  
**Note:** NEMA 1 style utilizes a door mounted indicator in lieu of a beacon.
13. **Alarm Horn** provides audio warning of alarm condition (83 to 85 decibel rating).  
**Note:** NEMA 1 style utilizes an internally mounted buzzer (83 to 85 decibel) in lieu of horn.
14. **Exterior Horn Test/Normal/Silence Switch** allows alarm horn to be silenced and testing of horn and light to ensure proper operation of alarm system.
15. **Horn Silence Relay** automatically resets alarm after alarm condition has been resolved (mounted on circuit board).

## FEATURES

- Entire control system (panel and switches) is UL Listed to meet and/or exceed industry safety standards
- Dual safety certification for the United States and Canada
- Standard package includes three 20' Sensor Float® control switches
- Complete with step-by-step installation instructions
- Three-year limited warranty



**SJE-Rhombus**  
SJ ELECTRO SYSTEMS, INC.

PO Box 1708, Detroit Lakes, MN 56502

1-888-DIAL-SJE • 1-218-847-1317

1-218-847-4617 Fax

email: sje@sjerhombus.com

[www.sjerhombus.com](http://www.sjerhombus.com)

# Lot 6M-8M, Captain's Landing Subdivision

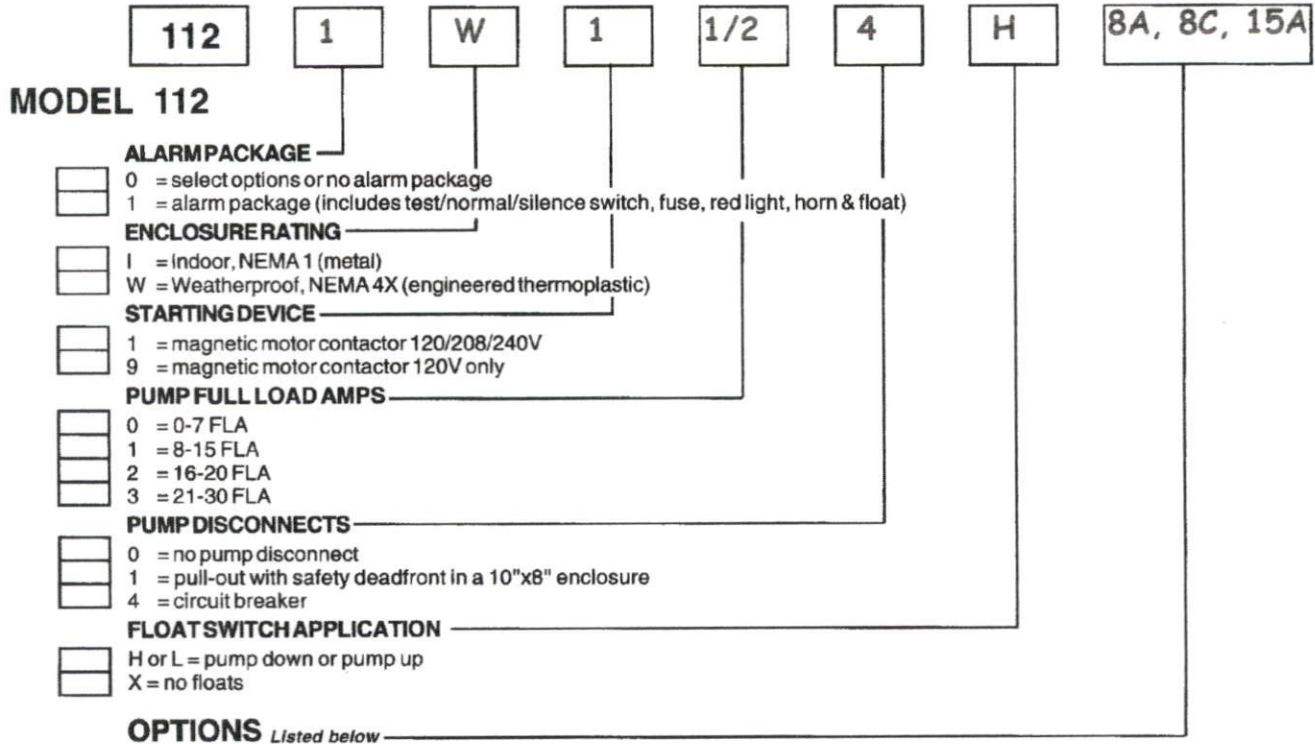

★ Options selected may increase enclosure size and change component layout.

*If additional features are required, call the factory for a quote on either a Pro-Line or Engineered Custom control panel system.*

- |  |  |
|--|--|
| <p><b>CODE DESCRIPTION</b></p> <ul style="list-style-type: none"> <li><input type="checkbox"/> 1A Red beacon only / no audio<br/><i>must select 1E if floats included</i></li> <li><input type="checkbox"/> 1C Horn only / no visual<br/><i>must select 1E if floats included</i></li> <li><input type="checkbox"/> 1E Alarm float</li> <li><input type="checkbox"/> 3A Alarm flasher</li> <li><input type="checkbox"/> ★ 4A Low level cutout<br/><i>select option 4D if floats included</i></li> <li><input type="checkbox"/> ★ 4B Red low-level indicator &amp; alarm<br/><i>must select 4A also</i></li> <li><input type="checkbox"/> 4D Low-level float</li> <li><input type="checkbox"/> 6A Auxiliary alarm contact, form C type</li> <li><input type="checkbox"/> ★ 8A Elapsed time meter</li> <li><input type="checkbox"/> ★ 8C Event (cycle) counter</li> <li><input type="checkbox"/> 10E Lockable latch - NEMA 4X</li> <li><input type="checkbox"/> 10E Lockable latch - NEMA 1</li> <li><input type="checkbox"/> ★ 10F Lightning arrester</li> <li><input type="checkbox"/> ★ 10K Anti-condensation heater</li> </ul> | <p><b>CODE DESCRIPTION</b></p> <ul style="list-style-type: none"> <li><input type="checkbox"/> 11C NEMA 1 alarm panel <i>must select option 6A</i></li> <li><input type="checkbox"/> 11D NEMA 4X alarm panel <i>must select option 6A</i></li> <li><input type="checkbox"/> 15A Control / alarm circuit breaker<br/><i>Does not include the circuit board as in standard.</i></li> <li><input type="checkbox"/> 16A 10' cord in lieu of 20'</li> <li><input type="checkbox"/> 16B 15' cord in lieu of 20'</li> <li><input type="checkbox"/> 16C 30' cord in lieu of 20'</li> <li><input type="checkbox"/> 16D 40' cord in lieu of 20'</li> <li><input type="checkbox"/> 17A SJE SignalMaster® / mounting strap ●</li> <li><input type="checkbox"/> 17B SJE SignalMaster® / externally weighted ●</li> <li><input type="checkbox"/> 17C Sensor Float® / internally weighted ▲</li> <li><input type="checkbox"/> 17D Sensor Float® / externally weighted ▲</li> <li><input type="checkbox"/> 17E Sensor Float® Mini / pipe clamp ▲</li> <li><input type="checkbox"/> 17F Sensor Float® Mini / externally weighted ▲</li> <li><input type="checkbox"/> 19X Door mounted pump run indicator</li> <li><input type="checkbox"/> 21A Pumpmaster® in lieu of on/off switches ●</li> <li><input type="checkbox"/> 21B PumpMaster® Plus in lieu of on/off switches ●</li> <li><input type="checkbox"/> 21C Super Single® in lieu of on/off switches ▲</li> <li><input type="checkbox"/> 21D Double Float™ in lieu of on/off switches ▲</li> </ul> <p style="text-align: center;">● Mechanically-activated    ▲ Mercury-activated</p> |
|--|--|

## SAMPLE

