

IMPROVEMENT PERMIT

03-5-7095

Be it ordained by the Harnett County Board of Health as follows: Section III, Item B. "No Person shall begin construction of any building at which a septic tank system is to be used for disposal of sewage without first obtaining a written permit from the Harnett County Health Department."

Name: (owner) Linda Newton New Installation Septic Tank

Property Location: SR# Newton Rd Repairs Nitrification Line

off of South River Road

Subdivision _____ Lot # _____

Tax ID # _____ Quadrant # _____

Number of Bedrooms Proposed: 2 (30x60) Lot Size: 1.00 AC

Basement with Plumbing: Garage:

Water Supply: Well Public Community

Distance From Well: 50 ft.

Following is the minimum specifications for sewage disposal system on above captioned property. Subject to final approval.

Type of system: Conventional Other _____

Size of tank: Septic Tank: 1000 gallons Pump Tank: _____ gallons

Subsurface Drainage Field No. of ditches 3 exact length 80 width of 3 depth of 18 1/4 in.

French Drain Required: _____ Linear feet

Date: 5-22-03

This permit is subject to revocation if site plans or intended use change.

Signed: [Signature] Environmental Health Specialist

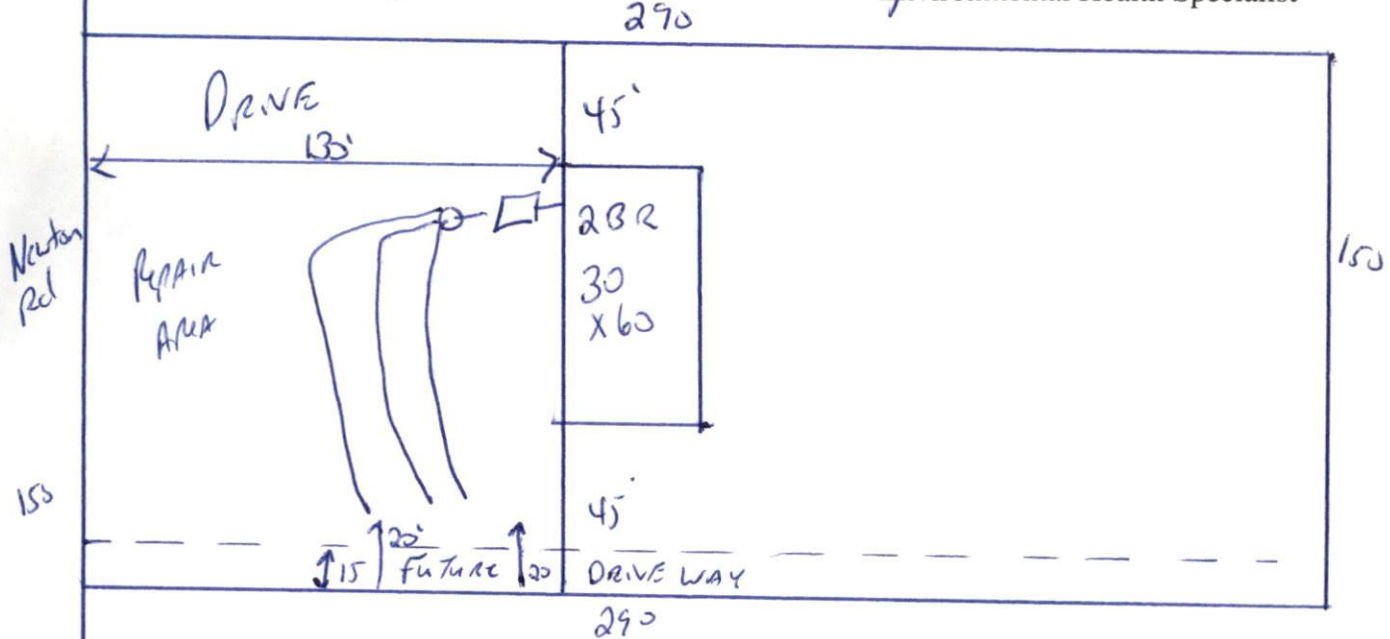

STUB out Plumbing shallow MAINTAIN ALL setBACKS
 Do not DRIVE OR park on septic system
 MAINTAIN 20' from Property line with future driveway along it

