

# IMPROVEMENT PERMIT

Be it ordained by the Harnett County Board of Health as follows: Section III, Item B. "No Person shall begin construction of any building at which a septic tank system is to be used for disposal of sewage without first obtaining a written permit from the Harnett County Health Department."

Name: (owner) Homesmart

- New Installation
- Septic Tank
- Repairs
- Nitrification Line

Property Location: SR# 1535 Mitchell

Subdivision \_\_\_\_\_ Lot # 1

Tax ID # \_\_\_\_\_ Quadrant # \_\_\_\_\_

Number of Bedrooms Proposed: 3 Lot Size: 6 acres

Basement with Plumbing:  Garage:

Water Supply:  Well  Public  Community

Distance From Well: 50' ft.

Following is the minimum specifications for sewage disposal system on above captioned property. Subject to final approval.

Type of system:  Conventional  Other \_\_\_\_\_

Size of tank: Septic Tank: 1000 gallons Pump Tank: \_\_\_\_\_ gallons

Subsurface Drainage Field No. of ditches 5 exact length of each ditch 80 ft. width of ditches 3 ft. depth of ditches 18-20 in.

French Drain Required: — Linear feet

Date: 4-16-03

This permit is subject to revocation if site plans or intended use change.

Signed: James E. Manhart, R.S.  
Environmental Health Specialist

*Replaces Permit # 19963*

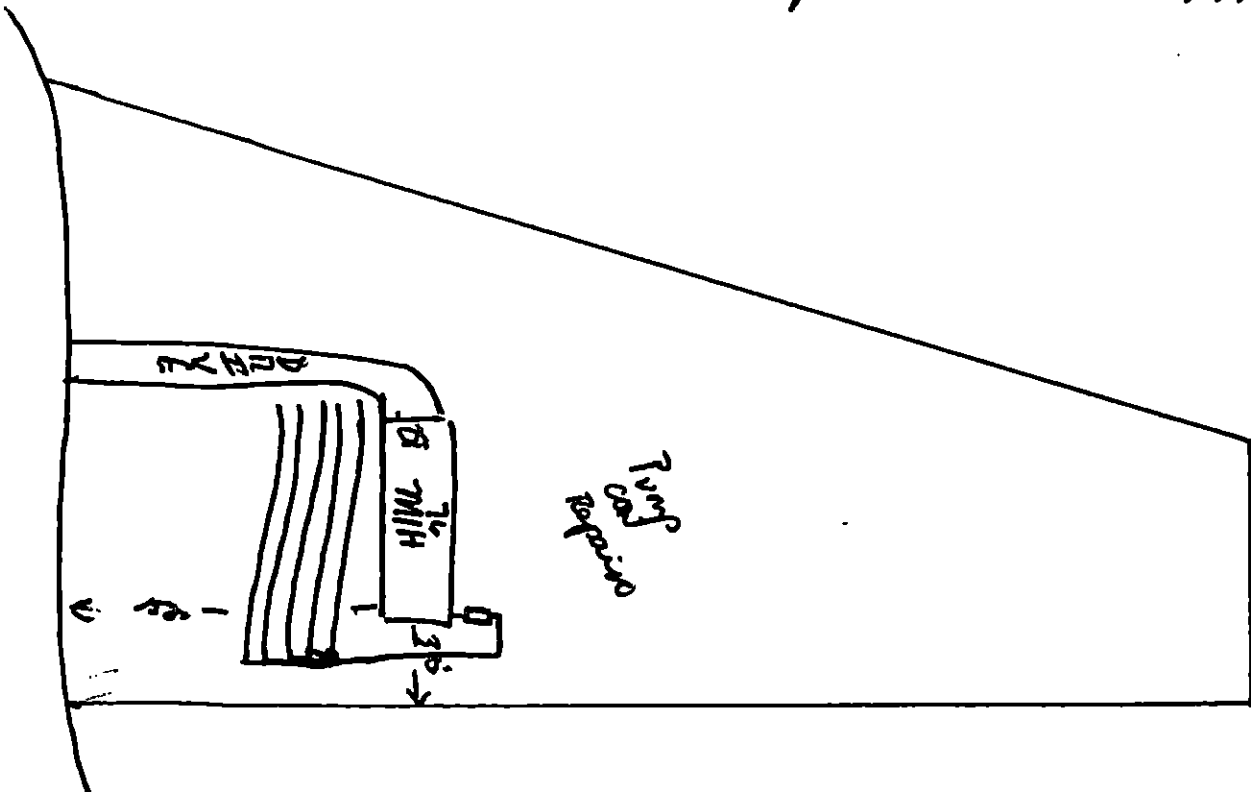

# 03-5-6676 B

HARNETT COUNTY HEALTH DEPARTMENT  
AUTHORIZATION TO CONSTRUCT

Authorization is hereby given to construct a wastewater system to the specifications described by Harnett County Health Department, Improvement Permit # 19973. This authorization shall be valid for a period not to exceed five (5) years from the date of issuance. This authorization will be invalid if ownership, site plans, or intended use change.

Name Homesmart Telephone# 919-630-0408  
5317 Fayetteville Rd

Address ~~2037 Harnett Ave~~ Raleigh N.C. 27603

Property Location SR# 1535 Road Name Mitchell Rd

Subdivision \_\_\_\_\_ Lot # 1 # Bedrooms Proposed 3 Lot Size 6 acres

TYPE OF SYSTEM

New Installation  Repair  Septic Tank  Nitrification Lines

Conventional  Other \_\_\_\_\_

Basement  With Plumbing  Without Plumbing

Water Supply:  Well  Public Water Supply Minimum Well Setback: 50' Ft.

Septic Tank 1000 gal Pump Chamber \_\_\_\_\_ gal

NITRIFICATION FIELD SPECIFICATIONS

Number of fields 2 # of lines per field 5 Length of lines 50 Ft.

Width of ditches 3 ft. Depth of ditches 18-20 inches

French Drain: Linear feet required \_\_\_\_\_ Depth of gravel \_\_\_\_\_

No wastewater system shall be covered or placed into use by any person until an inspection by the Harnett County Health Department has determined that the system has been installed according to the conditions of the Improvement Permit and that a valid Operations Permit has been issued.

James E. Markham  
Signature of Authorized Agent for Harnett County of Harnett

4-16-03  
Date