

COMMENTS: _____

LANDSCAPE POSITIONS	GROUP	TEXTURES	.1955 LTAR	CONSISTENCE MOIST	WET
R-RIDGE	I	S-SAND	1.2 - 0.8	VFR-VERY FRIABLE FR-FRIABLE FI-FIRM VFI-VERY FIRM EFI-EXTREMELY FIRM	NS-NON-STICKY SS-SLIGHTLY STICKY S-STICKY VS-VERY STICKY NP-NON-PLASTIC SP-SLIGHTLY STICKY P-PLASTIC VP-VERY PLASTIC
S-SHOULDER SLOPE		LS-LOAMY SAND			
L-LINEAR SLOPE	II	SL-SANDY LOAM	0.8 - 0.6		
FS-FOOT SLOPE		L-LOAM			
N-NOSE SLOPE	III	SI-SILT-	0.6 - 0.3		
H-HEAD SLOPE		SIL-SILT LOAM			
CC-CONCLAVE SLOPE		CL-CLAY LOAM			
CV-CONVEX SLOPE		SCL-SANDY CLAY LOAM			
T-TERRACE	IV	SIC-SILTY CLAY	0.4 - 0.1		
FP-FLOOD PLAN		C-CLAY			
		SC-SANDY CLAY			

STRUCTURE

- SG-SINGLE GRAIN
- M-MASSIVE
- CR-CRUMB
- GR-GRANULAR
- SBK-SUBANGULAR BLOCKY
- ABK-ANGULAR BLOCKY
- PL-PLATY
- PR-PRISMATIC

MINERALOGY

- SLIGHTLY EXPANSIVE
- EXPANSIVE

Show profile locations and other site features (dimensions, reference or benchmark, and North).

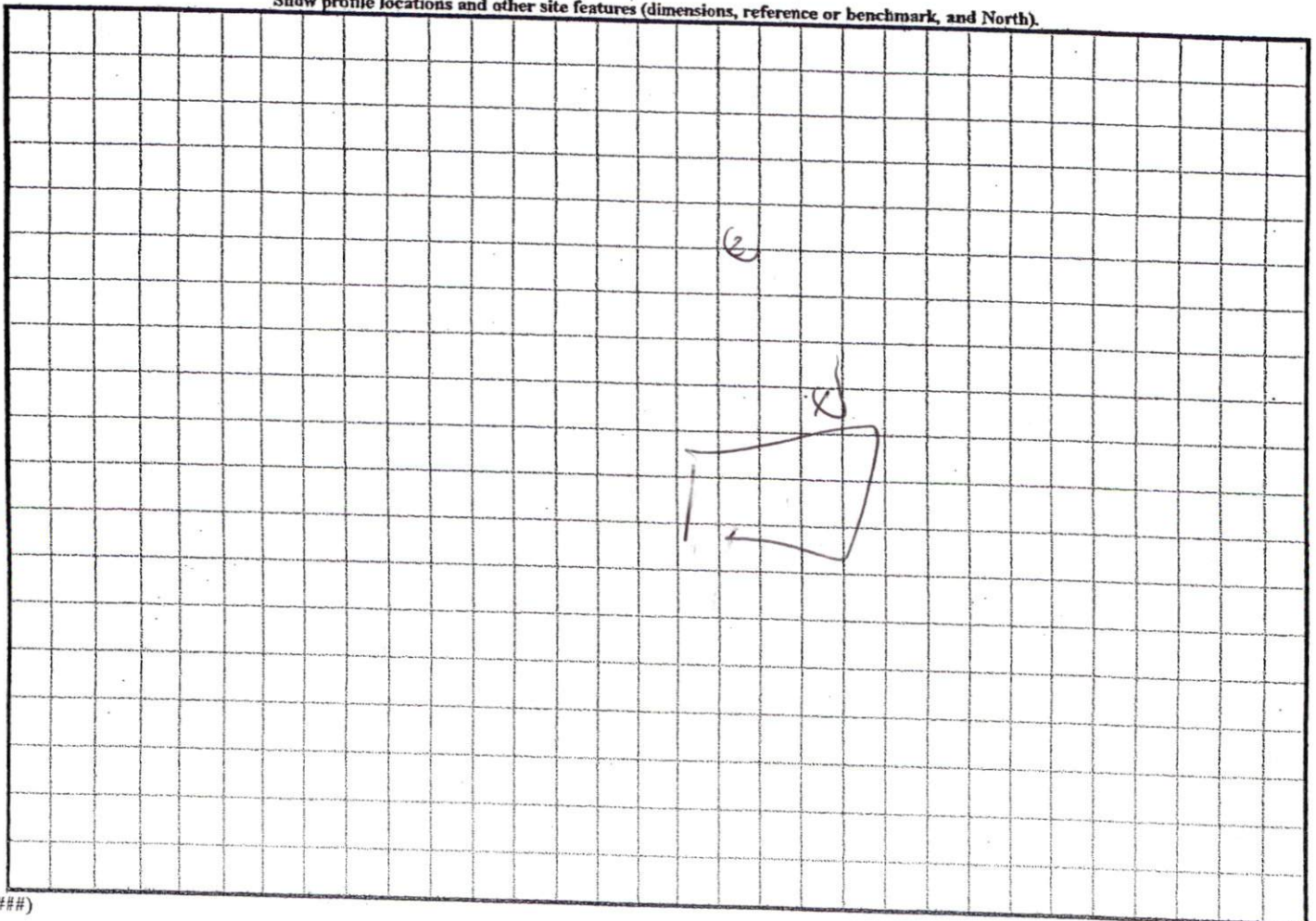

1"=50'

Nathan Mashburn
Contact Lee Johnson
919-630-0408

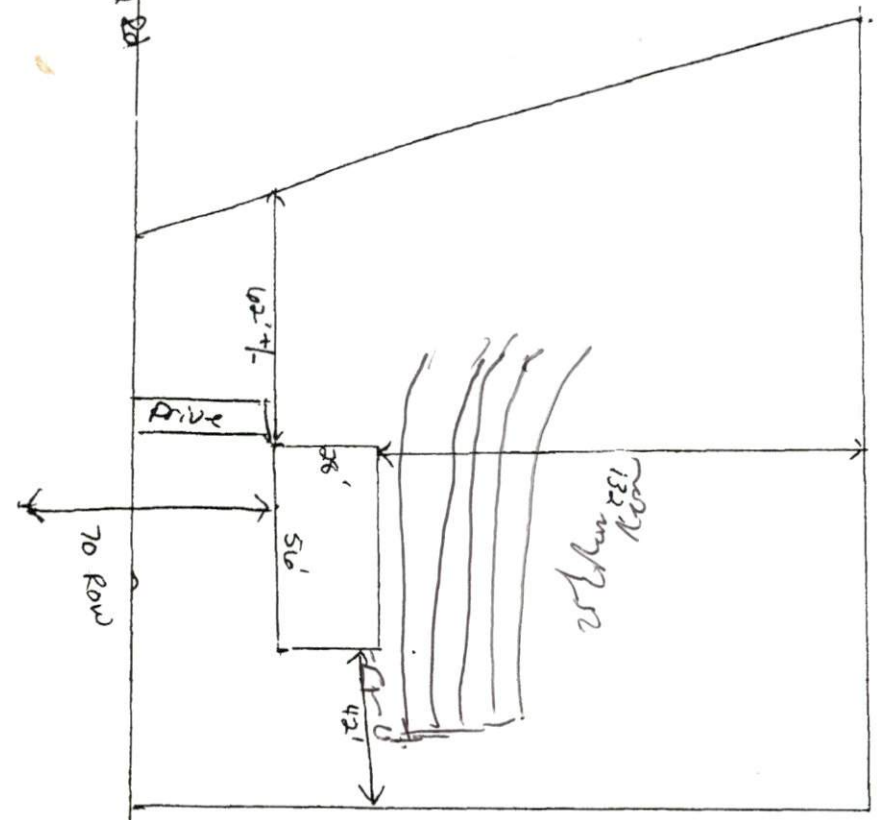

← Stockpiles Rd

Ray Bryd Rd

SITE PLAN APPROVAL

DISTRICT R100R USE DWMT

#BEDROOMS 3

Date 03/07/2005 A. Druggus
Planning Administrator

Julia Cardone