

Initial Application Date: 11/1/04

App # 04500/0706

COUNTY OF HARNETT LAND USE APPLICATION
Central Permitting 102 E. Front Street, Lillington, NC 27546 Phone: (910) 893-4759 Fax: (910) 893-2793

776477

LANDOWNER: Curtis L. Batchelor Mailing Address: 4354 NC 87 N
City: SANFORD State: NC Zip: 27330 Phone #: 499-4754
APPLICANT: Curtis L. Batchelor Mailing Address: 4354 NC 87 N
City: SANFORD State: NC Zip: 27330 Phone #: 499-4754

PROPERTY LOCATION: SR #: 87 SR Name: 87
Address: 141 Sandstone
Parcel: 039597 0099 PIN: 9568-78-5111.000
Zoning: RA20R Subdivision: — Lot #: — Lot Size: 15.68
Flood Plain: X Panel: 75 Watershed: n/a Deed Book/Page: 261/310 Plat Book/Page: 515

DIRECTIONS TO THE PROPERTY FROM LILLINGTON:
24-27 to Highway 87 1/2 mile north of Olivia on 87

PROPOSED USE:

- Sg. Family Dwelling (Size — x —) # of Bedrooms — # Baths — Basement (w/wo bath) — Garage — Deck —
 - Multi-Family Dwelling No. Units — No. Bedrooms/Unit —
 - Manufactured Home (Size 14 x 70) # of Bedrooms 3 Garage — Deck porches - 2
 - Number of persons per household 1
 - Business Sq. Ft. Retail Space — Type —
 - Industry Sq. Ft. — Type —
 - Church Seating Capacity — Kitchen —
 - Home Occupation (Size — x —) # Rooms — Use —
- Additional Information: —
- Accessory Building (Size — x —) Use —
 - Addition to Existing Building (Size — x —) Use —
 - Other —

Additional Information: —
Water Supply: () County () Well (No. dwellings —) () Other
Sewage Supply: () New Septic Tank () Existing Septic Tank () County Sewer () Other
Erosion & Sedimentation Control Plan Required? YES NO
Property owner of this tract of land own land that contains a manufactured home w/in five hundred feet (500') of tract listed above? YES () NO
Structures on this tract of land: Single family dwellings — Manufactured homes 1 proposed Other (specify) —

Required Residential Property Line Setbacks:	Minimum	Actual
Front	35	720
Rear	25	230'
Side	10	320'
Corner	20	—
Nearest Building	10	—

If permits are granted I agree to conform to all ordinances and the laws of the State of North Carolina regulating such work and the specifications or plans submitted. I hereby swear that the foregoing statements are accurate and correct to the best of my knowledge.

Curtis L. Batchelor 11-1-04
Signature of Owner or Owner's Agent Date

This application expires 6 months from the initial date if no permits have been issued

A RECORDED SURVEY PLAT AND RECORDED DEED ARE REQUIRED WHEN APPLYING FOR A LAND USE APPLICATION

IVR 11/12/04

SITE PLAN APPROVAL

DISTRICT RAZOR USE SwmH

#BEDROOMS 2

Date 11/2/04 Zoning Administrator PRUSSELL

Martin J Batchelor

NC 67N

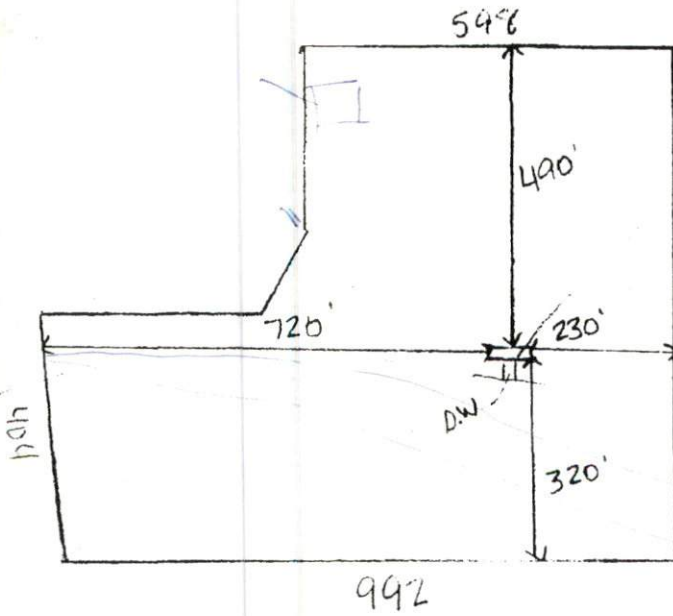

Proposed SwmH

730

Sanitary

1=30

SITE PLAN APPROVAL

DISTRICT RA20R USE SwmH

#BEDROOMS 23

112104 PRUSSELL

Date 11/16/04 Zoning Administrator

Martin J Batchelor

