

HTE 04-5-9972R

IMPROVEMENT PERMIT

21203

Be it ordained by the Harnett County Board of Health as follows: Section III, Item B. "No Person shall begin construction of any building at which a septic tank system is to be used for disposal of sewage without first obtaining a written permit from the Harnett County Health Department."

Name: (owner) GREGORY MILLER
Property Location: SR# NC24 (OAKWATER DR)
New Installation, Septic Tank, Repairs, Nitrification Line

Subdivision BRIDLEWOOD HILLS Lot # 1

Tax ID # Quadrant #

Number of Bedrooms Proposed: 3 Lot Size: 1.76 ac

Basement with Plumbing: Garage:

Water Supply: Well, Public, Community

Distance From Well: 50 ft.

Following is the minimum specifications for sewage disposal system on above captioned property. Subject to final approval.

Type of system: Conventional, Other

Size of tank: Septic Tank: 1000 gallons Pump Tank:

Subsurface Drainage Field: No. of ditches, exact length of each ditch, width of ditches, depth of ditches

French Drain Required: Linear feet

Date: 8/20/04

Signed: OLIVER TOLKSDORF Environmental Health Specialist

This permit is subject to revocation if site plans or intended use change.

- MAINTAIN ALL SETBACKS
CALL WITH ANY QUESTIONS PRIOR TO INSTALLATION

REVISED 8/17 04

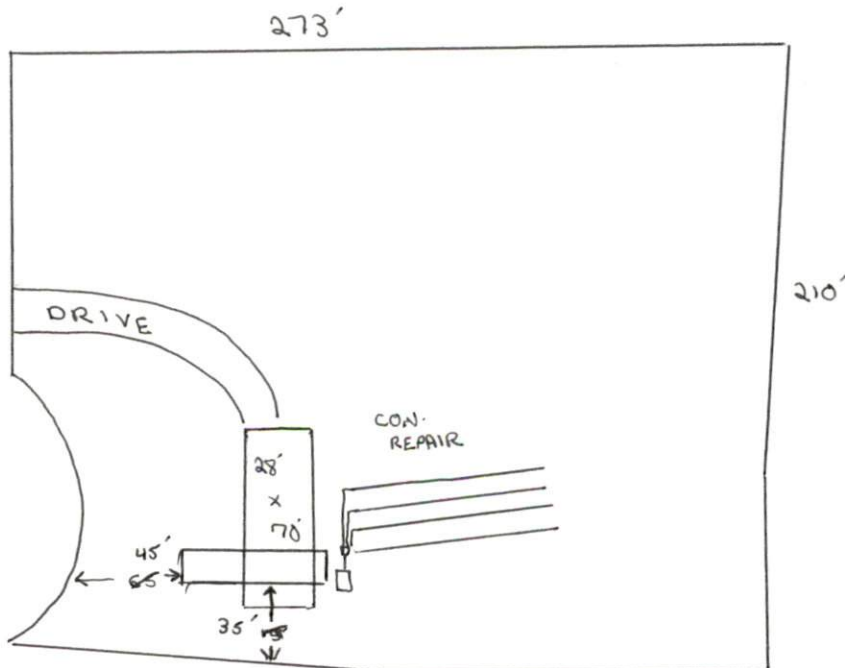

DRAWING NTS

