

03-5-7241R

HARNETT COUNTY HEALTH DEPARTMENT

No 20089

IMPROVEMENT PERMIT

Be it ordained by the Harnett County Board of Health as follows: Section III, Item B. "No Person shall begin construction of any building at which a septic tank system is to be used for disposal of sewage without first obtaining a written permit from the Harnett County Health Department."

Name: (owner) CHRIS TACIA

New Installation Septic Tank

Property Location: SR# 2035 STOCKYARD RO

Repairs Nitrification Line

Subdivision STOCKYARD RO. ESTATES II Lot # 14

Tax ID # _____ Quadrant # _____

Number of Bedrooms Proposed: 4 Lot Size: .50 AC

Basement with Plumbing: Garage:

Water Supply: Well Public Community

Distance From Well: 100 ft.

Following is the minimum specifications for sewage disposal system on above captioned property. Subject to final approval.

Type of system: Conventional Other _____

Size of tank: Septic Tank: 1000 gallons Pump Tank: _____ gallons

Subsurface Drainage Field No. of ditches 5 exact length of each ditch 80 ft. width of ^{or} ~~8~~ 3 ft. depth of ditches 18-24 in.

French Drain Required: _____ Linear feet

Date: 6/20/03

This permit is subject to revocation if site plans or intended use change.

Signed: [Signature] Environmental Health Specialist

- * MAINTAIN ALL SETBACKS
- * CALL WITH ANY QUESTIONS PRIOR TO INSTALLATION

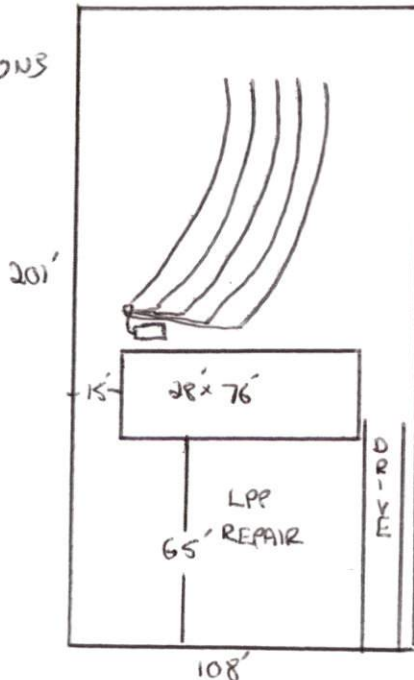

HARNETT COUNTY HEALTH DEPARTMENT
AUTHORIZATION TO CONSTRUCT

Authorization is hereby given to construct a wastewater system to the specifications described by Harnett County Health Department, Improvement Permit # 20089. This authorization shall be valid for a period not to exceed five (5) years from the date of issuance. This authorization will be invalid if ownership, site plans, or intended use change.

CHRIS TACIA 893-5222
Name Telephone#

PO Box 639 OLIVIA NC 28368
Address

2035 STOCKYARD RD
Property Location SR# Road Name

STOCKYARD RD EST II 14 4 .50 AC
Subdivision Lot # # Bedrooms Proposed Lot Size

TYPE OF SYSTEM

New Installation Repair Septic Tank Nitrification Lines

Conventional Other _____

Basement With Plumbing Without Plumbing

Water Supply: Well Public Water Supply Minimum Well Setback: 100 Ft.

Septic Tank 100 gal Pump Chamber _____ gal

NITIRFICATION FIELD SPECIFICATIONS

Number of fields 1 # of lines per field 5 Length of lines 80 Ft.

Width of ditches 3 ft. Depth of ditches 18-24 inches

French Drain: Linear feet required _____ Depth of gravel _____

No wastewater system shall be covered or placed into use by any person until an inspection by the Harnett County Health Department has determined that the system has been installed according to the conditions of the Improvement Permit and that a valid Operations Permit has been issued.

[Signature] RS 6/20/03
Signature of Authorized Agent for Harnett County of Harnett Date