



Fire Marshal Division

P.O. Box 370
Lillington, NC 27546
910-893-7580

Reviewed for Fire Code Compliance



Leslie Jackson

10/15/2024 3:26:00 PM

Application for Plan Review

Permit Type: _____

Date Received: _____ Received By: _____

Name of Project: _____

Physical Address of Project: _____

Plans Submitted By: _____

Project Phone: (_____) - ____ - ____

Contact Person/Address: _____

Contact Phone: (_____) - ____ - ____ (_____) - ____ - ____

Contractor's Name/Info: _____

Contractor's Phone: (_____) - ____ - ____

Contact Email: _____

- **Plans that are submitted will be reviewed as quickly as possible with an average time of review between 7-10 working days.**
- **Status checks may be conducted on plan reviews by visiting the website <http://hteweb.harnett.org/Click2GovBP/Index.jsp> or by calling the Harnett County Central Permitting Office (910-893-7525 : Opt. 2), or the Harnett County Fire Marshal's Office (910-893-7580).**
- **Approved plans must be picked up from the Central Permitting Office and all fees paid before any required inspections can be conducted.**



HARNETT COUNTY DSS UPFIT 2ND FLOOR FIRE ALARM SYSTEM

JOHNSON CONTROLS CONTACTS

Sales Representative

STEPHEN SANDER
STEPHEN.SANDER@JCI.COM
PHONE: 919-208-0215

Drawings Prepared By

THOMAS PALCZUK
THOMAS.PALCZUK-EXT@JCI.COM
PHONE:

Project Manager

PERRY MILLS
PERRY.MILLS@JCI.COM
PHONE: 919-971-3198

Drawings Reviewed By

JOE SIMMONS
JOE.SIMMONS@JCI.COM
PHONE: 919-455-9023

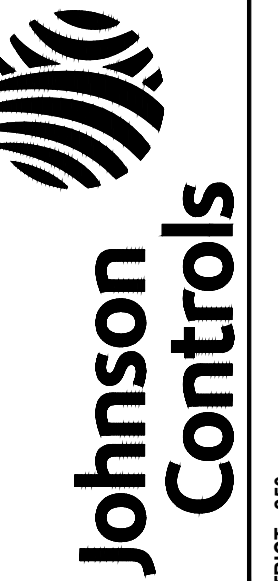

DISTRICT - 250
SUITE 105
RALEIGH, NC 27610
SERVICE: 919-279-6400
PHONE: 919-279-6400
FAX: 919-255-3401

DRAWING INDEX

LEGENDS

APPLICABLE CODES & STANDARDS

JURISDICTIONS WITHIN THE STATE MAY HAVE AMENDMENTS TO THE STATE ADOPTED CODE. CHECK WITH THE LOCAL JURISDICTION AUTHORITY FOR MORE DETAILS.
NORTH CAROLINA STATE FIRE PREVENTION CODE, 2018 EDITION (AMENDED NATIONAL FIRE CODE (IFC), 2018 EDITION)
NORTH CAROLINA STATE ELECTRICAL CODE, 2017 EDITION (AMENDED NATIONAL FIRE CODE (NFPA 70), 2017 EDITION)
NATIONAL FIRE ALARM AND SIGNALING CODE (NFPA 72), 2016 EDITION

OCCUPANCY TYPE(S):
B BUSINESS GROUP

SPRINKLER PROTECTION:
UNKNOWN

SCOPE OF WORK

MODIFY EXISTING FIRE ALARM SYSTEM: PROVIDE NEW DEVICES, RELOCATE AND DEMO EXISTING DEVICES AS SHOWN ON DRAWINGS.

ALL NEW WIRING IS TO BE CLASS B FOR NOTIFICATION APPLIANCE CIRCUITS, CLASS A FOR INITIATING DEVICE CIRCUITS, AND SIGNALING LINE CIRCUITS.

THE EXISTING FIRE ALARM SYSTEM SHALL NOT BE DISCONNECTED OR TAKEN OUT OF SERVICE WITHOUT WRITTEN PERMISSION FROM THE OWNER. IT IS THE CONTRACTOR'S RESPONSIBILITY TO COORDINATE WITH THE OWNER THE TIMING OF ANY EXISTING FIRE ALARM SYSTEM DEMOLITION WORK.

ABBREVIATIONS LEGEND

AC = ABOVE CEILING
AFF = ABOVE FINISHED FLOOR
AHJ = AUTHORITY HAVING JURISDICTION
ALM = ALARM
ANN = ANNUNCIATOR
BMS = BUILDING MANAGEMENT SYSTEM
C = CEILING MOUNTED
CD = CANDELA RATING
DET = DETECTOR
DGP = DATA GATHERING PANEL
E = EXISTING TO REMAIN
EOL = END OF LINE
EPO = EMERGENCY POWER OFF
ER = ELEVATOR RECALL
FAA = FIRE ALARM ANNUNCIATOR
FACP = FIRE ALARM CONTROL PANEL
FATO = FIRE ALARM TERMINAL CABINET
FBO = FURNISHED BY OTHERS
FCC = FIRE COMMAND CENTER
FSD = FIRE SMOKE DAMPER
FTR = FIRE ALARM TRANSPOUNDER
H = HIGH HUMIDITY
HT = HEIGHT
HVAC = HEATING VENTILATION & AIR CONDITIONING
IBMS = INFORMATION MANAGEMENT SYSTEM
MAX = MAXIMUM
MIN = MINIMUM
N/A = NOT APPLICABLE
NAC = NOTIFICATION APPLIANCE CIRCUIT
NDU = NETWORK DISPLAY UNIT

NEC = NATIONAL ELECTRIC CODE
NFPA = NATIONAL FIRE PROTECTION ASSOCIATION
NIC = NOT IN CONTRACT
NPU = NETWORK PROCESSING UNIT
NTS = NOT TO SCALE
PAP = PRE-ACTION PANEL
RC = EXISTING TO REMOVE AND COVER
RD = EXISTING DEVICE TO BE RELOCATED
RL = RELOCATED DEVICE
RR = REMOVE EXISTING & REPLACE WITH NEW
SCC = STATUS COMMAND CENTER
SLC = SIGNALING LINE CIRCUIT
SMK = SMOKE
SUPV = SUPERVISORY
TAC = TRUE/ALERT ADDRESSABLE CONTROLLER
TOS = TOP OF SHAFT
TRBL = TROUBLE
TS = TAMPER SWITCH
TYP = TYPICAL
UN = UNLESS OTHERWISE NOTED
VCC = VOICE COMMAND CENTER
VT = VALVE TAMPER
W = WATTAGE
W/O = WITHOUT
WF = WATERFLOW
WG = WIRE GUARD
WP = WEATHERPROOF
XP = EXPLOSION PROOF

PROJECT DIRECTORY

Site

HARNETT COUNTY DSS
311 W CORNELIUS HARNETT B
LILLINGTON, NC 27546

Johnson Controls District - 250

540 CIVIC BLVD, SUITE 105
RALEIGH, NC 27610
PHONE: 919-279-6400
FAX: 919-255-3401
SERVICE: 919-279-6400

General Contractor

KENNEDY ELECTRIC SERVICE LLC
1304 WHITE FLASH RD, 300 N. CHURCH ST.
MOUNT OLIVE, NC 28365

DESIGN STATEMENT

THIS PROJECT'S DESIGN IS BASED ON THE ENGINEERED PLANS AND SPECIFICATIONS PREPARED BY: ARCHITECT OR ENGINEER NAME.

ARCHITECTURAL PLANS DATED:
MECHANICAL PLANS DATED:
ELECTRICAL PLANS DATED:
SPECIFICATIONS DATED:
ADDENDUM DATED:

DEVICE TAG LEGEND

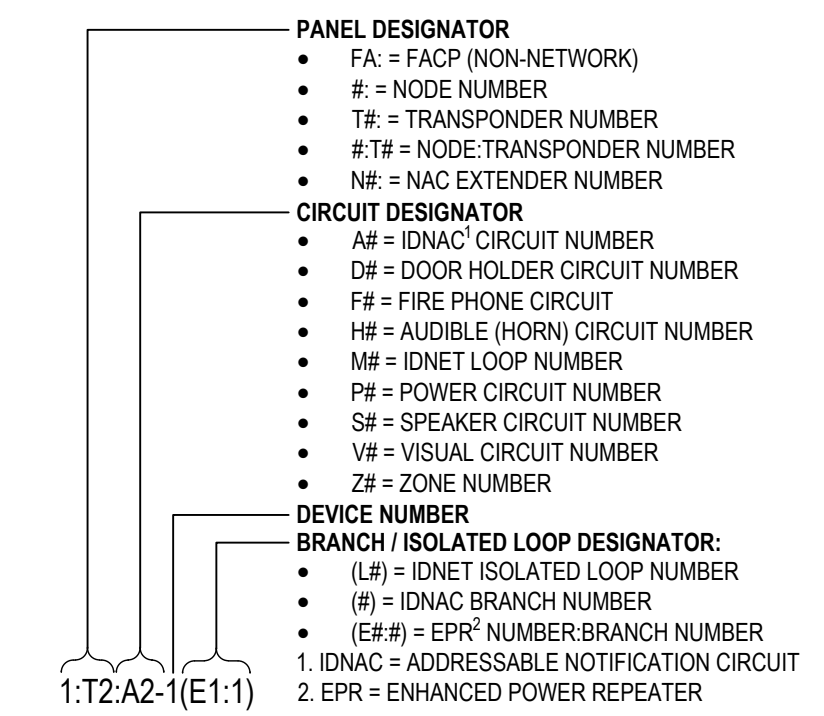

SYSTEM SEQUENCE OF OPERATIONS

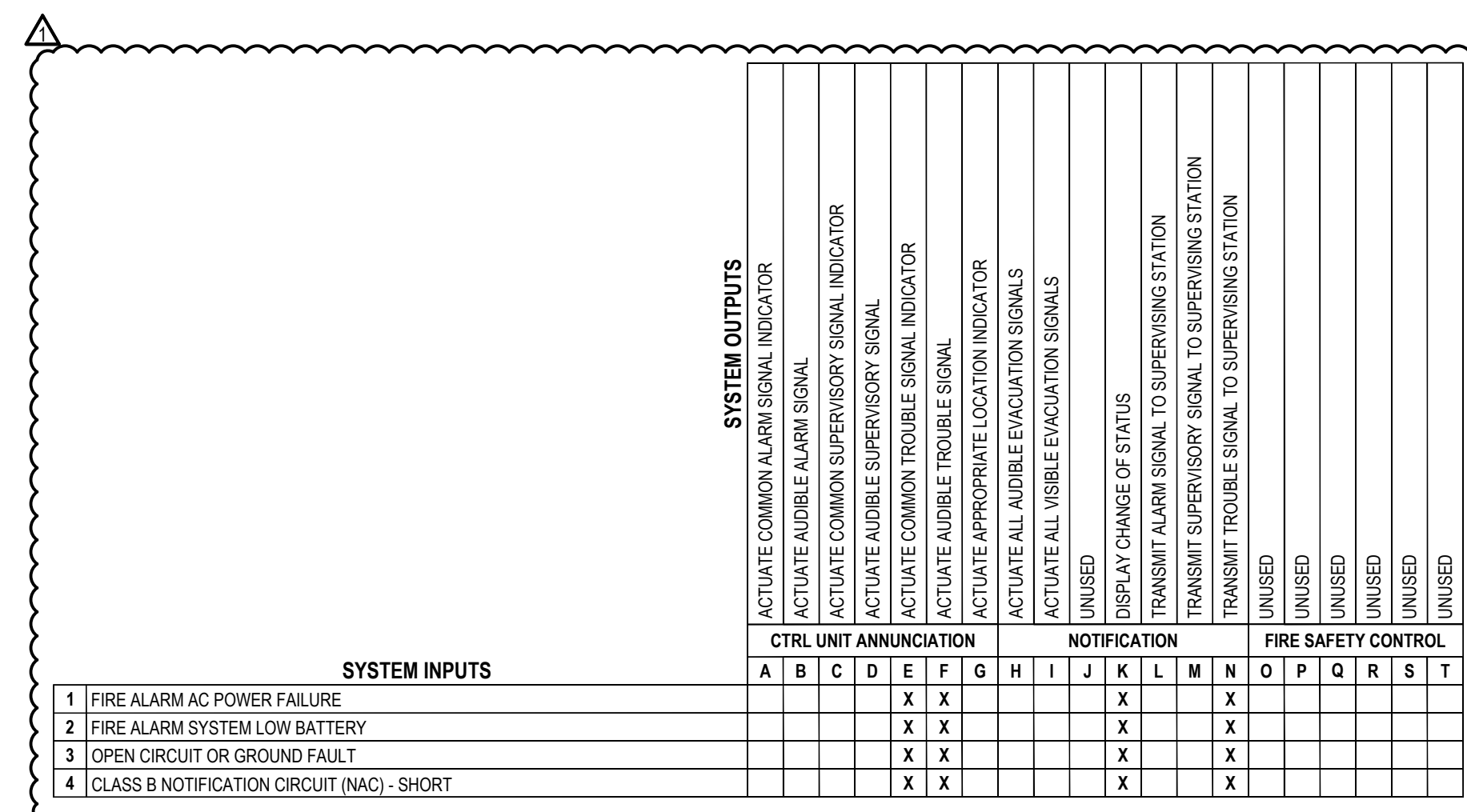

Sheet List Table

Sheet Number	Sheet Title
FA-001	COVER SHEET
FA-101	DEVICE PLACEMENT PLAN
FA-601	CALCULATIONS AND SCHEDULES
FA-701	WIRING TYPICALS

FIRE ALARM SYMBOL LEGEND

SYMBOL	DESCRIPTION	BRAND / MODEL	BACKBOX	WIRE TYPE(S)
NAC#	4009 IDNET NAC EXTENDER PANEL, 120 VAC, BEIGE	4009-9201	SIMPLEX CABINET	
INITIATING DEVICES				
S	SMOKE SENSOR, ADDRESSABLE, PHOTOELECTRIC W/ STANDARD BASE, ADDRESSABLE	4098-9714 HEAD 4098-9792 BASE	4" OCT, 1-1/2" D	M
S	DUCT SMOKE DETECTOR, ADDRESSABLE	4098-9755	MOUNTS TO DUCTWORK	M
	SAMPLING TUBE, 49"	4098-9856		
MODULES AND RELAYS				
RM	DUAL RELAY IAM, ADDRESSABLE	4090-9008	4" SQ, 2-1/8" D W/ COVER	M/R
	#N/A	#N/A		
NOTIFICATION APPLIANCES				
#	STROBE, CONVENTIONAL, WALL MOUNT, MULTI CANDELA, CLEAR LENS, RED, FIRE LETTERING	4906-9101	SINGLE GANG 1-1/2" D	V
#	HORN/STROBE, CONVENTIONAL, WALL MOUNT, MULTI CANDELA, CLEAR LENS, RED, FIRE LETTERING	4906-9127	4" SQ, 1-1/2" D	V
#	HORN/STROBE, CONVENTIONAL, CEILING MOUNT, MULTI CANDELA, CLEAR LENS, RED, FIRE LETTERING	4906-9128	4" SQ, 1-1/2" D	V
MISCELLANEOUS DEVICES				
X	REMOTE TEST STATION W/ LED AND KEY SWITCH	2098-9806	SINGLE GANG 2" D	K

FIRE ALARM WIRE LEGEND

CIRCUIT DESCRIPTION	CONSTRUCTION	GAUGE	CIRCUIT PROPERTIES	ACCEPTABLE CABLE TYPES							
				FFLR	FRP	THIN	TFIN	OUTDOOR*			
K REMOTE TEST SWITCH/LED	(2) 2 COND. SOLID	14 AWG		X	X						
M IDNET	UTP SOLID	18 AWG	0.60µF MAX TOTAL LINE CAPACITANCE	X	X						
R RELAY	2 COND. SOLID	14 AWG		X	X	X	X				
V VISUAL	2 COND. SOLID	14 AWG		X	X						
				CONDUIT SIZE							
				MAX CONDUCTOR AREA		CONDUIT SIZE		MAX CONDUCTOR AREA			
				1/2"		1-1/4"		0.588 SQ INCH*			
				3/4"		1-1/2"		0.814 SQ INCH*			
				1"		2"		1.342 SQ INCH*			
				* 40% CONDUIT FILL PER N.E.C.							
				STP = SHIELDED TWISTED PAIR							
				UTP = UNSHIELDED TWISTED PAIR							
ITEMS SUCH AS CAPACITANCE BETWEEN CONDUCTORS AND WIRE GAUGE CAN BE CRUCIAL TO THE CIRCUIT DESIGN OF THIS SYSTEM INSTALLATION. THE INSTALLING CONTRACTOR IS RESPONSIBLE FOR SELECTING AND INSTALLING CABLE MANUFACTURER AND MODEL THAT MEETS OR EXCEEDS THE ABOVE REQUIREMENTS. RECOMMENDED CABLE MANUFACTURERS AND MODEL NUMBERS ARE AVAILABLE UPON REQUEST.											

GENERAL NOTES

- THESE DRAWINGS DEPICT GENERAL LOCATIONS OF LIFE SAFETY EQUIPMENT & FIELD DEVICES. EXACT ROUTING OF CONDUITS IS TO BE DETERMINED IN THE FIELD BY THE INSTALLING CONTRACTOR TO SUIT CONDITIONS. ALL CHANGES SHALL BE CLEARLY INDICATED ON THE RECORD DRAWINGS.
- SHOULD ANY CONDITIONS EXIST THAT DIFFER FROM WHAT IS INDICATED ON THESE DRAWINGS WHICH CAUSE MAJOR DEVIATIONS IN THE WORK SHOWN, THE CONTRACTOR SHALL CONTACT JOHNSON CONTROLS IN A TIMELY MANNER SO AS NOT TO IMPAIR THE CONSTRUCTION SCHEDULE.
- CONTRACTOR IS RESPONSIBLE FOR MAKING AND OBTAINING APPROVAL FOR ALL NECESSARY ADJUSTMENTS IN CIRCUITING AS REQUIRED TO ACCOMMODATE THE RELOCATION OF EQUIPMENT AND/OR DEVICES WHICH ARE AFFECTED BY ANY AUTHORIZED CHANGE. ALL CHANGES SHALL BE CLEARLY INDICATED ON THE RECORD DRAWINGS. A STAMPED SET OF APPROVED FIRE ALARM DRAWINGS SHALL BE AT THE JOB SITE AND SHALL BE USED FOR INSTALLATION.
- THE POWER CIRCUIT TO THE FACP AND TO THE FIRE ALARM POWER SUPPLIES SHALL BE ON A DEDICATED 120V, 20A BRANCH CIRCUIT BREAKER, AND SHALL HAVE A RED MARKING, LOCK-ON PROVISION AND SHALL BE IDENTIFIED AS "FIRE ALARM CIRCUIT CONTROL." THE LOCATION OF THE CIRCUIT DISCONNECT MEANS (CIRCUIT BREAKER) SHALL BE PERMANENTLY IDENTIFIED AT THE FIRE ALARM CONTROL UNIT.
- UPDATE THE AS-BUILT DRAWING SET DAILY WITH JOB PROGRESS. RETURN THE AS-BUILT DRAWING SET TO JOHNSON CONTROLS NO LATER THAN 7 DAYS AFTER FINAL TEST.
- THE CONTRACTOR WILL MAINTAIN ALL AREAS OF THE BUILDING IN A NEAT AND WORKMANLIKE MANNER.
- DO NOT APPLY POWER EXCEPT IN THE PRESENCE OF A FACTORY TRAINED JOHNSON CONTROLS TECHNICAL REPRESENTATIVE.
- ANY SMOKE DETECTOR HEAD INSTALLED BEFORE THE BUILDING IS CLEANED AND ACCEPTED SHALL BE COVERED TO PROTECT FROM DUST. ANY FALSE ALARMS DUE TO DIRT CONTAMINATED HEADS SHALL BE THE RESPONSIBILITY OF THE FIRE ALARM INSTALLER.
- THE FIRE ALARM INSTALLER WILL MAINTAIN THE FIRE RESISTANCE INTEGRITY OF ALL WALL, CEILING, AND ROOF ASSEMBLIES ANY TIME THAT WORK IS NOT ACTIVELY BEING PERFORMED.
- INSTALLATION OF DEVICES SHALL BE IN ACCORDANCE WITH MANUFACTURER'S INSTRUCTIONS. POWER LIMITED AND NON-POWER LIMITED FIELD WIRING MUST BE INSTALLED WITHIN THE FACP ENCLOSURE IN ACCORDANCE WITH MANUFACTURER'S INSTRUCTIONS AND APPLICABLE ELECTRICAL CODES. REFER TO "APPLICABLE CODES & STANDARDS" FOR SPECIFIC CODE REFERENCES.
- ALL WIRING SHALL BE INSTALLED ACCORDING TO APPLICABLE ELECTRICAL CODES.
- FIRE ALARM CIRCUITS SHALL BE IDENTIFIED IN ACCORDANCE WITH APPLICABLE ELECTRICAL CODES. MARK ALL FIRE ALARM WIRES IN ACCORDANCE WITH APPLICABLE ELECTRICAL CODE SECTIONS FOR POWER LIMITED AND NON-POWER LIMITED WIRE.
- FIRE ALARM CABLE INSTALLED IN DUCTS, PLENUM, AND OTHER SPACES USED FOR ENVIRONMENTAL AIR SHALL BE TYPE FFLP.
- FIRE ALARM CABLE INSTALLED IN THE VERTICAL RUNS AND PENETRATING MORE THAN ONE FLOOR OR CABLES INSTALLED IN VERTICAL RUNS IN SHAFTS SHALL BE TYPE FFLR.
- FIRE ALARM CABLE INSTALLED IN UNDERGROUND CONDUIT OR OTHER WET LOCATIONS SHALL BE UL LISTED FOR WET LOCATIONS.
- FIRE ALARM CIRCUITS EXTENDING BEYOND ONE BUILDING AND RUN OUTDOORS SHALL BE INSTALLED IN ACCORDANCE WITH APPLICABLE ELECTRICAL CODES, WHERE APPLICABLE.
- ALL WIRING, INCLUDING SHIELDS MUST BE DRY AND FREE OF SHORTS AND GROUNDS.
- ALL SHIELDED WIRE MUST HAVE SHIELD CONTINUITY AT FULL LENGTH OF THE WIRE.
- ONLY SYSTEM WIRING CAN BE RUN IN THE SAME CONDUIT.
- 120VAC IS NOT PERMITTED IN THE SAME CONDUIT WITH LOW VOLTAGE WIRING.
- MAINTAIN MAXIMUM CONDUIT FILL RATIO AS PER APPLICABLE ELECTRICAL CODES REQUIREMENTS.
- EXISTING CONDUITS MAY BE USED BY THE INSTALLATION CONTRACTOR AS DEEMED NECESSARY; HOWEVER, ANY EXISTING CONDUIT WILL BE USED ONLY IF CONDUITS MEET CURRENT STANDARDS AND CODES. JOHNSON CONTROLS MAKES NO STATEMENTS WRITTEN OR VERBAL AS TO THE CONDITION OF EXISTING CONDUITS.

IMPORTANT NOTICE TO USER: This information may not be sold or transferred to any third party, used on other projects or additions to the project for which it was prepared, or used for completion of this project by any third party. Johnson Controls disclaims all liability for the use or reuse of altered files by the user or any third party and such use will be a user's sole risk. User shall, to the fullest extent permitted by law, defend, indemnify, and hold Johnson Controls harmless from any and all claims for loss, damage or injury arising directly or indirectly from any such unauthorized use.

HARNETT COUNTY DSS UPFIT 2ND FLOOR

HARNETT COUNTY DSS
311 W CORNELIUS HARNETT B
LILLINGTON, NC 27546

ISSUE LOG	MARK	DATE	CD	CHK	DESCRIPTION
	L	08/07/24	TP	JS	REVISED PER REVIEW COMMENTS

REVISION 1

DRAWN BY: T PALCZUK
CHECKED BY: J SIMMONS
ISSUE DATE: 7/23/24
JOB #: 250581495
PROJECT #: 24-650581495
JOHNSON CONTROLS © 2024

SYSTEM: FIRE ALARM SYSTEM

SHEET:

COVER SHEET

FA-001

**HARNETT COUNTY DSS
 UPFIT 2ND FLOOR**
 HARNETT COUNTY DSS
 311 W CORNELIUS HARNETT B
 LILLINGTON, NC 27546

ISSUE NO.	DATE	CD	CHK	DESCRIPTION
MARK	08/07/24	TP	JS	REVISED PER REVIEW COMMENTS

REVISION 1

DRAWN BY:	T PALCZUK
CHECKED BY:	J SIMMONS
ISSUE DATE:	7/23/24
JOB #:	250581495
PROJECT #:	24-650581495
JOHNSON CONTROLS © 2024	

**SYSTEM:
 FIRE ALARM SYSTEM**

SHEET:

**CALCULATIONS AND
 SCHEDULES**

FA-601

4100es FACP						
Module	Qty	Description	Standby Current	Total Standby	Alarm Current	Total Alarm
Panel Equipment						
4100-9701	1	ES PS Master Controller - English	0.2770	0.2770	0.3210	0.3210
4100-2300	1	EXPANSION BAY (PHASE 10 ONLY)	0.0000	0.0000	0.0000	0.0000
4100-2504	1	CONNECTED SERVICES GATEWAY WITH IP COMMUNICATOR - SIDE MOUNT	0.1250	0.1250	0.1250	0.1250
4100-6104	1	ES NET SLOT MOUNT NETWORK INTERFACE CARD	0.1200	0.1200	0.1200	0.1200
4100-6307	1	ES NET DUAL CHANNEL DSL MEDIA CARD	0.1350	0.1350	0.1350	0.1350
4100-5450	1	NAC Card	0.0660	0.0660	0.0660	0.0660
4100-0644	1	120 VAC PDM HARNESS	0.0000	0.0000	0.0000	0.0000
4100-0634	1	POWER DISTRIBUTION MODULE 120V	0.0000	0.0000	0.0000	0.0000
4100-1294	1	LED/SWITCH SLIDE-IN LABEL KIT	0.0000	0.0000	0.0000	0.0000
4100-5131	1	ES-PS Fan Module	0.0000	0.0000	0.2000	0.2000
4100-1284	1	8 SW, 16 RED/GREEN LED MODULE	0.0000	0.0000	0.0240	0.0240
4100-3209	1	8-POINT 3A RELAY CARD WITH FEEDBACK	0.0160	0.0160	0.2000	0.2000
4100-1288	1	64/64 LED/SWITCH CONTROLLER	0.0200	0.0200	0.2120	0.2120
4100-1279	1	2" BLANK DISPLAY MODULE	0.0000	0.0000	0.0000	0.0000
Panel Totals			0.7590		1.4030	
IDNet Addressable Devices (SLC)						
4009-9201	1	4009 IDNET NAC EXTENDER, 120 VAC *				
4090-9002	4	IDNET RELAY IAM *				
4090-9008	1	ADDRESSABLE DUAL CONTACT RELAY IAM *				
4098-9714	40	TRUEALARM PHOTO SMOKE SENSOR				
4098-9733	5	TRUEALARM HEAT SENSOR				
4098-9755	5	TRUEALARM DUCT SMOKE SENSOR W/O RELAY OUTPUT *				
4098-9792	45	TRUEALARM SENSOR BASE *				
4099-9006	5	ADDRESSABLE DOUBLE ACTION MANUAL STATION, PUSH *				
Address Totals			61 Addresses	0.0488		0.0610
System Totals*:			Standby	0.8078	Alarm	1.4640

* Device Address current draw included below (See Additional Current Draws):
 IDNet cards include 40mA alarm current for 20 device LEDs in alarm in addition to base current listed on datasheet.
 1. Base FACP includes current draw for all included components. See data sheet for details.

Battery Set #1 (Cabinet/Charger #1)						
Module	Qty	Description	Standby Current	Total Standby	Alarm Current	Total Alarm
Select ALL Power Supplies on this battery set:						
ESPS-1			0.7590	0.7590		1.4030
Sub Total			0.7590			1.4030
Additional Current Draws:						
IDNac Current Boost for 29vdc Regulated Output **						
RUI Connected Peripheral Devices	0	x 0.0035	= 0.0000	x 0.0035	= 0.0000	
MAPNET/IDNet Device Address Communication Current	61	x 0.000800	= 0.0488	x 0.001000	= 0.0610	
Sub Total			0.8078			1.4640
Spare addressable point capacity						
Spare addressable point capacity	0%	0	x 0.0008	= 0.0000	x 0.001	= 0.0000
Total			0.8078			1.4640
Standby Time = 24 Hrs						
Standby Time = 24 Hrs			x 0.8078	= 19.3872	Standby Ah	
Alarm Time = 5 Min						
Alarm Time = 5 Min			0.08333 x 1.464	= 0.1220	Alarm Ah	
Additional Spare Battery Capacity = 0%				+ 0.0000		
				+ 19.5092		
Battery Discharge Factor = 20%				+ 3.9018		
Minimum Battery Required 2081-9287 25AH (2x)				23.4110		
Battery Supplied 2081-9287 25AH (2x)						

* System Totals represent total system current requirements. Those currents may be distributed between multiple battery sets or power supplies as shown above.

** IDNac Current Boost formula: ((29.5 * IDNac Alarm Current) / 92) / 20.4 = Adjusted Current
 DC-DC Converter Output = 29.5vdc. Terminal Output is 29vdc due to 0.5vdc internal loss.
 Converter Worst Case efficiency is 92%, 20.4vdc represents battery output in 85% depleted state

NAC 1 4009 NAC						
Module	Qty	Description	Standby Current	Total Standby	Alarm Current	Total Alarm
Panel Equipment						
4009-9201	1	4009 IDNET NAC EXTENDER, 120 VAC	0.8850	0.8850	0.1850	0.1850
Panel Totals			0.8850		0.1850	
Notification Appliances						
Setting						
4606-9101	3	REMOTE LCD ANNUNCIATOR	15	0.0650	0.1950	0.1400
4906-9127	3	A/V MC NON-ADDRESS, RED, WALL	15	0.0000	0.0000	0.0750
4906-9128	1	A/V MC NON-ADDRESS, RED CEILING	30	0.0000	0.0000	0.1320
4906-9128	2	A/V MC NON-ADDRESS, RED CEILING	75	0.0000	0.0000	0.2500
Peripheral Totals				0.1950		1.2770
System Totals*:			Standby	0.2800	Alarm	1.4620

Battery Set #1 (Cabinet/Charger #1)						
Module	Qty	Description	Standby Current	Total Standby	Alarm Current	Total Alarm
Select ALL Power Supplies on this battery set:						
4009			0.2800	0.2800		1.4620
Sub Total			0.2800			1.4620
Additional Current Draws:						
RUI Connected Peripheral Devices	0	x 0.0035	= 0.0000	x 0.0035	= 0.0000	
MAPNET/IDNet Device Address Communication Current	0	x 0.000000	= 0.0000	x 0.000000	= 0.0000	
Sub Total			0.2800			1.4620
Spare addressable point capacity						
Spare addressable point capacity	0%	0	x 0	= 0.0000	x 0	= 0.0000
Total			0.2800			1.4620
Standby Time = 24 Hrs						
Standby Time = 24 Hrs			x 0.2800	= 6.7200	Standby Ah	
Alarm Time = 5 Min						
Alarm Time = 5 Min			0.08333 x 1.462	= 0.1218	Alarm Ah	
Additional Spare Battery Capacity = 0%				+ 0.0000		
				+ 6.8418		
Battery Discharge Factor = 20%				+ 1.3684		
Minimum Battery Required 2081-9274 10AH (2x)				8.2102		
Battery Supplied 2081-9274 10AH (2x)						

* System Totals represent total system current requirements. Those currents may be distributed between multiple battery sets or power supplies as shown above.

NAC 1 4009 NAC VOLTAGE DROPS												
WIRE RESISTANCE BASED ON TABLE 8 FROM NATIONAL ELECTRICAL CODE (UNCOATED SOLID COPPER WIRE) @ 75 Celsius												
NOTIFICATION CIRCUIT DESCRIPTION	Power Supply	Panel Circuit	Plan Ckt.	Dist. (D) Feet	Wire Gauge	Wire Res. / Ft. (R)	Total Alarm (A)	V. Drop (A^2D^3/R)	Volt @ End	% Volt Drop	Min Device Voltage	PID Setting
												Device Type
												4606-9101
												15cd
												MC A/V
												30cd
												MC CEIL A/V
												75cd
												MC CEIL A/V
												0.0000
												0.0000
												0.1320
												0.2500
2ND FLOOR	4009	SIG1	V3	300	14ga	0.0031	1.277	2.352	17.148	12.06%	16vdc	446 Ft.
												3
												3
												1
												2

NOTE:
 LUMP SUM METHOD WAS USED TO CALCULATE ALLOWABLE VOLTAGE DROP. THIS METHOD ALLOWS FOR A SMALL MARGIN OF SAFETY, TAKING INTO CONSIDERATION THAT THE ACTUAL INSTALLED CIRCUIT ROUTING MAY DIFFER FROM WHAT IS SHOWN ON THE SHOP DRAWINGS. IF THE ACTUAL CIRCUIT LENGTH IS GOING TO EXCEED THE MAXIMUM ALLOWABLE CIRCUIT LENGTH, CONTACT YOUR LOCAL JOHNSON CONTROLS DISTRICT OFFICE.

NAC EXTENDER PANEL WIRING

SIMPLEX 4009 SERIES

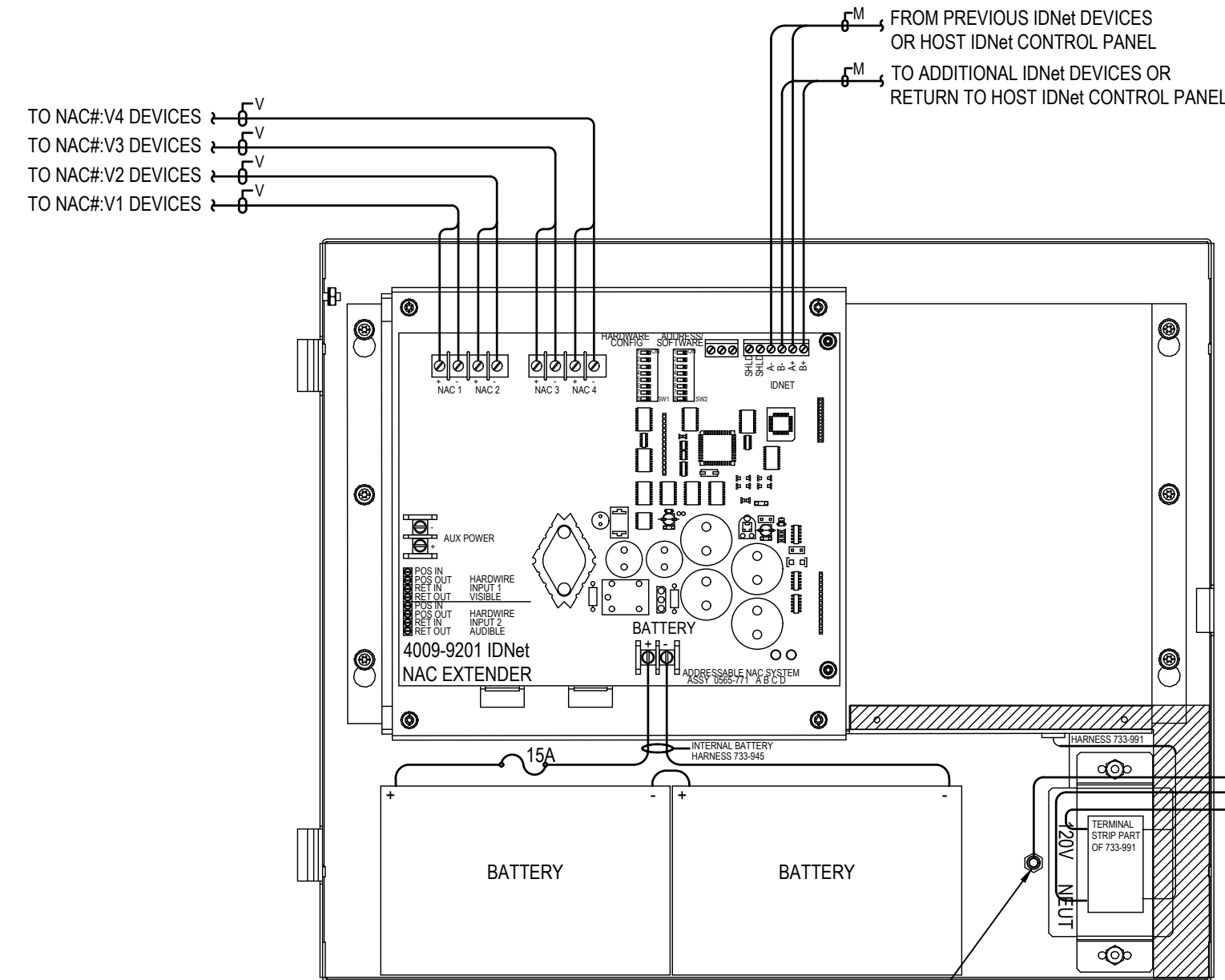

IDNET CONTROL WIRING NOTES

IF OPTIONAL SHIELDS ARE USED FOR IDNET WIRING, FOLLOW THESE PRECAUTIONS:

- IF IDNET WIRING CONTINUES ON TO ANOTHER DEVICE, TAPE SHIELDS TOGETHER.
- IF IDNET WIRING TERMINATES AT THE 4009 IDNET NAC EXTENDER, TAPE SHIELD.
- NEVER TERMINATE SHIELDS AT THE 4009 IDNET NAC EXTENDER.

STANDARD SENSOR BASE

SIMPLEX 4098-9792

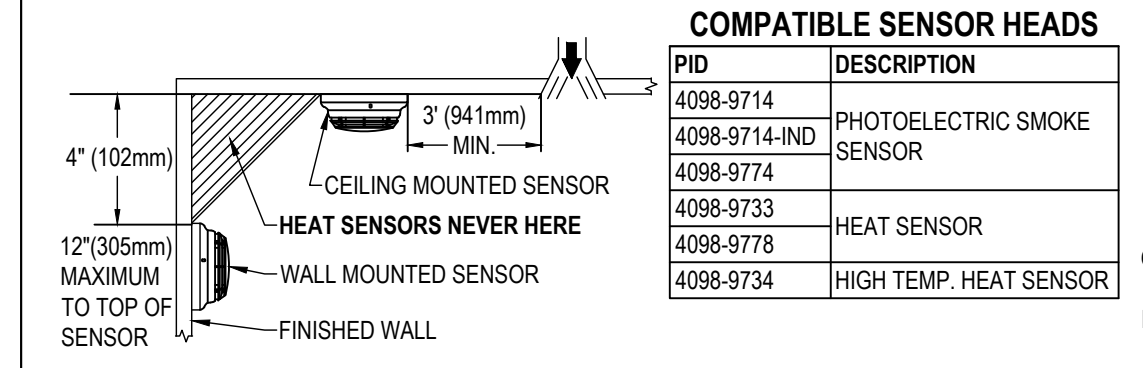

PID	DESCRIPTION
4098-9714	PHOTOELECTRIC SMOKE SENSOR
4098-9714-IND	SENSOR
4098-9774	HEAT SENSOR
4098-9773	HEAT SENSOR
4098-9778	HEAT SENSOR
4098-9734	HIGH TEMP. HEAT SENSOR

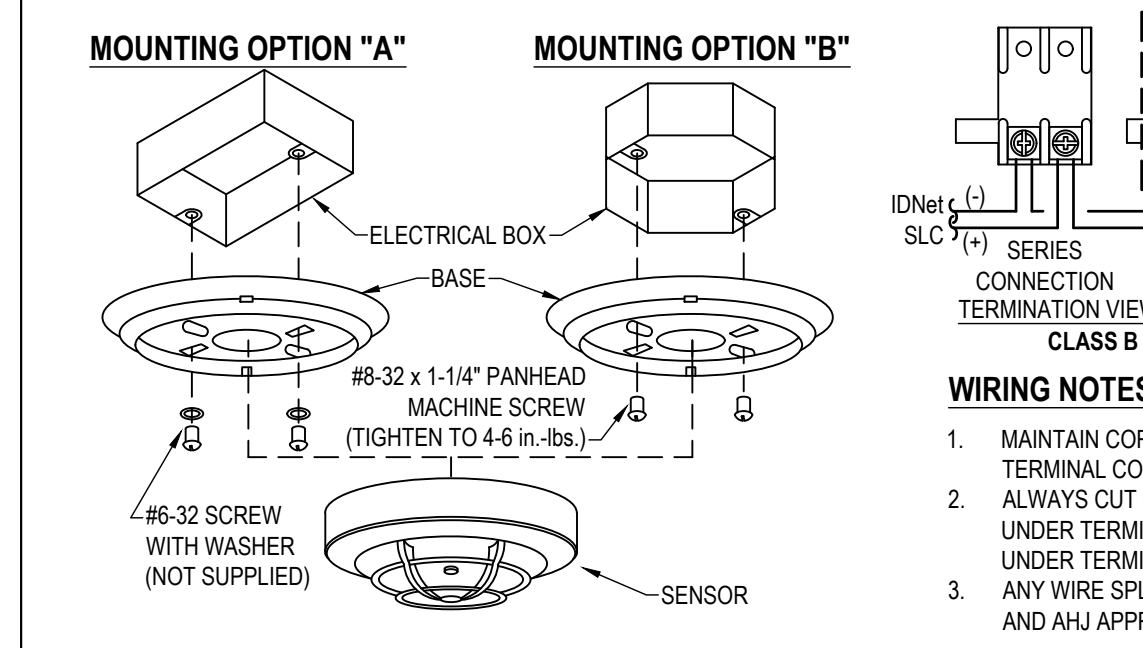

WIRING NOTES

- MAINTAIN CORRECT POLARITY ON TERMINAL CONNECTIONS.
- ALWAYS CUT CONDUCTORS AND SECURE UNDER TERMINALS. NEVER LOOP WIRES UNDER TERMINALS.
- ANY WIRE SPLICES TO BE MADE BY LISTED AND AHJ APPROVED METHODS.

MOUNTING OPTIONS

OPTION	DESCRIPTION	NOTE
A	SINGLE GANG BOX, 2-1/8" (54mm) DEEP - FLUSH MOUNT	BY OTHERS
B	4" (102mm) OCTAGONAL BOX, 1-1/2" (38mm) DEEP, MINIMUM - FLUSH MOUNT	BY OTHERS
C	4" (102mm) SQUARE BOX, 1-1/2" DEEP (MIN) W/ SIMPLEX 4098-9832 ADAPTER KIT	BOX BY OTHERS, 4098-9832 ORDERED SEPARATELY
D	4" (102mm) SQUARE BOX, 1-1/2" DEEP (MIN) W/ SINGLE GANG COVER PLATE 3/4" (19mm) EXTENSION	BY OTHERS

1. FOR ADDITIONAL MOUNTING OPTIONS, DOWNLOAD DATA SHEET 4098-0019 FROM HTTP://WWW.SIMPLEX-FIRE.COM

DUCT SMOKE DETECTOR

SIMPLEX 4098-9755 ANALOG 2-WIRE DUCT SENSOR

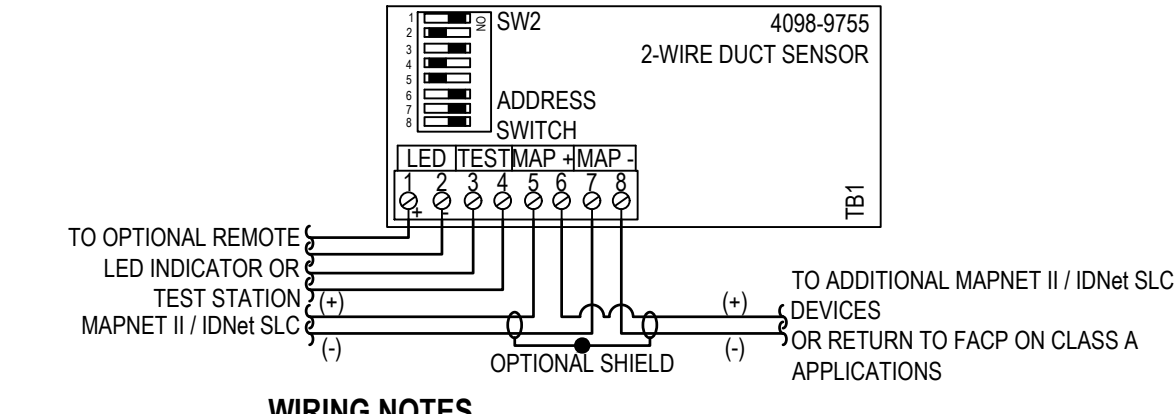
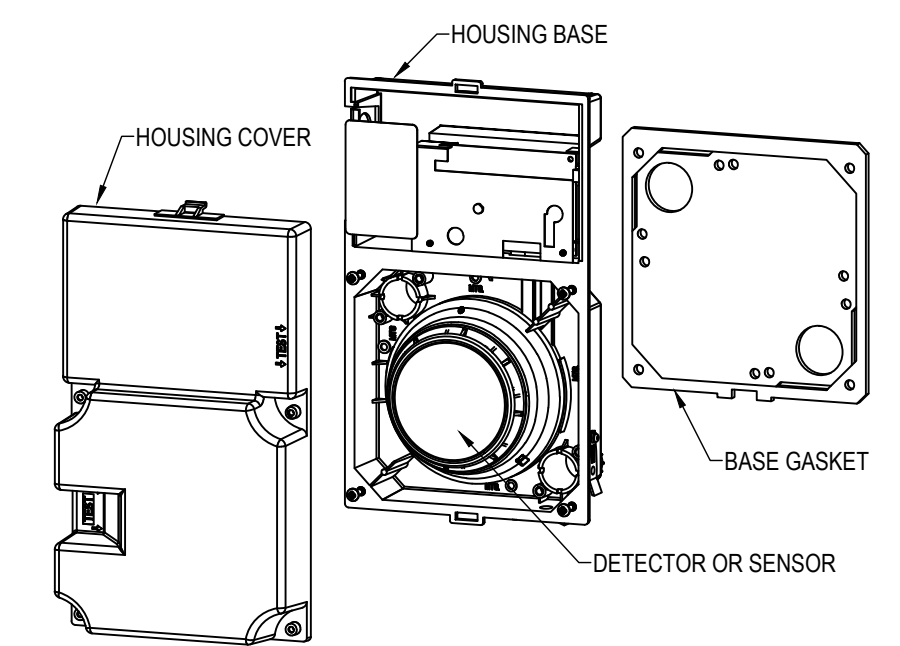

WIRING NOTES

- MAINTAIN CORRECT POLARITY ON TERMINAL CONNECTIONS.
- ALWAYS CUT CONDUCTORS AND SECURE UNDER TERMINALS. NEVER LOOP WIRES UNDER TERMINALS.
- ANY WIRE SPLICES TO BE MADE BY LISTED AND AHJ APPROVED METHODS. CLASS B APPLICATIONS ONLY.

DUAL CONTACT RELAY IAM

SIMPLEX 4090-9008

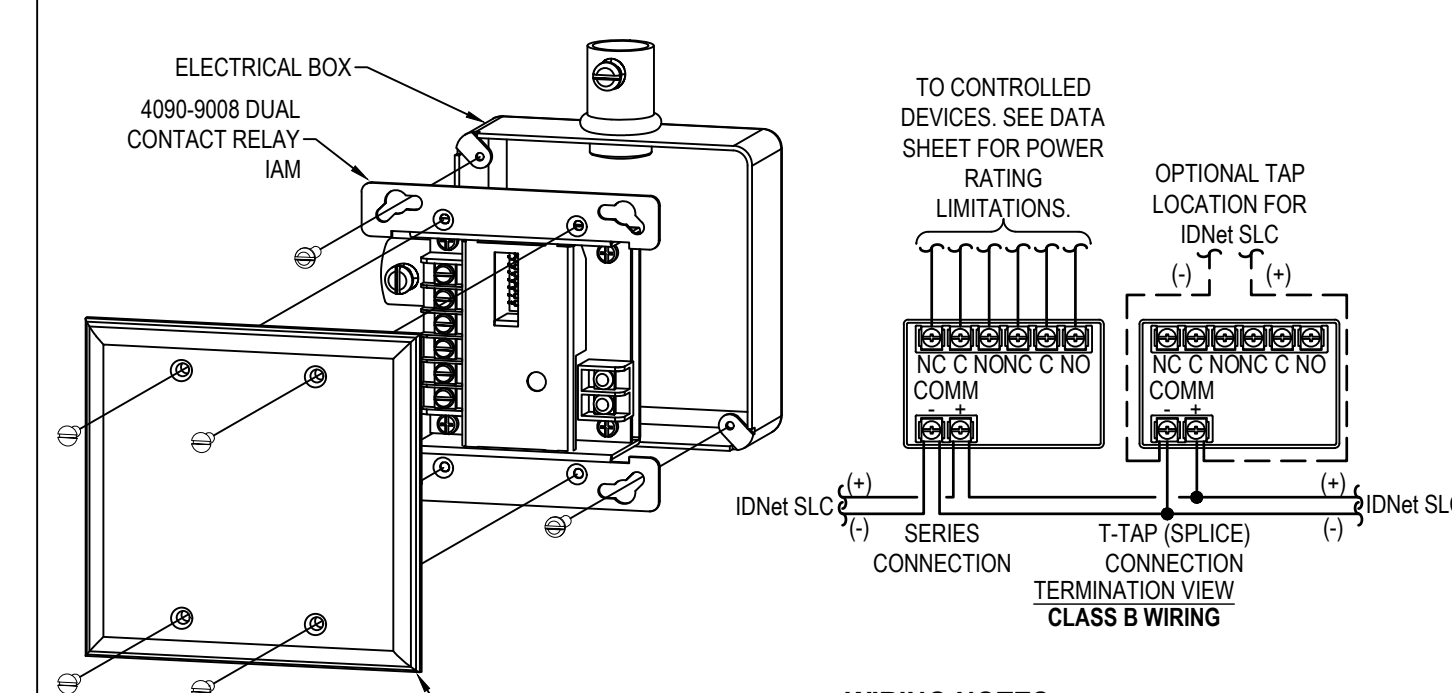

WIRING NOTES

- MAINTAIN CORRECT POLARITY ON TERMINAL CONNECTIONS.
- ALWAYS CUT CONDUCTORS AND SECURE UNDER TERMINALS. NEVER LOOP WIRES UNDER TERMINALS.
- ANY WIRE SPLICES TO BE MADE BY LISTED AND AHJ APPROVED METHODS (CLASS B ONLY).

MOUNTING OPTIONS

OPTION	DESCRIPTION	NOTE
A	4" (102mm) SQUARE BOX, 2-1/8" MINIMUM DEPTH WITH DOUBLE GANG COVER PLATE	BY OTHERS
B	4" (102mm) SQUARE BOX, 2-1/8" MINIMUM DEPTH WITH SIMPLEX 4090-9801 TRIM PLATE FOR SEMI-FLUSH MOUNTED BOX	BOX BY OTHERS, PLATES ORDERED SEPARATELY
C	4" (102mm) SQUARE BOX, 2-1/8" MINIMUM DEPTH WITH SIMPLEX 4090-9802 TRIM PLATE FOR SURFACE MOUNTED BOX	BOX BY OTHERS, PLATES ORDERED SEPARATELY

1. FOR ADDITIONAL MOUNTING OPTIONS, DOWNLOAD DATA SHEET S4090-0014 FROM HTTP://WWW.SIMPLEX-FIRE.COM

TrueAlert CONVENTIONAL APPLIANCES

SIMPLEX 4906 SERIES WALL MOUNTED VISUAL

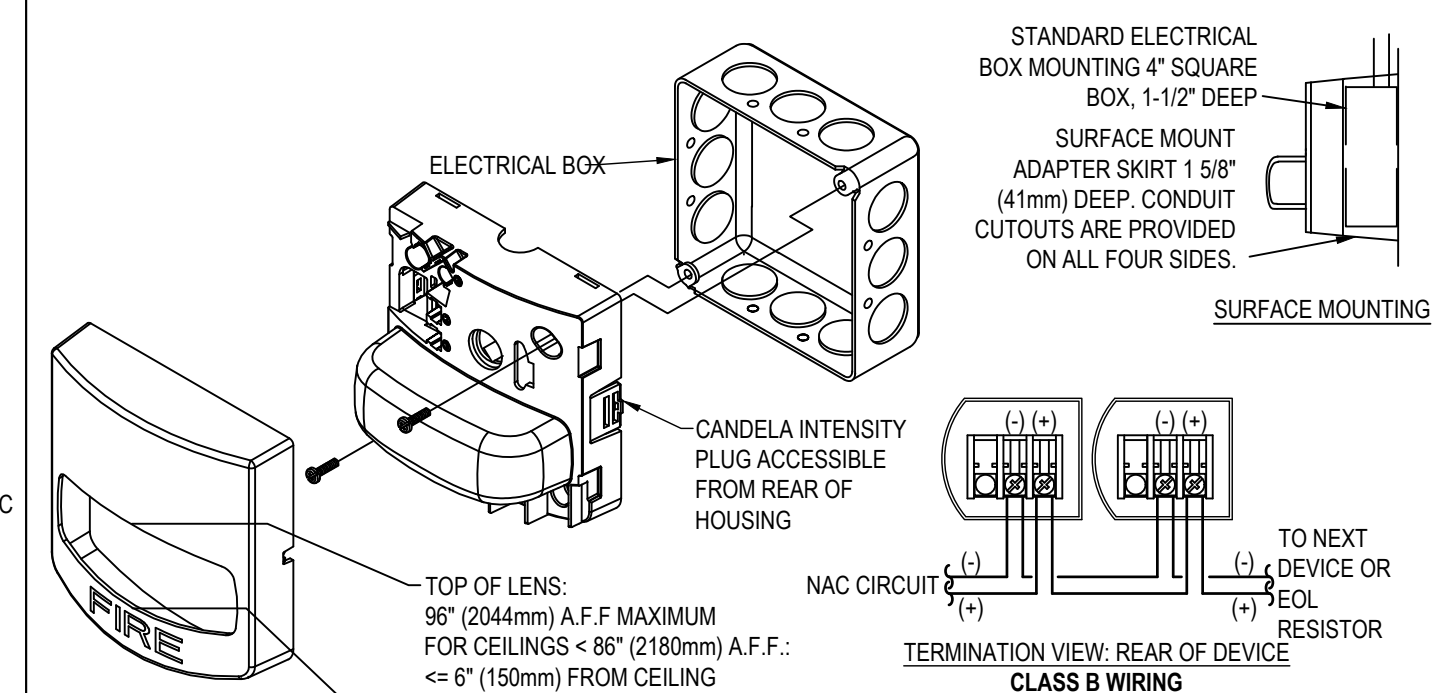

WIRING NOTES

- MAINTAIN CORRECT POLARITY ON TERMINAL CONNECTIONS.
- ALWAYS CUT CONDUCTORS AND SECURE UNDER TERMINALS. NEVER LOOP WIRES UNDER TERMINALS.
- ANY WIRE SPLICES TO BE MADE BY LISTED AND AHJ APPROVED METHODS.

MOUNTING OPTIONS

OPTION	DESCRIPTION	NOTE
A	SINGLE GANG BOX, 1-1/2" (64mm) DEEP	BY OTHERS. WHEN SURFACE MOUNTING USE 4905-9937 (RED) OR 4906-9940 (WHITE) SKIRT
B	4" (102mm) SQUARE BOX, 1-1/2" (38mm) DEEP, MINIMUM	BY OTHERS, WHEN SURFACE MOUNTING USE 4905-9937 (RED) OR 4906-9940 (WHITE) SKIRT
C	Z GANG BOX, 1-1/2" (38mm) DEEP	ORDERED SEPARATELY
D	SIMPLEX 2975-9145, 7-7/8" x 5-1/8" x 2-3/4" (127mm x 98mm x 56mm) REQUIRES 4905-9931 PLATE	ORDERED SEPARATELY

1. FOR ADDITIONAL MOUNTING OPTIONS, DOWNLOAD DATA SHEET 4906-0002 FROM HTTP://WWW.SIMPLEX-FIRE.COM

TrueAlert CONVENTIONAL APPLIANCES

SIMPLEX 4906 SERIES WALL MOUNTED MULTI-CANDELA AUDIBLE / VISUAL

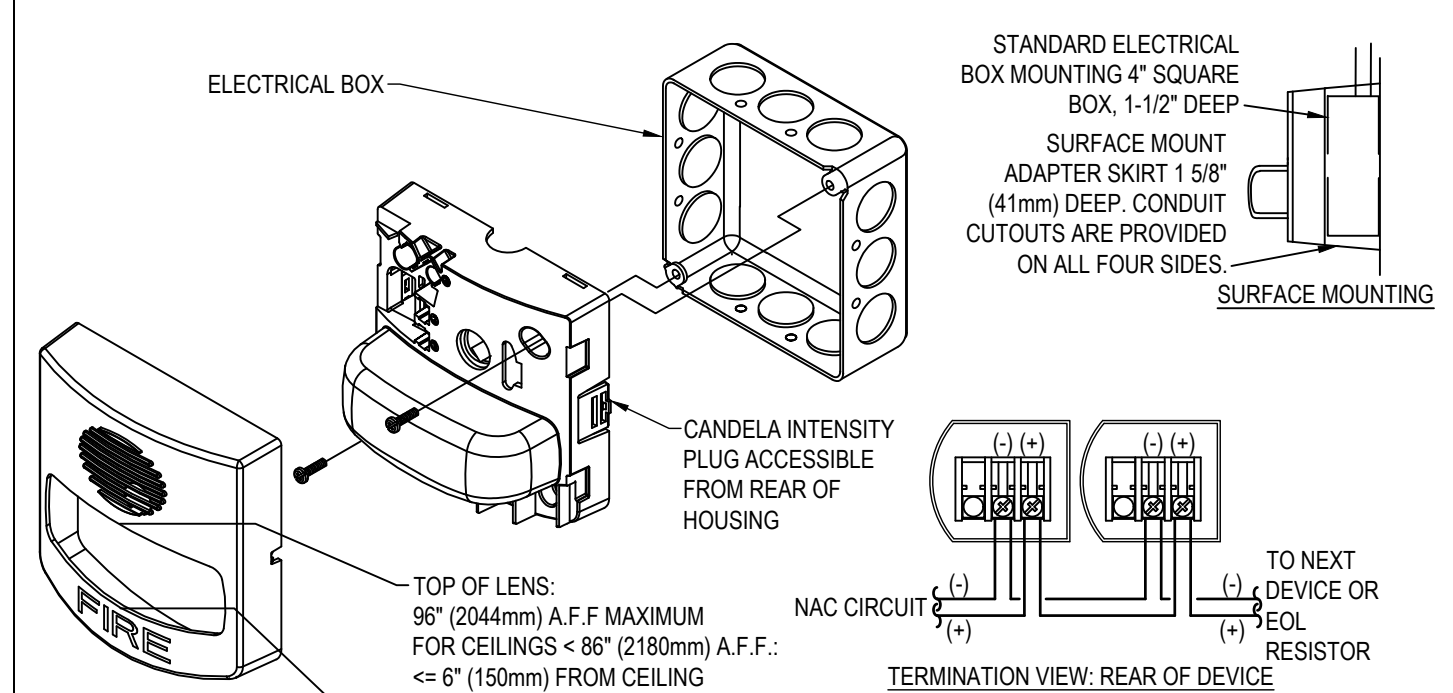

WIRING NOTES

- MAINTAIN CORRECT POLARITY ON TERMINAL CONNECTIONS.
- ALWAYS CUT CONDUCTORS AND SECURE UNDER TERMINALS. NEVER LOOP WIRES UNDER TERMINALS.
- ANY WIRE SPLICES TO BE MADE BY LISTED AND AHJ APPROVED METHODS.

MOUNTING OPTIONS

OPTION	DESCRIPTION	NOTE
A	SINGLE GANG BOX, 1-1/2" (64mm) DEEP	BY OTHERS. WHEN SURFACE MOUNTING USE 4905-9937 (RED) OR 4906-9940 (WHITE) SKIRT
B	4" (102mm) SQUARE BOX, 1-1/2" (38mm) DEEP, MINIMUM	BY OTHERS. WHEN SURFACE MOUNTING USE 4905-9937 (RED) OR 4906-9940 (WHITE) SKIRT
C	Z GANG BOX, 1-1/2" (38mm) DEEP	ORDERED SEPARATELY
D	SIMPLEX 2975-9145, 7-7/8" x 5-1/8" x 2-3/4" (127mm x 98mm x 56mm) REQUIRES 4905-9931 PLATE	ORDERED SEPARATELY

1. FOR ADDITIONAL MOUNTING OPTIONS, DOWNLOAD DATA SHEET 4906-0002 FROM HTTP://WWW.SIMPLEX-FIRE.COM

TrueAlert CONVENTIONAL APPLIANCES

SIMPLEX 4906 SERIES CEILING MOUNTED AUDIBLE / VISUAL

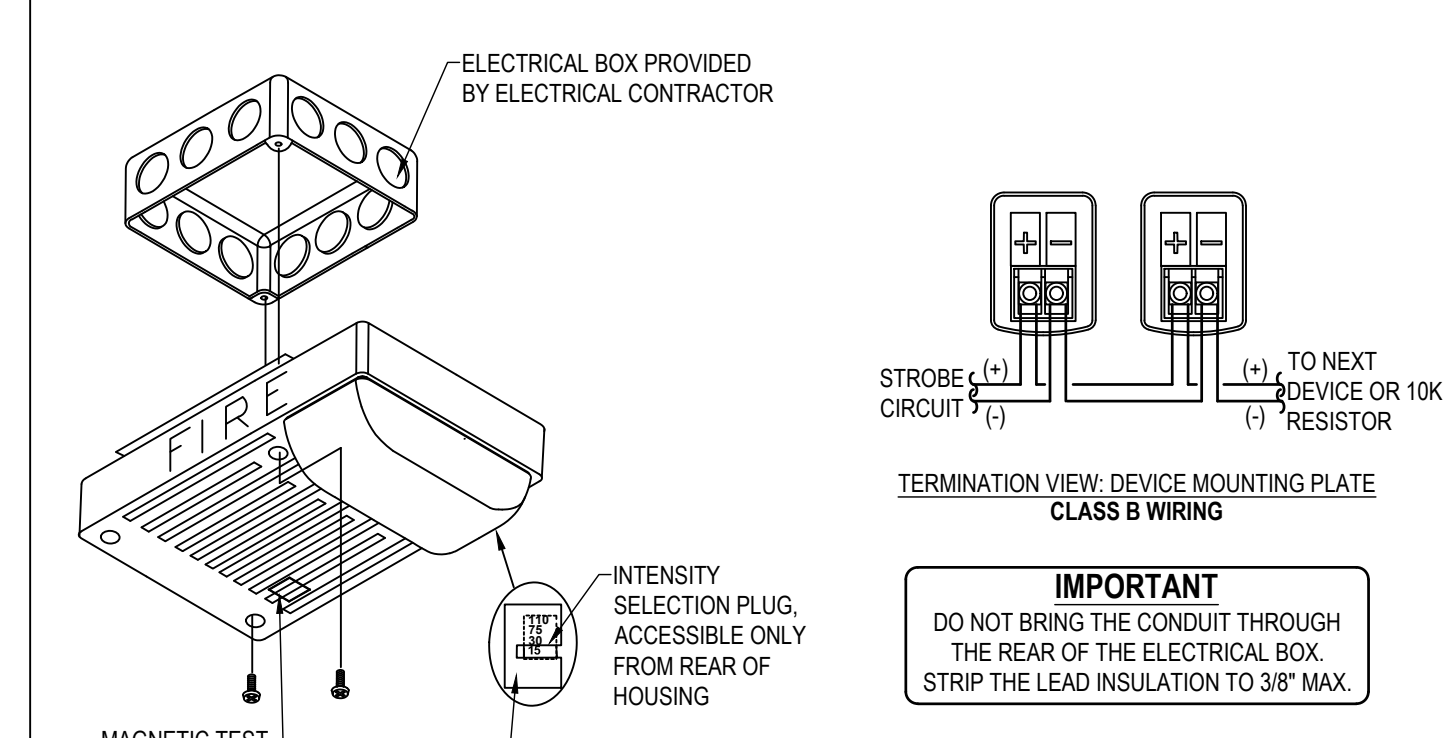

WIRING NOTES

- MAINTAIN CORRECT POLARITY ON TERMINAL CONNECTIONS.
- ALWAYS CUT CONDUCTORS AND SECURE UNDER TERMINALS. NEVER LOOP WIRES UNDER TERMINALS.
- ANY WIRE SPLICES TO BE MADE BY LISTED AND AHJ APPROVED METHODS.

MOUNTING OPTIONS

OPTION	DESCRIPTION	NOTE
A	4" (102mm) SQUARE BOX, 1-1/2" (38mm) DEEP, MINIMUM	BY OTHERS
B	SURFACE MOUNT 4" (102mm) SQUARE BOX, 1-1/2" (38mm) DEEP, MINIMUM	4905-9915 (WHITE) OR 4905-9916 (RED) ADAPTER RECOMMENDED, ORDERED SEPARATELY

1. FOR ADDITIONAL MOUNTING OPTIONS, DOWNLOAD DATA SHEET 4906-0002 FROM HTTP://WWW.SIMPLEX-FIRE.COM
2. 4905-9928 ADAPTER PLATE REQUIRED WITH OPTIONAL 4905-9927 RED WIRE GUARD

REMOTE ALARM INDICATOR / KEY SWITCH

SIMPLEX 2098-9806

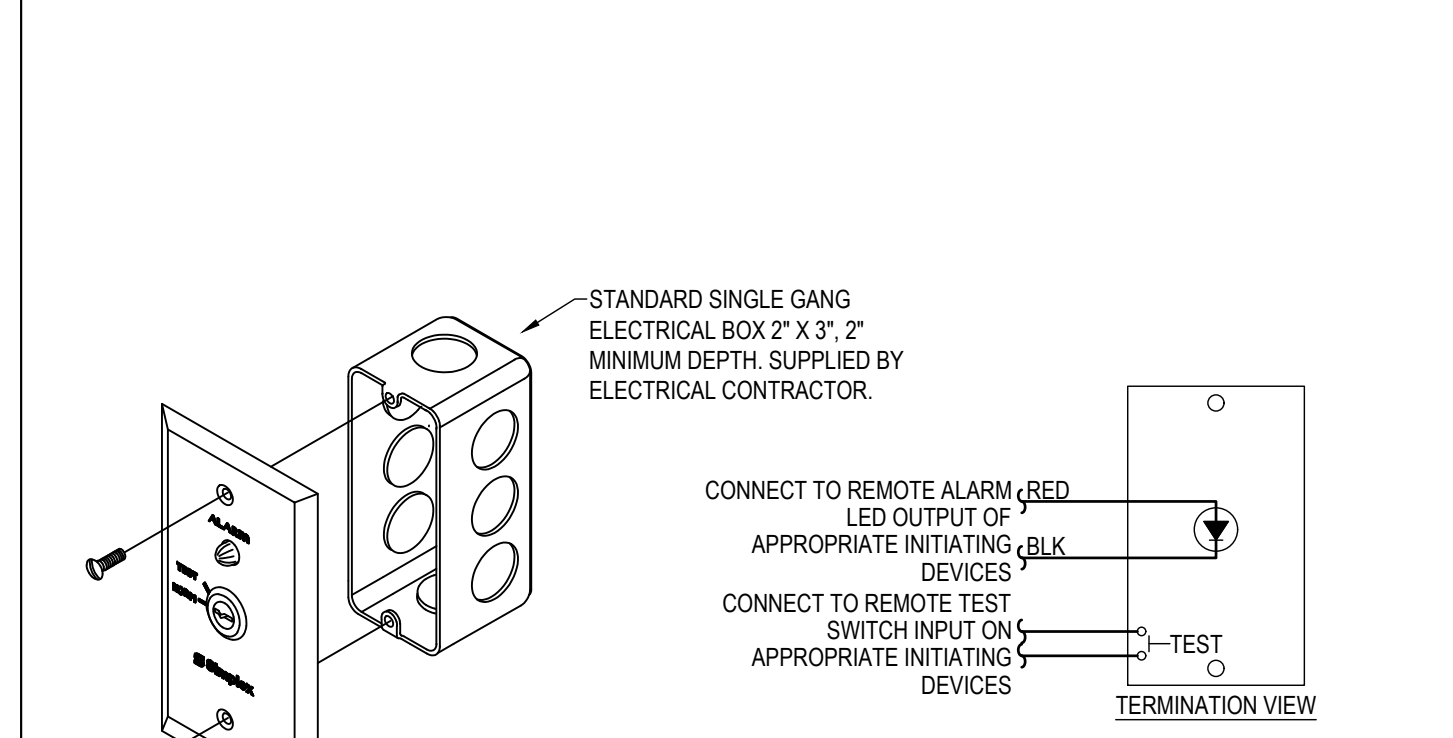

WIRING NOTES

- MAINTAIN CORRECT POLARITY ON TERMINAL CONNECTIONS.
- ALWAYS CUT CONDUCTORS AND SECURE UNDER TERMINALS. NEVER LOOP WIRES UNDER TERMINALS.
- ONE INDICATOR MAY BE INSTALLED PER DETECTOR.

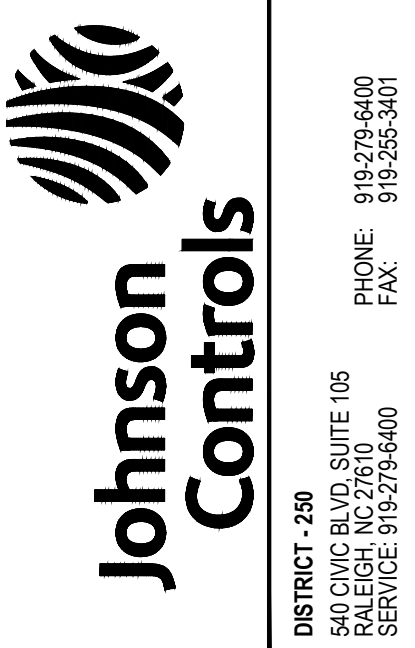

DISTRICT - 250 SUITE 105
RALEIGH, NC 27610
SERVICE 919-279-5400
PHONE 919-279-5400
FAX 919-255-3401

HARNETT COUNTY DSS
UPFIT 2ND FLOOR
HARNETT COUNTY DSS
311 W CORNELIUS HARNETT B
LILLINGTON, NC 27546

ISSUE LOG

MARK	DATE	CD	CHK	DESCRIPTION
T	08/07/24	TP	US	REVISED PER REVIEW COMMENTS

REVISION 1

DRAWN BY:	T PALCZUK
CHECKED BY:	J SIMMONS
ISSUE DATE:	7/23/24
JOB #:	250581495
PROJECT #:	24-650581495

JOHNSON CONTROLS © 2024

SYSTEM:
FIRE ALARM SYSTEM

SHEET:

WIRING TYPICALS

FA-701

PROJECT: HARNETT COUNTY DSS 2FL RENOVATION

CONTRACTOR: KENNEDY ELECTRIC SERVICE

PROJECT NUMBER: 24:650581495

LOCATION: LILLINGTON, NC

FIRE ALARM SYSTEM

DATE: 07-23-2024

Submitted By:



540 Civic Boulevard, Suite 105
Raleigh, NC 27610

919-279-6400
FAX 919-279-6439

Sales Rep: Stephen Sander

Prepared by: Joe Simmons



Project: Harnett County DSS 2FL reno - CPQ-581495
Johnson Controls Reference: 650581495

Date: 06/18/2024

QTY	MODEL NUMBER	DESCRIPTION
1	4098-9755	DUCT SENSOR HOUSING
1	4098-9856	"SAMPLING TUBE 49"', PLASTIC"
1	2098-9806	REMOTE TEST STATION
1	4090-9008	DUAL RELAY IAM, IDNET
1	4090-9802	COVER-ADDRESS MODULE SURFACE
5	4098-9714	PHOTO SENSOR
5	4098-9792	SENSOR BASE
3	4906-9101	STROBE MC RED
4	4906-9127	HORN/STROBE MC RED
3	4906-9128	HORN/STROBE MC RED CEILING
1	4009-9201	NAC EXTENDER 120VAC, IDNET
2	2081-9288	BATTERY 12.7AH
1	DTK-TSS4D	1.5kVA Uninterruptible Power S

Fire, Security, Communications, Sales & Service
Offices & Representatives in Principal Cities throughout North America

UL, ULC, CSFM Listed; FM Approved;
MEA (NYC) Acceptance*

Addressable Duct Sensor Housings with TrueAlarm
Photoelectric Sensor; Available with Multiple Relay Control

Features

Compact air duct sensor housing with clear cover to monitor for the presence of smoke**

Includes factory installed TrueAlarm photoelectric smoke sensor and features:

- Individual sensor information processed by the host control panel to determine sensor status
- Digital transmission of analog sensor values via IDNet or MAPNET II, 2-wire communications
- Programmable sensitivity, consistent accuracy, environmental compensation, status testing, and monitoring of sensor dirt accumulation

Model 4098-9755:

- Basic duct sensor housing (no relay output) powered by IDNet/MAPNET II communications

Model 4098-9756:

- Duct sensor housing with supervised output for multiple remote relays; requires separate 24 VDC; includes one relay
- Relay output is under panel control
- At the panel, relay output can be activated manually or in response to a separate alarm or other input

General features:

- UL listed to Standard 268A
- Clear cover allows visual inspection
- Test ports provide functional smoke testing access with cover in place
- Mounts to rectangular ducts or round ducts; minimum size is 8" (203 mm) square or 18" (457 mm) diameter
- Magnetic test feature for alarm initiation at housing
- Optional weatherproof enclosure is available separately (refer to data sheet S4098-0032)

Diagnostic LEDs (on interface board):

- Red Alarm/Trouble LED for sensor status and communications polling display
- Yellow LED for open or shorted trouble indication of supervised relay control (4098-9756 only)

Sampling tubes (ordered separately):

- Available in multiple lengths to match duct size
- Installed and serviced with housing in place

Remote module options (ordered separately):

- Remote red status/alarm LED (2098-9808)
- Remote test station with LED (2098-9806)
- 4098-9843 remote relays (refer to page 2 for details)

* These products have been approved by the California State Fire Marshal (CSFM) pursuant to Section 13144.1 of the California Health and Safety Code. See CSFM Listing 3240-0026.241 for allowable values and/or conditions concerning material presented in this document. Accepted for use – City of New York Department of Buildings – MEA35-93E. Additional listings may be applicable; contact your local Simplex product supplier for the latest status. Listings and approvals under Simplex Time Recorder Co. are the property of Tyco Fire Protection Products.

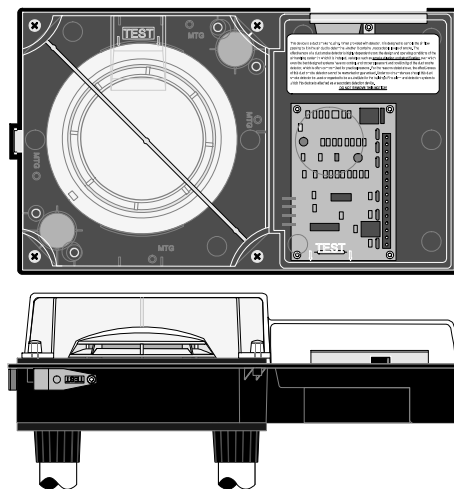

Duct Sensor Housing, Front and Bottom View

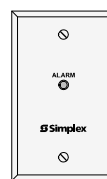

2098-9808

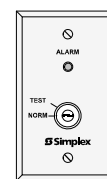

2098-9806

Remote Status/Alarm Indicator and Test Station

Introduction

Operation. Simplex® compact air duct smoke sensor housings provide TrueAlarm operation for the detection of smoke in air conditioning or ventilating ducts. Sampling tubes are installed into the duct allowing air to be directed to the smoke sensor mounted in the housing.

TrueAlarm Sensor Operation

Digital Communication of Analog Sensing.

Analog information from the sensor is digitally communicated to the control panel where it is analyzed. Sensor input is stored and tracked as an average value with an alarm or abnormal condition being determined by comparing the sensor's present value against its average.

Intelligent Data Evaluation. Monitoring each photoelectric sensor's average value provides a software filtering process that compensates for environmental factors (dust, dirt, etc.) and component aging, providing an accurate reference for evaluating new activity. The result is a significant reduction in the probability of false or nuisance alarms caused by shifts in sensitivity, either up or down.

** Please note that smoke detection in air ducts is intended to provide notification of the presence of smoke *in the duct*. It is not intended to, and will not, replace smoke detection requirements for open areas or other non-duct applications.

TrueAlarm Sensor Operation (Continued)

Control Panel Selection. Peak activity per sensor is stored to assist in evaluating specific locations. The alarm set point for each sensor is determined at the control panel, selectable as the individual application requires.

Sensor Status LED. Each sensor housing's red status LED (located on the electrical interface board) pulses to indicate communications with the panel. If the control panel determines that a sensor is in alarm, or that it is dirty or has some other type of trouble, the details are annunciated at the control panel and that sensor housing's status LED will be turned on steadily. During a system alarm, the control panel will control the LEDs such that an LED indicating a trouble will return to pulsing to help identify any alarmed sensors. (Remote Status/Alarm LEDs track the operation of the sensor housing LED.)

Photoelectric Sensing

TrueAlarm photoelectric sensors use a stable, pulsed infrared LED light source and a silicon photodiode receiver to provide consistent and accurate low power smoke sensing.

Duct Sensor Selection Chart

Duct Smoke Sensor Housing with Photoelectric Sensor*

Model	Description	Compatibility
4098-9755	Basic Duct Sensor Housing; operating power is supplied by either IDNet or MAPNET II communications (no relay output)	4007ES, 4008, 4010, 4010ES, 4020, 4100, 4100ES, 4100E, and 4120. Also 2120 CDT if configured for MAPNET II, TrueAlarm operation
4098-9756	Duct Sensor Housing with supervised multiple relay output, requires separate 24 VDC fire alarm power and 4081-9008 end-of-line resistor harness; includes one 4098-9843 relay	Same as above except relay operation is not compatible with 2120 CDT; Relay output is for up to 15 total 4098-9843 Relays (additional relays are ordered separately)

Remote LED Indicator and Test Station, Select One if Required

Model	Description	Compatibility	Mounting
2098-9808	Red LED status indicator on single-gang stainless steel plate	4098-9755 4098-9756	Use single gang box, 3" H x 2" W x 2" D (76 mm x 51 mm x 51 mm)
2098-9806	Test Station with keyswitch and red LED status indicator, on single-gang stainless steel plate; (turning switch to "TEST" initiates alarm for system testing)		

Epoxy Encapsulated Remote Relay and End-of-Line Resistor

Model	Description	Compatibility	Location
4098-9843	Relay; single Form C (7 A @ 120 VAC); refer to pages 3 and 4 for additional relay information; one included with 4098-9756; wiring is 18 AWG (0.82 mm ²) color coded wire leads	4098-9756 only; connect up to 15	Locate relays within 3 ft (1 m) of device being controlled per NFPA 72
4081-9008	End-of-Line Resistor Harness; 10 kΩ, 1/2 W; (ref. 733-894); required to supervise remote relay coil connection	4098-9756	At last relay location

* Each duct housing includes an internally mounted model 4098-9714 TrueAlarm photoelectric sensor and an exhaust tube. A correctly sized sampling tube (ordered per application) is required, refer to chart below.

Sampling Tube Selection Chart, Ordered Separately Per Duct Width, Select One

Overall Duct Width	Tube Required	Suggested Cut Length
12" (305 mm)	4098-9854	1/2" (12.7 mm) longer than duct width
13" to 23" (330 mm to 584 mm)	4098-9855	1/2" (12.7 mm) longer than duct width
24" to 46" (610 mm to 1168 mm)	4098-9856	3 in" (76 mm) longer than duct width
46" to 71" (1168 mm to 1803 mm)	4098-9857	3 in" (76 mm) longer than duct width
71" to 95" (1803 mm to 2413 mm)	4098-9858	3 in" (76 mm) longer than duct width

Photoelectric Sensing (Continued)

Typically duct sensor applications require less sensitive settings (such as 2.5% per foot obscuration) due to the ducts being a relative dirty environment. However, the standard seven levels of TrueAlarm sensor sensitivity are available for each individual sensor, ranging from 0.2% to 3.7% per foot of smoke obscuration. Sensitivity is selected and monitored at the fire alarm control panel.

Fire Alarm Control Panel Features

- Individual smoke sensitivity selection
- Sensitivity monitoring that satisfies NFPA 72 sensitivity testing requirements
- Peak value logging allows accurate analysis for sensitivity selection
- Automatic, once per minute individual sensor calibration check verifies sensor integrity
- Automatic environmental compensation
- Smoke sensitivity is displayed in percent per foot
- Ability to display and print detailed sensor information in plain English language
- Relays of model 4098-9756 are under panel control for ON, OFF, or override

Duct Sensor Housing Detail Reference

NOTE: Refer to Installation Instructions 574-776 for additional installation detail and maintenance information.

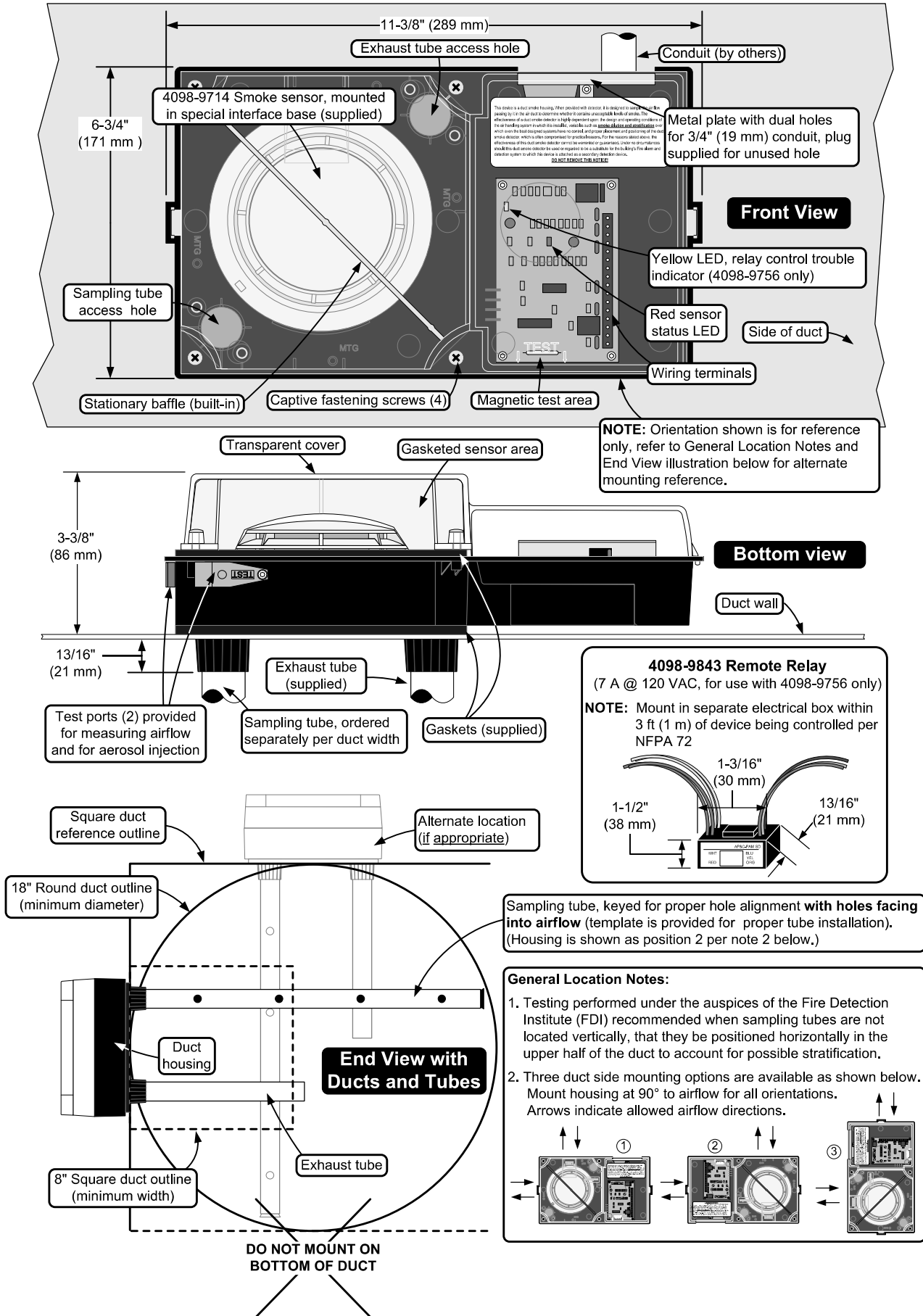

Duct Sensor Location Reference

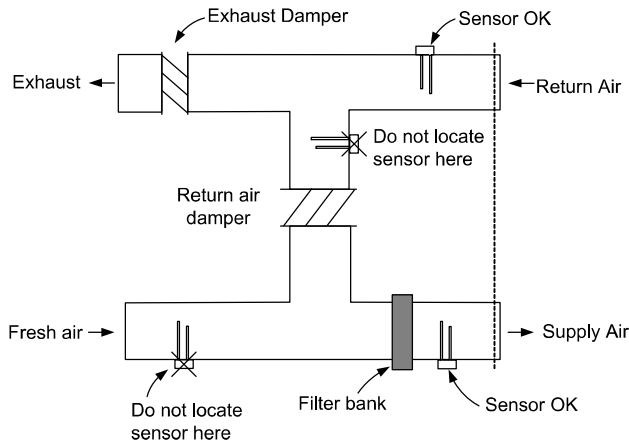

Additional Information. Refer to NFPA 90A, *Standard for the Installation of Air Conditioning and Ventilating Systems*; NFPA 72, the *National Fire Alarm and Signaling Code*; and the *NEMA Guide for Proper Use of Smoke Detectors in Duct Applications*, and Installation Instructions 574-776.

Specifications

General Mechanical and Environmental

Air Velocity Range (linear ft/min)	300 to 4000 ft/min (91 to 1220 m/min)
Sensor Sensitivity Range	0.2% to 3.7% per foot of obscuration, selectable at host control panel
UL Listed Temperature Range	32° F to 100° F (0° C to 38° C)
Operating Temperature Range	32° F to 122° F (0° C to 50° C)
Storage Temperature Range	0° F to 140° F (-18° C to 60° C)
Humidity Range	10% to 95% RH, non-condensing
Wiring Connections	Terminal blocks, 18 to 12 AWG (0.82 mm ² to 3.31 mm ²)
Housing Color and Material	Black ABS base with clear polycarbonate cover
Sampling and Exhaust Tube Material	Black CPVC, custom extrusion; sampling tubes are pre-drilled

Remote Status/Alarm LED and Test Station with Remote Status/Alarm LED

Remote Alarm LED Current	1.2 mA, no impact to 24 VDC alarm current (2098-9808 or 2098-9806)
Test Station Keyswitch Current	3.3 mA, no impact to 24 VDC alarm current (2098-9806)
Remote Alarm LED and Test Station Distance	250 ft (76 m) maximum

Addressable Operation

Data Communications	IDNet or MAPNET II communications, auto-select, one address per housing; provides operating power to model 4098-9755
---------------------	--

Model 4098-9756 with Supervised Multiple Relay Control, Requires Separate Fused 24 VDC from Fire Alarm Power Supply

Input Voltage	18-32 VDC (24 VDC nominal)
Standby Current	3 mA @ 24 VDC
Alarm Current	15 mA @ 24 VDC; add 15 mA for each 4098-9843 relay
Supervised Remote Relay Control Output	For use with 4098-9843 relay only, quantity of 15 maximum; distance of 500 ft (152 m) maximum; requires 4081-9008 (ref. 733-894) 10 k Ω , 1/2 W end-of-line resistor

4098-9843 Relay Output Ratings, Single Form C, use with Model 4098-9756 Only

Coil Current	15 mA @ 24 VDC, up to 15 maximum per relay control output
Relay Contacts	7 A at 0.35 PF @ 28 VDC & 120 VAC; 250 μ A @ 5 VDC
Location Distance	500 ft (152 m) maximum to relay coils; locate relays within 3 ft (1 m) of device being controlled per NFPA 72

Duct Sensor Location Considerations:

1. Proper duct smoke detection location must ensure adequate airflow within the duct housing.
2. Duct air velocity rating is 300 to 4000 ft/min (91 to 1220 m/min). Pressure differential between intake and exhaust tubes is required to be between 0.015 to 1.55 inches of water (0.381 to 39.37 mm).
3. Ensure accessibility for test and service.
4. Proper Locations: downstream side of filters to detect fires in the filters; in return ducts, ahead of mixing areas; upstream of air humidifier and cooling coil.
5. Other locations and orientations may be required for proper duct smoke detection depending on duct access, system design, and duct airflow testing. Contact your local Simplex product supplier for assistance.

Locations to Avoid:

1. Where dampers closed for comfort control would interfere with airflow.
2. Next to outside air inlets (unless the intent is to monitor smoke entry from that area).
3. In return air damper branch ducts and mixing areas where airflow may be restricted.

TYCO, SIMPLEX, and the product names listed in this material are marks and/or registered marks. Unauthorized use is strictly prohibited. NFPA 72 and National Fire Alarm and Signaling Code are registered trademarks of the National Fire Protection Association (NFPA).



Tyco Fire Protection Products • Westminister, MA • 01441-0001 • USA

S4098-0030-10 11/2014

www.simplex-fire.com

© 2014 Tyco Fire Protection Products. All rights reserved. All specifications and other information shown were current as of document revision date and are subject to change without notice.

Features

Dual Contact Relay IAM (Individual Addressable Module):

- A single addressable point provides control and status tracking of two, 2 A Form “C” contacts
- Low power latching relay design allows IDNet or MAPNET II communications to supply both data and module power
- Relay is set to OFF on initial power up and upon loss of IDNet or MAPNET II communications

For use with following Simplex control panels:

- Model Series 4007ES, 4010ES, 4100ES, and 4100U fire alarm control panels for IDNet communications
- Model Series 4100/4100U/4100ES, 4120, 4020, and 2120 Communicating Device Transponders (CDTs) equipped with MAPNET II communications

Compact construction:

- Mounts in standard 4” (102 mm) square electrical box, optional adapter bracket is available to mount in a 4 11/16” square electrical box
- Screw terminals for wiring connections
- Visible LED flashes to indicate communications, can be selected at panel to indicate activated state
- Optional 4” square box covers are available to allow LED to be viewed after installation

UL listed to Standard 864

Description

Dual Contact Relay IAMs allow fire alarm control panels to control two remotely located Form “C” contact using IDNet or MAPNET II addressable communications for both data and module power. Typical applications would be for switching local power for control functions such as elevator capture, or control of HVAC components, pressurization fans, dampers, etc. Relay status is also communicated requiring only one device address.

Product Selection

Model	Description
4090-9008	Dual Contact Relay IAM

Optional Adapter Plates

Model	Description	
4090-9813	Adapter plate to fit 4 11/16” (119 mm) square electrical box	
4090-9801	For semi-flush mounted box	Optional trim plate for 4” boxes with LED viewing window, includes mounting screws; galvanized steel
4090-9802	For surface mounted box	

* This product has been approved by the California State Fire Marshal (CSFM) pursuant to Section 13144.1 of the California Health and Safety Code. See CSFM Listing 7300-0026:0311 for allowable values and/or conditions concerning material presented in this document. Additional listings may be applicable; contact your local Simplex product supplier for the latest status. Listings and approvals under Simplex Time Recorder Co. are the property of Tyco Fire Protection Products.

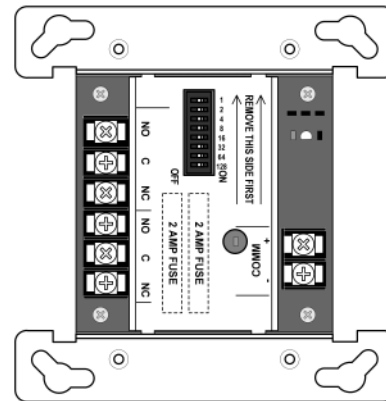

4090-9008 Dual Contact Relay IAM
(shown approximately 1/2 size)

Specifications

Communications	IDNet or MAPNET II communications, 1 address per device
Power	Supplied by communications
Installation Instructions	579-1040
IDNet Firmware	Requires 3.12.04 or higher
Contact Ratings* (not rated for incandescent switching)	
Type	Dual Form C contacts (DPDT) with terminal block access to Common, N.O., and N.C for each contact
Power-Limited	2 A @ 30 VDC, resistive
	1 A @ 30 VDC, inductive
Nonpower-Limited	0.5 A @ 125 VAC, resistive
Relay Fusing	Each contact common is fused with a 2 A fast acting non-time delay fuse
* Provide external transient suppression as required per application. DC inductive loads can typically be diode suppressed; 120 VAC loads may require RC networks or varistors, depending on device type. Refer to Installation Instructions for additional information.	
Wire Connections	Screw terminals for in/out wiring, 18 to 14 AWG wire (0.82 to 2.08 mm ²)
IDNet or MAPNET II Communications Wiring Reference	Up to 2500 ft (762 m) from control panel
	Up to 10,000 ft (3048 m) total wiring distance (including T-Taps)
	Compatible with Simplex 2081-9044 Overvoltage Protectors
Dimensions	4 1/8" H x 4" W x 1 3/8" D (105 mm x 102 mm x 35 mm)
Mounting Plate	Sheet metal, galvanized
Temperature Range	32° to 120° F (0° to 49° C), intended for indoor operation
Humidity Range	Up to 93% RH at 100° F (38° C)

Dual Contact Relay IAM Mounting Information

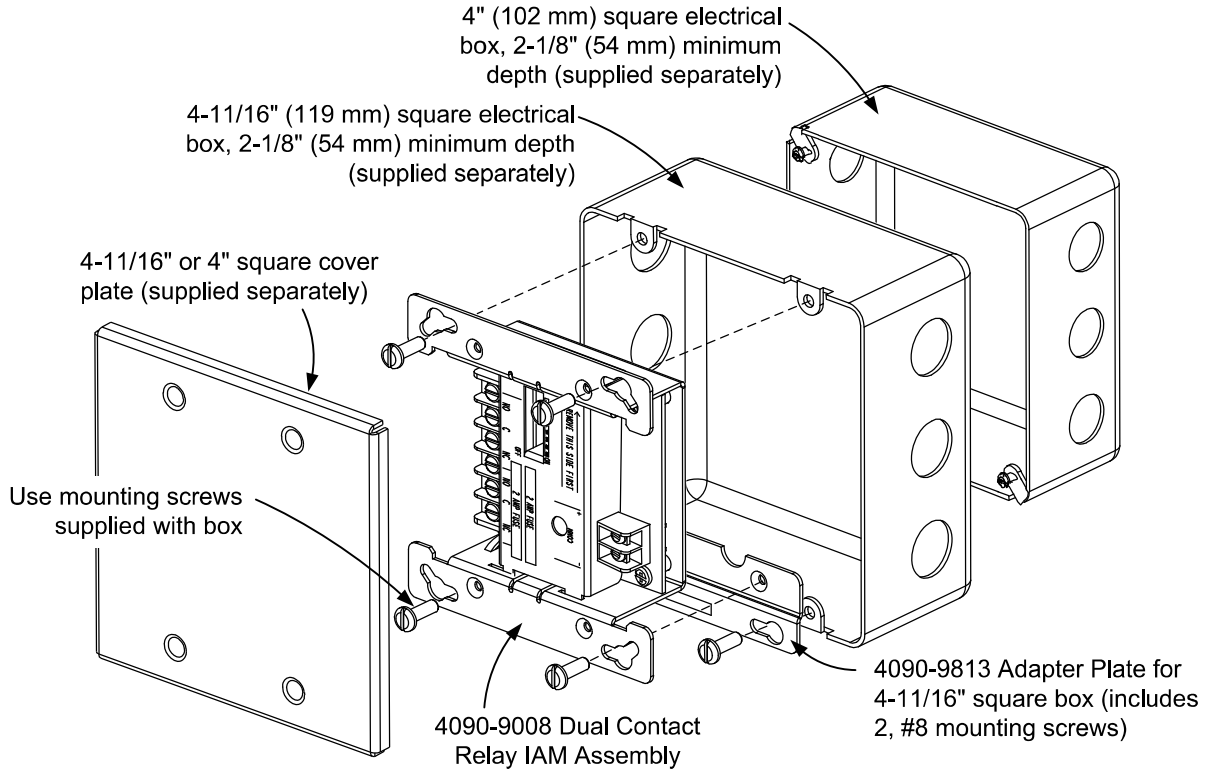

Mounting Reference with 4-11/16" Square and 4" Square Boxes

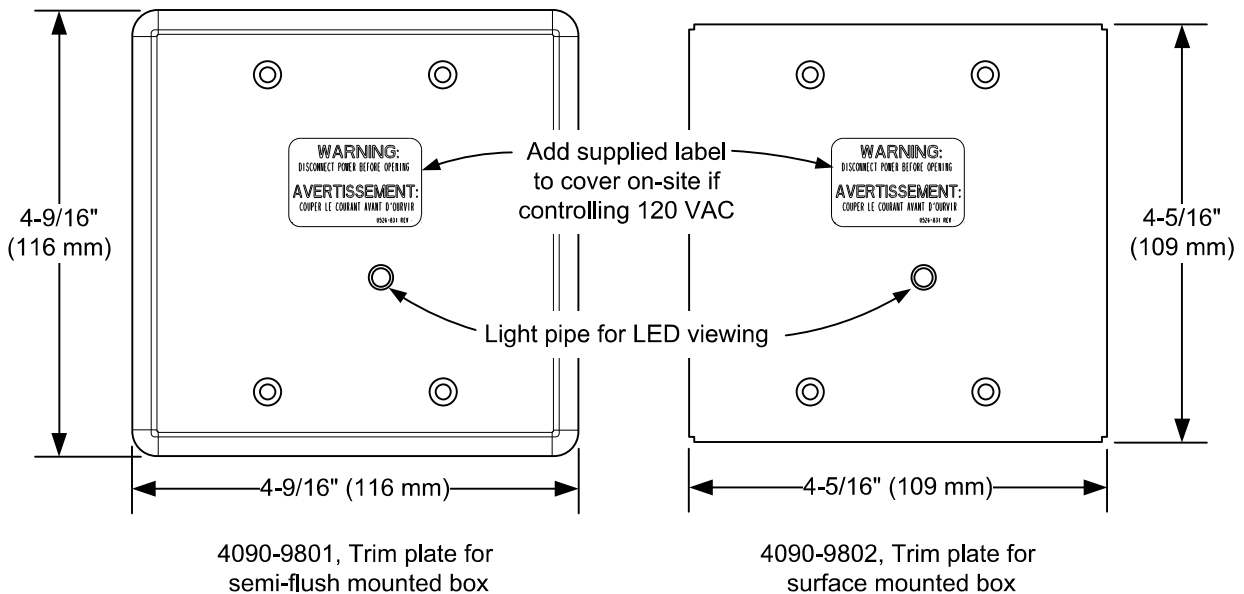

Optional Trim Plates for 4" Square Boxes with Visible LED

TYCO, SIMPLEX, and the product names listed in this material are marks and/or registered marks. Unauthorized use is strictly prohibited.



Tyco Fire Protection Products • Westminister, MA • 01441-0001 • USA
www.simplex-fire.com

S4090-0014-3 11/2014

© 2014 Tyco Fire Protection Products. All rights reserved. All specifications and other information shown were current as of document revision date and are subject to change without notice.

Features

TrueAlarm analog sensing provides the following features

- Digital transmission of analog sensor values using IDNet or MAPNET II two-wire communications

For use with the following Simplex products

- 4007ES, 4010, 4010ES, 4100ES, and 4100U Series control units ; and 4008 Series control units with reduced feature set (refer to data sheet *S4008-0001* for details)
- 4020, 4100, and 4120 Series control units, Universal Transponders, and 2120 TrueAlarm CDTs equipped for MAPNET II operation

Fire alarm control unit provides the following features

- Peak value logging with accurate analysis of each sensor for individual sensitivity selection
- Sensitivity monitoring meets NFPA 72 sensitivity testing requirements; automatic individual sensor calibration check verifies sensor integrity
- Automatic environmental compensation, multi-stage alarm operation, and display of sensitivity directly in percent for each foot
- Display and print detailed sensor information in plain English language

Photoelectric smoke sensors provide the following features

- Sensitivity levels from 0.2% to 3.1%. See [TrueAlarm sensors](#) for more information.

Heat sensors have these features

- Three fixed temperature sensing thresholds: 135°F, 155°F and 190°F
- Rate-of-rise temperature sensing
- Utility temperature sensing
- Listed to UL 521 and ULC-S530

General features

- Ceiling or wall mounting
- Listed to UL 268 7th Edition and ULC-S529
- NEMA 1 rated. See [TrueAlarm analog sensing product selection chart](#) for more information.
- Louvered smoke sensor design enhances smoke capture by directing flow to chamber; entrance areas are minimally visible when ceiling mounted
- Designed for EMI compatibility
- Magnetic testing
- Different bases support a supervised or unsupervised output relay, or a remote LED alarm indicator

Additional base reference

- For isolator bases, refer to data sheet *S4098-0025*
- For sounder bases, refer to data sheet *S4098-0028*
- For photo/heat sensors, refer to data sheet *S4098-0024* , single address and *S4098-0033* , dual address

Description

Digital communication of analog sensing

TrueAlarm analog sensors provide an analog measurement digitally communicated to the host control panel using Simplex addressable communications. The control unit analyses the data, determines an

average value and stores it. Comparing the sensor's present value against its average value and time, determines an alarm or other abnormal condition.

Intelligent data evaluation

Monitoring each sensor's average value provides a continuously shifting reference point. A software filtering process compensates for environmental factors, such as dust and dirt, and component aging, to provide an accurate reference for evaluating new activity. This filtering reduces the probability of false or nuisance alarms caused by shifts in sensitivity, either up or down.

Control unit selection

The control unit stores peak activity for each sensor to assist in evaluating specific locations. The host control unit determines the alarm set point for each TrueAlarm sensor, selectable as more or less sensitive as the individual application requires.

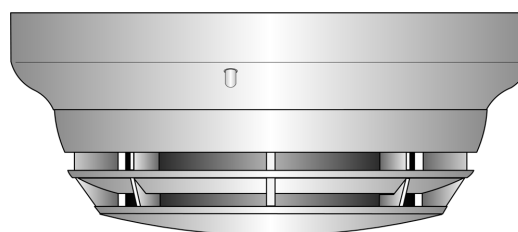

Figure 1: 4098-9714 TrueAlarm photoelectric sensor mounted in base

Timed/multi-stage selection

You can program the sensor alarm set points for timed automatic sensitivity selection, such as more sensitive at night, less sensitive during day. You can program the control unit to provide multi-stage operation for each sensor.

Sensor alarm and trouble LED indication

Each sensor base's LED pulses to indicate communications with the unit. If the control unit determines a sensor is in alarm, is dirty, or has some other type of trouble, the details are annunciated at the control unit and the sensor's base LED will turn on steadily. During a system alarm, the control unit will control the LEDs such that an LED indicating a trouble will return to pulsing to help identify the alarmed sensors.

TrueAlarm sensor bases and accessories

Sensor base features

Base mounted address selection

- Address remains with its programmed location
- Accessible from front, DIP switch under sensor

General features

- Automatic identification provides default sensitivity when substituting sensor types
- Integral red LED for power-on, pulsing, or alarm or trouble, steady on
- Locking anti-tamper design mounts on standard outlet box
- Magnetically-operated functional test

* These products have been approved by the California State Fire Marshal (CSFM) pursuant to Section 13144.1 of the California Health and Safety Code. See CSFM Listings 7272-0026:218, 7271-0026:231, 7270-0026:216, and 7300-0026:217 for allowable values and/or conditions concerning material presented in this document. Additional listings may be applicable, contact your local Simplex product supplier for the latest status. Listings and approvals under Simplex Time Recorder Co. are the property of Tyco Fire Protection Products.

Sensor bases

4098-9792, standard sensor base

4098-9789, sensor base with wired connections

- 2098-9808 remote LED alarm indicator or 4098-9822 relay (relay is unsupervised and requires separate 24 VDC)

Supervised relay bases not compatible with 2120 CDT:

- **4098-9791, 4-wire sensor base**, use with remote or locally mounted 2098-9737 relay, requires separate 24 VDC
- **4098-9780, 2-wire sensor base**, use with remote or locally mounted 4098-9860 relay, no separate power required
- Supervised relay operation is programmable and can be manually operated from control unit
- Includes wired connections for remote LED alarm indicator **or** 4098-9822 relay, relay is unsupervised and requires separate 24 VDC

Sensor base options

2098-9737, remote or local mount supervised relay

- DPDT contacts for resistive/suppressed loads
- power limited rating of 3 A at 28 VDC
- non-power limited rating of 3 A at 120 VAC, requires external 24 VDC coil power

4098-9860, remote or local mount supervised relay

- SPDT dry contacts, power limited rating of 2 A at 30 VDC, resistive; non-power limited rating of 0.5 A at 125 VAC, resistive

4098-9822, LED annunciation relay

- Activates when base LED is on steady, indicating local alarm or trouble
- DPDT contacts for resistive/suppressed loads, power limited rating of 2 A at 28 VDC; non-power limited rating of 1/2 A at 120 VAC, (requires external 24 VDC coil power)

4098-9832, adapter plate

- Required for surface or semi-flush mounting to 4 in. square electrical box and for surface mounting to 4 in. octagonal box
- Can be used for cosmetic retrofitting to existing 6 3/8 in. diameter base product

2098-9808, remote red LED alarm indicator

- Mounts on single gang box



Figure 2: Remote red LED alarm indicator

Description

TrueAlarm sensor bases contain integral addressable electronics that constantly monitor the status of the detachable photoelectric or heat sensors. Each sensor's output is digitized and transmitted to the system fire alarm control unit every four seconds.

You can easily interchange different TrueAlarm sensor types to meet specific location requirements. This feature allows intentional sensor substitution during building construction. When conditions are temporarily dusty, you can install heat sensors without reprogramming the control unit, as covering smoke sensors causes them to be disabled. Although the control unit will indicate an incorrect sensor type, the heat sensor will operate at a default sensitivity providing heat detection for building protection at that location.

Mounting reference

Electrical Box Requirements: (boxes are by others)

Without relay in the box: 4" octagonal or 4" square, 1-1/2" deep; single gang, 2" deep

With relay in the box: 4" octagonal or 4" square, 1-1/2" deep, with 1-1/2" extension ring

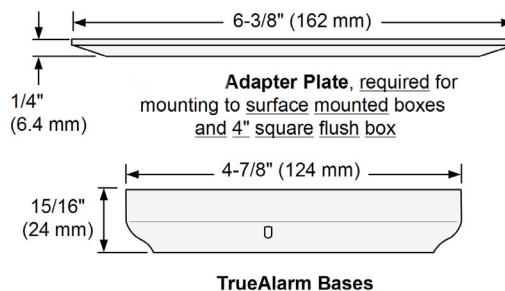
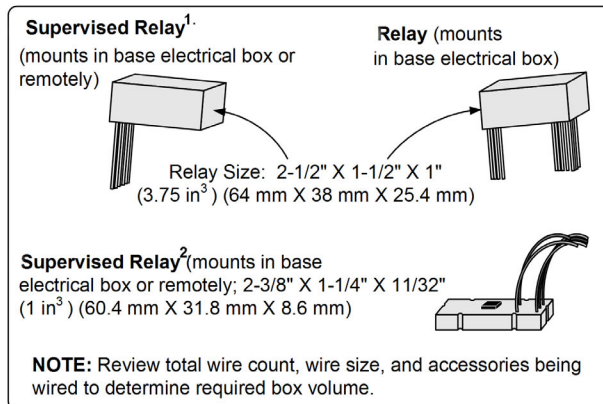
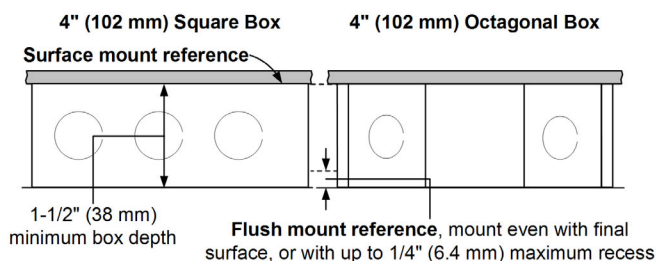

Figure 3: Mounting reference

Table 1: Product mounting - SKU reference

Product	SKU
Relay	4098-9822
Supervised relay	Example 1 2098-9739 Example 2 4098-9860
Adapter plate	4098-9832
TrueAlarm bases	4098-9780, 4098-9789, 4098-9791, 4098-9792

TrueAlarm sensors

Features

- Sealed against rear air flow entry
- Interchangeable mounting
- EMI/RFI shielded electronics
- Heat sensors:
 - Selectable rate compensated, fixed temperature sensing with or without rate-of-rise operation
 - Rated spacing distance between sensors:

Fixed Temp. Setting	UL and ULC Spacing	FM Spacing, Either Fixed Temperature Setting
135°F (57.2°C) 190°F (88°C)	60 ft x 60 ft (18.3 m)	20 ft x 20 ft (6.1 m) for fixed temperature only; RTI = Quick
155°F (68°C)	40 ft x 40 ft (12.2 m)	50 ft x 50 ft (15.2 m) for fixed temperature with either rate-of-rise selection; RTI = Ultra Fast

Note: 190°F (88°C) ratings apply only to the 4098-9734 sensor.

Smoke sensors

- Photoelectric technology sensing
- 360° smoke entry for optimum response
- Built-in insect screens

4098-9714 photoelectric sensor

TrueAlarm photoelectric sensors use a stable, pulsed LED light source and a silicon photodiode receiver to deliver consistent and accurate low power smoke sensing. There are three user-selectable sensitivities for special applications for each individual sensor: 0.2%, 0.5%, and 1% for each foot. Standard sensitivity is 1.25% to 3.1% for each foot. The fire alarm control unit runs an algorithm that can vary the sensitivity for normal applications between 1.25% and 3.1% for each foot.

Note: Fixed sensitivity settings higher than 1.0% for each foot are not UL268 7th Edition compliant.

The sensor head design provides 360° smoke entry for optimum response to smoke from any direction. Due to its photoelectric operation, air velocity is not normally a factor, except for impact on area smoke flow.

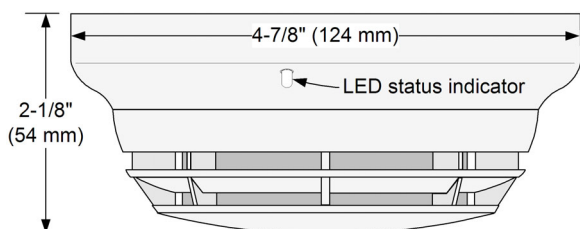

Figure 4: 4098-9714 photoelectric sensor with base

4098-9733 and 4098-9734 heat sensors

TrueAlarm heat sensors are self-restoring and provide rate-compensated, fixed temperature sensing, you can select with or without rate-of-rise temperature sensing. Due to its small thermal mass, the sensor accurately and quickly measures the local temperature for analysis at the fire alarm control unit.

You can select rate-of-rise temperature detection at the control unit for either 15°F or 20°F (8.3°C or 11.1°C) for each minute. Fixed temperature sensing is independent of rate-of-rise sensing and you can program it to operate at 135°F or 155°F (57.2°C or 68°C). The 4098-9734 sensor provides an additional 190°F (88°C) set point.

In a slowly developing fire, the temperature may not increase rapidly enough to operate the rate-of-rise feature. However, an alarm will be initiated when the temperature reaches its rated fixed temperature setting.

You can program TrueAlarm heat sensors as a utility device to monitor for temperature extremes in the range of 32°F to 155°F (0°C to 68°C). This feature can provide freeze warnings, or alert you to HVAC system problems. Refer to panel specifications for availability.

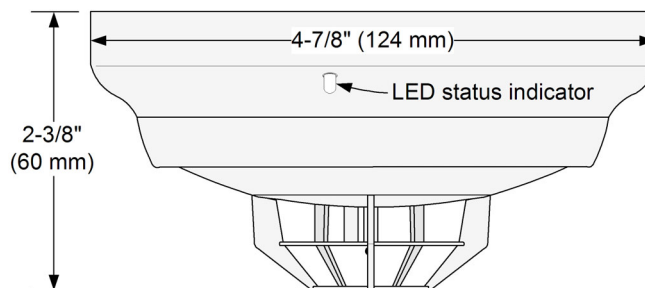

Figure 5: 4098-9733 heat sensor with base

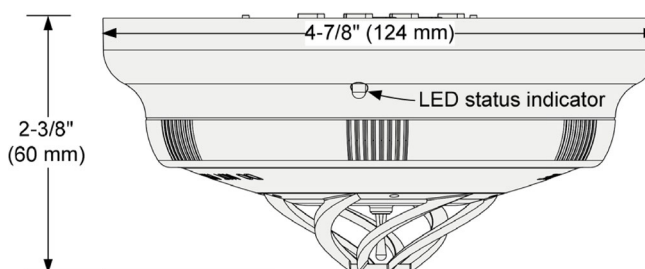

Figure 6: 4098-9734 high temperature heat sensor with base

WARNING: In most fires, hazardous levels of smoke and toxic gas can build up before a heat detection device would initiate an alarm. In cases where Life Safety is a factor, the use of smoke detection is highly recommended.

Application reference

Sensor locations should be determined only after careful consideration of the physical layout and contents of the area to be protected. Refer to NFPA 72, *the National Fire Alarm and Signaling Code*. On smooth ceilings, a smoke sensor spacing of 30 ft (9.1 m) can be used as a guide.

For detailed application information including sensitivity selection, refer to *Installation Instructions 574-709*.

TrueAlarm analog sensing product selection chart

Table 2: TrueAlarm sensor bases (for use with sensors 4098-9714 and 4098-9733)

SKU	Color	Description	Compatibility	Mounting requirements
4098-9792 GSA4098-9792	White	Standard sensor base	No options	4 in. octagonal or 4 in. square box, 1 1/2 in. min. depth; or single gang box, 2 in. min. depth
4098-9776	Black			
4098-9789 4098-9789IND GSA4098-9789	White	Sensor base with connections for remote LED alarm indicator or unsupervised relay	2098-9808 remote alarm indicator or 4098-9822 unsupervised relay	4 in. octagonal or 4 in. square box
4098-9775	Black			
4098-9791	White	4-wire sensor supervised relay base with connections for LED indicator or unsupervised relay	2098-9737 supervised remote relay	Note: Box depth requirements depend on total wire count and wire size, see Table 4 for reference.
Note: NOT compatible with the 2120 CDT			2098-9808 remote alarm indicator or 4098-9822 unsupervised relay	
4098-9780	White	2-wire sensor supervised relay base with connections for LED indicator or unsupervised relay	4098-9860 supervised remote relay	
GSA4098-9780 Note: NOT compatible with the 2120 CDT			2098-9808 remote alarm indicator or 4098-9822 unsupervised relay	

Note: SKU numbers ending in IND are assembled in India. SKU numbers with GSA prefix are assembled in the USA.

Refer to *Application Manual 574-709* and *Installation Instructions 574-707* for additional information.

Table 3: TrueAlarm sensors

SKU	Color	Description	Compatibility	Mounting requirements
4098-9714 4098-9714-IND GSA4098-9714	White	Photoelectric smoke sensor	Bases 4098-9775, 4098-9776, 4098-9792, 4098-9789, 4098-9791, and 4098-9780	Refer to base requirements
4098-9774	Black			
4098-9733 GSA4098-9733	White	Heat sensor		
4098-9778	Black			
4098-9734 GSA4098-9734	White	High temperature heat sensor		

Note:

- All of these SKUs are NEMA 1 rated.
- The 4098-9734 Heat Sensor is compatible with IDNet on the 4100ES, 4010ES, and 4007ES only.
- SKU numbers with GSA prefix are assembled in the USA.

Table 4: TrueAlarm sensor/base accessories

SKU	Description	Compatibility	Mounting requirements
2098-9737	Supervised relay, mounts remote or in base electrical box	For use with 4098-9791 base	Remote mounting requires 4 in. octagonal or 4 in. square box, 1 1/2 in. minimum depth
4098-9860	Supervised relay, mounts remote or in base electrical box	For use with 4098-9780 base	Base mounting requires 4 in. octagonal box, 2 1/8 in. deep with 1 1/2 in. extension ring
2098-9808	Remote red LED alarm indicator on single gang stainless steel plate	Bases 4098-9789, 4098-9791, and 4098-9780	Single gang box, 1 1/2 in. minimum depth
4098-9822	Unsupervised relay, tracks base led status. Note: Mounts only in base electrical box.	Bases 4098-9789, 4098-9791, and 4098-9780	4 in. octagonal box, 2 1/8 in. deep with 1 1/2 in. extension ring
4098-9832	Adapter plate	Bases 4098-9792, 4098-9789, 4098-9791, and 4098-9780	Required for surface or semi-flush mounted 4 in. square box and for surface mounted 4 in. octagonal box

Note: 2098-9808 is NEMA 1 rated.

Specifications

Table 5: General operating specifications

Specification	Rating	
Communications and sensor supervisory power	IDNet or MAPNET II communications, auto-selected, one address for each base	
Communications connections	Screw terminals for in/out wiring, 18 to 14 AWG, 0.82 mm ² to 2.08 mm ²	
Remote LED alarm indicator current	1 mA typical, no impact to alarm current	
Remote LED alarm indicator and relay connections	Color coded wire leads, 18 AWG, 0.82 mm ²	
UL listed operating temperature range	32°F to 100°F, 0°C to 38°C	
Operating temperature range	with 4098-9733 Heat Sensor	32°F to 122°F, 0°C to 50°C
	with 4098-9714 Smoke Sensor	15°F to 122°F, -9°C to 50°C
	with 4098-9734 Heat Sensor	32°F to 150°F, 0°C to 66°C
Storage temperature range	0°F to 140°F, -18°C to 60°C	
Humidity range	10% to 95% RH	
4098-9714 smoke sensor air velocity rating	0 to 4000 ft/min, 0 to 1220 m/min	
Housing color	Frost white or black	

Table 6: 4098-9791 Base with supervised remote relay 2098-9737

Specification	Rating
Externally supplied relay coil voltage	18 VDC to 32 VDC, nominal 24 VDC
Supervisory current	270 µA, from 24 VDC supply
Alarm current with 2098-9737 relay	28 mA, from 24 VDC supply
Note: See Sensor base options for contact ratings.	

Table 7: 4098-9780 Base with supervised remote relay 4098-9860

Specification	Rating
Power	Supplied from communications

Table 8: 4098-9822 Unsupervised relay, requirements for bases 4098-9789, 4098-9791, and 4098-9780

Specification	Rating
Externally supplied relay coil voltage	18 VDC to 32 VDC, nominal 24 VDC
Supervisory current	Supplied from communications
Alarm current	13 mA from separate 24 VDC supply
Note: See Sensor base options for contact ratings.	

Features



Figure 1: Wall Mount Strobes

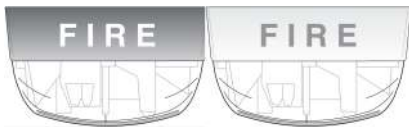

Figure 2: Ceiling Mount Strobes

Visible only (V/O) 24 VDC notification appliances with high output xenon strobe, available for wall or ceiling mount:

- Intensity is selectable as 15, 30, 75, or 110 candela with visible selection jumper secured behind strobe housing
- Operation is compatible with ADA requirements (refer to [Installation Reference, Surface or Semi-Flush Wall Mounting](#))
- Polarized input allows connection to compatible reverse polarity, supervised notification appliance circuit (NAC)
- Regulated circuit design ensures consistent flash output and provides controlled inrush current
- Rugged, high impact, flame retardant thermoplastic housings are available in red or white with clear lens
- Listed to UL 1971 and ULC S526
- NEMA 1 rated. See [Product Selection](#) for more information

Strobes provide synchronized flash for use with:

- Simplex fire alarm control panels with NACs selected to provide strobe synchronization or SmartSync two-wire control
- 4009 IDNet NAC Extenders
- Separate strobe Synchronization Modules that are available for Class B or Class A operation
- Separate SmartSync Control Modules (SCMs) that provide Class B or Class A output from conventional NAC inputs

Strobe housings provides flexible, easy, and convenient semi-flush or surface wall mounting:

- Rear of housing does not extend into box
- Wall mount strobes easily mount to single gang, double gang, or 4-inch square outlet box
- Ceiling mount strobes mount to single gang boxes

Wall mount strobe features:

- Wiring terminals are accessible from the front of the housing providing easy access for installation, inspection, and testing
- Covers are available separately to convert housing color

Optional adapters and wire guards:

- Wall mount strobe adapters are available to cover surface mounted electrical boxes and to adapt to 2975-9145 boxes
- UL listed red wire guards are available for wall or ceiling mount strobes*

Description

Multi-Candela TrueAlert synchronized strobes provide convenient installation to standard electrical boxes. The enclosure designs are both impact and vandal resistant and provide a convenient strobe intensity selection. Since each model can be selected for intensity output, on-site model inventory is minimized and changes encountered during construction can be easily accommodated.

Wall mount strobe housings are a one-piece assembly (including lens) that mounts to a single or double gang, or 4" square standard electrical box. The cover can be quickly removed (a tool is required) and covers are available separately for color conversion.

Ceiling mount strobes install using standard single gang electrical boxes. Color choice is determined by model number.

Strobe Intensity Selection

During installation, a selection plug at the back of the housing determines the desired strobe intensity. An attached flag with black letters on a highly visible yellow background allows the selected intensity to be seen at the side of the strobe lens.

Strobe Application Reference

Proper selection of visible notification is dependent on occupancy, location, local codes, and proper applications of: the *National Fire Alarm Code* (NFPA 72), ANSI A117.1; the appropriate model building code: BOCA, ICBO, or SBCCI; and the application guidelines of the Americans with Disabilities Act (ADA).

Synchronized Strobes

Multiple Strobes. When multiple strobes and their reflections can be seen from one location, synchronized flashes reduce the probability of photo-sensitive reactions as well as the annoyance and possible distraction of random flashing. These multi-candela strobes are synchronized over a two-wire circuit when connected to compatible NACs, to compatible Synchronized Flash Modules, or to SmartSync Control Modules.

SmartSync Two-Wire Control

Some applications desire the audible notification appliances to be capable of being silenced before the alarm condition is reset (on-until-silenced) while the visible notification appliances are kept activated until the alarm condition is reset (on-until-reset). SmartSync operation mode provides this function using a single circuit (two-wire operation).

SmartSync Control Sources

SmartSync two-wire control is available from:

4006, 4007ES Hybrid, 4008, 4010, 4010ES, 4100ES, and 4100U Fire Alarm Control Panels (refer to individual product data sheets for more information)

4009 IDNet NAC Extenders (refer to data sheet [S4009-0002](#))

SmartSync Control Module (SCM) Model 4905-9938 (refer to data sheet [S4905-0003](#))

Additional SmartSync compatible notification appliances include separate horns and combination horn/strobe notification appliances.

For more information refer to installation instructions, 579-548.

Product Selection
Table 1: Multi-Candela Visible Notification Appliances (Strobes)

SKU	Mounting	Housing Color	Lettering	Description
4906-9101 *	Wall	Red	FIRE (white)	Multi-candela strobe with intensity selectable as: 15, 30, 75, or 110 candela; synchronized flash rate; SmartSync two-wire control compatible
4906-9103 *		White	FIRE (red)	
4906-9102 *	Ceiling	Red	FIRE (white)	
4906-9104 *		White	FIRE (red)	
4906-9114 *		Red	ALERT (white)	
4906-9115 *		White	ALERT (red)	
4906-9116 *		Red	Blank (white)	
4906-9117 *		White	Blank (red)	

* NEMA 1 rated when used with 4095-9931 adaptor plate and 2975-9145 back box.

Table 2: Wall Mount Strobe Adapters

SKU	Description	Dimensions
4905-9937	Red Surface Mount Adapter Skirt; use to cover 1-1/2" (38 mm) deep surface mounted boxes	5-3/8" H x 5-1/4" W x 1-5/8" D (136 mm x 133 mm x 41 mm) Total depth with strobe = 4-3/8" (111 mm)
4905-9940	White Surface Mount Adapter Skirt; use to cover 1-1/2" (38 mm) deep surface mounted boxes	5-3/8" H x 5-1/4" W x 1-5/8" D (136 mm x 133 mm x 41 mm) Total depth with strobe = 4-3/8" (111 mm)
4905-9931 **	Red Adapter Plate for mounting to Simplex 2975-9145 box (typically for retrofit, may be mounted vertical or horizontal)	8-5/16" x 5-3/4" x 0.060" Thick (211 mm x 146 mm x 1.5 mm)
2975-9145 **	Red Mounting Box, requires Adapter Plate 4905-9931	7-7/8" x 5-1/8" x 2-3/4" D (200 mm x 130 mm x 70 mm)

** NEMA 1 rated.

Table 3: Ceiling Mount Strobe Adapter

SKU	Description	Dimensions
4905-9910	Surface Mount Adapter Plate; zinc plated; required for mounting to handy box; not needed when using 4905-9926 guard	4-7/8" x 3-1/8" x 0.060" D (124 mm x 79 mm x 1.5)

Table 4: Synchronization Modules (refer to data sheet S4905-0003 for additional information)

SKU	Description	Dimensions
4905-9914	Class B Synchronized Flash Module; epoxy encapsulated with in/out 18 AWG (0.82 mm ²) wire leads, rated for 2 A NAC, requires 5 mA for power	1-3/8" x 2-7/16" x 13/16" (35 mm x 62 mm x 20 mm)
4905-9922	Class A Synchronized Flash Module; epoxy encapsulated with in/out 18 AWG (0.82 mm ²) wire leads, rated for 2 A NAC, requires 5 mA for power	1-3/8" x 2-7/16" x 13/16" (35 mm x 62 mm x 20 mm)
4905-9938	SmartSync Control Module with Class B or Class A output; mounts in 4" (102 mm) square box	4" x 4-1/8" x 1-1/4" D (102 mm x 105 mm x 32 mm)

Table 5: Replacement Covers and Guards

SKU	Description	Dimensions
4905-9992	Red cover with white "FIRE" lettering	For Wall mount strobes 5-1/8" H x 5" W x 1-1/2" D (130 mm x 127 mm x 38 mm)
4905-9993	White cover with red "FIRE" lettering	
4905-9961 *	Wall mount Red wire guard with mounting plate, compatible with semi-flush or surface mounted boxes	6-1/16" H x 6-1/16" W x 3-1/8" D (154 mm x 154 mm x 79 mm)
4905-9926 *	Ceiling mount Red wire guard with mounting plate, compatible with semi-flush or surface mounted boxes	6-1/8" x 4-3/8" x 2-7/8" deep (156 mm x 111 mm x 73 mm)

* UL listed by Space Age Electronics Inc.

Strobe Specifications

Table 6: Wall Mount or Ceiling Mount, Common Specifications

Specification		Rating			
Rated Voltage Range		Regulated 24 VDC; see Note 1 below			
Flash Rate		1 Hz			
Synchronized NAC Loading		Up to 35 synchronized strobes maximum per NAC			
Temperature Range		32° to 122° F (0° to 50° C)			
Humidity Range		10% to 93%, non-condensing at 100° F (38° C)			
Connections		Terminal blocks for 18 AWG to 12 AWG (0.82 mm ² to 3.31 mm ²); two wires per terminal for in/out wiring			
Wall Mount	Housing Dimensions (with lens)	5-1/8" H x 5" W x 2-3/4" D (130 mm x 127 mm x 70 mm)			
	Maximum RMS Current Rating per Strobe Setting (see Note 2 below)	15 cd	30 cd	75 cd	110 cd
		60 mA	94 mA	186 mA	252 mA
	Reference RMS Currents at other voltages	18 VDC	53 mA	84 mA	165 mA
24 VDC		40 mA	63 mA	124 mA	168 mA
Ceiling Mount	Housing Dimensions (with lens)	4-3/4" L x 2-5/16" W x 2-5/8" D (121 mm x 75 mm x 67 mm)			
	Maximum RMS Current Rating per Strobe Setting (see Note 2 below)	15 cd	30 cd	75 cd	110 cd
		75 mA	125 mA	233 mA	316 mA
	Reference RMS Currents at other voltages	18 VDC	67 mA	111 mA	207 mA
24 VDC		50 mA	83 mA	155 mA	211 mA

Note:

- "Regulated 24 VDC" refers to the voltage range of 16 to 33 VDC per UL Standard 1971, *Signaling Devices for the Hearing Impaired*. This voltage range is the absolute operating range. Operation outside of this range may cause permanent damage to the strobe. Please note that 16 VDC is the lowest operating voltage that is allowed at the last appliance on the NAC under worst case conditions.
- The maximum RMS current listed is the device nameplate rating. Strobe designs are constant wattage and the maximum RMS current rating occurs at the lowest allowable operating voltage. (RMS is root mean square and refers to the effective value of a varying current waveform.)

Installation Reference, Surface or Semi-Flush Wall Mounting

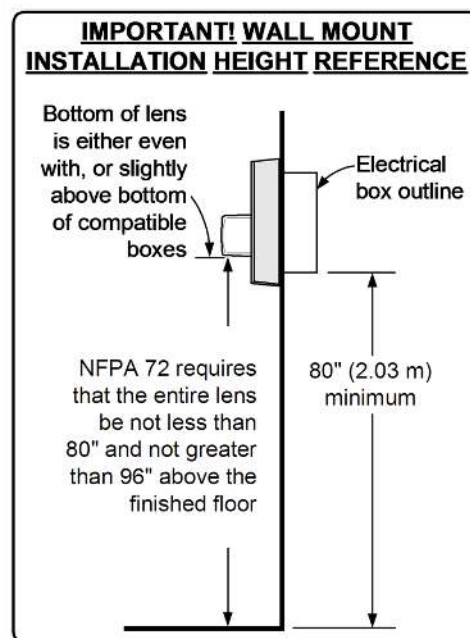
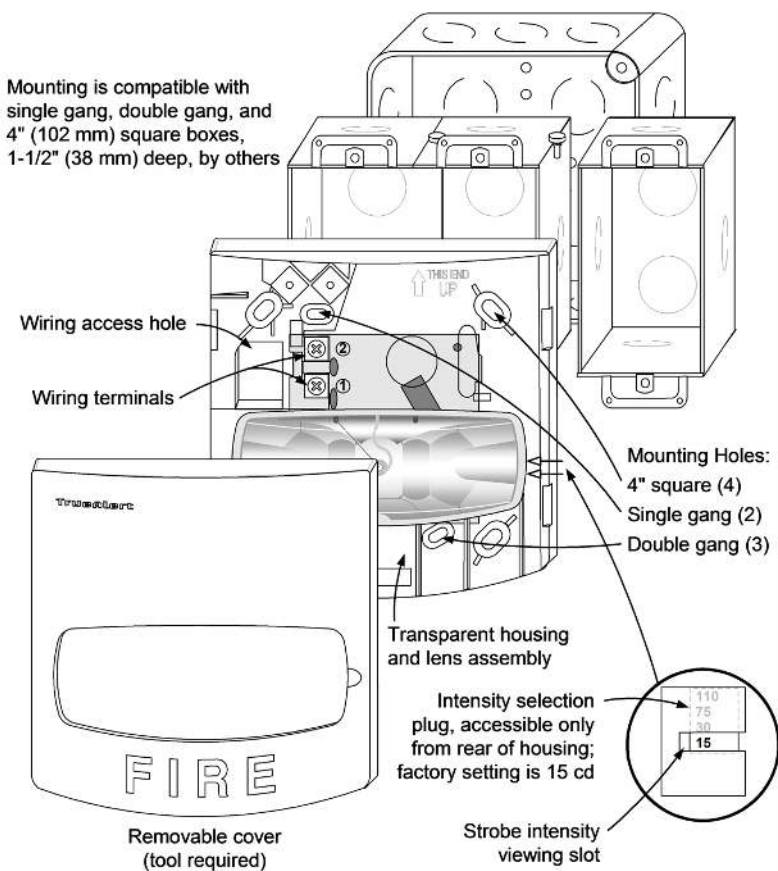

Ceiling Mount Strobe Installation Reference

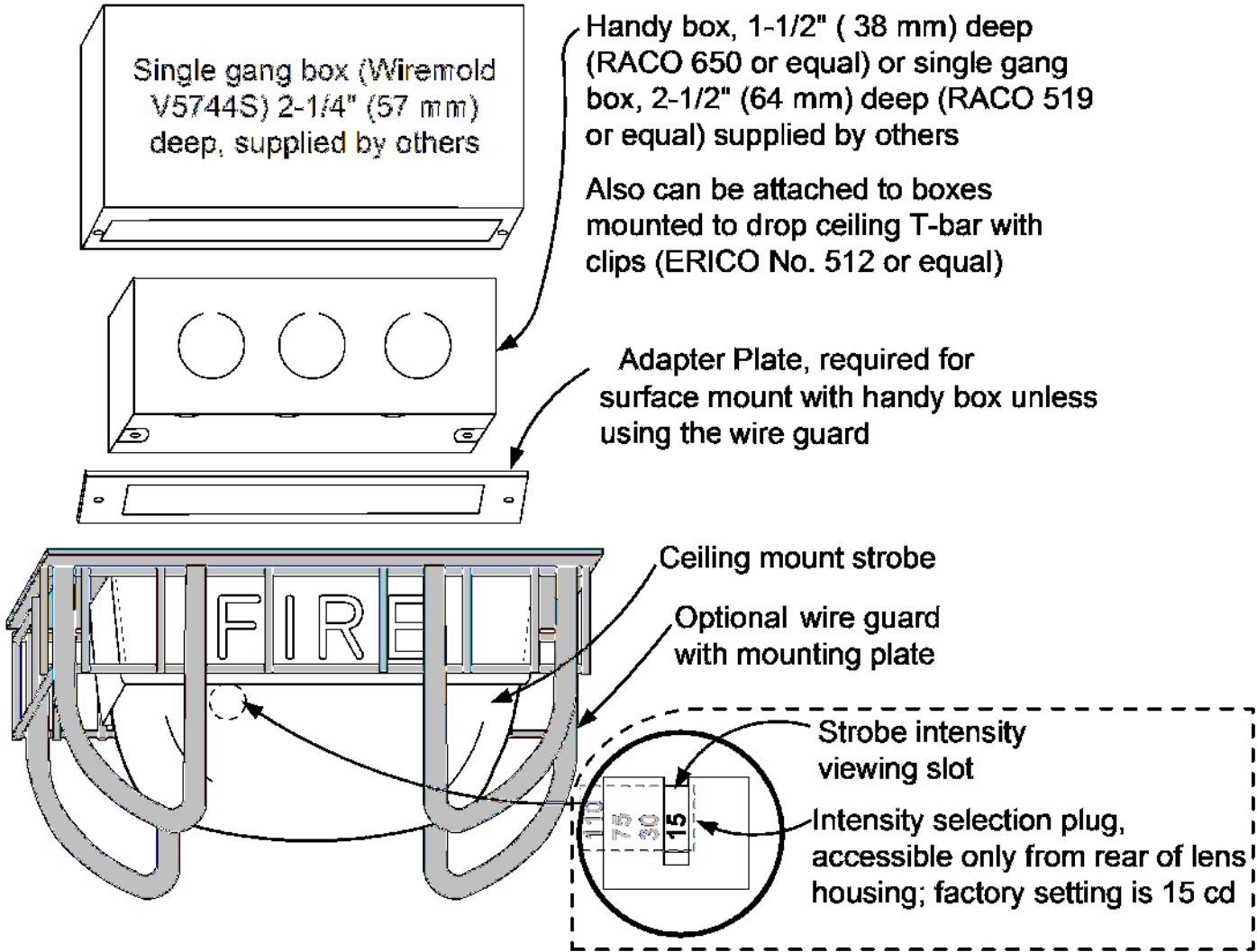

Note:

- 1. Figure shows 4905-9910 Adaptor Plate.
- 2. ** 4905-9926 Wire guard shown

Wall Mount Installation Reference; Adapter Plate, Guard, and Adapter Skirt

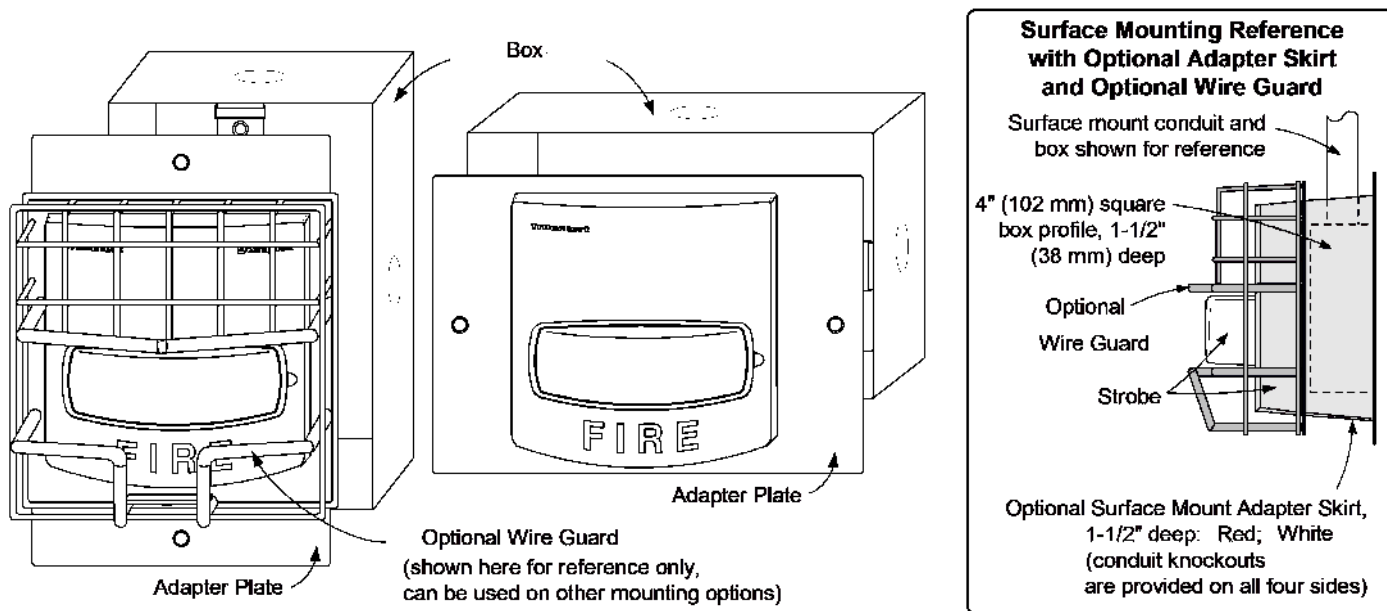

Figure 3: Wall Mount Installation Reference; Adapter Plate, Guard, and Adapter Skirt

Note:

Figure 3 shows:

- 4905-9931 Adapter Plate
- 2975-9145 Box
- 4905-9961 Optional Wire Guard
- Optional Surface Mount Adapter skirt:
 - Red: 4905-9937
 - White: 4905-9940

Features**Audible/visible (A/V) notification appliances with efficient electronic horn and high output xenon strobe, available for wall or ceiling mount**

- Operation is compatible with ADA requirements (refer to important installation information on page 3)
- Rugged, high impact, flame retardant thermoplastic housings are available in red or white with clear lens

Operates over a two-wire SmartSync circuit to provide:

- Horns that are controlled separately from strobes on the same two-wire circuit
- “On-until-silenced” and “on-until-reset” operation on the same two-wire pair
- SmartSync horn activation of Temporal pattern, March Time pattern (at 60 BPM), or on continuously
- Strobe appliances on the same circuit operating at a synchronized 1 Hz flash rate
- Class B operation requires connection to a compatible SmartSync NAC or to SmartSync Control Module (SCM) 4905-9938
- Class A operation when connected to the 4905-9938 SCM or with 4100U series fire alarm control panel NACs

Wall mount A/Vs features:

- Wiring terminals are accessible from the front of the housing providing easy access for installation, inspection, and testing
- Covers are available separately to convert housing color
- Available UL listed sound damper for locations requiring attenuation of 5 to 6 dBA (stairwells, small rooms, highly reverberant areas, etc.)

Optional adapters and wire guards:

- Wall mount A/V adapters are available to cover surface mounted electrical boxes and to adapt to Simplex® 2975-9145 boxes
- UL listed red wire guards are available for wall or ceiling mount A/Vs

Visible notification appliance (strobe):

- 24 VDC xenon strobe; intensity is selectable as 15, 30, 75, or 110 candela with visible selection jumper secured behind strobe housing
- UL listed to Standard 1971
- Regulated circuit design ensures consistent flash output and provides controlled inrush current

Audible notification appliance (horn):

- Low current, 24 VDC electronic horn with harmonically rich sound output suitable for either steady or coded operation (Temporal or 60 BPM March Time pattern)
- UL listed to Standard 464



Wall and Ceiling Mount A/Vs

Description

Multi-Candela TrueAlert A/Vs with horn and synchronized strobe provide convenient installation to standard electrical boxes. The enclosure designs are both impact and vandal resistant and provide a convenient strobe intensity selection. Since each model can be selected for strobe intensity output, on-site model inventory is minimized and changes encountered during construction can be easily accommodated.

Wall mount A/V housings are a one-piece assembly (including lens) that mounts to a single or double gang, or 4” square standard electrical box. The cover can be quickly removed (a tool is required) and covers are available separately for color conversion.

Ceiling mount A/Vs install using standard 4” electrical boxes. Color choice is determined by model number.

Strobe Intensity Selection

During installation, a selection plug at the back of the housing determines the desired strobe intensity. An attached flag with black letters on a highly visible yellow background allows the selected intensity to be seen at the side of the strobe lens.

* This product has been approved by the California State Fire Marshal (CSFM) pursuant to Section 13144.1 of the California Health and Safety Code. See CSFM Listing 7125-0026:317 for allowable values and/or conditions concerning material presented in this document. Accepted for use – City of New York Department of Buildings – MEA35-93E. Refer to page 2 for listing status of wire guards. Additional listings may be applicable; contact your local Simplex product supplier for the latest status. Listings and approvals under Simplex Time Recorder Co. are the property of Tyco Fire Protection Products.

Strobe Application Selection

Proper selection of visible notification is dependent on occupancy, location, local codes, and proper applications of: the *National Fire Alarm Code* (NFPA 72), ANSI A117.1; the appropriate model building code: BOCA, ICBO, or SBCCI; and the application guidelines of the Americans with Disabilities Act (ADA).

Synchronized Strobes

Multiple Strobes. When multiple strobes and their reflections can be seen from one location, synchronized flashes reduce the probability of photo-sensitive reactions as well as the annoyance and possible distraction of random flashing. The multi-candela strobes of these A/Vs are synchronized by the controlling SmartSync operation NAC.

Product Selection

Multi-Candela A/Vs

Model	Mounting	Housing Color	"FIRE" Lettering	Description
4906-9127	Wall	Red	White	Horn with Multi-Candela Strobe; strobe intensity selectable as: 15, 30, 75, or 110 candela; operates with SmartSync two-wire control
4906-9129		White	Red	
4906-9128	Ceiling	Red	White	
4906-9130		White	Red	

Wall Mount A/V Accessories

Model	Description	Dimensions
4905-9937	Red	Surface Mount Adapter Skirt; use to cover 1-1/2" (38 mm) deep surface mounted boxes 5-3/8" H x 5-1/4" W x 1-5/8" D (136 mm x 133 mm x 41 mm) depth with strobe = 4-3/8" (111 mm)
4905-9940	White	
4905-9931	Red Adapter Plate for mounting to Simplex 2975-9145 box (typically for retrofit, may be mounted vertical or horizontal)	8-5/16" x 5-3/4" x 0.060" Thick (211 mm x 146 mm x 1.5 mm)
2975-9145	Red Mounting Box, requires Adapter Plate 4905-9931	7-7/8" x 5-1/8" x 2-3/4" D (200 mm x 130 mm x 70 mm)
4905-9838	Optional Sound Damper; package of 20; field installed adhesive backed horn output attenuator; reduces output 5 to 6 dBA NOTE: After Sound Damper installation, measure sound level to ensure compliance with applicable code requirements	1-3/4" Diameter (44.5 mm) with 0.31" (8 mm) sound opening

SmartSync Control Module

Model	Description	Dimensions
4905-9938	SmartSync Control Module with Class B or Class A output; mounts in 4" (102 mm) square box; refer to data sheet S4905-0003 for details	4" x 4-1/8" x 1-1/4" D (102 mm x 105 mm x 32 mm)

Replacement Covers for Wall Mount A/Vs

Model	Description	Dimensions
4905-9994	Red cover with white "FIRE" lettering	5-1/8" H x 5" W x 1-1/2" D (130 mm x 127 mm x 38 mm)
4905-9995	White cover with red "FIRE" lettering	

Wire Guards and Ceiling Mount A/V Adapter

Model	Description	Dimensions
4905-9961*	Wall mount red wire guard with mounting plate, compatible with semi-flush or surface mounted boxes	6-1/16" H x 6-1/16" W x 3-1/8" D (154 mm x 154 mm x 79 mm)
4905-9927*	Red Wire Guard for mounting to flush mounted electrical box	8-1/2" x 6-1/8" x 3" (216 mm x 156 mm x 76 mm)
4905-9928*	Ceiling Mount Red Adapter Plate, required to mount guard to surface mounted electrical box	9" x 7" (229 mm x 178 mm)
4905-9915	White Surface Mount Adapter Box Extension, use to cover 1-1/2" deep surface mounted boxes	4-3/4" x 6-7/8" x 1-1/2" deep, (121 mm x 175 mm x 38 mm)
4905-9916		

* UL listed by Space Age Electronics Inc.

SmartSync Two-Wire Control

SmartSync operation mode allows a two-wire circuit to provide the ability to activate both the horn and strobe on the same NAC and then allow the horn to be silenced while the strobe remains flashing. The horn operates as "on-until-silenced" while the strobe operation is "on-until-reset."

SmartSync Control Sources

- **4006, 4007ES Hybrid, 4008, 4010, 4010ES, 4100ES, and 4100U Fire Alarm Control Panels** (refer to individual product data sheets for more information)
- **4009 IDNet NAC Extender** (refer to data sheet S4009-0002)
- **SmartSync Control Module (SCM) 4905-9938** (refer to data sheet S4905-0003)

Additional SmartSync compatible notification appliances include separate horns and combination horn/strobe notification appliances.

A/V Specifications

Wall Mount or Ceiling Mount, Common Specifications

Rated Voltage Range	UL Listed Rating	Regulated 24 DC; see Note 1 below					
	ULC Listed Rating	20 VDC to 30 VDC per ULC S526-M878					
Flash Rate and Synchronized NAC Loading	1 Hz; with up to 35 synchronized strobes maximum per NAC						
Environmental; Temperature and Humidity	32° to 122° F (0° to 50° C); 10% to 93%, non-condensing at 100° F (38° C)						
Connections	Terminal blocks for 18 AWG to 12 AWG (0.82 mm ² to 3.31 mm ²); two wires per terminal for in/out wiring						
Horn Output Characteristics	2400 to 3700 Hz sweep, modulated at 120 Hz rate						
Horn Output Ratings @ 10 ft (3 m) (see Note 2)	Voltage	16 VDC		24 VDC		33 VDC	
	Sound Type (see Note 2)	Steady	Coded	Steady	Coded	Steady	Coded
	UL 464 Reverberant Chamber	86 dBA	82 dBA	88 dBA	84 dBA	90 dBA	86 dBA
	Anechoic Chamber	92 dBA	91 dBA	94 dBA	95 dBA	96 dBA	96 dBA
Wall Mount	Housing Dimensions (with lens)	5-1/8" H x 5" W x 2-3/4" D (130 mm x 127 mm x 70 mm)					
	Maximum RMS Current Rating per Strobe Setting (see Note 3 below)	15 cd	30 cd	75 cd	110 cd		
		75 mA	116 mA	221 mA	285 mA		
	Reference RMS Currents at other voltages	18 VDC	67 mA	103 mA	196 mA	253 mA	
24 VDC		50 mA	77 mA	147 mA	190 mA		
Ceiling Mount	Housing Dimensions (with lens)	4-3/4 L" x 6-7/8" W x 2-5/8" D (121 mm x 175 mm x 67 mm)					
	Maximum RMS Current Rating per Strobe Setting (see Note 3 below)	15 cd	30 cd	75 cd	110 cd		
		86 mA	132 mA	250 mA	320 mA		
	Reference RMS Currents at other voltages	18 VDC	76 mA	117 mA	222 mA	284 mA	
24 VDC		57 mA	88 mA	167 mA	213 mA		

NOTES:

1. "Regulated 24 DC" refers to the voltage range of 16 to 33 VDC per UL Standard 1971, *Signaling Devices for the Hearing Impaired*. This voltage range is the absolute operating range. Operation outside of this range may cause permanent damage to the appliance. Please note that 16 VDC is the lowest operating voltage that is allowed at the last appliance on the NAC under worst case conditions.
2. Coded values are typical of the output measured with a Temporal coded or a March Time coded pulse and with a sound level meter reading on a "fast" setting. Under the same test conditions, coded horn output "peak" sound level readings are typically 4 dBA higher. Anechoic horn output ratings are typically more representative of actual installed sound output.
3. Currents are with horn on steady. The maximum RMS current listed is the device nameplate rating. Strobe designs are constant wattage and the maximum RMS current rating occurs at the lowest allowable operating voltage. (RMS is root mean square and refers to the effective value of a varying current waveform.)

Installation Reference, Surface or Semi-Flush Mounting

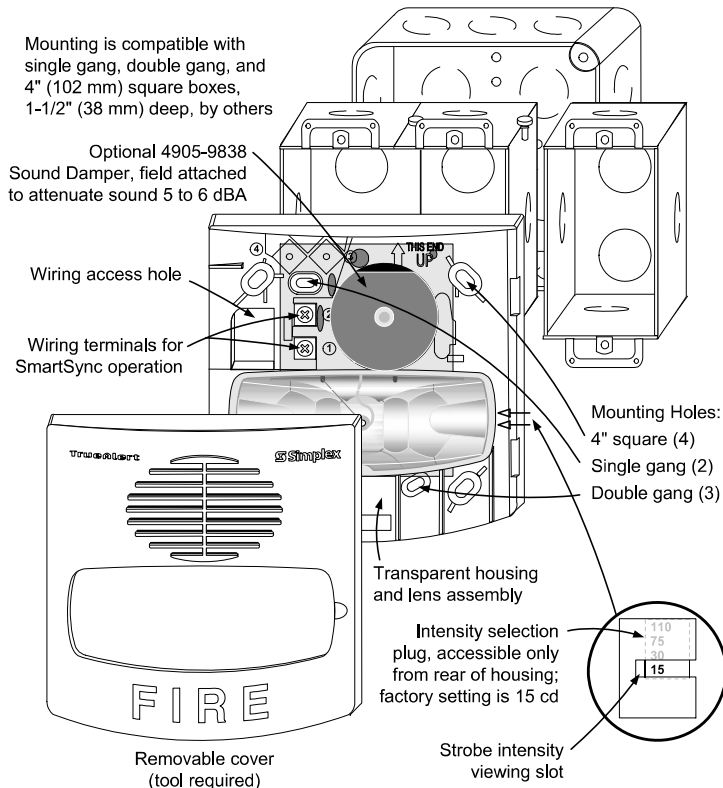

IMPORTANT! WALL MOUNT INSTALLATION HEIGHT REFERENCE

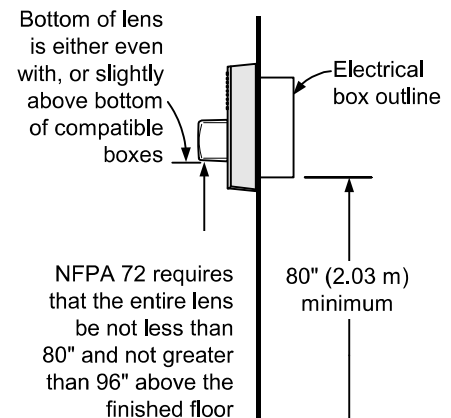

Ceiling Mount A/V and Guard Installation Reference

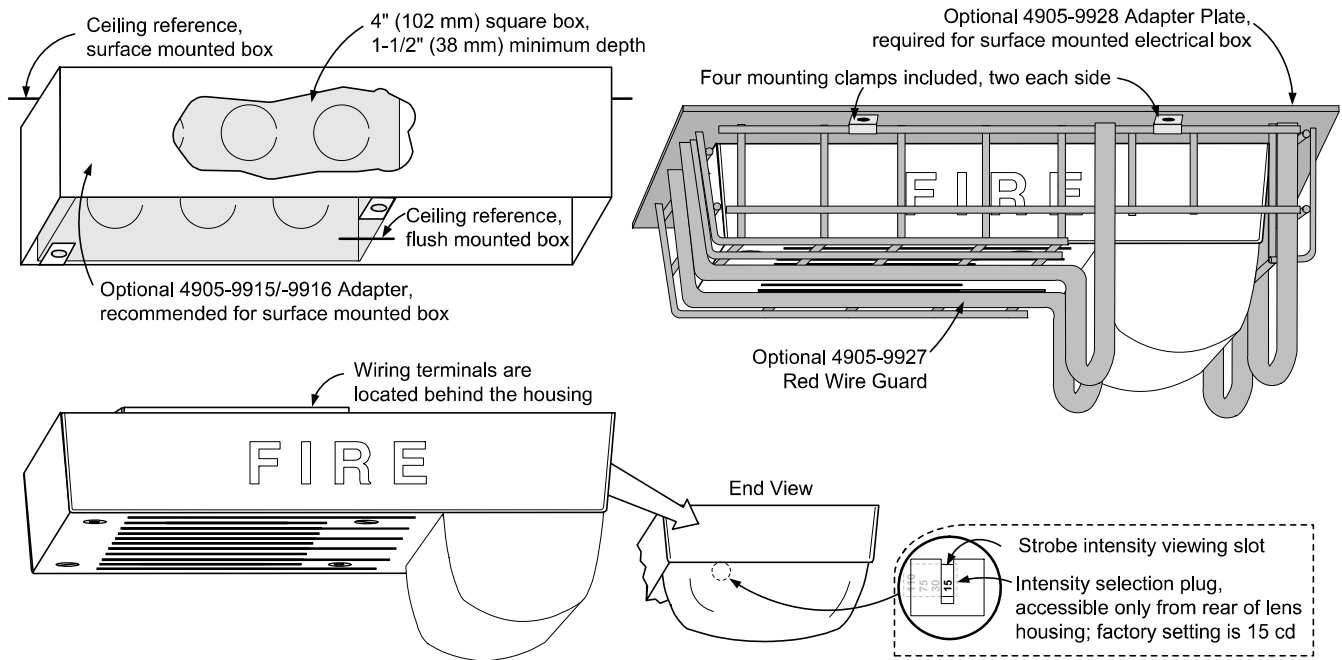

Wall Mount Installation Reference; Adapter Plate, Guard, and Adapter Skirt

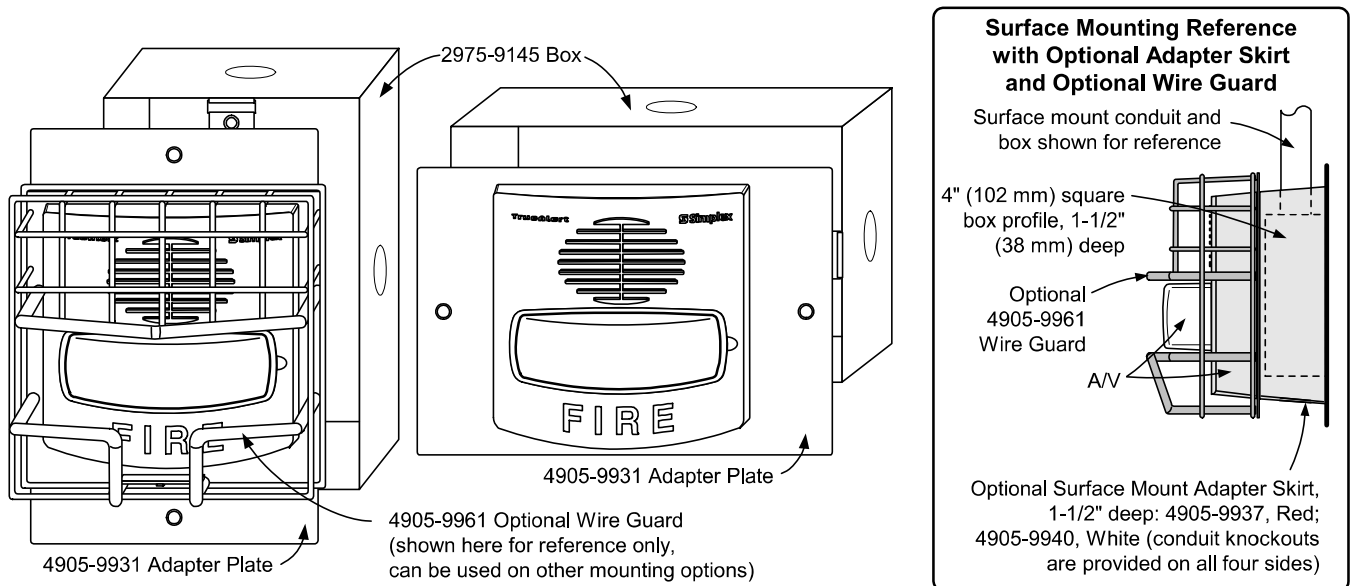

TYCO, SIMPLEX, and the product names listed in this material are marks and/or registered marks. Unauthorized use is strictly prohibited. NFPA 72 and National Fire Alarm and Signaling Code are registered trademarks of the National Fire Protection Association (NFPA).



Tyco Fire Protection Products • Westminister, MA • 01441-0001 • USA

S4906-0002-6 11/2014

www.simplex-fire.com

© 2014 Tyco Fire Protection Products. All rights reserved. All specifications and other information shown were current as of document revision date and are subject to change without notice.

Features

Provides additional notification appliance circuit (NAC) capacity with flexible operation modes and power-limited design

Four, Class B NACs are standard:

- Rated 2 A each for conventional reverse polarity 24 VDC notification appliances and providing multiple operation modes.
- Can be selected to provide synchronization for Simplex visible notification strobe flashes.
- Capable of controlling TrueAlert non-addressable notification appliances operating with SmartSync two-wire control mode.

Input control options:

- IDNet addressable communications from a 4007ES, 4010, 4010ES, 4100U, or 4100ES Fire Alarm Control Panel. See note.
- Or from one or two conventional 24 VDC NACs with multiple output control options

IDNet communications control benefits:

- Provides status monitoring and individual NAC control using a single address per 4009 IDNet NAC Extender
- Supports IDNet "Device Level" earth fault location

WALKTEST operation is available with either input choice

Internal 8 A power supply/battery charger:

- Charges internal batteries up to 12.7 Ah or up to 18 Ah batteries in external cabinet
- Provides status monitoring of battery, input power, and earth faults
- Rated 8 A for "Special Application" appliances; including 4901, 4903, 4904, and 4906 Series horns, strobes, horn/strobes, and speaker/strobes
- Rated 6 A for "Regulated 24 DC" appliance power

Optional 4009 IDNet NAC Extender modules:

- IDNet Communications Repeater provides Class B or Class A output
- IDNet Communications Fiber Optic Receiver/Repeater, available as Class B or Class X
- Four additional Class B NACs, rated 1.5 A for Special Application appliances; 1 A for Regulated 24 DC appliance power
- Class A, Two Circuit Adapter Module

UL Listed to Standard 864

External Accessories

IDNet communication fiber optic transmitters:

- For applications requiring the data integrity available with fiber optic communications
- Available as Class B or Class X
- Mounts in standard six-gang electrical box

External battery cabinet for 18 Ah batteries

Introduction

ADA compliance. Complying with the notification requirements of ADA (Americans with Disabilities Act) may require more notification appliance power than is available within the fire alarm control panel. When additional power is required, a 4009 IDNet NAC Extender can provide up to 8 A of NAC power with up to eight, supervised reverse polarity NACs.

Location flexibility. The 4009 IDNet NAC Extender can be mounted close to a compatible dedicated host panel or can be located remotely for convenient power distribution. Multiple operation modes and multiple connection options further increase location flexibility.

Additional information. For additional operation detail and application information, refer to *Installation Instructions 574-181* and *field wiring diagram 842-068*.

Note: 4100U requires revision 11 software or higher for compatibility. 4010 requires revision 2 software or higher for compatibility.

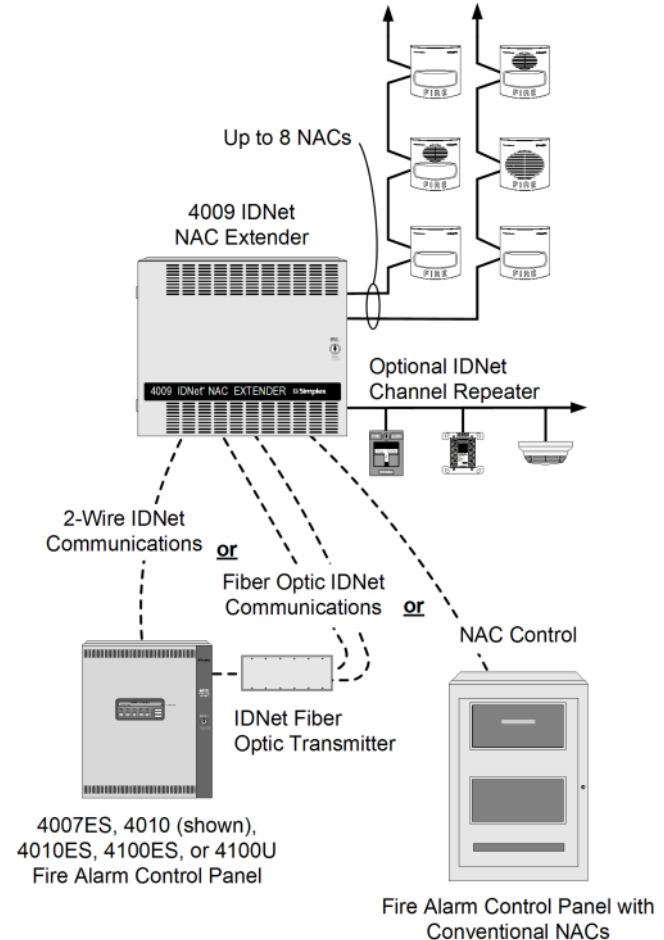

Figure 1: 4009 IDNet NAC Extender connection reference drawing

Application and operation information

IDNet addressable communications compatible. Up to 10, 4009 IDNet NAC Extenders can be controlled for each 4007ES, 4010ES, 4100U, or 4100ES IDNet communications channel; up to 5 can be controlled on the 4010 IDNet communications channel. Each output NAC can be individually controlled for general alarm or selective area notification requiring only one point address for each Extender. Individual Extender NACs can also be manually controlled from the host panel. IDNet controlled extenders will inform the host panel of troubles using IDNet communications. 4007ES, 4010ES, 4100ES, and 4100U control panels control using multi-point rules, refer to data sheet [S4090-0011](#) for details.

Optional IDNet repeaters. IDNet communications can be repeated with the optional IDNet Repeater Module or with the optional Fiber Optic Receiver Module. Up to 100 of the IDNet channel points can be repeated once (refer to [Typical IDNet connection example](#) and [4009 IDNet NAC Extender specifications](#) for details). Repeated IDNet communications also support the "device level" earth fault location utility of the host panel.

Hardware control applications. For applications where an existing (or new) conventional NAC needs additional power, the 4009 IDNet NAC Extender can be controlled directly from the NAC. Either one or two NACs, from either the same, or from different host fire alarm control panels, can be connected to control the 4009 IDNet NAC Extender output NACs. Multiple control selections provide flexible operation. (See [Hardware Control Connection Information](#) for more detail.) Alarms from the host panel will activate the four, 4009 IDNet NAC Extender NACs (or optionally, 8 NACs) to extend the alarm.

The 4009 IDNet Extender monitors itself and each of its output NACs for trouble conditions, including earth faults. Extenders wired to conventional NACs will indicate a trouble by opening the path to the NAC's end-of-line resistor, but retaining the ability to respond to alarms. Individual troubles are also annunciated by LEDs located on the 4009 IDNet NAC Extender main circuit board. Refer to [Service diagnostic features](#) for more diagnostic information.

Product selection

Table 1: Standard models

Model	Description	Comments
4009-9201**	120 VAC input	4009 IDNet NAC Extender with 4, Class B NACs and 8 A power supply
4009-9301	240 VAC input	
4009-9202CA (ULC listed model)	120 VAC input	
** 4009-9201 has been seismic tested and is certified to IBC and CBC standards as well as to ASCE 7 categories A through F, requires battery brackets as detailed on data sheet S2081-0019		

Table 2: Optional modules (for on-site installation)

Model	Description	Comments
4009-9807	Additional four point NAC module, rated 1.5 A Special Application appliances; 1 A for Regulated 24 DC appliance power, Class B	1 maximum
4009-9808	Dual Class A adapter (for two NAC outputs)	Select as required (4 maximum)
4009-9809	IDNet Repeater, output is Class A or Class B	Select either an IDNet Repeater or a Fiber Optic Receiver as required; one transmitter can connect to one receiver
4009-9810	Fiber Optic Receiver	Class B
4009-9811	Fiber Optic Receiver	Class A (IDNet), Class X (fiber)
4009-9805	Red Appliqué for door	Select if required
2975-9801	Semi-Flush Trim Kit	Beige trim
2975-9802	Semi-Flush Trim Kit	Red trim
		1 7/16 in. wide (78 mm), use if required for semi-flush installations

Table 3: Battery selection (select battery size using system requirements)

Model	Description	Comments
2081-9272	6.2 Ah Battery, 12 VDC	Two batteries are required, 24 VDC operation
2081-9274	10 Ah Battery, 12 VDC	
2081-9288	12.7 Ah Battery, 12 VDC	
2081-9275	18 Ah Battery, 12 VDC	Requires external battery cabinet, two batteries are required, 24 VDC operation

Table 4: External accessories (select using system requirements)

Model	Description	Comments
4090-9105	IDNet Fiber Optic Transmitter	Class B operation
4090-9107		Class X operation
		Mounts in six-gang electrical box, refer to 4090-9105/9107 IDNet fiber optic transmitter mounting information for mounting details
		Note: Class B Fiber Transmitter Rev C or higher, IS NOT COMPATIBLE with Class B Fiber Receiver before Rev J.
4009-9801	External battery cabinet for up to 18 Ah batteries, beige	16-1/4 in. W x 13-1/2 in. H x 5-3/4 in. D (413 mm x 343 mm x 146 mm)
4081 series	End-of-Line resistor harnesses; see data sheet S4081-0003 for details	

Typical IDNet connection example

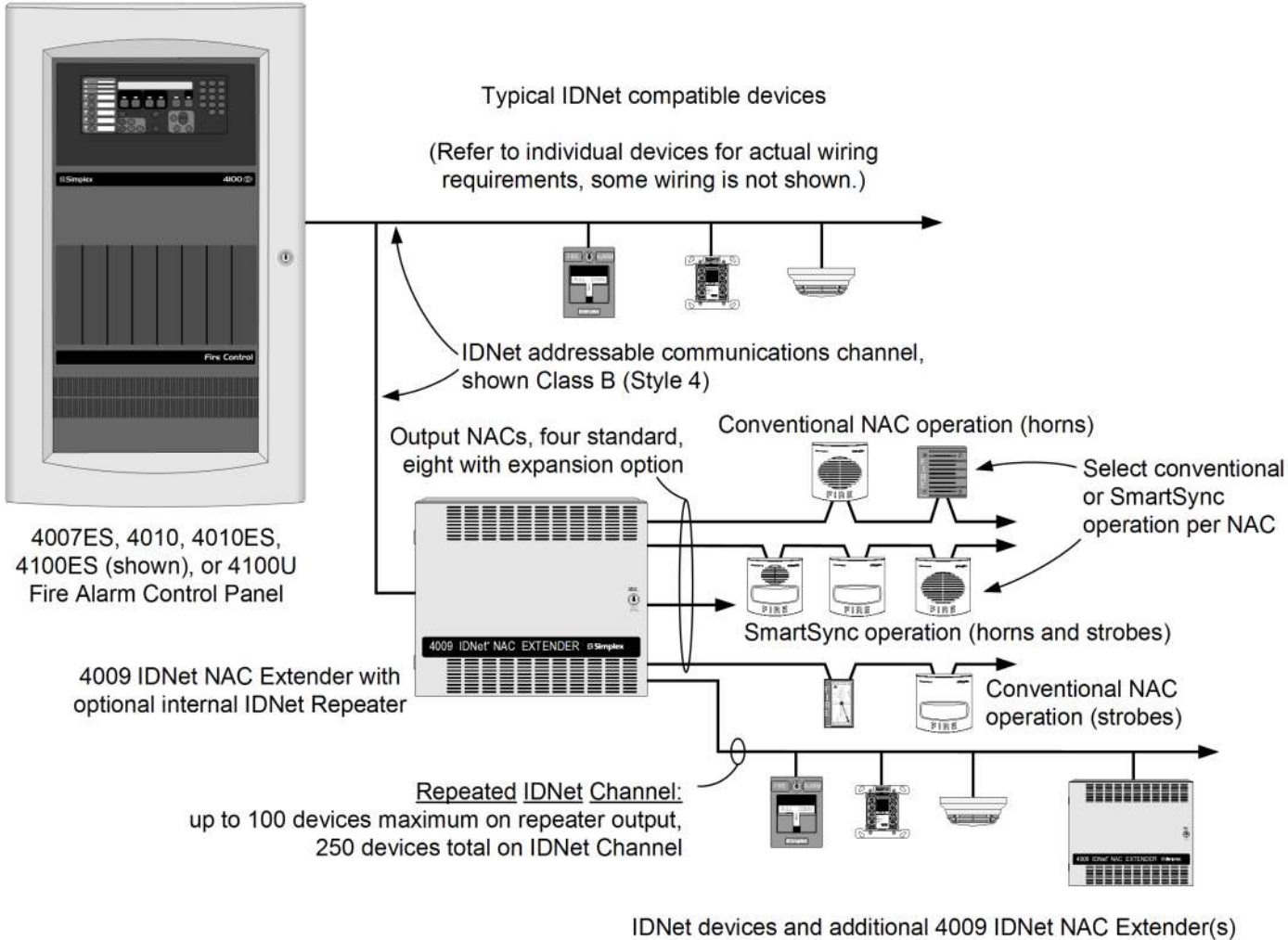

Figure 2: Typical IDNet connection example

Note: Up to 10 4009 IDNet NAC Extenders may be connected using 4007ES, 4010ES, 4100U, or 4100ES IDNet channel, up to 5 on the 4010 IDNet channel. IDNet communications can be repeated only once (can pass through only one series connected repeater or one fiber optic receiver).

Typical fiber optic system connections

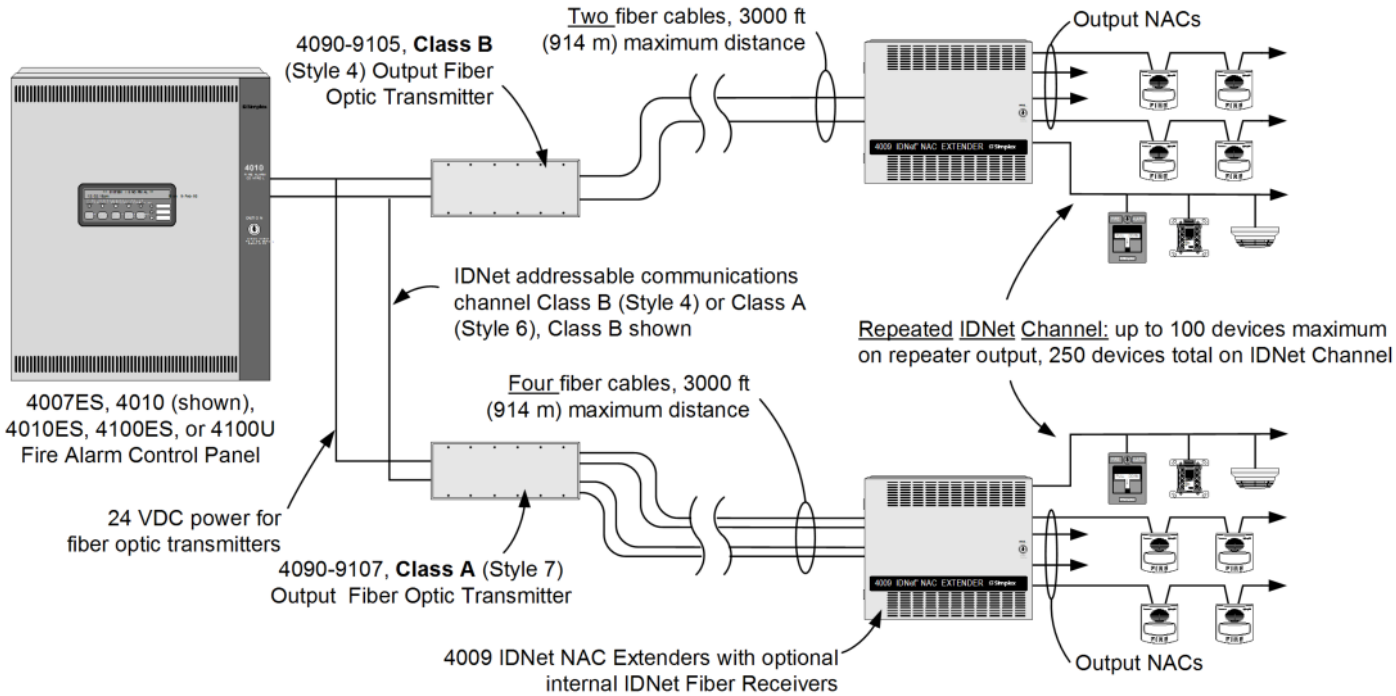

Figure 3: Typical fiber optic system connections

Note: Up to 10 4009 IDNet NAC Extenders may be connected per 4007ES, 4100ES, or 4010ES. Up to 5 4009 IDNet NAC Extenders may be connected on the 4010 IDNet channel. IDNet communications can be repeated only once (can pass through only one series connected repeater or one fiber optic receiver). Fiber optic transmitters connect to only one receiver in a 4009 IDNet NAC Extender.

Hardwire Control Connection Information

NAC Input Selections. The 4009 IDNet NAC Extender can be selected to:

- Track input NAC operation **or** to provide a locally generated code, selectable using NAC input.
- If selected for local coding, NAC outputs can be either **Temporal Coded** or **60 Beats/min March Time Coded**, one code selection per extender (input NACs must be on continuous with Alarm).
- Additionally, NAC outputs can be selected to provide the Simplex strobe synchronization signal. This signal will synchronize the flashes of synchronized strobes but will be ignored by free-run strobes and audible devices. (Strobes are for operation by noncoded NACs.)

NAC input to NAC output control can be selected for standard and optional NACs per the following table:

Table 5: Conventional NAC Output Operation Options

Input	A	B	C
NAC 1	NACs 1 and 2, 5 and 6	NACs 1 - 4	NACs 1 - 8
NAC 2	NACs 3 and 4, 7 and 8	NACs 5 - 8	-

Table 6: SmartSync NAC Output Operation

Input	NAC Control Function	
NAC 1	Strobe Control	All NAC outputs (1 - 8)
NAC 2	Horn Control	

SmartSync Notification Appliance Control

The **TrueAlert Notification Appliance** product line includes addressable and non-addressable operation. Non-addressable models are available with 2-wire SmartSync operation or conventional 4-wire operation. The following details apply to use with the 4009 IDNet NAC Extender:

- TrueAlert non-addressable models with SmartSync operation allow audible notification to be separately controlled over the same wire pair that controls visible notification.
- 4009 IDNet NAC Extenders can be selected to provide SmartSync operation whether controlled by IDNet communications or conventional NACs.
- IDNet control allows output NACs to be **individually selected** for conventional **or** SmartSync operation.
- With NAC input control, **all** output NACs are selected for either conventional **or** SmartSync operation.
- Refer to data sheet *S4009-0003* for TrueAlert Addressable operation details, contact your local Simplex product supplier for further information on specific TrueAlert notification appliances.

Hardwire control NAC connection one-line reference diagram

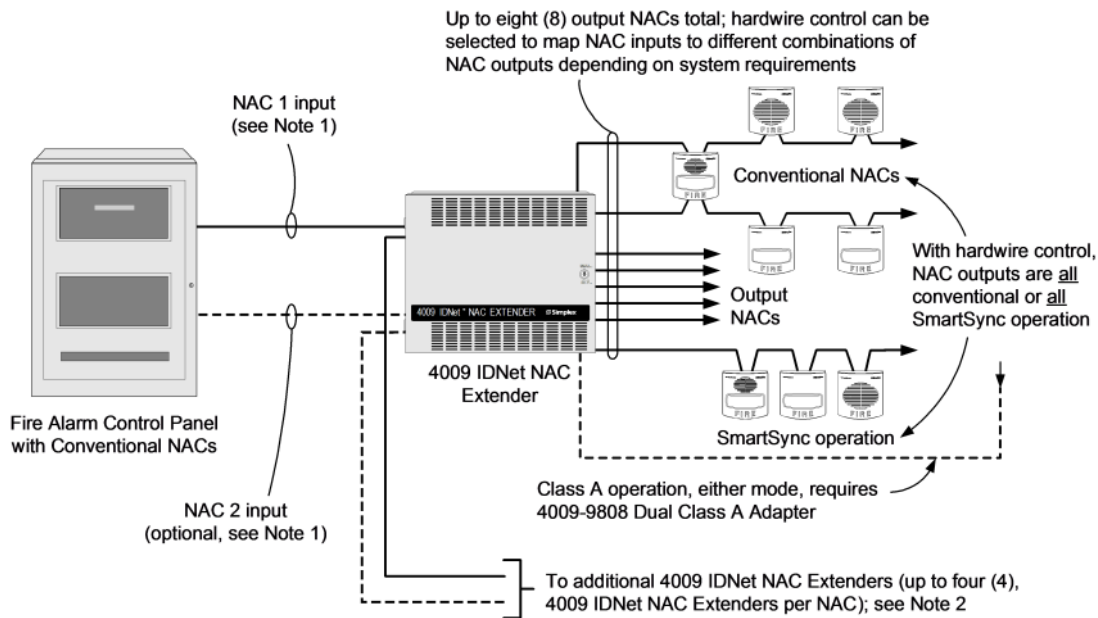

Figure 4: Hardwire control NAC connection one-line reference diagram

Note:

1. For separate audible and visible output NAC control, or SmartSync NAC output operation, 2 input NACs are required. NAC 1 is "on-until-reset" and NAC 2 is "on-until-silenced".
2. To synchronize strobe flash outputs for up to 4 4009 IDNet NAC Extenders, use the synchronized strobe output from a Synchronized Flash Module (4905-9914 for Class B operation, 4905-9922 for Class A operation) or, if available, from a NAC selected to provide synchronized strobe flash output. **NOTE: DO NOT USE a NAC selected for SmartSync operation for this function.**

Refer to Installation Instructions *574-181* for additional information and application guidance.

4009 IDNet NAC Extender specifications

Table 7: Input ratings

Specification	Rating
120 VAC input (4009-9201)	3A @ 102 VAC -132 VAC, 60 Hz
240 VAC input (4009-9301)	1.5A @ 204 VAC -264 VAC, 50 Hz /60 Hz
Hardwire control from external NACs; input requirements	Conventional reverse polarity operation
	5 mA maximum; 16 VDC to 33 VDC

Table 8: Output ratings

Specification	Rating
Total rating	8 A, Special application appliances 6 A, regulated 24 DC appliance power
Standard NACs	2 A each, special application or regulated 24 DC appliance power
Optional NACs (requires 4009-9807)	1.5 A each, Special Application appliances 1 A each, Regulated 24 DC appliance power
Special application appliances	Simplex non-addressable horns, strobes, and combination horn/strobes and speaker/strobes (contact your Simplex product representative for compatible appliances)
Regulated 24 DC appliances	Power for other UL listed appliances; use associated external synchronization modules where required
Strobe operation	Up to 33 strobes for each NAC can be synchronized; output NACs configured for Simplex synchronized strobe operation are synchronized to each other
Auxiliary output	500 mA @ 24 VDC nominal

Table 9: Optional modules ratings

Specification	Rating	
IDNet Repeater Module (4009-9809)	Input power	70 mA @ 24 VDC, system supplied
	IDNet input, one address	Maximum distance from IDNet source is 2,500 ft (762 m)
	IDNet output specifications	Repeated IDNet output for up to 100 devices (total IDNet devices not to exceed 250 for each channel)
		Maximum distance to farthest device is 2,500 ft (762 m)
		Total distance including "T-taps" is 10,000 ft (3048 m)
	Class A loop maximum distance is 2,500 ft (762 m), no "T" taps	

Table 10: Fiber optic receiver modules

Specification	Rating
Input current	4009-9810 , Class B, 65 mA @ 24 VDC, system supplied
	4009-9811 , Class X, 80 mA @ 24 VDC, system supplied
IDNet output specifications	Same as those for repeater module
Fiber optic transmission distance	3000 ft (914 m) maximum

Table 11: General specifications

Specification	Rating
Operating temperature	32° F to 120° F (0° C to 49° C)
Operating humidity range	10% to 90% RH from 32° F to 104° F (0° C to 40° C)
Wiring Connections*	Terminal blocks for 18 AWG (stranded) to 12 AWG (solid)
Note: * Metric wire equivalents: 18 AWG = 0.82 mm ² ; 12 AWG = 3.31 mm ²	

Fiber optic transmitter specifications

Table 12: Fiber optic transmitter specifications

Specification	Rating
Input voltage	18.9 VDC -32 VDC from compatible listed fire alarm supply
Input current	4090-9105, Class B, 30 mA @ 24 VDC
	4090-9107, Class X, 35 mA @ 24 VDC
Fiber optic connections and cable requirements	Multimode, graded index, 50/125µm, 62.5/125 µm, 100/40 µm, or 200 µm
	Type ST connectors
	4090-9105, Class B operation, two fiber cables required 4090-9107, Class X operation, four fiber cables required
Module size (with mounting bracket)	6-13/16 in. W x 3-3/4 in. H x 1-1/8 in. D (173 mm x 95 mm x 29 mm)
On-board status indicators	Green LED flashing = transmit
	Red LED flashing = receive
	Separate red LED on 4090-9107 = Class X receive
Communications	Simplex IDNet
Fiber optic transmission distance	3000 ft (914 m) maximum
Wiring connections*	Terminal blocks for 18 AWG (stranded) to 12 AWG (solid)
Operating humidity	10% to 90% RH from 32° F to 104° F (0° C to 40° C)
Operating temperature	32° F to 120° F (0° C to 49° C)
* Metric wire equivalents: 18 AWG = 0.82 mm ² ; 12 AWG = 3.31 mm ²	

4009 IDNet NAC Extender mounting and module placement information

Additional four point module shown model 4009-9807 .

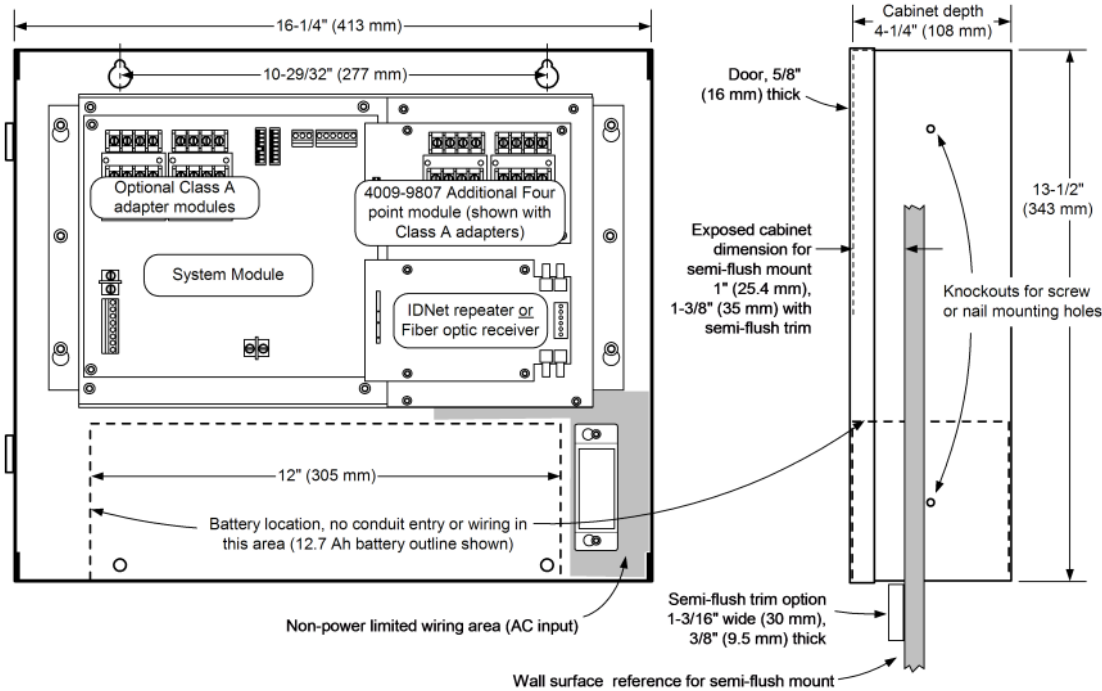

Figure 5: 4009 IDNet NAC Extender mounting and module placement information

Note: Recommended conduit entrance varies with module selection. Refer to general installation instructions 574-181, specific module installation instructions, and to field wiring diagrams 842-068 before locating conduit entrance.

4009 IDNet NAC extender cabinet with door detail

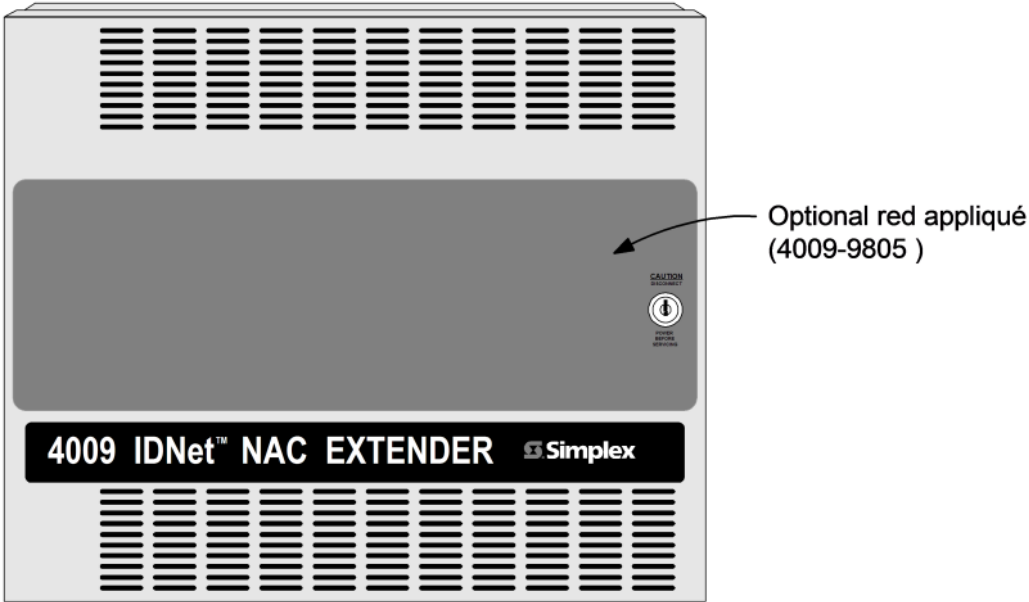
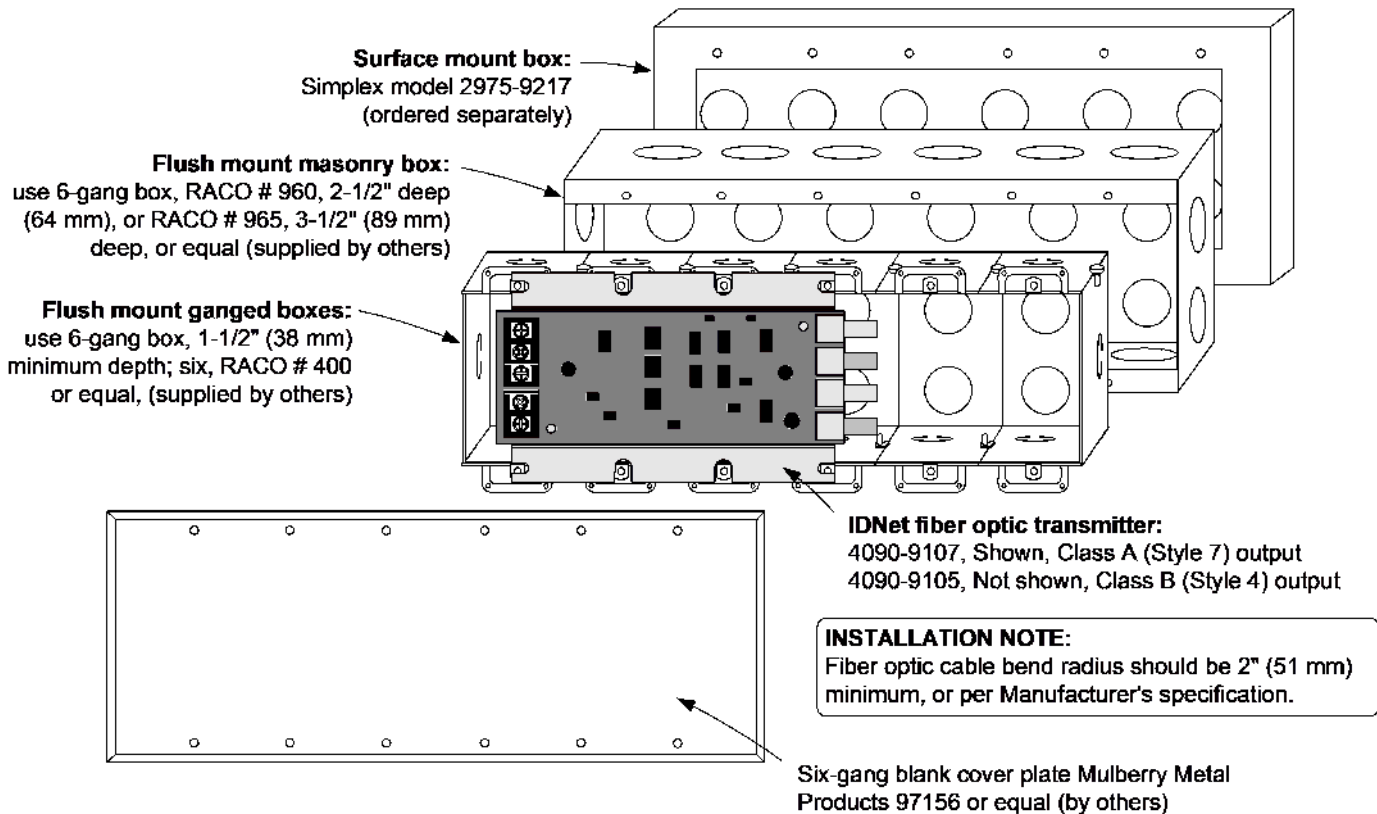

Figure 6: 4009 IDNet NAC extender cabinet with door detail

4090-9105/9107 IDNet fiber optic transmitter mounting information



Service diagnostic features

Power-up self-diagnostics. Upon power-up, the 4009 IDNet NAC Extender tests each module and performs earth fault diagnostics. Trouble conditions are communicated to the host control panel and are also displayed on diagnostic status LEDs in the 4009 IDNet NAC Extender. When connected via IDNet communications, detailed status information is available at the host. When controlled with conventional NAC inputs, common troubles are signaled by providing a polarized open circuit that disconnects the NAC wiring from its end-of-line resistor but still allows a reversed polarity alarm to be received.

Door mounted reference label. The 4009 IDNet NAC Extender has a detailed programming and diagnostic label inside the front door that provides a quick reference for both installation and checkout.

LED Status Indicators are provided for the following:

- **Each NAC** (standard and optional) has a dedicated yellow LED that:
 - During supervision provides a slow flash to indicate a short circuit condition and a fast flash to indicate an open circuit.
 - During an alarm, the LED follows the NAC output (on steady or flashing with coded output).
- **Four, general status yellow LEDs** provide nine separate indications listed in priority of urgency. As a trouble is eliminated, any remaining trouble will then be indicated until the 4009 IDNet NAC Extender is returned to normal operation.
- **AC power status** is indicated by a green LED that is on when AC is normal. During low AC (brownout) conditions or with no AC, the LED is off. Additional power and battery status is indicated by the general status LEDs.

4009 IDNet NAC extender current calculation chart
Step 1. Calculate the basic extender battery requirements (minus NAC loads)
Panel, NAC Options, and Auxiliary Power (underlined model numbers are optional modules).

Model	Description	Supervisory current	Actual supervisory	Alarm current	Actual alarm
4009-9201	120 VAC input	Basic Panel	85 mA	185 mA	185 mA
4009-9301	240 VAC input				
4009-9807	Additional four point NAC	40 mA	+ _____	40 mA	+ _____
4009-9808	Dual class A adapter (no additional current)	-	-	-	-
Auxiliary power output		(500 mA maximum)	+ _____	(500 mA maximum)	+ [A1] _____
Basic panel supervisory current			= [S1] _____		
Basic panel alarm current					= [A2] _____

Step 2. Calculate IDNet output module and device current (if used)

4009-9809	IDNet Repeater	Select one for each extender	70 mA	+ _____	70 mA	+ _____
4009-9810 *	Fiber Optic Receiver, Class B		65 mA		65 mA	
4009-9811 *	Fiber Optic Receiver, Class X		80 mA		80 mA	
IDNet devices (connected to repeater or receiver above), 0.7 mA each, maximum of 100			Total devices x 0.7 mA each	+ _____	Total devices x 0.7 mA each	+ _____
Note: IDNet Fiber Optic Transmitter current is supplied from the host fire alarm control panel		IDNet module supervisory current		[S2] = ____		
		IDNet module alarm current				= [A3] _____
				Maximum available current		= 8 A*
<u>Step 2. Calculate available NAC current</u>				Subtract auxiliary power output		- [A1] _____
				Subtract IDNet module current		- [A3] _____
* 8 A for special application appliances; 6 A for regulated 24 DC appliances				Available NAC current		= [A4] _____

Step 3. Calculate actual NAC loading (Limited to available NAC current per Step 2.)

NAC type	NAC circuit #	NAC alarm current
Standard panel NACS , 2 A maximum for each NAC	Circuit 1	+ _____
	Circuit 2	+ _____
	Circuit 3	+ _____
	Circuit 4	+ _____
Optional four point NAC module , 1.5 A maximum special application rating, 1 A maximum regulated 24 DC rating, per NAC	Circuit 5	+ _____
	Circuit 6	+ _____
	Circuit 7	+ _____
	Circuit 8	+ _____
Total actual NAC load alarm current		= [A5] _____

Step 4. Calculate total supervisory current
Total supervisory current = Basic panel current [S1] + IDNet Module current [S2] = _____

Step 5. Calculate total alarm current
Total alarm current = Basic panel current [A2] + IDNet module current [A3] + actual NAC Current [A5] = _____

Features

Rechargeable, sealed lead-acid batteries

- Lead-calcium grid structure with immobilized electrolyte in absorbent separator
- Low maintenance with no need to add water
- Low self-discharge characteristics
- One-piece, high-impact polystyrene cell cover with high-reliability dual-seal construction
- UL 924 recognized pressure relief valves

Battery sizes

- Batteries for internal mounting from 6.2 Ah to 50 Ah
- Larger batteries, up to 110 Ah, for mounting in external battery cabinets. Models with internal chargers are available.

Battery cabinets with chargers

Battery cabinets with chargers communicate with their connected fire alarm control unit (FACU) and are available for 4100ES/4010ES/4100U Series and 4010 Series FACUs.

Description

Simplex rechargeable sealed-lead acid batteries provide reliable and repeatable discharge and recharge characteristics for use in fire alarm and other systems applications. They feature immobilized electrolyte in an absorbent separator, which provides rated capacity on the first cycle. Because of their sealed construction, packaging is possible within the system electronics enclosure, see Figure 3. When this is applicable, the quantity of system cabinets and the battery wiring distances are minimized. Where required, external battery cabinets can be close-nipped to the FACU to house larger batteries with battery chargers available in some battery cabinet sizes.

Battery details

Charging: Compatible with Simplex battery chargers.

Series connections: Connect the batteries in series to produce 24 V system voltage. Battery sets must be of identical voltage, model number, appearance, and have approximately the same date of manufacture for optimal operation.

Testing: Test battery capacity with a sealed lead-acid battery tester to withdraw a minimum of battery charge. Testing is available through your local Simplex product supplier.

Shipping: Sealed lead-acid batteries only ship by ground or sea transportation.

Disposal: Battery chemicals and materials can be recycled. Refer to information shipped with the battery or on its case. Return to the manufacturer or to a similarly qualified battery processing facility for proper disposal.

Seismic activity applications: Battery brackets are available for systems tested for compliance with specific batteries. Refer to data sheet *S2081-0019* for details.

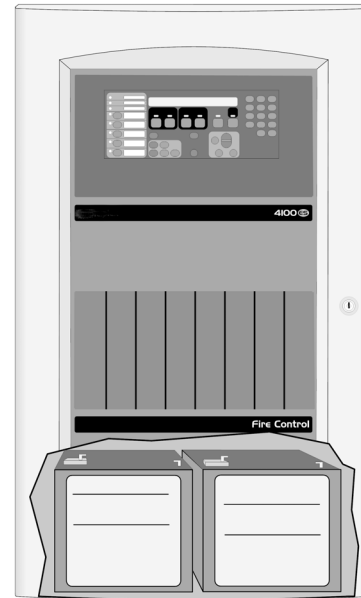

Figure 1: Compatible sealed lead-acid batteries inside an FACU cabinet

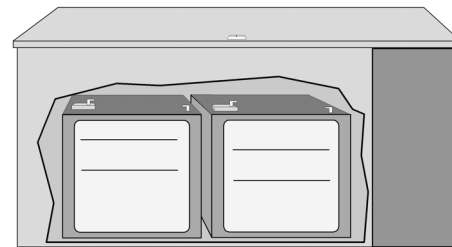

Figure 2: A remote battery cabinet for larger battery requirements

* Refer to page 4 for battery charger and cabinet agency listings. The batteries detailed in this document meet the requirements of UL, ULC, and Factory Mutual for use with respective equipment battery chargers as listed below. Contact your local Simplex product supplier for proper battery selection per system requirements. Listings and approvals under Simplex Time Recorder Co. are the property of Tyco Fire Protection Products.

Battery construction reference

Actual appearance varies with battery size.

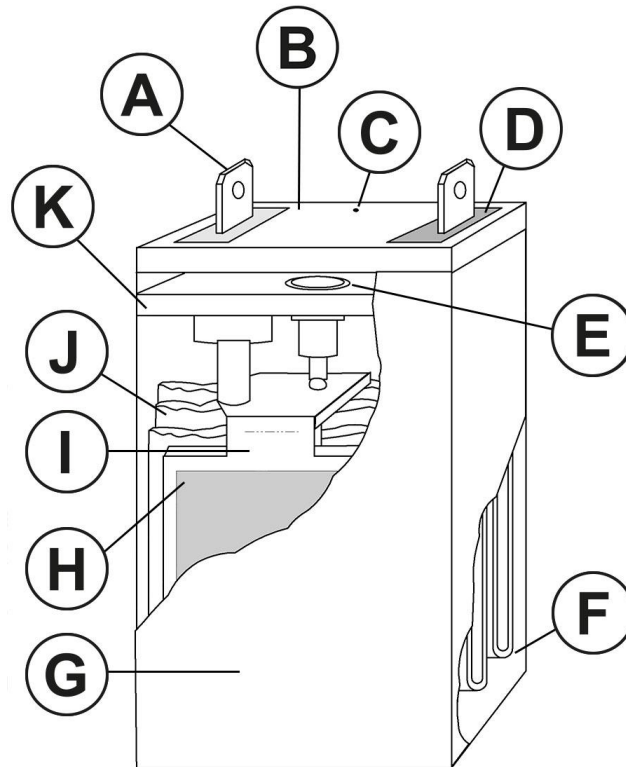

Figure 3: Battery construction reference

Callout	Description	Callout	Description
A	Quick connect or post type terminal. Type varies with battery size.	B	Sealed outer cover
C	Vent hole	D	Potting material, black for negative, red for positive. Polarity is also clearly marked with + and -.
E	Pressure relief valve	F	Semi-permeable membrane separator
G	Cell case, high impact polystyrene	H	Lead-calcium grids
I	Cell group	J	Absorbent separator used to immobilize electrolyte
K	Inner cover	-	-

Battery size specifications

Battery model	Capacity at 20 hour discharge rate	Width*	Depth*	Height with terminals	Approximate weight*
2081-9272	6.2 Ah	6.12 in. (156 mm)	2.65 in. (68 mm)	4 in. (102 mm)	5.75 lb (2.6 kg)
2081-9286	7.0 Ah	6.12 in. (156 mm)	2.65 in. (68 mm)	4 in. (102 mm)	5.75 lb (2.6 kg)
2081-9274	10 Ah	6 in. (153 mm)	4.06 in. (103 mm)	4 in. (102 mm)	9.2 lb (4.2 kg)
2081-9288	12.7 Ah	6 in. (153 mm)	4 in. (102 mm)	4 in. (102 mm)	9 lb (4.1 kg)
2081-9275	18 Ah	7.25 in. (184 mm)	3.38 in. (86 mm)	6.63 in. (168 mm)	14.3 lb (6.5 kg)
2081-9287	25 Ah	6.63 in. (168 mm)	5 in. (127 mm)	7 in. (178 mm)	19.4 lb (8.8 kg)
2081-9271 (rectangular case, typically for service)	33 Ah	12.5 in. (318 mm)	3.38 in. (86 mm)	7.06 in. (179 mm)	26.6 lb (12.1 kg)
2081-9276 (square case, use for new)	33 Ah	7.75 in. (197 mm)	5.25 in. (133 mm)	6.75 in. (171 mm)	26.5 lb (12 kg)
2081-9296	50 Ah	9 in. (229 mm)	5.5 in. (140 mm)	8.88 in. (225 mm)	41.8 lb (19 kg)
2081-9279	110 Ah	11.38 in. (289 mm)	10.5 in. (267 mm)	9 in. (230 mm)	82 lb (37 kg)

* Dimensions and weight are per battery and are for reference only. Exact size may vary. Refer to [Battery compatibility for FACU mounting](#) and [External battery cabinet compatibility reference](#) for mounting compatibility. Batteries are 12 V each and connected in series for 24 V system use.

Note: When wired in series for 24 V output, these batteries are to be of identical voltage, appearance, model number, and have approximately the same date of manufacture.

General battery specifications

Specifications	
Nominal Voltage Rating	12 V
Discharge Rating	20 hour rate
Typical Charge/Discharge Cycles	100 cycles to 150 cycles
Preferred Charge Temperature Range	60°F to 90°F (15.6°C to 32.2°C)

Battery compatibility for FACU mounting

Note: Refer to individual FACU product data sheets for additional battery application information.

Table 1: Battery compatibility for FACU mounting

Simplex FACU model series										
Battery Model	Capacity	4003EC	4004R	4007ES & 4005	4006 & 4008	4009 (all models)	4010	4010ES	4100ES/4100U	4100 & 4120 (2, 4 or 6-Unit)
2081-9272	6.2 Ah	Yes	Yes	Yes	Yes	Yes	Yes	Yes	Yes	Yes
2081-9286	7.0 Ah	Yes	Yes	Yes	Yes	Yes	Yes	Yes	Yes	Yes
2081-9274	10 Ah	Yes	Yes	Yes	Yes	Yes	Yes	Yes	Yes	Yes
2081-9288	12.7 Ah	Yes	Yes	Yes	Yes	Yes	Yes	Yes	Yes	Yes
2081-9275	18 Ah	Ext	Note 3	Yes	Ext	Ext	Note 2	Yes	Yes	Yes
2081-9287	25 Ah	Ext	Note 3	Ext	Ext	N/A	Yes	Yes	Yes	Yes
2081-9271 rectangular	33 Ah	Ext	Note 3	Ext	N/A	N/A	Note 3	Yes	Yes	Ext
2081-9276 square	33 Ah	Ext	Note 3	N/A	N/A	N/A	Note 3	Yes	Yes	Yes
2081-9296	50 Ah	N/A	Note 3	N/A	N/A	N/A	Note 3	Note 4	2 or 3 bay	Ext
2081-9279	110 Ah	Requires external battery cabinet, compatible with 4100ES, 4010ES, 4100, and 4120 Series only								

Yes = Compatible with included FACU cabinet.

Ext = Requires external battery cabinet, refer to [External battery cabinet specification reference](#).

Note:

- These batteries meet the requirements of UL, ULC, and Factory Mutual for use with respective equipment battery chargers listed above. Contact your local Simplex product supplier for proper battery selection per system requirements.
- 4010 Cabinets accommodate 2081-9275, 18 Ah batteries, but do not allow bottom entry conduit.
- Use 4081 series companion cabinet and charger, refer to [External battery cabinet specification reference](#).
- For two bay cabinets only, 50 Ah batteries will fit in the cabinet.

External battery cabinet compatibility reference

Table 2: External battery cabinet compatibility reference

Battery cabinets without chargers, connected to FACU charger							
Cabinet	Panel compatibility	Battery					
		2081-9275 18 Ah*	2081-9287 18 Ah*	2081-9271 Rectangular 33 Ah	2081-9276 Square 33 Ah	2081-9296 50 Ah	2081-9279 110 Ah
2081-9280	4100ES, 4010ES, 4100U, and 4100+	N/A	N/A	N/A	N/A	N/A	Yes
2081-9281	multiple	Yes	Yes	Yes	Yes	Yes	N/A
2081-9282		Yes	Yes**	N/A	Yes	N/A	N/A
4009-9801	multiple	Yes	Yes**	N/A	Yes	N/A	N/A

Table 3: External battery cabinet compatibility reference

Battery cabinets with chargers							
Cabinet	Panel compatibility	Battery					
		2081-9275 18 Ah*	2081-9287 18 Ah*	2081-9271 Rectangular 33 Ah	2081-9276 Square 33 Ah	2081-9296 Square 50 Ah	2081-9279 110 Ah
4081-9301	4004R and 4010	Yes	Yes	Yes	Yes	Yes	N/A
4081-9302		Yes	Yes	Yes	Yes	Yes	Yes
4081-9306	4100ES, 4010ES and 4100U	N/A	N/A	N/A	N/A	Yes	Yes
4081-9308		N/A	N/A	N/A	N/A	Yes	Yes

* Batteries smaller than those listed are normally mounted in the product cabinet

** 25 AH capacity is effective as of 7/2005

Yes = Compatible with included FACU cabinet

External battery cabinet specification reference

Table 4: Battery cabinets without chargers, shallow design with front door

Model	Color	Listings	Description		Dimensions
2081-9281	Beige	UL and CSFM	2-Unit, 4100 style cabinet without charger; with locking solid door and battery shelf, primarily for use with 50 Ah batteries		25.75 in. W x 20.75 in. H x 6.75 in. D (654 mm x 527 mm x 171 mm)
2081-9282	Red	UL			
4003-9860*	Beige	FM	For use with 4003EC systems, for batteries up to 33 Ah (refer to 4003EC data sheet S4003-0002)		9.5 in. H x 24 in. W x 9 in. D (241 mm x 610 mm x 229 mm)
4009-9801*	Beige	UL, ULC, and FM	For batteries up to 33 Ah	External battery cabinet without charger, with locking solid door and battery harness; for close-nippled mounting to FACU cabinet	16.25 in. W x 13.5 in. H x 5.75 in. D (413 mm x 343 mm x 146 mm)*

* Depth increased for 2081-9276 square 33 Ah batteries effective 7/2005.

Table 5: Battery cabinet without charger, deep design with hinged lid

Model	Color	Listings	Description	Dimensions
2081-9270	Red	UL	Battery cabinet without charger; cabinet has vented front, and hinged lid with support rod and lock on top	26.5 in. W x 12 in. H x 12 in. D (673 mm x 305 mm x 305 mm)

Table 6: Chargers for use with 4010 FACUs and 4004R suppression release systems, refer to data sheet S4081-0001

Model	Color	Listings	Input voltage	Description	Dimensions
4081-9301	Beige	UL and FM	120 VAC	Battery cabinet with charger for the 4010 and 4004R FACU, for batteries up to 50 Ah, with front door	22.5 in. W x 16.75 in. H x 8.38 in. D (572 mm x 425 mm x 213 mm)
4081-9302	Red				

Table 7: Battery cabinet without charger for 110 Ah batteries, for use with compatible FACU mounted chargers, refer to data sheet S2081-0012

Model and listing	Color	Listings	Cabinet description	Compatible chargers	Charger description	Dimensions
2081-9280	Red	UL, ULC, CSFM	Battery cabinet without charger for 2081-9279, 110 Ah batteries. Includes 80 A battery fuse, terminals and battery connection cables. See data sheet for details.	4100-9xxx Series	4100ES/4100U Power Supplies for Master Controller/CPU Bays	26.5 in. W x 12 in. H x 12 in. D (673 mm x 305 mm x 305 mm)
				4100-5401	4100ES Additional ES Power Supply (ES-PS)	
				4100-5111 4100-5113	4100ES/4100U Additional SPS	
				4100-5311 4100-5313	4100ES Additional EPS+	
				4100-5325 4100-5327	4100ES Additional EPS	
				4100-5125 4100-5127	4100ES/4100U Remote Power Supply (RPS)	
				4100-5120 4100-5122	4100ES/4100U TrueAlert Addressable Power Supply (TPS)	
				4100-0104 4100-0114 4100-0124	4100 legacy power supplies	

Table 8: Battery cabinet with charger for 110 Ah batteries, for use with compatible FACU mounted chargers, refer to data sheet S2081-0012

Model	Color	Listings	Input voltage	Description	Dimensions
4081-9306	Red	UL, ULC, FM, MEA (NYC)	120 VAC	Battery cabinet with charger for batteries up to 110 Ah	27.88 in. W x 13.5 in. H x 14.63 in. D (708 mm x 343 mm x 371 mm)
4081-9308	Red	UL, ULC, FM	220/230/240 VAC, multi-tapped		
4100-9837	Green LED Power-on Indicator Kit, required for ULC listing, mounts above access panel using knockout provided				



DTK-TSS4D

Series Connected Surge Protector

DITEK's DTK-TSS4D provides total surge protection solutions for addressable and conventional alarm systems.

The DTK-TSS4D protects dedicated 120VAC power circuits that feed control panels and other critical equipment. It includes dry contacts for remote notification of surge protection status and EMI/RFI filtering to ensure clean power for connected equipment.



Product Features

- Series design for fast response and best level of protection
- Multi-stage hybrid circuit design
- Diagnostic LED provides positive indication of system power and SPD function
- Form C dry contacts for remote monitoring
- UL1283 EMI/RFI Filtering
- UL Listed NEMA 4X enclosure

Applications

- Fire Alarm Panels
- Control Panels
- 120Vac Single Phase Critical Loads
- Applications where a UL Listed SPD is required

Technical Specifications

Voltage Configuration:	120VAC Single Φ
MCOV:	150V
Protection Modes:	All Modes (L-G, L-N, N-G)
Voltage Protection Rating:	600V L-G, L-N 1000V N-G
Surge Current Rating:	50,000 Amps
Max. Continuous Current:	20 Amps
SCCR:	10kA
Nominal Discharge Current Rating (I_n):	3kA
EMI/RFI Filtering Attenuation:	Up to 35dB, 100kHz – 100MHz

Mechanical Specifications

Connection Method:	Hardwired, series configuration
Housing:	Polycarbonate NEMA 4X (IP66) UL94 Flammability Rating
Operating Temperature:	32°F – 140°F (0°C – 40°C)
Maximum Humidity:	95% non-condensing
Dimensions:	9.5" L X 6.25" W x 3.63" H (241 mm x 159 mm x 92 mm)
Weight:	1.8 lb (0.45 kg)

Quality Standards & Approvals

Certifications:	UL1449 4 th Edition cUL, UL1283
SPD Type:	Type 2
Standards Compliance:	IEEE C62.41.1 –2 and C62.45
Warranty:	10 Year Limited Warranty

