



**Fire Marshal Division**  
P.O. Box 370  
Lillington, NC 27546  
910-893-7580

Reviewed for Fire Code Compliance



Leslie Jackson

07/29/2024 9:12:42 AM

## Application for Plan Review

Permit Type: \_\_\_\_\_

Date Received: \_\_\_\_\_ Received By: \_\_\_\_\_

Name of Project: \_\_\_\_\_

Physical Address of Project: \_\_\_\_\_

Plans Submitted By: \_\_\_\_\_

Project Phone: (\_\_\_\_\_) - \_\_\_\_ - \_\_\_\_

Contact Person/Address: \_\_\_\_\_

\_\_\_\_\_

Contact Phone: (\_\_\_\_\_) - \_\_\_\_ - \_\_\_\_ (\_\_\_\_\_) - \_\_\_\_ - \_\_\_\_

Contractor's Name/Info: \_\_\_\_\_

\_\_\_\_\_

Contractor's Phone: (\_\_\_\_\_) - \_\_\_\_ - \_\_\_\_

Contact Email: \_\_\_\_\_

- **Plans that are submitted will be reviewed as quickly as possible with an average time of review between 7-10 working days.**
- **Status checks may be conducted on plan reviews by visiting the website <http://hteweb.harnett.org/Click2GovBP/Index.jsp> or by calling the Harnett County Central Permitting Office (910-893-7525 : Opt. 2), or the Harnett County Fire Marshal's Office (910-893-7580).**
- **Approved plans must be picked up from the Central Permitting Office and all fees paid before any required inspections can be conducted.**

PROJECT: HARNETT CO COMMONS, HEALTH, SO

PROJECT NUMBER: 24:650557841

LOCATION: LILLINGTON, NC

# FIRE ALARM SYSTEM

DATE: 06-26-2024

Submitted By:



540 Civic Boulevard, Suite 105  
Raleigh, NC 27610

919-279-6400  
FAX 919-279-6439

Sales Rep: Stephen Sander

Prepared by: Joe Simmons





**Node 1**

| <b>QTY</b> | <b>MODEL NUMBER</b> | <b>DESCRIPTION</b>              |
|------------|---------------------|---------------------------------|
| 1          | 4100-9701           | ES-PS MSTR CTRLR 2X40           |
| 1          | 41002153            | 3Bay Glass Dr Pkg Factory Only  |
| 1          | 41007905            | FACTORY BUILT-MAIN CONFIGURED   |
| 1          | 4100-2300           | EXPANSION BAY (PHASE 10 ONLY)   |
| 1          | 4100-2504           | CS GATEWAY W/IIP COM 4100 SIDE  |
| 1          | 4100-6104           | ESNET NTWK INTERFACE CARD SLOT  |
| 1          | 4100-3117           | MSTR CTRLR IDNET2, FACTORY ONLY |
| 2          | 4100-6307           | ES NET DSL MEDIA CARD           |
| 1          | 4100-5450           | NAC CARD                        |
| 1          | 4100-0644           | 120V ES-PS PDM HARNESS          |
| 1          | 4100-0634           | POWER DISTRIBUTION MODULE 120V  |
| 1          | 4100-1294           | LED/SWITCH SLIDE-IN LABEL KIT   |
| 1          | 4603-9101           | LCD ANNUNCIATOR                 |
| 1          | 4100-5131           | ES-PS FAN MODULE                |
| 1          | 4100-1284           | 8 SW, 16 RED/GREEN LED MODULE   |
| 1          | 4100-3209           | 8 PT 3A AUX RELAY CARD          |
| 1          | 4100-1288           | 64/64 LED/SWITCH CONTROLLER     |
| 7          | 4100-1279           | 2 BLANK DISPLAY MODULE          |
| 1          | 4100-2302           | 8 SLOT EXP BAY FILLER PANEL     |

**Node 1 Equipment**

| <b>QTY</b> | <b>MODEL NUMBER</b> | <b>DESCRIPTION</b>             |
|------------|---------------------|--------------------------------|
| 1          | 2975-9446           | 3 BAY BB/GDOOR/DRESS PNL PLAT  |
| 1          | DTK-TSS4D           | 1.5kVA Uninterruptible Power S |
| 2          | 2081-9287           | BATTERY 25AH                   |
| 35         | 4098-9714           | PHOTO SENSOR                   |
| 5          | 4098-9733           | HEAT SENSOR                    |
| 40         | 4098-9792           | SENSOR BASE                    |
| 5          | 4099-9006           | STATION-LED, DA PUSH ADDR      |
| 4          | 4098-9755           | DUCT SENSOR HOUSING            |





|   |           |                               |
|---|-----------|-------------------------------|
| 4 | 4098-9856 | "SAMPLING TUBE 49"', PLASTIC" |
| 4 | 2098-9806 | REMOTE TEST STATION           |
| 4 | 4090-9002 | RELAY IAM                     |
| 4 | 4090-9802 | COVER-ADDRESS MODULE SURFACE  |

**Node 2**

| QTY | MODEL NUMBER | DESCRIPTION                     |
|-----|--------------|---------------------------------|
| 1   | 4100-9701    | ES-PS MSTR CTRLR 2X40           |
| 1   | 41002153     | 3Bay Glass Dr Pkg Factory Only  |
| 1   | 41007905     | FACTORY BUILT-MAIN CONFIGURED   |
| 1   | 4100-2300    | EXPANSION BAY (PHASE 10 ONLY)   |
| 1   | 4100-2504    | CS GATEWAY W/IP COM 4100 SIDE   |
| 1   | 4100-6104    | ESNET NTWK INTERFACE CARD SLOT  |
| 1   | 4100-3117    | MSTR CTRLR IDNET2, FACTORY ONLY |
| 1   | 4100-3110    | IDNET2+2 250 POINT 4 LOOP MOD   |
| 1   | 4100-5450    | NAC CARD                        |
| 2   | 4100-6307    | ES NET DSL MEDIA CARD           |
| 1   | 4100-0644    | 120V ES-PS PDM HARNESS          |
| 1   | 4100-0634    | POWER DISTRIBUTION MODULE 120V  |





|   |           |                               |
|---|-----------|-------------------------------|
| 1 | 4100-1294 | LED/SWITCH SLIDE-IN LABEL KIT |
| 1 | 4603-9101 | LCD ANNUNCIATOR               |
| 1 | 4100-5131 | ES-PS FAN MODULE              |
| 1 | 4100-1284 | 8 SW, 16 RED/GREEN LED MODULE |
| 1 | 4100-3209 | 8 PT 3A AUX RELAY CARD        |
| 1 | 4100-1288 | 64/64 LED/SWITCH CONTROLLER   |
| 7 | 4100-1279 | 2 BLANK DISPLAY MODULE        |
| 1 | 4100-2302 | 8 SLOT EXP BAY FILLER PANEL   |

**Node 2 Equipment**

| <b>QTY</b> | <b>MODEL NUMBER</b> | <b>DESCRIPTION</b>             |
|------------|---------------------|--------------------------------|
| 1          | 2975-9446           | 3 BAY BB/GDOOR/DRESS PNL PLAT  |
| 1          | DTK-TSS4D           | 1.5kVA Uninterruptible Power S |
| 2          | 2081-9287           | BATTERY 25AH                   |
| 74         | 4098-9714           | PHOTO SENSOR                   |
| 9          | 4098-9733           | HEAT SENSOR                    |
| 83         | 4098-9792           | SENSOR BASE                    |
| 14         | 4099-9006           | STATION-LED, DA PUSH ADDR      |
| 4          | 4098-9755           | DUCT SENSOR HOUSING            |
| 4          | 4098-9856           | "SAMPLING TUBE 49"', PLASTIC"  |
| 4          | 2098-9806           | REMOTE TEST STATION            |
| 4          | 4090-9002           | RELAY IAM                      |
| 4          | 4090-9802           | COVER-ADDRESS MODULE SURFACE   |







**Node 3**

| QTY | MODEL NUMBER | DESCRIPTION                     |
|-----|--------------|---------------------------------|
| 1   | 4100-9701    | ES-PS MSTR CTRLR 2X40           |
| 1   | 41002153     | 3Bay Glass Dr Pkg Factory Only  |
| 1   | 41007905     | FACTORY BUILT-MAIN CONFIGURED   |
| 1   | 4100-2300    | EXPANSION BAY (PHASE 10 ONLY)   |
| 1   | 4100-2504    | CS GATEWAY W/IP COM 4100 SIDE   |
| 1   | 4100-6104    | ESNET NTWK INTERFACE CARD SLOT  |
| 1   | 4007-6416    | GSM CELLULAR MODULE 4G/LTE      |
| 1   | 4007-6407    | GSM 50' ANTENNA KIT, 3G/2G      |
| 1   | 4100-3117    | MSTR CTRLR IDNET2, FACTORY ONLY |
| 1   | 4100-3110    | IDNET2+2 250 POINT 4 LOOP MOD   |
| 1   | 4100-5450    | NAC CARD                        |
| 2   | 4100-6307    | ES NET DSL MEDIA CARD           |
| 2   | 4100-0644    | 120V ES-PS PDM HARNESS          |
| 1   | 4100-0634    | POWER DISTRIBUTION MODULE 120V  |
| 1   | 4100-1294    | LED/SWITCH SLIDE-IN LABEL KIT   |
| 1   | 4603-9101    | LCD ANNUNCIATOR                 |
| 1   | 4100-5131    | ES-PS FAN MODULE                |
| 1   | 4100-5401    | ES-PS POWER SUPPLY              |
| 1   | 4100-1284    | 8 SW, 16 RED/GREEN LED MODULE   |
| 2   | 4100-3209    | 8 PT 3A AUX RELAY CARD          |
| 1   | 4100-1288    | 64/64 LED/SWITCH CONTROLLER     |
| 7   | 4100-1279    | 2 BLANK DISPLAY MODULE          |
| 1   | 4100-2302    | 8 SLOT EXP BAY FILLER PANEL     |





**Node 3 Equipment**

| <b>QTY</b> | <b>MODEL NUMBER</b> | <b>DESCRIPTION</b>             |
|------------|---------------------|--------------------------------|
| 1          | 4009-9201           | NAC EXTENDER 120VAC, IDNET     |
| 2          | 2081-9287           | BATTERY 25AH                   |
| 2          | 2081-9288           | BATTERY 12.7AH                 |
| 1          | 2975-9446           | 3 BAY BB/GDOOR/DRESS PNL PLAT  |
| 2          | DTK-TSS4D           | 1.5kVA Uninterruptible Power S |
| 115        | 4098-9714           | PHOTO SENSOR                   |
| 15         | 4098-9733           | HEAT SENSOR                    |
| 130        | 4098-9792           | SENSOR BASE                    |
| 10         | 4099-9006           | STATION-LED, DA PUSH ADDR      |
| 16         | 4098-9755           | DUCT SENSOR HOUSING            |
| 16         | 4098-9856           | "SAMPLING TUBE 49"', PLASTIC"  |
| 16         | 2098-9806           | REMOTE TEST STATION            |
| 22         | 4090-9002           | RELAY IAM                      |
| 22         | 4090-9802           | COVER-ADDRESS MODULE SURFACE   |



## Features

4100ES Cabinets are available with one, two, or three bays.

Figure 1: 4100ES two-bay cabinet with ES Touch Screen Display



### Master controller bay, top

- Models available with Color ES Touch Screen Display as shown in Figure 1, Monochrome 2 line x 40 Character Display
- 32-Bit Master Controller with color-coded operator interface including raised switches for high-confidence feedback
- Dual configuration program CPU, convenient service port access, and capacity for up to 3000 addressable points
- CPU assembly includes 2 GB dedicated compact flash memory for on-site system programming and information storage
- ES Power Supply (ES-PS) and charger with onboard alarm relay, programmable auxiliary power output and provisions for one 4 in. x 10 in. or two 4 in. x 5 in. compatible option cards such as IDNet2 addressable device interface, Conventional NAC or Addressable IDNAC SLC modules. For additional details refer to *ES-PS and ES-XPS Installation Instructions 579-1288*.
- Existing control panels have upgrade kits available.

### Network compatibility

Compatible with Simplex ES Net or 4120 Fire Alarm Networks.

### Standard addressable interfaces

- 250 point addressable IDNet 2 SLC channel with electrically isolated dual short circuit isolating loops that supports TrueAlarm analog sensors and IDNet communications monitoring and control devices
- Remote annunciator module support through RUI+ (remote unit interface) communications port.

### Optional modules

- Building Network Interface Module (BNIC) for Ethernet connectivity options, refer to data sheet *S4100-0061*

- Electrically isolated output two-loop IDNet 2 and four-loop IDNet 2+2 modules with short circuit isolation output loops allowing use with either shielded or unshielded, twisted or untwisted single pair wiring
- Fire Alarm Network Interfaces, DACTs, city connections, and up to five RS-232 ports for printers and terminals
- Compatible with Connected Services Gateway to support central station communication and enable SafeLINC Cloud Services, refer to datasheet *S2080-0091*
- MAPNET II addressable device modules and MAPNET II quad isolator modules
- IDNAC signalling line circuits (SLCs) for addressable appliance control
- Alarm relays, auxiliary relays, additional power supplies, IDC modules, NAC expansion modules
- Service modems, VESDA Air Aspiration Systems interface, ASHRAE BACnet Interface, TCP/IP Bridges
- LED/switch modules and panel mount printers
- Emergency communications systems (ECS) equipment, 8 channel digital audio or 2 channel analog audio
- 8-point zone/relay module, each point is selectable as an IDC input or relay output. Class A IDCs require two points (one out and one return). Relays rated for 2 A at 30 VDC (resistive) and configurable as either normally open or normally closed.
- Compatible with Simplex remotely located 4009 IDNet NAC Extenders, up to ten for each IDNet SLC.

### Listings information\*

- UL 864, Fire Detection and Control (UOJZ), Smoke Control Service (UUKL), Releasing Device Service (SYZV), Emergency Communication and Relocation Equipment (UOQY)
- UL 1076, Proprietary Alarm Units - Burglar (APOU)
- UL 2017, Process Management Equipment (QVAX), Emergency Alarm System Control Units (FSZI)
- UL 1730, Smoke Detector Monitor (UULH)
- UL 2572, Mass Notification Systems (PGWM)
- CAN/ULC-S527 Control Units for Fire Alarm Systems (UOJZ7), Releasing Device Service (SYZV7)
- CAN/ULC-S559 Central Station Fire Alarm System Units (DAYR7)
- ULC/ORD-C1076 Proprietary Burglar Alarm Units and Systems (APOU7)
- ULC/ORD-C100 Smoke Control System Equipment (UUKL7)

### Software feature summary

#### CPU provides dual configuration programs

- Two programs ensure optimal system protection and commissioning efficiency with one active program and one reserve.
- The system reduces downtime by remaining operational during download.

#### PC based programmer features

- Convenient front panel accessed Ethernet port for quick and easy download of site-specific programming.
- You can upload or download modifications for greater service flexibility.
- The software downloads firmware enhancements to the onboard flash memory.

#### Operator interface features

- TrueAlarm individual analog sensing with front panel information and selection access.
- **Dirty** TrueAlarm sensor maintenance alerts, service and status reports including **almost dirty**.
- TrueAlarm magnet test indication appears as a distinct **test**

\* See module information sections for product that is UL or ULC listed and additional listing information. This product has been listed by the California State Fire Marshal (CSFM) pursuant to Section 13144.1 of the California Health and Safety Code. See CSFM Listing 7165-0026:251(4100ES) for allowable values and/or conditions concerning material presented in this document. Accepted for use – City of New York Department of Buildings – MEA35-93E. At the time of publication only UL and ULC listings are applicable to ES Net network products. Additional listings may be applicable; contact your local Simplex product supplier for the latest status

**abnormal** message when in test mode.

- TrueAlarm sensor peak value performance report.
- Operators can use **Install Mode** to group multiple troubles for uninstalled modules and devices into a single trouble condition, typical with future phased expansion. With future equipment and devices grouped into a single trouble, operators can more clearly identify events from the commissioned and occupied areas.
- Module level ground fault searching assists installation and service by locating and isolating modules with grounded wiring.
- **Recurring Trouble Filtering** allows the panel to recognize, process, and log recurring intermittent troubles, such as external wiring ground faults, but only sends a single outbound system trouble to avoid nuisance communications.
- **WALKTEST** silent or audible system test performs an automatic self-resetting test cycle.

### Introduction

4100ES Series Fire Detection and Control Panels provide extensive installation, operator, and service features with point and module capacities suitable for a wide range of system applications. An onboard Ethernet port provides fast external system communications to expedite installation and service activity. Dedicated compact flash memory archiving provides secure on-site system information storage of electronic job configuration files.

### Modular design

A wide variety of functional modules are available to meet specific system requirements. Operators can use selections to configure panels for either Stand-Alone or Networked fire control operation. InfoAlarm Command Center options provide convenient expanded display content, detailed on data sheet *S4100-1045*.

### Module Bay description

**The Master Controller Bay** (top) includes a standard multi-featured ES power supply, the master controller board, expansion space for optional features, and operator interface equipment.

**The Expansion Bays** include a Power Distribution Interface (PDI) for new 4 in. x 5 in. flat design option modules and also accommodate 4100-style modules.

**The Battery Compartment** (bottom) accepts two batteries, up to 50 Ah, to be mounted in the cabinet without interfering with module space. Figure 2 identifies bay locations using a three bay cabinet for reference.

Figure 2: 4100ES Module Bay reference

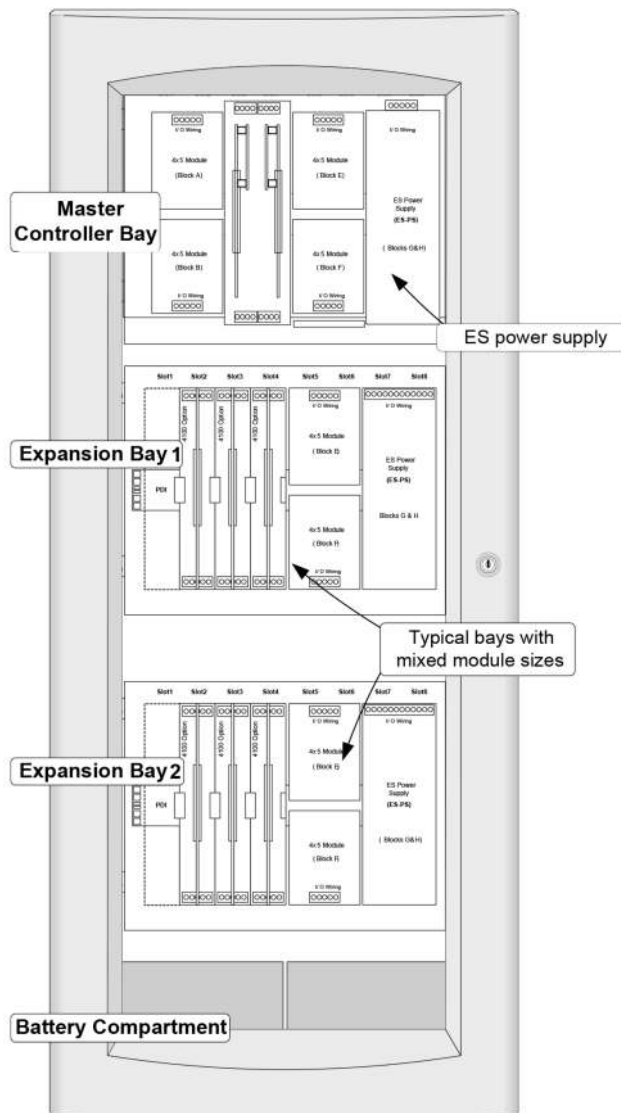

## Mechanical description

- Boxes can be close-nippled. Each box provides convenient stud markers for drywall thickness and nail-hole knockouts for quicker mounting.
- Smooth box surfaces are provided for locally cutting conduit entrance holes exactly where required.
- The latching dress panel (retainer) assembly easily lifts off for internal access.
- NACs can be mounted directly on power supply assemblies providing minimized wiring loss, compact size, and readily accessible terminations.
- Packaging supports traditional 4100-style motherboard with daughter cards.
- Modules are power-limited except as noted, such as relay modules.
- The NEMA 1/IP30 box is ordered separately and available for early installation.
- Doors are available with tempered glass inserts or solid. Boxes and doors are available in platinum or red.
- Boxes and door/retainer assemblies are ordered separately for each system requirements. Refer to data sheet *S4100-0037* for details.

## Operator interface detail reference

4100ES Fire Alarm Control Units are provided with either an enhanced Color ES Touch Screen Display or a basic Monochrome 2 Line by 40 Character operator interface depending on the model selected. The following illustrations highlight the primary functions of each.

Figure 3: ES Touch Screen Display interface

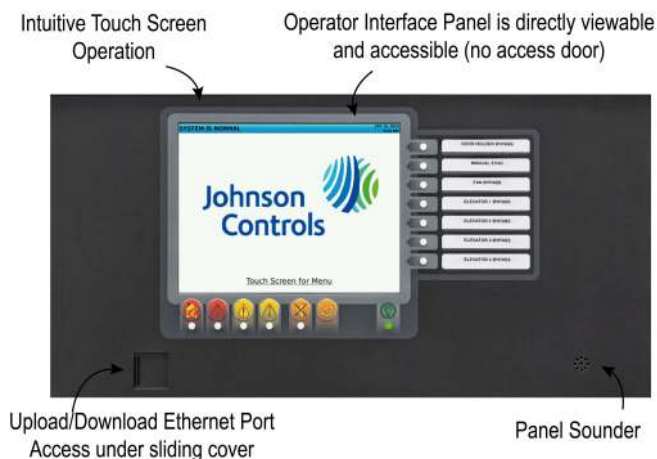
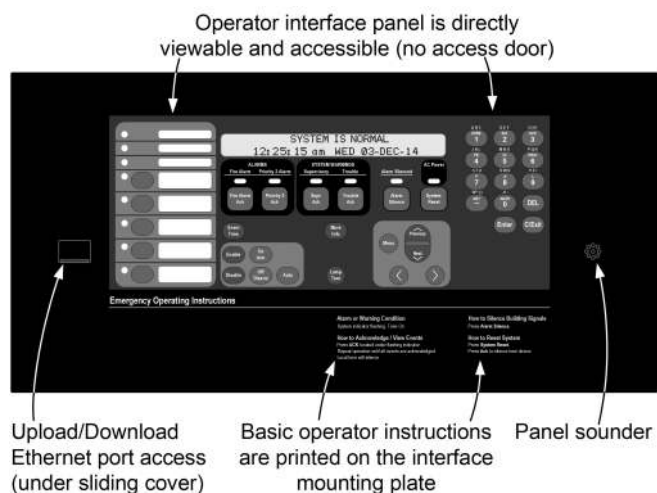

Figure 4: 2 x 40 Operator interface



## Compatible peripheral devices

The 4100ES is compatible with an extensive list of remote peripheral devices including printers, CRT/keyboards (up to five total), and both conventional and addressable devices including TrueAlarm analog sensors and TrueAlert addressable appliances.

## Master Controller Bay module details

### Master Controller and Motherboard

- Master Controller mounts in Slot 2 of a two slot motherboard and provides one Class B or Class A, RUI+ communications channel configurable for isolated or un-isolated operation.
- Slot 1 of the motherboard is primarily for an optional network interface card, or secondarily for the 4100-6038 dual RS-232 board.
- RUI+ and RUI communications controls up to 31 remote devices for each master controller at up to 2500 ft (762 m) for single run, or 10,000 ft (3048 m) total if wiring is Class B and T-tapped. If more distance is required, up to four total RUI channels are supported. Add up to three 4100-1291 RUI Expansion Modules (4100-1291 provides unisolated RUI communications).
- Compatible RUI+ and RUI remote equipment includes: MINIPLEX transponders, 4603-9101 LCD Annunciators, 4602-9101 Status Command Units (SCU), 4602-9102 Remote Command Units (RCU), 4602 Series LED Annunciator Panels, 4100 Series 24 I/O and LED/Switch modules, (4602 series annunciators require un-isolated communications).
- Up to four RUI channels (combination of built-in RUI+ and optional RUI modules) are supported for each master controller.
- Open slot space on the left of the CPU motherboard is available for either another dual slot motherboard, or for one or two block modules, see Figure 18.

### ES-PS Master Controller power supply

- Rating is up to 9.5 A total without a fan or up to 12.7 A total with a fan using Special Application appliances, or up to 5 A total with Regulated 24 DC appliance loads.
- Outputs are power-limited, except for battery charger and city circuits.
- Provides system power, battery charging, auxiliary power, auxiliary relay, earth detection, electrically isolated IDNet 2 communications channel for 250 points (4100-3117), three 3 A conventional NACs (4100-5450) or three 3 A IDNAC addressable SLCs (4100-5451), two block spaces for compatible optional modules and provisions for either an optional City Connect Module or an optional Alarm Relay Module (City Connect or Alarm Relay module requires one available block space).
- **IDNet 2 SLC Output** (4100-3109 and 4100-3117) provides an electrically isolated Class B or Class A communications channel with dual short circuit isolating loops for up to 250 addressable devices, as described in Addressable Device Control (requires one block space from ES-PS power supply or Master Controller bay).
- **Conventional NAC Module** (4100-5450) provides three outputs individually selectable as a Conventional NAC (Class B or Class A) or an Auxiliary Power output. When mounted on the ES-PS power supply, each NAC is rated at 3 A for Special Application appliances (9 A max for each card) or 2 A for Regulated 24 DC loads (4 A max for each card). NAC operation supports synchronized strobe or SmartSync horn/strobe operation over two wires. Auxiliary power outputs are rated for 3 A continuous duty. The total auxiliary power output for each power supply is limited to 5 A (requires one block space).
- **IDNAC Addressable Notification SLC Module** (4100-5451) provides three 3 A IDNAC addressable notification SLCs compatible with both TrueAlert ES and TrueAlert addressable notification appliances and remote 4009 IDNAC Repeaters used to extend power and wiring distances (requires two block spaces).
- **Dual Class A IDNAC Isolator (DAI) Module** (4100-6103) creates two Class A outputs from one IDNAC SLC Class B input. Up to two



can be connected to one IDNAC SLC, with up to 6 total for each ES-PS power supply. The total Class A output loop current is limited to the 3 A rating of the IDNAC SLC and requires one block space.

- **Battery Charger** is dual rate, temperature compensated, and charges up to 50 Ah sealed lead-acid batteries mounted in the battery compartment, or 33 Ah for single bay cabinets. Also is UL and ULC listed for charging up to 110 Ah batteries mounted in an external cabinet. Refer to data sheet *S2081-0012* for details.
- **Battery and Charger Monitoring** includes battery charger status and low or depleted battery conditions. Status information provided to the master controller includes analog values for: battery voltage, charger voltage and current, actual system voltage and current, individual NAC currents, and individual IDNAC SLC currents.
- **Low Battery Cutout** is selectable for each ES-PS power supply.
- **2 A Programmable Output** is selectable for conventional SNAC or Auxiliary power operation.
  - SNAC operation supports conventional non-synchronous NAC operation to provide supervised reverse polarity for sounder base power, Suppression Release Peripheral (SRP) power, or other coded NAC operation requirements.
  - Auxiliary (AUX) power operation can be used for sounder base power, four-wire detector power, or door holder. Relay is selectable as N.O. or N.C and rated for 2 A at 32 VDC and 30 VAC (resistive). Supervised AUX operation does not require an end-of-line relay to provide Power-Limited operation.
- **Auxiliary Relay** is selectable as N.O. or N.C., rated 2 A at 32 VDC or 30 VAC (resistive), and is programmable as a trouble relay, either normally energized or normally de-energized, or as an auxiliary control.
- **Optional City Connect Module** (4100-6031, with disconnect switches, or 4100-6032, without disconnect switches) can be selected for conventional dual circuit city connections and requires one block space.
- **Optional Alarm Relay Module** (4100-6033) provides three Form C relays that are used for Alarm, Trouble, and Supervisory, rated 2 A resistive at 32 VDC and requires one block space.

## IDNet SLC for Addressable Device Communications

### Overview

The 4100ES provides standard addressable device communications for IDNet compatible devices and accepts optional modules for communications with MAPNET II compatible devices. Using a two wire communications circuit, you can interface individual devices such as manual fire alarm stations, TrueAlarm sensors, conventional IDC zones, and sprinkler waterflow switches to the addressable controller to communicate their identity and status.

Use the addressability feature to display the location and condition of the connected device on the operator interface LCD and remote system annunciators. Additionally, control circuits such as fans or dampers may be individually controlled and monitored with addressable devices.

### Addressable operation

Each addressable device on the communication channel is continuously interrogated for status condition such as: normal, off-normal, alarm, supervisory, or trouble. Both Class B and Class A operations are available. Sophisticated poll and response communication techniques ensure supervision integrity and allow for **T-tapping** of the circuit for Class B operation. Devices with LEDs pulse the LED to indicate receipt of a communications poll and can be turned on steady from the panel.

### IDNet channel capacity

The CPU bay ES-PS provides an IDNet 2 signaling line circuit (SLC) that supports up to 250 addressable monitor and control points intermixed on the same pair of wires. IDNet 2 and IDNet 2+2 Module SLCs are isolated from other system reference voltages to reduce common mode

noise interaction with adjacent system wiring. Additional 250 address IDNet 2 or IDNet 2+2 Modules are available, see Table 21.

**Table 1: IDNet, MAPNET II, IDNet 2, and IDNet 2+2 SLC wiring common specifications**

| Specification  | Description  |
|--|--|
| Maximum Distance from Control Panel for each Device Load | 1 to 125<br>126 to 250   |
|  | 4000 ft (1219 m), 50 ohms<br>2500 ft (762 m), 35 ohms                      |
| Connections  | Terminals for 18 to 12 AWG (0.82 mm <sup>2</sup> to 3.31 mm <sup>2</sup> ) |

**Table 2: IDNet and MAPNET II Specifications**

| Specification  | Description  |
|--|--|
| Wire Type  | New Installation<br>Retrofit Only                            |
|  | Shielded twisted pair (STP)<br>Unshielded twisted pair (UTP) |
| Total wire length allowed with T Taps for Class B Wiring | Up to 10,000 ft (3 km), 0.58 μF                              |

**Note:** For retrofit installations consult with your local Simplex product supplier, restrictions may apply.

**Table 3: IDNet 2 and IDNet 2+2 Wiring Specifications**

| Specification  | Description  |
|--|--|
| Wire Type  | New Installation<br>Retrofit Only  |
|  | Unshielded twisted pair (UTP)<br>Shielded or unshielded, twisted or untwisted wire |
| Total wire length allowed with T Taps for Class B Wiring   | Up to 12,500 ft (3.8 km), 0.60 μF  |
| Maximum Capacitance Between IDNet 2 Channels   | 1 μF   |
| IDNet 2 and IDNet 2+2 Module Compatibility: IDNet communicating devices and TrueAlarm sensors including QuickConnect and QuickConnect2 sensors |  |

**Note:** For retrofit installations consult with your local Simplex product supplier, restrictions may apply.

## TrueAlarm system operation

Addressable device communications include operation of TrueAlarm smoke and temperature sensors. Smoke sensors transmit an output value based on their smoke chamber condition and the CPU maintains a current value, peak value, and an average value for each sensor. Status is determined by comparing the current sensor value to its average value. Tracking this average value as a continuously shifting reference point filters out environmental factors that cause shifts in sensitivity.

**Programmable sensitivity** of each sensor can be selected at the control panel for different levels of smoke obscuration shown directly in percent, or for specific heat detection levels. To evaluate whether the sensitivity has to be revised, the peak value is stored in memory and can be easily read and compared to the alarm threshold directly in percent.

**CO sensor bases** combine an electrolytic CO sensing module with a TrueAlarm analog sensor to provide a single multiple sensing assembly using one system address. The CO sensor can be enabled or disabled, used in LED or Switch modes and custom control, and can be made public for communication across a fire alarm Network. Refer to data sheet *S4098-0052* for details.

**TrueAlarm heat sensors** can be selected for fixed temperature detection, with or without rate-of-rise detection. Utility temperature sensing is also available, to provide freeze warnings or alert to HVAC system problems. Readings can selected as either Fahrenheit or Celsius.

### TrueSense early fire detection

Multi-sensor 4098-9754 provides photoelectric and heat sensor data using a single 4100ES IDNet address. The panel evaluates smoke

activity, heat activity, and their combination, to provide TrueSense early detection. For more details on this operation, refer to data sheet S4098-0024 .

## Diagnostics and default device type

### Sensor status

TrueAlarm operation allows the control panel to automatically indicate when a sensor is almost dirty, dirty, and excessively dirty. The NFPA 72 requirement for a test of the sensitivity range of the sensors is fulfilled by the ability of TrueAlarm operation to maintain the sensitivity level of each sensor. CO Sensors track their 10 year active life status providing indicators to assist with service planning. Indicators occur at: 1 year, 6 months, and when end of life is reached.

### Modular TrueAlarm sensors

TrueAlarm sensors use the same base and different sensor types (smoke or heat sensor) and can be easily interchanged to meet specific location requirements. You can substitute the intentional sensor during building construction when conditions are temporarily dusty. Instead of covering smoke sensors (causing them to be disabled), heat sensors can be installed without reprogramming the control panel. The control panel can indicate an incorrect sensor type, but the heat sensor can operate at a default sensitivity to provide heat detection for building protection at that location.

## IDNAC SLC for addressable notification appliance communications

IDNAC addressable notification appliance communications include operation of the following appliances:

- TrueAlert and TrueAlert ES Visible only (V/O, strobe)
- Audible only (A/O, horn)
- Audible/Visible (A/V, horn/strobe)
- Strobes of Speaker/Visible (S/V)

**Note:** S/V appliances require separate speaker wiring.

Operators can use the IDNAC SLC to control each horn and strobe individually through a single two-wire circuit. The IDNAC SLC confirms the wiring connections to the electronic circuit of each notification appliance, and then confirms communication between the fire alarm control unit and each appliance. Addressable communications increases supervision integrity versus conventional notification systems by providing supervision beyond the circuit wiring to each individual appliance and by constantly verifying the ability of each appliance to communicate with the control panel.

### Individual appliance status and settings

The fire alarm control panel monitors and records each addressable notification appliance status, type of appliance, and its configured appliance settings. A fault in any individual appliance automatically reports a trouble condition to the control panel.

Figure 5: TrueAlert ES addressable appliance reference



### Virtual NACs provide control convenience

For control convenience, operators can group IDNAC notification appliances into *Virtual NACS* (VNACs) for group control. You can make that grouping across SLCs, not defined by their wiring connection.

### Panel control convenience

Applicable operation settings for each appliance can be programmed *without having to replace appliances or remove them from the wall or ceiling*. An appliance's VNAC notification zone can be easily changed through programming without having to add additional circuits, conduit, and wiring. Audible and visible appliances for non-Fire Emergency Communications notification can be programmed to operate separately *on the same pair of wires as the fire alarm notification appliances*. The result is lower installation, retrofit, and overall life-cycle cost of ownership compared with traditional conventional notification systems.

### Installation, retrofit, and life-cycle cost benefits

With each addressable appliance capable of being controlled separately on the same two-wire IDNAC SLC, installation time and expense for both retrofit and new construction can be significantly reduced. When Class B wiring is used, wiring can be **T-tapped** allowing more savings in distance, wire, conduit (size and utilization), and overall installation efficiency.

### Location information, diagnostics and troubleshooting

Each addressable notification appliance has its own 40 character custom label to identify the location of the appliance and to aid in troubleshooting fault conditions. In conventional notification systems, conventional appliances are not capable of communicating with the control panel. Fault reporting on a conventional system is limited to the circuit wiring and the entire area (zone) covered by appliances on the notification appliance circuit (NAC) making it much more difficult and costly to locate and correct the source of a problem. Using the TrueAlert *magnet test* allows each appliance to individually identify its candela setting and address and to briefly operate if desired, and using the **TrueAlert ES appliance Self-Test feature provides detailed performance verification for each appliance** .

## TrueAlert ES appliance Self-Test operation

### Onboard test sensors

For efficient and unobtrusive Self-Testing TrueAlert ES appliances are equipped with onboard sensors to detect strobe or horn output. When **Automatic Self-Test** is initiated from the control panel, each appliance in the selected VNAC group briefly operates and then reports its Self-Test status to the control panel, all in several seconds. If required you can select Silent Self-Test to test only visible appliance. The control panel is in a trouble condition during testing and in the event of an alarm, Self-Test is automatically terminated. **Additionally, Automatic Self-Test can be scheduled** to occur at a convenient time on a regular basis.

**Note:** Requires version 2.03.01 or higher software.

### Automatic Self-Test

Automatic Self-Test results are communicated to the control panel with a time and date stamp and are stored in memory. Results are viewable at the front panel display and printed reports can be generated from the panel service port.

### Individual Self-Test

Individual Self-Test is selected from the control panel when individual appliances need to be observed to operate. Each appliance in the selected VNAC group turns on its LED until individually activated by applying a magnet. After performing the individual test, the appliance LED turns off to indicate completion. Results are recorded the same as during the automatic test.

**TrueAlert ES appliance Self-Test last test results report example**

Figure 6: TrueAlertES Self-Test report

| Service Port                                    |                                      |                |         | Page 1    |  |
|---|--------------------------------------|----------------|---------|-----------|--|
| REPORT 10 TrueAlertES Self-Test Report          |                                      | 12:34:56pm WED |         | 03-DEC-14 |  |
| Point ID  | Custom Label                         | Date           | Visual  | Audible   |  |
| T1-1-1  | VO FIRST FLOOR (up to 40 characters) | 03-DEC-14      | NO OUT  | N/A       |  |
| T1-2-5  | AV FIRST FLOOR EAST WING             | 03-DEC-14      | NO OUT  | NORMAL    |  |
| T7-3-55   | AO SECOND FLOOR EAST WING            | 03-DEC-14      | N/A     | NO OUT    |  |
| T8-2-45   | AV SECOND FLOOR ROOM 29              | 03-DEC-14      | NOT TST | N/A       |  |
| T8-2-60   | AV SECOND FLOOR ROOM 22              | 03-DEC-14      | NORMAL  | NORMAL    |  |
| T1-2-4  | AO FIRST FLOOR ROOM 17               | 03-DEC-14      | N/A     | UNSUPP    |  |
| TRUEALERT_ES SELF-TEST REPORT COMPLETED         |                                      |                |         |           |  |
| Press RETURN for next Screen OR CTRL-X to abort |                                      |                |         |           |  |

**Results Description**

- **NORMAL** = Works correctly
- **NO OUT** = No Output, no light or sound was detected
- **NOT TST** = No result. Either the appliance did not return a result before the test ended or the test was conducted as silent (strokes only) and audible appliance was not activated
- **N/A** = Not applicable (no strobe, on audible only)
- **UNSUPP** = Appliance not compatible with Self-Test (TrueAlert addressable appliance not TrueAlert ES addressable appliance)

**Note:** Additional TrueAlert ES Self-Test information is detailed in ES Operating Instructions 579-197 shipped with the panel.

**TrueAlert ES appliance Self-Test all test results report example**

Figure 7: TrueAlertES Self-Test report

| Service Port                                    |                               |                |         | Page 1    |  |
|---|-------------------------------|----------------|---------|-----------|--|
| REPORT 10 TrueAlertES Self-Test Report          |                               | 12:34:56pm WED |         | 03-DEC-14 |  |
| Point ID  | Custom Label                  | Date           | Visual  | Audible   |  |
| T1-1-1  | VO FIRST FLOOR                | 03-DEC-14      | NO OUT  | N/A       |  |
| T1-2-5  | AV FIRST FLOOR EAST WING      | 03-DEC-14      | NO OUT  | NORMAL    |  |
| T1-2-6  | AV FIRST FLOOR NORTH ENTRANCE | 30-OCT-14      | NO OUT  | NORMAL    |  |
| T7-3-55   | AO SECOND FLOOR EAST WING     | 03-DEC-14      | N/A     | NO OUT    |  |
| T8-2-45   | AV SECOND FLOOR ROOM 29       | 03-DEC-14      | NOT TST | N/A       |  |
| T1-1-11   | AV FIRST FLOOR SOUTH ENTRANCE | 30-OCT-14      | NORMAL  | NORMAL    |  |
| T8-2-60   | AV SECOND FLOOR ROOM 22       | 03-DEC-14      | NORMAL  | NORMAL    |  |
| T1-2-4  | AO FIRST FLOOR ROOM 17        | 03-DEC-14      | N/A     | UNSUPP    |  |
| T1-2-7  | AO FIRST FLOOR ROOM 12        | 30-OCT-14      | N/A     | UNSUPP    |  |
| T8-3-43   | AV SECOND FLOOR ROOM 25       | 30-OCT-14      | UNSUPP  | UNSUPP    |  |
| TRUEALERT_ES SELF-TEST REPORT COMPLETED         |                               |                |         |           |  |
| Press RETURN for next Screen OR CTRL-X to abort |                               |                |         |           |  |

### TrueAlert ES appliance Self-Test individual appliance report example

Figure 8: Appliance report

|                              |                        |
|------------------------------|------------------------|
| CUSTOM LABEL                 |                        |
| 4-1-2                        | AV                     |
| POINT ADDRESS: 4-1-2         | Type: AV               |
| CARD: 4 CHANNEL: 1 DEVICE: 2 |                        |
| EXTENDED POWER SUPPLY        |                        |
| UNIT NUMBER: 2               | RUI NUMBER: LOCAL      |
| PRIMARY STATUS               | NORMAL                 |
| AUDIBLE GROUP CONFIG:        | 0 0 0                  |
| VISUAL GROUP CONFIG:         | 0 0 0                  |
| STYLE:                       | INDOOR                 |
| OPERATION:                   | GENERAL EVAC           |
| CANDELA RATING               | 15 CD                  |
| COLOR LENS                   | YES                    |
| TONE TYPE                    | BROADBAND              |
| CODING TYPE                  | TEMPORAL               |
| VOLUME                       | HIGH                   |
| LAST TEST TIME:              | MON 02-JUN-14 01:00 AM |
| LAST VISUAL TEST:            | NORMAL                 |
| LAST AUDIBLE TEST:           | NORMAL                 |
| LAST TEST VOLUME:            | NORMAL                 |
| DEVICE TEST TROUBLE:         | NORMAL                 |

### IDNAC SLC hardware reference

#### ES-PS power supplies

ES-PS power supplies configured with an IDNAC card provide three, 3 A IDNAC SLCs for control and power to TrueAlert ES and TrueAlert addressable notification appliances. Both power supplies incorporate an efficient switching design that provides a regulated output of 29 VDC, even during battery operation. With 29 VDC minimum output at the panel, addressable notification SLCs can support wiring distances two to three times farther than available with conventional notification, or support more appliances for each SLC, or work with smaller gauge wiring, or combinations of these benefits, all resulting in installation and maintenance savings with high assurance that appliances that operate during normal system testing can operate during worst case alarm conditions.

### IDNAC SLC appliance wiring reference

#### IDNAC SLC capacity

Up to 127 addresses and up to 139 unit loads. Appliances are typically one unit load. Devices such as Isolators may require more than one load. For specific information refer to individual device data sheet.

Table 4: IDNAC SLC appliance wiring reference

| Specification  | Rating   |
|--|--|
| Required wire type   | Unshielded twisted pair (UTP)  |
| Maximum wire length allowed with T-Taps for Class B wiring, for each SLC | 10,000 ft (3048 m)   |
| Maximum wire length for each SLC to any appliance                        | 4000 ft (1219 m)   |
| Appliance supervisory current  | 1 unit load = 0.8 mA for each appliance                                    |
| Wiring connections   | Terminals for 18 to 12 AWG (0.82 mm <sup>2</sup> to 3.31 mm <sup>2</sup> ) |
| Installation Instructions (see for more information)                     | 579-1015   |

### 8-Point Zone/Relay Module details

• **Select as IDC or Relay and configure:**

- Up to eight Class B IDCs or up to four Class A IDCs
- Up to eight Relay outputs rated 2 A resistive at 30 VDC (N.O. or N.C.)
- Combinations of IDCs and Relays.

**Note:** Each zone is separately configurable as an IDC or Relay output.

- **IDC Support:** each IDC supports up to 30, two-wire devices. Zone relay modules can be powered directly from the control unit power supply or through the optional 25 VDC regulator module where required for two-wire detector compatibility. Refer to 2-Wire Detector Compatibility document 579-832 for additional details.
- **IDC EOL resistor values are selectable as:** 3.3 kΩ, 2 kΩ, 2.2 kΩ, 3.4 kΩ, 3.9 kΩ, 4.7 kΩ, 5.1 kΩ, 5.6 kΩ, 6.34/6.8 kΩ, and 3.6 kΩ + 1.1 kΩ. See instructions for more details.

**Color ES Touch Screen Display**

The Color ES Touch Screen Display interface offers intuitive operation similar to a tablet or smart phone. With a larger area format versus an individual text line display, more information is available at a glance, and minimal key presses are needed to access detailed information.

Figure 9: ES Touch Screen Display operator interface

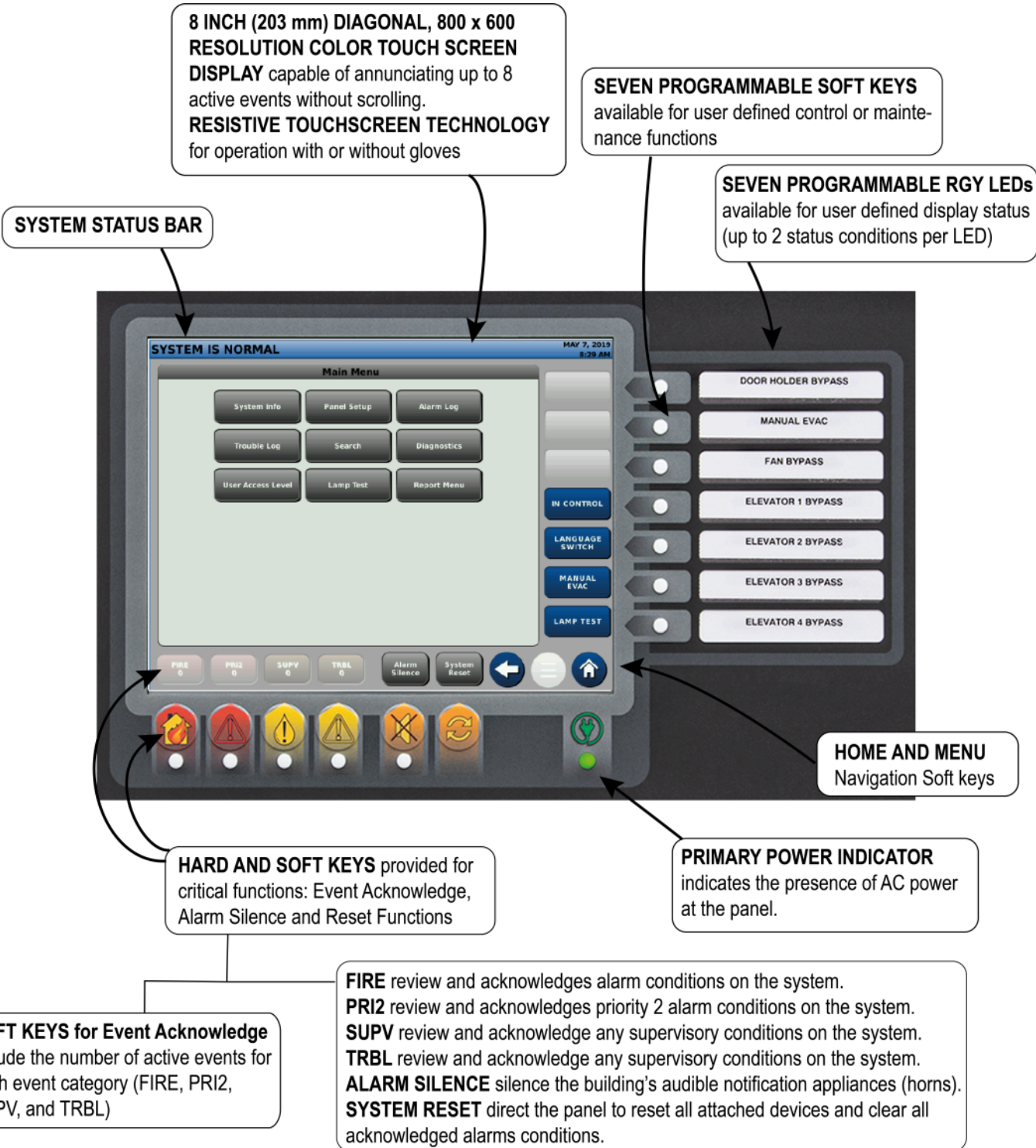

**Features**

**ES Touch Screen Displays provide customized operating experience**

- Event activity display choices include: First 8 Events or First 7 Events with emphasis on Most Recent, or First 6 Events with emphasis on First and Most Recent (individually selectable for each event type).
- System reports are easily viewable. Logs can be read with minimal scrolling.

- Up to two languages are available for a system, easily selected by programmable key press.
- Information sent to Remote ES Touch Screen Displays can be vectored by point or zone.
- Both Hard and Soft keys available for critical functions: Event Acknowledge, Alarm Silence, and Reset Functions.
- Resistive touchscreen technology allows operation with or without gloves.
- Seven programmable RGY LEDs available for user-defined display status (up to 2 status conditions for a LED).
- Seven programmable Soft keys available for user-defined control or maintenance functions.
- PRI2 Soft key label can be changed to CO to annunciate Carbon Monoxide detection status.
- ES Touch Screen Display can be programmed to report individual points or groups of points as a single zone.
- Supports ability to display a custom watermark background file of a company logo or other display content.
- Seismically compliant under the State of California Statewide Office of Housing and Development (OSHDP) Special Seismic Certification (SSC) program guidelines. Refer to *Simplex Seismic Application Guide* 579-1213 and *Battery Brackets for Seismic Activity Applications* S2081-0019 for details.

### Display properties

- 8 inch (203 mm) diagonal, 800 x 600 resolution color touch screen display capable of annunciating up to 8 active events without scrolling.
- Bright white LED backlighting provides efficient and long lasting illumination. Backlight is dim in quiescent state, automatically switches to full power on touch or on event activity in system.

### Description

ES Touch Screen Displays for 4100ES fire alarm systems provide a large display with extended information content, dual language support including UTF-8 character languages, and an intuitive control key interface with the following:

- Up to 10 ES Touch Screen Displays are supported for each 4100ES control panel. Able to allow one ES Touch Screen Display to take-control and to designate access levels for interfaces not in-control. Programmable LEDs can be assigned to in-control status indications.
- Menu-driven format conveniently prompts operators for the next action required.
- Direct point callup displays individual points alphabetically and then homes in on the logical choice as more point information is entered.
- Event categories are color coded for quick visual representation:
  - Red for Alarm and Priority 2 Events
  - Yellow for Supervisory and Trouble events.
- Date formats are either MM/DD/YY or DD/MM/YY.
- Time formats are either 24 hour or 12 hour with AM/PM.
- System Normal screen supports a color background (watermark) for company name, company logo, or other display content.

Example display screens

Table 5: Example display screens

Figure 10: First and most recent alarm display

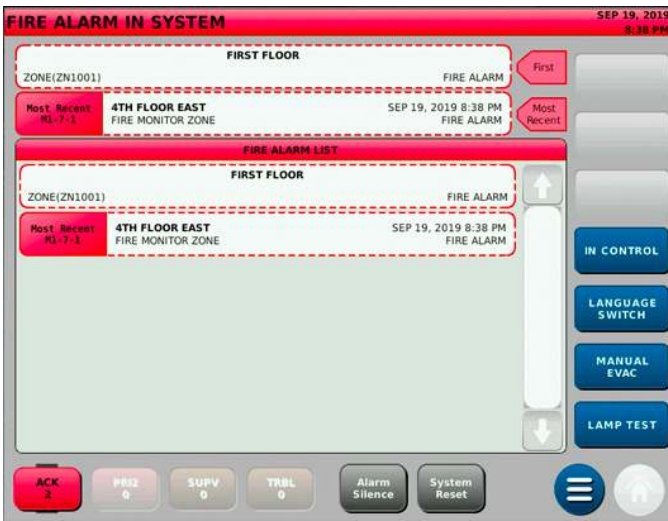

Figure 12: First eight active trouble events list



Figure 14: Alarm history log



Figure 11: Main menu



Figure 13: Direct point callup



Figure 15: Detailed point status screen for TrueAlert ES appliance

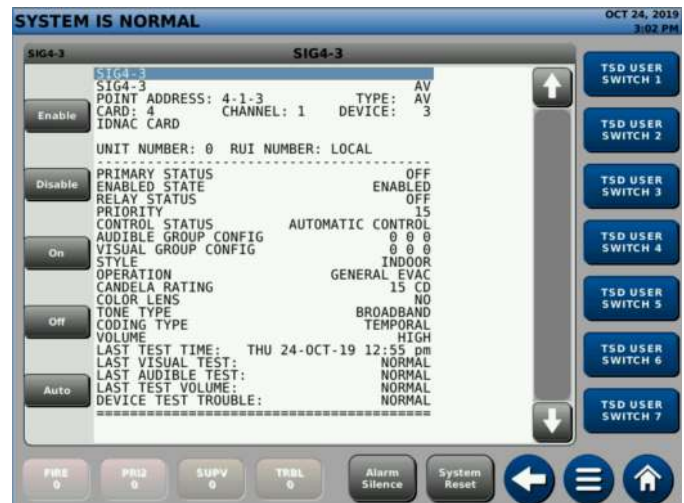

---

**Specifications****Table 6: General ES Touch Screen Display specifications**

| <b>Specification</b>                       | <b>Rating</b>   |
|--|---|
| Resolution                                 | 800 x 600 Pixels (RGB)  |
| Size / Type                                | 8 in. (203 mm) Diagonal / Color Touch Screen                            |
| Touch Screen technology                    | Resistive   |
| Event display                              | Up to 8 events without scrolling  |
| Normal Screen custom watermark file format | 680 x 484 Pixels: BMP, JPG, TIFF, GIF or PNG file format                |
| Environmental                              | Operating temperature: 32°F to 120°F (0°C to 49°C)                      |
|  | Operating humidity: Up to 93% RH, non-condensing at 90°F (32°C) maximum |



**Operator interface with monochrome 2 x 40 LCD**

With the locking door closed, the glass window allows viewing of the display, status LEDs, and available operator switches. Features include a two-line by 40-character, wide viewing angle (super-twist) LCD with status LEDs and switches as shown in Figure 16.

LED indicators describe the general category of activity being displayed with the LCD providing more detail. For the authorized user, unlocking the door provides access to the control switches and allows further inquiry by scrolling the display for additional detail.

- Convenient and extensive operator information is provided using a logical, menu-driven display
- Multiple automatic and manual diagnostics for maintenance reduction
- Alarm and Trouble History Logs (up to 1000 entries for each, 2000 total events) are available for viewing from the LCD, or capable of being printed to a connected printer, or downloaded to a service computer
- Convenient PC programmer label editing
- Password access control

Figure 16: Operator interface

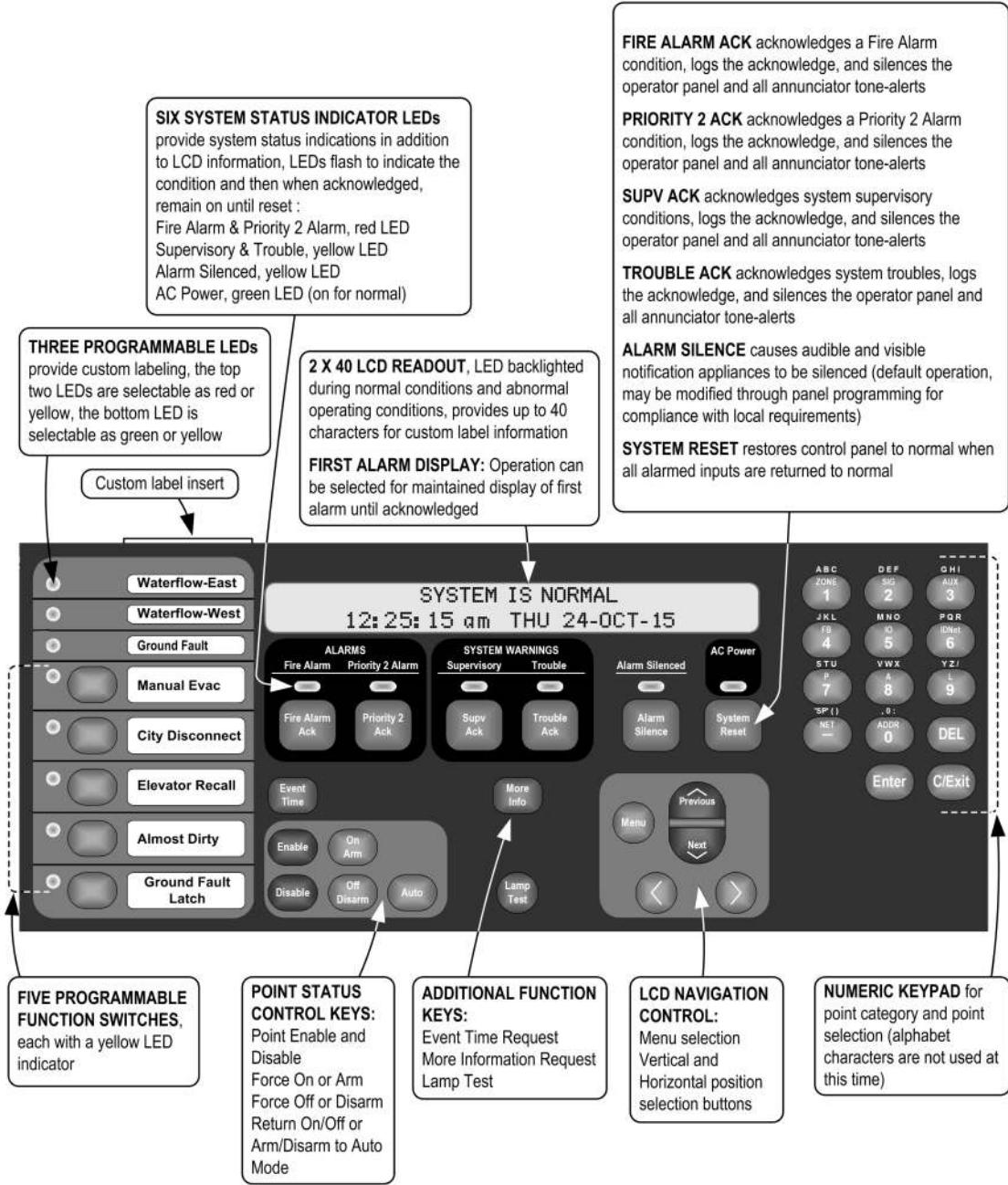

**Expansion Bay module loading reference**

Figure 17: Expansion Bay chassis

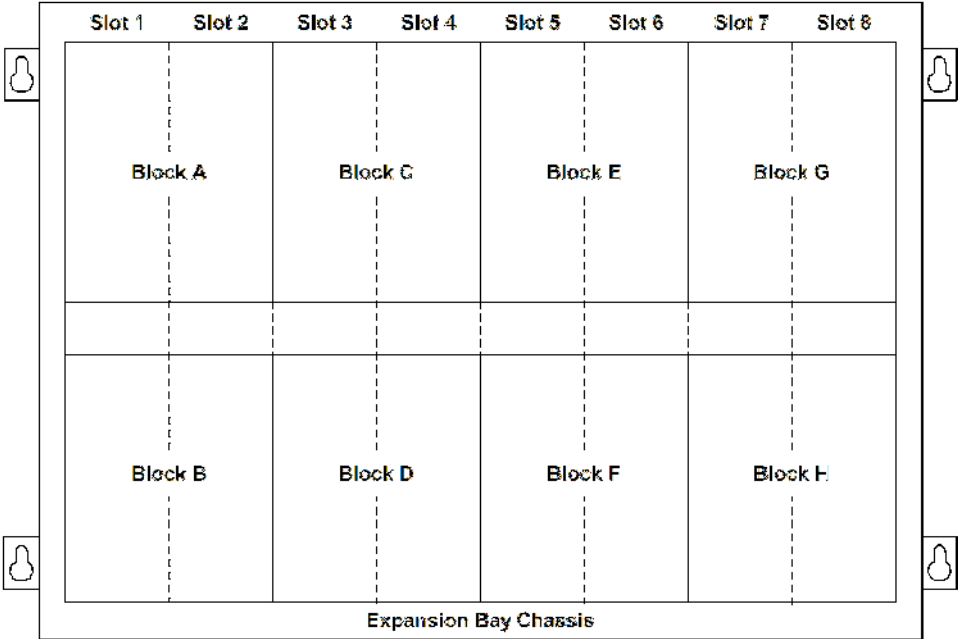

**Size definitions:** Block = 4 in. W x 5 in. H (102 mm x 127 mm) card area  
 Slot = 2 in. W x 8 in. H (51 mm x 203 mm) motherboard with daughter card

**Table 7: Expansion Bay loading reference**

| Description                |                   | Mounting                           |
|----------------------------|-------------------|------------------------------------|
| IDNet 2, IDNet 2+2 Modules |                   | 1 Block                            |
| Four 2 A Relays            | NON Power-limited | 1 Block                            |
| Four 10 A Relays           |                   | 4 in., 2 Slots                     |
| Eight 3 A Relays           |                   | 1 Block                            |
| VESDA Interface            |                   | 2 in., 1 Slot                      |
| Class B IDC                |                   | 2 in., 1 Slot                      |
| Class A IDC                |                   | 2 in., 1 Slot                      |
| MAPNET II Module           |                   | 4 in., 2 Slots                     |
| MAPNET II/IDNet Isolator   |                   | 2 in., 1 Slot                      |
| NAC Card                   |                   | 1 Block                            |
| IDNAC Card                 |                   | 2 Blocks (on ES Power Supply only) |
| ES-PS                      |                   | Blocks G and H ONLY                |
| ES-PS Configured as backup |                   | Blocks E and F ONLY                |
| ES-XPS                     |                   | 2 Blocks                           |

**Mounting and Master Controller Bay module reference**

Figure 18: Mounting and CPU Bay module reference

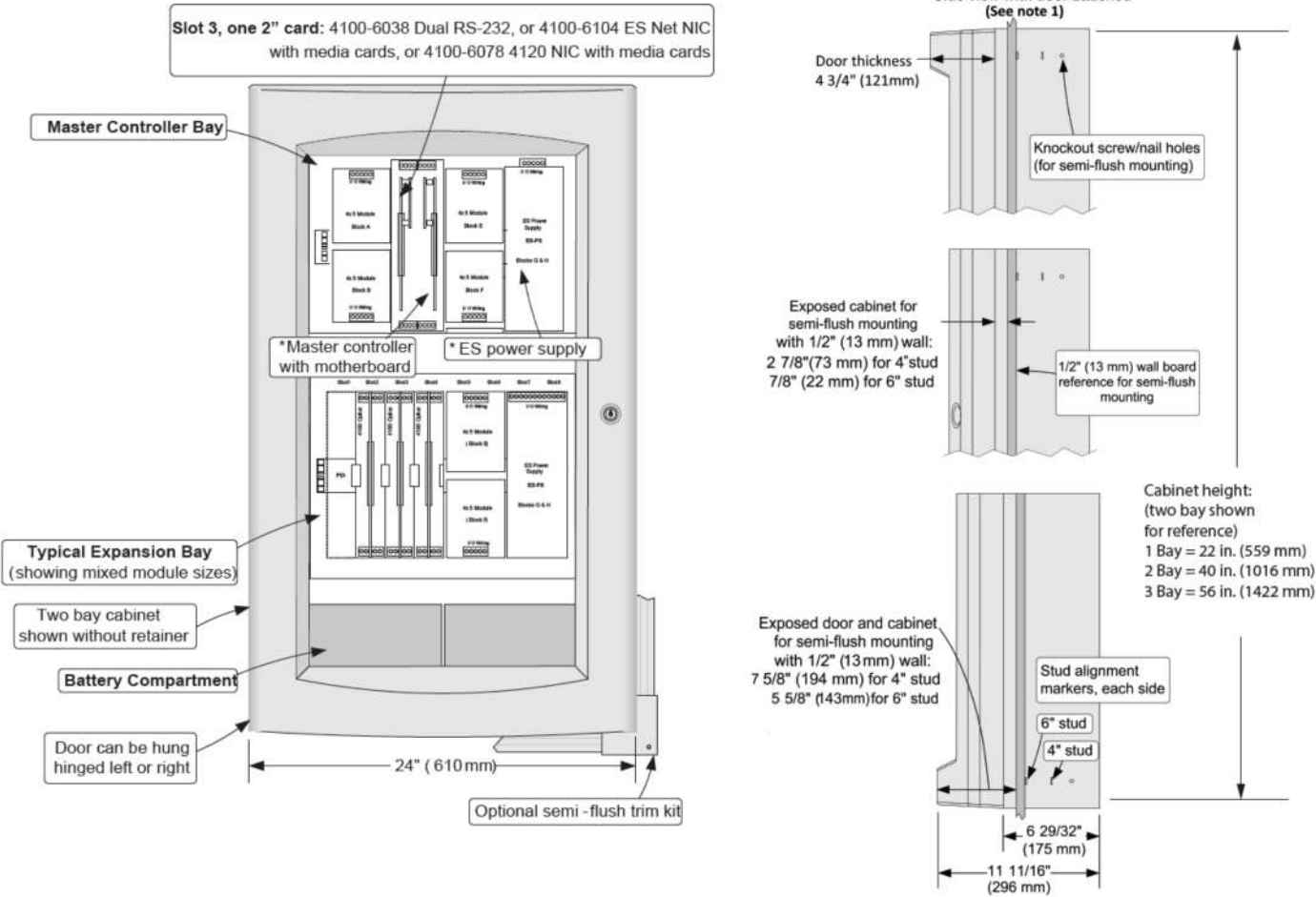

**Note:**

1. Side View dimensions are shown with minimal cabinet and door protrusion from the exterior wall. For 6 in. stud construction with minimum protrusion shown, the door opens 90 degrees. To allow the door to open 180 degrees, the exposed cabinet dimension from the exterior wall must be a minimum of 3 in. (76 mm) for both 4 in. and 6 in. stud construction.
2. Asterisks (\*) in Figure 18 indicate supplied modules.
3. A system ground must be provided for earth detection and transient protection devices. This connection can be made to an approved, dedicated earth connection for each NFPA 70, article 250, and NFPA 780.

## General specifications

**Table 8: ES Power Supply specifications (ES-PS and ES-XPS)**

| Specifications   | Rating   |
|--|--|
| <b>AC input power</b>  | 120 to 240 VAC   |
| 120 VAC  | 3.72 A   |
| 220 to 240 VAC   | 1.82 A   |
| <b>Total DC output power capacity</b>  |  |
| Without fan  | 9.5 A  |
| With 4100-5131 fan and 4100-5451 IDNAC module(s)   | 9.7 A  |
| With 4100-5131 fan (without 4100-5451 IDNAC module)  | 12.7 A   |
| With Regulated 24V appliance loads (with or without 4100-5131 fan)                               | 5.0 A  |
| <b>Special application appliance loads:</b> supports full total DC output power capacity ratings | Simplex horns, strobes, and combination horn/strobes and speaker/strobes (contact your Simplex product representative for compatible appliances) |
| <b>Regulated 24V appliances:</b> reduces total DC output power capacity to 5.0 A                 | Power for other UL listed appliances. Use associated external synchronization modules where required.  |
| <b>Auxiliary power tap</b>   | 2 A maximum (taken from total output power capacity)   |
| <b>NACs programmed for auxiliary power</b>   | 3 A maximum for each NAC, 5 A maximum total (taken from total output power capacity)   |
| <b>Battery charger (ES-PS only)</b>  | Sealed lead-acid batteries   |
| Battery Ah capacity  | UL/ULC listed for battery charging of up to 110 Ah (batteries larger than 50 Ah require a remote battery cabinet)                                |
| Charger characteristics and performance  | Temperature compensated, dual rate, recharges depleted batteries in 48 hours   |
| <b>Environmental</b>   |  |
| Operating Temperature  | 32°F to 120°F (0°C to 49°C)  |
| Operating Humidity   | Up to 93% RH, non-condensing at 90°F (32°C) maximum  |
| <b>Option Card Mounting</b>  | 2 vertical blocks are available fore compatible modules. Refer to 579-1288 installation instructions for additional details.                     |

**Note:**

- Battery charger is only available on the ES-PS Power Supply.
- When an ES-PS is used to power Flex-35 or Flex-50 Amplifiers the ES-PS battery charger is not available.

## Master Controller Selection information

**Note for Table 9 and Table 10**

Supervisory and alarm currents are without IDNet devices. Add IDNet device currents separately.

**Table 9: 4100ES Master Controller Selection**

| Model     | Description   | Includes   | Listings     | Supv.                | Alarm                |
|-----------|---|--|--------------|----------------------|----------------------|
| 4100-9701 | ES-PS Master Controller with 2x40 Display - English         | Master Controller – English, 2x40 Display, CPU Card, IDNet 2 Card supports up to 250 addressable/analog points, ES Power Supply (120 V to 240 V 50/60 Hz, 24 V Aux. Relay, 24 V Aux. Power Tap/Simple NAC, 110 Ah Battery Charger) and external RUI+ (isolated or un-isolated) communications interface. | UL/ULC       | 277 mA<br>(See note) | 321 mA<br>(See note) |
| 4100-9702 | ES-PS Master Controller with 2x40 Display - Canadian French | Same as 4100-9701 except with Canadian French user interface.  | ULC          |                      |                      |
| 4100-9706 | ES-PS Master Controller with ES Touch Screen Display        | Same as 4100-9701 except with Color ES Touch Screen Display user interface. For dual language support, desired language is switch selectable.  | UL/ULC, CSFM | 362 mA<br>(See note) | 441 mA<br>(See note) |
| 4100-9709 | ES-PS Master Controller without Display - English           | Same as 4100-9701 except with no 2x40 Display or user interface.   | UL/ULC       | 277 mA<br>(See note) | 321 mA<br>(See note) |

**Note:**

- The Master Controller current draw specifications do not include IDNet, NAC, or IDNAC current draws. These must be added separately as required.
- International orders may substitute MX Loop Module (4100-3120) in place of IDNet 2 Module (4100-3117). Refer to data sheet S4100-0059 for more details. The 4100-3120 provides the same module and specifications as the 4100-6311 but is dedicated as a Master Controller feature selection.
- At the time of publication English and Canadian French languages are available for ES Touch Screen Display models. Contact your local Simplex product supplier for the latest status and availability for other languages.

**Table 10: 4100ES Master Controller upgrades for existing 4100 series Fire Alarm Control Panels**

| Model     | Panel Type   | Includes   |
|-----------|--|--|
| 4100-7150 | 1000 pt 4100 (4100+)                                       | New Master Controller CPU card, 4100ES door assembly with 2 x 40 LCD operator interface, and Ethernet connection   |
| 4100-7152 | 512 pt 4100  | Same as 4100-7150 plus a Universal Power Supply  |
| 4100-7158 | 4100U or 1000 pt 4100 (4100+) previously upgraded to 4100U | New Master Controller CPU card with Ethernet Connection Upgrade Kit (door assembly with user interface not included) for:<br>4100U with or without operator interface, or 4100+ and operator interface, or an existing 4100 (512 pt) or 4100+ (1000 pt) panel that was previously upgraded to a 4100U Master Controller and operator interface |
| 4100-7162 | 1000 pt 4100 (4100+)                                       | New Master Controller CPU card, 4100ES door assembly with Color ES Touch Screen Display user interface and Ethernet connection for 4100+ cabinet (requires 4100ES Version 6.01 or higher)  |
| 4100-7163 | 4100+ Cabinet upgraded with New Master Controller CPU card | 4100ES door assembly with Color ES Touch Screen Display user interface and Ethernet connection for 4100+ cabinet previously upgraded with New Master Controller CPU card (requires 4100ES Version 6.01 or higher)  |
| 4100-7164 | 2000 pt 4100 (4100U)                                       | New Master Controller CPU card, 4100ES door assembly with Color ES Touch Screen Display user interface and Ethernet connection for 4100U cabinet (requires 4100ES Version 6.01 or higher)  |

**Table 11: ES Touch Screen Display user interface upgrade kit**

| Model     | Panel type       | Description  |
|-----------|------------------|--|
| 4100-7165 | 4100ES or 4010ES | New ES Touch Screen Display user interface for upgrading an existing 4100ES 2x40 LCD or InfoAlarm user interface, or for upgrading an existing 4010ES InfoAlarm User Interface to a new ES Touch Screen Display user interface |

**Table 12: Master Controller accessories**

| Model     | Description   |
|-----------|---|
| 4100-2300 | Expansion Bay Assembly, order for each required expansion bay (not required for 4100-9121)  |
| 4100-2303 | Legacy Module Stabilizer Bracket, used when expansion bays have legacy slot style modules   |
| 4100-2301 | Expansion Bay upgrade kit for mounting 4100ES style (4 in. x 5 in. modules) in existing 4100 style panels<br><b>Note:</b> When using this kit to upgrade a 4100+ transponder, a 4100-0620 Transponder Interface Card (TIC) is also required for communications to the 4100ES module |

**Table 13: Master Controller upgrades for existing 4020 series Fire Alarm Control Panel**

| Model     | Description  |
|-----------|--|
| 4100-9833 | 4020 Master Controller upgrade to 4100ES. Includes New Master Controller with 2 x 40 LCD and operator interface assembly, 8 VDC Converter and RUI+ (isolated or un-isolated) Interface in a single bay cabinet with locking glass door and retainer. Mounts as an adjunct panel close-nipped to existing 4020 cabinet. Also includes 8 VDC box-to-box power and communications harness and solid filler panel for the existing 4020 Master Controller Bay. |

## Module Selection Information

### Current Calculation Notes

To determine total supervisory current, add currents of modules in panel to base system value and all external loads powered by panel power supplies.

To determine total alarm current, add currents of modules in panel to base system alarm current and add all panel NAC loads and all external loads powered from panel power supplies.

**Table 14: Communication Modules**

| Model     | Description  | Size     | Supv.  | Alarm  |
|-----------|--|----------|--------|--------|
| 4100-1291 | Un-isolated remote unit interface module (RUI), up to three maximum for each control panel   | 1 Slot   | 85 mA  | 85 mA  |
| 4100-6031 | <b>Select one</b> City Circuit, with disconnect switches   | 1 Block  | 20 mA  | 36 mA  |
| 4100-6032 | City Circuit, without disconnect switches  |          | 20 mA  | 36 mA  |
| 4100-6033 | Alarm Relay, three Form C relays, 2 A at 32 VDC  |          | 15 mA  | 37 mA  |
| 4100-6038 | Dual Port RS-232 with 2120 interface (slot module)   | 1 Slot   | 132 mA | 132 mA |
| 4100-6048 | VESDA Aspiration System Interface  | 1 Slot   | 132 mA | 132 mA |
| 4100-6080 | DACT, Point or Event Reporting. One shipped unless 4100-7908 is selected. Two max. for each system, includes two 2080-9047 cables, 14 ft (4.3 m) long, RJ45 plug and spade lugs. | Side Mt. | 30 mA  | 40 mA  |

**Table 15: Connected Services Gateway with IP communicator**

| Model     | Description   | Size     |
|-----------|---|----------|
| 4100-2504 | Connected Services Gateway with IP communicator, side mount     | 1 slot   |
| 4100-2506 | Connected Services Gateway with IP communicator, vertical mount | 2 blocks |

**Table 16: ES Power Supplies**

| Model     | Voltage                  | Description | Includes  | Provides Power to Bay | Size     | Supv. | Alarm |
|-----------|--------------------------|-------------|---|-----------------------|----------|-------|-------|
| 4100-5401 | 120 to 240 V<br>50/60 Hz | ES-PS       | 24 V Aux. Relay, 24 V Aux. Power 2 A Tap/ Simple NAC, 110 Ah Battery Charger, 2 PDI Blocks for compatible option cards. | Yes                   | 2 Blocks | 68 mA | 77 mA |
| 4100-5402 | 120 to 240 V<br>50/60 Hz | ES-XPS      | Same as ES-PS, except without battery charger   | No                    |          |       |       |

**Table 17: Power supply accessories**

| Model     | Description  | Size  | Current  |
|-----------|--|---|--|
| 4100-5152 | 12 VDC Power Option, 2 A maximum   | 1 Block   | 1.5 A maximum  |
| 4100-0156 | 8 VDC Converter, required for multiple Physical Bridge Modules, 3 A maximum  | 1 Block   | included with loads                                      |
| 4100-5130 | Voltage Regulator Module, 22.8 to 26.4 VDC (25 VDC nominal); isolated and resettable output; includes earth detection circuit and trouble relay for status monitoring.                     | 1 Block   | 3 A maximum with 2.5 A load, 4.9 A maximum with 4 A load |
| 4100-5131 | ES-PS Fan Module, allows more than one power supply to be installed in a single bay and may increase total DC output power capacity for each power supply. See Table 8 for specifications. | N/A   | 0 mA Supv. 200 mA Alarm                                  |
| 4100-0636 | Box Interconnection Harness Kit (non-audio); order one for each close-nippled cabinet  |   |  |
| 4100-0638 | 4100 Slot Module Additional 24 VDC Harness; needed when 4100 Slot module requirements exceed 2 A from ES-PS  |   |  |
| 4100-5403 | Harness for ES-PS Backup Power Supply  |   |  |
| 4100-0644 | 120 VAC PDM Harness  | One PDM harness is required for each power supply, select as required for appropriate input voltage |  |
| 4100-0645 | 220 VAC PDM Harness  |   |  |
| 4100-0646 | 230 VAC PDM Harness  |   |  |
| 4100-0647 | 240 VAC PDM Harness  |   |  |

**Table 18: Conventional and Addressable Notification Appliance Modules**

| Model     | Description                               | Outputs        | Size                               | Max Load - Special Application |                             | Max Load - Regulated 24 V   |                             | Current Draw |        |
|-----------|---|----------------|------------------------------------|--------------------------------|-----------------------------|-----------------------------|-----------------------------|--------------|--------|
|           |   |                |                                    | On ES-PS / ES-XPS              | In Bay                      | On ES-PS / ES-XPS           | In Bay                      | Supv.        | Alarm  |
| 4100-5450 | Conventional NAC Module                   | Three 3 A NACs | 1 Block                            | 3.0 A / NAC<br>9.0 A / Card    | 3.0 A / NAC<br>6.0 A / Card | 2.0 A / NAC<br>5.0 A / Card | 2.0 A / NAC<br>2.0 A / Card | 66 mA        | 66 mA  |
| 4100-5451 | IDNAC Addressable Notification SLC Module | Three 3 A SLCs | 2 Blocks (on ES Power Supply only) | 3.0 A / NAC<br>9.0 A / Card    | N/A                         | N/A                         |                             | 124 mA       | 230 mA |

**Note:**

- Special Application specifications apply to both Special Application and Steady Aux Power loads during alarm operation. Available power during non-alarm operation is 5.0 A maximum.
- The 4100-5450 and 4100-5451 can only be powered from a 4100-5401 and 4100-5402 power supply.

**Table 19: Dual Class A Isolator for IDNAC**

| Model     | Description   | Size    | Supv.  | Alarm   |
|-----------|---|---------|--------|---------|
| 4100-6103 | <b>Dual Class A IDNAC Isolator (DCAI):</b> <ul style="list-style-type: none"> <li>• Converts a single Class B IDNAC SLC input to two Class A SLC outputs</li> <li>• Provides short circuit isolation between each Class A output circuit</li> <li>• Connect up to two DCAI Modules for each IDNAC SLC input up to a maximum of 6 DCAI Modules for each IDNAC SLC</li> <li>• Each isolated output SLC used requires one IDNAC address</li> <li>• The total current remains controlled by the Class B input source SLC at 3 A maximum</li> <li>• Each isolated loop supports up to 30 device addresses</li> </ul> <p><b>Note:</b> You can install up to 30 additional device addresses between each 4905-9929 TrueAlert Addressable Isolator+ Module, not to exceed the maximum address and unit loading specifications for the IDNAC channel</p> | 1 Block | 8.3 mA | 18.5 mA |

**Table 20: 8-Point Zone/Relay Card**

| Model     | Description   | Size    | Supv. | Alarm  |
|-----------|---|---------|-------|--------|
| 4100-5013 | 8 point zone/relay 4 in. x 5 in. flat module. Supports eight Class B or four Class A IDCs. Mounts in any open block in a master controller or expansion bay. Alarm current shown is for eight Class B IDCs using 3.3K end-of-line-resistors with four in alarm and four in standby. Standby current shown is for all eight IDCs in standby. Refer to 579-1236 Zone/Relay Module Installation Instructions for additional information. | 1 Block | 83 mA | 295 mA |
| 4100-6305 | 25 V regulator harness for 8 point zone/relay module. One required for each 8 point zone/relay module to be powered by the 4100-5130 25 V regulator module. A maximum of five 8 point zone/relay modules may be powered from the 4100-5130 for each bay.  | N/A     | N/A   | N/A    |

**Note:** Modules in Table 20 requires 4100ES Version 3.06 or later.

**Table 21: IDNet Addressable Interface Modules**

| Model     | Description  | Devices | Standby | Alarm  |
|-----------|--|---------|---------|--------|
| 4100-3109 | IDNet 2 Module, 250 point capacity. Electrically isolated output with two short circuit isolating Class B or Class A output loops, 1 block. Standard on ES-PS with IDNet 2 Module. Alarm currents for 50 and above devices includes 20 device LEDs in alarm. | none    | 50 mA   | 60 mA  |
| 4100-3117 |  | 50      | 90 mA   | 150 mA |
| 125       |  | 150 mA  | 225 mA  |        |
| 250       |  | 250 mA  | 350 mA  |        |
| 4100-3110 | IDNet 2+2 Module, 250 point capacity. Electrically isolated output with four short circuit isolating Class B or Class A output loops, one block. Alarm currents for 50 and above devices includes 20 device LEDs in alarm.                                   | none    | 50 mA   | 60 mA  |
|           |  | 50      | 90 mA   | 150 mA |
|           |  | 125     | 150 mA  | 225 mA |
|           |  | 250     | 250 mA  | 350 mA |
| 4100-3111 | IDNet Short Circuit Isolating Loop Output Module. Mount up to two on a 4100-3109 or 4100-3117 module. This option is for aftermarket field installation only. Total initiating SLCs for each CPU, including VESDA Interface is 30.                           |         |         |        |

**Note:** Each IDNet 2 and IDNet 2+2 Short Circuit Isolating Loop Output can be individually controlled for system diagnostics and can be assigned a public point for Fire Alarm Network.

**Table 22: Current draw for each IDNet device**

| Condition           | Current |
|---------------------|---------|
| Standby             | 0.8 mA  |
| Alarm, with LED off | 1.0 mA  |
| Alarm, with LED on  | 3.0 mA  |

**Note:** A maximum of 20 devices with LED on is supported for each channel. Additional device LEDs do not turn on.

**Table 23: MAPNET Addressable Interface Modules**

| Model     | Description  | Supv.                      | Alarm  |
|-----------|--|----------------------------|--------|
| 4100-3102 | MAPNET II Module, 127 point capacity, add devices separately. Module size = 2 Slots. Loading for each MAPNET II device = 1.7 mA.   | Module without devices     | 255 mA |
|           |  | Fully loaded module, total | 471 mA |
| 4100-3103 | Isolator Module for MAPNET II communications; converts a single connected SLC into four isolated outputs selectable as Class A or Class B. Up to two Isolator Modules can be connected to one SLC. Module size = 1 Slot.<br><b>Note:</b> Compatible with MAPNET II Remote Isolators only | 50 mA                      | 50 mA  |

**Table 24: Relay Modules; Non power-limited for mounting in expansion bay only**

| Model     | Description  | Resistive Ratings |                              | Inductive Ratings |                              | Size    | Supv. | Alarm  |
|-----------|--|-------------------|------------------------------|-------------------|------------------------------|---------|-------|--------|
| 4100-3207 | Four double-pole, double-throw (DPDT) switches with feedback | 2 A               | 30 VDC or 30VAC              | 0.5 A             | 30 VDC or 120 VAC            | 1 Block | 18 mA | 65 mA  |
| 4100-3208 | Four double-pole, double-throw (DPDT) switches with feedback | 10 A              | 30 VDC or 120 VAC or 240 VAC | 10 A              | 30 VDC or 120 VAC or 240 VAC | 2 Slots | 20 mA | 188 mA |
| 4100-3209 | Eight single-pole, double-throw (SPDT) switches              | 3 A               | 30 VDC or 120 VAC            | 1.5 A             | 30 VDC or 120 VAC            | 1 Block | 16 mA | 200 mA |

**Table 25: Miscellaneous accessories**

| Model              | Description   |
|--------------------|---|
| 4100-1279          | Single blank 2 in. display cover, 4100-2302 provides a single plate for a full bay        |
| 4100-9856 See note | 4100ES Canadian French Appliqué Kit, Simplex, 4100ES, Contrôle Incendie                   |
| 4100-9857 See note | 4100ES English Appliqué Kit, Simplex, 4100ES, Fire Control                                |
| 4100-9858 See note | 4100ES InfoAlarm Remote Display English Appliqué Kit, Simplex, Operator Interface, 4100ES |

**Table 25: Miscellaneous accessories**

| Model              | Description  |
|--------------------|--|
| 4100-9859 See note | 4100ES InfoAlarm Remote Display Canadian French Appliqué Kit, Simplex, Interface de l'opérateur, 4100ES  |
| 4100-9868          | Special Purpose Appliqué Kit, Simplex, Elevator Recall Control and Supervisory Control Unit, 4100ES  |
| 4100-9869          | Special Purpose Appliqué Kit, Simplex, Sprinkler Waterflow and Supervisory Station, 4100ES   |
| 4100-9835          | Termination and Address Label Kit (for module marking), provides additional labels for field installed modules   |
| 4100-6034          | Tamper Switch, one for each cabinet assembly if required. Monitors solid door for panels with solid door. Monitors the internal retainer panel for panels with glass door (not the glass door), has a built-in addressable IDNet IAM.    |
| 2081-9031          | Series resistor for WSO, IDCs (N.O. water flow and tamper on same circuit, wires after water flow and before tamper) 470 Ω, 1 W, encapsulated, two 18 AWG leads (0.82 mm2 ), 2 1/2 in. L x 1 3/8 in. W x 1 in. H (64 mm x 35 mm x 25 mm) |

**Note:** 4100ES English Appliqués are included with 4100ES Upgrade and Retrofit Kits for mounting 4100ES in 4100, 2120, 2001, and Simplex back boxes so that upgrades can be easily identified as 4100ES. 4100ES Appliqué Kits are available for applications such as:

- to update Remote InfoAlarm Displays connected to a panel that was upgraded to 4100ES
  - for an existing 4100U when the New Master Controller is upgraded to 4100ES and only a software upgrade is required
- When required, French appliqués are ordered separately.

### Network Interface and Network Media Card Product Selection

4100ES fire alarm control units are compatible with Simplex ES Net network or 4120 network fire alarm products.

- Refer to datasheet [S4100-0076](#) for additional information on compatible ES Net fire alarm products.
- Refer to datasheet [S4100-0056](#) for additional information on compatible 4120 fire alarm products.

### Additional 4100ES and network product reference

**Table 26: Additional 4100ES and network product reference**

| Subject  | Data Sheet |
|--|------------|
| Serial DACT (SDACT) for 4100ES, 4010ES, 4007ES   | S2080-0009 |
| Connected Services Gateway - Central Station Communication and SafeLINC Cloud Services | S2080-0091 |
| Battery and Battery Cabinet Reference for 4100ES                                       | S2081-0006 |
| 110 Ah Batteries and Cabinets for 4100ES   | S2081-0012 |
| 4009 IDNet NAC Extender  | S4009-0002 |
| 4009 IDNAC Repeater  | S4009-0004 |
| External 110 Ah Battery Charger for 4100ES, 4010ES                                     | S4081-0002 |
| IDNet Isolator2  | S4090-0017 |
| IDNet Isolator2 Base   | S4098-0026 |
| Graphic I/O Modules for 4100ES, 4010ES, 4007ES   | S4100-0005 |
| Interface to VESDA Air Aspiration Detection Systems                                    | S4100-0026 |
| 4100ES LED/Switch Modules and Printer  | S4100-0032 |
| Master Clock Interface   | S4100-0033 |
| 4100ES Enclosures  | S4100-0037 |
| 4100ES Extinguishing Release Applications  | S4100-0040 |
| TFX Interface Module   | S4100-0042 |
| 2120 BMUX Module   | S4100-0048 |
| Multiple Signal Fiber Optic Modems for 4120 Networks                                   | S4100-0049 |
| BACpac Ethernet Module   | S4100-0051 |
| 4120 Network Products and Specifications   | S4100-0056 |
| Building Network Interface Card (BNIC)   | S4100-0061 |
| SafeLINC Internet Interface  | S4100-0062 |
| Emergency Voice/Alarm Communications Equipment with ES-PS Power Supplies               | S4100-1034 |
| MINIPLX Transponders with ES-PS Power Supplies   | S4100-1035 |
| NDU with ES-PS Power Supplies for 4120 Network   | S4100-1036 |
| 4100ES Remote Annunciator Panels with ES-PS Power Supplies                             | S4100-1039 |
| Remote ES Touch Screen Displays for 4100ES and 4010ES Panels                           | S4100-1070 |
| ES Net Network Products and Specifications   | S4100-1076 |
| NDU with ES-PS Power Supplies for ES Net   | S4100-1077 |
| TrueSite Workstation   | S4190-0016 |
| TrueSite Incident Commander  | S4190-0020 |
| Network System Integrator (NSI) for ES Net and 4120 Networks                           | S4190-0026 |
| 24-Pin Dot Matrix Fire Alarm System Remote Printer                                     | S4190-0027 |
| SCU/RCU Annunciators for 4007ES, 4010ES, 4100ES  | S4602-0001 |
| LCD Annunciator for 4100ES   | S4603-0001 |





## Features

### Simplex 4100ES Box and door options:

- Boxes are available sized for one, two, or three equipment bays, each with a battery bay located at the bottom
- Colors include platinum or red
- Doors are glass front with modular dress panels, or solid
- Models are available with box and door combined for single package shipping, or packaged separately
- Enclosures are NEMA 1 rated; wall mount enclosures are also IP30 rated
- Refer to individual 4100ES data sheets for product application listings, see [Enclosure selection chart](#)

### Door and dress panel selection is coordinated with cabinet function:

- Glass doors with modular dress panels provide visibility of annunciation and interface modules for fire alarm control units (FACU), network display units (NDU), and remote annunciators
- Solid doors are for MINIPLEX Transponders and utility function cabinets where module visibility is not required

### 4100ES enclosure details:

- Latching dress panels easily lift off for internal access
- Smooth box surfaces for locally cutting conduit entrance holes exactly where required
- Alignment markers at the top and bottom of each box side for 6 in. (152 mm) or 4 in. (102 mm) wall studs
- Knockout screw/nail holes are supplied for semi-flush mounting

### Upright cabinet rack packaging reference:

- See Table 3 for cabinet rack listing

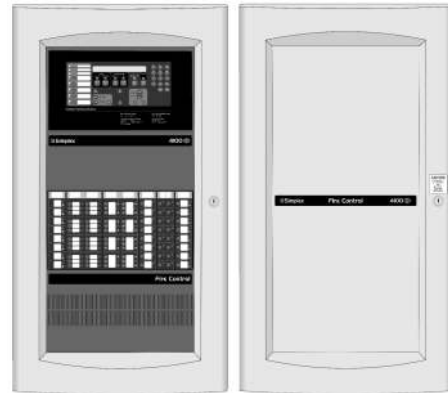

Figure 2: 4100ES Two bay cabinets

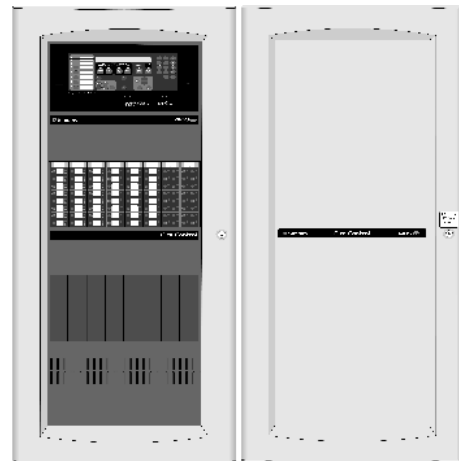

Figure 3: 4100ES Three bay cabinets

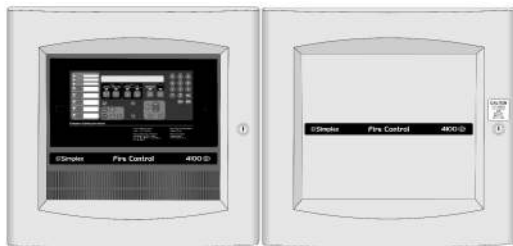

Figure 1: 4100ES One bay cabinet

\* For 4100ES one, two, and three bay cabinets with associated equipment: Products are listed by the California State Fire Marshal (CSFM) pursuant to Section 13144.1 of the California Health and Safety Code. See CSFM Listing 7165-0026:251 for allowable values and/or conditions concerning material presented in this document. Accepted for use – City of New York Department of Buildings – MEA35-93E. Additional listings may be applicable, contact your local Simplex product supplier for the latest status.

## Enclosure selection chart

**Note:** See [Wall mounted enclosure installation reference](#) and for dimensions.

Door keys ship with system master controller.

**Table 1: Combined box and door selection, select if box and door are to be shipped together**

| Description                         | Platinum 1 Bay | Platinum 2 Bay | Platinum 3 Bay | Red 1 Bay | Red 2 Bay | Red 3 Bay |
|-------------------------------------|----------------|----------------|----------------|-----------|-----------|-----------|
| Box with Glass Door and Dress Panel | 2975-9444      | 2975-9445      | 2975-9446      | 2975-9441 | 2975-9442 | 2975-9443 |
| Box with Solid Door                 | 2975-9450      | 2975-9451      | 2975-9452      | 2975-9447 | 2975-9448 | 2975-9449 |

**Table 2: Separate box and door selection, select if boxes and doors are required to be shipped separately**

| Description                | Platinum 1 Bay | Platinum 2 Bay | Platinum 3 Bay | Red 1 Bay | Red 2 Bay | Red 3 Bay |
|----------------------------|----------------|----------------|----------------|-----------|-----------|-----------|
| Box                        | 2975-9438      | 2975-9439      | 2975-9440      | 2975-9407 | 2975-9408 | 2975-9409 |
| Glass Door and Dress Panel | 4100-2104      | 4100-2105      | 4100-2106      | 4100-2124 | 4100-2125 | 4100-2126 |
| Solid Door                 | 4100-2114      | 4100-2115      | 4100-2116      | 4100-2134 | 4100-2135 | 4100-2136 |

**Table 3: Cabinet rack mounting**

| SKU       | Description  |
|-----------|--|
| 4100-2140 | Master controller rack mount kit, <b>one required for each master controller</b>   |
| 4100-2145 | Option bay rack mounting kit, <b>one required for each expansion bay</b>   |
| 4100-2144 | Power distribution module (PDM) rack mount kit, order PDM separately per system voltage, <b>one required for each cabinet rack</b> |

**Table 4: Power distribution modules**

| SKU       | Voltage         | Description  |
|-----------|-----------------|--|
| 4100-0634 | 120 VAC         | Power Distribution Module (PDM); select for each system voltage; <b>one required for each 4100ES box or cabinet rack</b> |
| 4100-0635 | 220/230/240 VAC |  |

**Table 5: Miscellaneous accessories**

| SKU       | Description   |  |
|-----------|---|--|
| 252-019   | Door key, one is shipped with system Master Controller, order for replacement or when extra keys are needed; ("B" key)  |  |
| 4100-9856 | Canadian French Appliqué Kit, for 1, 2, or 3 bay sizes  |  |
| 4100-9857 | 4100ES Appliqué Retrofit Kit, for 1, 2, or 3 bay sizes; use to identify 4100ES features when new door is not used; included with Master Controller Upgrade kits as detailed on data sheet <b>S4100-0031</b> |  |
| 4100-9868 | Special Purpose Appliqué Kit: Simplex , Elevator Recall Control and Supervisory Control Unit, 4100ES  |  |
| 4100-9869 | Special Purpose Appliqué Kit: Simplex , Sprinkler Waterflow and Supervisory Station, 4100ES   |  |
| 4100-9835 | Termination and Address Label Kit, for module marking   | <b>Note:</b> One kit is supplied for each cabinet; order this if required for additional field module installation |
| 4100-9837 | Green LED Power-on Indicator Kit, <b>required for ULC listing of MINIPLEX transponder</b>   | Mounts using knockout provided in solid door   |
| 2975-9813 | Platinum semi-flush box trim  | 1 7/16" in. (37 mm) wide, four corners and trim pieces for top, bottom, and sides                                  |
| 2975-9812 | Red semi-flush box trim   |  |

**Table 6: Battery reference**

| SKU       | Capacity | Battery Notes  |
|-----------|----------|--|
| 2081-9272 | 6.2 Ah   | Sealed lead-acid batteries, 12 VDC each; two required for each battery location. Battery selection is required if batteries are internal. Select one size for each battery set. Refer to data sheet <b>S2081-0006</b> for battery details. |
| 2081-9274 | 10 Ah    |  |
| 2081-9288 | 12.7 Ah  |  |
| 2081-9275 | 18 Ah    |  |
| 2081-9287 | 25 Ah    |  |
| 2081-9276 | 33 Ah    |  |
| 2081-9296 | 50 Ah    |  |

**Table 7: Battery Accessories**

| <b>SKU</b> | <b>Description</b>  |
|------------|---|
| 4100-0650  | Battery Shelf, <b>required for 50 Ah batteries</b>  |
| 4100-5128  | Battery Distribution Terminal Block, mounts to side of box, required for all close-nippled cabinets unless cabinet receives all power from power supplies and batteries located in the adjacent cabinet |

**Wall mounted enclosure installation reference**

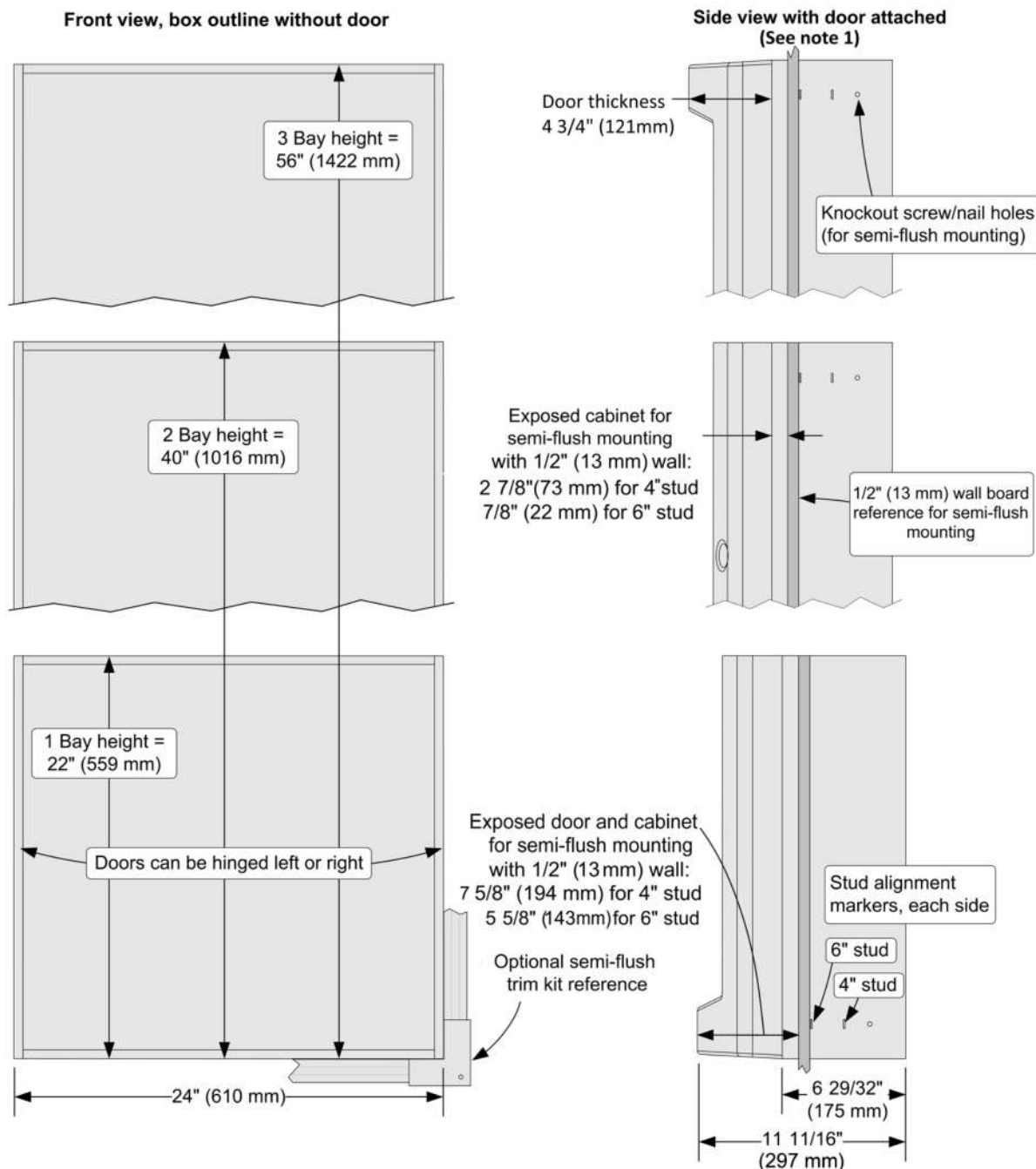

**Figure 4: Installation reference**

**Note:**

- Figure 4 shows side view dimensions with minimal cabinet and door protrusion from the exterior wall. For 6 in. stud construction with minimum protrusion shown, the door opens 90 degrees. To allow the door to open 180 degrees, the exposed cabinet dimension from the exterior wall must be a minimum of 3 in. (76 mm) for both 4 in. and 6 in. stud construction.
- A system ground must be provided for Earth Detection and transient protection devices. This connection shall be made to an approved, dedicated Earth connection for each NFPA 70, Article 250, and NFPA 780.
- For additional installation information refer to Installation Instructions 579-117.

**Additional data sheet reference**

**Table 8: Data sheet reference**

| Subject  | Data Sheet |
|--|------------|
| Graphic I/O Modules for 4100ES, 4010ES, 4007ES   | S4100-0005 |
| 4100ES Basic Panels with SPS Power Supplies      | S4100-0031 |
| 4100ES Emergency Voice/Alarm Equipment           | S4100-0034 |
| MINIPLEX Transponders with SPS Power Supplies    | S4100-0035 |
| NDU with SPS Power Supplies for 4120 Network     | S4100-0036 |
| 4100ES Remote Annunciator Panels                 | S4100-0038 |
| InfoAlarm Command Center with SPS Power Supplies | S4100-0045 |
| NDU with SPS Power Supplies for ES Net           | S4100-0077 |
| 4100ES Basic Panels with EPS Power Supplies      | S4100-0100 |
| InfoAlarm Command Center with EPS Power Supplies | S4100-0101 |
| NDU with EPS Power Supplies for 4120 Network     | S4100-0102 |
| MINIPLEX Transponders with EPS Power Supplies    | S4100-0103 |
| NDU with EPS Power Supplies for ES Net           | S4100-0104 |





## DTK-TSS4D

### Series Connected Surge Protector

DITEK's DTK-TSS4D provides total surge protection solutions for addressable and conventional alarm systems.

The DTK-TSS4D protects dedicated 120VAC power circuits that feed control panels and other critical equipment. It includes dry contacts for remote notification of surge protection status and EMI/RFI filtering to ensure clean power for connected equipment.



### Product Features

- Series design for fast response and best level of protection
- Multi-stage hybrid circuit design
- Diagnostic LED provides positive indication of system power and SPD function
- Form C dry contacts for remote monitoring
- UL1283 EMI/RFI Filtering
- UL Listed NEMA 4X enclosure

### Applications

- Fire Alarm Panels
- Control Panels
- 120Vac Single Phase Critical Loads
- Applications where a UL Listed SPD is required

### Technical Specifications

|   |                             |
|---|-----------------------------|
| <b>Voltage Configuration:</b>                               | 120VAC Single $\Phi$        |
| <b>MCOV:</b>  | 150V                        |
| <b>Protection Modes:</b>                                    | All Modes (L-G, L-N, N-G)   |
| <b>Voltage Protection Rating:</b>                           | 600V L-G, L-N<br>1000V N-G  |
| <b>Surge Current Rating:</b>                                | 50,000 Amps                 |
| <b>Max. Continuous Current:</b>                             | 20 Amps                     |
| <b>SCCR:</b>  | 10kA                        |
| <b>Nominal Discharge Current Rating (<math>I_n</math>):</b> | 3kA                         |
| <b>EMI/RFI Filtering Attenuation:</b>                       | Up to 35dB, 100kHz – 100MHz |

### Mechanical Specifications

|                               |  |
|-------------------------------|--|
| <b>Connection Method:</b>     | Hardwired, series configuration                          |
| <b>Housing:</b>               | Polycarbonate NEMA 4X (IP66)<br>UL94 Flammability Rating |
| <b>Operating Temperature:</b> | 32°F – 140°F (0°C – 40°C)                                |
| <b>Maximum Humidity:</b>      | 95% non-condensing                                       |
| <b>Dimensions:</b>            | 9.5" L X 6.25" W x 3.63" H<br>(241 mm x 159 mm x 92 mm)  |
| <b>Weight:</b>                | 1.8 lb (0.45 kg)   |

### Quality Standards & Approvals

|                              |   |
|------------------------------|---|
| <b>Certifications:</b>       | UL1449 4 <sup>th</sup> Edition<br>cUL, UL1283 |
| <b>SPD Type:</b>             | Type 2  |
| <b>Standards Compliance:</b> | IEEE C62.41.1 –2 and C62.45                   |
| <b>Warranty:</b>             | 10 Year Limited Warranty                      |







**Features**

**Rechargeable, sealed lead-acid batteries**

- Lead-calcium grid structure with immobilized electrolyte in absorbent separator
- Low maintenance with no need to add water
- Low self-discharge characteristics
- One-piece, high-impact polystyrene cell cover with high-reliability dual-seal construction
- UL 924 recognized pressure relief valves

**Battery sizes**

- Batteries for internal mounting from 6.2 Ah to 50 Ah
- Larger batteries, up to 110 Ah, for mounting in external battery cabinets. Models with internal chargers are available.

**Battery cabinets with chargers**

Battery cabinets with chargers communicate with their connected fire alarm control unit (FACU) and are available for 4100ES/4010ES/4100U Series and 4010 Series FACUs.

**Description**

Simplex rechargeable sealed-lead acid batteries provide reliable and repeatable discharge and recharge characteristics for use in fire alarm and other systems applications. They feature immobilized electrolyte in an absorbent separator, which provides rated capacity on the first cycle. Because of their sealed construction, packaging is possible within the system electronics enclosure, see Figure 3. When this is applicable, the quantity of system cabinets and the battery wiring distances are minimized. Where required, external battery cabinets can be close-nipped to the FACU to house larger batteries with battery chargers available in some battery cabinet sizes.

**Battery details**

**Charging:** Compatible with Simplex battery chargers.

**Series connections:** Connect the batteries in series to produce 24 V system voltage. Battery sets must be of identical voltage, model number, appearance, and have approximately the same date of manufacture for optimal operation.

**Testing:** Test battery capacity with a sealed lead-acid battery tester to withdraw a minimum of battery charge. Testing is available through your local Simplex product supplier.

**Shipping:** Sealed lead-acid batteries only ship by ground or sea transportation.

**Disposal:** Battery chemicals and materials can be recycled. Refer to information shipped with the battery or on its case. Return to the manufacturer or to a similarly qualified battery processing facility for proper disposal.

**Seismic activity applications:** Battery brackets are available for systems tested for compliance with specific batteries. Refer to data sheet *S2081-0019* for details.

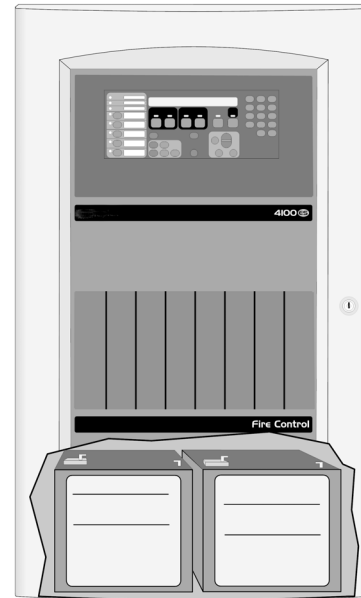

Figure 1: Compatible sealed lead-acid batteries inside an FACU cabinet

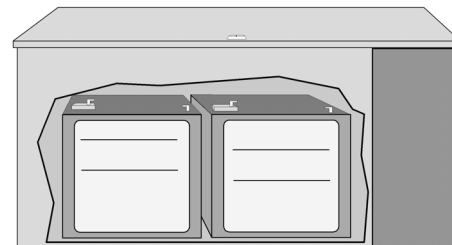

Figure 2: A remote battery cabinet for larger battery requirements

\* Refer to page 4 for battery charger and cabinet agency listings. The batteries detailed in this document meet the requirements of UL, ULC, and Factory Mutual for use with respective equipment battery chargers as listed below. Contact your local Simplex product supplier for proper battery selection per system requirements. Listings and approvals under Simplex Time Recorder Co. are the property of Tyco Fire Protection Products.

### Battery construction reference

Actual appearance varies with battery size.

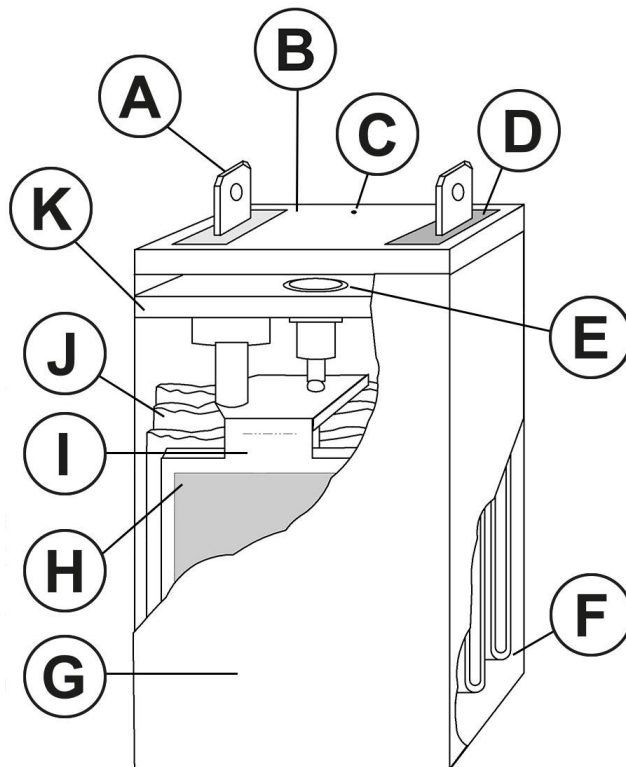

Figure 3: Battery construction reference

| Callout | Description   | Callout | Description   |
|---------|---|---------|---|
| A       | Quick connect or post type terminal. Type varies with battery size. | B       | Sealed outer cover  |
| C       | Vent hole   | D       | Potting material, black for negative, red for positive. Polarity is also clearly marked with + and -. |
| E       | Pressure relief valve   | F       | Semi-permeable membrane separator   |
| G       | Cell case, high impact polystyrene                                  | H       | Lead-calcium grids  |
| I       | Cell group  | J       | Absorbent separator used to immobilize electrolyte  |
| K       | Inner cover   | -       | -   |

### Battery size specifications

| Battery model                                       | Capacity at 20 hour discharge rate | Width*             | Depth*            | Height with terminals | Approximate weight* |
|---|------------------------------------|--------------------|-------------------|-----------------------|---------------------|
| 2081-9272   | 6.2 Ah                             | 6.12 in. (156 mm)  | 2.65 in. (68 mm)  | 4 in. (102 mm)        | 5.75 lb (2.6 kg)    |
| 2081-9286   | 7.0 Ah                             | 6.12 in. (156 mm)  | 2.65 in. (68 mm)  | 4 in. (102 mm)        | 5.75 lb (2.6 kg)    |
| 2081-9274   | 10 Ah                              | 6 in. (153 mm)     | 4.06 in. (103 mm) | 4 in. (102 mm)        | 9.2 lb (4.2 kg)     |
| 2081-9288   | 12.7 Ah                            | 6 in. (153 mm)     | 4 in. (102 mm)    | 4 in. (102 mm)        | 9 lb (4.1 kg)       |
| 2081-9275   | 18 Ah                              | 7.25 in. (184 mm)  | 3.38 in. (86 mm)  | 6.63 in. (168 mm)     | 14.3 lb (6.5 kg)    |
| 2081-9287   | 25 Ah                              | 6.63 in. (168 mm)  | 5 in. (127 mm)    | 7 in. (178 mm)        | 19.4 lb (8.8 kg)    |
| 2081-9271 (rectangular case, typically for service) | 33 Ah                              | 12.5 in. (318 mm)  | 3.38 in. (86 mm)  | 7.06 in. (179 mm)     | 26.6 lb (12.1 kg)   |
| 2081-9276 (square case, use for new)                | 33 Ah                              | 7.75 in. (197 mm)  | 5.25 in. (133 mm) | 6.75 in. (171 mm)     | 26.5 lb (12 kg)     |
| 2081-9296   | 50 Ah                              | 9 in. (229 mm)     | 5.5 in. (140 mm)  | 8.88 in. (225 mm)     | 41.8 lb (19 kg)     |
| 2081-9279   | 110 Ah                             | 11.38 in. (289 mm) | 10.5 in. (267 mm) | 9 in. (230 mm)        | 82 lb (37 kg)       |

\* Dimensions and weight are per battery and are for reference only. Exact size may vary. Refer to [Battery compatibility for FACU mounting](#) and [External battery cabinet compatibility reference](#) for mounting compatibility. Batteries are 12 V each and connected in series for 24 V system use.

**Note:** When wired in series for 24 V output, these batteries are to be of identical voltage, appearance, model number, and have approximately the same date of manufacture.

## General battery specifications

| Specifications                     |                                 |
|------------------------------------|---------------------------------|
| Nominal Voltage Rating             | 12 V                            |
| Discharge Rating                   | 20 hour rate                    |
| Typical Charge/Discharge Cycles    | 100 cycles to 150 cycles        |
| Preferred Charge Temperature Range | 60°F to 90°F (15.6°C to 32.2°C) |

## Battery compatibility for FACU mounting

**Note:** Refer to individual FACU product data sheets for additional battery application information.

**Table 1: Battery compatibility for FACU mounting**

| Simplex FACU model series |          |   |        |               |             |                   |        |        |              |                              |
|---------------------------|----------|---|--------|---------------|-------------|-------------------|--------|--------|--------------|------------------------------|
| Battery Model             | Capacity | 4003EC  | 4004R  | 4007ES & 4005 | 4006 & 4008 | 4009 (all models) | 4010   | 4010ES | 4100ES/4100U | 4100 & 4120 (2, 4 or 6-Unit) |
| 2081-9272                 | 6.2 Ah   | Yes   | Yes    | Yes           | Yes         | Yes               | Yes    | Yes    | Yes          | Yes                          |
| 2081-9286                 | 7.0 Ah   | Yes   | Yes    | Yes           | Yes         | Yes               | Yes    | Yes    | Yes          | Yes                          |
| 2081-9274                 | 10 Ah    | Yes   | Yes    | Yes           | Yes         | Yes               | Yes    | Yes    | Yes          | Yes                          |
| 2081-9288                 | 12.7 Ah  | Yes   | Yes    | Yes           | Yes         | Yes               | Yes    | Yes    | Yes          | Yes                          |
| 2081-9275                 | 18 Ah    | Ext   | Note 3 | Yes           | Ext         | Ext               | Note 2 | Yes    | Yes          | Yes                          |
| 2081-9287                 | 25 Ah    | Ext   | Note 3 | Ext           | Ext         | N/A               | Yes    | Yes    | Yes          | Yes                          |
| 2081-9271 rectangular     | 33 Ah    | Ext   | Note 3 | Ext           | N/A         | N/A               | Note 3 | Yes    | Yes          | Ext                          |
| 2081-9276 square          | 33 Ah    | Ext   | Note 3 | N/A           | N/A         | N/A               | Note 3 | Yes    | Yes          | Yes                          |
| 2081-9296                 | 50 Ah    | N/A   | Note 3 | N/A           | N/A         | N/A               | Note 3 | Note 4 | 2 or 3 bay   | Ext                          |
| 2081-9279                 | 110 Ah   | Requires external battery cabinet, compatible with 4100ES, 4010ES, 4100, and 4120 Series only |        |               |             |                   |        |        |              |                              |

**Yes** = Compatible with included FACU cabinet.

**Ext** = Requires external battery cabinet, refer to [External battery cabinet specification reference](#).

**Note:**

1. These batteries meet the requirements of UL, ULC, and Factory Mutual for use with respective equipment battery chargers listed above. Contact your local Simplex product supplier for proper battery selection per system requirements.
2. 4010 Cabinets accommodate 2081-9275, 18 Ah batteries, but do not allow bottom entry conduit.
3. Use 4081 series companion cabinet and charger, refer to [External battery cabinet specification reference](#).
4. For two bay cabinets only, 50 Ah batteries will fit in the cabinet.

## External battery cabinet compatibility reference

**Table 2: External battery cabinet compatibility reference**

| Battery cabinets without chargers, connected to FACU charger |                                  |                     |                     |                                |                           |                    |                     |
|--|----------------------------------|---------------------|---------------------|--------------------------------|---------------------------|--------------------|---------------------|
| Cabinet  | Panel compatibility              | Battery             |                     |                                |                           |                    |                     |
|  |                                  | 2081-9275<br>18 Ah* | 2081-9287<br>18 Ah* | 2081-9271<br>Rectangular 33 Ah | 2081-9276<br>Square 33 Ah | 2081-9296<br>50 Ah | 2081-9279<br>110 Ah |
| 2081-9280  | 4100ES, 4010ES, 4100U, and 4100+ | N/A                 | N/A                 | N/A                            | N/A                       | N/A                | Yes                 |
| 2081-9281  | multiple                         | Yes                 | Yes                 | Yes                            | Yes                       | Yes                | N/A                 |
| 2081-9282  |                                  | Yes                 | Yes**               | N/A                            | Yes                       | N/A                | N/A                 |
| 4009-9801  | multiple                         | Yes                 | Yes**               | N/A                            | Yes                       | N/A                | N/A                 |

**Table 3: External battery cabinet compatibility reference**

| Battery cabinets with chargers |                          |                     |                     |                                |                           |                           |                     |
|--------------------------------|--------------------------|---------------------|---------------------|--------------------------------|---------------------------|---------------------------|---------------------|
| Cabinet                        | Panel compatibility      | Battery             |                     |                                |                           |                           |                     |
|                                |                          | 2081-9275<br>18 Ah* | 2081-9287<br>18 Ah* | 2081-9271<br>Rectangular 33 Ah | 2081-9276<br>Square 33 Ah | 2081-9296<br>Square 50 Ah | 2081-9279<br>110 Ah |
| 4081-9301                      | 4004R and 4010           | Yes                 | Yes                 | Yes                            | Yes                       | Yes                       | N/A                 |
| 4081-9302                      |                          | Yes                 | Yes                 | Yes                            | Yes                       | Yes                       | N/A                 |
| 4081-9306                      | 4100ES, 4010ES and 4100U | N/A                 | N/A                 | N/A                            | N/A                       | Yes                       | Yes                 |
| 4081-9308                      |                          | N/A                 | N/A                 | N/A                            | N/A                       | Yes                       | Yes                 |

\* Batteries smaller than those listed are normally mounted in the product cabinet

\*\* 25 AH capacity is effective as of 7/2005

**Yes** = Compatible with included FACU cabinet

## External battery cabinet specification reference

**Table 4: Battery cabinets without chargers, shallow design with front door**

| Model      | Color | Listings        | Description   |   | Dimensions  |
|------------|-------|-----------------|---|---|---|
| 2081-9281  | Beige | UL and CSFM     | 2-Unit, 4100 style cabinet without charger; with locking solid door and battery shelf, primarily for use with 50 Ah batteries |   | 25.75 in. W x 20.75 in. H x 6.75 in. D (654 mm x 527 mm x 171 mm) |
| 2081-9282  | Red   | UL              |   |   |   |
| 4003-9860* | Beige | FM              | For use with 4003EC systems, for batteries up to 33 Ah (refer to 4003EC data sheet S4003-0002)                                |   | 9.5 in. H x 24 in. W x 9 in. D (241 mm x 610 mm x 229 mm)         |
| 4009-9801* | Beige | UL, ULC, and FM | For batteries up to 33 Ah   | External battery cabinet without charger, with locking solid door and battery harness; for close-nippled mounting to FACU cabinet | 16.25 in. W x 13.5 in. H x 5.75 in. D (413 mm x 343 mm x 146 mm)* |

\* Depth increased for 2081-9276 square 33 Ah batteries effective 7/2005.

**Table 5: Battery cabinet without charger, deep design with hinged lid**

| Model     | Color | Listings | Description  | Dimensions  |
|-----------|-------|----------|--|---|
| 2081-9270 | Red   | UL       | Battery cabinet without charger; cabinet has vented front, and hinged lid with support rod and lock on top | 26.5 in. W x 12 in. H x 12 in. D (673 mm x 305 mm x 305 mm) |

**Table 6: Chargers for use with 4010 FACUs and 4004R suppression release systems, refer to data sheet S4081-0001**

| Model     | Color | Listings  | Input voltage | Description  | Dimensions   |
|-----------|-------|-----------|---------------|--|--|
| 4081-9301 | Beige | UL and FM | 120 VAC       | Battery cabinet with charger for the 4010 and 4004R FACU, for batteries up to 50 Ah, with front door | 22.5 in. W x 16.75 in. H x 8.38 in. D (572 mm x 425 mm x 213 mm) |
| 4081-9302 | Red   |           |               |  |  |

**Table 7: Battery cabinet without charger for 110 Ah batteries, for use with compatible FACU mounted chargers, refer to data sheet S2081-0012**

| Model and listing | Color | Listings      | Cabinet description   | Compatible chargers                 | Charger description  | Dimensions  |
|-------------------|-------|---------------|---|-------------------------------------|--|---|
| 2081-9280         | Red   | UL, ULC, CSFM | Battery cabinet without charger for 2081-9279, 110 Ah batteries. Includes 80 A battery fuse, terminals and battery connection cables. See data sheet for details. | 4100-9xxx Series                    | 4100ES/4100U Power Supplies for Master Controller/CPU Bays | 26.5 in. W x 12 in. H x 12 in. D (673 mm x 305 mm x 305 mm) |
|                   |       |               |   | 4100-5401                           | 4100ES Additional ES Power Supply (ES-PS)                  |   |
|                   |       |               |   | 4100-5111<br>4100-5113              | 4100ES/4100U Additional SPS                                |   |
|                   |       |               |   | 4100-5311<br>4100-5313              | 4100ES Additional EPS+                                     |   |
|                   |       |               |   | 4100-5325<br>4100-5327              | 4100ES Additional EPS                                      |   |
|                   |       |               |   | 4100-5125<br>4100-5127              | 4100ES/4100U Remote Power Supply (RPS)                     |   |
|                   |       |               |   | 4100-5120<br>4100-5122              | 4100ES/4100U TrueAlert Addressable Power Supply (TPS)      |   |
|                   |       |               |   | 4100-0104<br>4100-0114<br>4100-0124 | 4100 legacy power supplies                                 |   |

**Table 8: Battery cabinet with charger for 110 Ah batteries, for use with compatible FACU mounted chargers, refer to data sheet S2081-0012**

| Model     | Color   | Listings               | Input voltage                 | Description   | Dimensions  |
|-----------|---|------------------------|-------------------------------|---|---|
| 4081-9306 | Red   | UL, ULC, FM, MEA (NYC) | 120 VAC                       | Battery cabinet with charger for batteries up to 110 Ah | 27.88 in. W x 13.5 in. H x 14.63 in. D (708 mm x 343 mm x 371 mm) |
| 4081-9308 | Red   | UL, ULC, FM            | 220/230/240 VAC, multi-tapped |   |   |
| 4100-9837 | Green LED Power-on Indicator Kit, required for ULC listing, mounts above access panel using knockout provided |                        |                               |   |   |

## Features

### TrueAlarm analog sensing provides the following features

- Digital transmission of analog sensor values using IDNet or MAPNET II two-wire communications

### For use with the following Simplex products

- 4007ES, 4010, 4010ES, 4100ES, and 4100U Series control units ; and 4008 Series control units with reduced feature set (refer to data sheet *S4008-0001* for details)
- 4020, 4100, and 4120 Series control units, Universal Transponders, and 2120 TrueAlarm CDTs equipped for MAPNET II operation

### Fire alarm control unit provides the following features

- Peak value logging with accurate analysis of each sensor for individual sensitivity selection
- Sensitivity monitoring meets NFPA 72 sensitivity testing requirements; automatic individual sensor calibration check verifies sensor integrity
- Automatic environmental compensation, multi-stage alarm operation, and display of sensitivity directly in percent for each foot
- Display and print detailed sensor information in plain English language

### Photoelectric smoke sensors provide the following features

- Sensitivity levels from 0.2% to 3.1%. See [TrueAlarm sensors](#) for more information.

### Heat sensors have these features

- Three fixed temperature sensing thresholds: 135°F, 155°F and 190°F
- Rate-of-rise temperature sensing
- Utility temperature sensing
- Listed to UL 521 and ULC-S530

### General features

- Ceiling or wall mounting
- Listed to UL 268 7th Edition and ULC-S529
- NEMA 1 rated. See [TrueAlarm analog sensing product selection chart](#) for more information.
- Louvered smoke sensor design enhances smoke capture by directing flow to chamber; entrance areas are minimally visible when ceiling mounted
- Designed for EMI compatibility
- Magnetic testing
- Different bases support a supervised or unsupervised output relay, or a remote LED alarm indicator

### Additional base reference

- For isolator bases, refer to data sheet *S4098-0025*
- For sounder bases, refer to data sheet *S4098-0028*
- For photo/heat sensors, refer to data sheet *S4098-0024* , single address and *S4098-0033* , dual address

## Description

### Digital communication of analog sensing

TrueAlarm analog sensors provide an analog measurement digitally communicated to the host control panel using Simplex addressable communications. The control unit analyses the data, determines an

average value and stores it. Comparing the sensor's present value against its average value and time, determines an alarm or other abnormal condition.

### Intelligent data evaluation

Monitoring each sensor's average value provides a continuously shifting reference point. A software filtering process compensates for environmental factors, such as dust and dirt, and component aging, to provide an accurate reference for evaluating new activity. This filtering reduces the probability of false or nuisance alarms caused by shifts in sensitivity, either up or down.

### Control unit selection

The control unit stores peak activity for each sensor to assist in evaluating specific locations. The host control unit determines the alarm set point for each TrueAlarm sensor, selectable as more or less sensitive as the individual application requires.

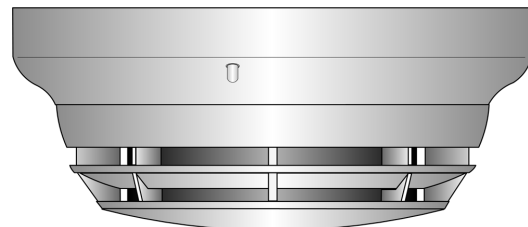

Figure 1: 4098-9714 TrueAlarm photoelectric sensor mounted in base

### Timed/multi-stage selection

You can program the sensor alarm set points for timed automatic sensitivity selection, such as more sensitive at night, less sensitive during day. You can program the control unit to provide multi-stage operation for each sensor.

### Sensor alarm and trouble LED indication

Each sensor base's LED pulses to indicate communications with the unit. If the control unit determines a sensor is in alarm, is dirty, or has some other type of trouble, the details are annunciated at the control unit and the sensor's base LED will turn on steadily. During a system alarm, the control unit will control the LEDs such that an LED indicating a trouble will return to pulsing to help identify the alarmed sensors.

## TrueAlarm sensor bases and accessories

### Sensor base features

#### Base mounted address selection

- Address remains with its programmed location
- Accessible from front, DIP switch under sensor

#### General features

- Automatic identification provides default sensitivity when substituting sensor types
- Integral red LED for power-on, pulsing, or alarm or trouble, steady on
- Locking anti-tamper design mounts on standard outlet box
- Magnetically-operated functional test

\* These products have been approved by the California State Fire Marshal (CSFM) pursuant to Section 13144.1 of the California Health and Safety Code. See CSFM Listings 7272-0026:218, 7271-0026:231, 7270-0026:216, and 7300-0026:217 for allowable values and/or conditions concerning material presented in this document. Additional listings may be applicable, contact your local Simplex product supplier for the latest status. Listings and approvals under Simplex Time Recorder Co. are the property of Tyco Fire Protection Products.

## Sensor bases

### 4098-9792, standard sensor base

### 4098-9789, sensor base with wired connections

- 2098-9808 remote LED alarm indicator or 4098-9822 relay (relay is unsupervised and requires separate 24 VDC)

### Supervised relay bases not compatible with 2120 CDT:

- **4098-9791, 4-wire sensor base**, use with remote or locally mounted 2098-9737 relay, requires separate 24 VDC
- **4098-9780, 2-wire sensor base**, use with remote or locally mounted 4098-9860 relay, no separate power required
- Supervised relay operation is programmable and can be manually operated from control unit
- Includes wired connections for remote LED alarm indicator **or** 4098-9822 relay, relay is unsupervised and requires separate 24 VDC

## Sensor base options

### 2098-9737, remote or local mount supervised relay

- DPDT contacts for resistive/suppressed loads
- power limited rating of 3 A at 28 VDC
- non-power limited rating of 3 A at 120 VAC, requires external 24 VDC coil power

### 4098-9860, remote or local mount supervised relay

- SPDT dry contacts, power limited rating of 2 A at 30 VDC, resistive; non-power limited rating of 0.5 A at 125 VAC, resistive

### 4098-9822, LED annunciation relay

- Activates when base LED is on steady, indicating local alarm or trouble
- DPDT contacts for resistive/suppressed loads, power limited rating of 2 A at 28 VDC; non-power limited rating of 1/2 A at 120 VAC, (requires external 24 VDC coil power)

### 4098-9832, adapter plate

- Required for surface or semi-flush mounting to 4 in. square electrical box and for surface mounting to 4 in. octagonal box
- Can be used for cosmetic retrofitting to existing 6 3/8 in. diameter base product

### 2098-9808, remote red LED alarm indicator

- Mounts on single gang box



Figure 2: Remote red LED alarm indicator

## Description

TrueAlarm sensor bases contain integral addressable electronics that constantly monitor the status of the detachable photoelectric or heat sensors. Each sensor's output is digitized and transmitted to the system fire alarm control unit every four seconds.

You can easily interchange different TrueAlarm sensor types to meet specific location requirements. This feature allows intentional sensor substitution during building construction. When conditions are temporarily dusty, you can install heat sensors without reprogramming the control unit, as covering smoke sensors causes them to be disabled. Although the control unit will indicate an incorrect sensor type, the heat sensor will operate at a default sensitivity providing heat detection for building protection at that location.

## Mounting reference

### Electrical Box Requirements: (boxes are by others)

**Without relay in the box:** 4" octagonal or 4" square, 1-1/2" deep; single gang, 2" deep

**With relay in the box:** 4" octagonal or 4" square, 1-1/2" deep, with 1-1/2" extension ring

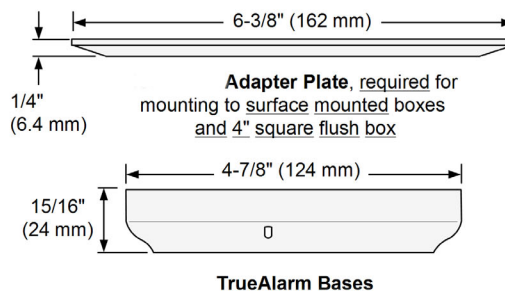
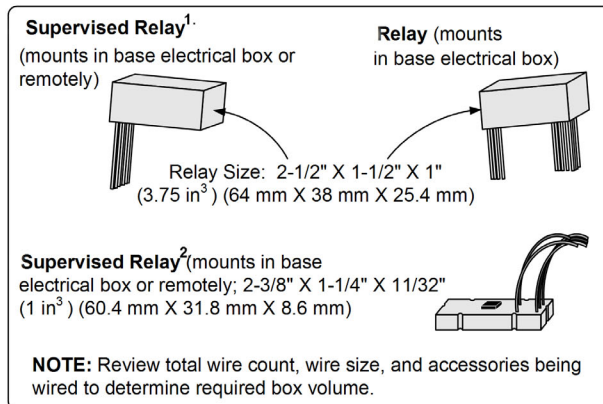
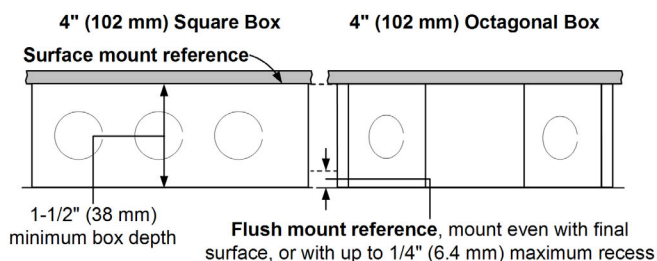

Figure 3: Mounting reference

Table 1: Product mounting - SKU reference

| Product          | SKU   |
|------------------|---|
| Relay            | 4098-9822                                     |
| Supervised relay | Example 1 2098-9739<br>Example 2 4098-9860    |
| Adapter plate    | 4098-9832                                     |
| TrueAlarm bases  | 4098-9780, 4098-9789, 4098-9791,<br>4098-9792 |

## TrueAlarm sensors

### Features

- Sealed against rear air flow entry
- Interchangeable mounting
- EMI/RFI shielded electronics
- Heat sensors:
  - Selectable rate compensated, fixed temperature sensing with or without rate-of-rise operation
  - Rated spacing distance between sensors:

| Fixed Temp. Setting            | UL and ULC Spacing        | FM Spacing, Either Fixed Temperature Setting  |
|--------------------------------|---------------------------|---|
| 135°F (57.2°C)<br>190°F (88°C) | 60 ft x 60 ft<br>(18.3 m) | 20 ft x 20 ft (6.1 m) for fixed temperature only; RTI = Quick                                     |
| 155°F (68°C)                   | 40 ft x 40 ft<br>(12.2 m) | 50 ft x 50 ft (15.2 m) for fixed temperature with either rate-of-rise selection; RTI = Ultra Fast |

**Note:** 190°F (88°C) ratings apply only to the 4098-9734 sensor.

### Smoke sensors

- Photoelectric technology sensing
- 360° smoke entry for optimum response
- Built-in insect screens

### 4098-9714 photoelectric sensor

TrueAlarm photoelectric sensors use a stable, pulsed LED light source and a silicon photodiode receiver to deliver consistent and accurate low power smoke sensing. There are three user-selectable sensitivities for special applications for each individual sensor: 0.2%, 0.5%, and 1% for each foot. Standard sensitivity is 1.25% to 3.1% for each foot. The fire alarm control unit runs an algorithm that can vary the sensitivity for normal applications between 1.25% and 3.1% for each foot.

**Note:** Fixed sensitivity settings higher than 1.0% for each foot are not UL268 7th Edition compliant.

The sensor head design provides 360° smoke entry for optimum response to smoke from any direction. Due to its photoelectric operation, air velocity is not normally a factor, except for impact on area smoke flow.

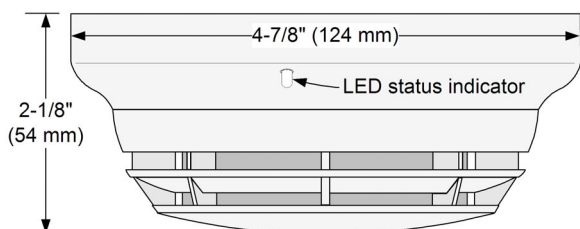

Figure 4: 4098-9714 photoelectric sensor with base

### 4098-9733 and 4098-9734 heat sensors

TrueAlarm heat sensors are self-restoring and provide rate-compensated, fixed temperature sensing, you can select with or without rate-of-rise temperature sensing. Due to its small thermal mass, the sensor accurately and quickly measures the local temperature for analysis at the fire alarm control unit.

You can select rate-of-rise temperature detection at the control unit for either 15°F or 20°F (8.3°C or 11.1°C) for each minute. Fixed temperature sensing is independent of rate-of-rise sensing and you can program it to operate at 135°F or 155°F (57.2°C or 68°C). The 4098-9734 sensor provides an additional 190°F (88°C) set point.

In a slowly developing fire, the temperature may not increase rapidly enough to operate the rate-of-rise feature. However, an alarm will be initiated when the temperature reaches its rated fixed temperature setting.

You can program TrueAlarm heat sensors as a utility device to monitor for temperature extremes in the range of 32°F to 155°F (0°C to 68°C). This feature can provide freeze warnings, or alert you to HVAC system problems. Refer to panel specifications for availability.

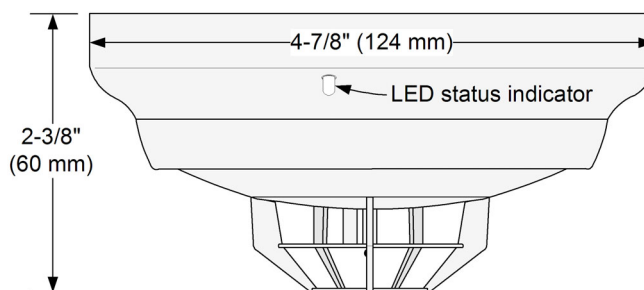

Figure 5: 4098-9733 heat sensor with base

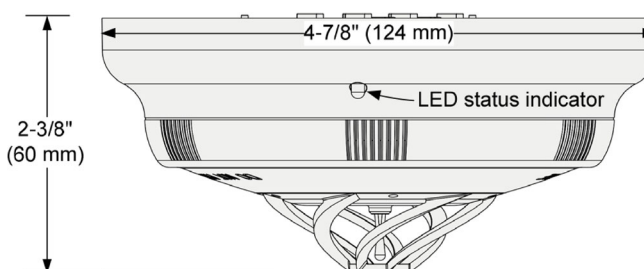

Figure 6: 4098-9734 high temperature heat sensor with base

**WARNING:** In most fires, hazardous levels of smoke and toxic gas can build up before a heat detection device would initiate an alarm. In cases where Life Safety is a factor, the use of smoke detection is highly recommended.

### Application reference

Sensor locations should be determined only after careful consideration of the physical layout and contents of the area to be protected. Refer to NFPA 72, *the National Fire Alarm and Signaling Code*. On smooth ceilings, a smoke sensor spacing of 30 ft (9.1 m) can be used as a guide.

For detailed application information including sensitivity selection, refer to *Installation Instructions 574-709*.



**TrueAlarm analog sensing product selection chart**
**Table 2: TrueAlarm sensor bases (for use with sensors 4098-9714 and 4098-9733)**

| SKU   | Color | Description  | Compatibility  | Mounting requirements   |
|---|-------|--|--|---|
| 4098-9792<br>GSA4098-9792                                     | White | Standard sensor base   | No options   | 4 in. octagonal or 4 in. square box, 1 1/2 in. min. depth; or single gang box, 2 in. min. depth             |
| 4098-9776   | Black |  |  |   |
| 4098-9789<br>4098-9789IND<br>GSA4098-9789                     | White | Sensor base with connections for remote LED alarm indicator <b>or</b> unsupervised relay     | 2098-9808 remote alarm indicator or 4098-9822 unsupervised relay | 4 in. octagonal or 4 in. square box   |
| 4098-9775   | Black |  |  |   |
| 4098-9791   | White | 4-wire sensor supervised relay base with connections for LED indicator or unsupervised relay | 2098-9737 supervised remote relay                                | <b>Note:</b><br>Box depth requirements depend on total wire count and wire size, see Table 4 for reference. |
| <b>Note:</b> NOT compatible with the 2120 CDT                 |       |  | 2098-9808 remote alarm indicator or 4098-9822 unsupervised relay |   |
| 4098-9780   | White | 2-wire sensor supervised relay base with connections for LED indicator or unsupervised relay | 4098-9860 supervised remote relay                                |   |
| GSA4098-9780<br><b>Note:</b> NOT compatible with the 2120 CDT |       |  | 2098-9808 remote alarm indicator or 4098-9822 unsupervised relay |   |

**Note:** SKU numbers ending in IND are assembled in India. SKU numbers with GSA prefix are assembled in the USA.

Refer to *Application Manual 574-709* and *Installation Instructions 574-707* for additional information.

**Table 3: TrueAlarm sensors**

| SKU  | Color | Description                  | Compatibility  | Mounting requirements      |
|--|-------|------------------------------|--|----------------------------|
| 4098-9714<br>4098-9714-IND<br>GSA4098-9714 | White | Photoelectric smoke sensor   | Bases 4098-9775, 4098-9776, 4098-9792, 4098-9789, 4098-9791, and 4098-9780 | Refer to base requirements |
| 4098-9774                                  | Black |                              |  |                            |
| 4098-9733<br>GSA4098-9733                  | White | Heat sensor                  |  |                            |
| 4098-9778                                  | Black |                              |  |                            |
| 4098-9734<br>GSA4098-9734                  | White | High temperature heat sensor |  |                            |

**Note:**

- All of these SKUs are NEMA 1 rated.
- The 4098-9734 Heat Sensor is compatible with IDNet on the 4100ES, 4010ES, and 4007ES only.
- SKU numbers with GSA prefix are assembled in the USA.

**Table 4: TrueAlarm sensor/base accessories**

| SKU       | Description   | Compatibility  | Mounting requirements   |
|-----------|---|--|---|
| 2098-9737 | Supervised relay, mounts remote or in base electrical box                                       | For use with 4098-9791 base                          | Remote mounting requires 4 in. octagonal or 4 in. square box, 1 1/2 in. minimum depth                   |
| 4098-9860 | Supervised relay, mounts remote or in base electrical box                                       | For use with 4098-9780 base                          | Base mounting requires 4 in. octagonal box, 2 1/8 in. deep with 1 1/2 in. extension ring                |
| 2098-9808 | Remote red LED alarm indicator on single gang stainless steel plate                             | Bases 4098-9789, 4098-9791, and 4098-9780            | Single gang box, 1 1/2 in. minimum depth  |
| 4098-9822 | Unsupervised relay, tracks base led status.<br><b>Note:</b> Mounts only in base electrical box. | Bases 4098-9789, 4098-9791, and 4098-9780            | 4 in. octagonal box, 2 1/8 in. deep with 1 1/2 in. extension ring                                       |
| 4098-9832 | Adapter plate   | Bases 4098-9792, 4098-9789, 4098-9791, and 4098-9780 | Required for surface or semi-flush mounted 4 in. square box and for surface mounted 4 in. octagonal box |

**Note:** 2098-9808 is NEMA 1 rated.

## Specifications

**Table 5: General operating specifications**

| Specification                                    | Rating  |                             |
|--|---|-----------------------------|
| Communications and sensor supervisory power      | IDNet or MAPNET II communications, auto-selected, one address for each base                   |                             |
| Communications connections                       | Screw terminals for in/out wiring, 18 to 14 AWG, 0.82 mm <sup>2</sup> to 2.08 mm <sup>2</sup> |                             |
| Remote LED alarm indicator current               | 1 mA typical, no impact to alarm current  |                             |
| Remote LED alarm indicator and relay connections | Color coded wire leads, 18 AWG, 0.82 mm <sup>2</sup>  |                             |
| UL listed operating temperature range            | 32°F to 100°F, 0°C to 38°C  |                             |
| Operating temperature range                      | with 4098-9733 Heat Sensor  | 32°F to 122°F, 0°C to 50°C  |
|  | with 4098-9714 Smoke Sensor   | 15°F to 122°F, -9°C to 50°C |
|  | with 4098-9734 Heat Sensor  | 32°F to 150°F, 0°C to 66°C  |
| Storage temperature range                        | 0°F to 140°F, -18°C to 60°C   |                             |
| Humidity range                                   | 10% to 95% RH   |                             |
| 4098-9714 smoke sensor air velocity rating       | 0 to 4000 ft/min, 0 to 1220 m/min   |                             |
| Housing color                                    | Frost white or black  |                             |

**Table 6: 4098-9791 Base with supervised remote relay 2098-9737**

| Specification   | Rating                           |
|---|----------------------------------|
| Externally supplied relay coil voltage                                    | 18 VDC to 32 VDC, nominal 24 VDC |
| Supervisory current   | 270 µA, from 24 VDC supply       |
| Alarm current with 2098-9737 relay  | 28 mA, from 24 VDC supply        |
| <b>Note:</b> See <a href="#">Sensor base options</a> for contact ratings. |                                  |

**Table 7: 4098-9780 Base with supervised remote relay 4098-9860**

| Specification | Rating                       |
|---------------|------------------------------|
| Power         | Supplied from communications |

**Table 8: 4098-9822 Unsupervised relay, requirements for bases 4098-9789, 4098-9791, and 4098-9780**

| Specification   | Rating                            |
|---|-----------------------------------|
| Externally supplied relay coil voltage                                    | 18 VDC to 32 VDC, nominal 24 VDC  |
| Supervisory current   | Supplied from communications      |
| Alarm current   | 13 mA from separate 24 VDC supply |
| <b>Note:</b> See <a href="#">Sensor base options</a> for contact ratings. |                                   |



## Features

### Individually addressable manual fire alarm stations with:

- Power and data supplied by IDNet or MAPNET II addressable communications using a single wire pair
- Operation that complies with ADA requirements
- Visible LED indicator that flashes during communications and is on steady when the station has been activated
- The NO GRIP Single Action Station and Retrofit Kit are available with a more easily operated pull lever for applications where anticipated users may find the standard station lever difficult to activate
- Pull lever that protrudes when alarmed
- Break-rod supplied (use is optional)
- Models are available with single or double action (breakglass or push) operation
- UL listed to Standard 38
- NEMA 1 rated. See [Addressable manual station product selection](#) for more information.

### Compatible with the following Simplex control panels:

- Model Series 4007ES, 4008, 4010, 4010ES, 4100ES, 4100U, 4020, 4100, and 4120 fire alarm control panels equipped with either IDNet or MAPNET II communications
- Model Series 2120 Communicating Device Transponders (CDTs) equipped with MAPNET II communications

### Compact construction:

- Electronics module enclosure minimizes dust infiltration
- Allows mounting in standard electrical boxes
- Screw terminals for wiring connections

### Tamper resistant reset key lock, keyed same as Simplex fire alarm cabinets.

### Multiple mounting options:

- Surface or semi-flush with standard boxes or matching Simplex boxes
- Flush mount adapter kit
- Adapters are available for retrofitting to commonly available existing boxes

## Description

The Simplex addressable manual station combines the familiar Simplex manual station housing with a compact communication module that is easily installed to satisfy demanding applications. Its integral individual addressable module (IAM) constantly monitors status and communicates changes to the connected control panel through IDNet or MAPNET II communications wiring.

## Operation

**Activation** of the 4099-9004 single action manual station requires a firm downward pull to activate the alarm switch. Completing the action breaks an internal plastic break-rod which is visible below the pull lever, use is optional. The use of a break-rod can be a deterrent to vandalism without interfering with the minimum pull requirements needed for easy activation. The pull lever latches into the alarm position and remains extended out of the housing to provide a visible indication.

**Single Action NO GRIP Station 4099-9021.** For applications such as California Building Code, Title 24, which requires "Controls and operating mechanisms shall be operable with one hand and shall not require tight grasping, pinching or twisting of the wrist" the model 4099-9021 station provides a more easily operated pull lever compared to standard stations. Retrofit of existing stations is available using the 4099-9805 Retrofit kit.

**Double Action Stations (Breakglass)** require the operator to strike the front mounted hammer to break the glass and expose the recessed pull lever. The pull lever then operates as a single action station.



4099-9004  
Single action



4099-9021 NO  
GRIP Single action



4099-9805 NO  
GRIP Retrofit kit



4099-9005 Breakglass



4099-9006 Push



With 2099-9828  
Institutional Cover kit

**Double Action Stations (Push Type)** require that a spring loaded interference plate, marked PUSH, be pushed back to access the pull lever of the single action station.

**Station reset** requires the use of a key to reset the manual station lever and deactivate the alarm switch. If you use the break-rod, you must replace it.

**Station testing** is performed by physical activation of the pull lever. You can also perform electrical testing by unlocking the station housing to activate the alarm switch.

**Specifications**

Refer to 4099 MAPNET II/ IDNet Addressable Manual Pull Station with LED Installation Instructions 579-1135 for additional information.

**Table 1: Specifications**

| Specification                      | Rating  |
|------------------------------------|---|
| <b>Power and communications</b>    | IDNet or MAPNET II communications, 1 address for each station   |
| <b>Address means</b>               | DIP switch, 8 position  |
| <b>Wire connections</b>            | Screw terminal for in/out wiring, for 18 AWG to 14 AWG wire (0.82 mm <sup>2</sup> to 2.08 mm <sup>2</sup> ) |
| <b>UL listed temperature range</b> | 32°F to 120°F (0°C to 49°C) intended for indoor operation   |
| <b>Humidity range</b>              | Up to 93% RH at 100°F (38°C)  |
| <b>Housing color</b>               | Red with white raised lettering   |
| <b>Material</b>                    | Housing and pull lever are Lexan polycarbonate or equal   |
| <b>Pull lever color</b>            | White with red raised lettering   |
| <b>Housing dimensions</b>          | 5 in. H x 3 3/4 in. W x 1 in. D (127 mm x 95 mm x 25 mm)  |

**Addressable manual station semi-flush mounting**

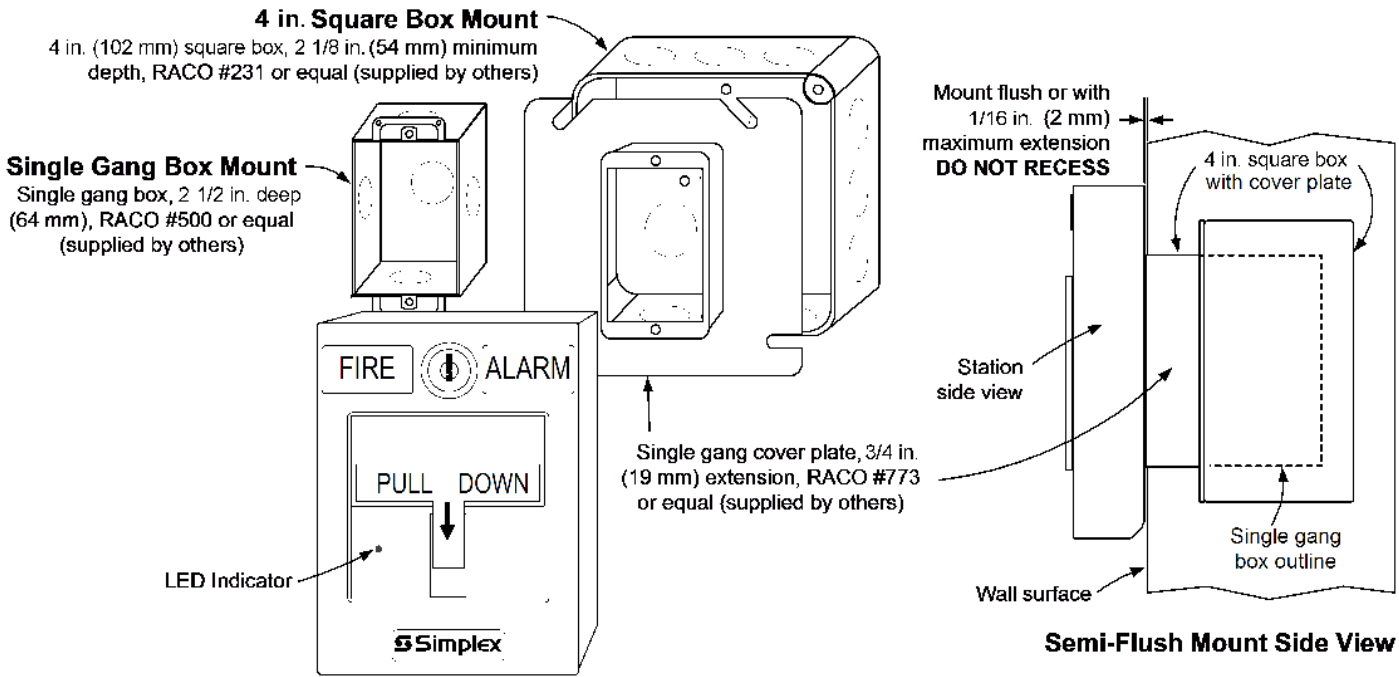

Figure 1: Addressable manual station semi-flush mounting

**Addressable manual stations surface mounting**

**Preferred mounting.** For surface mounting of these addressable manual stations, the preferred electrical boxes are shown in Figure 2.

**Additional mounting reference.** See [Addressable manual station, additional mounting information](#) for Wiremold box mounting compatibility.

Figure 2 shows the 2975-9178 box and the 2975-9022 cast box.

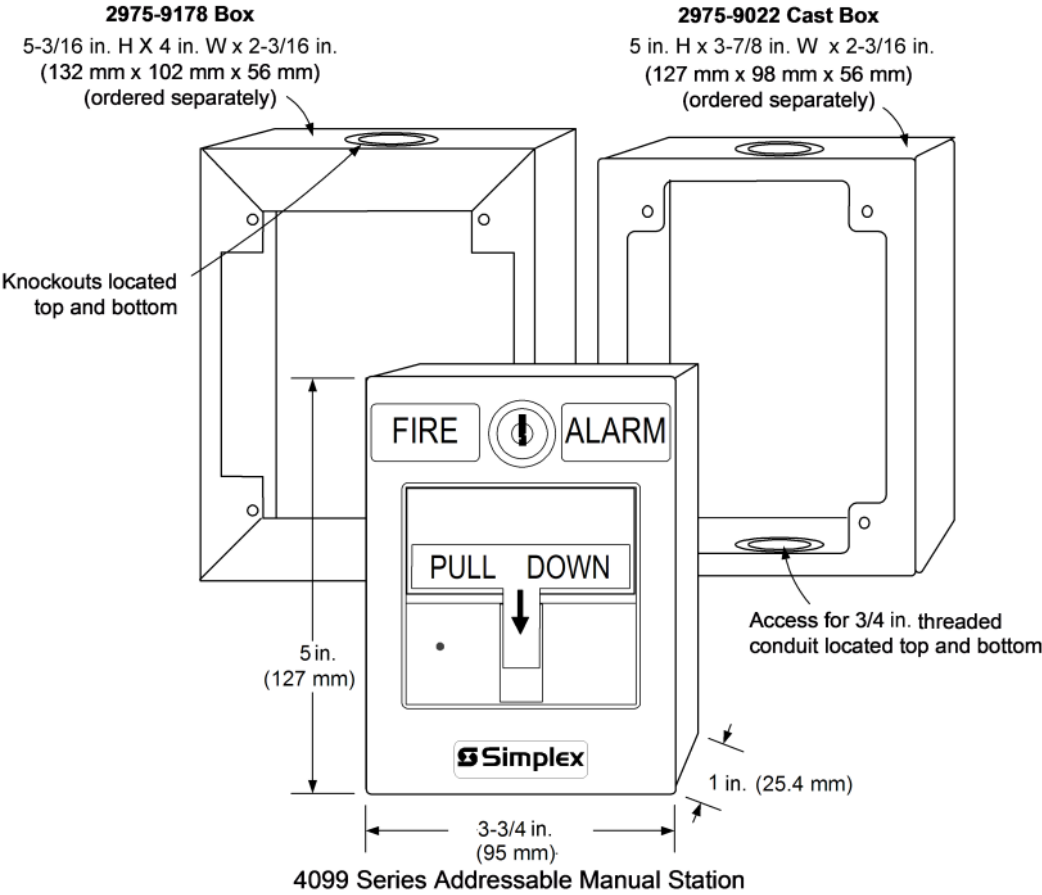

Figure 2: 4099 Series addressable manual station

### Surface mount side view with internal detail

Figure 3 shows the 2975-9178 box.

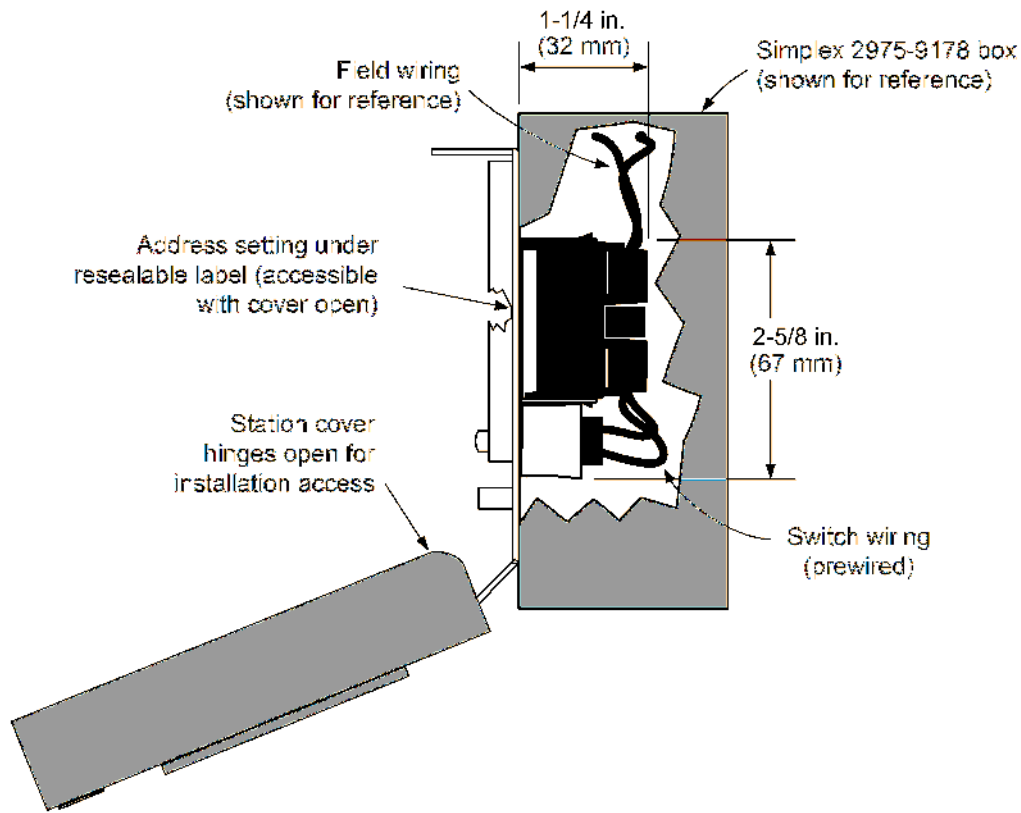

Figure 3: Surface mount side view with internal detail

### Application reference

Refer to NFPA 72, the *National Fire Alarm and Signaling Code*, and all applicable local codes for complete requirements for manual stations. The following summarizes the basic requirements:

1. Stations shall be located in the normal path of exit and distributed in the protected area such that they are unobstructed and readily accessible.
2. Mounting shall be with the operable part not less than 42 in. (1.07 m) and not more than 48 in. (1.22 m) above floor level.
3. At least one station shall be provided on each floor. Additional stations shall be provided to obtain a travel distance not more than 200 ft (61 m) to the nearest station from any point in the building.
4. When manual station coverage appears limited in any way, additional stations should be installed.

**Addressable manual station, additional mounting information**

For retrofit and new installations, additional compatible mounting boxes and the required adapter plates are shown in Figure 4. Figure 4 shows the 2099-9814 surface trim for Wiremold boxes and the 2099-9813 semi-flush trim for 2 gang switch boxes.

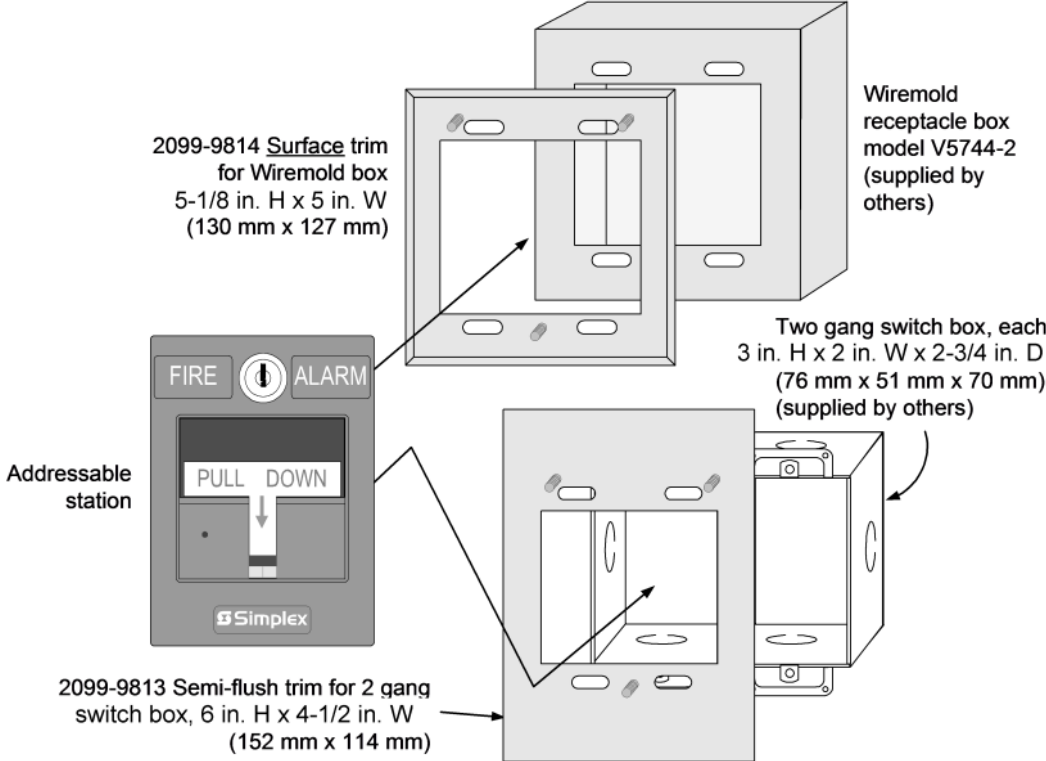

Figure 4: Addressable manual station, additional mounting information

**Addressable manual station, flush mounting information**

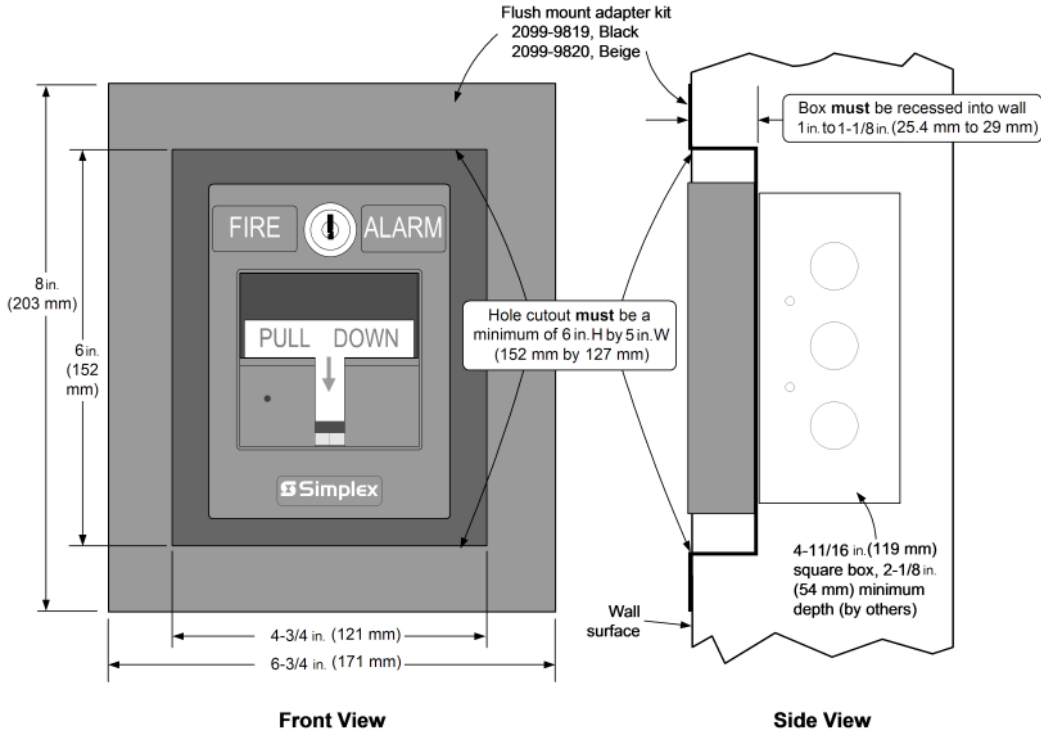

Figure 5: Addressable manual station, flush mounting information

The flush mount adapter kit is available in beige (2099-9820) or black (2099-9819).



## Addressable manual station product selection

**Table 2: Addressable manual station product selection red housing with white letters and white pull lever**

| Model                 | Description                                     | Housing      | Pull lever     | Listings          |
|-----------------------|---|--------------|----------------|-------------------|
| 4099-9004, see note   | Single Action, English                          | FIRE ALARM   | PULL DOWN      | UL, ULC, FM, CSFM |
| 4099-9004CB, see note | Single Action, Bilingual English and French     | FEU FIRE     | TIREZ PULL     | ULC               |
| 4099-9004CF, see note | Single Action, French                           | ALARME FEU   | ABAISSÉZ       |                   |
| 4099-9004PO, see note | Single Action, Portuguese                       | FOGO ALARME  | PUXE           | UL, FM            |
| 4099-9004SP, see note | Single Action, Spanish                          | ALARMA FUEGO | JALE           |                   |
| 4099-9005, see note   | Double Action, Breakglass operation, English    | FIRE ALARM   | PULL DOWN      | UL, ULC, FM, CSFM |
| 4099-9005PO, see note | Double Action, Breakglass operation, Portuguese | FOGO ALARME  | PUXE           | UL, FM            |
| 4099-9005SP, see note | Double Action, Breakglass operation, Spanish    | ALARMA FUEGO | JALE           |                   |
| 4099-9006, see note   | Double Action, Push operation, English          | FIRE ALARM   | PUSH PULL DOWN | UL, ULC, FM, CSFM |
| 4099-9006PO, see note | Double Action, Push operation, Portuguese       | FOGO ALARME  | EMPURRE PUXE   | UL, FM            |
| 4099-9006SP, see note | Double Action, Push operation, Spanish          | ALARMA FUEGO | EMPUJE JALE    |                   |
| 4099-9021, see note   | Single Action NO GRIP operation, English        | FIRE ALARM   | PULL DOWN      | UL, ULC, FM, CSFM |

**Note:** NEMA 1 rated when used with 2975-9178 back box.

**Table 3: Accessories**

| Model     | Description  |
|-----------|--|
| 2975-9022 | Cast aluminum surface mount box, red   |
| 2975-9178 | Surface mount steel box, red   |
| 2099-9813 | Semi-flush trim plate for double gang switch box, red  |
| 2099-9819 | Flush mount adapter kit, black   |
| 2099-9820 | Flush mount adapter kit, beige   |
| 4099-9805 | Retrofit Kit for field conversion of a single action station to a NO GRIP station; refer to the <i>NO GRIP Actuator (4099-9805) Installation Instructions 579-1007</i> for details |
| 2099-9803 | Replacement breakglass   |
| 2099-9804 | Replacement break-rod  |
| 2099-9828 | Institutional cover kit for field installation on 4099-9004;<br><b>Note:</b> Covers LED indicator  |
| 2099-9814 | Surface trim plate for Wiremold box V5744-2, red   |
| 2099-9822 | Replacement retaining clip for breakglass  |
| 252-019   | B key for manual station reset.  |

UL, ULC, CSFM Listed; FM Approved;  
MEA (NYC) Acceptance\*

Addressable Duct Sensor Housings with TrueAlarm  
Photoelectric Sensor; Available with Multiple Relay Control

## Features

**Compact air duct sensor housing with clear cover to monitor for the presence of smoke\*\***

**Includes factory installed TrueAlarm photoelectric smoke sensor and features:**

- Individual sensor information processed by the host control panel to determine sensor status
- Digital transmission of analog sensor values via IDNet or MAPNET II, 2-wire communications
- Programmable sensitivity, consistent accuracy, environmental compensation, status testing, and monitoring of sensor dirt accumulation

### Model 4098-9755:

- Basic duct sensor housing (no relay output) powered by IDNet/MAPNET II communications

### Model 4098-9756:

- Duct sensor housing with supervised output for multiple remote relays; requires separate 24 VDC; includes one relay
- Relay output is under panel control
- At the panel, relay output can be activated manually or in response to a separate alarm or other input

### General features:

- UL listed to Standard 268A
- Clear cover allows visual inspection
- Test ports provide functional smoke testing access with cover in place
- Mounts to rectangular ducts or round ducts; minimum size is 8" (203 mm) square or 18" (457 mm) diameter
- Magnetic test feature for alarm initiation at housing
- Optional weatherproof enclosure is available separately (refer to data sheet S4098-0032)

### Diagnostic LEDs (on interface board):

- Red Alarm/Trouble LED for sensor status and communications polling display
- Yellow LED for open or shorted trouble indication of supervised relay control (4098-9756 only)

### Sampling tubes (ordered separately):

- Available in multiple lengths to match duct size
- Installed and serviced with housing in place

### Remote module options (ordered separately):

- Remote red status/alarm LED (2098-9808)
- Remote test station with LED (2098-9806)
- 4098-9843 remote relays (refer to page 2 for details)

\* These products have been approved by the California State Fire Marshal (CSFM) pursuant to Section 13144.1 of the California Health and Safety Code. See CSFM Listing 3240-0026.241 for allowable values and/or conditions concerning material presented in this document. Accepted for use – City of New York Department of Buildings – MEA35-93E. Additional listings may be applicable; contact your local Simplex product supplier for the latest status. Listings and approvals under Simplex Time Recorder Co. are the property of Tyco Fire Protection Products.

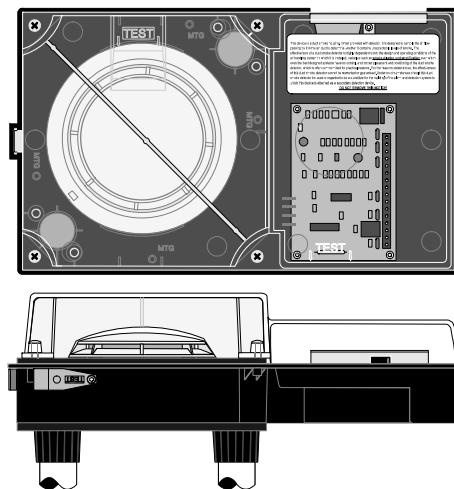

Duct Sensor Housing, Front and Bottom View

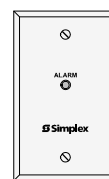

2098-9808

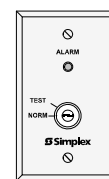

2098-9806

Remote Status/Alarm Indicator and Test Station

## Introduction

**Operation.** Simplex® compact air duct smoke sensor housings provide TrueAlarm operation for the detection of smoke in air conditioning or ventilating ducts. Sampling tubes are installed into the duct allowing air to be directed to the smoke sensor mounted in the housing.

## TrueAlarm Sensor Operation

### Digital Communication of Analog Sensing.

Analog information from the sensor is digitally communicated to the control panel where it is analyzed. Sensor input is stored and tracked as an average value with an alarm or abnormal condition being determined by comparing the sensor's present value against its average.

**Intelligent Data Evaluation.** Monitoring each photoelectric sensor's average value provides a software filtering process that compensates for environmental factors (dust, dirt, etc.) and component aging, providing an accurate reference for evaluating new activity. The result is a significant reduction in the probability of false or nuisance alarms caused by shifts in sensitivity, either up or down.

\*\* Please note that smoke detection in air ducts is intended to provide notification of the presence of smoke *in the duct*. It is not intended to, and will not, replace smoke detection requirements for open areas or other non-duct applications.

## TrueAlarm Sensor Operation (Continued)

**Control Panel Selection.** Peak activity per sensor is stored to assist in evaluating specific locations. The alarm set point for each sensor is determined at the control panel, selectable as the individual application requires.

**Sensor Status LED.** Each sensor housing's red status LED (located on the electrical interface board) pulses to indicate communications with the panel. If the control panel determines that a sensor is in alarm, or that it is dirty or has some other type of trouble, the details are annunciated at the control panel and that sensor housing's status LED will be turned on steadily. During a system alarm, the control panel will control the LEDs such that an LED indicating a trouble will return to pulsing to help identify any alarmed sensors. (Remote Status/Alarm LEDs track the operation of the sensor housing LED.)

## Photoelectric Sensing

TrueAlarm photoelectric sensors use a stable, pulsed infrared LED light source and a silicon photodiode receiver to provide consistent and accurate low power smoke sensing.

## Duct Sensor Selection Chart

### Duct Smoke Sensor Housing with Photoelectric Sensor\*

| Model     | Description   | Compatibility   |
|-----------|---|---|
| 4098-9755 | Basic Duct Sensor Housing; operating power is supplied by either IDNet or MAPNET II communications (no relay output)  | 4007ES, 4008, 4010, 4010ES, 4020, 4100, 4100ES, 4100E, and 4120. Also 2120 CDT if configured for MAPNET II, TrueAlarm operation   |
| 4098-9756 | Duct Sensor Housing with supervised multiple relay output, requires separate 24 VDC fire alarm power and 4081-9008 end-of-line resistor harness; includes one 4098-9843 relay | Same as above except relay operation is not compatible with 2120 CDT;<br>Relay output is for up to 15 total 4098-9843 Relays (additional relays are ordered separately) |

### Remote LED Indicator and Test Station, Select One if Required

| Model     | Description   | Compatibility          | Mounting  |
|-----------|---|------------------------|---|
| 2098-9808 | Red LED status indicator on single-gang stainless steel plate   | 4098-9755<br>4098-9756 | Use single gang box,<br>3" H x 2" W x 2" D<br>(76 mm x 51 mm x 51 mm) |
| 2098-9806 | Test Station with keyswitch and red LED status indicator, on single-gang stainless steel plate; (turning switch to "TEST" initiates alarm for system testing) |                        |   |

### Epoxy Encapsulated Remote Relay and End-of-Line Resistor

| Model     | Description   | Compatibility                       | Location   |
|-----------|---|-------------------------------------|--|
| 4098-9843 | Relay; single Form C (7 A @ 120 VAC); refer to pages 3 and 4 for additional relay information; one included with 4098-9756; wiring is 18 AWG (0.82 mm <sup>2</sup> ) color coded wire leads | 4098-9756 only;<br>connect up to 15 | Locate relays within 3 ft (1 m) of device being controlled per NFPA 72 |
| 4081-9008 | End-of-Line Resistor Harness; 10 kΩ, 1/2 W; (ref. 733-894); required to supervise remote relay coil connection  | 4098-9756                           | At last relay location   |

\* Each duct housing includes an internally mounted model 4098-9714 TrueAlarm photoelectric sensor and an exhaust tube. A correctly sized sampling tube (ordered per application) is required, refer to chart below.

## Sampling Tube Selection Chart, Ordered Separately Per Duct Width, Select One

| Overall Duct Width              | Tube Required | Suggested Cut Length                  |
|---------------------------------|---------------|---------------------------------------|
| 12" (305 mm)                    | 4098-9854     | 1/2" (12.7 mm) longer than duct width |
| 13" to 23" (330 mm to 584 mm)   | 4098-9855     | 1/2" (12.7 mm) longer than duct width |
| 24" to 46" (610 mm to 1168 mm)  | 4098-9856     | 3 in" (76 mm) longer than duct width  |
| 46" to 71" (1168 mm to 1803 mm) | 4098-9857     | 3 in" (76 mm) longer than duct width  |
| 71" to 95" (1803 mm to 2413 mm) | 4098-9858     | 3 in" (76 mm) longer than duct width  |

## Photoelectric Sensing (Continued)

Typically duct sensor applications require less sensitive settings (such as 2.5% per foot obscuration) due to the ducts being a relative dirty environment. However, the standard seven levels of TrueAlarm sensor sensitivity are available for each individual sensor, ranging from 0.2% to 3.7% per foot of smoke obscuration. Sensitivity is selected and monitored at the fire alarm control panel.

## Fire Alarm Control Panel Features

- Individual smoke sensitivity selection
- Sensitivity monitoring that satisfies NFPA 72 sensitivity testing requirements
- Peak value logging allows accurate analysis for sensitivity selection
- Automatic, once per minute individual sensor calibration check verifies sensor integrity
- Automatic environmental compensation
- Smoke sensitivity is displayed in percent per foot
- Ability to display and print detailed sensor information in plain English language
- Relays of model 4098-9756 are under panel control for ON, OFF, or override

# Duct Sensor Housing Detail Reference

**NOTE:** Refer to Installation Instructions 574-776 for additional installation detail and maintenance information.

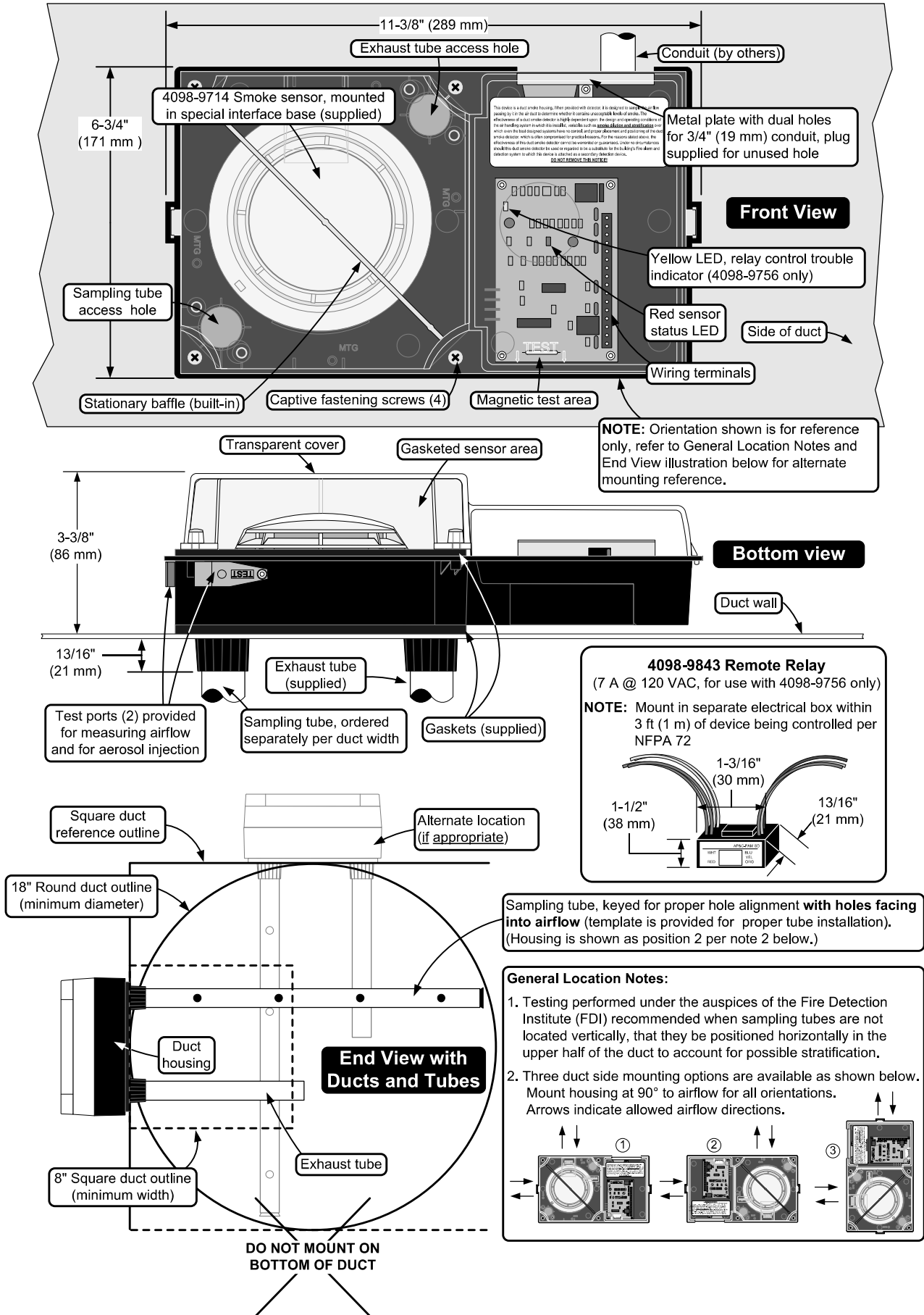

## Duct Sensor Location Reference

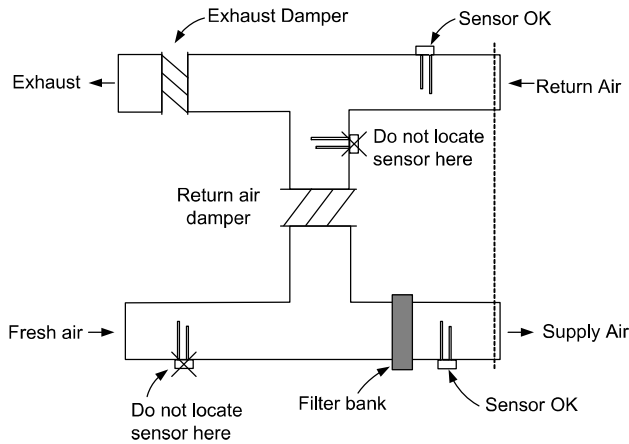

**Additional Information.** Refer to NFPA 90A, *Standard for the Installation of Air Conditioning and Ventilating Systems*; NFPA 72, the *National Fire Alarm and Signaling Code*; and the *NEMA Guide for Proper Use of Smoke Detectors in Duct Applications*, and Installation Instructions 574-776.

## Specifications

### General Mechanical and Environmental

|                                    |   |
|------------------------------------|---|
| Air Velocity Range (linear ft/min) | 300 to 4000 ft/min (91 to 1220 m/min)   |
| Sensor Sensitivity Range           | 0.2% to 3.7% per foot of obscuration, selectable at host control panel        |
| UL Listed Temperature Range        | 32° F to 100° F (0° C to 38° C)   |
| Operating Temperature Range        | 32° F to 122° F (0° C to 50° C)   |
| Storage Temperature Range          | 0° F to 140° F (-18° C to 60° C)  |
| Humidity Range                     | 10% to 95% RH, non-condensing   |
| Wiring Connections                 | Terminal blocks, 18 to 12 AWG (0.82 mm <sup>2</sup> to 3.31 mm <sup>2</sup> ) |
| Housing Color and Material         | Black ABS base with clear polycarbonate cover                                 |
| Sampling and Exhaust Tube Material | Black CPVC, custom extrusion; sampling tubes are pre-drilled                  |

### Remote Status/Alarm LED and Test Station with Remote Status/Alarm LED

|  |  |
|--|--|
| Remote Alarm LED Current                   | 1.2 mA, no impact to 24 VDC alarm current (2098-9808 or 2098-9806) |
| Test Station Keyswitch Current             | 3.3 mA, no impact to 24 VDC alarm current (2098-9806)              |
| Remote Alarm LED and Test Station Distance | 250 ft (76 m) maximum  |

### Addressable Operation

|                     |  |
|---------------------|--|
| Data Communications | IDNet or MAPNET II communications, auto-select, one address per housing; provides operating power to model 4098-9755 |
|---------------------|--|

### Model 4098-9756 with Supervised Multiple Relay Control, Requires Separate Fused 24 VDC from Fire Alarm Power Supply

|  |   |
|--|---|
| Input Voltage                          | 18-32 VDC (24 VDC nominal)  |
| Standby Current                        | 3 mA @ 24 VDC   |
| Alarm Current                          | 15 mA @ 24 VDC; add 15 mA for each 4098-9843 relay  |
| Supervised Remote Relay Control Output | For use with 4098-9843 relay only, quantity of 15 maximum; distance of 500 ft (152 m) maximum; requires 4081-9008 (ref. 733-894) 10 k $\Omega$ , 1/2 W end-of-line resistor |

### 4098-9843 Relay Output Ratings, Single Form C, use with Model 4098-9756 Only

|                   |   |
|-------------------|---|
| Coil Current      | 15 mA @ 24 VDC, up to 15 maximum per relay control output   |
| Relay Contacts    | 7 A at 0.35 PF @ 28 VDC & 120 VAC; 250 $\mu$ A @ 5 VDC  |
| Location Distance | 500 ft (152 m) maximum to relay coils; locate relays within 3 ft (1 m) of device being controlled per NFPA 72 |

TYCO, SIMPLEX, and the product names listed in this material are marks and/or registered marks. Unauthorized use is strictly prohibited. NFPA 72 and National Fire Alarm and Signaling Code are registered trademarks of the National Fire Protection Association (NFPA).

## Duct Sensor Location Considerations:

1. Proper duct smoke detection location must ensure adequate airflow within the duct housing.
2. Duct air velocity rating is 300 to 4000 ft/min (91 to 1220 m/min). Pressure differential between intake and exhaust tubes is required to be between 0.015 to 1.55 inches of water (0.381 to 39.37 mm).
3. Ensure accessibility for test and service.
4. Proper Locations: downstream side of filters to detect fires in the filters; in return ducts, ahead of mixing areas; upstream of air humidifier and cooling coil.
5. Other locations and orientations may be required for proper duct smoke detection depending on duct access, system design, and duct airflow testing. Contact your local Simplex product supplier for assistance.

## Locations to Avoid:

1. Where dampers closed for comfort control would interfere with airflow.
2. Next to outside air inlets (unless the intent is to monitor smoke entry from that area).
3. In return air damper branch ducts and mixing areas where airflow may be restricted.

### Features

#### Individual Addressable Relay Module (Relay IAM):

- IDNet addressable control for use with Simplex® fire alarm control panel models 4007ES, 4008, 4010, 4010ES, 4100ES, and 4100U
- A single addressable point provides control and status tracking of a Form “C” contact
- Low power latching relay design allows IDNet communications to supply both data and module power
- Relay is set to OFF on initial power up and upon loss of IDNet communications

#### Compact, sealed construction:

- Enclosed design minimizes dust infiltration
- Mounts in standard 4” (102 mm) square electrical box, optional adapter bracket is available to mount in a 4 11/16” (119 mm) square electrical box
- Screw terminals for wiring connections
- Visible LED flashes to indicate communications
- Optional covers are available to allow LED to be viewed after installation

#### UL listed to Standard 864

### Description

**IDNet Relay IAMs** allow fire alarm control panels to control a remotely located Form “C” contact using IDNet addressable communications for both data and module power. Typical applications would be for switching local power for control functions such as elevator capture, or control of HVAC components, pressurization fans, dampers, etc. Relay status is also communicated requiring only one device address.

### Product Selection

| Model     | Description |
|-----------|-------------|
| 4090-9002 | Relay IAM   |

#### Optional Adapter and Trim Plates

| Model     | Description  |   |
|-----------|--|---|
| 4090-9813 | Adapter plate to fit 4 11/16” (119 mm) square electrical box |   |
| 4090-9801 | For semi-flush mounted box                                   | Trim Plate, galvanized steel, with LED viewing window; includes mounting screws |
| 4090-9802 | For surface mounted box                                      |   |

\* This product has been approved by the California State Fire Marshal (CSFM) pursuant to Section 13144.1 of the California Health and Safety Code. See CSFM Listing 7300-0026:223 for allowable values and/or conditions concerning material presented in this document. Accepted for use – City of New York Department of Buildings – MEA35-93E. Additional listings may be applicable; contact your local Simplex product supplier for the latest status. Listings and approvals under Simplex Time Recorder Co. are the property of Tyco Fire Protection Products.

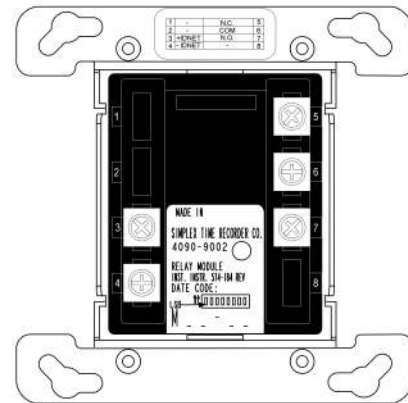

4090-9002 IDNet Relay IAM Package  
(shown approximately 1/2 size)

### Specifications

|  |  |                               |
|--|--|-------------------------------|
| Communications   | IDNet communications, 1 address per device   |                               |
| Relay IAM Power  | Supplied by IDNet communications   |                               |
| <b>Contact Ratings*</b> (not rated for incandescent switching)   |  |                               |
| Type   | Form C, SPDT   |                               |
| Power-Limited  | 2 A @ 24 VDC, resistive  | from listed fire alarm supply |
|  | 1 A @ 24 VDC, inductive  |                               |
| Nonpower-Limited   | 0.5 A @ 120 VAC, resistive   |                               |
| * Provide circuit fusing and transient suppression as required per application. DC inductive loads can typically be diode suppressed; 120 VAC loads may require RC networks or varistors, depending on device type. Refer to the installation instructions for additional information. |  |                               |
| Wire Connections   | Screw terminals for in/out wiring, 18 to 14 AWG wire (0.82 to 2.08 mm <sup>2</sup> ) |                               |
| IDNet Communications Wiring Reference  | Up to 2500 ft (762 m) from control panel   |                               |
|  | Up to 10,000 ft (3048 m) total wiring distance (including T-Taps)                    |                               |
|  | Compatible with Simplex 2081-9044 Overvoltage Protectors                             |                               |
| Dimensions   | 4 1/8" H x 4 1/8" W x 1 3/8" D (105 mm x 105 mm x 35 mm)                             |                               |
| Housing Material   | Black thermoplastic  |                               |
| Mounting Plate   | Sheet metal, galvanized  |                               |
| Temperature Range  | 32° to 120° F (0° to 49° C), intended for indoor operation                           |                               |
| Humidity Range   | Up to 93% RH at 100° F (38° C)   |                               |
| Installation Instructions  | 574-184  |                               |

## Relay IAM Mounting Information

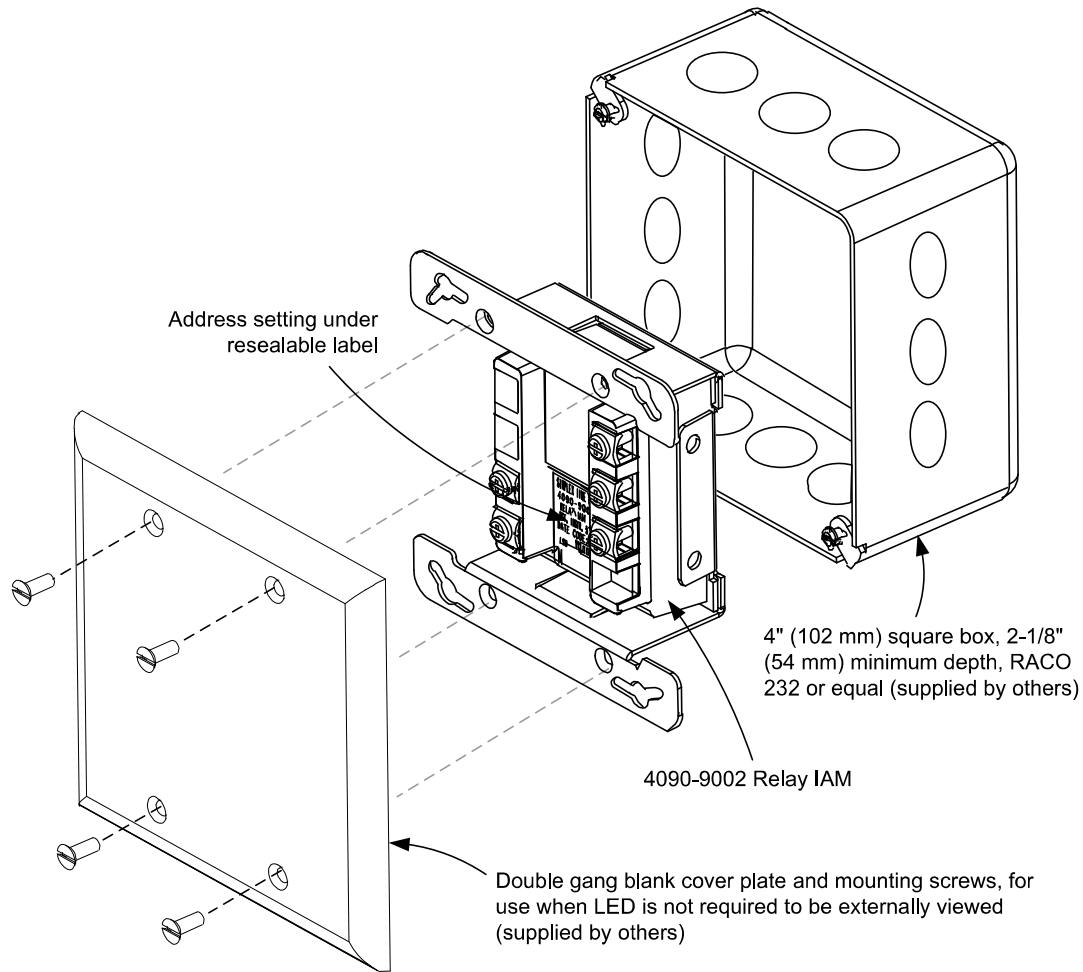

### Mounting Reference, Double Gang Blank Cover Plate

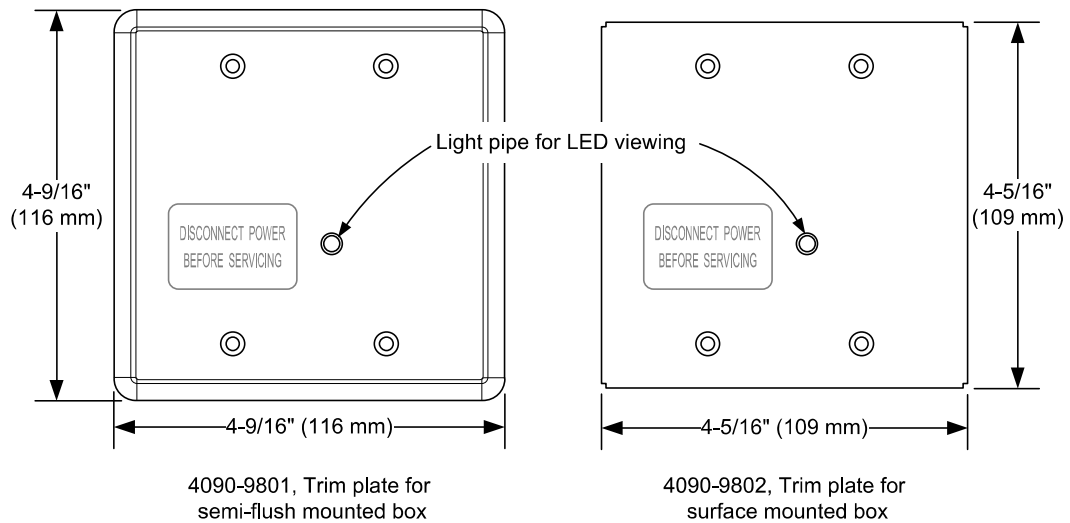

### Optional Trim Plates for Visible LED

TYCO, SIMPLEX, and the product names listed in this material are marks and/or registered marks. Unauthorized use is strictly prohibited.



Tyco Fire Protection Products • Westminister, MA • 01441-0001 • USA

S4090-0002-10 11/2014

[www.simplex-fire.com](http://www.simplex-fire.com)

© 2014 Tyco Fire Protection Products. All rights reserved. All specifications and other information shown were current as of document revision date and are subject to change without notice.

#### Features

**Provides additional notification appliance circuit (NAC) capacity with flexible operation modes and power-limited design**

**Four, Class B NACs are standard:**

- Rated 2 A each for conventional reverse polarity 24 VDC notification appliances and providing multiple operation modes.
- Can be selected to provide synchronization for Simplex visible notification strobe flashes.
- Capable of controlling TrueAlert non-addressable notification appliances operating with SmartSync two-wire control mode.

**Input control options:**

- IDNet addressable communications from a 4007ES, 4010, 4010ES, 4100U, or 4100ES Fire Alarm Control Panel. See note.
- Or from one or two conventional 24 VDC NACs with multiple output control options

**IDNet communications control benefits:**

- Provides status monitoring and individual NAC control using a single address per 4009 IDNet NAC Extender
- Supports IDNet "Device Level" earth fault location

**WALKTEST operation is available with either input choice**

**Internal 8 A power supply/battery charger:**

- Charges internal batteries up to 12.7 Ah or up to 18 Ah batteries in external cabinet
- Provides status monitoring of battery, input power, and earth faults
- Rated 8 A for "Special Application" appliances; including 4901, 4903, 4904, and 4906 Series horns, strobes, horn/strobes, and speaker/strobes
- Rated 6 A for "Regulated 24 DC" appliance power

**Optional 4009 IDNet NAC Extender modules:**

- IDNet Communications Repeater provides Class B or Class A output
- IDNet Communications Fiber Optic Receiver/Repeater, available as Class B or Class X
- Four additional Class B NACs, rated 1.5 A for Special Application appliances; 1 A for Regulated 24 DC appliance power
- Class A, Two Circuit Adapter Module

**UL Listed to Standard 864**

#### External Accessories

**IDNet communication fiber optic transmitters:**

- For applications requiring the data integrity available with fiber optic communications
- Available as Class B or Class X
- Mounts in standard six-gang electrical box

**External battery cabinet for 18 Ah batteries**

#### Introduction

**ADA compliance.** Complying with the notification requirements of ADA (Americans with Disabilities Act) may require more notification appliance power than is available within the fire alarm control panel. When additional power is required, a 4009 IDNet NAC Extender can provide up to 8 A of NAC power with up to eight, supervised reverse polarity NACs.

**Location flexibility.** The 4009 IDNet NAC Extender can be mounted close to a compatible dedicated host panel or can be located remotely for convenient power distribution. Multiple operation modes and multiple connection options further increase location flexibility.

**Additional information.** For additional operation detail and application information, refer to *Installation Instructions 574-181* and *field wiring diagram 842-068*.

**Note:** 4100U requires revision 11 software or higher for compatibility. 4010 requires revision 2 software or higher for compatibility.

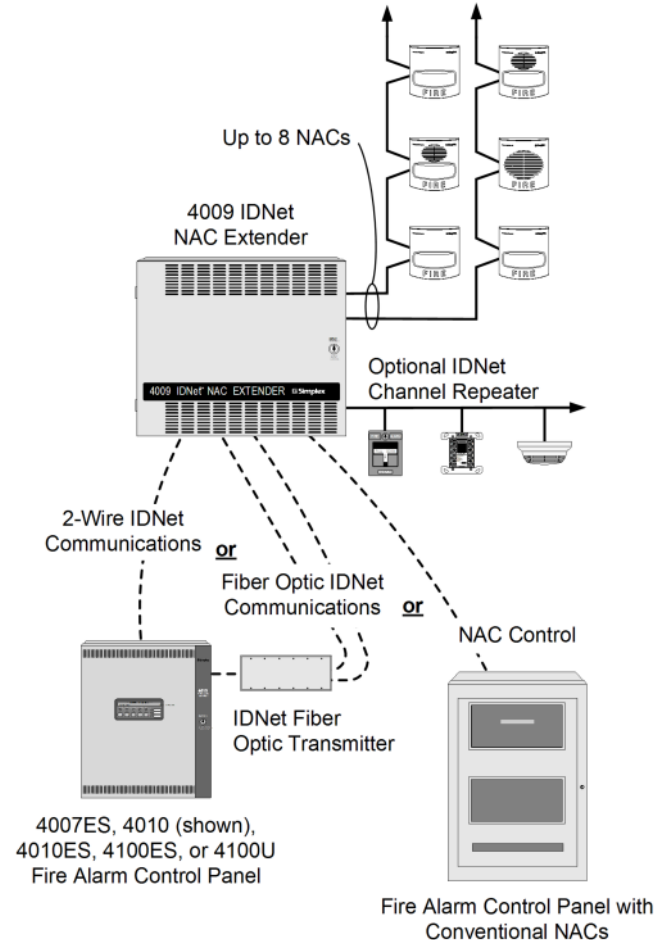

Figure 1: 4009 IDNet NAC Extender connection reference drawing



## Application and operation information

**IDNet addressable communications compatible.** Up to 10, 4009 IDNet NAC Extenders can be controlled for each 4007ES, 4010ES, 4100U, or 4100ES IDNet communications channel; up to 5 can be controlled on the 4010 IDNet communications channel. Each output NAC can be individually controlled for general alarm or selective area notification requiring only one point address for each Extender. Individual Extender NACs can also be manually controlled from the host panel. IDNet controlled extenders will inform the host panel of troubles using IDNet communications. 4007ES, 4010ES, 4100ES, and 4100U control panels control using multi-point rules, refer to data sheet [S4090-0011](#) for details.

**Optional IDNet repeaters.** IDNet communications can be repeated with the optional IDNet Repeater Module or with the optional Fiber Optic Receiver Module. Up to 100 of the IDNet channel points can be repeated once (refer to [Typical IDNet connection example](#) and [4009 IDNet NAC Extender specifications](#) for details). Repeated IDNet communications also support the "device level" earth fault location utility of the host panel.

**Hardware control applications.** For applications where an existing (or new) conventional NAC needs additional power, the 4009 IDNet NAC Extender can be controlled directly from the NAC. Either one or two NACs, from either the same, or from different host fire alarm control panels, can be connected to control the 4009 IDNet NAC Extender output NACs. Multiple control selections provide flexible operation. (See [Hardware Control Connection Information](#) for more detail.) Alarms from the host panel will activate the four, 4009 IDNet NAC Extender NACs (or optionally, 8 NACs) to extend the alarm.

The 4009 IDNet Extender monitors itself and each of its output NACs for trouble conditions, including earth faults. Extenders wired to conventional NACs will indicate a trouble by opening the path to the NAC's end-of-line resistor, but retaining the ability to respond to alarms. Individual troubles are also annunciated by LEDs located on the 4009 IDNet NAC Extender main circuit board. Refer to [Service diagnostic features](#) for more diagnostic information.

## Product selection

**Table 1: Standard models**

| Model  | Description   | Comments  |
|--|---------------|---|
| 4009-9201**  | 120 VAC input | 4009 IDNet NAC Extender with 4, Class B NACs and 8 A power supply |
| 4009-9301  | 240 VAC input |   |
| 4009-9202CA (ULC listed model)   | 120 VAC input |   |
| ** 4009-9201 has been seismic tested and is certified to IBC and CBC standards as well as to ASCE 7 categories A through F, requires battery brackets as detailed on data sheet <a href="#">S2081-0019</a> |               |   |

**Table 2: Optional modules (for on-site installation)**

| Model   | Description  | Comments   |
|---|--|--|
| 4009-9807   | Additional four point NAC module, rated 1.5 A Special Application appliances; 1 A for Regulated 24 DC appliance power, Class B | 1 maximum  |
| 4009-9808   | Dual Class A adapter (for two NAC outputs)   | Select as required (4 maximum)   |
| 4009-9809   | IDNet Repeater, output is Class A or Class B   | Select <b>either</b> an IDNet Repeater <b>or</b> a Fiber Optic Receiver as required; one transmitter can connect to one receiver |
| 4009-9810   | Fiber Optic Receiver   | Class B  |
| 4009-9811   | Fiber Optic Receiver   | Class A (IDNet), Class X (fiber)   |
| 4009-9805   | Red Appliqué for door  | Select if required   |
| 2975-9801   | Semi-Flush Trim Kit  | Beige trim   |
| 2975-9802   | Semi-Flush Trim Kit  | Red trim   |
| 1 7/16 in. wide (78 mm), use if required for semi-flush installations |  |  |

**Table 3: Battery selection (select battery size using system requirements)**

| Model     | Description             | Comments  |
|-----------|-------------------------|---|
| 2081-9272 | 6.2 Ah Battery, 12 VDC  | Two batteries are required, 24 VDC operation                                    |
| 2081-9274 | 10 Ah Battery, 12 VDC   |   |
| 2081-9288 | 12.7 Ah Battery, 12 VDC |   |
| 2081-9275 | 18 Ah Battery, 12 VDC   | Requires external battery cabinet, two batteries are required, 24 VDC operation |

**Table 4: External accessories (select using system requirements)**

| Model  | Description   | Comments   |
|--|---|--|
| 4090-9105  | IDNet Fiber Optic Transmitter   | Class B operation  |
| 4090-9107  |   | Class X operation  |
| Mounts in six-gang electrical box, refer to <a href="#">4090-9105/9107 IDNet fiber optic transmitter mounting information</a> for mounting details |   |  |
| <b>Note:</b> Class B Fiber Transmitter Rev C or higher, IS NOT COMPATIBLE with Class B Fiber Receiver before Rev J.                                |   |  |
| 4009-9801  | External battery cabinet for up to 18 Ah batteries, beige                             | 16-1/4 in. W x 13-1/2 in. H x 5-3/4 in. D (413 mm x 343 mm x 146 mm) |
| 4081 series  | End-of-Line resistor harnesses; see data sheet <a href="#">S4081-0003</a> for details |  |

Typical IDNet connection example

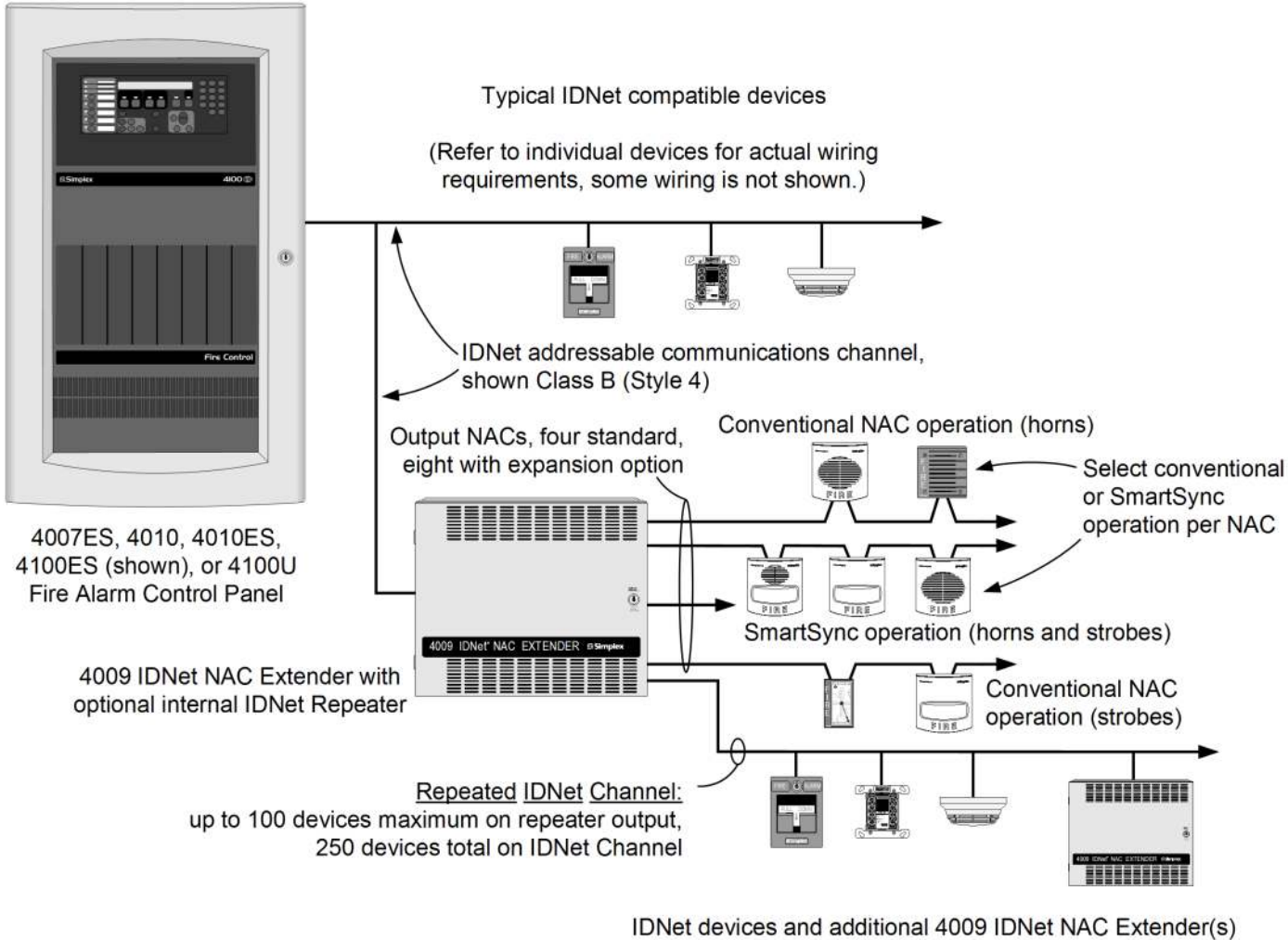
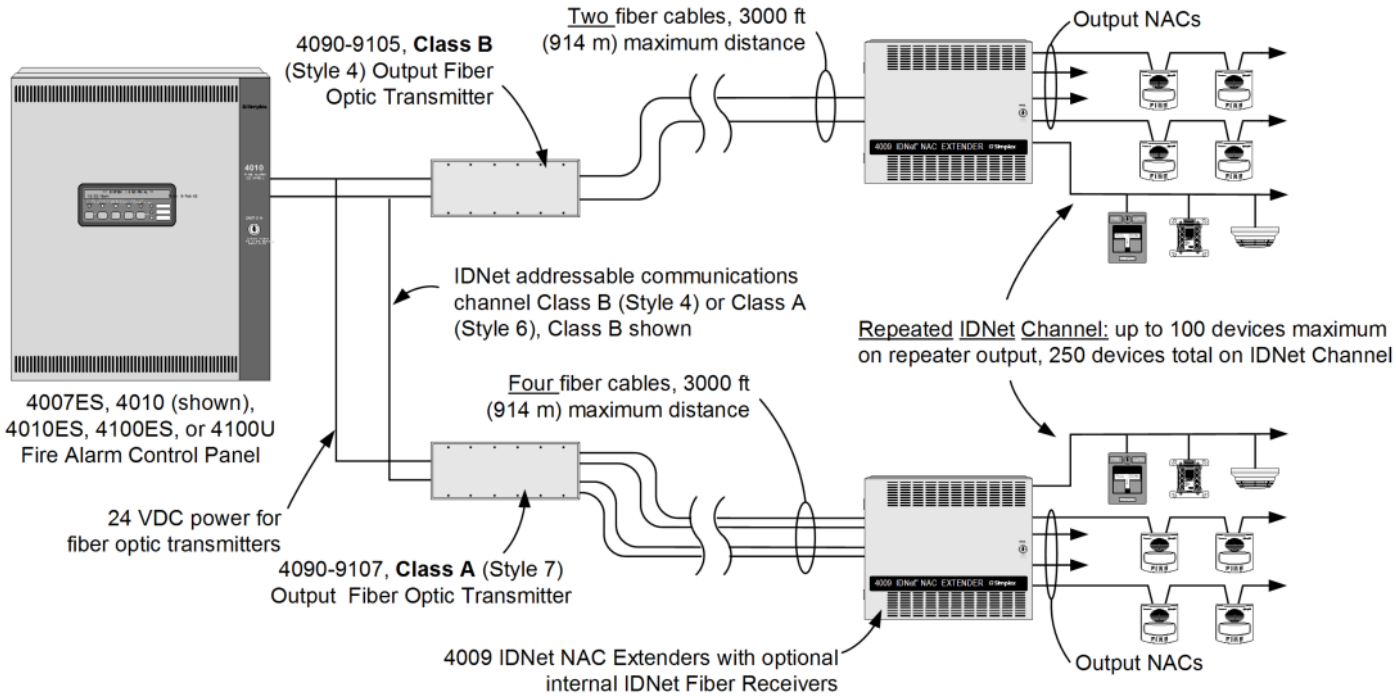

Figure 2: Typical IDNet connection example

**Note:** Up to 10 4009 IDNet NAC Extenders may be connected using 4007ES, 4010ES, 4100U, or 4100ES IDNet channel, up to 5 on the 4010 IDNet channel. IDNet communications can be repeated only once (can pass through only one series connected repeater or one fiber optic receiver).

**Typical fiber optic system connections**



**Figure 3: Typical fiber optic system connections**

**Note:** Up to 10 4009 IDNet NAC Extenders may be connected per 4007ES, 4100ES, or 4010ES. Up to 5 4009 IDNet NAC Extenders may be connected on the 4010 IDNet channel. IDNet communications can be repeated only once (can pass through only one series connected repeater or one fiber optic receiver). Fiber optic transmitters connect to only one receiver in a 4009 IDNet NAC Extender.

**Hardwire Control Connection Information**

**NAC Input Selections.** The 4009 IDNet NAC Extender can be selected to:

- Track input NAC operation **or** to provide a locally generated code, selectable using NAC input.
- If selected for local coding, NAC outputs can be either **Temporal Coded** or **60 Beats/min March Time Coded**, one code selection per extender (input NACs must be on continuous with Alarm).
- Additionally, NAC outputs can be selected to provide the Simplex strobe synchronization signal. This signal will synchronize the flashes of synchronized strobes but will be ignored by free-run strobes and audible devices. (Strobes are for operation by noncoded NACs.)

**NAC input to NAC output control** can be selected for standard and optional NACs per the following table:

**Table 5: Conventional NAC Output Operation Options**

| Input | A                     | B          | C          |
|-------|-----------------------|------------|------------|
| NAC 1 | NACs 1 and 2, 5 and 6 | NACs 1 - 4 | NACs 1 - 8 |
| NAC 2 | NACs 3 and 4, 7 and 8 | NACs 5 - 8 | -          |

**Table 6: SmartSync NAC Output Operation**

| Input | NAC Control Function |                         |
|-------|----------------------|-------------------------|
| NAC 1 | Strobe Control       | All NAC outputs (1 - 8) |
| NAC 2 | Horn Control         |                         |

### SmartSync Notification Appliance Control

The **TrueAlert Notification Appliance** product line includes addressable and non-addressable operation. Non-addressable models are available with 2-wire SmartSync operation or conventional 4-wire operation. The following details apply to use with the 4009 IDNet NAC Extender:

- TrueAlert non-addressable models with SmartSync operation allow audible notification to be separately controlled over the same wire pair that controls visible notification.
- 4009 IDNet NAC Extenders can be selected to provide SmartSync operation whether controlled by IDNet communications or conventional NACs.
- IDNet control allows output NACs to be **individually selected** for conventional **or** SmartSync operation.
- With NAC input control, **all** output NACs are selected for either conventional **or** SmartSync operation.
- Refer to data sheet *S4009-0003* for TrueAlert Addressable operation details, contact your local Simplex product supplier for further information on specific TrueAlert notification appliances.

### Hardwire control NAC connection one-line reference diagram

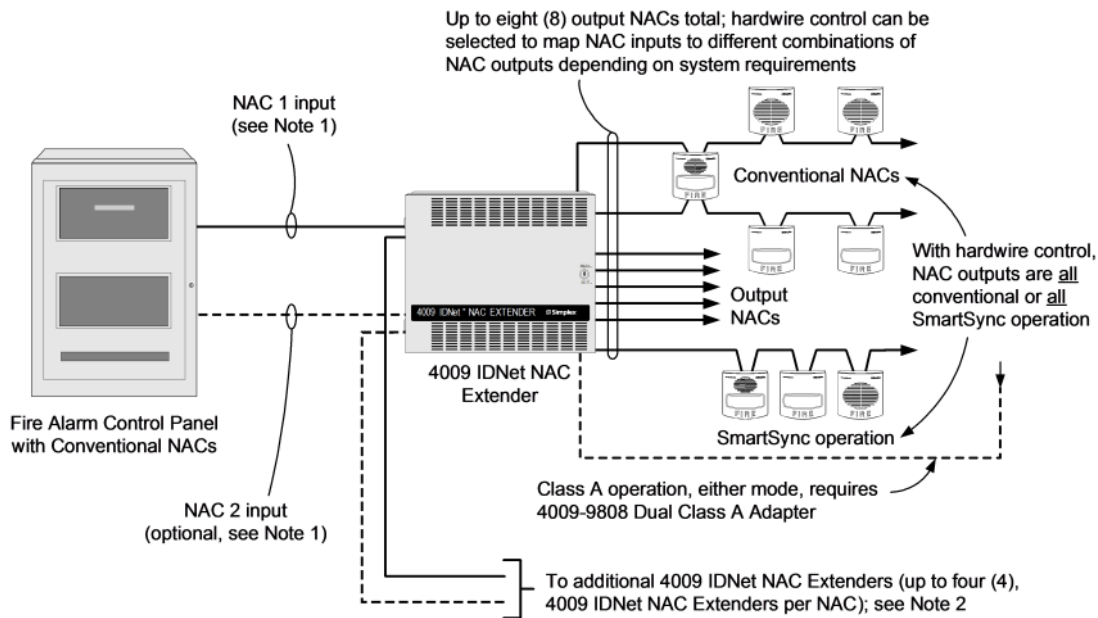

Figure 4: Hardwire control NAC connection one-line reference diagram

**Note:**

1. For separate audible and visible output NAC control, or SmartSync NAC output operation, 2 input NACs are required. NAC 1 is "on-until-reset" and NAC 2 is "on-until-silenced".
2. To synchronize strobe flash outputs for up to 4 4009 IDNet NAC Extenders, use the synchronized strobe output from a Synchronized Flash Module (4905-9914 for Class B operation, 4905-9922 for Class A operation) or, if available, from a NAC selected to provide synchronized strobe flash output. **NOTE: DO NOT USE a NAC selected for SmartSync operation for this function.**

Refer to Installation Instructions *574-181* for additional information and application guidance.

## 4009 IDNet NAC Extender specifications

**Table 7: Input ratings**

| Specification   | Rating                                  |
|---|---|
| 120 VAC input (4009-9201)                               | 3A @ 102 VAC -132 VAC, 60 Hz            |
| 240 VAC input (4009-9301)                               | 1.5A @ 204 VAC -264 VAC, 50 Hz /60 Hz   |
| Hardwire control from external NACs; input requirements | Conventional reverse polarity operation |
|   | 5 mA maximum; 16 VDC to 33 VDC          |

**Table 8: Output ratings**

| Specification                       | Rating   |
|-------------------------------------|--|
| Total rating                        | 8 A, Special application appliances 6 A, regulated 24 DC appliance power   |
| Standard NACs                       | 2 A each, special application or regulated 24 DC appliance power   |
| Optional NACs (requires 4009-9807 ) | 1.5 A each, Special Application appliances 1 A each, Regulated 24 DC appliance power   |
| Special application appliances      | Simplex non-addressable horns, strobes, and combination horn/strobes and speaker/strobes (contact your Simplex product representative for compatible appliances) |
| Regulated 24 DC appliances          | Power for other UL listed appliances; use associated external synchronization modules where required   |
| Strobe operation                    | Up to 33 strobes for each NAC can be synchronized; output NACs configured for Simplex synchronized strobe operation are synchronized to each other               |
| Auxiliary output                    | 500 mA @ 24 VDC nominal  |

**Table 9: Optional modules ratings**

| Specification                                 | Rating   |  |
|---|--|--|
| <b>IDNet Repeater Module</b><br>( 4009-9809 ) | Input power  | 70 mA @ 24 VDC, system supplied  |
|   | IDNet input, one address                                       | Maximum distance from IDNet source is 2,500 ft (762 m)   |
|   | IDNet output specifications                                    | Repeated IDNet output for up to 100 devices (total IDNet devices not to exceed 250 for each channel) |
|   |  | Maximum distance to farthest device is 2,500 ft (762 m)  |
|   |  | Total distance including "T-taps" is 10,000 ft (3048 m)  |
|   | Class A loop maximum distance is 2,500 ft (762 m), no "T" taps |  |

**Table 10: Fiber optic receiver modules**

| Specification                     | Rating   |
|-----------------------------------|--|
| Input current                     | 4009-9810 , Class B, 65 mA @ 24 VDC, system supplied |
|                                   | 4009-9811 , Class X, 80 mA @ 24 VDC, system supplied |
| IDNet output specifications       | Same as those for repeater module                    |
| Fiber optic transmission distance | 3000 ft (914 m) maximum                              |

**Table 11: General specifications**

| Specification   | Rating  |
|---|---|
| Operating temperature   | 32° F to 120° F (0° C to 49° C)                         |
| Operating humidity range  | 10% to 90% RH from 32° F to 104° F (0° C to 40° C)      |
| Wiring Connections*   | Terminal blocks for 18 AWG (stranded) to 12 AWG (solid) |
| <b>Note:</b> * Metric wire equivalents: 18 AWG = 0.82 mm <sup>2</sup> ; 12 AWG = 3.31 mm <sup>2</sup> |   |

## Fiber optic transmitter specifications

**Table 12: Fiber optic transmitter specifications**

| Specification  | Rating  |
|--|---|
| Input voltage  | 18.9 VDC -32 VDC from compatible listed fire alarm supply   |
| Input current  | 4090-9105, Class B, 30 mA @ 24 VDC  |
|  | 4090-9107, Class X, 35 mA @ 24 VDC  |
| Fiber optic connections and cable requirements   | Multimode, graded index, 50/125µm, 62.5/125 µm, 100/40 µm, or 200 µm  |
|  | Type ST connectors  |
|  | 4090-9105, Class B operation, two fiber cables required<br>4090-9107, Class X operation, four fiber cables required |
| Module size (with mounting bracket)  | 6-13/16 in. W x 3-3/4 in. H x 1-1/8 in. D (173 mm x 95 mm x 29 mm)  |
| On-board status indicators   | Green LED flashing = transmit   |
|  | Red LED flashing = receive  |
|  | Separate red LED on 4090-9107 = Class X receive   |
| Communications   | Simplex IDNet   |
| Fiber optic transmission distance  | 3000 ft (914 m) maximum   |
| Wiring connections*  | Terminal blocks for 18 AWG (stranded) to 12 AWG (solid)   |
| Operating humidity   | 10% to 90% RH from 32° F to 104° F (0° C to 40° C)  |
| Operating temperature  | 32° F to 120° F (0° C to 49° C)   |
| * Metric wire equivalents: 18 AWG = 0.82 mm <sup>2</sup> ; 12 AWG = 3.31 mm <sup>2</sup> |   |

4009 IDNet NAC Extender mounting and module placement information

Additional four point module shown model 4009-9807 .

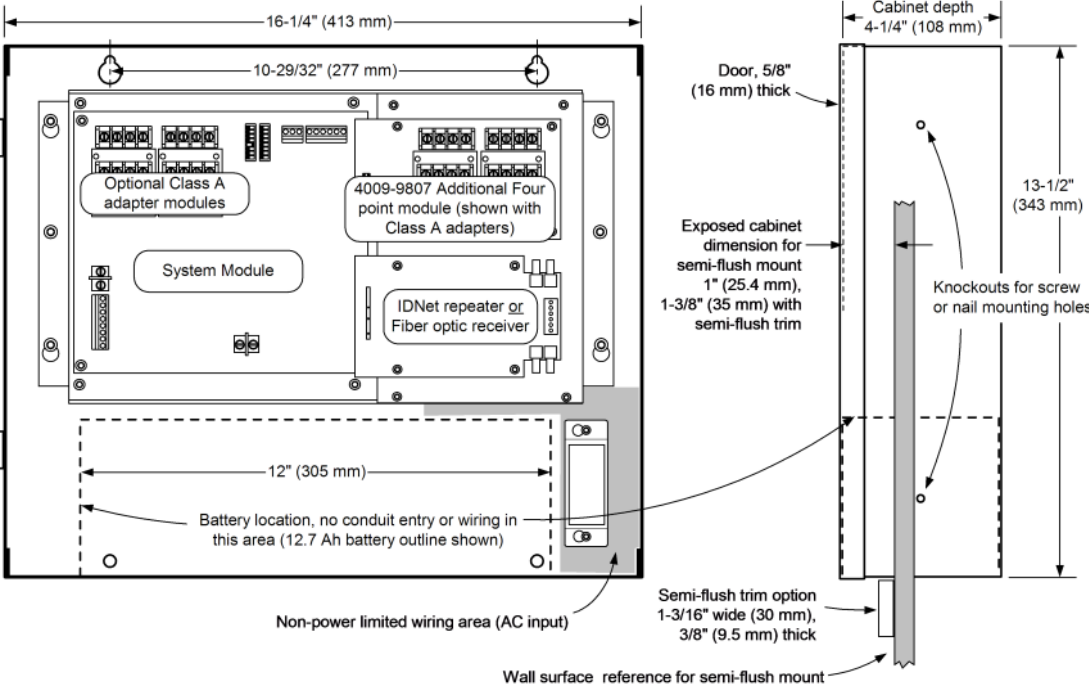

Figure 5: 4009 IDNet NAC Extender mounting and module placement information

**Note:** Recommended conduit entrance varies with module selection. Refer to general installation instructions 574-181, specific module installation instructions, and to field wiring diagrams 842-068 before locating conduit entrance.

4009 IDNet NAC extender cabinet with door detail

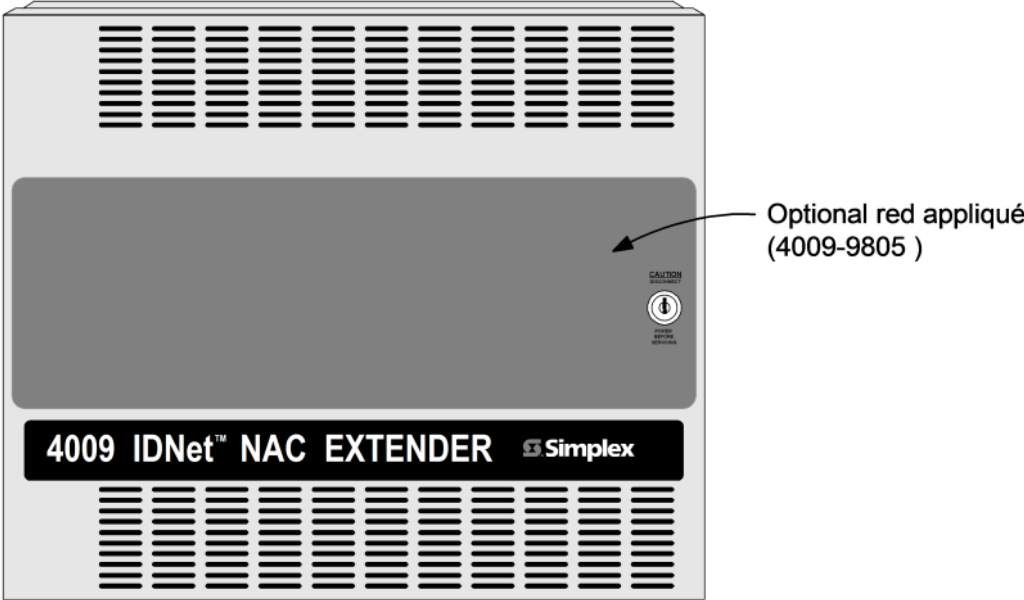
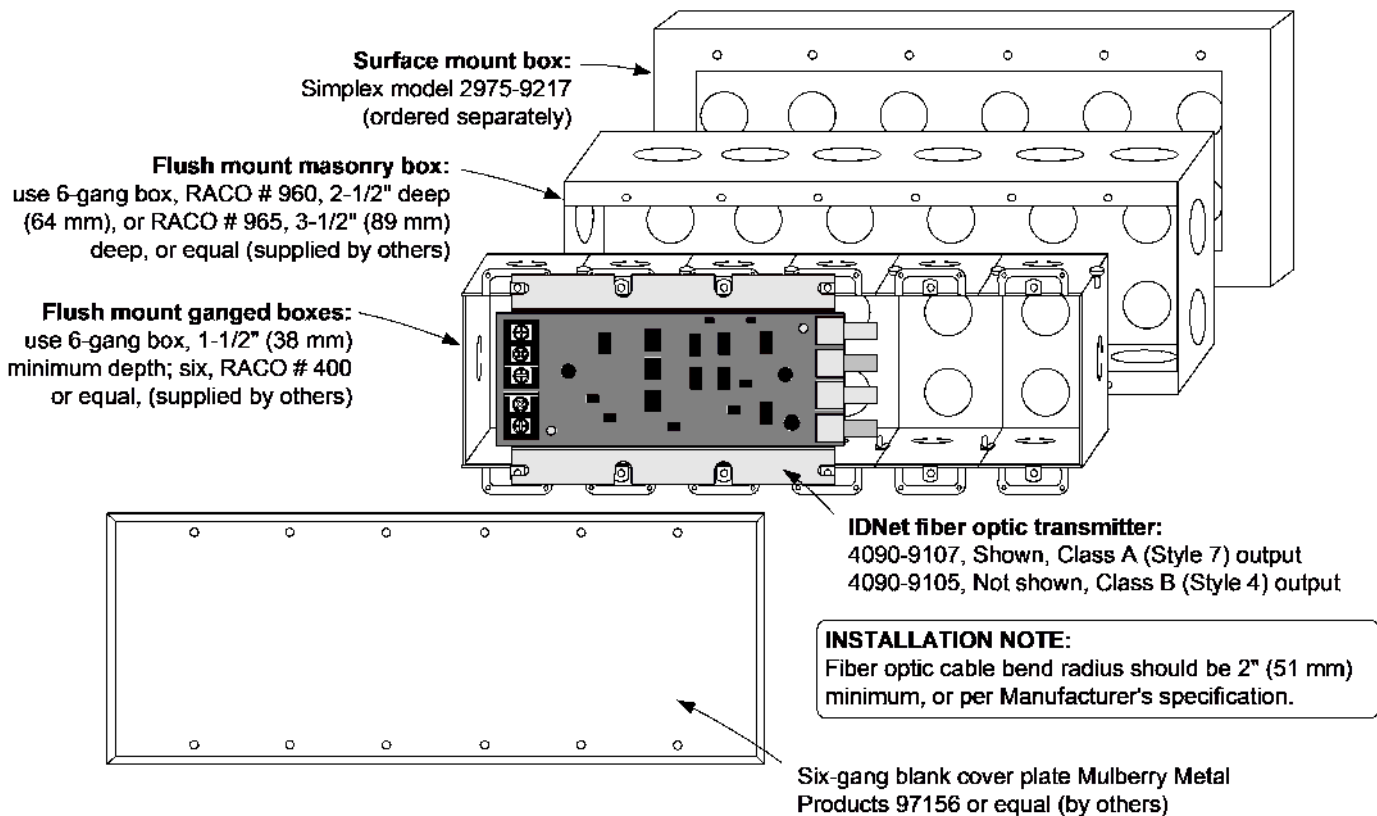

Figure 6: 4009 IDNet NAC extender cabinet with door detail

4090-9105/9107 IDNet fiber optic transmitter mounting information



Service diagnostic features

**Power-up self-diagnostics.** Upon power-up, the 4009 IDNet NAC Extender tests each module and performs earth fault diagnostics. Trouble conditions are communicated to the host control panel and are also displayed on diagnostic status LEDs in the 4009 IDNet NAC Extender. When connected via IDNet communications, detailed status information is available at the host. When controlled with conventional NAC inputs, common troubles are signaled by providing a polarized open circuit that disconnects the NAC wiring from its end-of-line resistor but still allows a reversed polarity alarm to be received.

**Door mounted reference label.** The 4009 IDNet NAC Extender has a detailed programming and diagnostic label inside the front door that provides a quick reference for both installation and checkout.

**LED Status Indicators** are provided for the following:

- **Each NAC** (standard and optional) has a dedicated yellow LED that:
  - During supervision provides a slow flash to indicate a short circuit condition and a fast flash to indicate an open circuit.
  - During an alarm, the LED follows the NAC output (on steady or flashing with coded output).
- **Four, general status yellow LEDs** provide nine separate indications listed in priority of urgency. As a trouble is eliminated, any remaining trouble will then be indicated until the 4009 IDNet NAC Extender is returned to normal operation.
- **AC power status** is indicated by a green LED that is on when AC is normal. During low AC (brownout) conditions or with no AC, the LED is off. Additional power and battery status is indicated by the general status LEDs.



**4009 IDNet NAC extender current calculation chart**
**Step 1. Calculate the basic extender battery requirements (minus NAC loads)**
**Panel, NAC Options, and Auxiliary Power** (underlined model numbers are optional modules).

| Model                           | Description                                  | Supervisory current | Actual supervisory | Alarm current    | Actual alarm |
|---------------------------------|--|---------------------|--------------------|------------------|--------------|
| 4009-9201                       | 120 VAC input                                | Basic Panel         | 85 mA              | 185 mA           | 185 mA       |
| 4009-9301                       | 240 VAC input                                |                     |                    |                  |              |
| 4009-9807                       | Additional four point NAC                    | 40 mA               | + _____            | 40 mA            | + _____      |
| 4009-9808                       | Dual class A adapter (no additional current) | -                   | -                  | -                | -            |
| Auxiliary power output          |  | (500 mA maximum)    | + _____            | (500 mA maximum) | + [A1] _____ |
| Basic panel supervisory current |  |                     | = [S1] _____       |                  |              |
| Basic panel alarm current       |  |                     |                    |                  | = [A2] _____ |

**Step 2. Calculate IDNet output module and device current (if used)**

|   |                               |                                  |                                 |             |                             |              |
|---|-------------------------------|----------------------------------|---------------------------------|-------------|-----------------------------|--------------|
| 4009-9809   | IDNet Repeater                | Select one for each extender     | 70 mA                           | + _____     | 70 mA                       | + _____      |
| 4009-9810 *   | Fiber Optic Receiver, Class B |                                  | 65 mA                           |             | 65 mA                       |              |
| 4009-9811 *   | Fiber Optic Receiver, Class X |                                  | 80 mA                           |             | 80 mA                       |              |
| IDNet devices (connected to repeater or receiver above), 0.7 mA each, maximum of 100                  |                               |                                  | Total devices x 0.7 mA each     | + _____     | Total devices x 0.7 mA each | + _____      |
| <b>Note:</b> IDNet Fiber Optic Transmitter current is supplied from the host fire alarm control panel |                               | IDNet module supervisory current |                                 | [S2] = ____ |                             |              |
|   |                               | IDNet module alarm current       |                                 |             |                             | = [A3] _____ |
|   |                               |                                  | Maximum available current       |             |                             | = 8 A*       |
| <u>Step 2. Calculate available NAC current</u>  |                               |                                  | Subtract auxiliary power output |             |                             | - [A1] _____ |
|   |                               |                                  | Subtract IDNet module current   |             |                             | - [A3] _____ |
| * 8 A for special application appliances; 6 A for regulated 24 DC appliances                          |                               |                                  | Available NAC current           |             |                             | = [A4] _____ |

**Step 3. Calculate actual NAC loading** (Limited to available NAC current per Step 2.)

| NAC type  | NAC circuit # | NAC alarm current |
|---|---------------|-------------------|
| <b>Standard panel NACS</b> , 2 A maximum for each NAC   | Circuit 1     | + _____           |
|   | Circuit 2     | + _____           |
|   | Circuit 3     | + _____           |
|   | Circuit 4     | + _____           |
| <b>Optional four point NAC module</b> , 1.5 A maximum special application rating, 1 A maximum regulated 24 DC rating, per NAC | Circuit 5     | + _____           |
|   | Circuit 6     | + _____           |
|   | Circuit 7     | + _____           |
|   | Circuit 8     | + _____           |
| Total actual NAC load alarm current   |               | = [A5] _____      |

**Step 4. Calculate total supervisory current**
**Total supervisory current** = Basic panel current [S1] + IDNet Module current [S2] = \_\_\_\_\_

**Step 5. Calculate total alarm current**
**Total alarm current** = Basic panel current [A2] + IDNet module current [A3] + actual NAC Current [A5] = \_\_\_\_\_