

FCR SET

# HARNETT CO DSS UPFIT 2ND FLOOR

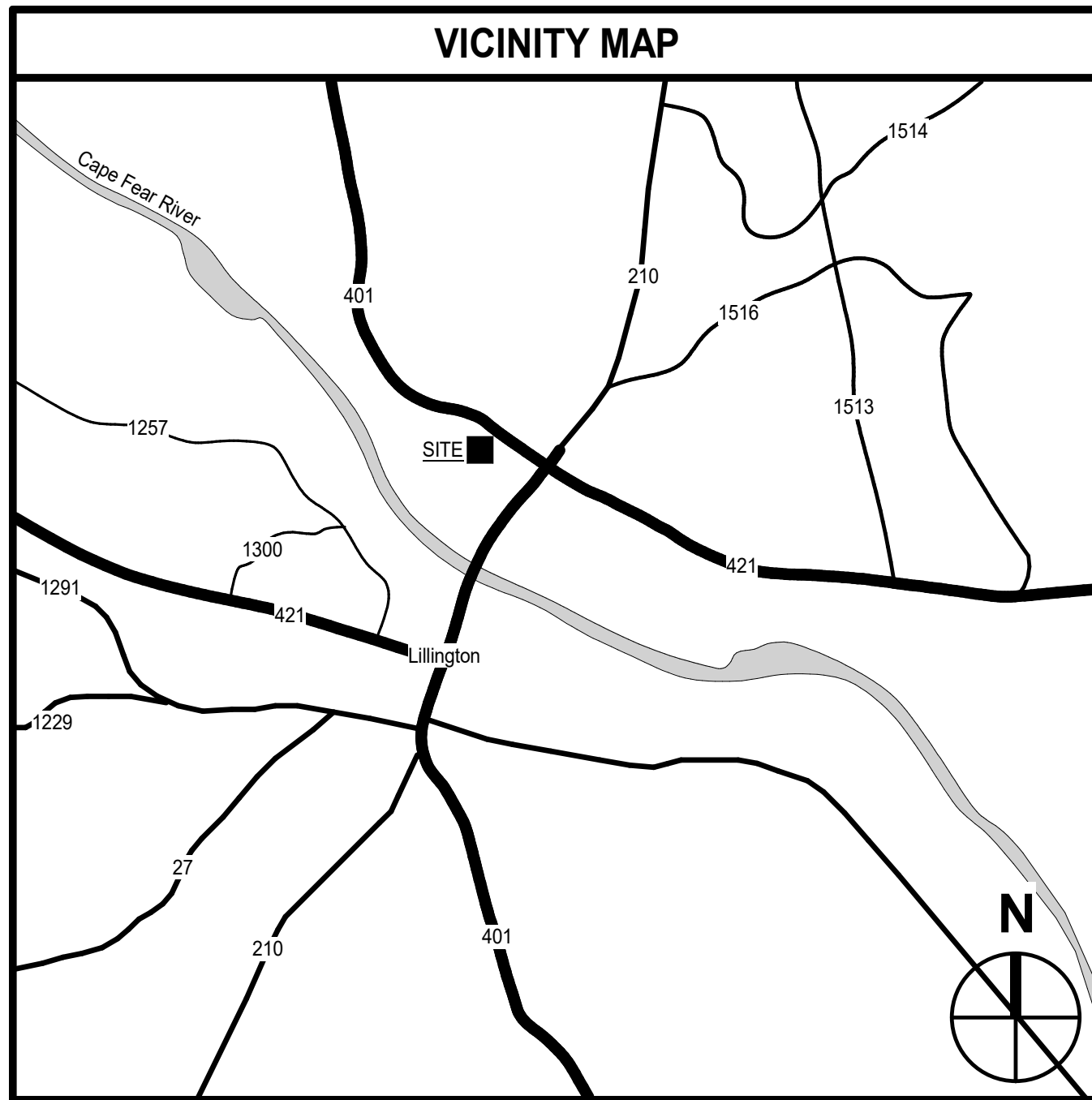

## HARNETT CO DSS LILLINGTON, NC

631797

**MOSELEY**ARCHITECTS

911 N. WEST STREET, SUITE 205 RALEIGH, NORTH CAROLINA 27603  
PHONE (919) 840-0091  
MOSELEYARCHITECTS.COM

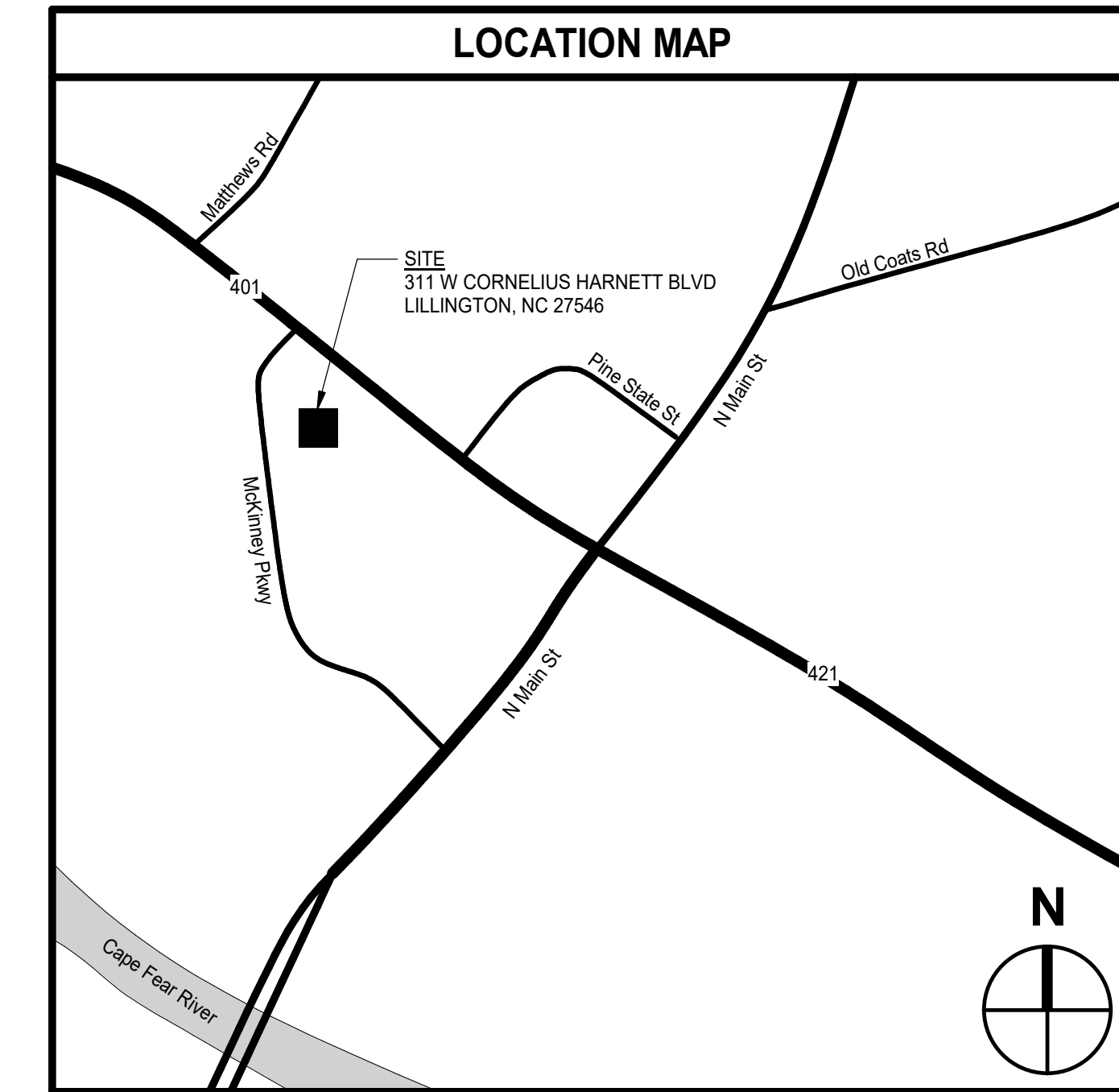

**MOSELEY**ARCHITECTS

911 N. WEST STREET, SUITE 205 RALEIGH, NORTH CAROLINA 27603  
PHONE (919) 840-0091  
MOSELEYARCHITECTS.COM



**HARNETT CO DSS UPFIT 2ND FLOOR**

631797  
HARNETT CO DSS  
311 W CORNELIUS HARNETT BLVD, LILLINGTON, NC 27546

DRAWING INDEX	
GENERAL	
G0.1	COVER
LIFE SAFETY	
LS1.0	CODE SUMMARY
LS1.1	LIFE SAFETY INFORMATION
ARCHITECTURAL	
A0.1	GENERAL ARCHITECTURAL INFORMATION
A0.2	WALL/PARTITION TYPES, WALL JOINTS AND TERMINATIONS
A1.2	DEMOLITION PLAN
A2.1	FLOOR PLAN
A3.0.1	FINISH PLAN AND FINISH SCHEDULE
A3.1.1	DOOR AND FRAME SCHEDULE, TYPES, AND DETAILS
A8.1	CASEWORK AND ELEVATIONS
A9.1	REFLECTED CEILING PLAN
FE2.1	FURNITURE PLAN
PLUMBING	
P0.1	LEGENDS, ABBREVIATIONS AND GENERAL NOTES
P1.0	PLUMBING FLOOR PLANS
MECHANICAL	
M0.1	LEGENDS, ABBREVIATIONS AND GENERAL NOTES
M0.2	SCHEDULES
M1.1	DEMOLITION PLAN
M2.1	FLOOR PLAN
M2.2	ROOF PLAN
M5.1	DETAILS AND CONTROLS
ELECTRICAL	
E0.1	LEGENDS, ABBREVIATIONS AND GENERAL NOTES
E2.0	ELECTRICAL OVERALL PLAN
E2.1	FLOOR PLANS
E5.1	DIAGRAM, SCHEDULES & DETAILS

PROJECT NO:	631797
DATE:	FEBRUARY 7, 2024
REVISIONS	
DATE	DESCRIPTION

COVER

G0.1

THE CONTRACT DOCUMENTS ARE COMPLEMENTARY, AND WHAT IS REQUIRED BY ONE SHALL BE AS BINDING AS IF REQUIRED BY ALL.  
IN CASE OF A CONFLICT, DISAGREEMENT, OR AMBIGUITY, PROVIDE THE BETTER QUALITY. IN CASE OF A CONFLICT, DISAGREEMENT, OR AMBIGUITY, PROVIDE THE GREATER QUANTITY OF WORK.

CODE DATA SUMMARY

THIS SUMMARY DOES NOT IDENTIFY ALL APPLICABLE CODE SECTIONS AND IS A SUMMARY OF SELECTED CODE SECTIONS ONLY. CODE SECTIONS NOT IDENTIFIED OR OTHERWISE INDICATED DOES NOT RELIEVE THE CONTRACTOR OF THE RESPONSIBILITY TO COMPLY WITH APPLICABLE CODES, STANDARDS, AND REGULATIONS TO COMPLETE THE WORK.

2018 APPENDIX B BUILDING CODE SUMMARY FOR ALL COMMERCIAL PROJECTS (EXCEPT 1 AND 2-FAMILY DWELLINGS AND TOWNHOUSES)

Name of Project: Harnett Co DSS Upfit of 2nd Floor Extension
Address: 311 W Cornelius Harnett Blvd, Lillington, NC Zip Code 27546
Owner/Authorized Agent: Coley Price Phone # (910) 893-7555 E-Mail: cprice@harnett.org

CONTACT: Josh Bennett, Vice President, Moseley Architects, jhbennett@moseleyarchitects.com
DESCRIPTION: FIREM
Architectural: Moseley Architects, Josh Bennett, 13947, (919)840-0091, jhbennett@moseleyarchitects.com

2018 NC BUILDING CODE: N/A
2018 NC EXISTING BUILDING CODE: Alteration Level II, N/A, N/A
CONSTRUCTED: (date) 1994 CURRENT OCCUPANCY(S) (Ch. 3): B
RENOVATED: (date) 2020 Addition Added PROPOSED OCCUPANCY(S) (Ch. 3): B

RISK CATEGORY (Table 1604.5): Current: II Proposed: II
BASIC BUILDING DATA
Construction Type: Existing Addition: Type II-B
Sprinklers: No
Standpipes: Class I, Wet
Primary Fire District: No
Special Inspections Required: No

Gross Building Area Table
FLOOR EXISTING (SF) NEW (SF) SUB-TOTAL
3rd Floor - - -
2nd Floor 5,215 SF - 5,215 SF
Mezzanine - - -
1st Floor - - -
Basement - - -
TOTAL 5,215 (SF) 0 5,215 (SF)

TOTAL SCOPE OF WORK AREA: 5,215 SF
PROJECT SCOPE OF WORK DESCRIPTION: 1st time interior completion upfit of office space to the level 2 shell space of the 2020 Addition to the existing DSS building.

ALLOWABLE AREA
Primary Occupancy Classification(s): Business
Accessory Occupancy Classification(s): N/A
Incidental Uses (Table 509):
Special Uses (Chapter 4 - List Code Sections):
Special Provisions: (Chapter 5 - List Code Sections):
Mixed Occupancy: No Separation: N/A Exception: N/A

Table with 6 columns: STORY NO., DESCRIPTION AND USE, (A) BLDG AREA PER STORY (ACTUAL), (B) TABLE 506.2 AREA, (C) AREA FOR FRONTAGE INCREASE, (D) ALLOWABLE AREA PER STORY OR UNLIMITED, (E)
1 Existing B Existing to Remain Existing to Remain Existing to Remain Existing to Remain

1 Frontage area increases from Section 506.3 are computed thus:
a. Perimeter which fronts a public way or open space having 20 feet minimum width = (F)
b. Total Building Perimeter = (P)
c. Ratio (F/P) = (F/P)
d. W = Minimum width of public way = (W)
e. Percent of frontage increase I = 100(F/P - 0.25) x W/30 = (%)
2 Unlimited area applicable under conditions of Section 507.
3 Maximum Building Area = total number of stories in the building x D (maximum 3 stories) (506.2).
4 The maximum area of open parking garages must comply with Table 406.5.4.
5 Frontage increase is based on the un sprinklered area value in Table 506.2.

ALLOWABLE HEIGHT
Table with 4 columns: ALLOWABLE, SHOWN ON PLANS, CODE REFERENCE 1
Building Height in Feet (Table 504.3) 2 Existing to Remain Existing
Building Height in Stories (Table 504.4) 1 Existing to Remain 2 Existing -

1 Provide code reference if the "Shown on Plans" quantity is not based on Table 504.3 or 504.4.
2 The maximum height of air traffic control towers must comply with Table 412.3.1.
3 The maximum height of open parking garages must comply with Table 406.5.4.

FIRE PROTECTION REQUIREMENTS
Table with 8 columns: BUILDING ELEMENT, FIRE SEPARATION DISTANCE (FEET), REQ'D, RATING PROVIDED (w/ REDUCTIONS), DETAIL # FOR RATED ASSEMBLY, SHEET # FOR RATED PENETRATION, SHEET # FOR RATED JOINTS
Structural Frame, including columns, girders, trusses: 30 0 0 (Existing) SHEET # SHEET # SHEET #
Bearing Walls: 0 N/A
Exterior: 0 N/A
North: 0 N/A
East: 0 N/A
West: 0 N/A
South: 0 N/A
Interior: 0 N/A
Nonbearing Walls and Partitions: 0 0 (Existing)
Exterior walls: 0 0 (Existing)
North: 0 0 (Existing)
East: 0 0 (Existing)
West: 0 0 (Existing)
South: 0 0 (Existing)
Interior walls and partitions: 0 0
Floor Construction: 0 0 (Existing)
Including supporting beams and joists: 0 0 (Existing)
Floor Ceiling Assembly: 0 0 (Existing)
Column Supporting Floor: 0 0 (Existing)
Roof Construction, including supporting beams and joists: 0 0 (Existing)
Roof Ceiling Assembly: 0 0 (Existing)
Column Supporting Roof: 0 0 (Existing)
Shaft Enclosures - East: 1 1 (Existing)
Shaft Enclosures - Other: 1 1 (Existing)
Curbside Separation: 0 0 (Existing)
Occupancy/Fire Barrier Separation: 1 1 (Existing)
Party/Fire Wall Separation: 0 0 (Existing)
Smoke Barrier Separation: 0 0 (Existing)
Smoke Partition: 0 0 (Existing)
Tenant Dwelling Unit Sleeping Unit Separation: N/A N/A
Incidental Use Separation: 0 0 (Existing)

\* Indicate section number permitting reduction

PERCENTAGE OF WALL OPENING CALCULATIONS
Table with 4 columns: FIRE SEPARATION DISTANCE (FEET) FROM PROPERTY LINES, DEGREE OF OPENING PROTECTION (TABLE 705.8), ALLOWABLE AREA (%), ACTUAL SHOWN ON PLANS (%)
N/A (Existing) N/A (Existing)

LIFE SAFETY SYSTEM REQUIREMENTS
Emergency Lighting: Yes
Exit Signs: Yes
Fire Alarm: Yes
Smoke Detection Systems: Yes
Carbon Monoxide Detection: Yes

LIFE SAFETY PLAN REQUIREMENTS
Life Safety Plan Sheet #: LS1.0 (NC Existing Building Code, Section 703 & 704)
Fire and/or smoke rated wall locations (Chapter 7)
Assumed and real property line locations (if not on the site plan)
Exterior wall opening area with respect to distance to assumed property lines (705.8)
Occupancy Use for each area as it relates to occupant load calculation (Table 1004.1.2)
Occupant loads for each area
Exit access travel distances (1017)
Common path of travel distances (Tables 1006.2.1 & 1006.3.2(1))
Dead end lengths (1020.4)
Clear exit widths for each exit door
Maximum calculated occupant load capacity each exit door can accommodate based on egress width (1005.3)
Actual occupant load for each exit door
A separate schematic plan indicating where fire rated floor/ceiling and/or roof structure is provided for purposes of occupancy separation
Location of doors with panic hardware (1010.1.10)
Location of doors with delayed egress locks and the amount of delay (1010.1.9.7)
Location of doors with electromagnetic egress locks (1010.1.9.9)
Location of doors equipped with hold-open devices
Location of emergency escape windows (1030)
The square footage of each fire area (202)
The square footage of each smoke compartment for Occupancy Classification I-2 (407.5)
Note any code exceptions or table notes that may have been utilized regarding the items above

ACCESSIBLE DWELLING UNITS (SECTION 1107)
Table with 8 columns: TOTAL UNITS, ACCESSIBLE UNITS REQUIRED, ACCESSIBLE UNITS PROVIDED, TYPE A UNITS REQUIRED, TYPE A UNITS PROVIDED, TYPE B UNITS REQUIRED, TYPE B UNITS PROVIDED, TOTAL ACCESSIBLE UNITS PROVIDED
N/A

ACCESSIBLE PARKING (SECTION 1106)
Table with 6 columns: LOT OR PARKING AREA, TOTAL # OF PARKING SPACES REQUIRED, TOTAL # OF PARKING SPACES PROVIDED, # OF ACCESSIBLE SPACES PROVIDED (REGULAR WITH 5' ACCESSIBLE, VAN SPACES WITH 132" ACCESSIBLE, 8' ACCESSIBLE), TOTAL # ACCESSIBLE PROVIDED
Existing - - - - Existing

PLUMBING FIXTURE REQUIREMENTS (TABLE 2902.1)
Table with 10 columns: USE, WATER CLOSETS (MALE, FEMALE, UNSEX), URINALS, LAVATORIES (MALE, FEMALE, UNSEX), SHOWERS, DRINKING FOUNTAINS, SPACE, EXIST'G, NEW, OCCUPANT LOAD UNCHANGED BY RENOVATION: Existing to Remain

SPECIAL APPROVALS
Special approval: (Local Jurisdiction, Department of Insurance, OSC, DPI, DHHS, etc., describe below)

ENERGY SUMMARY
ENERGY REQUIREMENTS:
The following data shall be considered minimum and any special attribute required to meet the energy code shall also be provided. Each Designer shall furnish the required portions of the project information for the plan data sheet. If performance method, state the annual energy cost for the standard reference design vs annual energy cost for the proposed design.

Existing building envelope complies with code: Select one Existing to Remain
Exempt Building: Select one (Unaltered portions) Provide code or statutory reference: 2018 NC ECC C501.1.1

Climate Zone: 4A
Method of Compliance: Select one (If "Other" specify source here) 2018 NC ECC Chapter 5 (Existing Buildings)

THERMAL ENVELOPE (Prescriptive method only)

Roof/Ceiling Assembly (each assembly)
Description of assembly: Existing to Remain
U-Value of total assembly:
R-Value of insulation:
Skylights in each assembly:
U-Value of skylight:
total square footage of skylights in each assembly:

Exterior Walls (each assembly)
Description of assembly: Existing to Remain
U-Value of total assembly:
R-Value of insulation:
Openings (windows or doors with glazing)
U-Value of assembly:
Solar heat gain coefficient:
projection factor:
Door R-Values:

Walls below grade (each assembly)
Description of assembly: N/A
U-Value of total assembly:
R-Value of insulation:

Floors over unconditioned space (each assembly)
Description of assembly: Existing to Remain
U-Value of total assembly:
R-Value of insulation:

Floors slab on grade
Description of assembly: Existing to Remain
U-Value of total assembly:
R-Value of insulation:
Horizontal/vertical requirement:
slab heated:

2018 APPENDIX B BUILDING CODE SUMMARY FOR ALL COMMERCIAL PROJECTS STRUCTURAL DESIGN (PROVIDE ON THE STRUCTURAL SHEETS IF APPLICABLE)

(EXISTING TO REMAIN)
DESIGN LOADS:

Importance Factors: Snow (I) N/A - Existing to Remain
Seismic (I) N/A - Existing to Remain
Live Loads: Roof N/A psf
Mezzanine N/A psf
Floor N/A psf
Ground Snow Load: N/A psf
Wind Load: Ultimate Wind Speed N/A (ASCE-7)
Exposure Category N/A

SEISMIC DESIGN CATEGORY: N/A
Provide the following Seismic Design Parameters:
Risk Category (Table 1604.5) N/A
Spectral Response Acceleration Ss N/A %g S1 N/A %g
Site Classification (ASCE 7) N/A
Data Source: N/A
Basic structural system N/A
Analysis Procedure: N/A
Architectural, Mechanical, Components anchored? N/A

LATERAL DESIGN CONTROL: N/A

SOIL BEARING CAPACITIES:
N/A psf
File size, type, and capacity N/A

2018 APPENDIX B BUILDING CODE SUMMARY FOR ALL COMMERCIAL PROJECTS MECHANICAL DESIGN (PROVIDE ON THE MECHANICAL SHEETS IF APPLICABLE)

MECHANICAL SUMMARY
MECHANICAL SYSTEMS, SERVICE SYSTEMS AND EQUIPMENT

Thermal Zone
winter dry bulb: 22.7°F
summer dry bulb: 97°F

Interior design conditions
winter dry bulb: 70°F
summer dry bulb: 75°F
relative humidity: 50% RH

Building heating load: Existing to Remain

Building cooling load: Existing to Remain

Mechanical Spacing Conditioning System
Unitary
Description of unit: N/A
heating efficiency: N/A
cooling efficiency: N/A
size category of unit: N/A
Boiler
Size category: If oversized, state reason: Existing to Remain
Chiller
Size category: If oversized, state reason: Existing to Remain

List equipment efficiencies: Existing to Remain

2018 APPENDIX B BUILDING CODE SUMMARY FOR ALL COMMERCIAL PROJECTS ELECTRICAL DESIGN (PROVIDE ON THE ELECTRICAL SHEETS IF APPLICABLE)

ELECTRICAL SUMMARY
ELECTRICAL SYSTEM AND EQUIPMENT

Method of Compliance: Energy Code - Prescriptive

Lighting schedule (each fixture type) - REFER TO LIGHT FIXTURE SCHEDULE
lamp type required in fixture
number of lamps in fixture
ballast type used in the fixture
number of ballasts in fixture
total wattage per fixture
total interior wattage specified vs. allowed - 0.675 w/sqft vs 0.82 (whole building)
total exterior wattage specified vs. allowed

Additional Efficiency Package Options (When using the 2018 NCC; not required for ASHRAE 90.1)
C406.2 More Efficient HVAC Equipment Performance
C406.3 Reduced Lighting Power Density
C406.4 Enhanced Digital Lighting Controls
C406.5 On-Site Renewable Energy
C406.6 Dedicated Outdoor Air System
C406.7 Reduced Energy Use in Service Water Heating

MOSELEY ARCHITECTS
911 N. WEST STREET, SUITE 205 RALEIGH, NORTH CAROLINA 27603
PHONE (919) 840-0891
MOSELEYARCHITECTS.COM



HARNETT CO DSS UPFIT 2ND FLOOR
631797
HARNETT CO DSS
311 W CORNELIUS HARNETT BLVD, LILLINGTON, NC 27546

PROJECT NO: 631797
DATE: FEBRUARY 7, 2024
REVISIONS
DATE DESCRIPTION

**LIFE SAFETY - SECOND FLOOR PLAN**  
1/4" = 1'-0"



**LIFE SAFETY SYMBOL LEGEND**  
APPLIES TO LS SERIES OF DRAWINGS ONLY

DESIGNATOR MATRIX				SYMBOLS	
	WALL	BARRIER	PARTITION	RATED BEARING OR NON-BEARING WALL	
1 HR FIRE	▬	▬▬▬▬	▬▬▬▬▬▬	▬▬▬▬▬▬▬▬	1205 ROOM NUMBER

NOTES:  
 1. WALL DESIGNATIONS ON THE LS SERIES OF DRAWINGS ARE FOR GRAPHICAL PURPOSES ONLY AND MAY NOT REPRESENT THE ACTUAL WALL/PARTITION CONSTRUCTION.  
 2. REFER TO THE CONTRACT DOCUMENTS, INCLUDING THE LIFE SAFETY SYMBOLS LEGEND AND A0, A1 AND A2 SERIES OF DRAWINGS, FOR ACTUAL WALL/PARTITION TYPES AND CONSTRUCTION REQUIREMENTS.  
 3. ALL RATED CONSTRUCTION SHOWN ON THE DRAWINGS ARE EXISTING AND HAVE BEEN PREVIOUSLY PERMITTED.

788 1280 DIRECTION OF EGRESS  
 EGRESS LOAD CAPACITY  
 NUMBER OF OCCUPANTS

174'-0"  
 TD EXIT ACCESS TRAVEL DISTANCE

◆ FIRE EXTINGUISHER CABINET

**OCCUPANCY SCHEDULE**

SPACE NUMBER	SPACE NAME	USE CLASSIFICATION	USED TO DETERMINE OCCUPANCY FACTOR ONLY	FLOOR AREA PER OCCUPANT	AREA		OCCUPANCY LOAD		
					SF	GROSS	NET	TABULAR	ACTUAL
201	MECHANICAL	S1	ACCESSORY STORAGE & MECHANICAL EQUIPMENT ROOM	300 SF	483	•	2	2	2
202	FLEX SPACE	S1	BUSINESS AREA	100 SF	188	•	2	2	2
203	CIRCULATION	B	BUSINESS AREA	100 SF	353	•	4	2	4
204	RECEPTION	B	BUSINESS AREA	100 SF	82	•	1	1	1
205	OFFICE	B	BUSINESS AREA	100 SF	91	•	1	1	1
206	WORK	B	BUSINESS AREA	100 SF	82	•	1	1	1
207	CONFERENCE	B	BUSINESS AREA	100 SF	263	•	3	10	10
208	DEPUTY DIRECTOR	B	BUSINESS AREA	100 SF	191	•	2	2	2
209	DIRECTOR	B	BUSINESS AREA	100 SF	191	•	2	2	2
210	OFFICE	B	BUSINESS AREA	100 SF	103	•	2	2	2
211	OFFICE	B	BUSINESS AREA	100 SF	103	•	2	2	2
212	OPEN OFFICE	B	BUSINESS AREA	100 SF	2019	•	21	21	21
213	BREAK ROOM	B	BUSINESS AREA	100 SF	395	•	4	4	4
214	SUPERVISOR	B	BUSINESS AREA	100 SF	107	•	2	2	2
215	SUPERVISOR	B	BUSINESS AREA	100 SF	102	•	2	2	2
216	FLEX SPACE	S1	BUSINESS AREA	100 SF	212	•	3	2	2
								60	

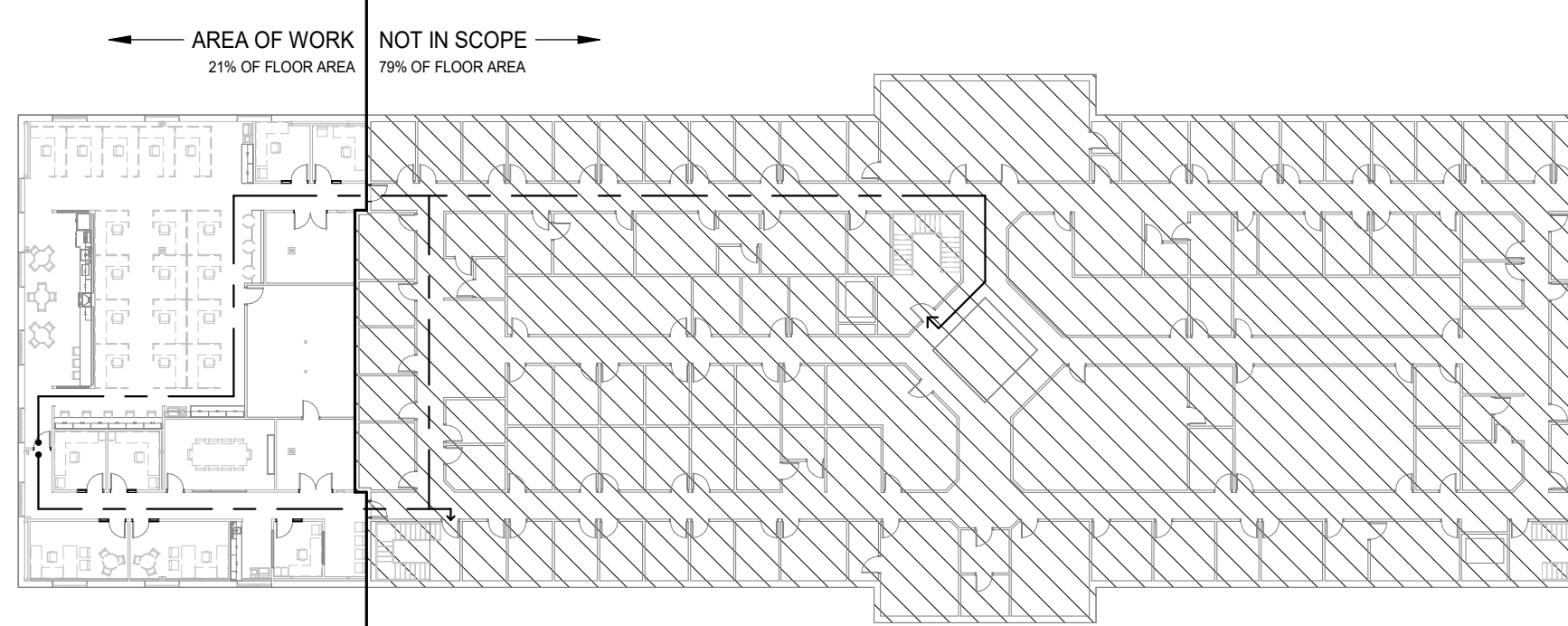

**LIFE SAFETY - SECOND FLOOR PLAN OVERALL**  
1/32" = 1'-0"



**HARNETT CO DSS UPFIT 2ND FLOOR**  
 631797  
 HARNETT CO DSS  
 311 W CORNELIUS HARNETT BLVD, LILLINGTON, NC 27546

PROJECT NO:	631797
DATE:	FEBRUARY 7, 2024
REVISIONS	
DATE	DESCRIPTION



PROJECT NO:	631797
DATE:	FEBRUARY 7, 2024
REVISIONS	
DATE	DESCRIPTION

**ARCHITECTURAL ABBREVIATIONS**

A-PT ACCENT PAINT	CMU-GLZ CONCRETE MASONRY UNIT - GLAZED	EPS EXPANDED POLYSTYRENE	GYP GYPSUM	MFR MULTICOLOR INTERIOR FINISHING	PVVC PERFORATED VINYL WALL COVERING	SYM SYMMETRICAL
ABS AIR BARRIER SYSTEM	CMU-SPLF CONCRETE MASONRY UNIT - SPLIT FACE	EPX EPOXY	H HIGH	MIN MINIMUM	OSM QUARTZ SURFACING MATERIAL	T TREAD
ABV ABOVE	COL COLUMN	EQ EQUIP	HB HOSE BIBB	MIR MIRROR	QT QUARRY TILE	T&G TONGUE & GROOVE
ACP ACOUSTICAL CEILING PANEL	COL COLUMN	EQP EQUIPMENT	HBD HOLD DOWN	MISC MISCELLANEOUS	QTY QUANTITY	T.O. TOP OF
ACT ACOUSTICAL CEILING TILE	CONC CONCRETE	FR FRAMING	HDC HOLD DOWN CLIPS	R RISER	R RISER	TB TACKBOARD
ACW ALUMINUM CLAD WINDOW	CONC-LH CONCRETE WITH LIQUID HARDENER/SEALER	EVCT ENHANCED VINYL COMPOSITION TILE	HDNR HARDENER	MLDG MOLDING	RWD RIGHT OF WAY	TCF TEXTILE COMPOSITE FLOORING
ADJ ADJUSTABLE	HARDW/SEALR HARDWARE/SEALER	EWC ELECTRIC WATER COOLER	HDWR HARDWARE	MO MASONRY OPENING	RWD RADIUS	TEL TELEPHONE
AFF ABOVE FINISHED FLOOR	CONC-FMT CONCRETE WITH PIGMENT	EX EXISTING	HDWR HARDWARE	MPS MANUAL PROJECTION SCREEN	RAF RESILIENT ATHLETIC FLOORING	TERR-C TERRAZZO CEMENTITIOUS
AHU AUTHORITY HAVING JURISDICTION	CONC-POL CONCRETE - POLISHED	EXH EXHAUST	HM HOLLOW METAL	MR MAP RAIL	RB RESILIENT BASE	TERR-E TERRAZZO EPOXY
AHU AIR HANDLING UNIT	CONC-SLR CONCRETE WITH CURE & SEAL	EXP EXPANSION	HORIZ HORIZONTAL	MT MOUNT	RECB REFLECTED CEILING PLAN	TERR-R TERRAZZO RUBBERIZED
ALT ALTERNATE	CONC-ST CONCRETE WITH STAIN	EXPC EXPOSED CONSTRUCTION	HPC HIGH PERFORMANCE COATINGS	MTD MOUNTED	RCD ROOF DRAIN	THD THRESHOLD
ALUM ALUMINUM	CONSTR CONSTRUCTION	EXT EXTERIOR	HPPF HIGH PERFORMANCE FLOOR PAINT	MTL METAL	REFG REFRIGERATOR	THK THICKNESS, THICK
AP ACCESS PANEL	CONT CONTINUOUS	FAAF FLUID APPLIED ATHLETIC FLOORING	HT HEIGHT	NA NOT APPLICABLE	REIN REINFORCING, REINFORCE(D)	TOS TOP OF STEEL
APC ARCHITECTURAL PRECAST CONCRETE	CONTR CONTRACTOR	FD FLOOR DRAIN	HVAC HEATING, VENTILATING, AIR CONDITIONING	NIC NOT IN CONTRACT	REIN RECESSED ENTRY MAT	TOW TOP OF WALL
ARC ABUSE RESISTANT COATING	CORR CORRIDOR	FDN FOUNDATION	INFO INFORMATION	NO NUMBER	REQD REQUIRED	TS TACK STRIP
AS ALUMINUM STOREFRONT	CSMU CAST STONE MASONRY UNIT	FE FIRE EXTINGUISHER	ID INSIDE DIAMETER	NOM NOMINAL	RES RESINOUS FLOORING	TV TELEVISION
AUTO AUTOMATIC	CT CERAMIC TILE	FEB FIRE EXTINGUISHER BRACKET	IN INCH, INCHES	NRC NOISE REDUCTION COEFFICIENT	RFT RUBBER FLOOR TILE	TYP TYPICAL
AVG AVERAGE	CTSK COUNTERSINK, COUNTERSUNK	FEC FIRE EXTINGUISHER CABINET	INCL INCLUDE, INCLUDING	NTS NOT TO SCALE	RH RIGHT HAND	UC UNDERCUT
AW ALUMINUM WINDOW	CUFFT CUBIC FEET / FOOT	FF FINISHED FLOOR	INFO INFORMATION	OC ON CENTER	RL RAIN LEADER	UG UNDERGROUND
AWC ACOUSTICAL WALL COVERING	CORR CORRIDOR	FGL FIBERGLASS	INST INSTALLATION	OD OUTSIDE DIAMETER	RM ROOM	UH UNIT HEATER
AWP ACOUSTICAL WALL PANEL	CW ALUMINUM CURTAIN WALL	FH FIRE HYDRANT	INSUL INSULATION	OCFJ OWNER FURNISHED CONTRACTOR	RO ROUGH OPENING	UNO UNLESS NOTED (INDICATED) OTHERWISE
BD BOARD	CWFD CEMENTITIOUS WOOD FIBER DECK	FHC FIRE HOSE CABINET	INT INTERIOR	INT INTERIOR	RSF RUBBER SHEET FLOORING	VAT VAPOR BARRIER
BF BARRIER FREE (ADA or A117.1)	D DEPTH/DEEP	FHV FIRE HOSE VALVE CABINET	IRWC IMPACT RESISTANT WALL COVERING	OPNG OPENING	RSR RESILIENT STAIR RISER	VB VAPOR BARRIER
BLDG BUILDING	DBL DOUBLE	FIN FINISHED FLOOR	IRWB INTERACTIVE WHITE BOARD	OPPHD OPPOSITE HAND	RST RESILIENT STAIR TREAD	VCT VINYL COMPOSITION TILE
BLKG BLOCKING	DEMO DEMOLITION	FLR FLOOR	JAN JANITOR	OVDH OVERHEAD	RT RIGHT	VDB VISUAL DISPLAY BOARD
BOT BOTTOM	DETE DETENTION	FLRG FLOORING	JCT JUNCTION	P-TILE PORCELAIN TILE	RTU ROOFTOP UNIT	VERT VERTICAL
BRG BEARING	DF DRINKING FOUNTAIN	FO FACE OF	JOINT JOINT	PRECAST PRECAST	SAB SOUND ATTENUATION BLANKET	VEST VESTIBULE
BTWN BETWEEN	DG DOOR GRILLE	FRM FRAME	L LENGTH/LONG	PERF PERFORATED, PERFORATION(S)	SC-PLK SECURITY CEILING PLANK	VFCF VINYL FREE COMPOSITION TILE
BUR BUILT-UP ROOF	DHM DETENTION HOLLOW METAL	FRP FIBERGLASS REINFORCED PLASTIC	LAB LABORATORY	PERIM PERIMETER	SC-PNL SECURITY CEILING PANEL	VFWC VINYL FREE WALLCOVERING
C CARPET	DIA DIAMETER	FRT FIRE RETARDANT TREATED	LAHJ LOCAL AUTHORITY HAVING JURISDICTION	PFP POURED IN PLACE	SCH SCHEDULE	VR VAPOR RETARDER
C-TILE CARPET TILE	DIAG DIAGONAL	FT FOOT, FEET	LAM LAMINATE	PLAM PLASTIC LAMINATE	SF SQUARE FEET / FOOT	VT VINYL TILE
CAB CABINET	DM DIMENSION	FTG FOOTING	LAV LAVATORY	PLAS PLASTER	SFRM SPRAYED FIRE RESISTANT MATERIAL	VTR VENT THROUGH ROOF
CB CORKBOARD	DIV DIVISION	FURN FURNITURE	LH LEFT HAND	PLWD PLASTIC LAMINATE WOOD	SHM SECURITY HOLLOW METAL	VW VINYL WINDOW
CCTV CLOSED CIRCUIT TELEVISION	DL DOWN LOUVER	FVC FIRE VALVE CABINET	LIN LINOLEUM	PLYWD PLYWOOD	SHW SHEATHING	VWC VINYL WALL COVERING
CEM CEMENT	DN DOWN	FWC FABRIC WALL COVERING	LKR LOCKER	PND PANEL PANELING	SIM SIMILAR	W WIDE, WIDTH
CFSF-NS COLD FORMED STEEL FRAMING, NON-STRUCTURAL	DP DAMP-PROOFING	GA GAUGE	LMC LINEAR METAL CEILING	POLY POLYETHYLENE	SPEC SPECIFICATION	W/ WITH
CFSF-S COLD FORMED STEEL FRAMING, STRUCTURAL	DR DISPLAY RAIL	GAL GALLON	LPS LAMINATE PANEL SYSTEM	PPS SPRAYED POLYURETHANE FOAM	SPF SPRINKLER	W/O WITHOUT
CG CORNER GUARD	DS DOWNSPOUT	GALV GALVANIZED	LT LIGHT	SPR SPRINKLER	SPR SPRINKLER	WC WATER CLOSET
CI CONTINUOUS INSULATION	DWG DRAWING	GB-AR GYPSUM BOARD - ABUSE RESISTANT	LVR LOUVER	SO SQUARE	SO FT SQUARE FEET / FOOT	WCP WOOD CEILING PANEL
CIPC CAST IN PLACE CONCRETE	DWR DRAWER	GB-IR GYPSUM BOARD - IMPACT RESISTANT	M METER	SO FT SQUARE FEET / FOOT	SRD SECONDARY ROOF DRAIN	WDW WINDOW
CJ CONTROL JOINT	EA EACH	GB-S GYPSUM BOARD - SECURITY	MACH MACHINE	SS STAINLESS STEEL	SS STAINLESS STEEL	WDP WATERPROOFING
CLG CEILING	EF EXHAUST FAN	GRD GLASS FIBER REINFORCED CONCRETE	MAS MASONRY	SSM SOLID SURFACE MATERIAL	SSM SOLID SURFACE MATERIAL	WPT WORKING POINT
CLR CLEAR	EFSS EXTERIOR FINISH SYSTEM	GRLG GLASS GLAZING	MATL MATERIAL	ST STREET	STC SOUND TRANSMISSION COEFFICIENT	WSCT WAINSCOT
CM CENTIMETER	EJ EXPANSION JOINT	GL-BLK GLASS BLOCK	MB MARKERBOARD	STD STANDARD	STC SOUND TRANSMISSION COEFFICIENT	WSF WOOD SPORTS FLOORING
CMBD CEMENT BOARD	EL ELEVATION	GPM GALLONS PER MINUTE	MCM METAL COMPOSITE MATERIAL	STL STEEL	STD STANDARD	WT WEIGHT
CMU CONCRETE MASONRY UNIT	ELAS ELASTOMERIC	GRT GROUT	MCP METAL CEILING PANEL	STRUC STRUCTURAL	STL STEEL	WWF WELED WIRE FABRIC
CMU-A CONCRETE MASONRY UNIT - ACOUSTICAL	ELEC ELECTRICAL	GT GLAZED STRUCTURAL FACING TILE	MED MEDIUM	SUSP SUSPENDED	STL STEEL	XPS EXTRUDED POLYSTYRENE
CMU-GF CONCRETE MASONRY UNIT - GROUND FACE	EMER EMERGENCY	GWT GLAZED WALL TILE	MEMB MEMBRANE	SV SHEET VINYL	SV SHEET VINYL	

**KEYNOTES**

- KEYNOTE (1 TO 2 DIGITS)
- KEYNOTE (3 DIGITS ONLY)
- SIZE, THICKNESS, OR OTHER DESCRIPTIVE INFORMATION

**ARCHITECTURAL GRAPHIC SYMBOL LEGEND**

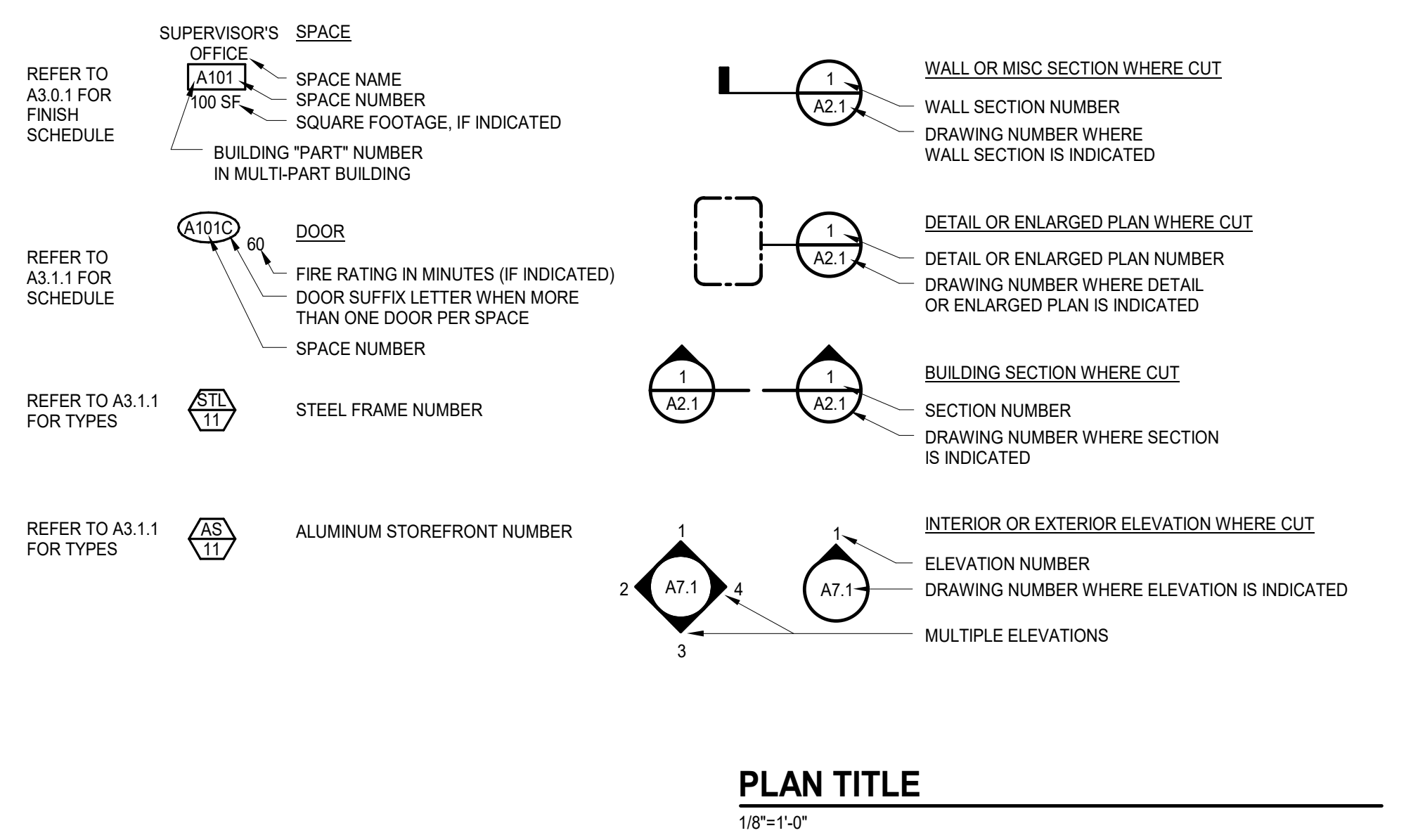

**PLAN TITLE**

1/8"=1'-0"

**ELEVATION OR BUILDING SECTION TITLE**

1/4"=1'-0"

**ENLARGED PLAN OR WALL SECTION TITLE**

1/4"=1'-0"

**DETAIL TITLE**

1/2"=1'-0"

**CASEWORK TITLE**

1/4"=1'-0"

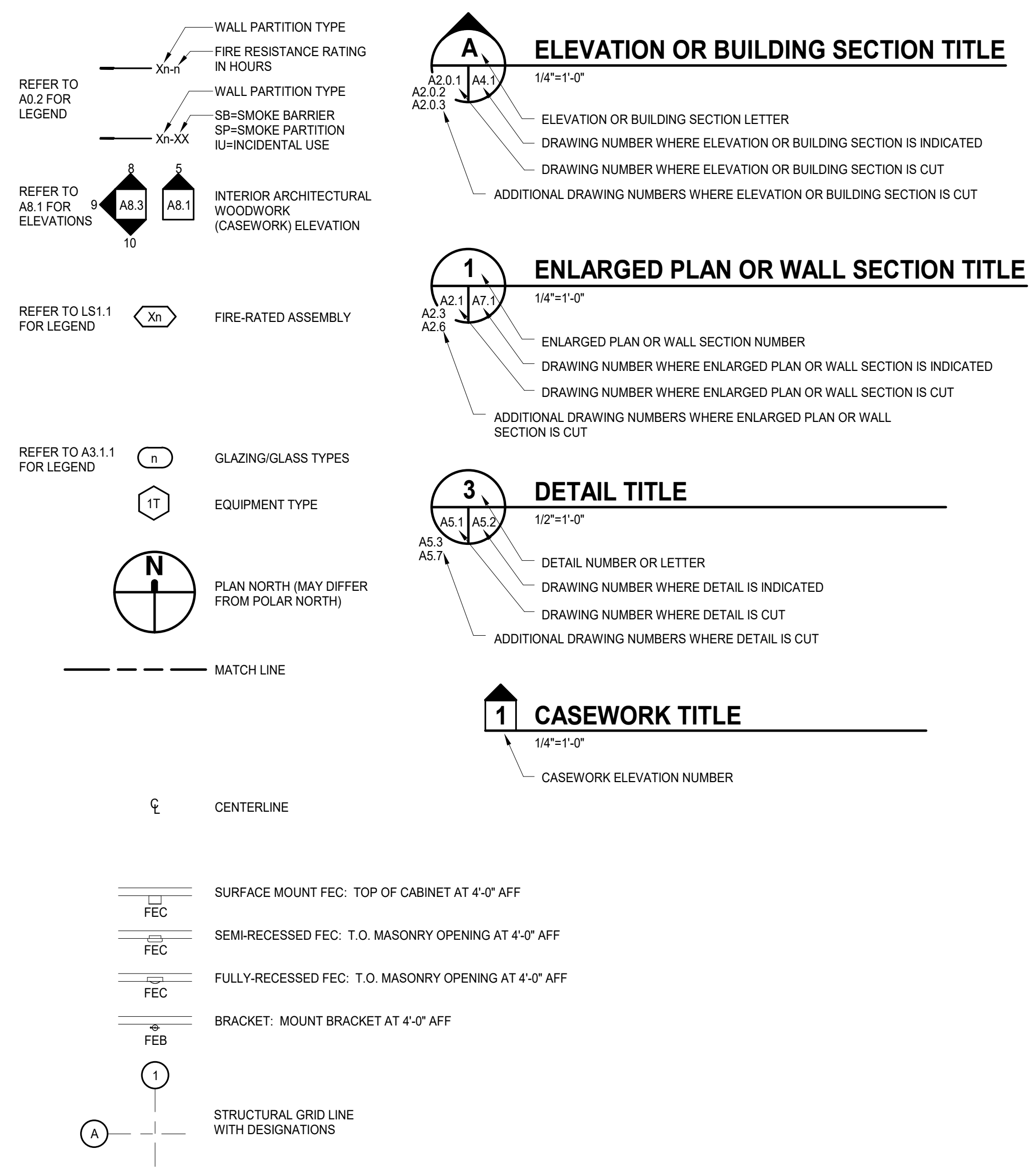

**ARCHITECTURAL GENERAL NOTES**

- THE CONTRACT DOCUMENTS ARE COMPLEMENTARY AND WHAT IS REQUIRED BY ONE SHALL BE AS BINDING AS IF REQUIRED BY ALL. IN THE CASE OF A CONFLICT, DISAGREEMENT, OR AMBIGUITY, PROVIDE THE BETTER QUALITY. IN THE CASE OF A CONFLICT, DISAGREEMENT, OR AMBIGUITY, PROVIDE THE GREATER QUANTITY OF WORK.
- ELEMENTS THAT ARE IDENTIFIED BY OTHER DISCIPLINES (E.G., CIVIL, STRUCTURAL, PLUMBING, FIRE PROTECTION, MECHANICAL, ELECTRICAL) ELSEWHERE WITHIN THE ARCHITECTURAL SERIES OF DRAWINGS AND/OR SPECIFICATIONS, OR IDENTIFIED OR COVERED BY DEFAULTS (E.G., SIZES, THICKNESS, SPACING, MATERIALS) IN THE SPECIFICATIONS MAY NOT BE ANNOTATED (NOTE OR KEYNOTED) ON THESE DRAWINGS.
- ELEMENTS IDENTIFIED IN "LEGENDS" AND/OR "GENERAL NOTES" MAY NOT BE NOTED IN DETAILS OR SECTIONS, AS THESE ELEMENTS ARE IDENTIFIED IN THE LEGENDS (E.G. FACE BRICK, CMU, WINDOWS).
- REFER TO "ASSEMBLIES" FOR MATERIALS AND COMPONENTS THAT MAKE UP THAT PARTICULAR ASSEMBLY (E.G., EXTERIOR WALL ASSEMBLIES, ROOF ASSEMBLIES, AND FIRE-RATED ASSEMBLIES). ONCE A PARTICULAR ASSEMBLY HAS BEEN IDENTIFIED ON ONE DRAWING, THAT SAME ASSEMBLY GRAPHIC SHALL APPLY TO ALL OTHER SIMILAR LOCATIONS UNLESS SPECIFICALLY INDICATED OTHERWISE. PROVIDE THAT SAME ASSEMBLY AT THE SIMILAR LOCATION WHETHER THE ASSEMBLY GRAPHIC SYMBOL IS SHOWN OR NOT.
- VERIFY ALL DIMENSIONS, INCLUDING DIMENSIONS ON STRUCTURAL DRAWINGS AND OTHER ARCHITECTURAL DRAWINGS. IMMEDIATELY NOTIFY ARCHITECT OF ANY DISCREPANCIES.
- PROVIDE CONCRETE HOUSEKEEPING PADS FOR ALL EQUIPMENT INDICATED TO BE MOUNTED OR OTHERWISE REQUIRED TO BE MOUNTED TO THE FLOOR, WHERE PADS ARE NOT SHOWN, PROVIDE 6" THICK CONCRETE PADS W/ 3/4" CHAMFERED EDGES (ALL SIDES). REINFORCE WITH MESH EQUIVALENT TO FLOOR SLAB REINFORCING REQUIREMENTS.

**ARCHITECTURAL MATERIALS LEGEND**

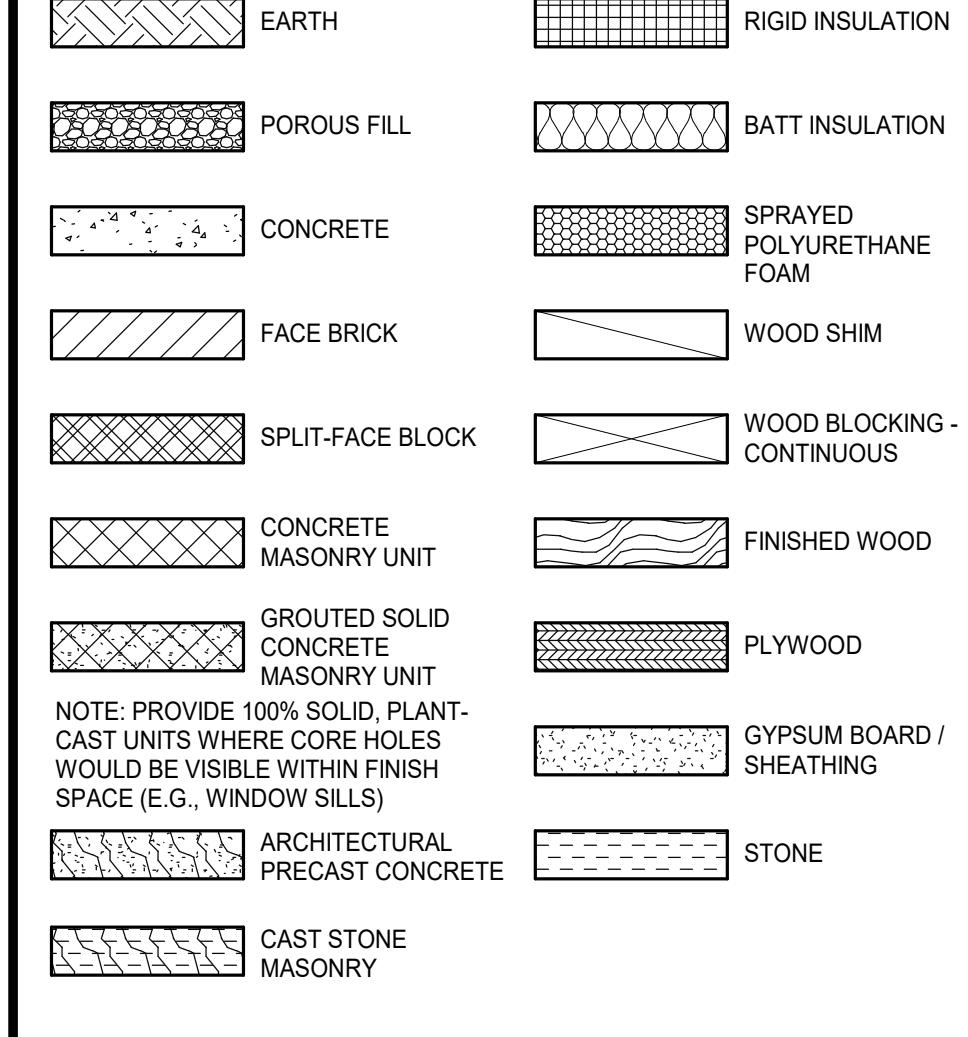

**ARCHITECTURAL SITE PLAN**

1" = 50'-0"

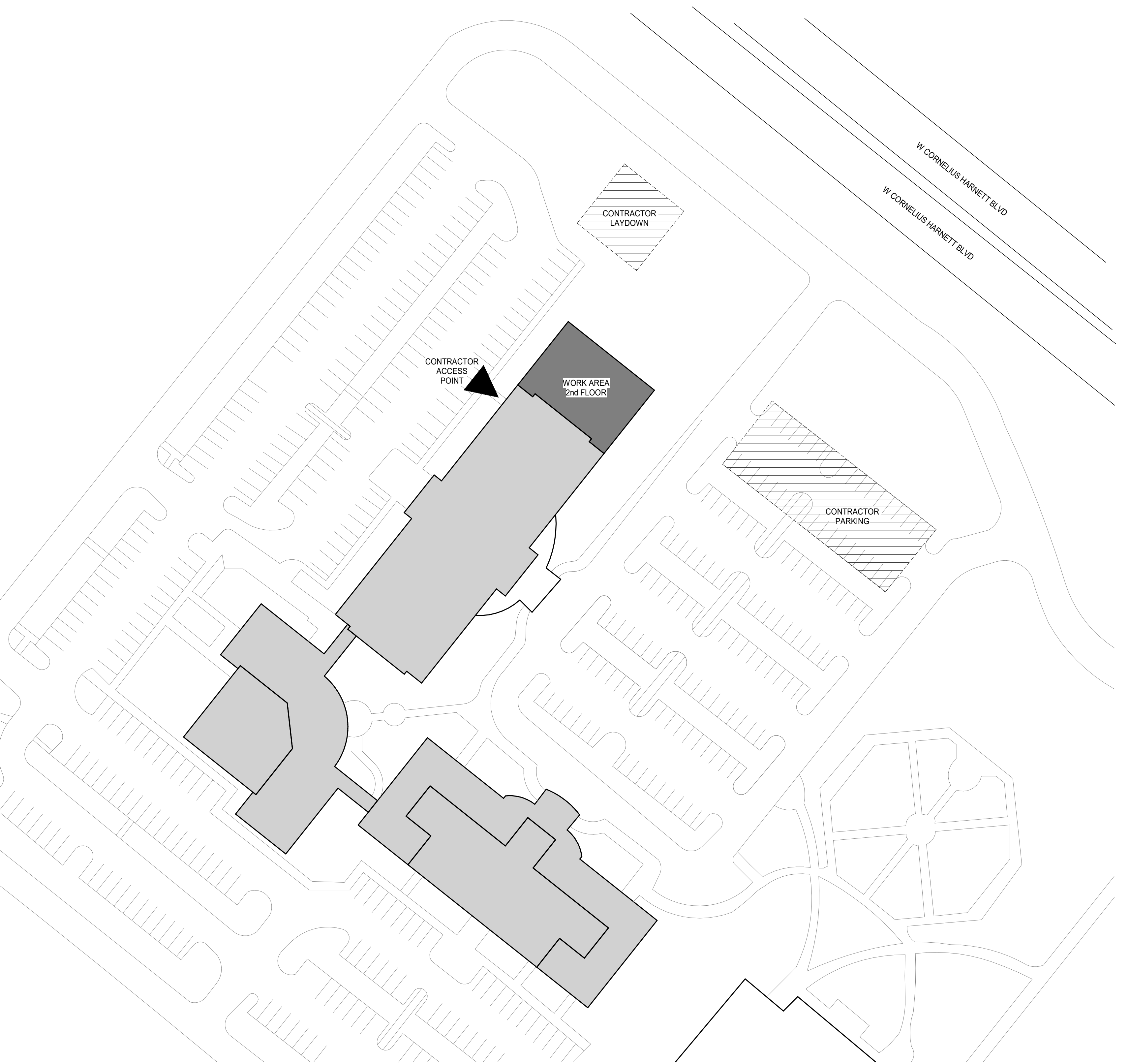



PROJECT NO:	631797
DATE:	FEBRUARY 7, 2024
REVISIONS	
DATE	DESCRIPTION

**TERMINATION GENERAL NOTES**

- A. AT FIRE-, SMOKE-, AND ACOUSTICALLY RATED WALLS: SEAL ALL NON-OBSTRUCTED HEAD-OF-WALL CONDITIONS IN ACCORDANCE WITH JOINT SYSTEM MANUFACTURER'S RECOMMENDATIONS BASED ON CONDITION ENCOUNTERED (E.G., CMU-TO-DECK (PARALLEL OR PERPENDICULAR TO FLUTES), OR CFSF-TO-DECK (PARALLEL OR PERPENDICULAR TO FLUTES) TO MAINTAIN ASSEMBLY RATING CONSISTENT WITH WALL/PARTITION REQUIREMENTS. BRACE WALL AS INDICATED OR REQUIRED.
- B. AT ALL OTHER WALLS INDICATED TO EXTEND TO UNDERSIDE OF FLOOR/ROOF DECK/CAP: SEAL ALL NON-OBSTRUCTED HEAD-OF-WALL CONDITIONS IN ACCORDANCE WITH JOINT SYSTEM MANUFACTURER'S RECOMMENDATIONS BASED ON CONDITION ENCOUNTERED (E.G., CMU-TO-DECK (PARALLEL OR PERPENDICULAR TO FLUTES), OR CFSF-TO-DECK (PARALLEL OR PERPENDICULAR TO FLUTES), OR CFSF-TO-DECK (PARALLEL OR PERPENDICULAR TO FLUTES), BRACE WALL AS INDICATED OR REQUIRED.
- C. AT ALL WALLS PREVENTED FROM TERMINATING AT THE UNDERSIDE OF FLOOR/ROOF DECK BY OBSTRUCTIONS, COMPLY WITH THE FOLLOWING:
  - AT FIRE-, SMOKE-, AND ACOUSTICALLY-RATED WALLS: ENCASE OBSTRUCTION(S) TO MAINTAIN ASSEMBLY RATING CONSISTENT WITH WALL/PARTITION REQUIREMENTS.
  - AT SECURITY WALLS: TERMINATE IN ACCORDANCE WITH SECURITY PARTITION REQUIREMENTS.
  - AT OTHER WALLS: ENCASE OBSTRUCTION(S) ON ONE SIDE.
  - SEAL ENCASUREMENT TO WALL AND SEAL ENCASUREMENT TO DECK IN ACCORDANCE WITH JOINT SYSTEM MANUFACTURER'S RECOMMENDATIONS AND TO MAINTAIN ASSEMBLY RATING CONSISTENT WITH WALL/PARTITION REQUIREMENTS.

**WALL/PARTITION TYPE GENERAL NOTES**

- A. PLAN DIMENSIONS ARE TO FACE OF WALL OR PARTITION. WHERE APPLIED FINISHES OCCUR SUCH AS CERAMIC TILE-DIMENSIONS ARE TO FACE OF APPLIED FINISH. FOR WAINSCOTS, FLOOR PLAN DIMENSIONS ARE TO FACE OF WAINSCOT MATERIAL. APPLIED FINISHES ARE NOT ALLOWED TO REDUCE CLEAR DIMENSIONS. "APPLIED FINISHES" IN THIS CASE DO NOT INCLUDE TRIM, BASE, AND ACOUSTIC WALL PANELS.
- B. EXTEND WALL/PARTITION ASSEMBLY COMPONENTS FULL HEIGHT OF ASSEMBLY.
- C. ALL INTERIOR CFSF PANEL PARTITIONS: P1 UNLESS INDICATED OTHERWISE.
- D. THE TERMS "WALL" AND "PARTITION" MAY BE USED INTERCHANGEABLY THROUGHOUT THE CONTRACT DOCUMENTS.
- E. EXTEND ALL FIRE-, SMOKE-, INCIDENTAL USE, AND ACOUSTICALLY-RATED WALLS/PARTITIONS TO UNDERSIDE OF FLOOR DECK, ROOF DECK, STRUCTURAL ELEMENT ENCASUREMENT OR SOLID CAP ABOVE.
  - SEAL AND TERMINATE IN ACCORDANCE WITH JOINT SYSTEM TESTED ASSEMBLIES FOR RESPECTIVE TYPE OF WALLS/PARTITIONS.
- F. PARTITIONS THAT DO NOT EXTEND TO UNDERSIDE OF DECK OR CAP ABOVE:
  - EXTEND 4 INCHES MINIMUM ABOVE HIGHEST ADJACENT FINISH CEILING UNLESS INDICATED OTHERWISE.
- G. SEAL AROUND ALL PENETRATIONS.
- H. COMPLY WITH TERMINATION, WALL JOINT, AND MISCELLANEOUS DETAILS FOR THOSE CONDITIONS WHERE APPLICABLE. COMPLY WITH REFERENCED STANDARDS WHERE DETAILS ARE NOT IDENTIFIED IN THE DRAWINGS.
- I. WALL/PARTITION TYPES DO NOT ADDRESS WALL FINISHES. REFER TO FINISH SCHEDULE.
- J. FINISHED SPACES: PROVIDE CHASES AROUND ALL EXPOSED VERTICAL COMPONENTS, INCLUDING BUT NOT LIMITED TO: DUCTWORK, PIPING, AND CONDUIT, UNLESS COMPONENTS ARE SPECIFICALLY INDICATED TO REMAIN EXPOSED. IF NOT OTHERWISE INDICATED, PROVIDE P2 CHASE CONSTRUCTION.
  - HOLD CHASES TIGHT TO COMPONENTS ALLOWING FOR ACCESS, INSULATION, AND TOLERANCES.
  - EXTEND CHASES FROM FLOOR TO 4 INCHES MINIMUM ABOVE FINISH CEILING OR IF NO CEILING IS INDICATED, EXTEND CHASES TO UNDERSIDE OF FLOOR DECK, ROOF DECK, OR SOLID CAP ABOVE AND TERMINATE ACCORDINGLY.
- K. PROVIDE BACKER BOARD UNIT OF SAME THICKNESS INDICATED IN LIEU OF GYPSUM BOARD PANEL AT PORTIONS OF WALLS/PARTITIONS TO RECEIVE TILE.
- L. PROVIDE TESTED JOINT ASSEMBLIES AT FIRE-, SMOKE-, AND ACOUSTICALLY-RATED WALLS.
- M. REFER TO SPECIFICATIONS FOR ADDITIONAL WALL JOINT REQUIREMENTS.
- N. PROVIDE CORNERGUARDS AT ALL OUTSIDE CORNER LOCATIONS. REFER TO SPECIFICATION FOR ADDITIONAL INFORMATION.

**TERMINATIONS**

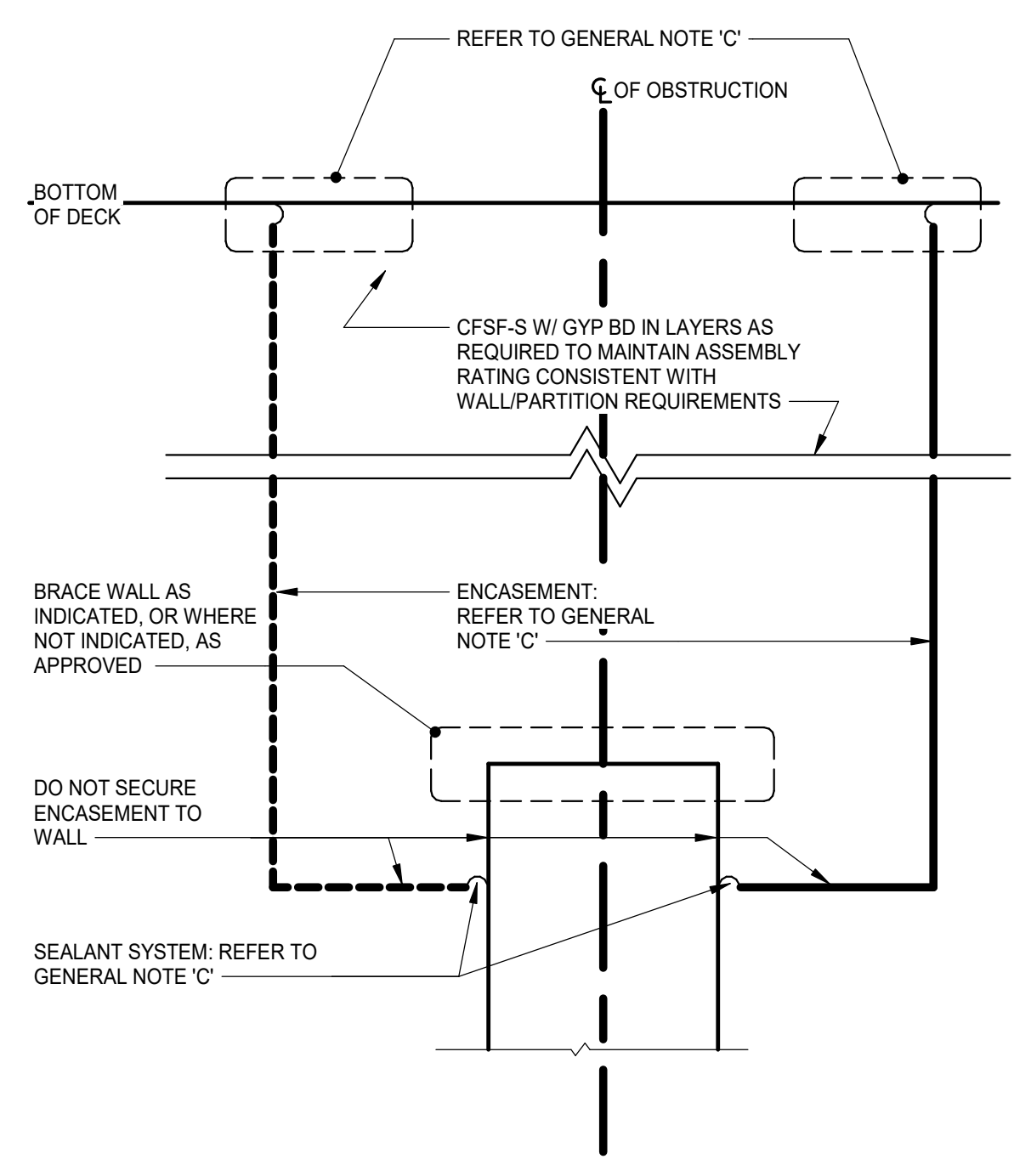

**HEAD-OF-WALL TERMINATION @ OBSTRUCTION**

OBSTRUCTION MAY VARY (BEAM, JOIST, GIRDER, CHANNEL, DUCTWORK, PIPING)

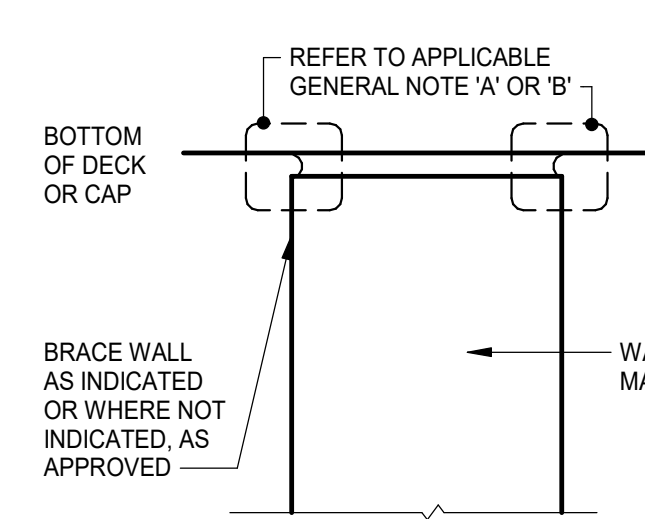

**HEAD-OF-WALL TERMINATION @ NON-OBSTRUCTION**

**PANEL WALL/PARTITION TYPES**

MARK	FIRE RATED ASSEMBLY (REFER TO LS 1.1 FOR LEGEND)	REMARKS	INFORMATION
P1 P1a	⊖	-	4 7/8" 5/8" GYP BD 3-1/2" SAB 3-5/8" CFSF-NS 3-5/8" CFSF-S @ P1a
P2 P2a	⊖	-	4 1/4" 5/8" GYP BD 3-1/2" SAB @ P2a 3-5/8" CFSF-NS
P3	⊖	-	7 1/4" 5/8" GYP BD 5-1/2" SAB 6" CFSF-S

**WALL JOINTS**

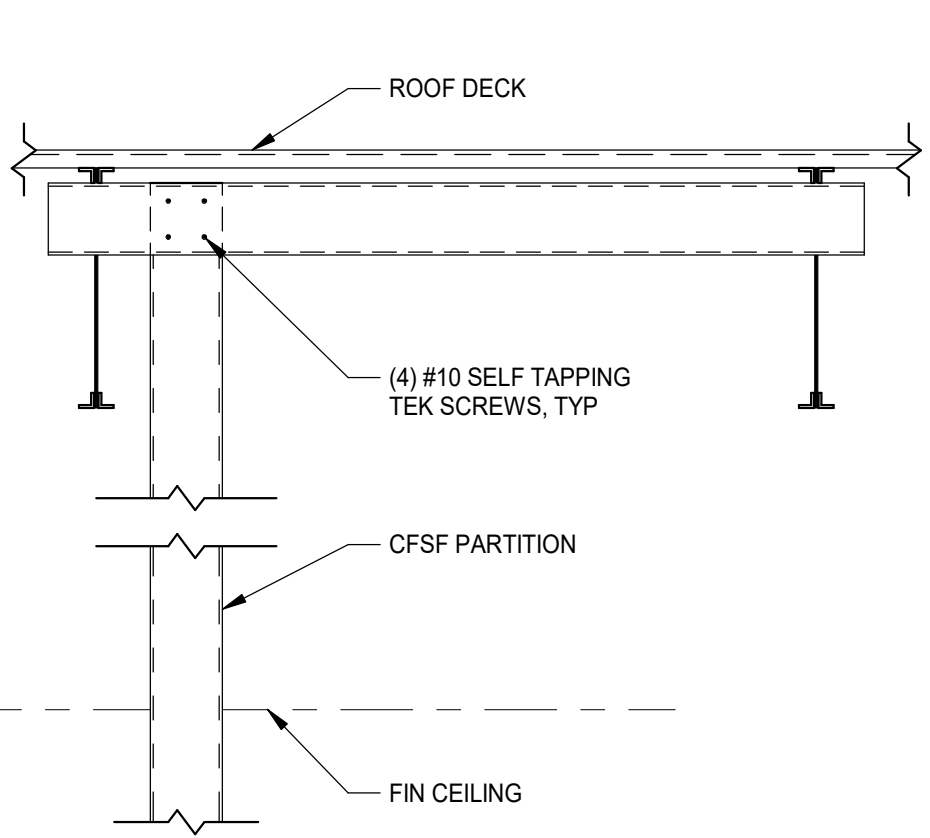
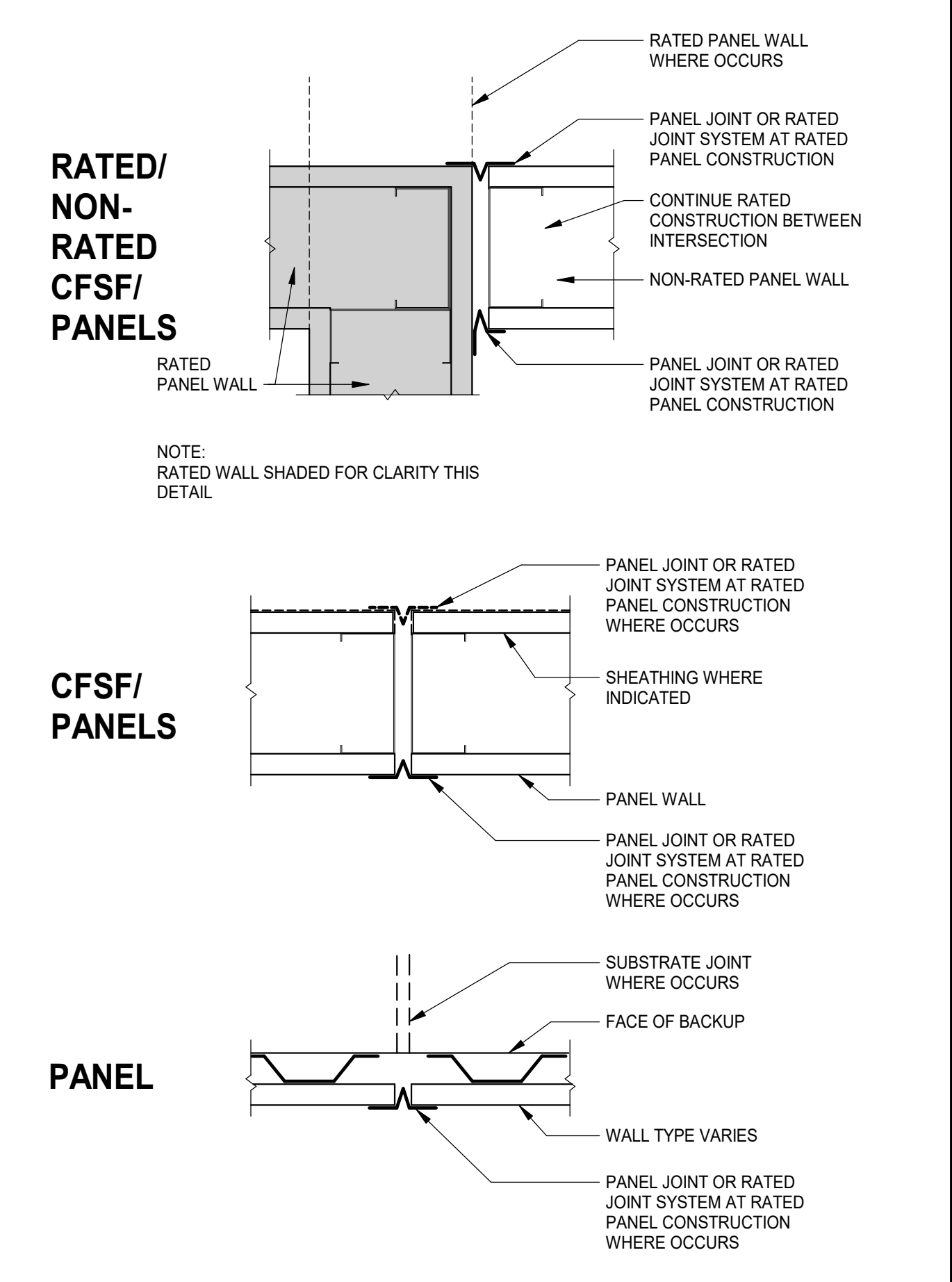

**WALL TO DECK - PARALLEL TO JOISTS**

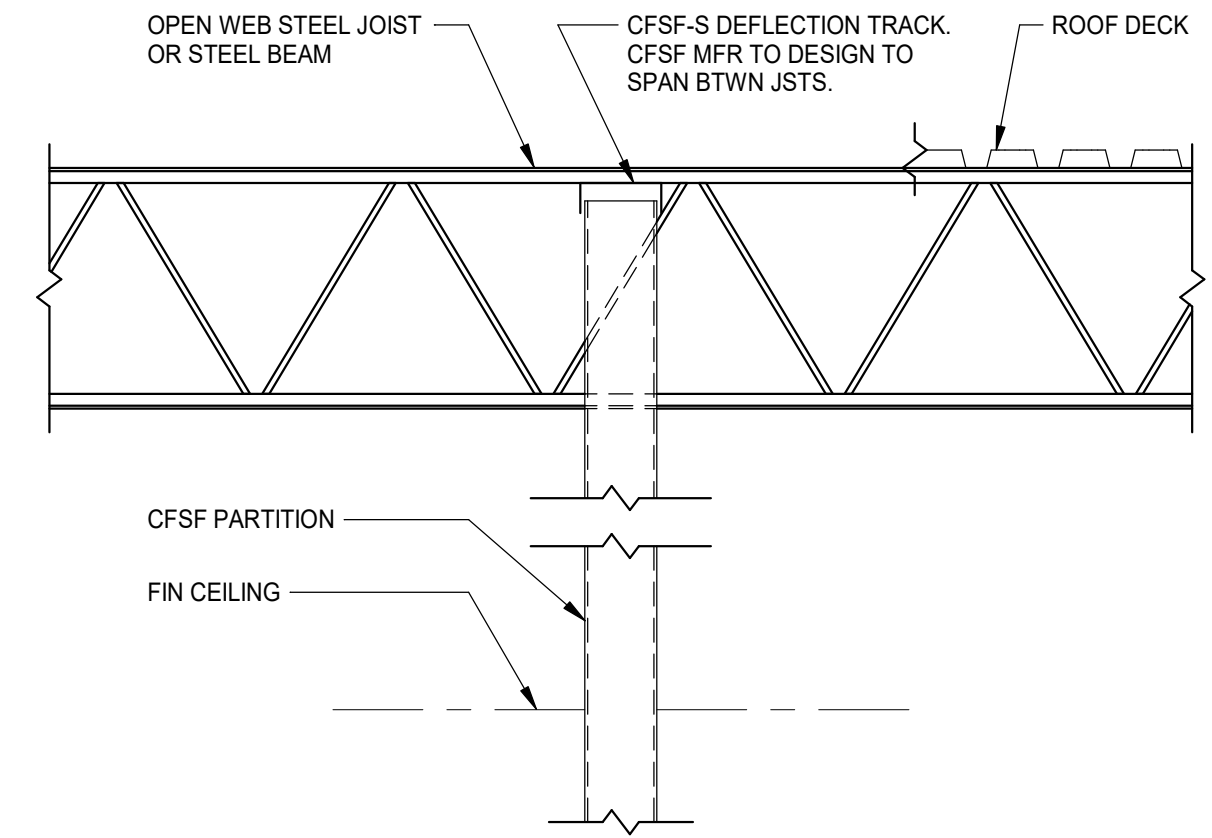

**WALL TO DECK - PERPENDICULAR TO JOISTS**

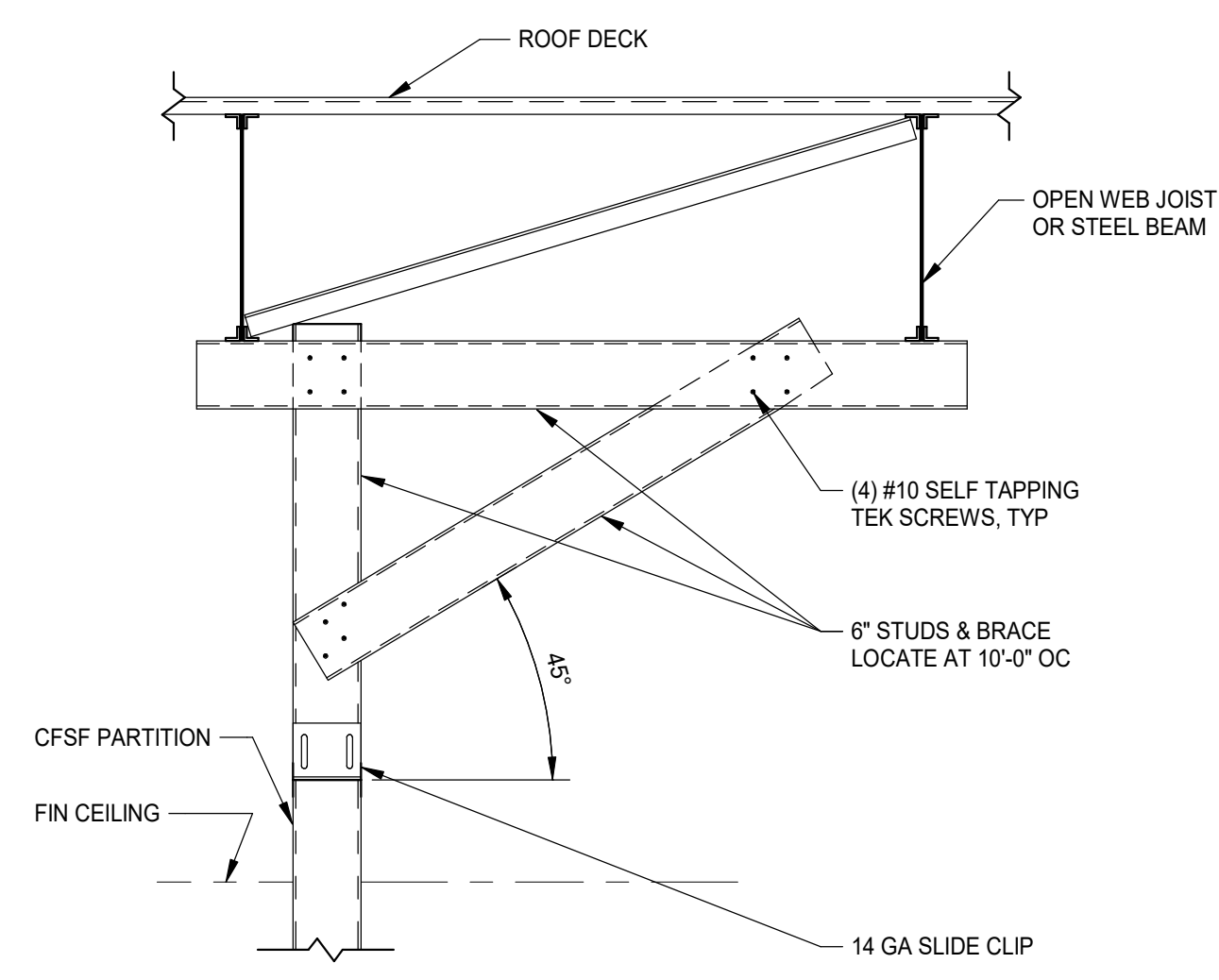

**LOW WALL PARALLEL TO JOISTS**

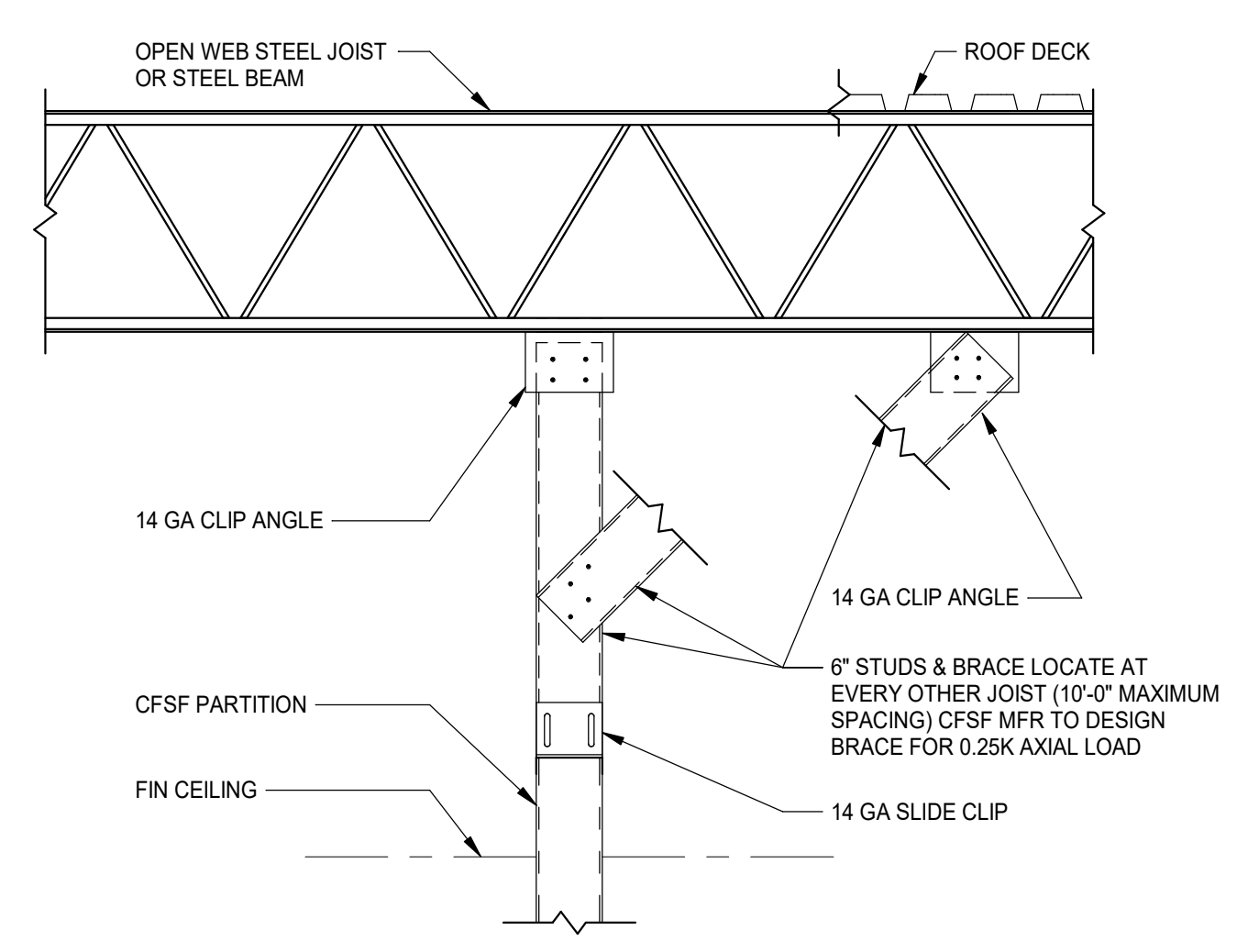

**LOW WALL PERPENDICULAR TO JOISTS**

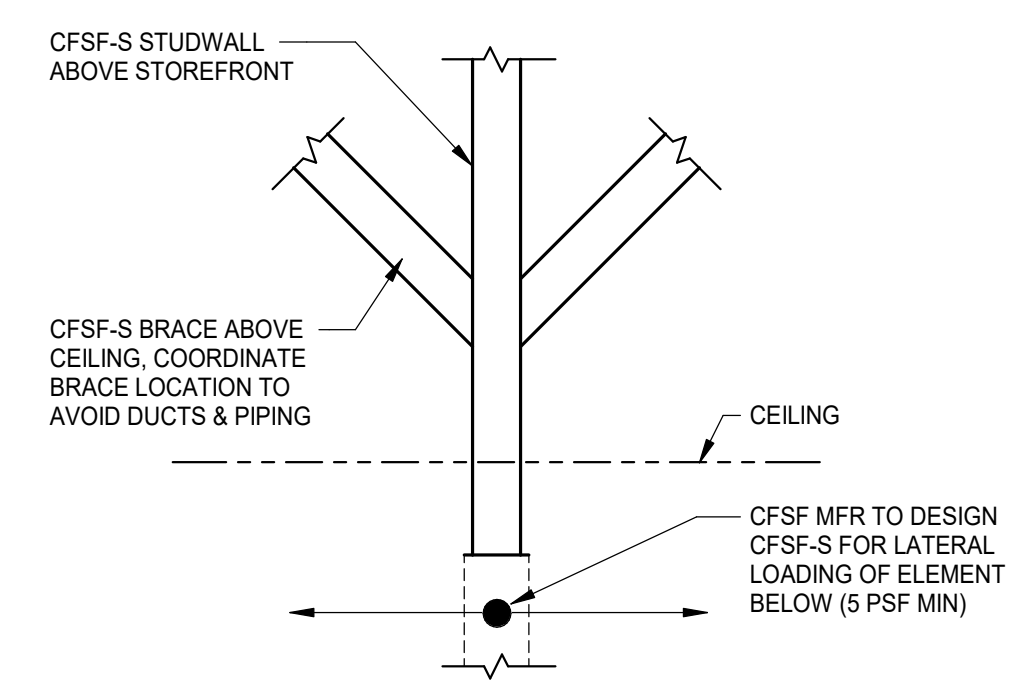

**BRACING AT CFSF-S STUDWALL DETAIL**

- NOTES:
1. BRACE INTERIOR CFSF WALLS THAT DO NOT EXTEND TO DECK IN ACCORDANCE WITH THESE DETAILS UNLESS OTHERWISE INDICATED.
  2. IN LIEU OF BRACING AT TOPS OF WALLS, BRACING MAY BE PROVIDED BY INTERSECTING WALLS WHEN THE DISTANCE BETWEEN THE INTERSECTING WALLS DOES NOT EXCEED 10'-0".
  3. REFER TO ARCHITECTURAL DRAWINGS FOR INTERIOR PARTITION TYPES AND LOCATIONS.
  4. INSTALL BRACING AFTER ALL ROOF DEAD LOAD IS IN PLACE.

**BRACING DETAILS FOR INTERIOR CFSF PARTITIONS**

NO SCALE

NO SCALE

2/9/2024 8:22:07 AM

J  
I  
H  
G  
F  
E  
D  
C  
B  
A

1 2 3 4 5 6 7 8 9 10

 **SECOND FLOOR DEMOLITION PLAN**  
1/4" = 1'-0"

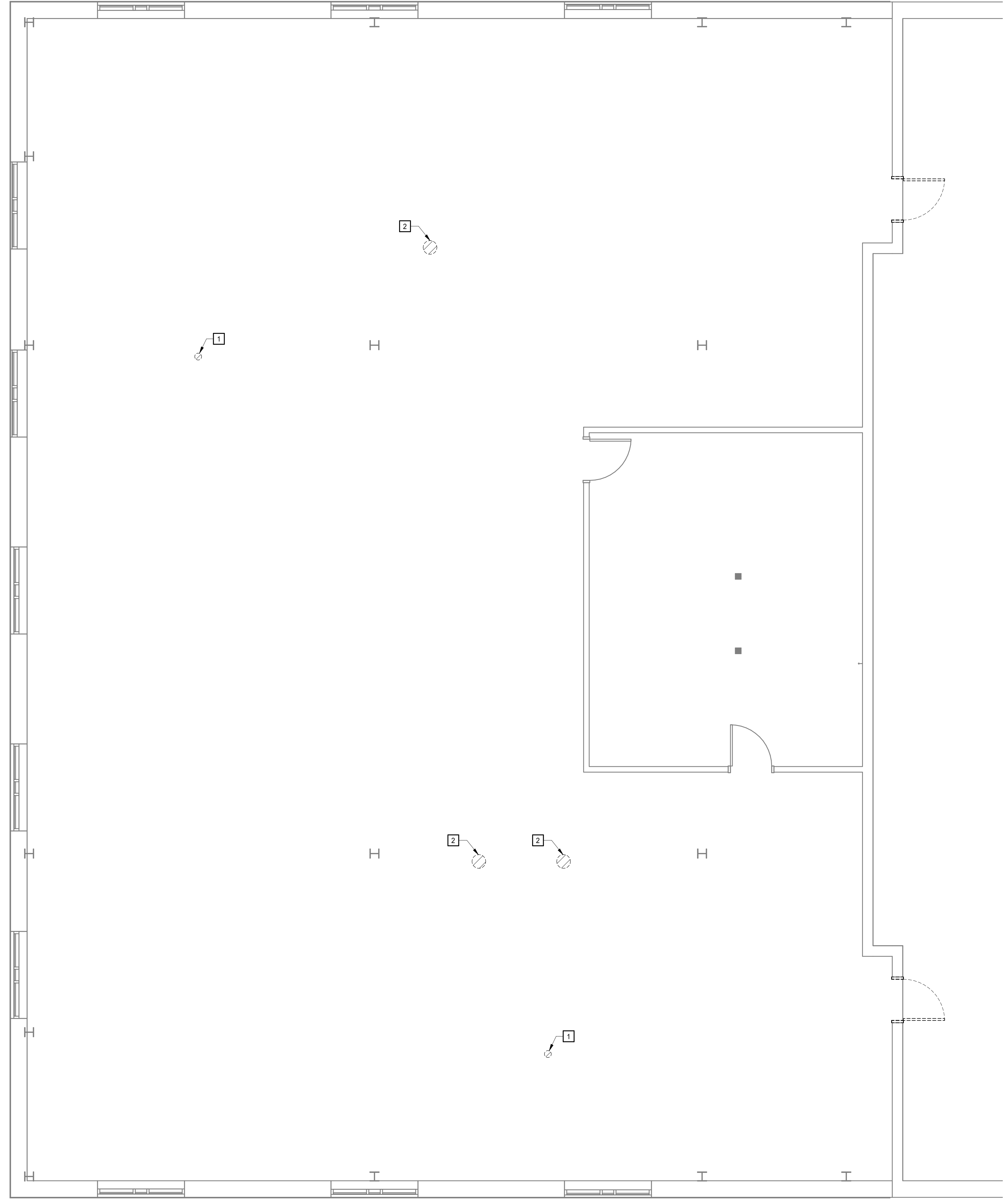

**DEMOLITION PLAN LEGEND**  
APPLIES TO DRAWINGS A1.2.1 - A1.2.n

 EXISTING PARTITION/ WALL/ ITEM TO REMAIN

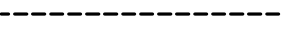
 REMOVE EXISTING PARTITION/WALL/ITEM

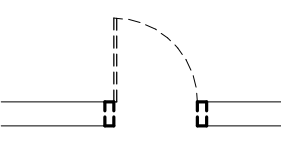
 REMOVE EXISTING DOOR ONLY; FRAME ASSEMBLY, ANCHORS, AND THRESHOLD (WHERE OCCURS) ARE TO REMAIN; DOOR HARDWARE TO BE RETURNED TO OWNER

**DEMOLITION PLAN GENERAL NOTES**

A. REFER TO PLUMBING, MECHANICAL, AND ELECTRICAL DRAWINGS FOR ADDITIONAL INFORMATION.

**DEMOLITION PLAN KEYNOTES**  
REPRESENTED BY 

APPLIES TO DRAWINGS A1.2

1. COORDINATE DEMOLITION WITH PLUMBING SCOPE OF WORK

2. COORDINATE DEMOLITION WITH ELECTRICAL SCOPE OF WORK



**MOSELEYARCHITECTS**

911 N. WEST STREET, SUITE 205 RALEIGH, NORTH CAROLINA 27603  
PHONE (919) 840-0091  
MOSELEYARCHITECTS.COM

**HARNETT CO DSS UPFIT 2ND FLOOR**

631797  
**HARNETT CO DSS**  
311 W CORNELIUS HARNETT BLVD, LILLINGTON, NC 27546

PROJECT NO:	631797
DATE:	FEBRUARY 7, 2024
REVISIONS	
DATE	DESCRIPTION



DEMOLITION PLAN

**A1.2**

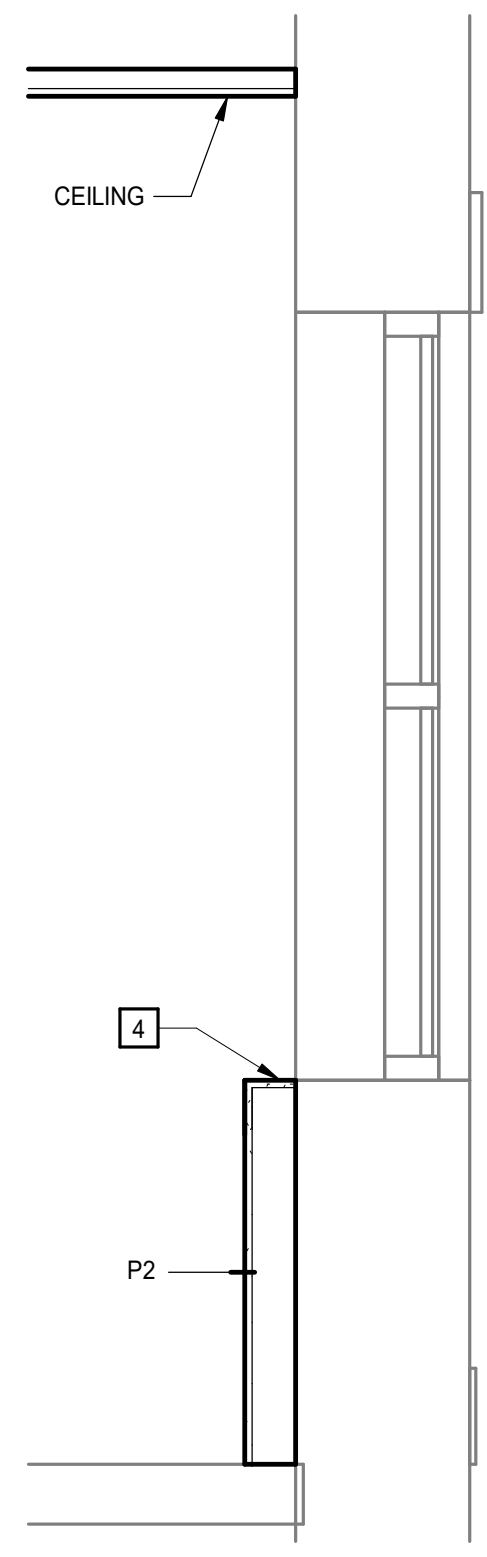
J  
H  
G  
F  
E  
D  
C  
B  
A

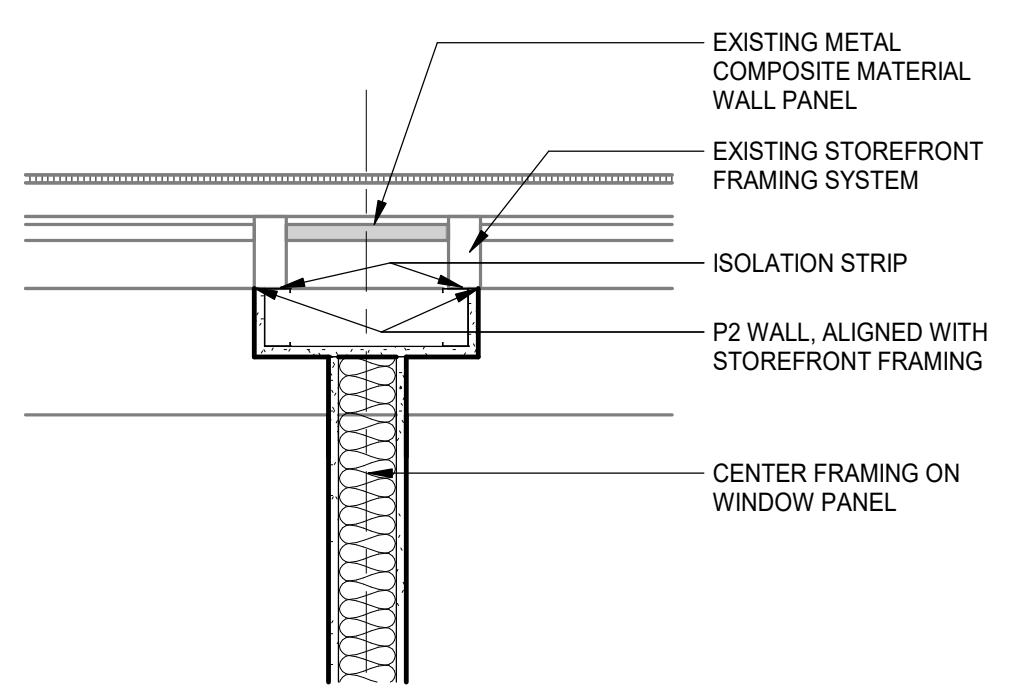

**4 WALL SECTION**  
A2.1/A2.1 3/4" = 1'-0"



**3 PLAN DETAIL**  
A2.1/A2.1 1" = 1'-0"

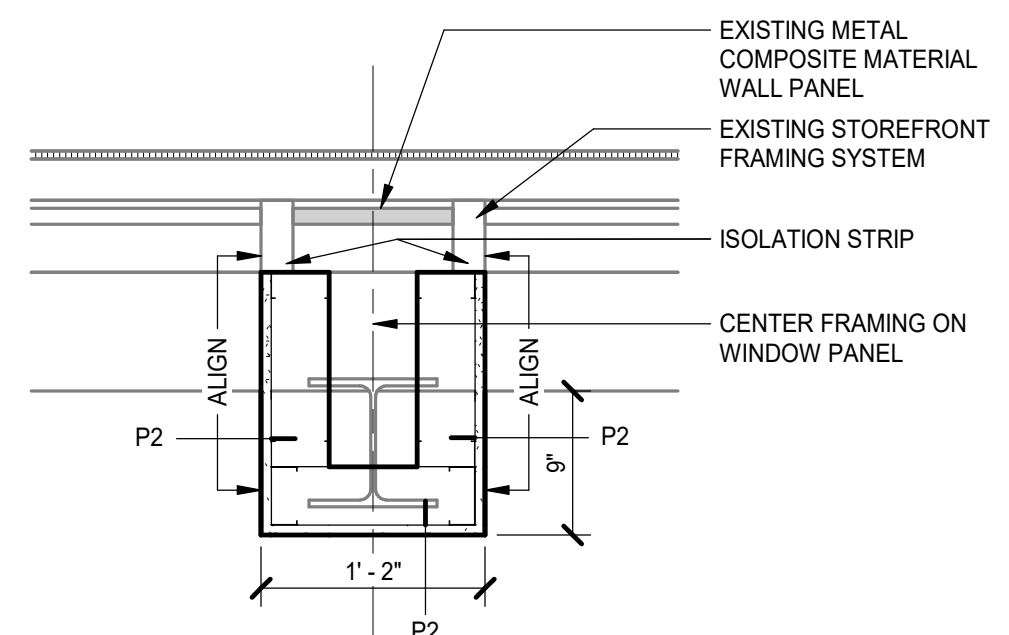

**2 PLAN DETAIL**  
A2.1/A2.1 1" = 1'-0"

**SECOND FLOOR PLAN**  
1/4" = 1'-0"

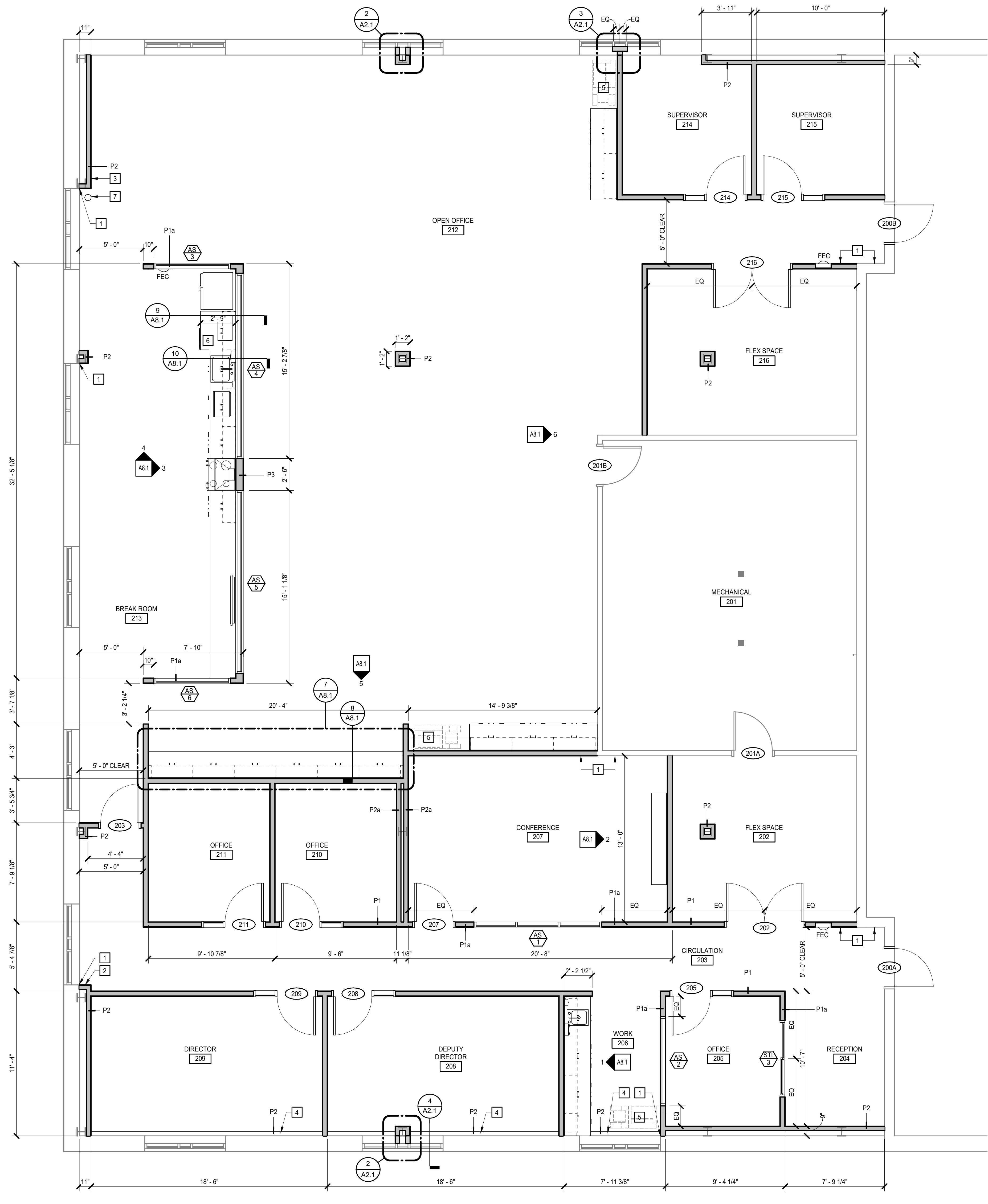

- FLOOR PLAN GENERAL NOTES**
- A. VERIFY IN FIELD ALL P2 WALL LOCATIONS AND ENSURE WALLS ARE TIGHT TO EXISTING STRUCTURE.
  - B. VERIFY IN FIELD ALL WALL LOCATIONS THAT ALIGN TO AN EXISTING WALL AND/OR WINDOW CONDITION. COORDINATE WITH ARCHITECT IF THERE ARE DISCREPANCIES WITH EXISTING CONDITIONS OR DIMENSIONS SHOWN.
  - C. VERIFY IN FIELD ALL WALL LOCATIONS THAT ARE TO CONCEAL AN EXISTING PIPE OR SIMILAR CONDITION. COORDINATE WITH ARCHITECT IF THERE ARE DISCREPANCIES AND/OR ADJUSTMENTS NEEDED.
  - D. COORDINATE THE WORK OF ALL TRADES. VERIFY LOCATIONS AND EXTENT OF INSERTS, ANCHORS, PENETRATIONS, ETC., REQUIRED BY PLUMBING, MECHANICAL, AND ELECTRICAL TRADES.
  - E. PATCH, REPAIR AND PAINT ALL EXISTING GYP BD SURFACES TO CREATE A SEAMLESS TRANSITION AND UNIFORM APPEARANCE.
  - F. SIGNAGE: GC SHALL PROVIDE AND INSTALL SIGNAGE. ALL ROOMS TO MATCH EXISTING, TYPICAL.

- FLOOR PLAN KEYNOTES**  
REPRESENTED BY [N]  
APPLIES TO DRAWINGS A2.1
- 1. ALIGN TO EXISTING WALL AND/OR JAMB CONDITION
  - 2. FRAME TIGHT AROUND EXISTING PIPE AT BASE OF WINDOW AND FOLLOW PIPE ANGLE TO MINIMIZE OVERLAP OF WINDOW. PROVIDE ACCESS PANEL. REFER TO IMAGE A FOR REFERENCE
  - 3. FRAMING TO CONCEAL EXISTING PIPE. PROVIDE ACCESS PANEL. REFER TO IMAGE B FOR REFERENCE
  - 4. P2 LOW WALL AT EXTERIOR WALL. RETURN GYP AT TOP OF WALL AND ALIGN TO EXISTING WINDOW SILL. PATCH AND CONCEAL JOINT. REFER TO 4/A2.1
  - 5. PRINTER / COPIER, NIC - OWNER FURNISHED, OWNER INSTALLED
  - 6. 33" DEEP COUNTERTOP ABOVE ICE MAKER AND DRAWERS. REFER TO ELEVATION
  - 7. LEVEL AND FILL EXISTING PIPE CAVITY IN PREPARATION FOR FLOORING. REFER TO IMAGE B FOR REFERENCE



IMAGE A



IMAGE B



PROJECT NO:	631797
DATE:	FEBRUARY 7, 2024
REVISIONS	
DATE	DESCRIPTION

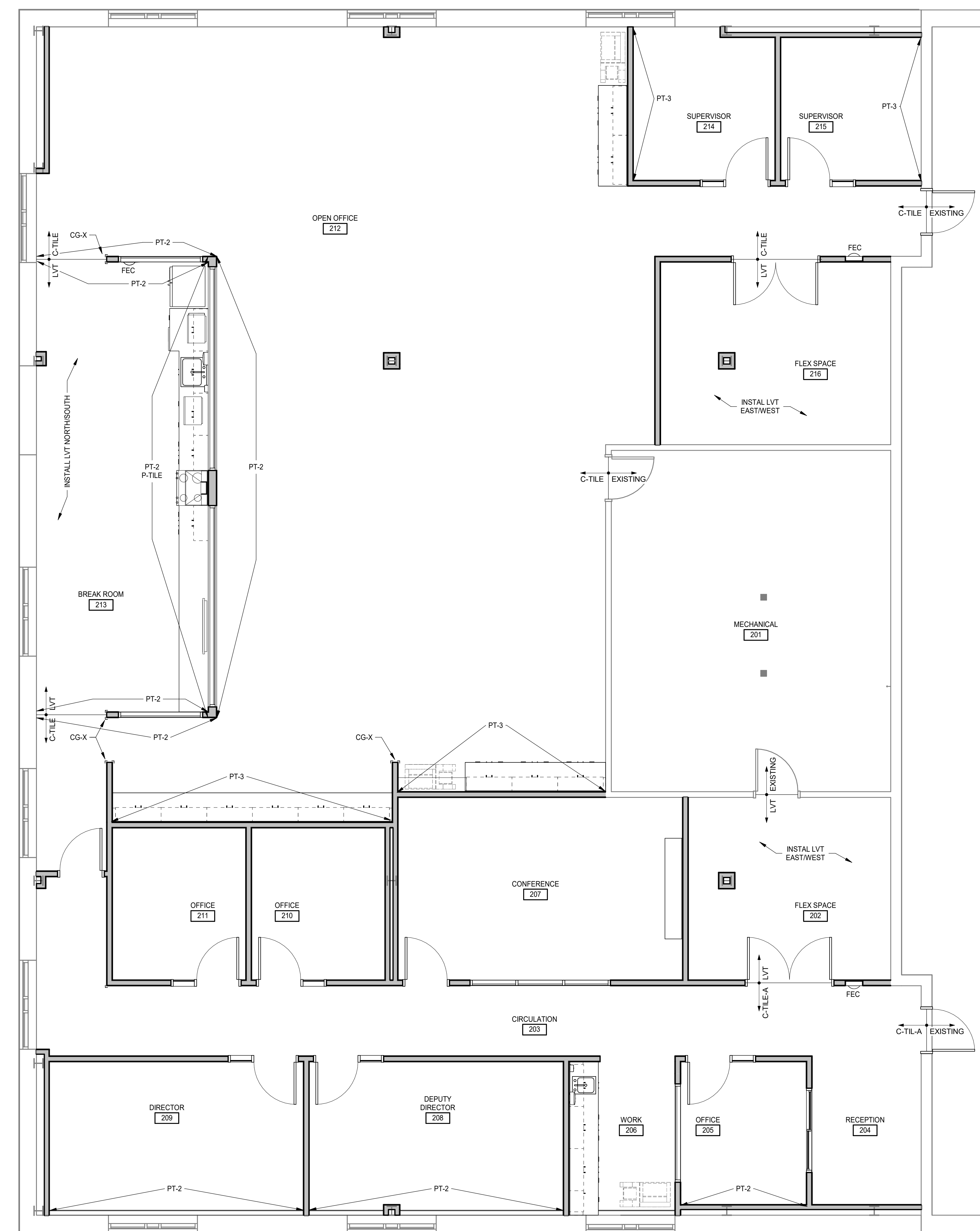

NUMBER	NAME	FLOOR	BASE	WALLS					CEILING	NOTES
				NORTH	EAST	SOUTH	WEST	EXISTING		
201	MECHANICAL	EXISTING	EXISTING	EXISTING	EXISTING	EXISTING	EXISTING	EXISTING		
202	FLEX SPACE	LVT	RB	PT	PT	PT	PT	ACP		
203	CIRCULATION	C-TILE	RB	PT	PT	PT	PT	ACP		
204	RECEPTION	C-TILE	RB	PT	PT	PT	PT	ACP		
205	OFFICE	C-TILE	RB	PT	PT	PT	PT	ACP		
206	WORK	C-TILE	RB	PT	PT	PT	PT	ACP		
207	CONFERENCE	C-TILE	RB	PT	PT	PT	PT	ACP		
208	DEPUTY DIRECTOR	C-TILE	RB	PT	PT	PT	PT	ACP		
209	DIRECTOR	C-TILE	RB	PT	PT	PT	PT	ACP		
210	OFFICE	C-TILE	RB	PT	PT	PT	PT	ACP		
211	OFFICE	C-TILE	RB	PT	PT	PT	PT	ACP		
212	OPEN OFFICE	C-TILE	RB	PT	PT	PT	PT	ACP		
213	BREAK ROOM	LVT	RB	PT	PT	PT	PT	ACP		
214	SUPERVISOR	C-TILE	RB	PT	PT	PT	PT	ACP		
215	SUPERVISOR	C-TILE	RB	PT	PT	PT	PT	ACP		
216	FLEX SPACE	LVT	RB	PT	PT	PT	PT	ACP		

**FINISH SCHEDULE GENERAL NOTES**

A. FINISH SCHEDULE DESCRIBES ONLY THE BASIC OR PREDOMINANT SURFACE FINISH.

B. PROVIDE SAME FINISHES AS THE ADJACENT SPACE IN ALCOVES AND CONTINUOUS SPACES WITHOUT DESIGNATED SPACE NUMBERS.

C. CASEWORK FINISHES ARE NOT NOTED IN THE FINISH SCHEDULE. REFER TO BASIS OF DESIGN AND SPECIFICATIONS FOR MATERIALS AND FINISHES.

D. DIRECTIONAL WALL FINISH INDICATORS (NORTH, EAST, SOUTH, WEST) REFER TO THE "PLAN" NORTH ORIENTATION.

E. BULKHEADS AND SOFFITS MAY NOT BE INDICATED IN FINISH SCHEDULE, REFER TO RCP DETAILS, AND OTHER DOCUMENTS FOR EXTENT.

F. PROVIDE CONTINUOUS SEALANT BETWEEN INTERIOR SLAB-ON-GRADE AND VERTICAL ELEMENT WHERE JOINT IS NOT CONCEALED BY FINISH BASE OR OTHER CONSTRUCTION

**FINISH PLAN GENERAL NOTES**

A. REFER TO A0.1 FOR ABBREVIATION LEGEND.

B. WHERE ONE FINISH IS LISTED ON ALL WALLS OF THE ROOM, THE FINISH PLANS DO NOT SHOW EXTENT OF FINISH. FINISH PLANS AND ELEVATIONS SHOW EXTENT OF MATERIALS WHERE FINISH SCHEDULE LISTS MULTIPLE FINISHES IN ONE ROOM.

C. DIRECTIONAL WALL FINISH INDICATORS (NORTH, SOUTH, EAST, WEST) REFER TO THE "PLAN" NORTH ORIENTATION.

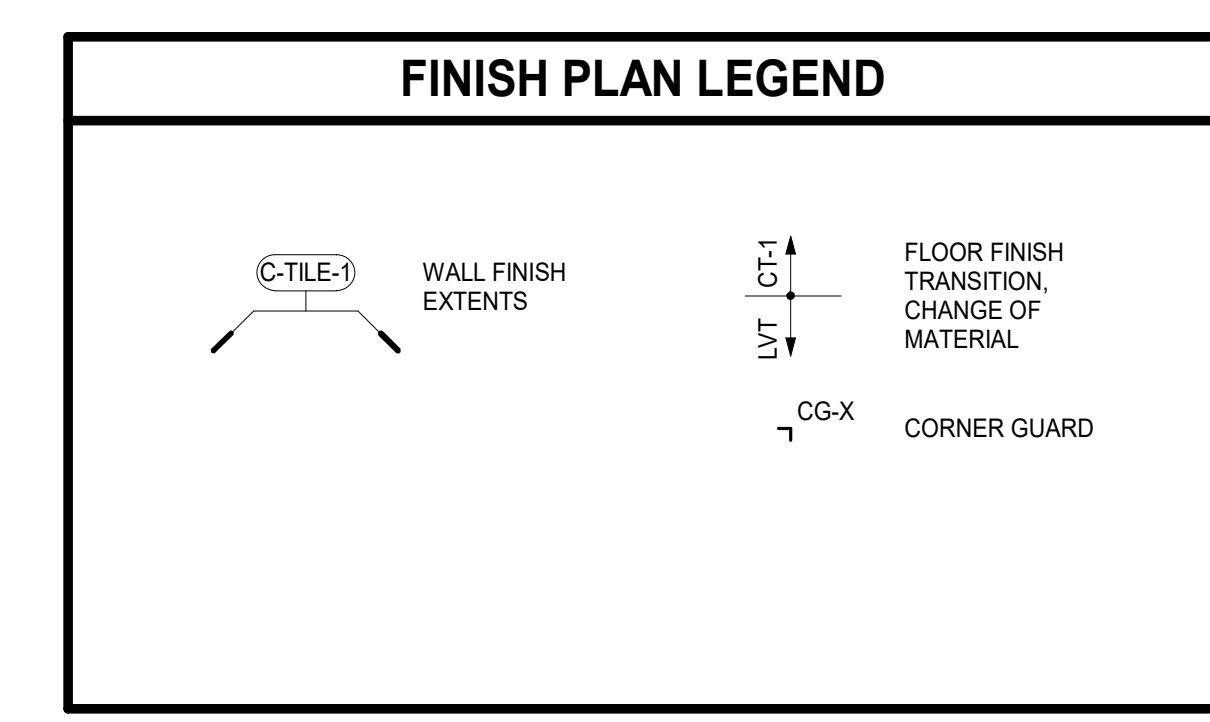

**INTERIOR FINISH LEGEND - BASIS OF DESIGN**

DESCRIPTION	MATERIAL	MANUFACTURER	PRODUCT - COLOR
M1	TRANSITION STRIP	SCHLUTER SYSTEMS	RENO-TK - STAINLESS STEEL
M2	THRESHOLD	SCHLUTER SYSTEMS	RENO-T1 STAINLESS STEEL
M3	EDGE TRIM	SCHLUTER SYSTEMS	SCHIENE - STAINLESS STEEL
M4	HARDWARE PULLS	RICHELIEU	MODERN METAL PULL - 8656; CENTER TO CENTER 5", FINISH TBD
M5	BLINDS		
035300			
P-TILE	CEMENT TILE	TILEBAR	COLOR ONE- OCEAN BLEND-MATTE/GLOSS
64023			
PL-1	PLASTIC LAMINATE	WILSONART	VAPOR STRANDS 4939K-18 LINEARITY FINISH
95100			
ACP	ACOUSTICAL CEILING PANELS	ARMSTRONG	MATCH EXISTING
96513			
RB	RUBBER BASE	ROPPE	TBD
096519			
LVT	LUXURY VINYL TILE	EF CONTRACT	STYLE: WOODLANDS, COLOR: IRONWOOD EFCW001
96813			
C-TILE-A	CARPET TILE	BENTLY	PATTERN: REDUX DEUX, COLOR: REKINDLE 403772
99100			
PT-1	PAINT	PPG PAINTS ARENA	PPG 1006-1 GYPSUM
PT-2	ACCENT PAINT	PPG PAINTS ARENA	MATCH PANTONE PMS 556C, HEX #71a28a
PT-3	ACCENT PAINT	PPG PAINTS ARENA	MATCH PANTONE PMS 541C, HEX #003674
123651.16			
SSM	SOLID SURFACE	FORMICA	ASHEN CONCRETE 607

**SECOND FLOOR FINISH PLAN**  
 1/4" = 1'-0"

**HARNETT CO DSS UPFIT 2ND FLOOR**

631797  
 HARNETT CO DSS  
 311 W CORNELIUS HARNETT BLVD, LILLINGTON, NC 27546

PROJECT NO:	631797
DATE:	FEBRUARY 7, 2024
REVISIONS	
DATE	DESCRIPTION

FINISH PLAN AND  
 FINISH SCHEDULE

**A3.0.1**



DOOR SCHEDULE													
NUMBER	TYPE	DOOR				FRAME							NOTES
		SIZE (NOMINAL)	MATL	LOUVER	UC	GLAZING TYPE	TYPE	NUMBER	SECTIONS	HEAD DETAIL	JAMB DETAIL	SILL DETAIL	
200A	N	3'-0" x 8'-0" x 1 3/4"	WD	--	--	G1	EX	--	--	EX	EX	5.0	--
200B	N	3'-0" x 8'-0" x 1 3/4"	WD	--	--	G1	EX	--	--	EX	EX	5.0	--
202	F	PR 3'-0" x 8'-0" x 1 3/4"	WD	--	--	G1	EX	--	--	EX	EX	4.0	--
203	N	3'-0" x 8'-0" x 1 3/4"	WD	--	--	G1	EX	--	--	EX	EX	5.0	--
205	F	3'-0" x 8'-0" x 1 3/4"	WD	--	--	STL	2	A	1/A3.1.1	1/A3.1.1	1/A3.1.1	3.0	--
207	FG	3'-0" x 8'-0" x 1 3/4"	WD	--	--	STL	1	A	1/A3.1.1	1/A3.1.1	1/A3.1.1	1.0	--
208	F	3'-0" x 8'-0" x 1 3/4"	WD	--	--	STL	2	A	1/A3.1.1	1/A3.1.1	1/A3.1.1	2.0	--
209	F	3'-0" x 8'-0" x 1 3/4"	WD	--	--	STL	1	A	1/A3.1.1	1/A3.1.1	1/A3.1.1	1.0	--
210	F	3'-0" x 8'-0" x 1 3/4"	WD	--	--	STL	1	A	1/A3.1.1	1/A3.1.1	1/A3.1.1	1.0	--
211	F	3'-0" x 8'-0" x 1 3/4"	WD	--	--	STL	1	A	1/A3.1.1	1/A3.1.1	1/A3.1.1	1.0	--
214	F	3'-0" x 8'-0" x 1 3/4"	WD	--	--	STL	1	A	1/A3.1.1	1/A3.1.1	1/A3.1.1	1.0	--
215	F	3'-0" x 8'-0" x 1 3/4"	WD	--	--	STL	1	A	1/A3.1.1	1/A3.1.1	1/A3.1.1	1.0	--
216	F	PR 3'-0" x 8'-0" x 1 3/4"	WD	--	--	STL	2	A	1/A3.1.1	1/A3.1.1	1/A3.1.1	4.0	--

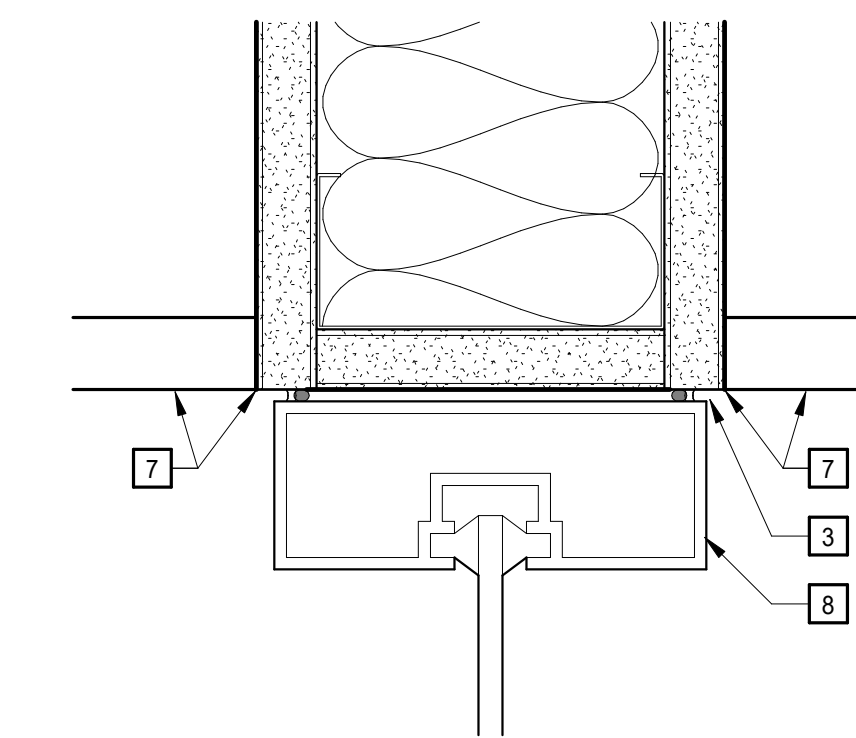

**3 HEAD DETAIL**  
A3.1.1 | A3.1.1 | 6" = 1'-0"

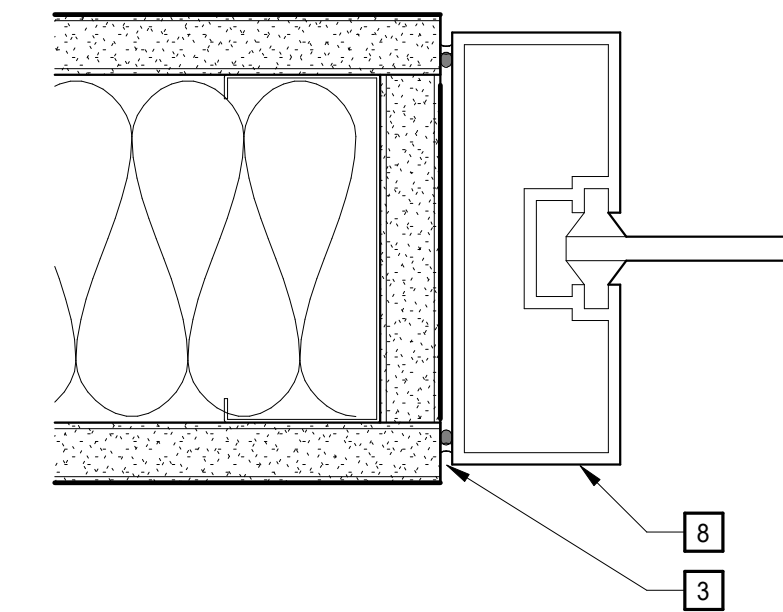

**2 HEAD, JAMB, SILL DETAIL**  
A3.1.1 | A3.1.1 | 6" = 1'-0"

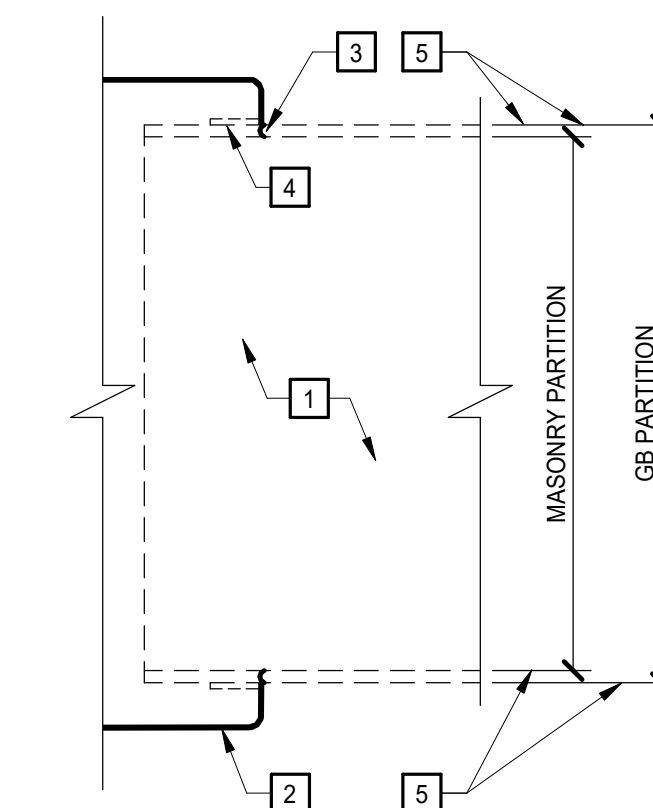

**1 HEAD AND JAMB DETAIL**  
A3.1.1 | A3.1.1 | 6" = 1'-0"

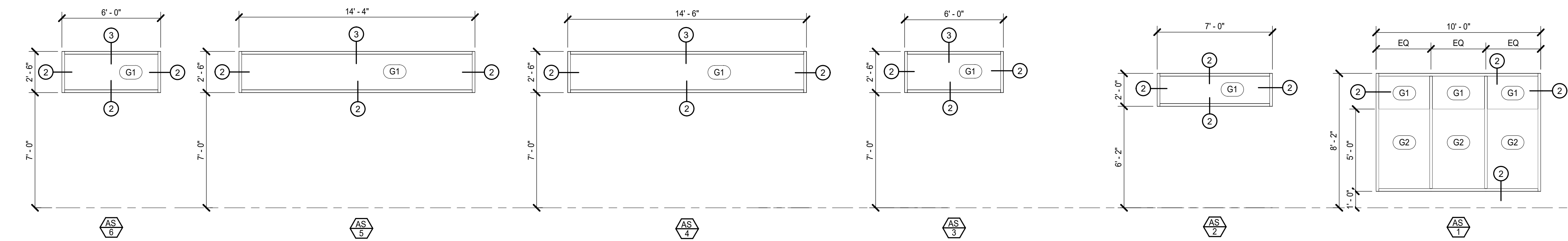

**ALUMINUM STOREFRONT TYPES**

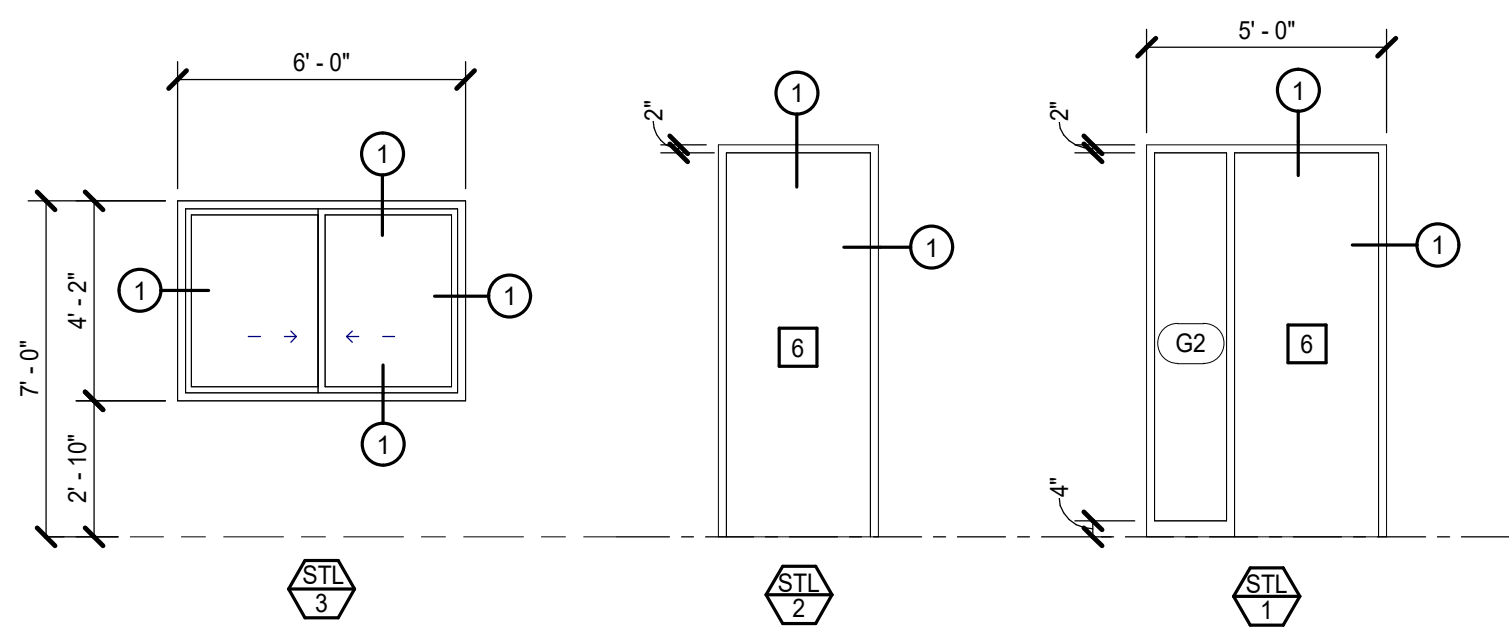

**STEEL FRAME TYPES**

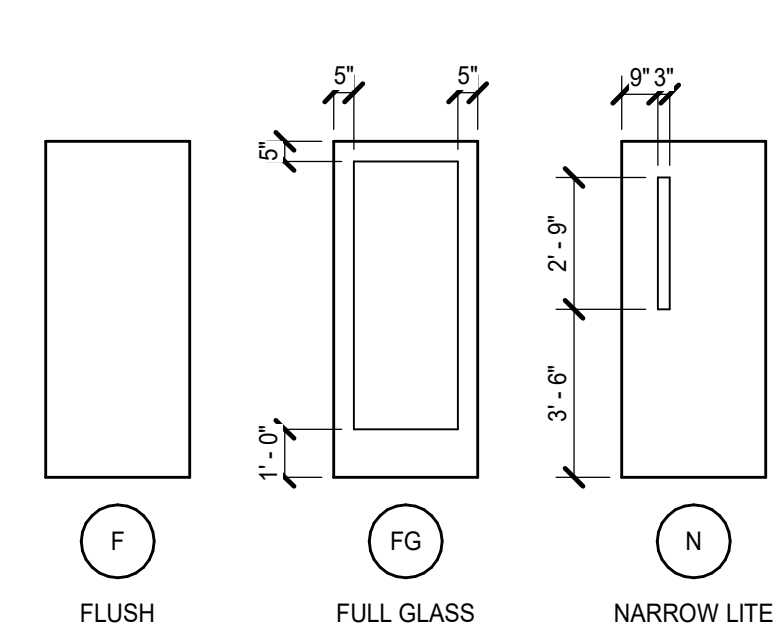

**DOOR PANEL TYPES**

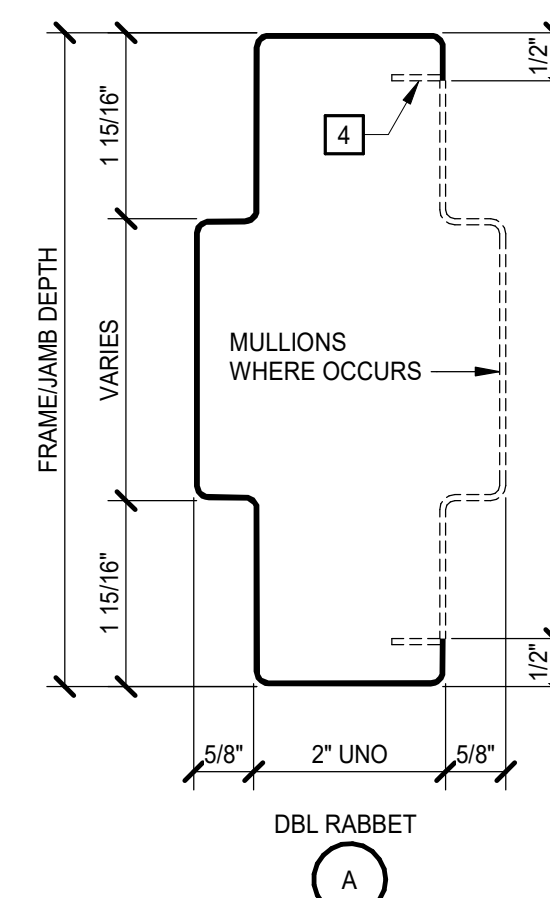

**STEEL FRAME SECTIONS**  
NO SCALE

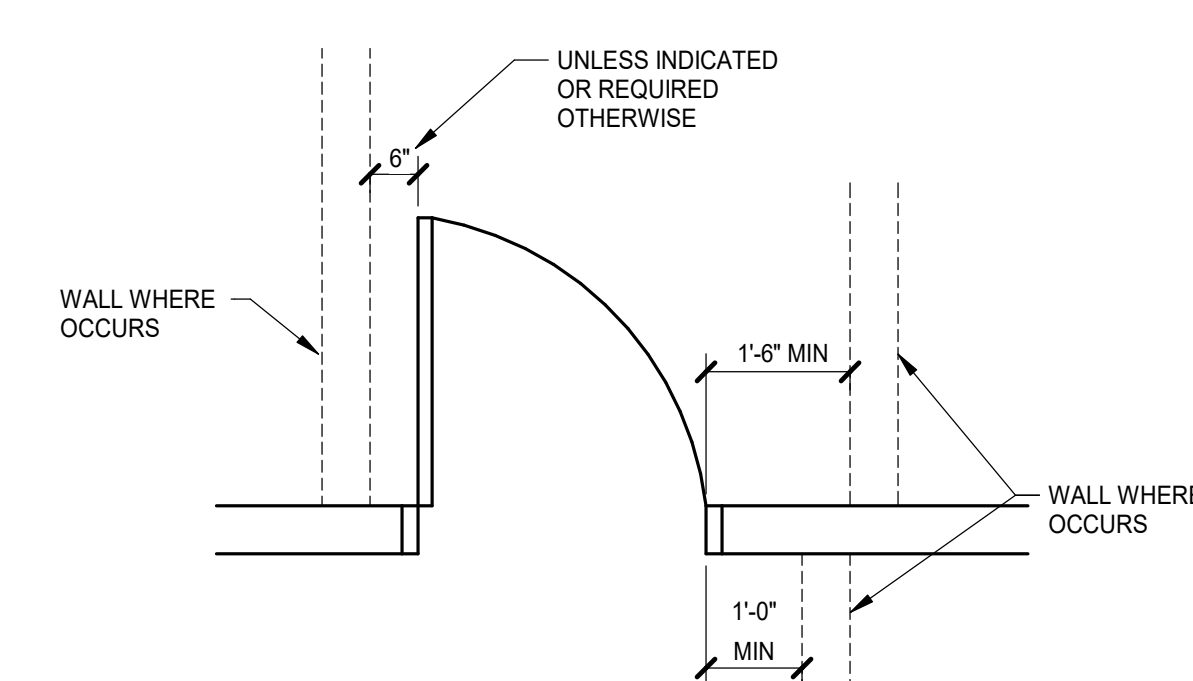

**MANEUVERING CLEARANCE AT DOORS**  
NO SCALE

**GENERAL NOTES**

REFER TO DWG A3.1.1 FOR GLAZING TYPE LEGEND AND NOTES

REFER TO DWG A3.1.1 FOR DETAILS

REFER TO DWG A3.1.1 FOR KEYNOTE LEGEND

A. UNLESS INDICATED OTHERWISE, ALL DETAIL NUMBERS IN THE DOOR AND FRAME SCHEDULE FOR HEAD, JAMB AND SILL CONDITIONS REFER TO DRAWINGS A3.1.1.

B. DOOR AND FRAME DETAILS INDICATE GENERAL CHARACTERISTICS OF DOOR AND FRAME SIZES AND COMPONENTS AND MAY NOT INDICATE EXACT FIELD CONDITIONS OR REQUIREMENTS. COORDINATE DETAILS WITH OTHER DRAWINGS AND SPECS TO DETERMINE ALL COMPONENTS (E.G., SEALANTS, ANCHORS, HARDWARE, LINTELS, CLIPS) REQUIRED FOR COMPLETE AND FUNCTIONAL INSTALLATION.

C. DOOR SWINGS ON FLOOR PLANS TAKE PRECEDENCE OVER SWINGS INDICATED ELSEWHERE (E.G., ELEVATIONS).

**GLAZING TYPES**  
REPRESENTED BY (n)

1. 1/4" CLEAR  
2. 1/4" CLEAR WITH APPLIED PRIVACY FILM

**NOTES:**  
1. ALL GLAZING IN INTERIOR FRAMES SHALL BE TYPE 1, UNLESS SPECIFICALLY INDICATED OTHERWISE.  
2. GLAZE ALL OPENINGS IN FRAMES UNLESS SPECIFICALLY INDICATED OTHERWISE.  
3. ALL GLAZING SHALL BE SAFETY GLASS UNLESS INDICATED OTHERWISE.

**DOOR AND FRAME DETAIL KEYNOTES**  
REPRESENTED BY (n)

APPLIES TO DRAWINGS A3.1.1

1. ANCHORAGES, REINFORCING, SPECIFIC PARTITION CONSTRUCTION AND/OR LINTELS ARE NOT SHOWN FOR CLARITY.  
2. REFER TO FRAME SECTION IN DOOR SCHEDULE FOR TYPE.  
3. SEALANT, ALL SIDES - TOOL TO 90°.  
4. BACKBEND RETURN @ GB LOCATIONS ONLY.  
5. 0" @ GB LOCATIONS; 1/16" @ MAS LOCATIONS.  
6. SIZE AS REQUIRED TO ACCOMMODATE DOOR, HARDWARE, AND FRAME COMPONENTS.  
7. ADJACENT CEILING, ALIGNED.  
8. STOREFRONT FRAMING AND GLAZING.



PROJECT NO:	631797
DATE:	FEBRUARY 7, 2024
REVISIONS	
DATE	DESCRIPTION



PROJECT NO:	631797
DATE:	FEBRUARY 7, 2024
REVISIONS	
DATE	DESCRIPTION

CASEWORK GENERAL NOTES

- A. UNLESS INDICATED OTHERWISE, ALL COUNTERTOP(S):
- 2'-10" AFF MAX OR 2'-10" MAX
  - 2'-0" DEEP
  - SOLID SURFACE WITH UNDERMOUNT SINK AT BREAK RM
  - BACKSPASHES: 4" HIGH AT ALL SIDES AND BACK
  - EXTEND COUNTERTOP 1/2" PAST BASE CABINET AT ALL EXPOSED CASEWORK ENDS
  - VERIFY SLAB LEVELNESS AT CASEWORK PRIOR TO INSTALL. CONSTRUCTION TOLERANCES DO NOT APPLY TO ACCESSIBILITY DIMENSIONS; MAX DIMENSIONS SHALL BE MAINTAINED.
- B. UNLESS INDICATED OTHERWISE, ALL BASE CABINET(S):
- 2'-0" DEEP NOMINAL
  - TOE KICKS: 4" NOMINAL HIGH (REDUCE AS NEEDED FOR TOLERANCES) AND 3" DEEP
  - SINK LOCATIONS: 3'-0" WIDE CLEAR KNEE SPACE, BASE CABINET DOORS TO HAVE INTEGRAL TOE KICK FOR BARRIER FREE ACCESS
- C. UNLESS INDICATED OTHERWISE, ALL WALL CABINET(S):
- 1'-0 1/2" DEEP NOMINAL
  - 2'-0" HIGH
  - TOP AT 7'-0" AFF
  - MINIMUM 11" CLEAR INTERIOR DEPTH
- D. BUILT-IN EQUIPMENT: SIZE OPENING (HEIGHT, WIDTH, AND DEPTH) AND ROUGH-IN REQUIREMENTS AS REQUIRED BASED ON APPROVED MANUFACTURER SUBMITTED.
- E. ALL SHELVES: ADJUSTABLE UNLESS INDICATED OTHERWISE.
- F. PROVIDE FINISH END PANELS AT ALL EXPOSED CASEWORK ENDS.

CASEWORK KEYNOTES

REPRESENTED BY [ ]  
APPLIES TO DRAWINGS A8.1

- WALL MOUNTED TV AND TV BRACKET, PROVIDE BLOCKING IN WALL, REFER TO DIVISION 1 SECTION ALLOWANCES
- TRANSOM WINDOW
- ADA SINK CABINET, DOORS TO HAVE INTEGRAL TOE KICK
- 15'D COUNTER W/ BACKSPASH AND BASE CABINETS
- PLASTIC LAMINATE OPEN SHELF INSTALLED W/ CONCEALED BRACKETS
- SOLID SURFACE COUNTERTOP WITH 4" BACKSPASH AND 2-1/2" DIA GROMMETS CENTERED AT EACH SEAT
- UNDER COUNTER BRACKET SUPPORT, PAINT TO MATCH WALL FINISH
- PRINTER / COPIER, NIC - OWNER FURNISHED, OWNER INSTALLED
- REFRIGERATOR, REFER TO DIVISION 1 SECTION ALLOWANCES
- ICE MAKER, BOD, MANITOWOC UFR200, REFER TO DIVISION 1 SECTION ALLOWANCES
- COFFEE MAKER, REFER TO DIVISION 1 SECTION ALLOWANCES
- MICROWAVE, REFER TO DIVISION 1 SECTION ALLOWANCES
- DROP IN RANGE
- RANGE HOOD
- PULL OUT TRASH
- PULL OUT RECYCLING
- BENCH W/ ELECTRICAL OUTLETS IN BASE INCLUDED IN FURNITURE PACKAGE
- PAPER TOWEL DISPENSER, MOUNT AT 3'-8" AFF TO DISPENSING OUTLET OR OPERABLE PART IF PRESENT (e.g., CRANK, BUTTON, SENSOR)
- SOAP DISPENSER, MOUNT AT 3'-4" AFF TO DISPENSING OUTLET
- UNDER CABINET LIGHTING FOR ALL UPPER CABINETS AT THIS LOCATION
- M3 TILE EDGE TRIM

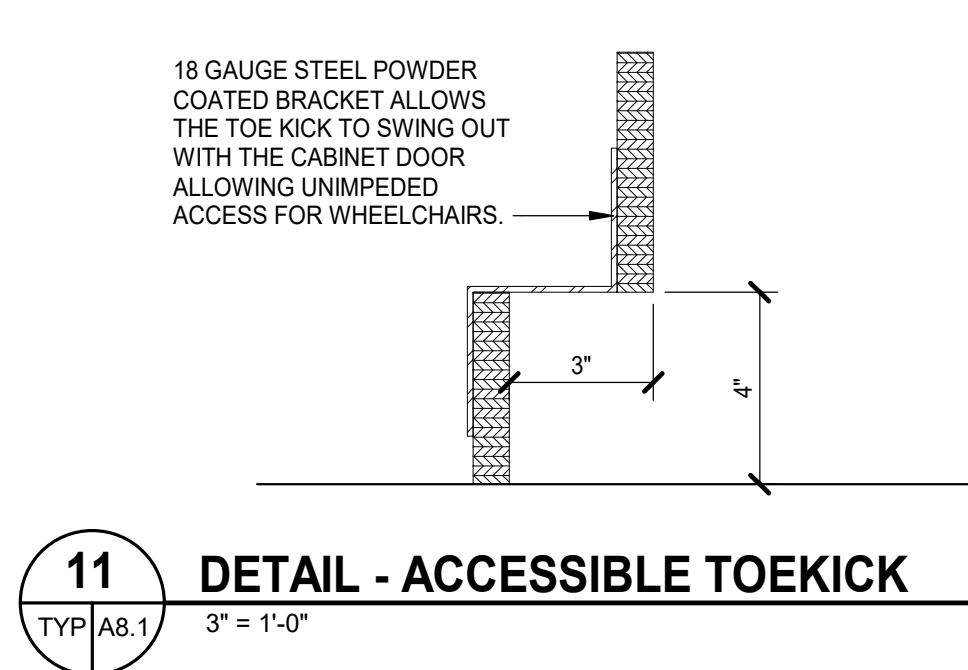

11 DETAIL - ACCESSIBLE TOEKICK  
3" = 1'-0"

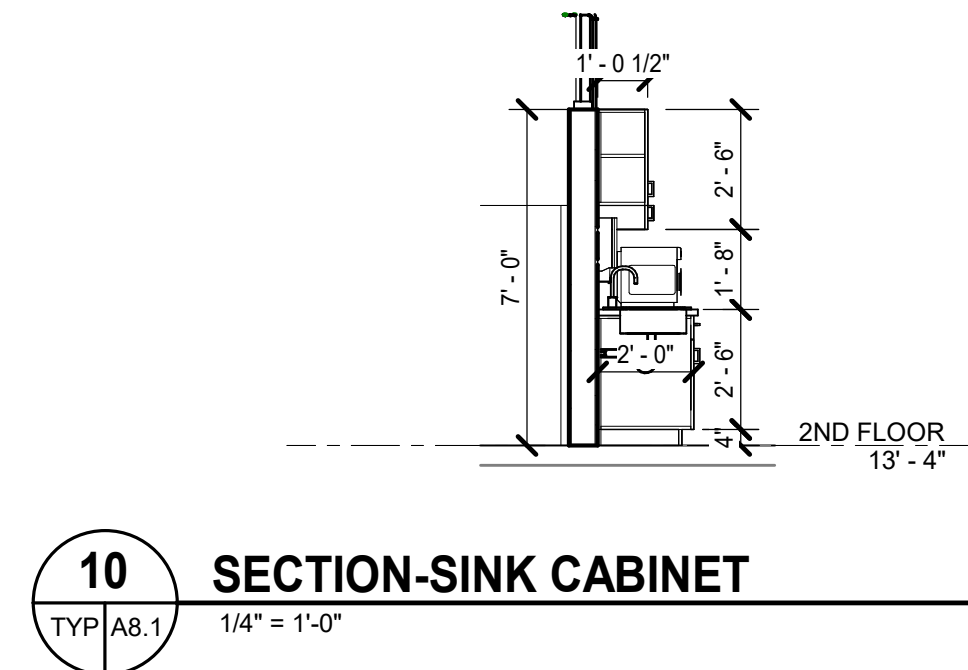

10 SECTION-SINK CABINET  
1/4" = 1'-0"

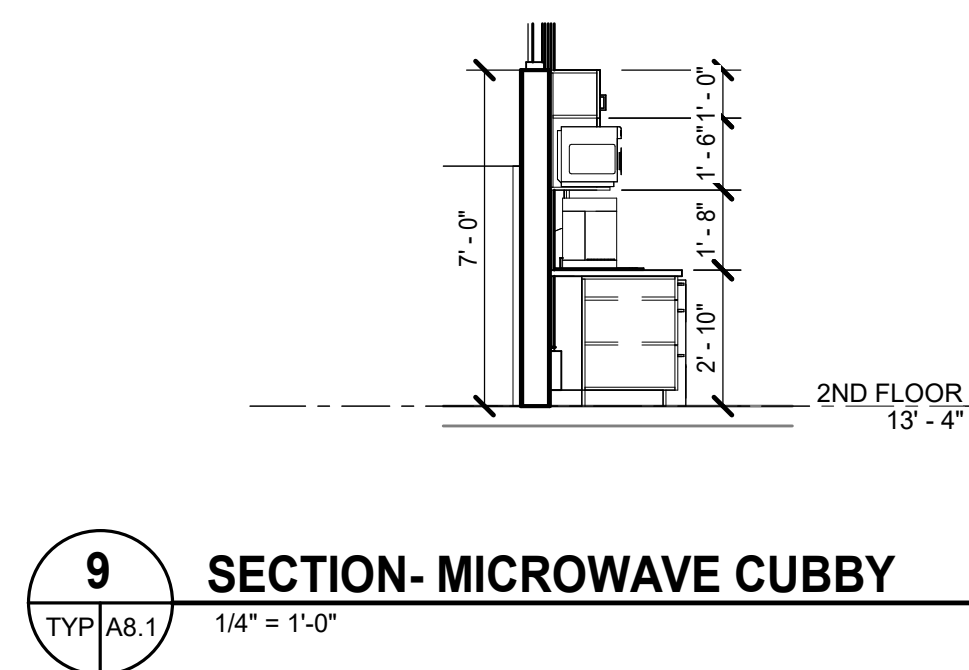

9 SECTION- MICROWAVE CUBBY  
1/4" = 1'-0"

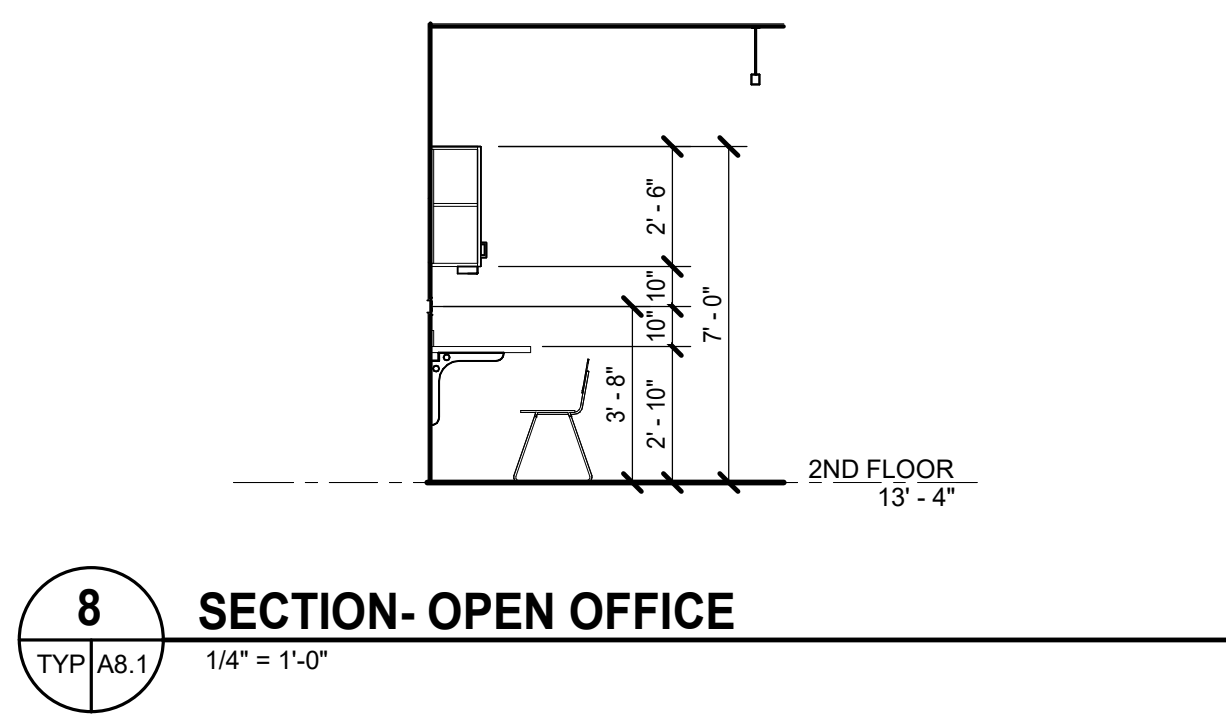

8 SECTION- OPEN OFFICE  
1/4" = 1'-0"

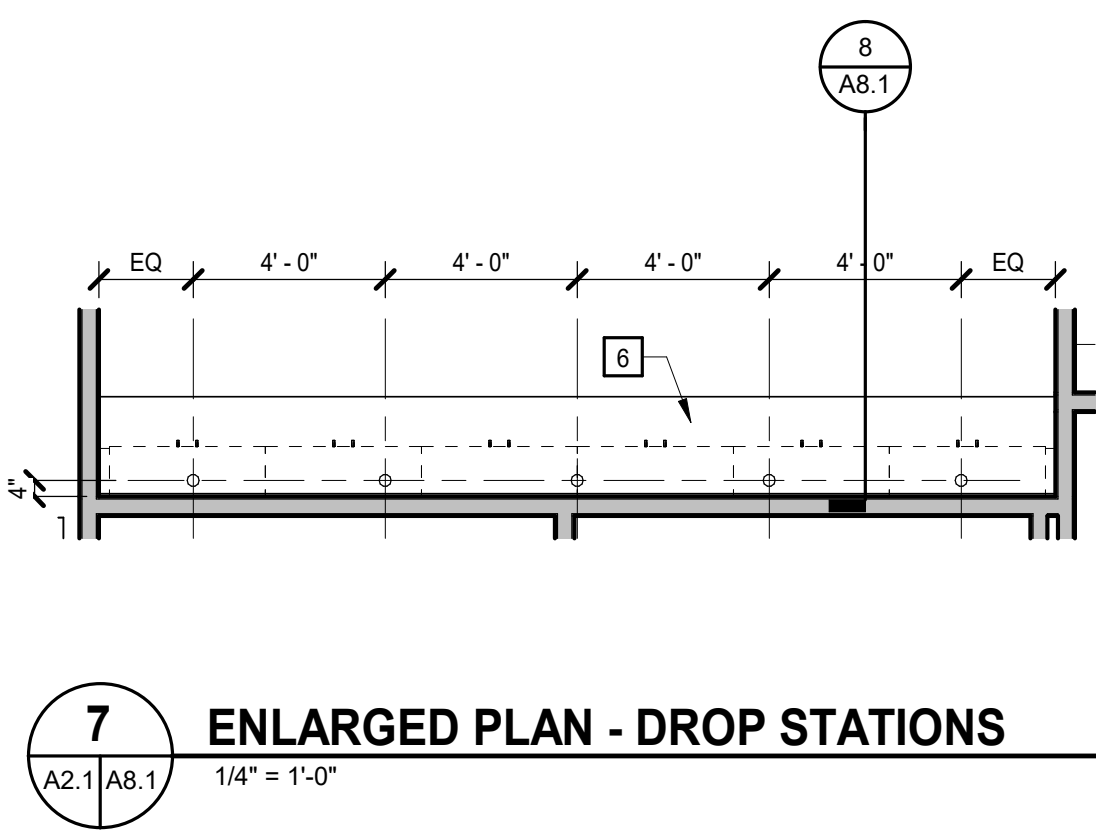

7 ENLARGED PLAN - DROP STATIONS  
1/4" = 1'-0"

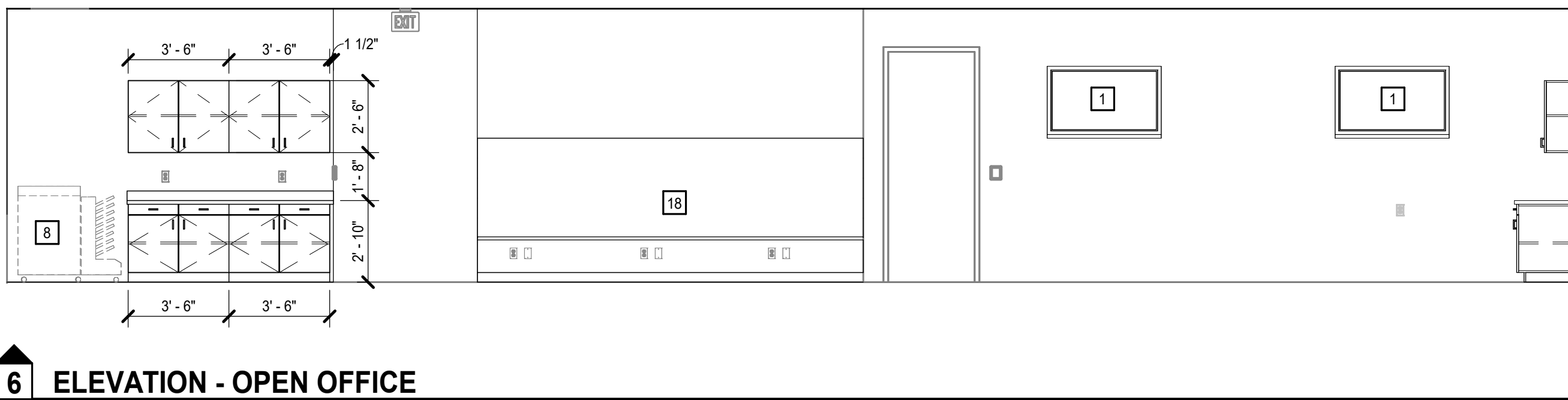

6 ELEVATION - OPEN OFFICE  
1/4" = 1'-0"

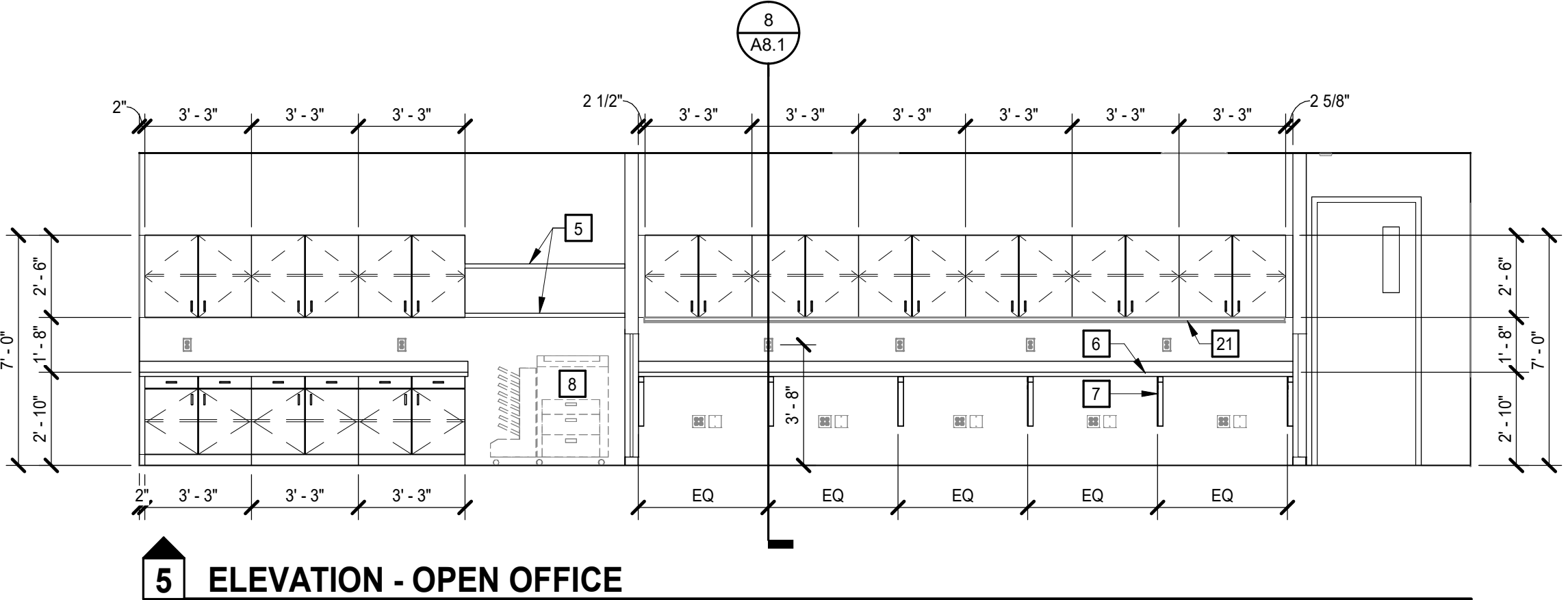

5 ELEVATION - OPEN OFFICE  
1/4" = 1'-0"

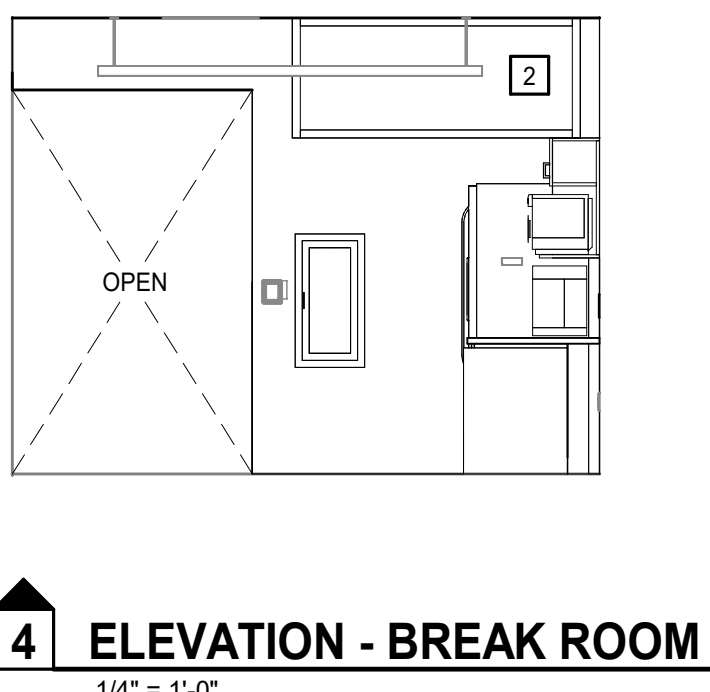

4 ELEVATION - BREAK ROOM  
1/4" = 1'-0"

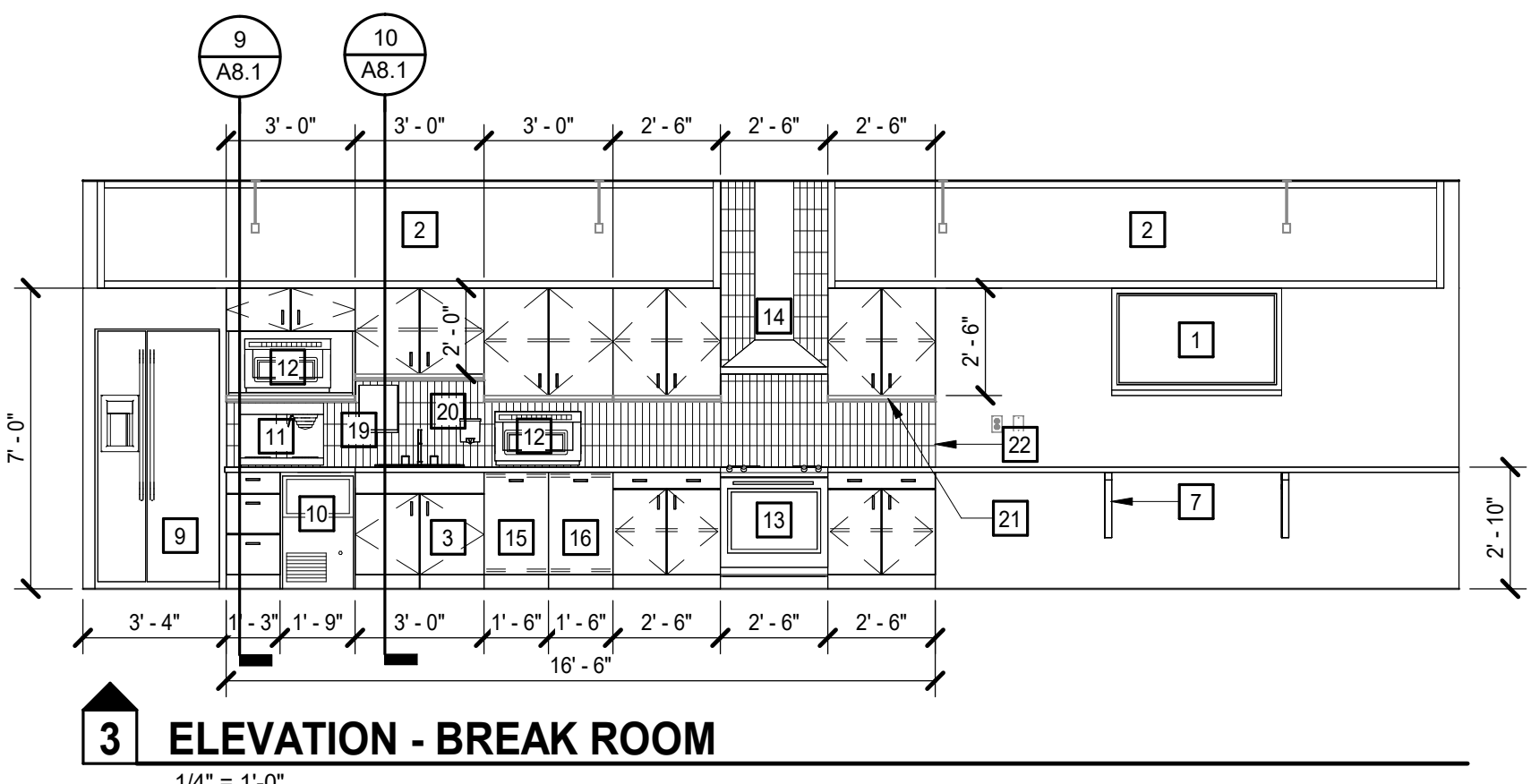

3 ELEVATION - BREAK ROOM  
1/4" = 1'-0"

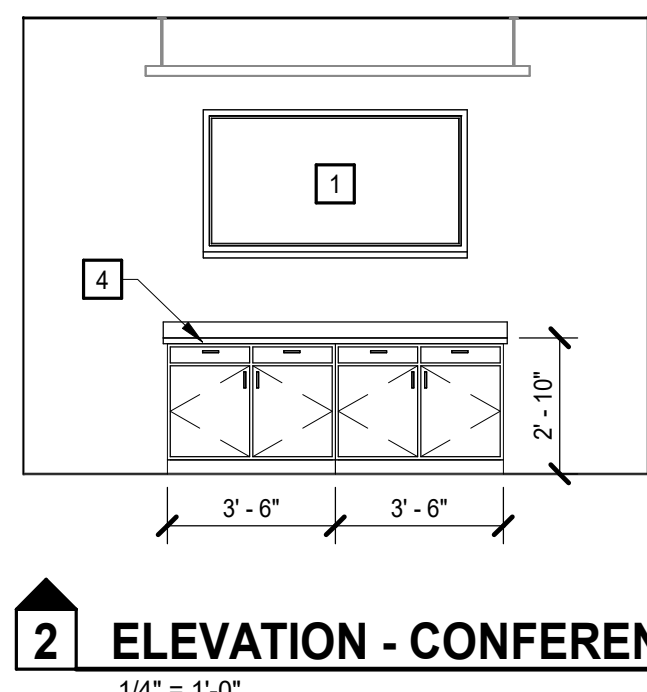

2 ELEVATION - CONFERENCE  
1/4" = 1'-0"

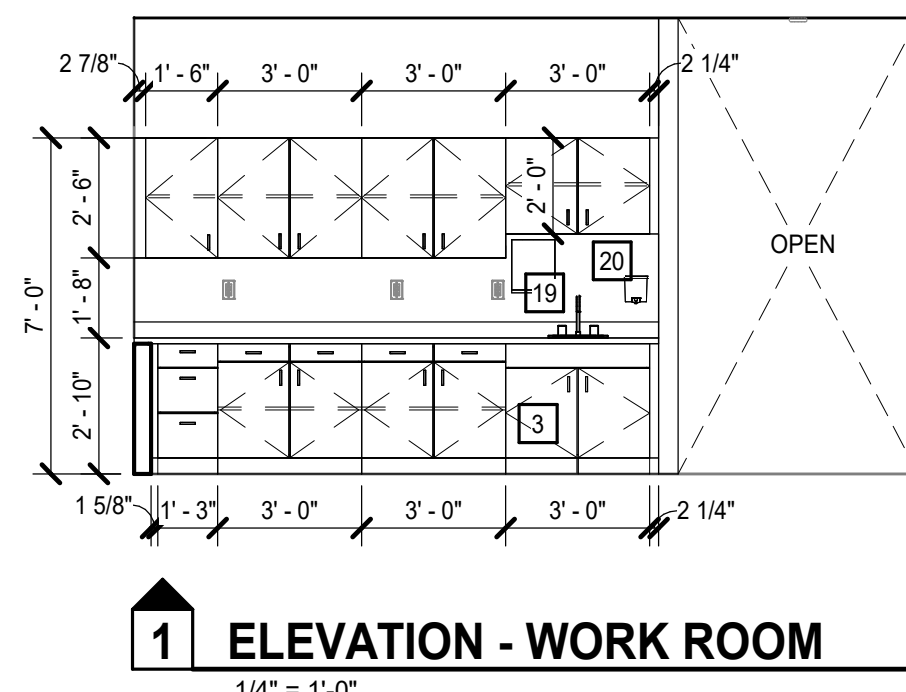

1 ELEVATION - WORK ROOM  
1/4" = 1'-0"

**SECOND FLOOR RCP**  
1/4" = 1'-0"

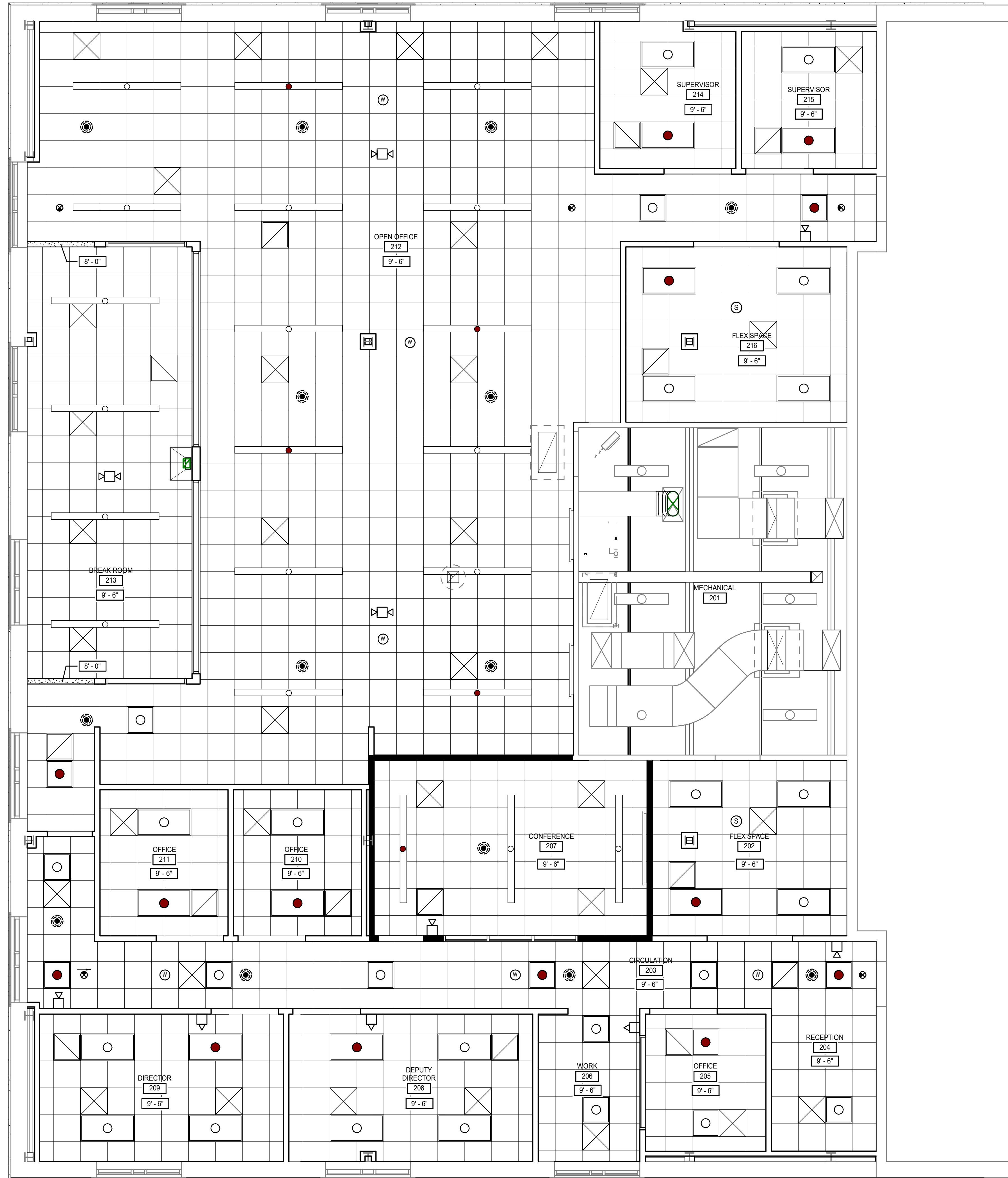

**REFLECTED CEILING PLAN LEGEND**  
APPLIES TO DRAWINGS A9.1

REFER TO M AND E FOR REFLECTED CEILING PLAN SYMBOLS NOT INDICATED BELOW

OFFICE	SPACE NAME
A101	SPACE NUMBER
9'-6"	CEILING HEIGHT, AFF UNO

2'-0" x 2'-0" LAY-IN ACOUSTICAL CEILING PANELS IN SUSPENDED GRID

WITH OPENING	INTERIOR WALL/PARTITION TO UNDERSIDE OF DECK
WITH OPENING	INTERIOR WALL/PARTITION TO CAP ABOVE OR TERMINATES ADJACENT TO A RATED HORIZONTAL ASSEMBLY
WITH OPENING	INTERIOR WALL/PARTITION 4" MIN ABOVE HIGHEST ADJACENT CEILING. IF NECESSARY TO ACHIEVE RESULTS DESIRED, EXTEND WALL HEIGHT SO WALL BRACING IS NOT EXPOSED TO VIEW IN FINISHED SPACES
	EXISTING TO REMAIN. VERIFY VERTICAL EXTENTS WHERE THE HEIGHT IMPACTS THE WORK

**REFLECTED CEILING PLAN/DETAIL GENERAL NOTES**

- ALL CEILING HEIGHTS SHALL BE 9'-6" AFF UNLESS INDICATED OTHERWISE.
- DRAWINGS INDICATE GRID LAYOUT DIAGMATICALLY. REFER TO SPECIFICATIONS FOR SPECIFIC GRID LAYOUT CRITERIA AT PERIMETER CONDITIONS THAT MAY DIFFER FROM GRID LAYOUT INDICATED ON DRAWINGS.
- CENTER CEILING MOUNTED ITEMS WITHIN CEILING PANELS, UNLESS INDICATED OTHERWISE.
- CENTER AND/OR ALIGN SUSPENDED LIGHTING FIXTURE WITH CEILING PANELS, UNLESS INDICATED OTHERWISE.
- PROVIDE METAL BLINDS AT ALL EXTERIOR WINDOW LOCATIONS, MATCH TO LEVEL 1.

**REFLECTED CEILING PLAN KEYNOTES**  
REPRESENTED BY [ ]  
APPLIES TO DRAWINGS A9.1

- CF8F-S
- 5/8" GYP BD, TERMINATE 4" ABV FIN CLG
- FIN CLG, FINISH AND/OR HEIGHT AFF VARIES
- GYP BD, EXTEND FULL HEIGHT, UNLESS INDICATED OTHERWISE

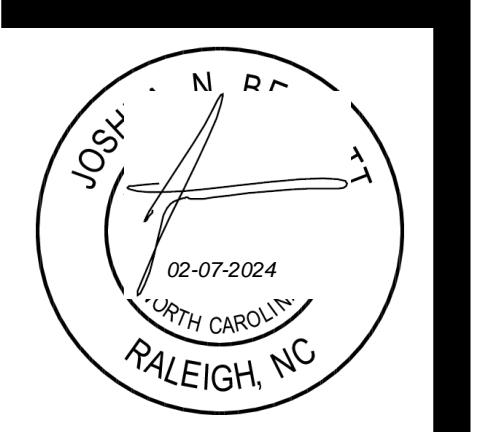
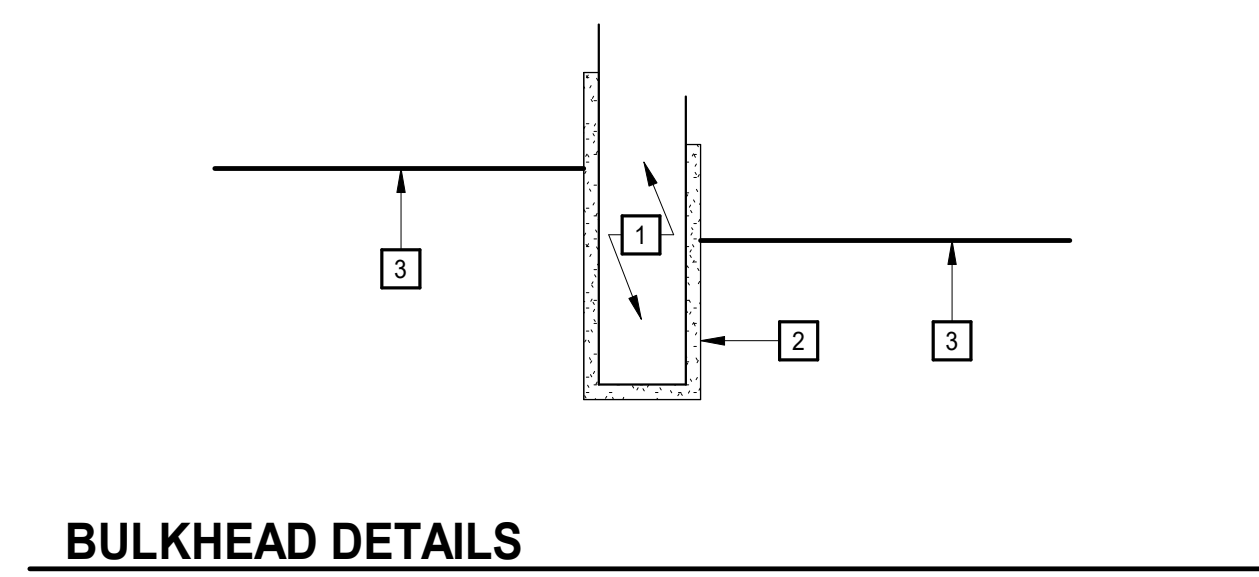

PROJECT NO:	631797
DATE:	FEBRUARY 7, 2024
REVISIONS	
DATE	DESCRIPTION

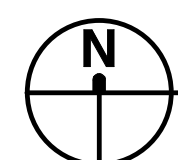

SECOND FLOOR FURNITURE PLAN

1/4" = 1'-0"

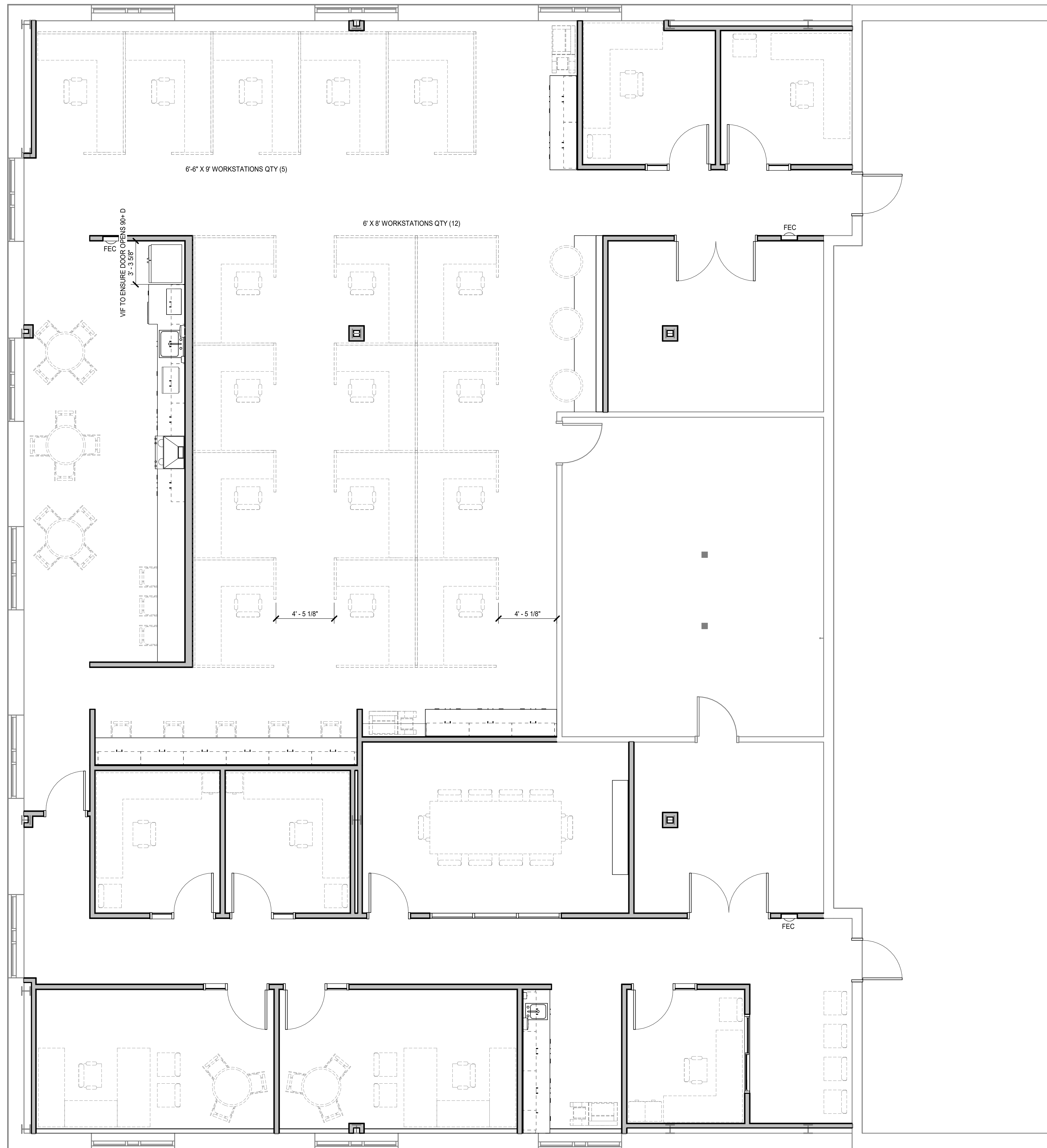

PROJECT NO:	631797
DATE:	FEBRUARY 7, 2024
REVISIONS	
DATE	DESCRIPTION

FURNITURE PLAN

HARNETT CO DSS UPFIT 2ND FLOOR

631797

HARNETT CO DSS

311 W CORNELIUS HARNETT BLVD, LILLINGTON, NC 27546



**GENERAL NOTES**

- A. THE CONTRACT DOCUMENTS ARE COMPLEMENTARY AND WHAT IS REQUIRED BY ONE SHALL BE AS BINDING AS IF REQUIRED BY ALL. IN THE CASE OF A CONFLICT, DISAGREEMENT, OR AMBIGUITY, PROVIDE THE BETTER QUALITY. IN THE CASE OF A CONFLICT, DISAGREEMENT, OR AMBIGUITY, PROVIDE THE GREATER QUANTITY OF WORK.
- B. COORDINATE PIPING LOCATIONS AND INSTALLATION WITH EACH TRADE TO AVOID CONFLICTS WITH OTHER TRADES.
- C. PROVIDE FLOOR CLEANOUTS INDICATED FLUSH WITH FLOOR FINISHES.
- D. PROVIDE CLEANOUTS WHERE INDICATED AND ADDITIONAL CLEANOUTS AS REQUIRED BY LOCAL CODE.
- E. REFER TO DRAWINGS FROM EACH DISCIPLINE BEFORE ROUGHING-IN PLUMBING FIXTURES.
- F. OBTAIN DIMENSIONS AND ROUTING IN FIELD BEFORE INSTALLATION OF PLUMBING AND FIXTURES.
- G. INSTALL ALL DRAINAGE PATTERN FITTINGS AND PIPING IN ACCORDANCE WITH APPLICABLE FEDERAL, STATE, AND LOCAL CODES.
- H. REFER TO STRUCTURAL DRAWINGS FOR DETAILS AND MAXIMUM SPACING REQUIREMENTS REGARDING HANGER ATTACHMENTS TO STEEL BAR JOISTS.
- I. PROVIDE ISOLATION VALVES IN ACCORDANCE WITH DIAGRAMS, DETAILS, AND DIVISION 22 SPECIFICATIONS.

**ABBREVIATIONS**

@	AT	EWC	ELECTRIC WATER COOLER	OSD	OPEN SITE DRAIN
AAV	AIR ADMITTANCE VALVE	EWH	ELECTRIC WATER HEATER	PC	PRECAST
ABV	ABOVE	EXV	EXHAUST VALVE	PCF	POUNDS PER CUBIC FOOT
AC-X	AIR COMPRESSOR DESIGNATION	EXP	EXPANSION	PD	PUMP DISCHARGE
ADJ	ADJUSTABLE	FCO	FLOOR CLEANOUT	PLUMB	PLUMBING
ADNL	ADDITIONAL	FD	FLOOR DRAIN	PLYWD	PLYWOOD
AF	ABOVE FINISHED FLOOR	FDC	FIRE DEPARTMENT CONNECTION	PCLY	POLYETHYLENE
AFS	ABOVE FINISHED GRADE	FF	FINISHED FLOOR	PFT	PRESSURE PRESERVATIVE TREATED
AHU	AIR HANDLING UNIT	FFE	FINISHED FLOOR ELEVATION	PREFAB	PREFABRICATED
ALT	ALTERNATE	FG	FINISHED GRADE	PROJ	PROJECT
ALUM	ALUMINUM	FH	FIRE HYDRANT	PSF	POUNDS PER SQUARE FOOT
AP	ACCESS PANEL	FHC	FIRE HOSE CABINET	PSI	POUNDS PER SQUARE INCH
APPR	APPROXIMATE	FHS	FIRE HOSE STATION	PV	PROPANE VENT
ARCH	ARCHITECTURAL	FHVC	FIRE HOSE VALVE CABINET	PVC	POLYVINYL CHLORIDE
AUTO	AUTOMATIC	FX	FIXTURE	PVMT	PAVEMENT
AVG	AVERAGE	FLR	FLOOR	R	RISER
BFF	BELOW FINISHED FLOOR	FLSHG	FLASHING	RAD	RADIUS
BFG	BELOW FINISHED GRADE	FOR	FUEL OIL RETURN	RC-X	RECIRCULATION PUMP DESIGNATION
BLDG	BUILDING	FOS	FUEL OIL SUPPLY	RD	ROOF DRAIN (BOTTOM OUTLET)
BO	BOTTOM OF	FV	FUEL OIL VENT	RDS	ROOF DRAIN (SIDE OUTLET)
BOT	BOTTOM	FS	FLOOR SINK	REF	REFERENCE
BSMT	BASEMENT	FSD	FOUNDATION SUB-DRAIN	REQD	REQUIRED
BTWN	BETWEEN	FT	FOOT OR FEET	REQMT	REQUIREMENTS
CA	COMPRESSED AIR	FVC	FIRE VALVE CABINET	RL	RAIN LEADER
CI	CAST IRON	G	GAS	RM	ROOM
CP	CAST-IN-PLACE CONCRETE	GOD	GAS CLEANOUT	RO	ROUGH OPENING
CL	CENTERLINE	GWH	GAS WATER HEATER	RV	RADON VENT
CLG	CEILING	HB	HOSE BIBB	S	SOUTH
CLR	CLEAR	HORIZ	HORIZONTAL	SAN	SANITARY
CMP	CORRUGATED METAL PIPE	HP	HORSEPOWER	SCH	SCHEDULE
CNTR	COUNTERTOP	HRX	HOSE REEL DESIGNATION	SD	STORM DRAINAGE PIPING
CO	CLEANOUT	HTG	HOT WATER	SDN	STORM DRAIN NOZZLE
COL	COLUMN	HW	HOT WATER	SF	SQUARE FOOT/FEET
CONC	CONCRETE	HWR	HOT WATER RETURN	SHT	SHEET
CONDS	CONDENSATE	HWS	HOT WATER SUPPLY	SM	SIMILAR
CONSTR	CONSTRUCTION	ID	INSIDE DIAMETER	SLT	SEALANT
CONT	CONTINUATION	IN	INCH	SOG	SLAB ON GRADE
CONTR	CONTRACT(OR)	INSUL	INSULATE OR INSULATION	SP	SUMP PUMP
CORR	CORRIDOR	INV	INVERT	SPEC	SPECIFICATION
CP	CIRCULATING PUMP	JAN	JANITOR	SPR	SPRINKLER
CR	CLASSROOM	KIT	KITCHEN	SQ	SQUARE
CT	COOLING TOWER	KW	KITCHEN WASTE	SRD	SECONDARY ROOF DRAIN
CU	COPPER	LAB	LABORATORY	SS	STAINLESS STEEL
CU FT	CUBIC FEET	LAV	LAVATORY	SSD	SECONDARY STORM DRAINAGE PIPING
CU YD	CUBIC YARD	LBS	POUNDS	STD	STANDARD
CW	COLD WATER	LF	LINEAR FOOT (FEET)	STL	STEEL
DB	DRY BULB	LP	PROPANE	STOR	STORAGE
DCW	DOMESTIC COLD WATER	LPV	PROPANE VENT	STRUCT	STRUCTURAL
DEMO	DEMOLISH OR DEMOLITION	MATL	MATERIAL	SUSP	SUSPENDED
DF	DRINKING FOUNTAIN	MAX	MAXIMUM	TD	TROUGH DRAIN
DHR(140)	DOMESTIC HOT WATER RETURN (140°)	MECH	MECHANICAL	THK	THICKNESS
DHW(140)	DOMESTIC HOT WATER (140°)	MED	MEDIUM	TLT	TILE
DHW(140)	DOMESTIC HOT WATER (140°)	MFR	MANUFACTURER	TMV	THERMOSTATIC MIXING VALVE
DIA	DIAMETER	MH	MANHOLE	TOSL	TOP OF SLAB
DIP	DUCTILE IRON PIPE	MN	MINIMUM	TW	DOMESTIC TEMPERED WATER (90° F)
DN	DOWN	MISC	MISCELLANEOUS	TYP	TYPICAL
DR-X	COMPRESSED AIR DRYER DESIGNATION	MTD	MOUNTED	UG	UNDERGROUND
DS	DOWNSPOUT	N	NORTH	UNO	UNLESS NOTED (INDICATED) OTHERWISE
DT	DRAIN TILE	N/A	NOT APPLICABLE/AVAILABLE	V	VENT
DTL	DETAIL	NC	NORMALLY CLOSED	VAC	VACUUM
DTW	DOMESTIC TEMPERED WATER	NG	NATURAL GAS	VB	VACUUM BREAKER
DWG	DRAWING	NGV	NATURAL GAS VENT	VERT	VERTICAL
DWP	DOMESTIC WATER BOOSTER PUMP	NIC	NOT IN CONTRACT	VERIFY	VERIFY IN FIELD
E	EAST	NO	NORMALLY OPEN	VTR	VENT THROUGH ROOF
ED	EMERGENCY SECONDARY ROOF DRAIN	NO. (#)	NUMBER	W	WITH
ELEC	ELECTRICAL	NOM	NOMINAL	WI	WITHOUT
ELEV	ELEVATION	OC	ON CENTER	W/O	WITHOUT
EPSD	ELECTRICAL PANELBOARD	OD	OUTSIDE DIAMETER	WB	WATER HAMMER ARRESTER
EQ	EQUAL	OFCI	OWNER FURNISHED CONTRACTOR INSTALLED	WC	WATER CLOSET
EQUIP	EQUIPMENT	OFF	OFFICE	WCO	WALL CLEANOUT
ETR	EXISTING TO REMAIN	OH	OVERHEAD	WSPH	WATER SOURCE HEAT PUMP
		OPNG	OPENING	WWF	WELDED WIRE FABRIC
		OPP	OPPOSITE	WWM	WELDED WIRE MESH
				XMR	TRANSFORMER

**GRAPHICS SYMBOLS LEGEND**

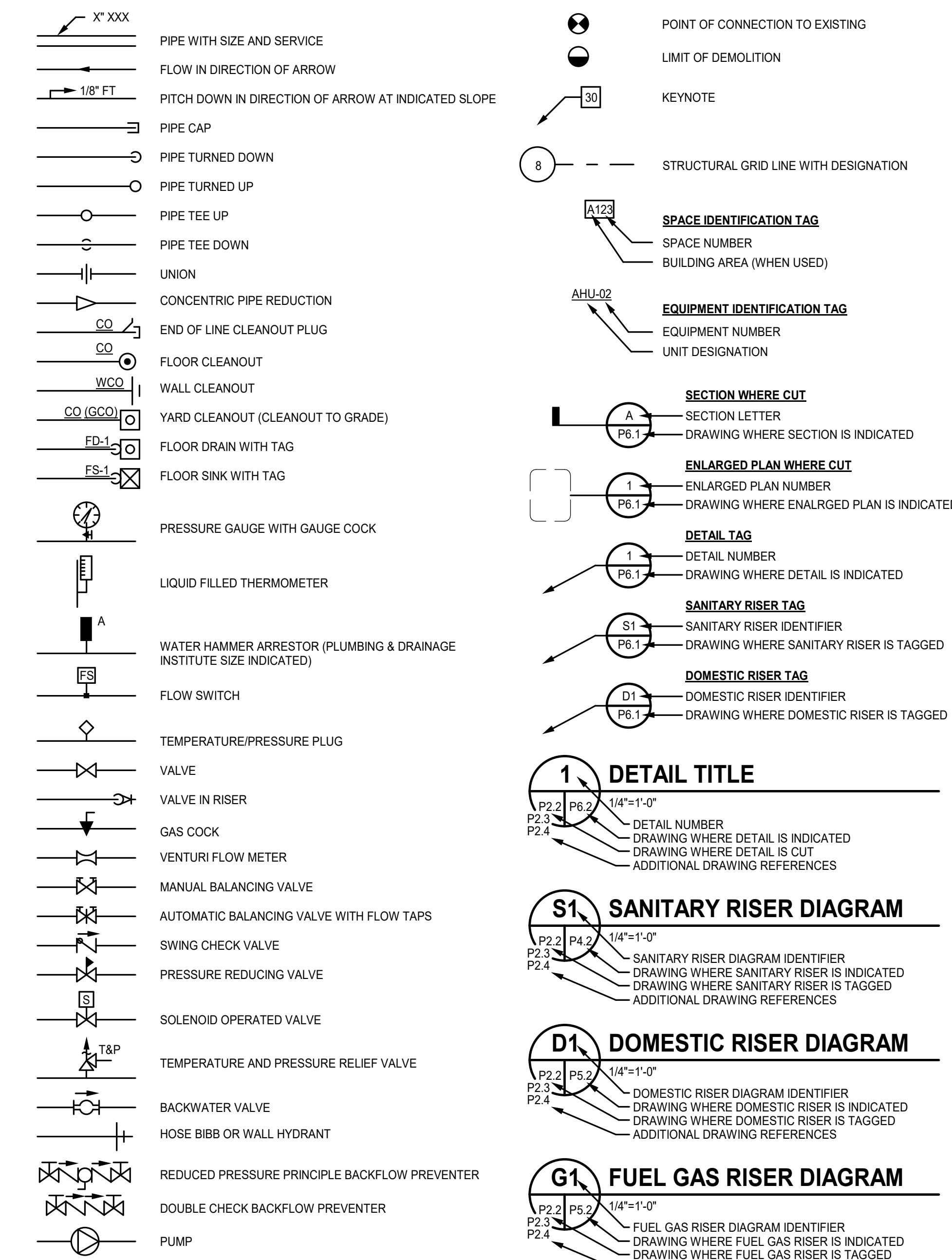

**PLUMBING FIXTURE SCHEDULE**

TAG	FIXTURE	HEIGHT A.F.F.	BASIS OF DESIGN	PIPE SIZE				NOTES
				COLD WATER	TEPID WATER	HOT WATER	VENT	
EX_HB	EXISTING HOSE BIBB	CENTERLINE OF OUTLET AT 18"	FIXTURE: ZURN Z1341XL	3/4"				
EX_P2-B	EXISTING SINK - DOUBLE BASIN	COUNTER MOUNTED REFER TO ARCH DWGS	FIXTURE: ELKAY LRADQ33255 FAUCET: ZURN ZB2300-XL-CPB-7M-HS	1/2"		1/2"	1 1/2"	1 1/2"
SK-1	SINK - SINGLE BASIN BARRIER FREE	COUNTER MOUNTED REFER TO ARCH DWGS	FIXTURE: ELKAY LRADQ221955	1/2"		1/2"	1 1/2"	1 1/2"
SK-2	SINK - SINGLE BASIN BARRIER FREE	COUNTER MOUNTED REFER TO ARCH DWGS	FIXTURE: ELKAY LRADQ151750	1/2"		1/2"	1 1/2"	1 1/2"
WSB-1	ICE MAKER OUTLET BOX	BOTTOM AT 6"	FIXTURE: GUY GRAY BIM675QTSAB	1/2"				

NOTES:  
 1. ALL PLUMBING FIXTURE SHALL CONTAIN THE WATERSENSE LABEL.  
 2. THIS ACCESSIBLE FIXTURE, ACCESSORIES, AND INSTALLATION SHALL CONFORM TO THE USBC AND ASADA STANDARDS FOR ACCESSIBLE DESIGN.  
 3. PROVIDE INSINKERATOR BADGER-6 1/2HP 120V PLUG AND CORD UNDER SINK.

**ELECTRIC WATER HEATER SCHEDULE**

TAG	BASIS OF DESIGN		LOCATION	CAPACITY (GALLONS)	RECOVERY RATE (GPM)	TEMPERATURE RISE (°F)	TEMPERATURE SETTING (°F)	ELECTRICAL DATA			NOTES	
	MANUFACTURER	MODEL						INPUT RATE (KW)	VOLTAGE	PHASE		HERTZ
EWH-1	EEMAX	AM004277T	BREAKROOM	0	0.5	56	95	4.1	277	1	60	

NOTES:  
 1. INSTANTANEOUS POINT OF USE WATER HEATER.

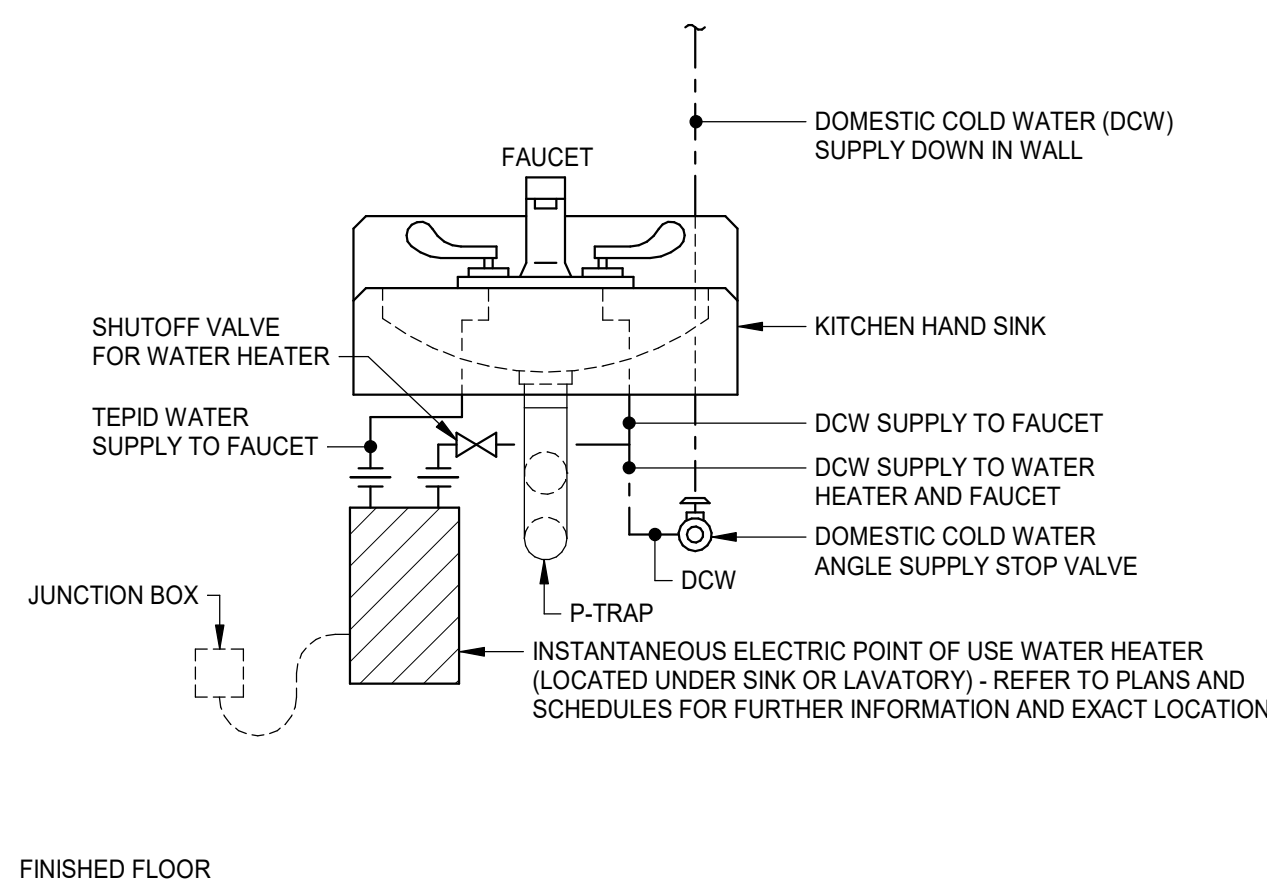

**1 INSTANTANEOUS ELECTRIC POINT-OF-USE WATER HEATER DETAIL**  
1/2" = 1'-0"

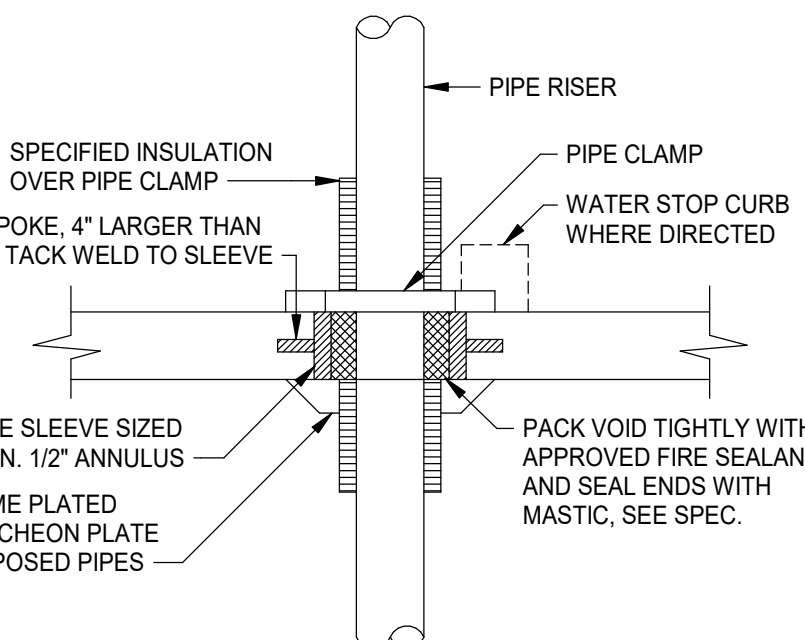

**2 PIPE THRU FLOOR SLAB DETAIL**  
1/8" = 1'-0"

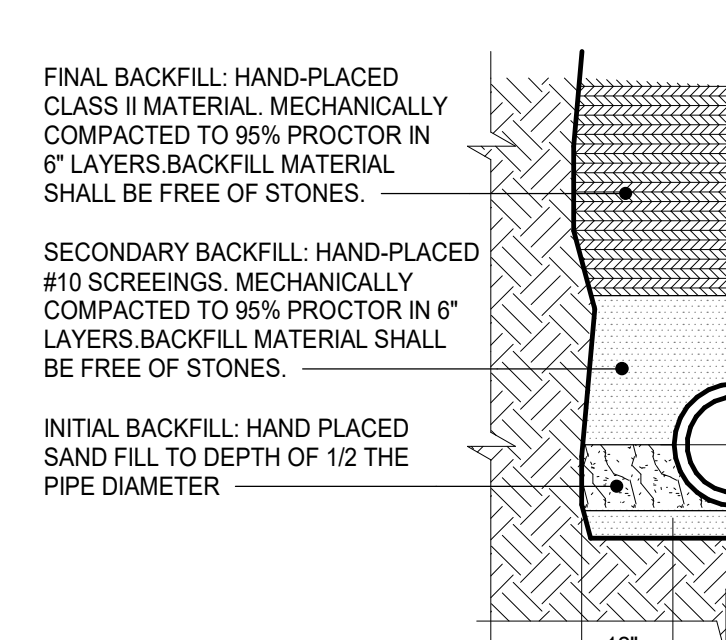

**3 PVC PIPE BEDDING DETAIL**  
1/2" = 1'-0"

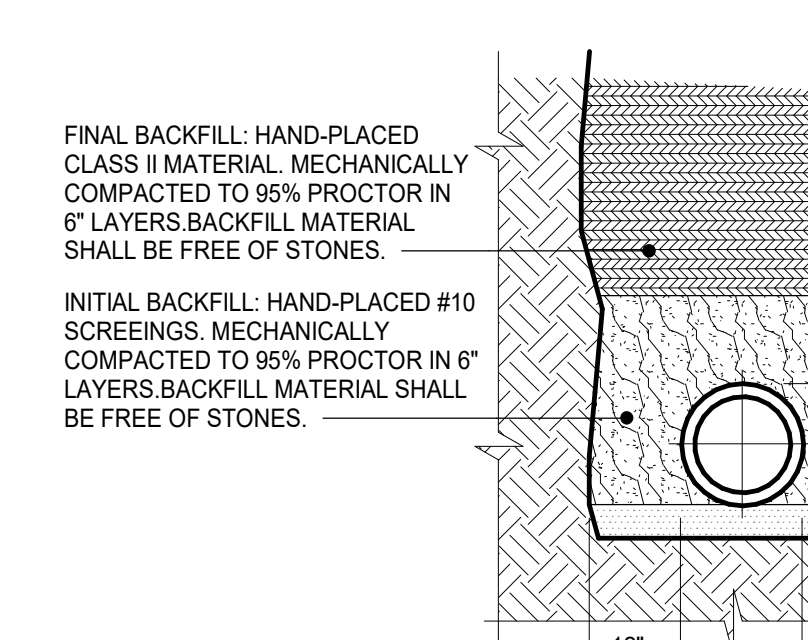

**4 CAST IRON PIPE BEDDING DETAIL**  
1/2" = 1'-0"

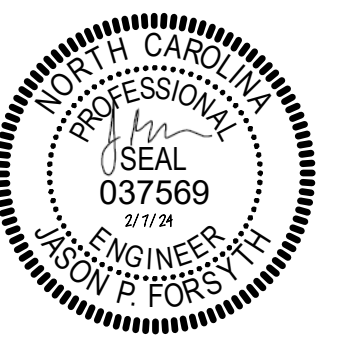

KEYNOTES	
APPLIES TO THIS DRAWING	
REPRESENTED BY [n]	
1.	RESIDENT UNIT ISOLATION VALVE.
2.	1/2" DOW DOWN TO ICE MAKER.
3.	2" VTR.
4.	1-1/2" SAN TO KITCHEN SINK.
5.	1/2" DOW DOWN TO KITCHEN SINK.
6.	1/2" DHW FROM ACCUMIX THERMOSTATIC HEATER TO KITCHEN SINK.
7.	1/2" DOW TO UNDERCOUNTER ICE MAKER.
8.	ACCUMIX THERMOSTATIC HEATER.

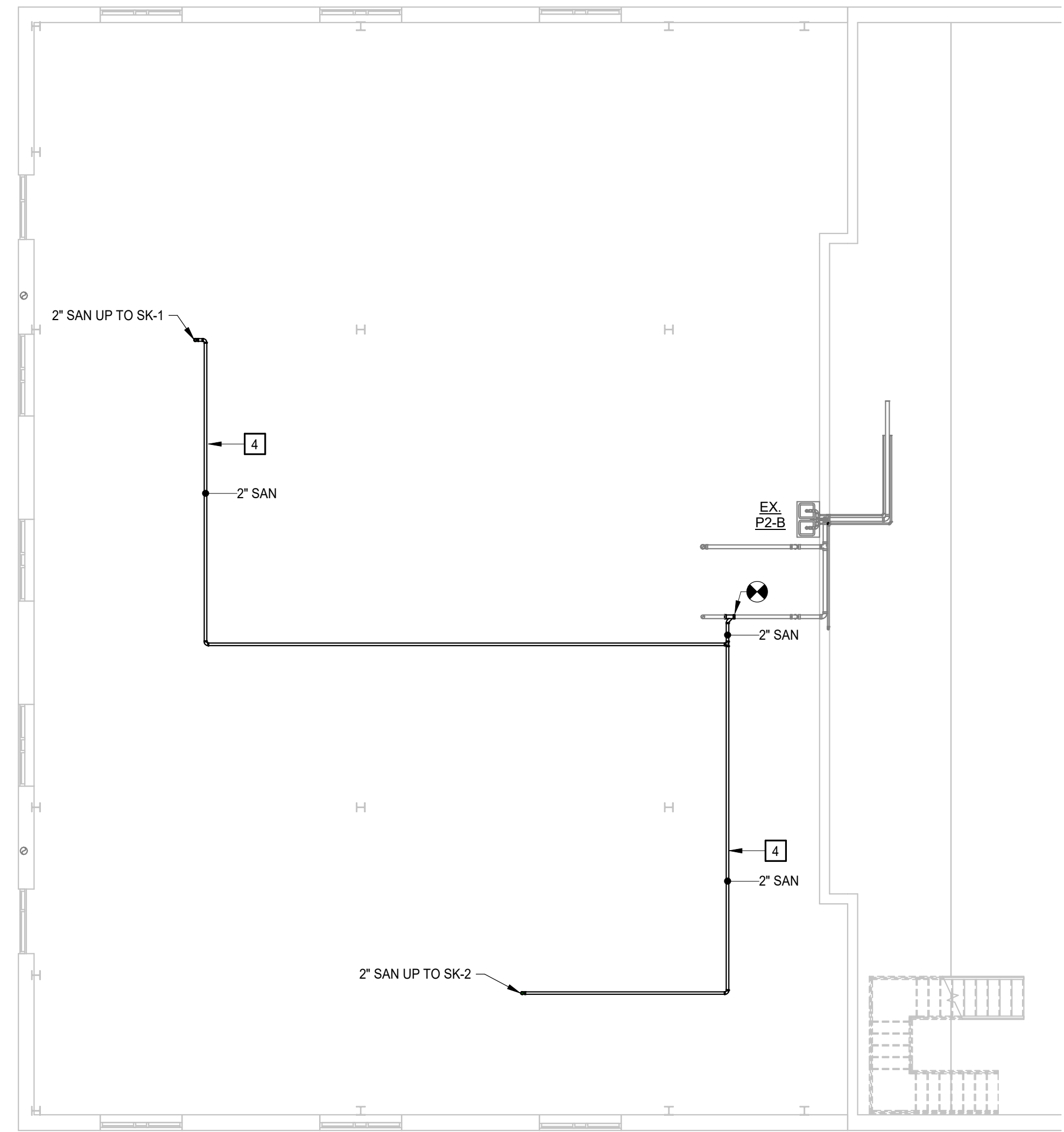

**1 FIRST FLOOR PLAN - PLUMBING**  
1/8" = 1'-0"

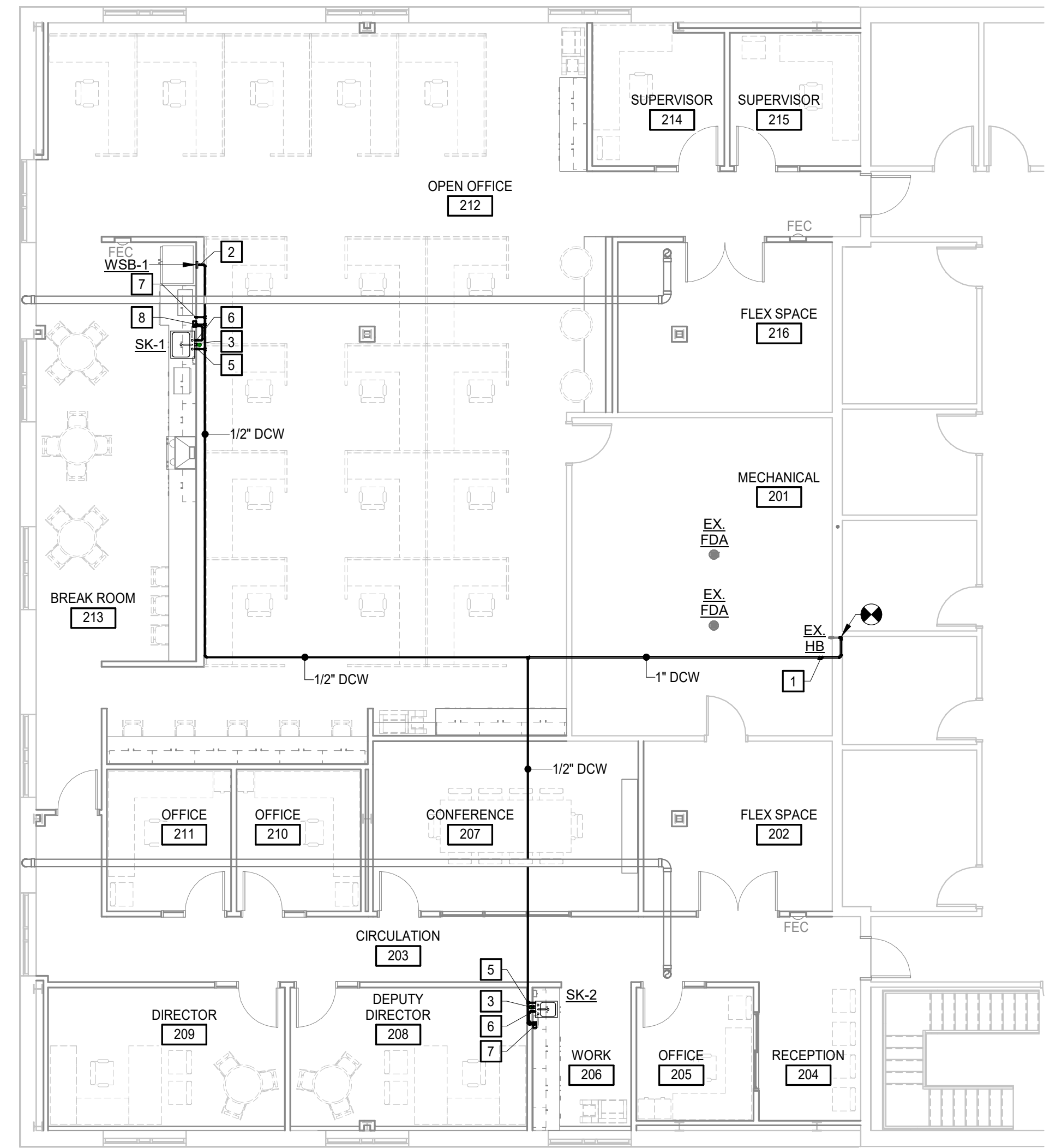

**2 SECOND FLOOR PLAN - PLUMBING**  
1/8" = 1'-0"

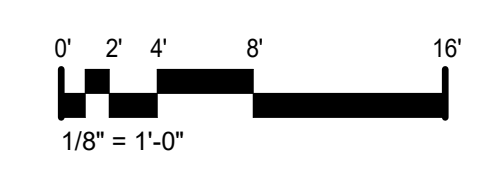

PROJECT NO:	631797
DATE:	FEBRUARY 07, 2024
REVISIONS	
DATE	DESCRIPTION

DATE	DESCRIPTION

### EQUIPMENT ABBREVIATION

AHU	AIR-HANDLING UNIT
AS	AIR SEPARATOR
B	BOILER
BCU	BLOWER COIL UNIT
OCC	CLOSED-CIRCUIT COOLING TOWER
CH	CHILLER
CHWP	CHILLED WATER PUMP
CRAC	COMPUTER ROOM AIR CONDITIONER
CT	COOLING TOWER
CUH	CABINET UNIT HEATER
CWP	CONDENSER WATER PUMP
ECH	ELECTRIC CEILING HEATER
ERV	ENERGY RECOVERY UNIT
ERU	ENERGY RECOVERY UNIT
ET	EXPANSION TANK
EUH	ELECTRIC UNIT HEATER
FCU	FAN COIL UNIT
HP	HEAT PUMP
HWP	HOT WATER PUMP
HX	HEAT EXCHANGER
MAU	MAKEUP AIR UNIT
OAU	OUTDOOR AIR UNIT
P	PUMP
PTAC	PACKAGED TERMINAL AIR CONDITIONER
PTHF	PACKAGED TERMINAL HEAT PUMP
RTU	ROOFTOP UNIT
SSI	SPLIT-SYSTEM INDOOR UNIT
SSO	SPLIT-SYSTEM OUTDOOR UNIT
TU	TERMINAL UNIT
UH	UNIT HEATER
WSHP	WATER-SOURCE HEAT PUMP

### CONTROLS ABBREVIATIONS

AF	AIRFLOW
AI	ANALOG INPUT TO CONTROLLER
ALM	ALARM
AMS	AIRFLOW MEASURING STATION
AO	ANALOG OUTPUT FROM CONTROLLER
ATS	AVERAGING TEMPERATURE SENSOR
BAS	BUILDING AUTOMATION SYSTEM
BI	BINARY INPUT TO CONTROLLER
BO	BINARY OUTPUT FROM CONTROLLER
CO2	CARBON DIOXIDE SENSOR
CSR	CURRENT-SENSING RELAY
DM	DAMPER MOTOR
DP	DIFFERENTIAL PRESSURE
DPT	DIFFERENTIAL PRESSURE TRANSMITTER
FM	FLOW METER
FZ	FREEZESTAT
HS	HUMIDITY SENSOR
POS	POSITION RELAY
R	RELAY
SD	SMOKE DETECTOR
SPD	SPEED
SS	START/STOP
STS	STATUS
TS	TEMPERATURE SENSOR
VFD	VARIABLE-FREQUENCY DRIVE

### CONTROL SYMBOL LEGEND

	CIRCULATOR OR PUMP		NORMALLY OPEN CONTACT
	MOTORIZED 2-WAY VALVE		NORMALLY CLOSED CONTACT
	MOTORIZED 3-WAY VALVE		WIRING OR DEVICE PROVIDED UNDER DIVISION 23
	VARIABLE FREQUENCY DRIVE		WIRING OR DEVICE NOT PROVIDED UNDER DIVISION 23
	DIRECT DIGITAL CONTROLLER		WIRING CONNECTION BY DIVISION 23
	THERMOSTAT		WIRING CONNECTION BY OTHERS
	FREEZESTAT		NUMBER OF CONDUCTORS INDICATED BY SLASH MARKS
	CONTACTOR		MOTORIZED PARALLEL BLADE DAMPER
	RELAY		MOTORIZED OPPOSED BLADE DAMPER
	SPACE TEMPERATURE SENSOR		MOTORIZED BUTTERFLY BLADE DAMPER
	LINE VOLTAGE THERMOSTAT		SUPPLY, RETURN, OR EXHAUST FAN
	HAND-OFF-AUTOMATIC SWITCH		AIRFLOW DIRECTION
	DUCT-MOUNTED SMOKE DETECTOR		CONTROL POINT INDICATOR
	TRANSFORMER		INPUT OR OUTPUT (ANALOG INPUT)
	FUSE		DEVICE TYPE (AIR TEMPERATURE SENSOR)
			CONTROL POINT INDICATOR
			INPUT OR OUTPUT (ANALOG INPUT)
			DEVICE TYPE (WATER TEMPERATURE SENSOR)
			CONTROL POINT INDICATOR
			INPUT OR OUTPUT (ANALOG INPUT)
			DEVICE TYPE (CURRENT SENSING RELAY)

### ABBREVIATIONS

A	AMPERES
AD	ACCESS DOOR
AFF	ABOVE FINISHED FLOOR
ALT	ALTERNATE
APD	AIR PRESSURE DROP
DHP	DRIVE HORSEPOWER
BTUH	BRITISH THERMAL UNITS PER HOUR
CFM	CUBIC FEET PER MINUTE
CHWR	CHILLED WATER RETURN
CHWS	CHILLED WATER SUPPLY
CLG	COOLING
COM	COMMON
CWR	CONDENSER WATER RETURN
CWS	CONDENSER WATER SUPPLY
D	DRAIN
DB	DRY BULB TEMPERATURE
dBA	A-WEIGHTED DECIBELS
DCW	DOMESTIC COLD WATER
DIA	DIAMETER
DN	DOWN
DWG	DRAWING
EA	EXHAUST AIR
EAT	ENTERING AIR TEMPERATURE
EER	ENERGY EFFICIENCY RATIO
EQ	EQUAL
ESP	EXTERNAL STATIC PRESSURE
EWT	ENTERING WATER TEMPERATURE
EX	EXISTING
F	DEGREES FAHRENHEIT
FC	FALL CLOSED
FD	FIRE DAMPER
FLA	FULL LOAD AMPS
FO	FAIL OPEN
PFM	FEET PER MINUTE
FT	FOOT, FEET
GA	GAUGE
GAL	GALLON(S)
GPH	GALLONS PER HOUR
GPM	GALLONS PER MINUTE
HP	HORSEPOWER
HPWR	HEAT PUMP WATER RETURN
HPWS	HEAT PUMP WATER SUPPLY
HTG	HEATING
HWR	HOT WATER RETURN
HWS	HOT WATER SUPPLY
HX	HEAT EXCHANGER
HZ	HERTZ
IN	INCH
PLV	INTEGRATED PART-LOAD VALUE
KW	KILOWATT(S)
LAT	LEAVING AIR TEMPERATURE
LBS	POUNDS
LWT	LEAVING WATER TEMPERATURE
MAX	MAXIMUM
MBH	ONE THOUSAND BTUH
MCA	MINIMUM CIRCUIT AMPACITY
MFR	MANUFACTURER
MIN	MINIMUM
MOCP	MAXIMUM OVERCURRENT PROTECTION
MOD	MOTOR-OPERATED DAMPER
NC	NORMALLY CLOSED (FOR PLANS, DETAILS)
NC	NOISE CRITERIA (FOR SCHEDULES)
NIC	NOT IN CONTRACT
NO	NORMALLY OPEN
OA	OUTSIDE AIR
OC	ON CENTER
OFCI	OWNER FURNISHED CONTRACTOR INSTALLED
PH	PHASE
PSIG	POUNDS PER SQUARE INCH GAUGE
RA	RETURN AIR
RD	REFRIGERANT DISCHARGE
RH	RELATIVE HUMIDITY
RL	REFRIGERANT LIQUID
RPM	REVOLUTIONS PER MINUTE
RS	REFRIGERANT SUCTION
SA	SUPPLY AIR
SEER	SEASONAL ENERGY EFFICIENCY RATIO
TD	TRANSFER DUCT
TYP	TYPICAL
UNO	UNLESS NOTED (INDICATED) OTHERWISE
V	VOLTAGE, VOLTS
VD	VOLUME DAMPER
VFD	VARIABLE FREQUENCY DRIVE
VIF	VERIFY IN FIELD
W	WATT(S)
WF	WITH
W/O	WITHOUT
WB	WET BULB TEMPERATURE
WC	WATER COLUMN
WPD	WATER PRESSURE DROP
WMM	WELDED WIRE MESH

### GRAPHIC SYMBOL LEGEND

	SPACE TAG		DETAIL TITLE
	SPACE NAME		DETAIL NUMBER
	SPACE NUMBER		DRAWING WHERE DETAIL IS INDICATED
	BUILDING PART NUMBER		DRAWING WHERE DETAIL IS REFERENCED
	EQUIPMENT TAG		SECTION TITLE
	EQUIPMENT NUMBER		SECTION NUMBER
	EQUIPMENT ABBREVIATION		DRAWING WHERE SECTION IS INDICATED
	DIFFUSER, GRILLE OR REGISTER TAG		DRAWING WHERE SECTION IS REFERENCED
	TAG, REFER TO DIFFUSER, GRILLE AND REGISTER SCHEDULE		ADDITIONAL DRAWING REFERENCES
	AIRFLOW (CFM)		SECTION CALLOUT
	DETAIL TAG		DRAWING WHERE SECTION IS INDICATED
	DETAIL NUMBER		DRAWING WHERE SECTION IS REFERENCED
	DRAWING WHERE DETAIL IS INDICATED		ENLARGED PLAN CALLOUT
	KEYNOTE		DRAWING WHERE ENLARGED PLAN IS INDICATED
	STRUCTURAL GRID LINE WITH DESIGNATION		MECHANICAL EQUIPMENT WITH REQUIRED SERVICE CLEARANCE INDICATED
	EXISTING TO BE REMOVED		

### DUCTWORK LEGEND

	RECTANGULAR DUCT (FIRST DIMENSION REFERS TO SIDE VIEWED)		MANUAL BALANCING DAMPER IN DUCT
	ROUND DUCT SIZE		FIRE DAMPER IN DUCT
	FLAT OVAL DUCT SIZE		SMOKE DAMPER IN DUCT
	DOUBLE WALL, EXPOSED DUCT		COMBINATION FIRE/SMOKE DAMPER IN DUCT
	FABRIC DUCT		FIRE DAMPER WITH SECURITY BARS IN DUCT
	FLEXIBLE DUCTWORK		SMOKE DAMPER WITH SECURITY BARS IN DUCT
	FLEXIBLE CONNECTOR		COMBINATION FIRE/SMOKE DAMPER WITH SECURITY BARS IN DUCT
	DUCT-MOUNTED SMOKE DETECTOR		MOTORIZED DAMPER IN DUCT
	DUCT WITH DUCT LINER		SMOKE CONTROL MANUAL BALANCING DAMPER IN DUCT
	DUCT ACCESS DOOR		SMOKE CONTROL MOTORIZED DAMPER IN DUCT
	DUCT WITH END CAP		SECURITY BARS IN DUCT
	LINEAR SLOT DIFFUSER, LENGTH AS INDICATED		DUCT WITH ACCESS PANEL
	LINEAR BAR GRILLE, LENGTH AS INDICATED		SUPPLY/MAKEUP AIR DUCT SECTIONS
	SUPPLY DIFFUSER		RETURN AIR DUCT SECTIONS
	RETURN OR EXHAUST GRILLE		EXHAUST AIR DUCT SECTIONS
	SUPPLY DIFFUSER WITH DIRECTIONAL BLOW, SOLID HATCH INDICATES BLAM OFF PANEL		SMOKE DETECTOR
	POINT OF CONNECTION TO EXISTING		HUMIDITY SENSOR
	LIMIT OF DEMOLITION		THERMOSTAT, LINE VOLTAGE
	SUPPLY AIRFLOW ARROW		THERMOSTAT, LOW VOLTAGE
	RETURN OR EXHAUST AIRFLOW ARROW		TEMPERATURE SENSOR
	DOOR UNDERCUT		CARBON DIOXIDE SENSOR
	DOOR LOUVER		CARBON MONOXIDE SENSOR
	SENSOR WELL		

### PIPING LEGEND

	END OF LINE CLEANOUT PLUG		VALVE
	CLEANOUT PLUG		MANUAL BALANCING VALVE WITH FLOW TAPS
	PRESSURE GAUGE WITH GAUGE COCK		AUTOMATIC BALANCING VALVE WITH FLOW TAPS
	LIQUID FILLED THERMOMETER		SWING CHECK VALVE
	UNION		PRESSURE REDUCING VALVE
	STRAINER WITH BLOWDOWN VALVE AND 3/4" HOSE END CONNECTION		TRIPLE DUTY VALVE
	FLEXIBLE PIPE CONNECTOR		GAS COCK
	MANUAL AIR VENT		PRESSURE-RELIEF VALVE
			TWO-WAY CONTROL VALVE
			THREE-WAY CONTROL VALVE
			DIRECTION OF FLOW

### GENERAL NOTES

- THE CONTRACT DOCUMENTS ARE COMPLEMENTARY AND WHAT IS REQUIRED BY ONE SHALL BE AS BINDING AS IF REQUIRED BY ALL. IN THE CASE OF A CONFLICT, DISAGREEMENT, OR AMBIGUITY, PROVIDE THE GREATER QUANTITY OF WORK.
- DRAWINGS ARE DIAGRAMMATIC AND INTENDED TO CONVEY SCOPE AND GENERAL ARRANGEMENT ONLY. DO NOT SCALE DRAWINGS. LOCATIONS OF ALL ITEMS INDICATED ON THE DRAWINGS OR CALLED FOR IN THE SPECIFICATIONS THAT ARE NOT DEFINITELY FIXED BY DIMENSIONS ARE APPROXIMATE. COORDINATE CONTRACT DOCUMENTS PROJECT REQUIREMENTS, WORK OF OTHERS, AND EQUIPMENT AND MATERIALS PURCHASED WITH FIELD DIMENSIONS, MANUFACTURER'S REQUIREMENTS FOR INSTALLATION, OPERATION, AND MAINTENANCE. CONTRACTOR'S INTENDED MEANS AND METHODS OF INSTALLATION, AND CONTRACTOR'S FABRICATED ITEMS TO ENSURE A PROPER FIT AND INSTALLATION.
- MAINTAIN MAXIMUM HEADROOM AND SPACE CONDITIONS AT ALL POINTS, WHERE HEADROOM AND SPACE CONDITIONS APPEAR INADEQUATE, NOTIFY THE ARCHITECTS PRIOR TO PROCEEDING WITH INSTALLATION. MAINTAIN A MINIMUM OF 7'-0" CLEARANCE ABOVE FINISHED FLOOR TO UNDERSIDE OF PIPES, DUCTS, CONDUTS, SUSPENDED EQUIPMENT, ETC., THROUGHOUT ACCESS ROUTES IN MECHANICAL ROOMS.
- FIELD VERIFY AND COORDINATE ALL DUCT AND PIPING DIMENSIONS BEFORE FABRICATION. MAKE MODIFICATIONS IN THE LAYOUT AS NEEDED TO PREVENT CONFLICT WITH WORK OF OTHER TRADES OR FOR PROPER EXECUTION OF THE WORK.
- INSTALL ALL EQUIPMENT AND APPURTENANCES IN ACCORDANCE WITH MANUFACTURER'S RECOMMENDATIONS, CONTRACT DOCUMENTS, AND APPLICABLE CODES AND REGULATIONS.
- COORDINATE LOCATIONS AND SIZES OF ALL FLOOR, WALL, AND ROOF OPENINGS WITH ALL OTHER TRADES. COORDINATE ALL PIPING AND EQUIPMENT SUPPORTED FROM STRUCTURE WITH GENERAL CONSTRUCTION WORK.
- PROVIDE TRAPPED DRAIN PIPING FROM DRAIN PANS OF ALL COOLING COILS, FANS AND OTHER ACTIVE DRAINS EXPOSED TO SYSTEM AIRSTREAM. PROVIDE TRAP AT CONNECTION WITH WATER SEAL DEPTH ONE INCH GREATER THAN UNIT OPERATING PRESSURE. DIRECT DRAINS TO NEAREST FLOOR DRAIN, MOP SINK, OR OTHER LOCATION APPROVED BY THE ARCHITECT.
- INSTALL PIPING, DUCTWORK, AND CONDUT CONCEALED IN AREAS HAVING CEILINGS AND/OR FURRED SPACES UNLESS OTHERWISE INDICATED.
- ALL EQUIPMENT, VALVES, DAMPERS, DAMPER AND VALVE OPERATORS SHALL BE PROVIDED WITH ADEQUATE ACCESS FOR SERVICING, MAINTENANCE, AND REPLACEMENT.
- SIZE ALL SPLIT-SYSTEM REFRIGERANT PIPING IN ACCORDANCE WITH THE MANUFACTURER'S INSTALLATION INSTRUCTIONS.
- DUCT DIMENSIONS MAY BE MODIFIED ONLY WITH PRIOR APPROVAL FROM ARCHITECT. DUCT DIMENSIONS ARE IN INCHES AND INSIDE CLEAR.
- FOR LOCATION OF REGISTERS, GRILLES, AND DIFFUSERS WITHIN CEILING GRID, REFER TO ARCHITECTURAL REFLECTED CEILING PLANS.
- ELEVATION INDICATED FOR RECTANGULAR DUCT, GRILLE AND LOUVER OPENINGS IS TO THE TOP OF ROUGH OPENING UNLESS OTHERWISE INDICATED. ELEVATION INDICATED FOR ROUND DUCTWORK AND PIPING IS TO CENTERLINE.
- BRANCH PIPING RUNOUTS TO TERMINAL UNITS SHALL BE 3/4" DIAMETER UNLESS INDICATED OTHERWISE.
- REFER TO STRUCTURAL DRAWINGS FOR DETAILS AND MAXIMUM SPACING REQUIREMENTS REGARDING HANGER ATTACHMENTS TO STEEL BAR JOISTS.

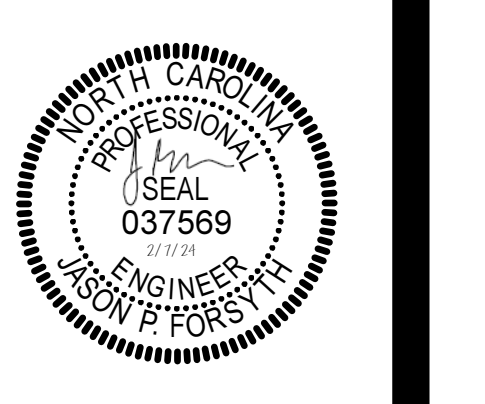

PROJECT NO:	631797
DATE:	FEBRUARY 7, 2024
REVISIONS	
DATE	DESCRIPTION

J  
I  
H  
G  
F  
E  
D  
C  
B  
A

### FAN POWERED TERMINAL UNIT SCHEDULE

TAG	MANUFACTURER	MODEL NUMBER	AIR VALVE				FAN				COIL										ELECTRICAL DATA				WEIGHT (LBS)	
			INLET DIAMETER (IN)	MAXIMUM AIR FLOW (CFM)	MINIMUM AIR FLOW (CFM)	APD AT MAXIMUM AIR FLOW (IN W/C)	FAN SIZE	MOTOR (HP)	AIRFLOW (CFM)	ESP (IN W/C)	DESIGN AIRFLOW (CFM)	CAPACITY (BTUH)	EAT (°F)	LAT (°F)	FLOW RATE (GPM)	WATER PRESSURE DROP (FT W/C)	EWT (°F)	LWT (°F)	ROWS (NO)	FLA (A)	MCA (A)	MOCP (A)	Ø0	(PHI)		(HZ)
VAV-1	TRANE	VSWF	6	400	60	0.24	03SQ	1/3	400	0.25	400	12,170	67.5	98.7	0.5	0.07	180	131.3	1	2.4	3.0	15	277	1	60	88
VAV-3	TRANE	VSWF	6	280	60	0.13	03SQ	1/3	280	0.25	280	11,480	66.8	104.6	0.5	0.07	180	134.1	1	2.4	3.0	15	277	1	60	88
VAV-4	TRANE	VSWF	6	350	60	0.22	03SQ	1/3	350	0.25	350	12,130	67.1	99.0	0.5	0.07	180	131.5	1	2.4	3.0	15	277	1	60	88
VAV-5	TRANE	VSWF	10	1200	210	0.39	04SQ	1/2	1200	0.25	1200	25,150	67.4	86.7	1.0	0.25	180	129.7	1	3.5	4.4	15	277	1	60	103
VAV-6	TRANE	VSWF	10	920	215	0.27	03SQ	1/3	920	0.25	920	19,910	68.5	86.5	1.0	0.15	180	126.9	1	2.4	3.0	15	277	1	60	92
VAV-7	TRANE	VSWF	8	680	105	0.29	03SQ	1/3	680	0.25	680	13,840	67.7	86.4	0.5	0.07	180	124.6	1	2.4	3.0	15	277	1	60	89
VAV-8	TRANE	VSWF	6	285	60	0.10	03SQ	1/3	285	0.25	285	11,080	66.3	108.0	0.5	0.07	180	135.7	1	2.4	3.0	15	277	1	60	88

### TERMINAL UNIT SCHEDULE

TAG	MANUFACTURER	MODEL NUMBER	AIR VALVE				COIL										WEIGHT (LBS)
			INLET DIAMETER (IN)	MAXIMUM AIRFLOW (CFM)	MINIMUM AIRFLOW (CFM)	APD AT MAX AIR FLOW (IN W/C)	DESIGN AIRFLOW (CFM)	CAPACITY (BTUH)	EAT (°F)	LAT (°F)	FLOW RATE (GPM)	FLUID PRESSURE DROP (FT W/C)	EWT (°F)	LWT (°F)	ROWS (NO)		
VAV-2	TRANE	VCWF	6	360	100	0.23	100	6,150	55	111.7	0.5	0.5	180	157.7	1	25.2	

### GRILLE, REGISTER, & DIFFUSER SCHEDULE

TAG	MANUFACTURER	MODEL NUMBER	MOUNTING STYLE	NECK SIZE	FACE SIZE	NOTES
S1	PRICE	ASCD	LAY-IN	6ø	24x24	-
S2	PRICE	ASCD	LAY-IN	8ø	24x24	-
S3	PRICE	ASCD	LAY-IN	10ø	24x24	-
R1	PRICE	635-TB-L	LAY-IN	22x22	24x24	1

NOTES:  
1. PROVIDE RETURN AIR CANOPY FOR EACH.

### EXISTING AIR HANDLING UNIT SCHEDULE

TAG	DESIGN AIRFLOW (CFM)	MAXIMUM OUTSIDE AIR DESIGN AIRFLOW (CFM)	MINIMUM OUTSIDE AIR FLOW (CFM)	HYDRONIC COOLING COIL				HYDRONIC HEATING COIL				NOTES		
				TOTAL CAPACITY (BTUH)	SENSIBLE CAPACITY (BTUH)	EWT (°F)	LWT (°F)	WATER FLOW RATE (GPM)	HEATING AIR FLOW (CFM)	SENSIBLE CAPACITY (BTUH)	EWT (°F)		LWT (°F)	WATER FLOW RATE (GPM)
AHU-30	4,400	750	310	158,200	122,000	45	61	20	2,500	114,200	180	180	12	1

NOTES:  
1. UNIT IS EXISTING TO REMAIN. PERFORM PRE-CONSTRUCTION TEST AND BALANCE TO DETERMINE EXISTING TOTAL AIRFLOW AND OUTSIDE AIRFLOW. RE-BALANCE UNIT TOTAL AIRFLOW AND OUTSIDE AIR INTAKE TO VALUES LISTED.



PROJECT NO:	631797
DATE:	FEBRUARY 7, 2024
REVISIONS	DESCRIPTION
DATE	DESCRIPTION



 **SECOND FLOOR PLAN - DEMOLITION**  
3/16" = 1'-0"

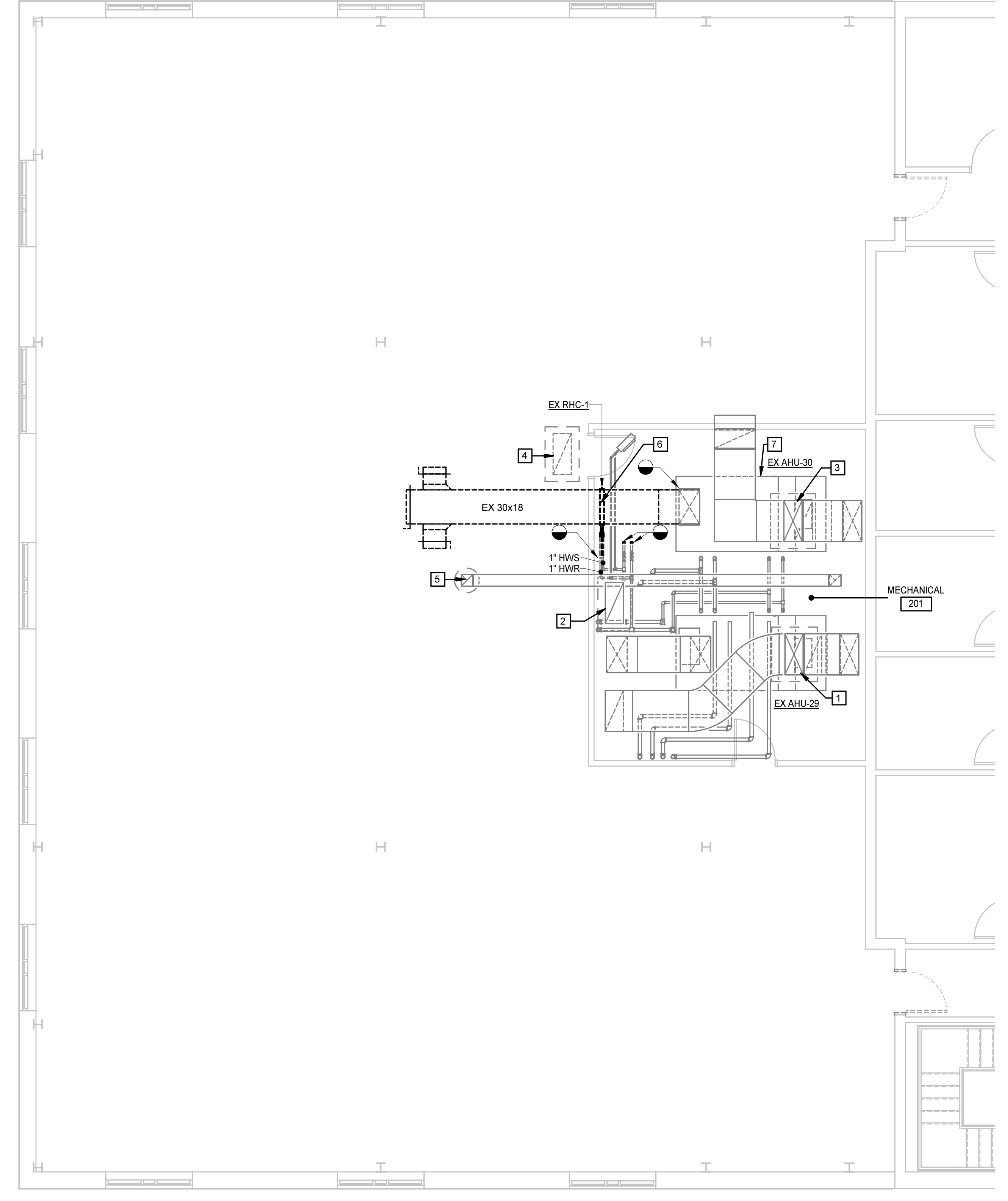

KEYNOTES	
APPLIES TO THIS DRAWING	
1	EX 36x16 UP TO EX IH-29.
2	EX 16x36 UP TO EX RH-29.
3	EX 36x16 UP TO EX IH-30.
4	EX 16x36 UP TO EX RH-30.
5	EX 10x10 UP TO EX EF-29-01.
6	REMOVE EXISTING HOT WATER COIL AND ALL ASSOCIATED ACCESSORIES.
7	PERFORM PRE-CONSTRUCTION TESTING FOR AIR HANDLING UNIT PRIOR TO ANY DEMOLITION WORK. REFER TO SPECIFICATION SECTION 014520 FOR REQUIREMENTS.



PROJECT NO.	631797
DATE	FEBRUARY 7, 2024
REVISIONS	
DATE	DESCRIPTION



KEYNOTES	
APPLIES TO THIS DRAWING	
1	EX 36x16 UP TO EX IH-29.
2	EX 16x36 UP TO EX RH-29.
3	EX 36x16 UP TO EX IH-30.
4	EX 16x36 UP TO EX RH-30.
5	EX 10x10 UP TO EX EF-29-01.
6	8x8 UP TO GOOSENECK ON ROOF.

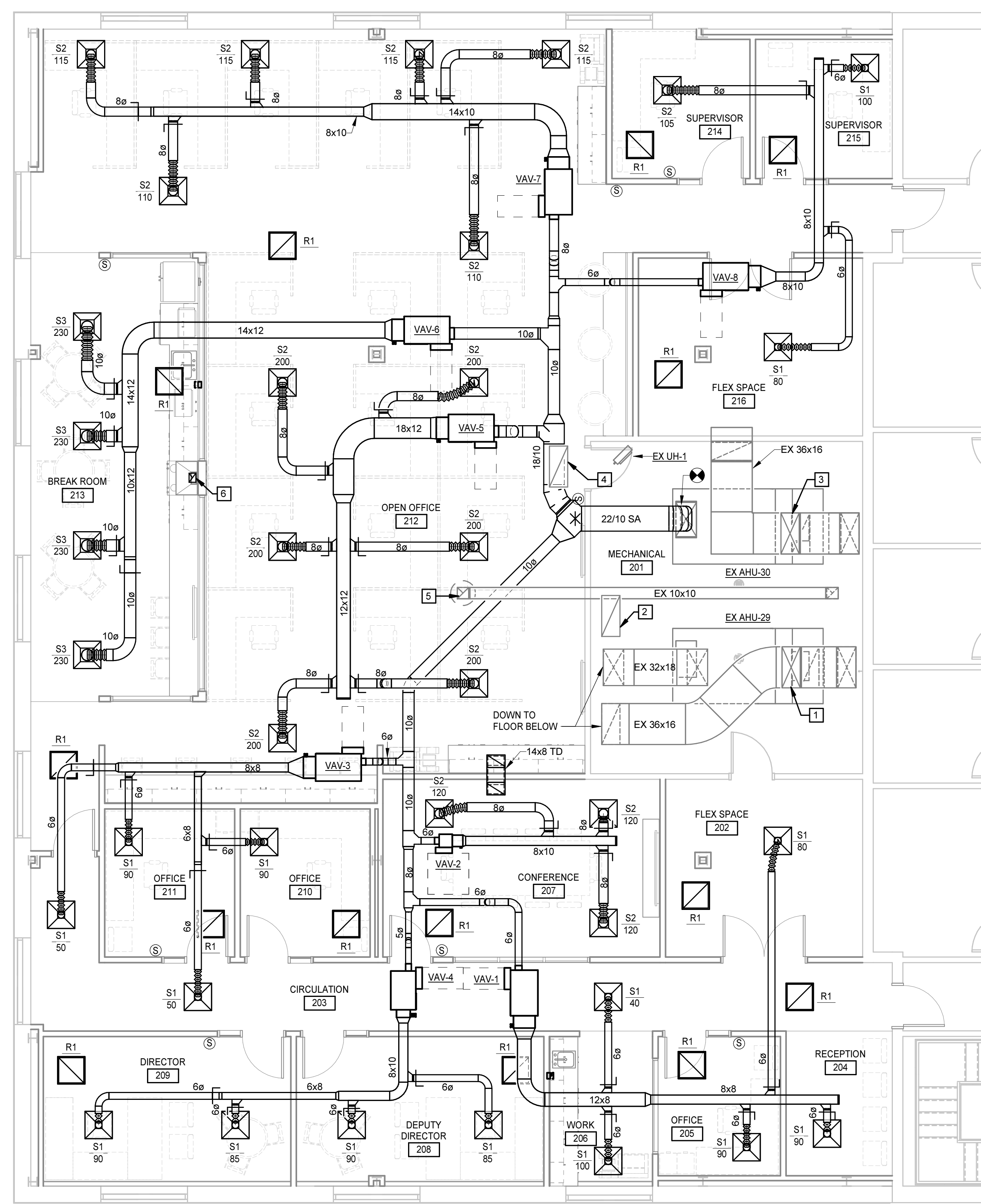

**SECOND FLOOR PLAN - DUCTWORK**  
 3/16" = 1'-0"

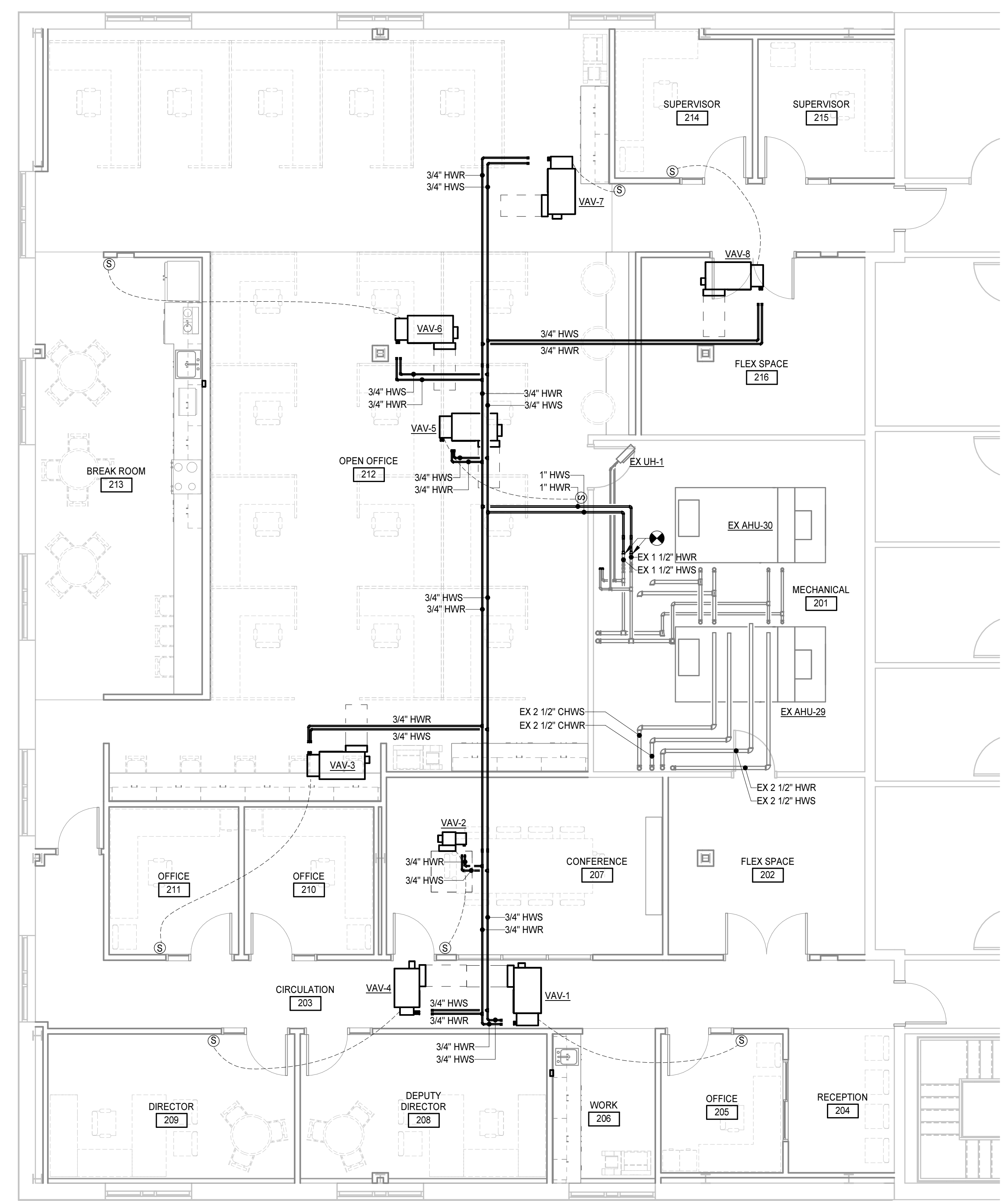

**SECOND FLOOR PLAN - PIPING**  
 3/16" = 1'-0"

**HARNETT CO DSS UPFIT 2ND FLOOR**

631797  
**HARNETT CO DSS**  
 311 W CORNELIUS HARNETT BLVD, LILLINGTON, NC 27546

PROJECT NO:	631797
DATE:	FEBRUARY 7, 2024
REVISIONS	
DATE	DESCRIPTION

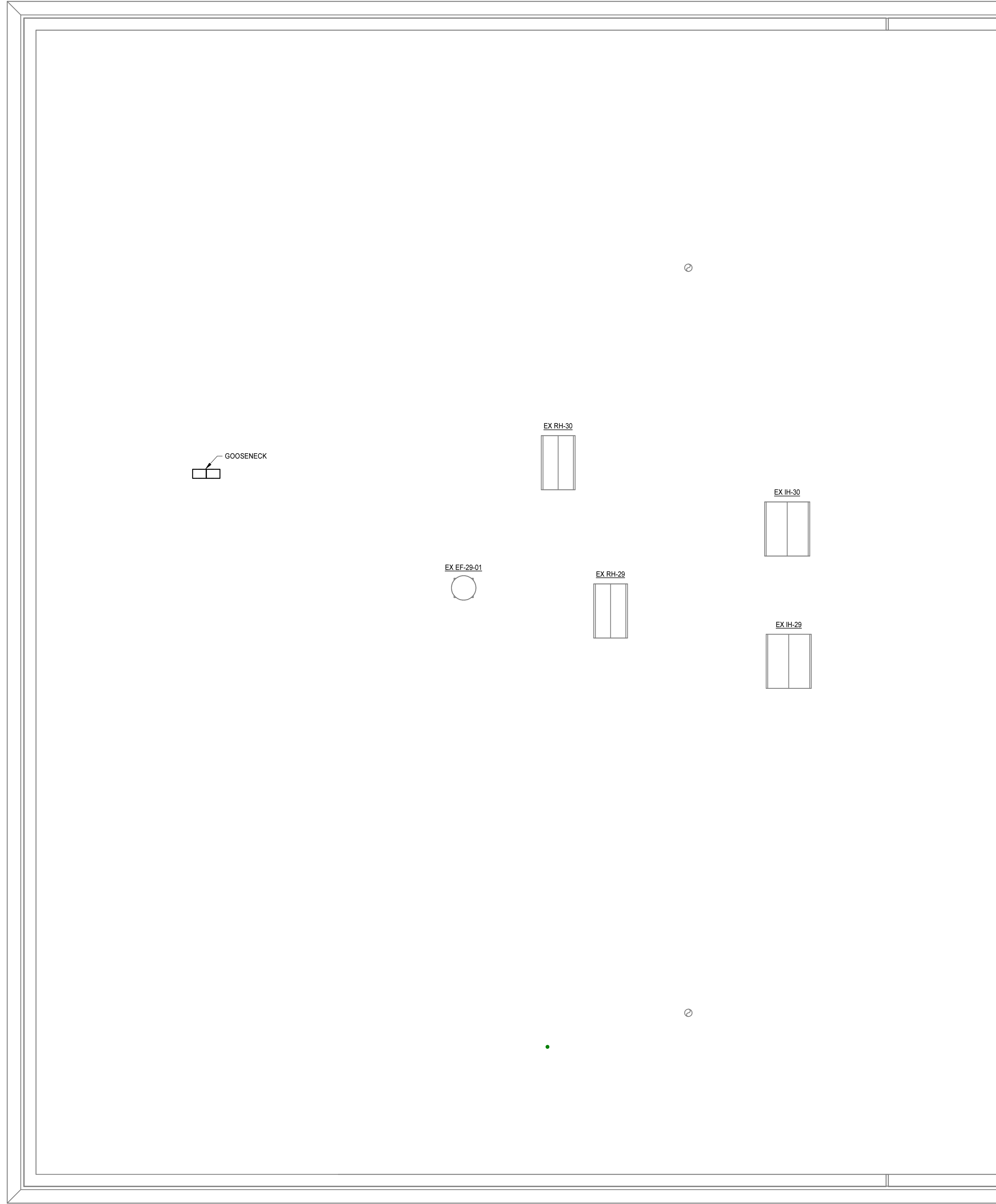

**ROOF PLAN**  
 1/4" = 1'-0"

PROJECT NO.	631797
DATE	FEBRUARY 7, 2024
REVISIONS	
DATE	DESCRIPTION

**HARNETT CO DSS UPFIT 2ND FLOOR**

631797  
 HARNETT CO DSS  
 311 W CORNELIUS HARNETT BLVD, LILLINGTON, NC 27546



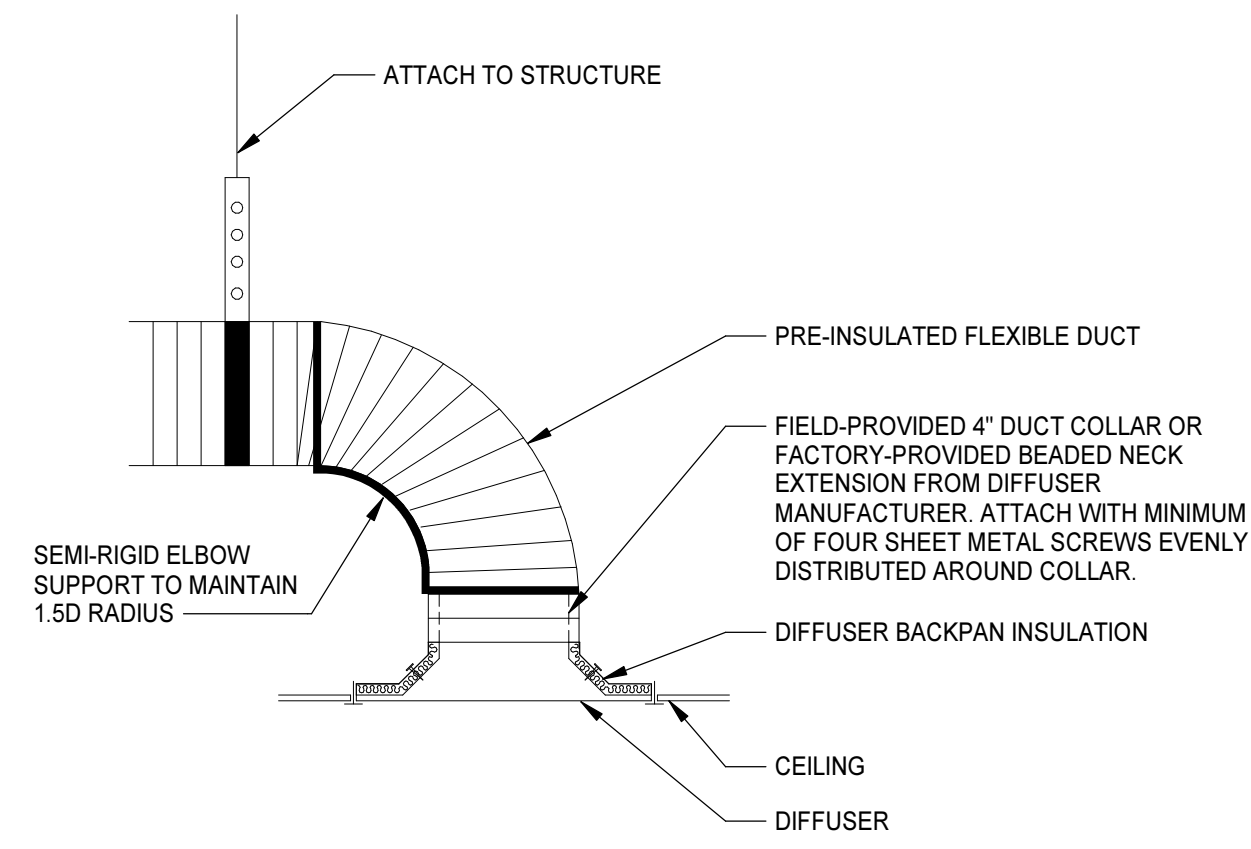

**FLEXIBLE DUCT TO DIFFUSER CONNECTION DETAIL**

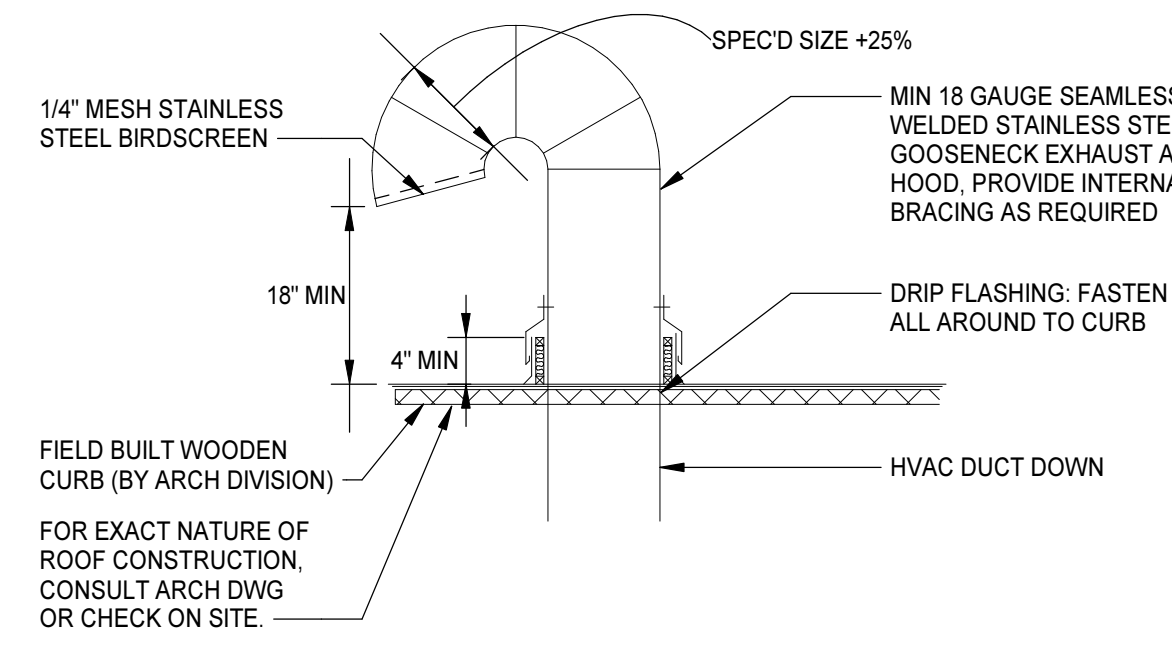

**GOOSENECK DETAIL**

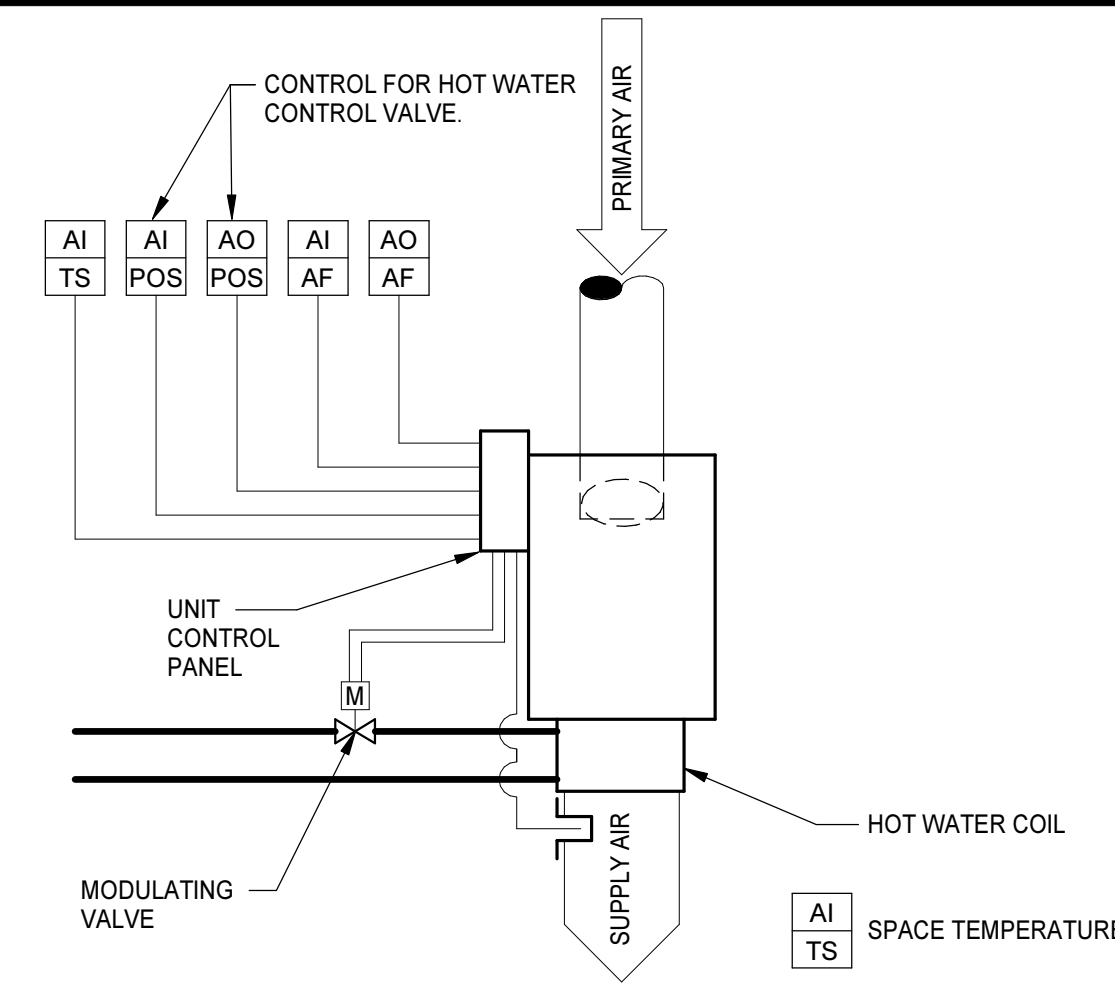

**TERMINAL UNIT WITH MODULATING CONTROL OF HOT WATER HEAT**

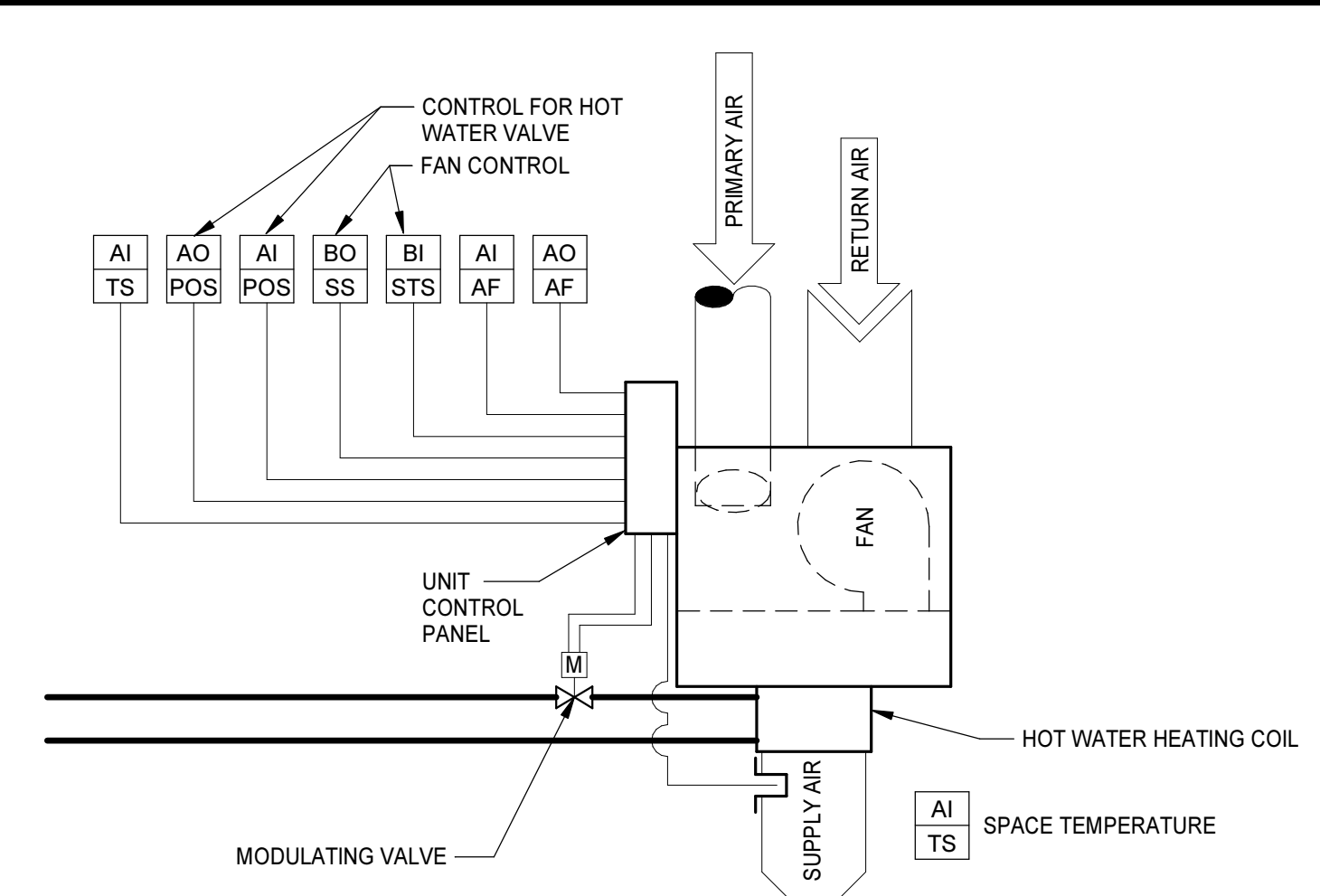

**SERIES FAN POWERED TERMINAL UNIT WITH MODULATING HOT WATER HEATING COIL**



**OPEN END DUCT DETAIL**

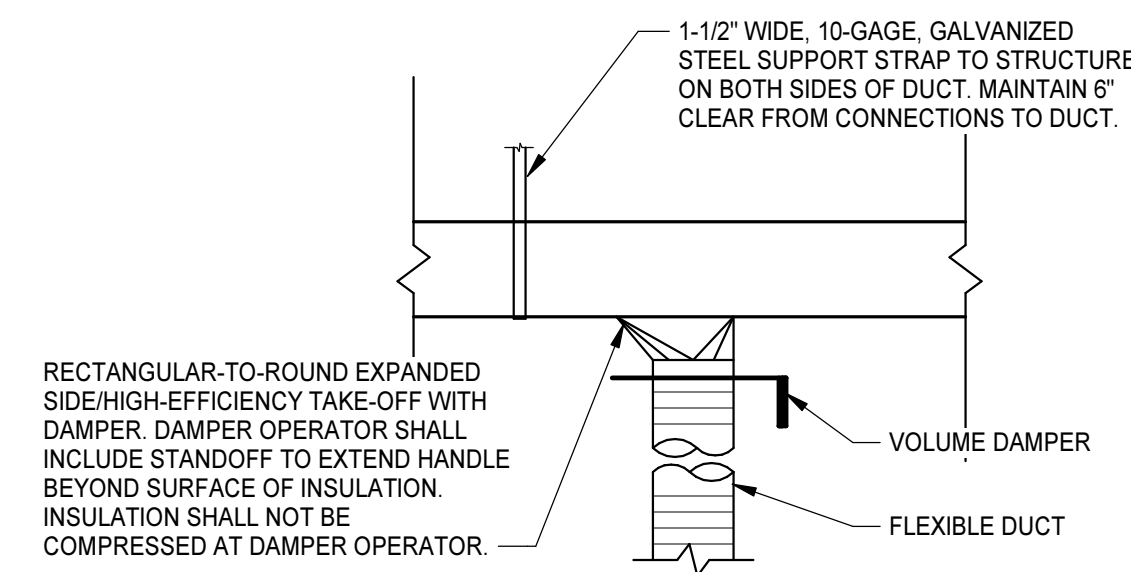

- NOTES:**
1. FLEXIBLE DUCT SHALL BE INSTALLED OVER METAL DUCT (BEAD UP ON METAL DUCT) AND ANCHORED WITH NYLON MECHANICAL BANDS OR PANDUIT STRAP.
  2. IN EXPOSED AREAS, PROVIDE RIGID GALVANIZED STEEL BRANCH DUCT TO DIFFUSERS IN LIEU OF FLEXIBLE DUCT UNLESS INDICATED OTHERWISE. SUPPORT IN ACCORDANCE WITH REQUIREMENTS SPECIFIED FOR METAL DUCTS.

**BRANCH CONNECTION TO DIFFUSER DETAILS**

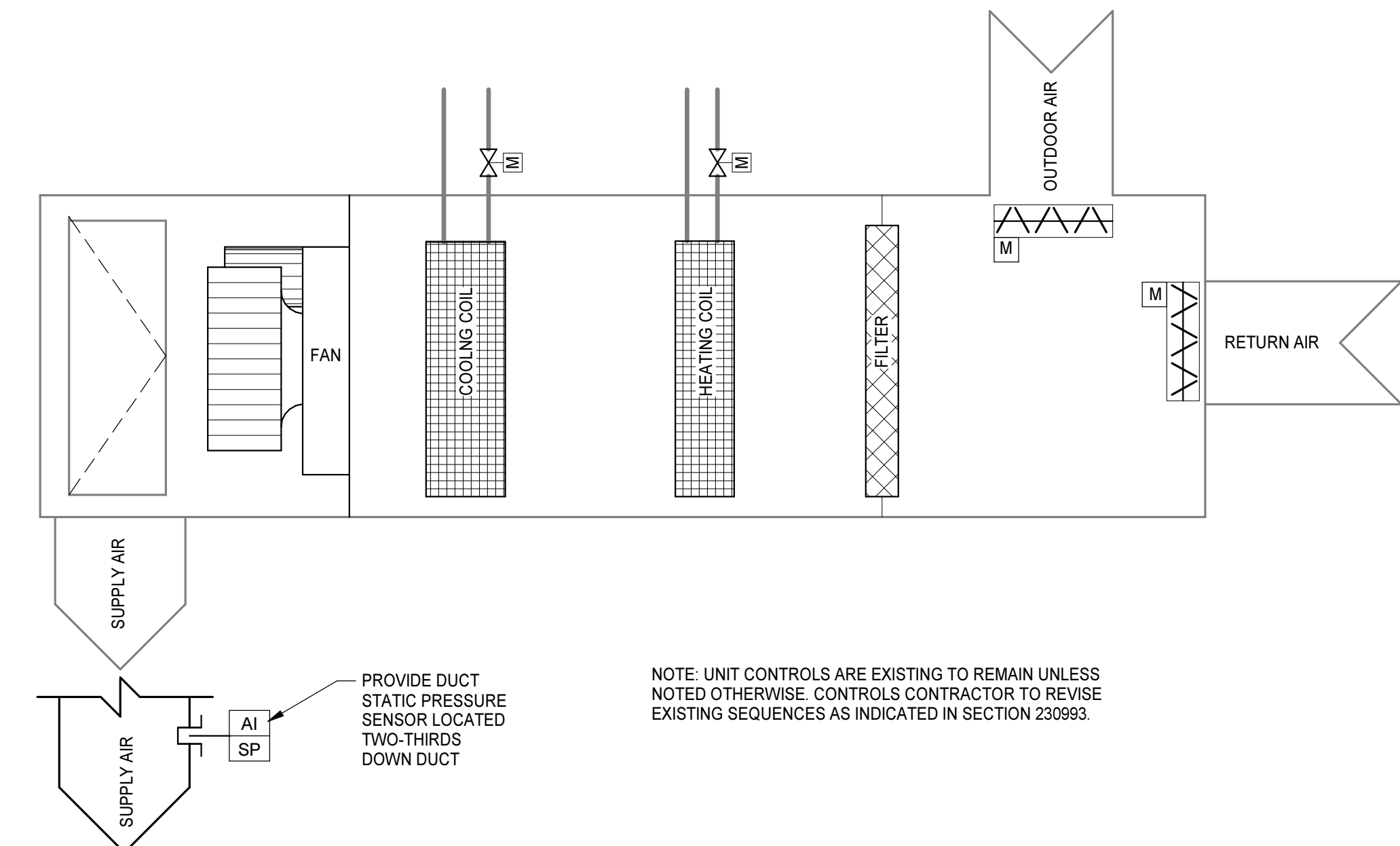
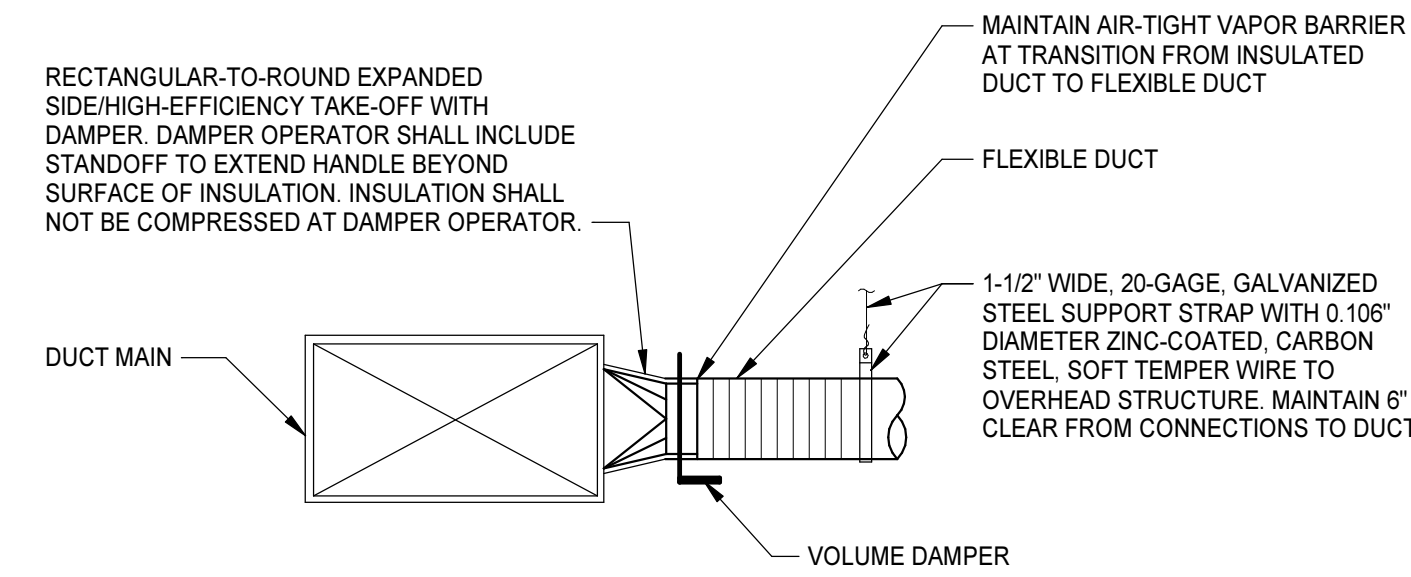

**EX AHU-30 CONTROLS**

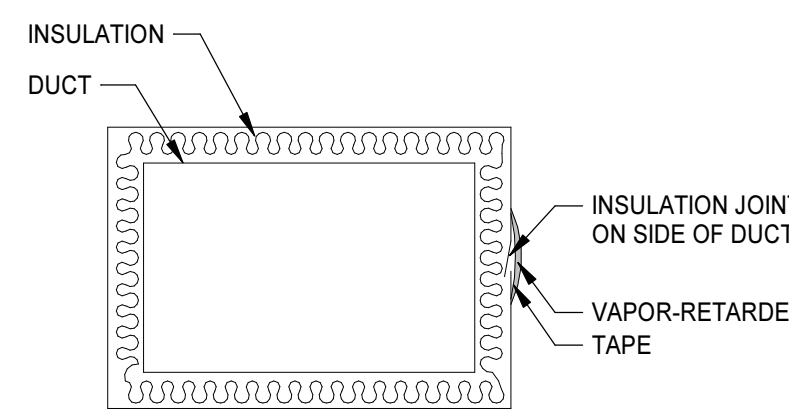

REFER TO SPECIFICATION SECTION 230700 FOR ADDITIONAL INFORMATION.

**DUCT INSULATION JOINT DETAIL**

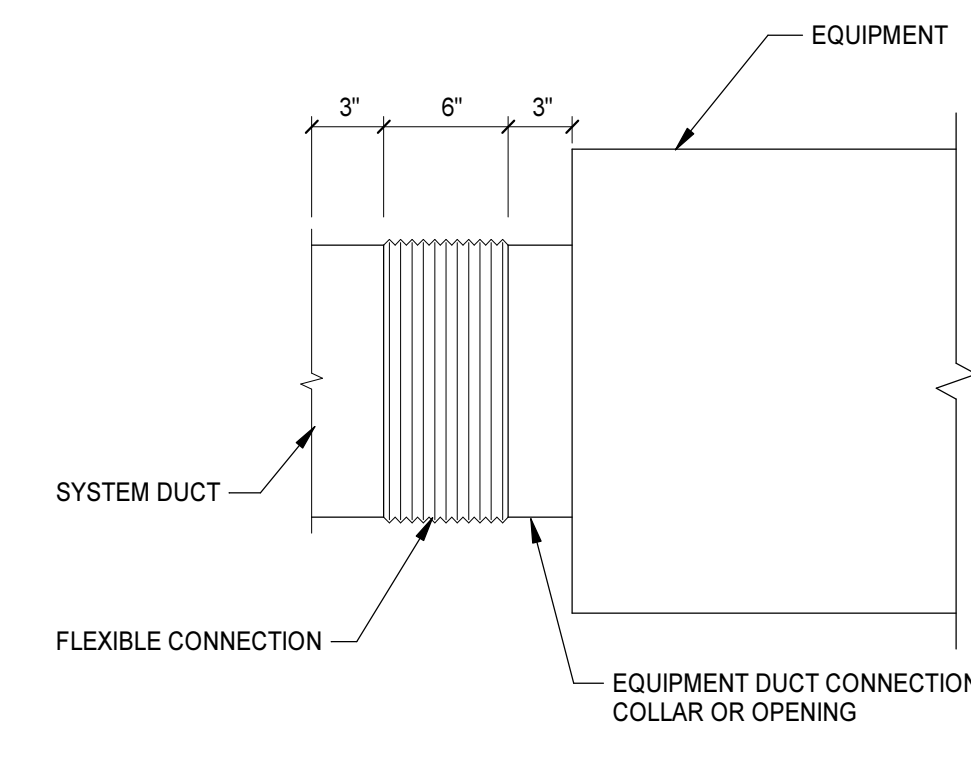

NOTE: THIS DETAIL APPLIES TO ALL DUCT CONNECTIONS TO AIR HANDLING UNITS AND FANS UNLESS OTHERWISE INDICATED.

**EQUIPMENT DUCT CONNECTION DETAIL**

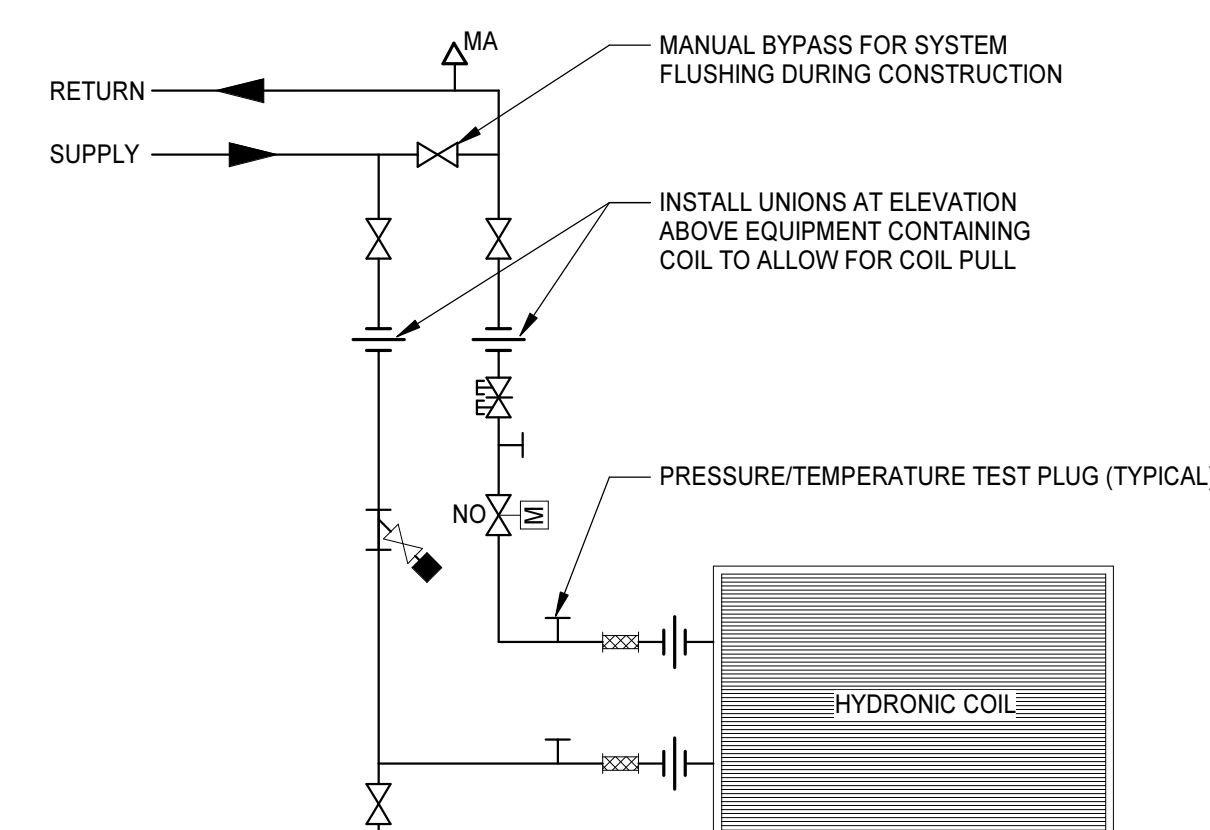

**HYDRONIC COIL PIPING DIAGRAM - TERMINAL EQUIPMENT**

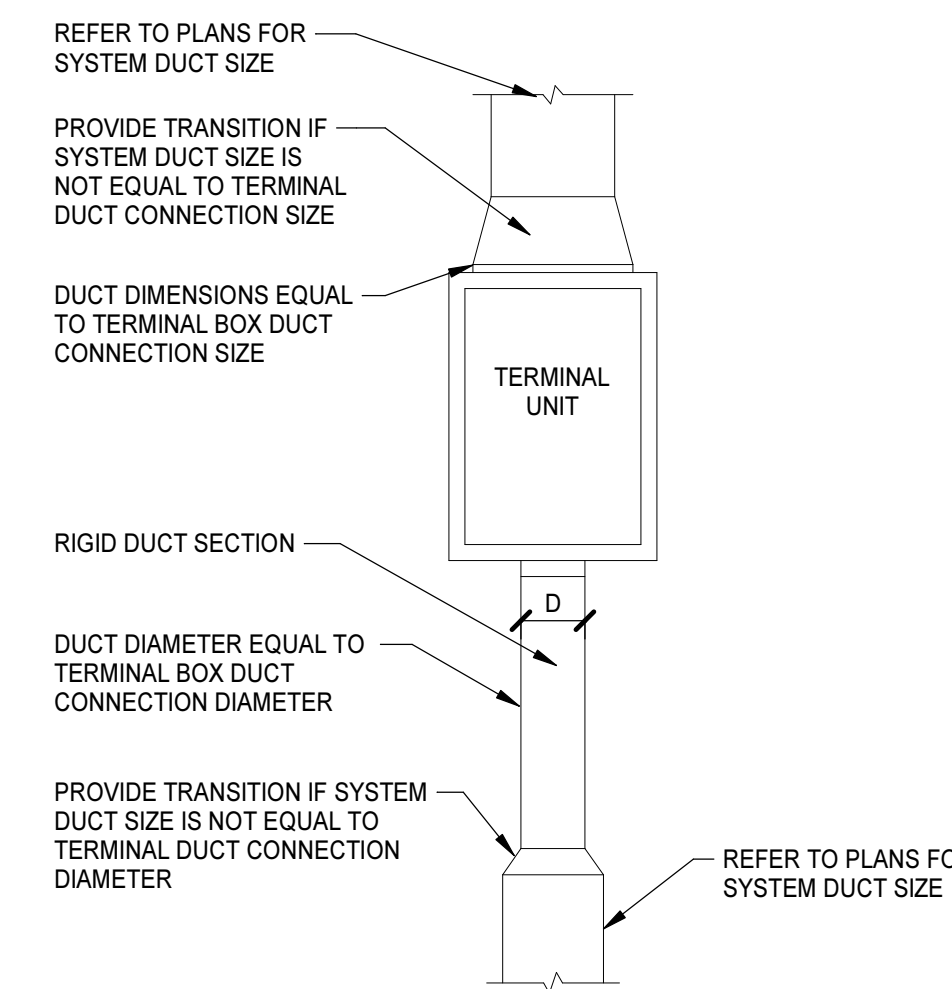

**TERMINAL DUCT CONNECTION DETAIL**

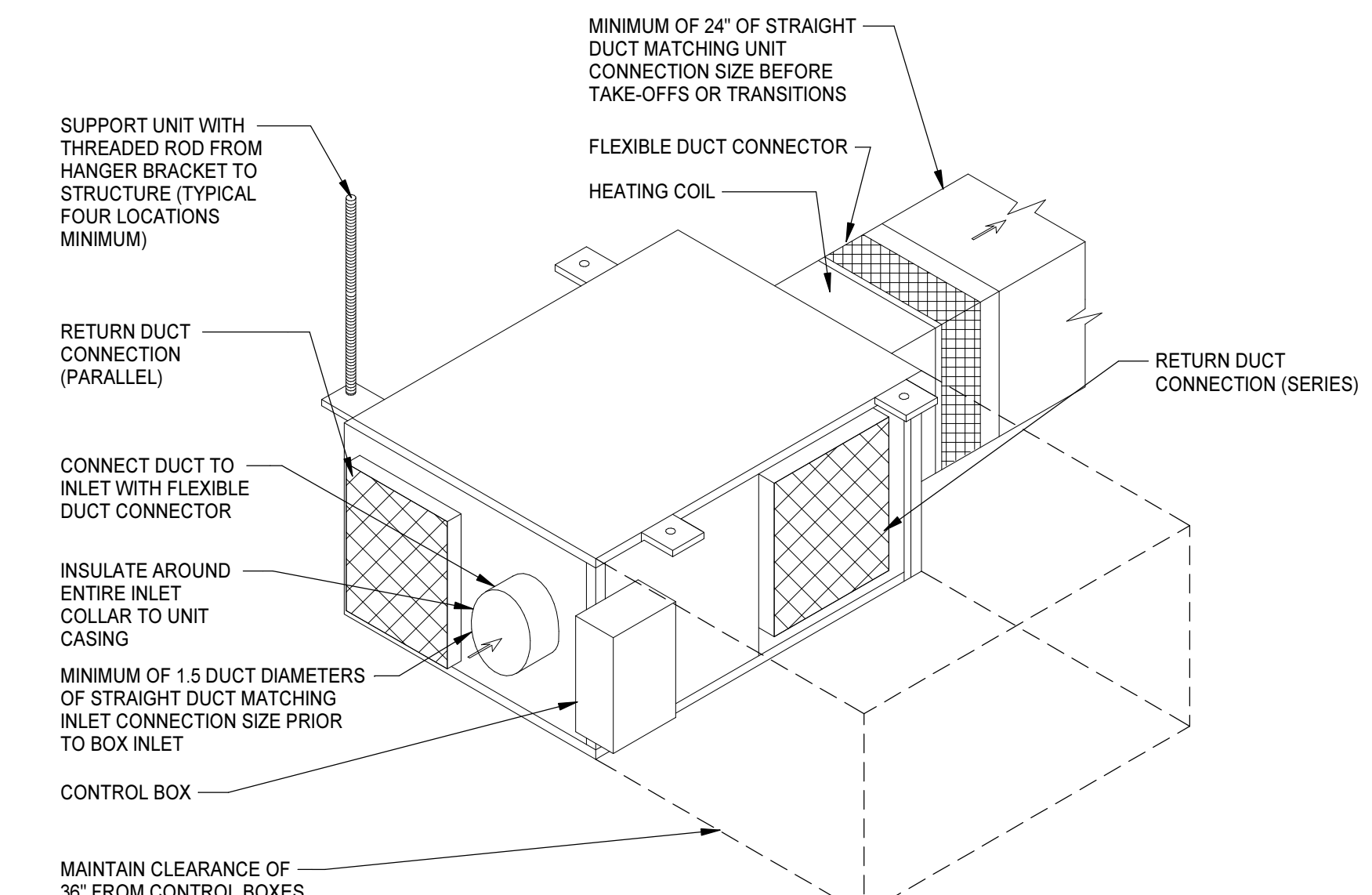

**FAN-POWERED VAV TERMINAL UNIT DETAIL**

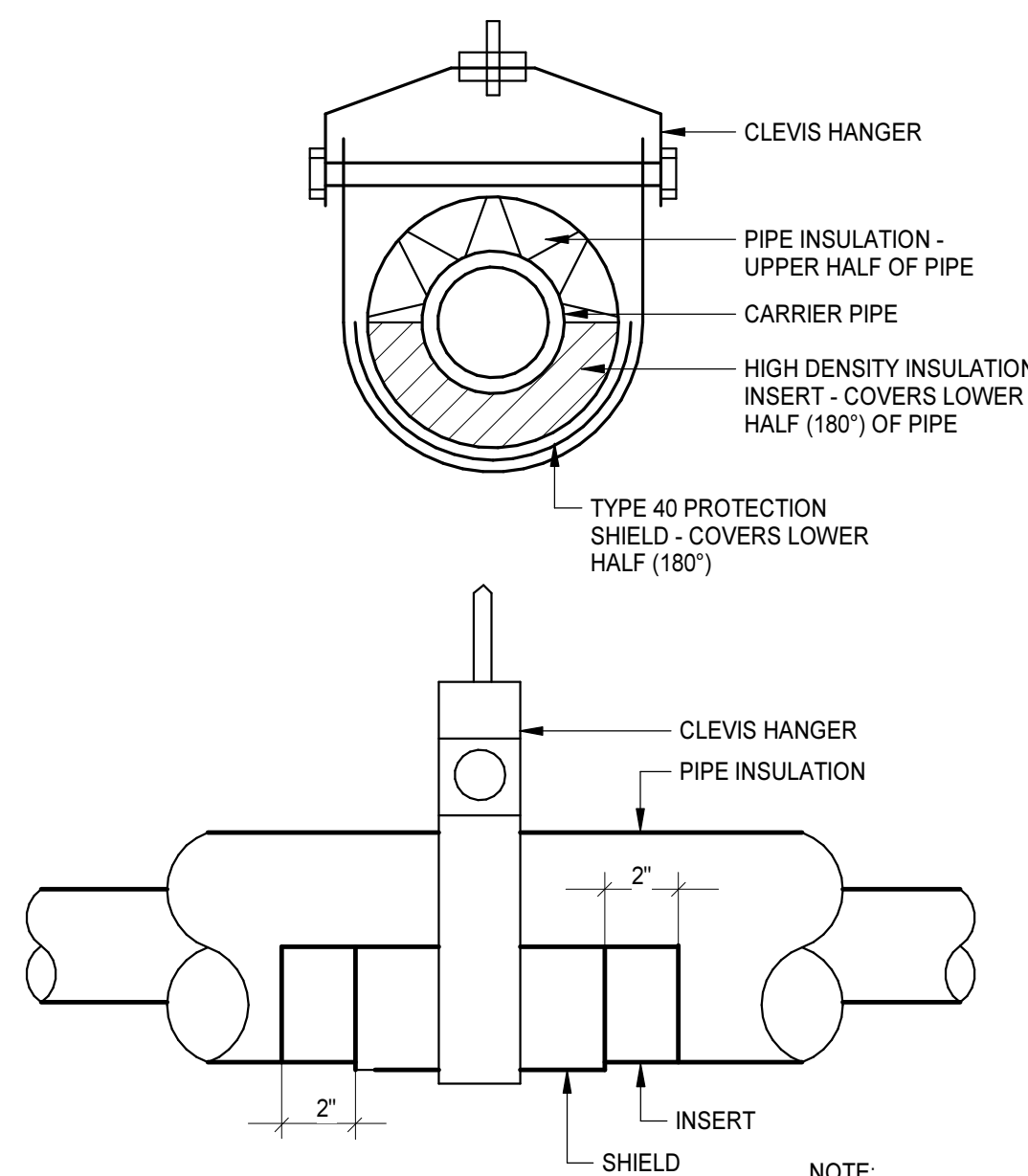

**CLEVIS OR BAND HANGER**

NOTE:  
1. FOR COLD PIPE MAINTAIN INTEGRITY OF VAPOR BARRIER AT SEAM BETWEEN INSERT AND PIPE INSULATION.

**PIPE SUPPORT AND THERMAL SHIELD DETAILS**

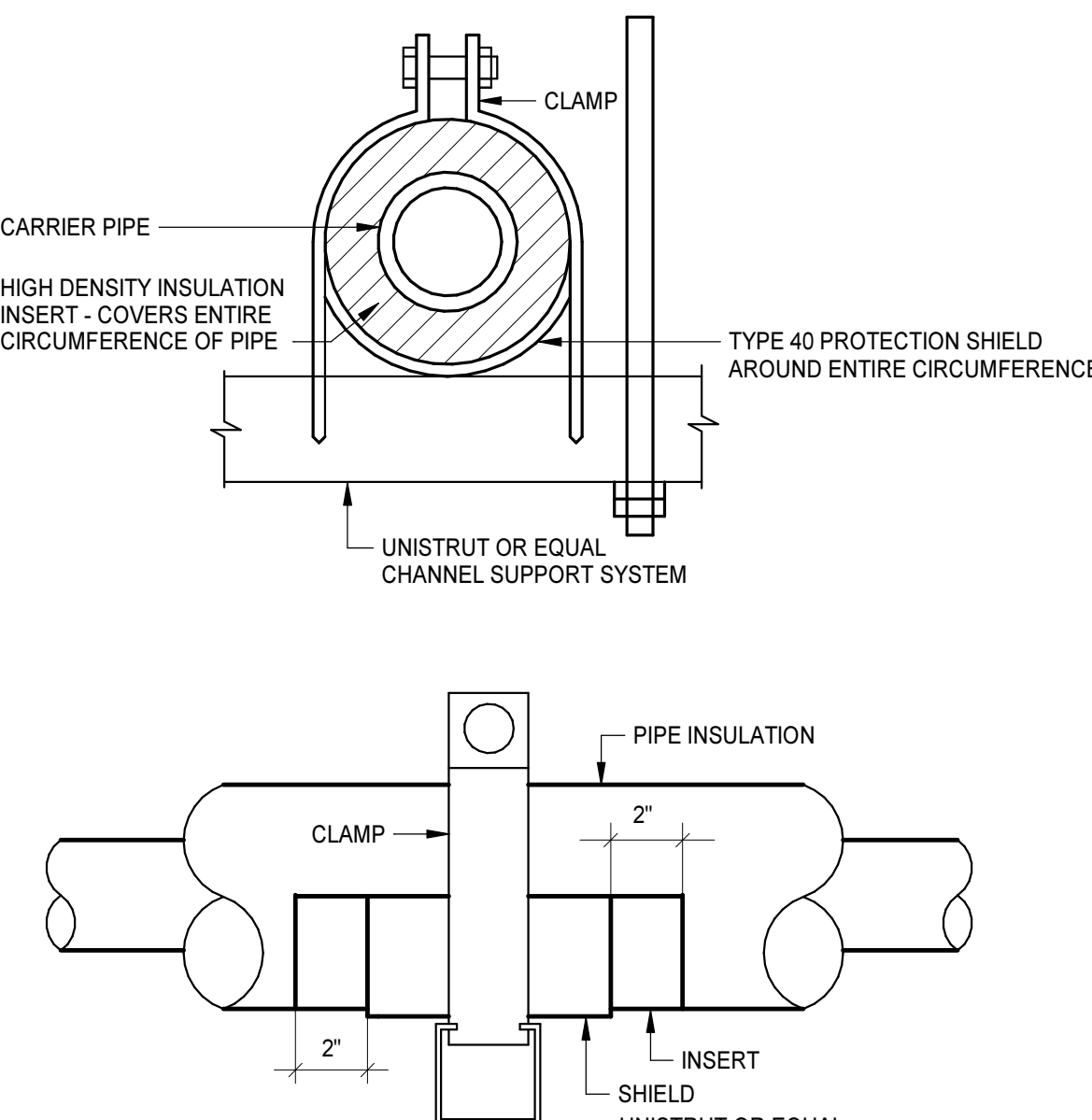

**TRAPEZE OR CLAMPED SYSTEM**

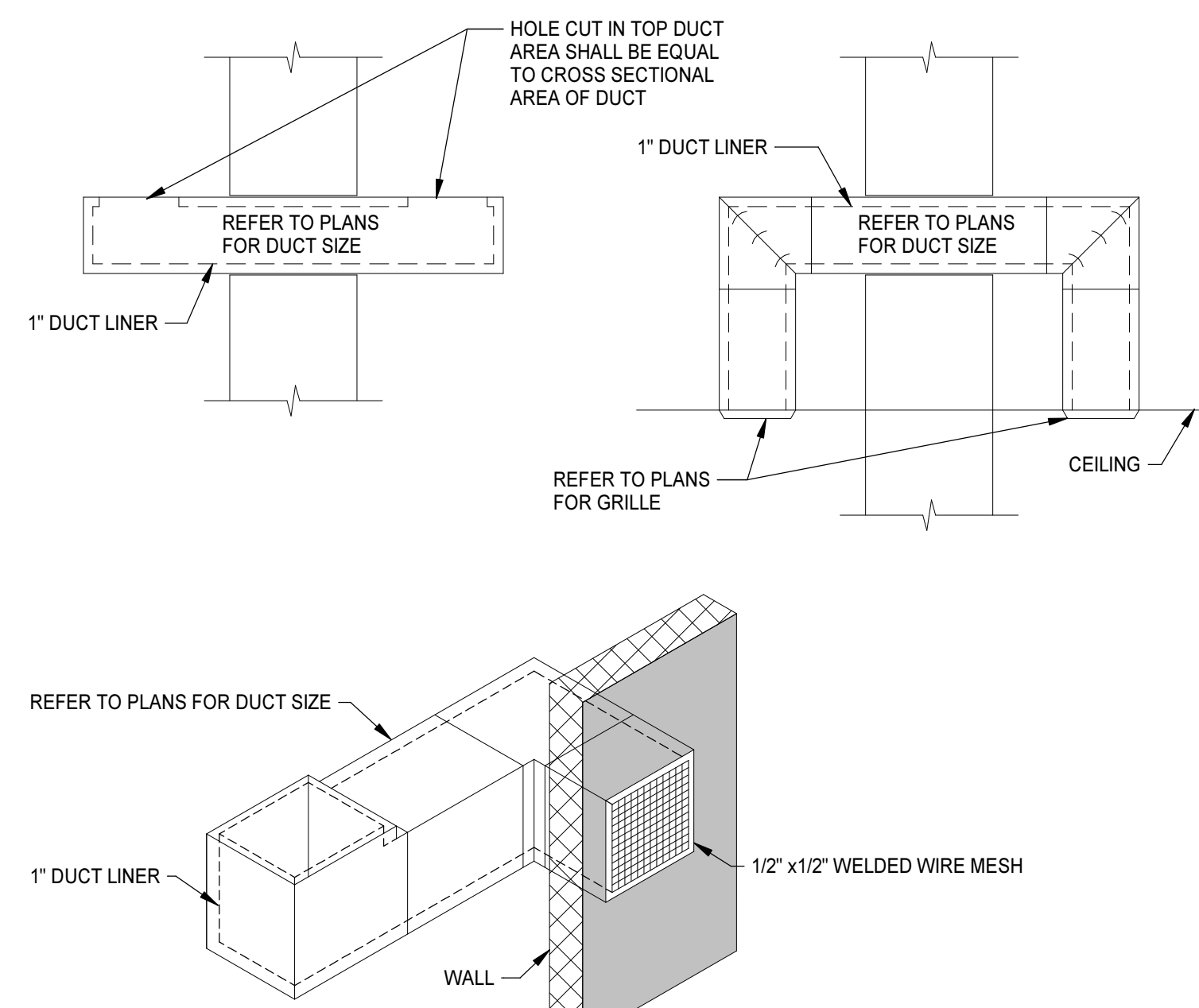

**TRANSFER DUCT DETAIL**

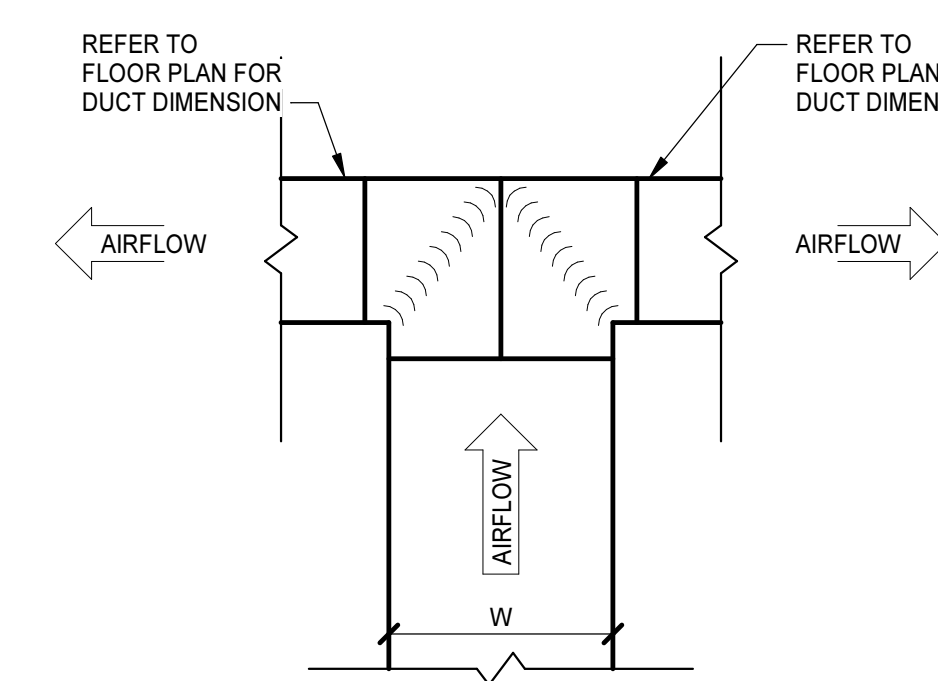

**NOTES:**  
1. APPLIES WHERE "W" EXCEEDS 24" OR WHEN AIRFLOW EXCEEDS 1,500 CFM.

**DIVIDED FLOW BRANCH DETAILS**

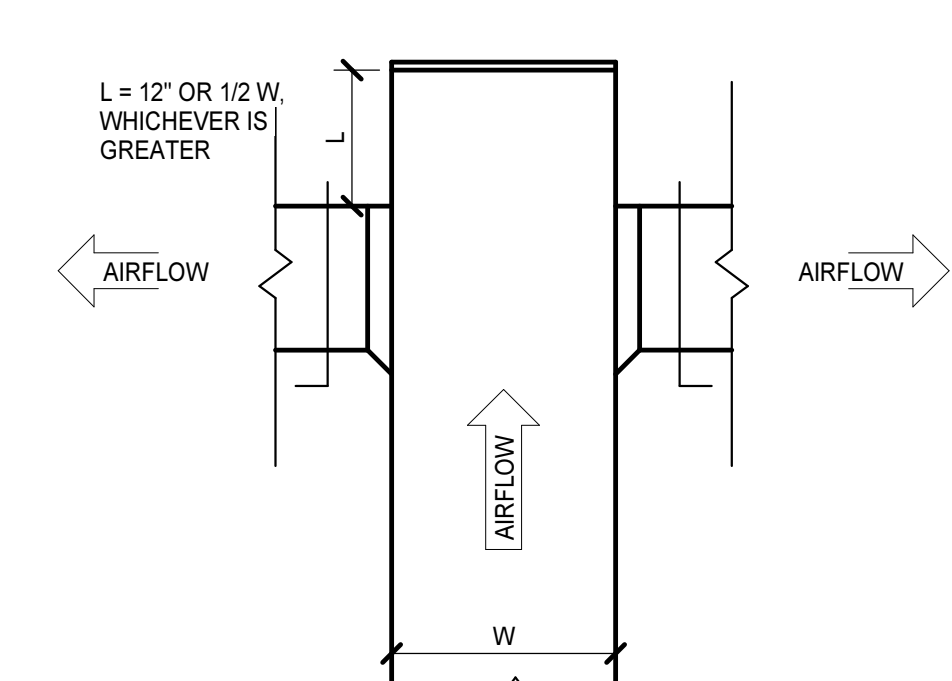

**NOTES:**  
1. REFER TO BRANCH CONNECTION TO DIFFUSER DETAILS FOR BRANCH TAKE-OFF REQUIREMENTS.  
2. APPLIES TO:  
A. WHERE "W" IS LESS THAN 24"  
B. ROUND DUCT BRANCHES TO DIFFUSERS  
C. WHEN AIRFLOW IS EQUAL TO OR LESS THAN 1,500 CFM.



PROJECT NO:	631797
DATE:	FEBRUARY 7, 2024
REVISIONS	
DATE	DESCRIPTION

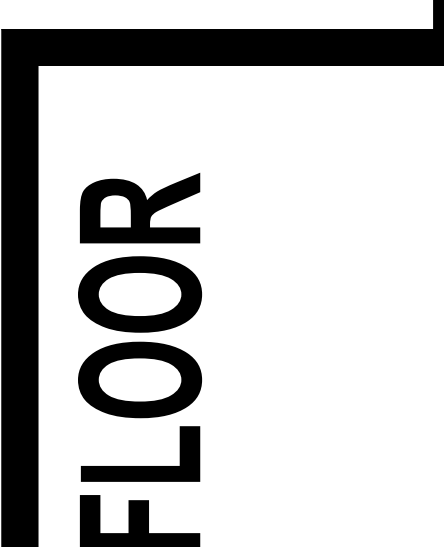

Table with 2 columns: REVISIONS, DESCRIPTION. Includes revision 1 for 'REVISIONS' and revision 2 for 'DESCRIPTION'.

GENERAL NOTES

- A. THE CONTRACT DOCUMENTS ARE COMPLEMENTARY AND WHAT IS REQUIRED BY ONE SHALL BE AS BINDING AS IF REQUIRED BY ALL...
B. FOLLOW MOUNTING HEIGHTS INDICATED IN THE ELECTRICAL LEGEND UNLESS OTHERWISE INDICATED...
C. FIELD VERIFY EXACT FEEDER LOCATIONS FOR MECHANICAL EQUIPMENT PRIOR TO ROUGH-IN...
D. EQUIPMENT CONNECTIONS ARE INDICATED IN THEIR APPROXIMATE LOCATIONS...
E. LOCATED ALL SWITCHES FOR LOCAL CONTROL OF LIGHTING ON STRIKE SIDE OF SINGLE DOORS UNLESS OTHERWISE INDICATED...
F. PROVIDE SPECIFIC BREAKER ARRANGEMENT FOR THE PANEL BOARDS...
G. PROVIDE AS-BUILT DRAWINGS INDICATING ACTUAL BRANCH CIRCUIT ARRANGEMENT...
H. ALL CONDUIT RUNS INDICATED ARE DIAGRAMMATIC...
I. ALL PANELBOARDS INDICATED ARE HOUSED IN A SINGLE WIDTH ENCLOSURE...
J. WHERE POWER AND COMMUNICATION OUTLETS ARE INDICATED IN CLOSE PROXIMITY...
K. ALL EXTERIOR RECEPTACLES SHALL BE LABELED 'WR' - WEATHER RESISTANT...
L. WHEN GROUPING MULTIPLE LINE TO NEUTRAL BRANCH CIRCUITS IN A CONDUIT...
M. PROVIDE A 2" WIDE YELLOW LINE PAINTED ON THE FLOOR...
N. REFER TO STRUCTURAL DRAWINGS FOR ALL CONDUIT REQUIREMENTS...

ABBREVIATIONS

Table listing abbreviations and their meanings, such as 1P SINGLE PHASE, 3P THREE PHASE, A WEATHERPROOF (NEMA 3R), AF AMP, AFF ABOVE FINISHED FLOOR, AL ALUMINUM, etc.

LIGHTING LEGEND

Table with columns SYMBOL and DESCRIPTION for lighting devices, including light switches, dimmer switches, occupancy detectors, and various light fixtures.

COMMUNICATIONS LEGEND

Table with columns SYMBOL and DESCRIPTION for communication devices, including telecommunication outlets, microphone inputs, audio inputs, and ground bus bars.

FIRE ALARM LEGEND

Table with columns SYMBOL and DESCRIPTION for fire alarm devices, including notification devices, detectors, control modules, and sprinkler bells.

POWER / COMMUNICATION DEVICE LEGEND

Table with columns SYMBOL and DESCRIPTION for power and communication devices, including floor boxes, power poles, and video projectors.

ONE LINE DIAGRAM LEGEND

Table with columns SYMBOL and DESCRIPTION for one-line diagram symbols, including circuit breakers, fuses, transformers, and transfer switches.

POWER DEVICE / EQUIPMENT LEGEND

Table with columns SYMBOL and DESCRIPTION for power devices and equipment, including door controllers, switches, disconnects, and motor starters.

RECEPTACLE DEVICE LEGEND

Table with columns SYMBOL and DESCRIPTION for receptacle devices, including duplex, GFCI, and switched duplex receptacles.

GRAPHICS SYMBOLS LEGEND

Table with columns SYMBOL and DESCRIPTION for graphics symbols, including space identification tags, section where cut, enlarged plan where cut, detail tag, detail title, and section title.

DEMOLITION LEGEND

Table with columns SYMBOL and DESCRIPTION for demolition symbols, including devices to be removed and existing devices.

GENERAL DEMOLITION NOTES

- A. PROVIDE ALL ELECTRICAL DEMOLITION WORK REQUIRED TO INSTALL THE WORK INDICATED...
B. REMOVE ALL EXISTING CONDUITS THAT WILL NOT BE REUSED...
C. MAINTAIN CONTINUITY OF ALL EXISTING CIRCUITS...
D. BEFORE DEMOLITION, VERIFY WITH THE OWNER ALL EQUIPMENT TO BE SALVAGED...
E. EXERCISE CARE IN REMOVING DEMOLITION ITEMS...
G. WHERE DEMOLITION OF TELECOMMUNICATIONS DEVICES OCCUR...
H. DEMOLITION FLOOR PLANS ARE PROVIDED FOR REFERENCE ONLY...

1 OVERALL FLOOR PLAN  
1/8" = 1'-0"

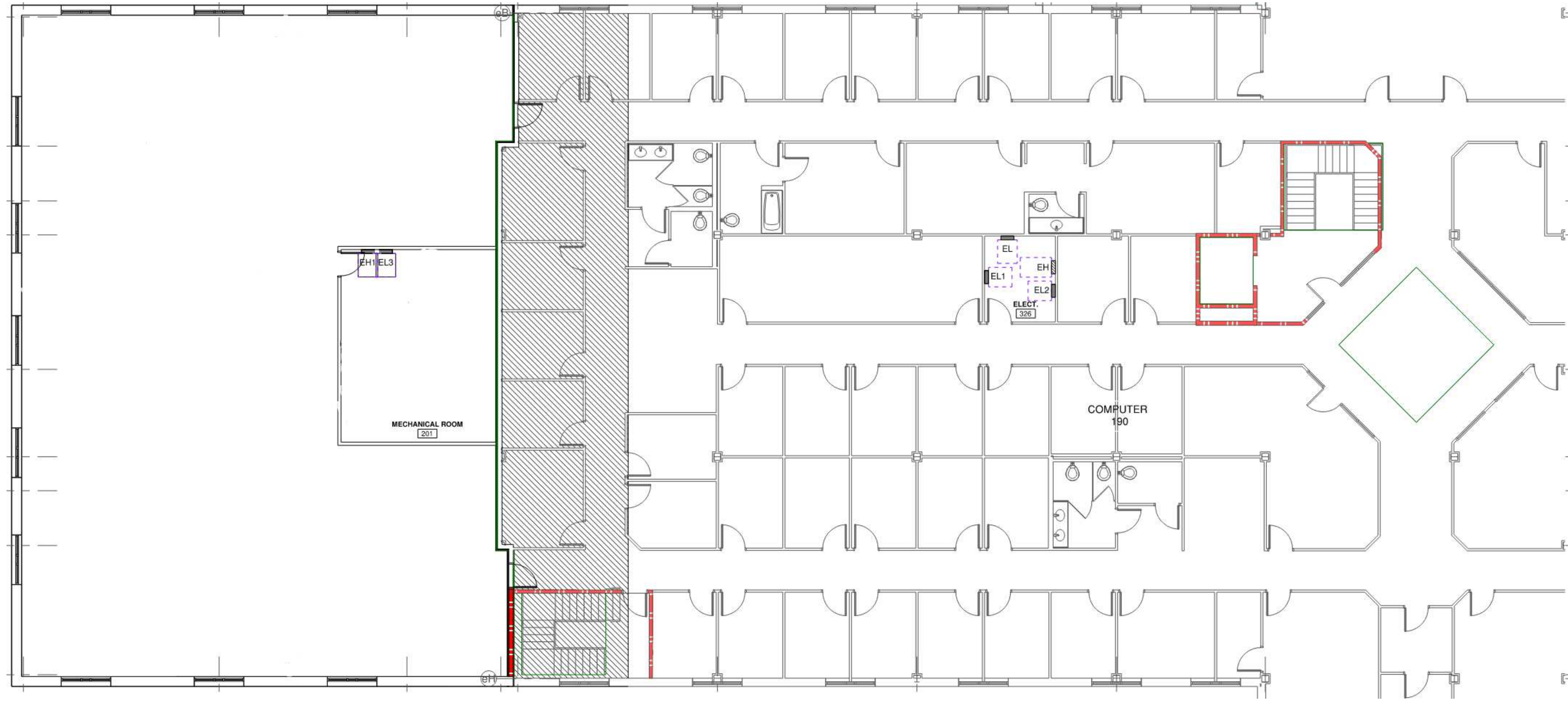

ELECTRICAL OVERALL PLAN

PROJECT NO.	631797
DATE	FEBRUARY 7, 2024
REVISIONS	
DATE	DESCRIPTION

**HARNETT CO DSS UPFIT 2ND FLOOR**  
 631797  
 HARNETT CO DSS  
 311 W CORNELIUS HARNETT BLVD, LILLINGTON, NC 27546

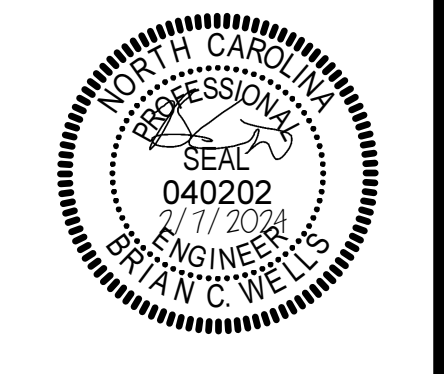
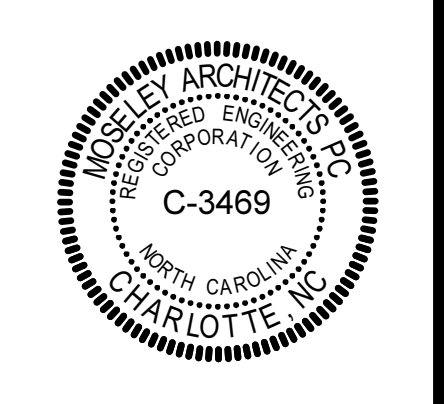

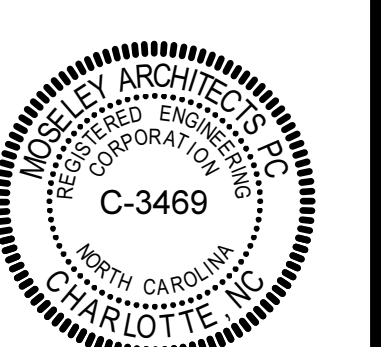
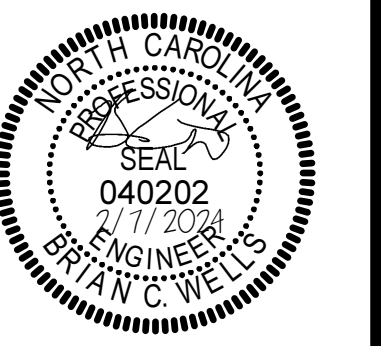

**GENERAL NOTES**

1. PROVIDE FIRE ALARM DEVICES AS SHOWN AND CONNECT TO EXISTING SIMPLEX 4020 FIRE ALARM SYSTEM.
2. PROVIDE 2" EMT CONDUIT SLEEVE WITH NYLON BUSHING EACH END UNO WHERE REQUIRED FOR THRU WALL PENETRATION AT +5' ABOVE FINISHED CEILING.

**KEYNOTES**  
 APPLIES TO THIS DRAWING

1. MOUNTED IN MILLWORK. COORDINATE MOUNTING HEIGHT WITH ARCHITECTURAL DRAWINGS.
2. DISCONNECT & REMOVE ALL LIGHT FIXTURES, SWITCHING & SWITCH LEGS IN THIS ROOM. MAINTAIN BRANCH CIRCUIT HOME-RUN FOR REUSE.
3. DISCONNECT & REMOVE EXISTING FIRE ALARM NOTIFICATION DEVICE.
4. COORDINATE MOUNTING HEIGHT AND LENGTH OF FIXTURE WITH ARCHITECTURAL DRAWINGS FOR UNDER CABINET LIGHTING.
5. LOCATE LV TRANSFORMER FOR UNDER CABINET LIGHTING ABOVE ACCESSIBLE CEILING & PROVIDE ALL WIRING & ACCESSORIES AS REQUIRED FOR A COMPLETE INSTALLATION.
6. COORDINATE HEIGHT OF RECEPTACLE WITH MICROWAVE ON ARCHITECTURAL DRAWINGS.

**DIV 23 ELECTRICAL CONNECTION SCHEDULE**

TAG	VOLTAGE	# POLES	LOAD	PANEL	CCT#	WIRE	DISCONNECTING MEANS	REMARKS
EWH-1	277 V	1	4.1 KVA	EHI 24	24	(2) #12 (1) #12 E G IN 3/4"	MOTOR RATED SWITCH	
EWH-2	277 V	1	4.1 KVA	EHI 28	28	(2) #12 (1) #12 E G IN 3/4"	MOTOR RATED SWITCH	
VAV-1	277 V	1	0.7 KVA	EHI 18	18	(2) #12 (1) #12 E G IN 3/4"	MOTOR RATED SWITCH	
VAV-2	277 V	1	0.1 KVA	EHI 18	18	(2) #12 (1) #12 E G IN 3/4"	MOTOR RATED SWITCH	
VAV-3	277 V	1	0.7 KVA	EHI 18	18	(2) #12 (1) #12 E G IN 3/4"	MOTOR RATED SWITCH	
VAV-4	277 V	1	0.7 KVA	EHI 18	18	(2) #12 (1) #12 E G IN 3/4"	MOTOR RATED SWITCH	
VAV-5	277 V	1	1.0 KVA	EHI 20	20	(2) #12 (1) #12 E G IN 3/4"	MOTOR RATED SWITCH	
VAV-6	277 V	1	0.7 KVA	EHI 20	20	(2) #12 (1) #12 E G IN 3/4"	MOTOR RATED SWITCH	
VAV-7	277 V	1	0.7 KVA	EHI 20	20	(2) #12 (1) #12 E G IN 3/4"	MOTOR RATED SWITCH	
VAV-8	277 V	1	0.7 KVA	EHI 20	20	(2) #12 (1) #12 E G IN 3/4"	MOTOR RATED SWITCH	

**COPPER FEEDER SCHEDULE**

FEEDER ID	# OF SETS	BUILDING WIRE QUANTITY & SIZE TYPE THHN - DRY TYPE THWN - WET	MINIMUM CONDUIT SIZE	FEEDER ID	# OF SETS	BUILDING WIRE QUANTITY & SIZE TYPE THHN - DRY TYPE THWN - WET	MINIMUM CONDUIT SIZE
30	1	3#10#10 G	3/4"	30Y	1	4#10#10 G	3/4"
35	1	3#8#10 G	3/4"	35Y	1	4#8#10 G	3/4"
40	1	3#8#10 G	3/4"	40Y	1	4#8#10 G	3/4"
45	1	3#8#10 G	1"	45Y	1	4#8#10 G	1"
50	1	3#8#10 G	1"	50Y	1	4#8#10 G	1"
60	1	3#4#8 G	1"	60Y	1	4#4#8 G	1"
70	1	3#4#8 G	1 1/4"	70Y	1	4#4#8 G	1 1/4"
80	1	3#3#8 G	1 1/4"	80Y	1	4#3#8 G	1 1/4"
90	1	3#2#8 G	1 1/4"	90Y	1	4#2#8 G	1 1/4"
100	1	3#1#8 G	1 1/4"	100Y	1	4#1#8 G	1 1/4"

- NOTES:  
 1. ELECTRICAL CONTRACTOR TO VERIFY CONDUIT SIZE REQUIRED IF WIRE TYPES OTHER THAN THOSE LISTED ABOVE ARE USED.  
 2. FEEDER SIZES BASED ON TABLE 310.15(B)(16), 75° C.  
 3. SIZES ADJUSTED PER NEC 110.14.

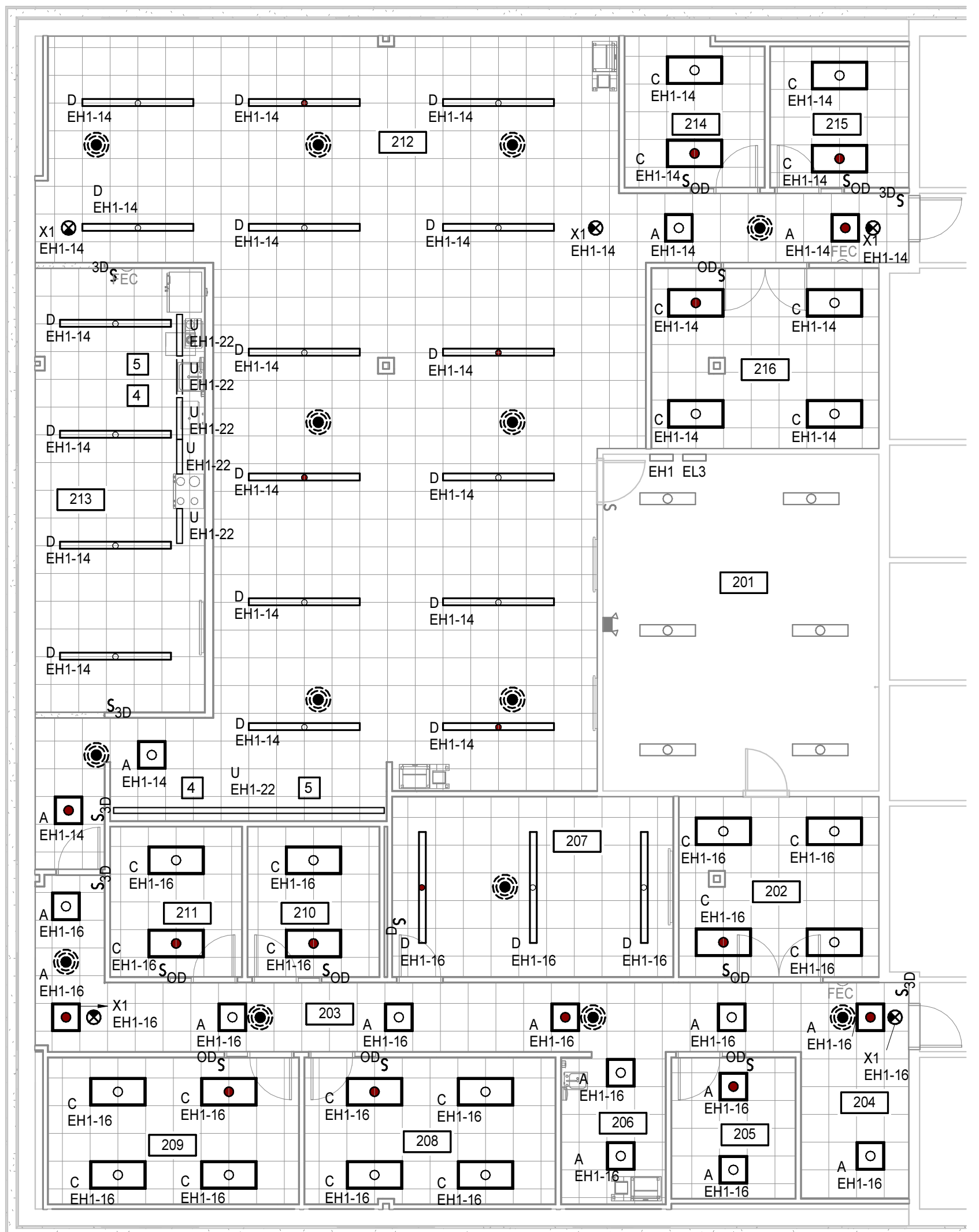

**SECOND FLOOR PLAN - LIGHTING**  
 1/8" = 1'-0"

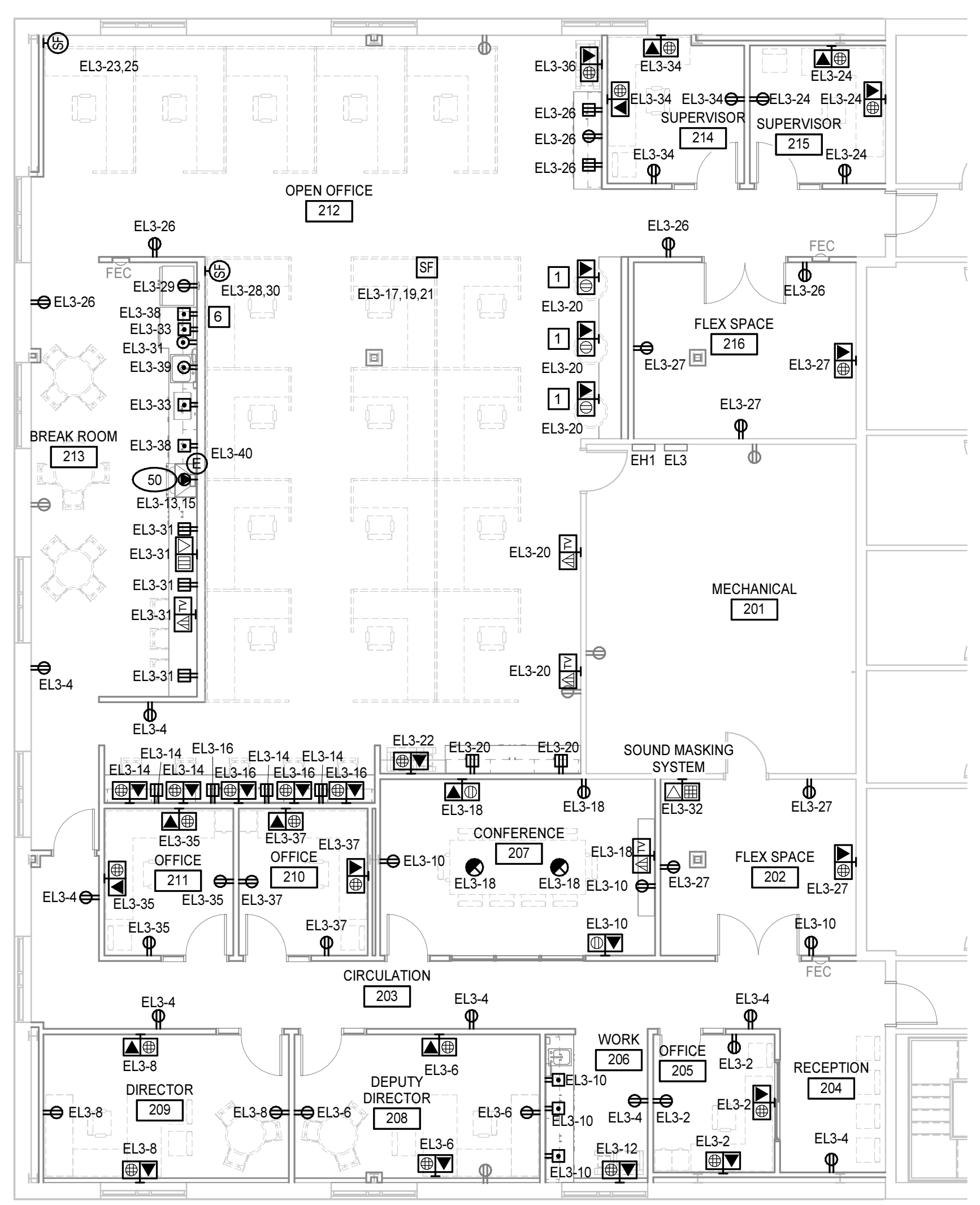

**SECOND FLOOR PLAN - POWER**  
 1/8" = 1'-0"

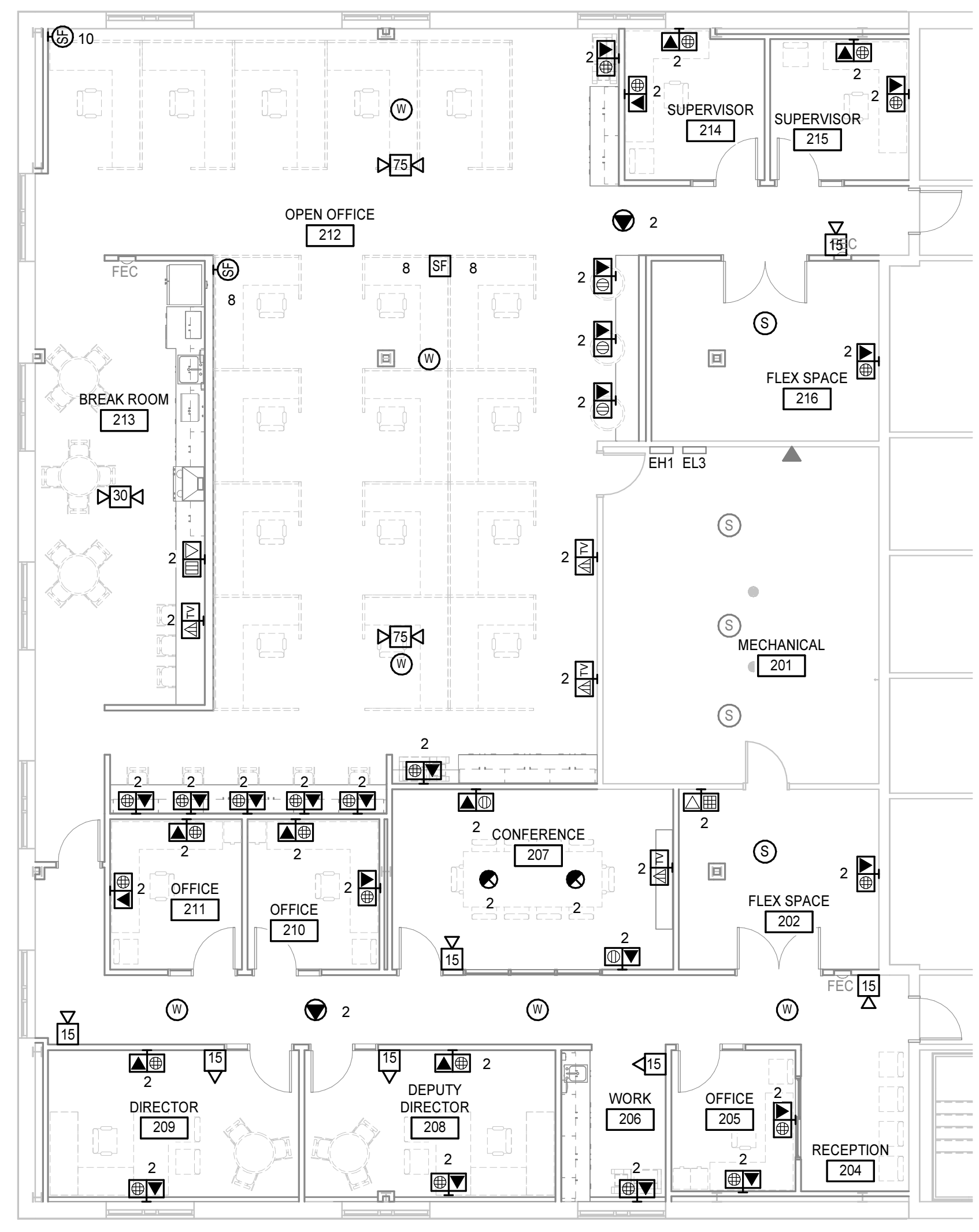

**SECOND FLOOR PLAN - COMMUNICATIONS**  
 1/8" = 1'-0"

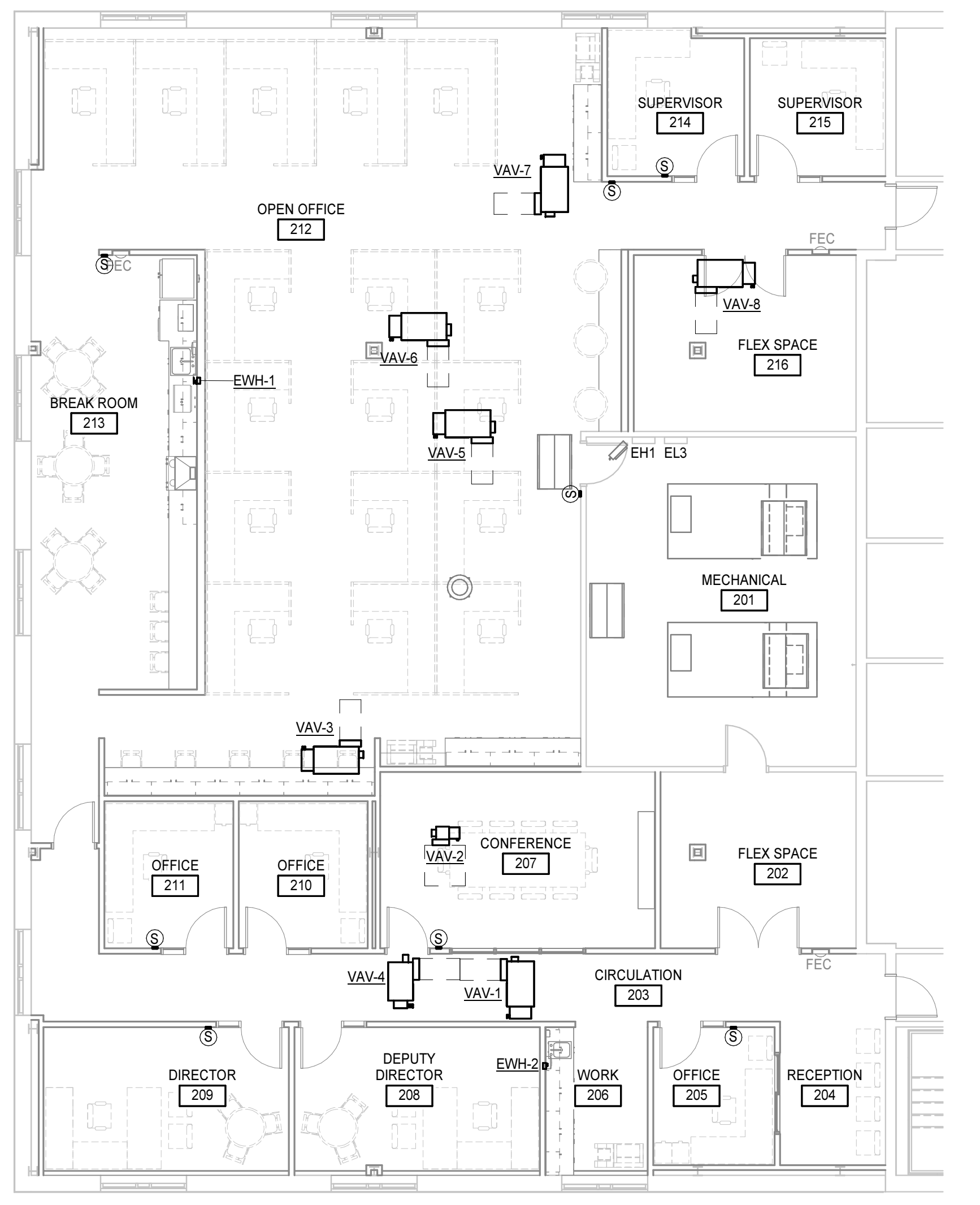

**SECOND FLOOR PLAN - MECHANICAL POWER**  
 1/8" = 1'-0"

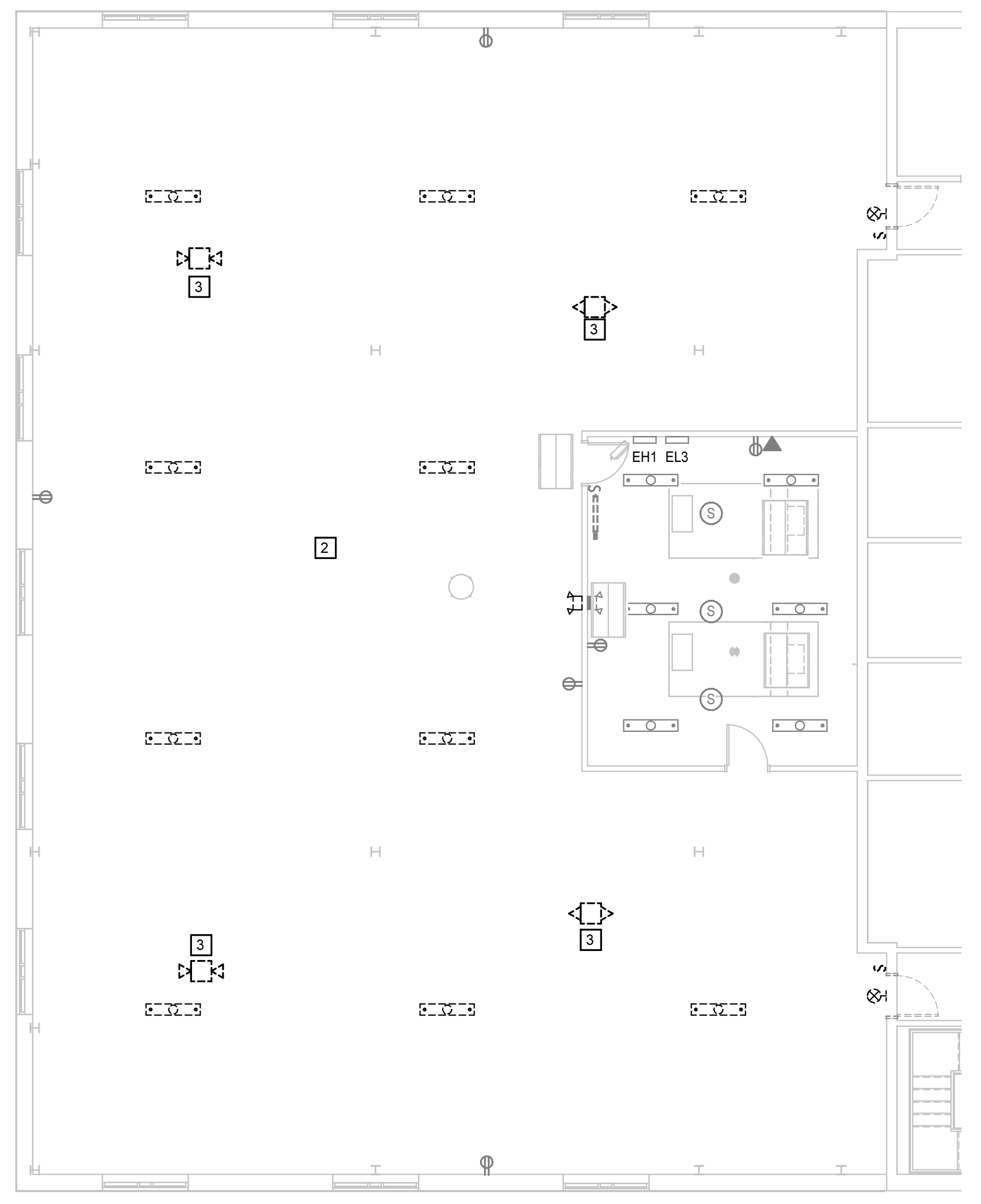

**SECOND FLOOR PLAN - DEMOLITION PLAN**  
 1/8" = 1'-0"

PROJECT NO:	631797
DATE:	FEBRUARY 7, 2024
REVISIONS:	
DATE:	DESCRIPTION:

LIGHT FIXTURE SCHEDULE											
TYPE	DESCRIPTION	MANUFACTURER	FIXTURE	SERIES NO.	VOLTAGE	WATTAGE	LUMENS	TYPE	LAMP	COLOR TEMP.	COMMENTS
A	2X2 RECESSED TROFFERS	LITHONIA	2BLT2	277 V	0	2671 lm	LED	4000 K	RECESSED	EMERGENCY BATTERY PACK WHERE INDICATED	
C	2X4 RECESSED TROFFER	LITHONIA	2BLT	277 V	47	6000 lm	LED	4000 K	RECESSED	EMERGENCY BATTERY PACK WHERE INDICATED	
D	8FT LINEAR RECTANGULAR PENDANT	NEO-RAY	S122DIP	277 V	82	9640 lm	LED	4000 K	PEDNANT	EMERGENCY BATTERY PACK WHERE INDICATED	675 LUMENS DOWN, 530 LUMENS UP, MOUNT 8" AFF
U	UNDER CABINET LIGHT	ACOLYTE	ACS	277 V	3	339 lm	LED	4000 K	SURFACE		
X1	EXIT SIGN	LITHONIA	LRP	277 V	5		LED			EMERGENCY BATTERY PACK WHERE INDICATED	

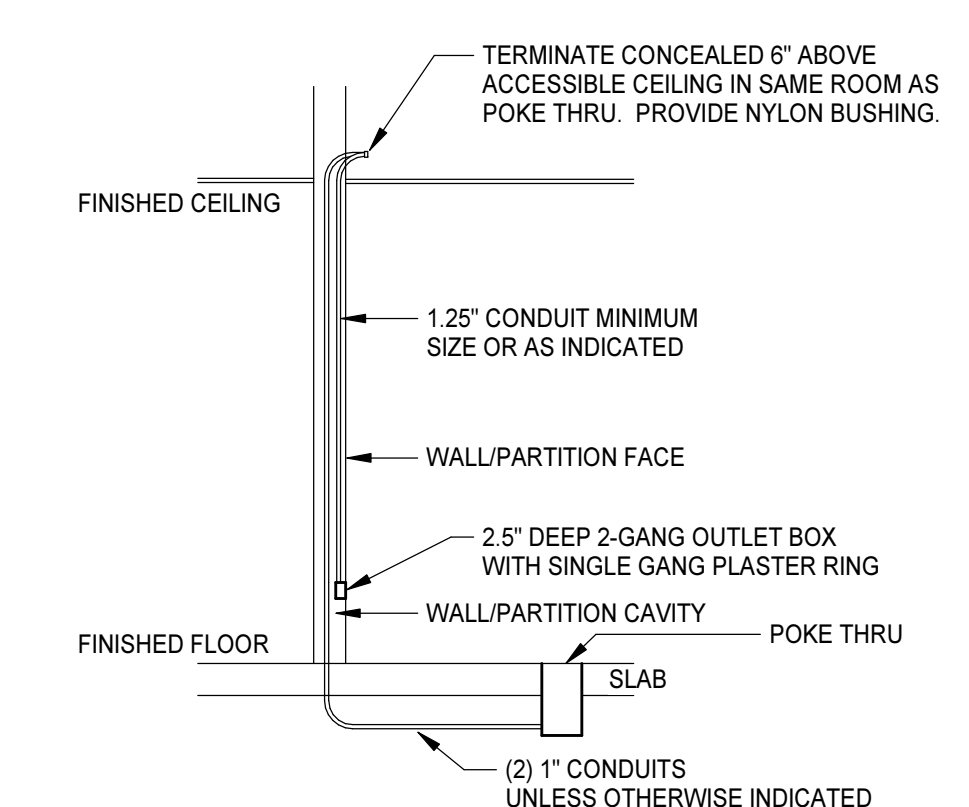
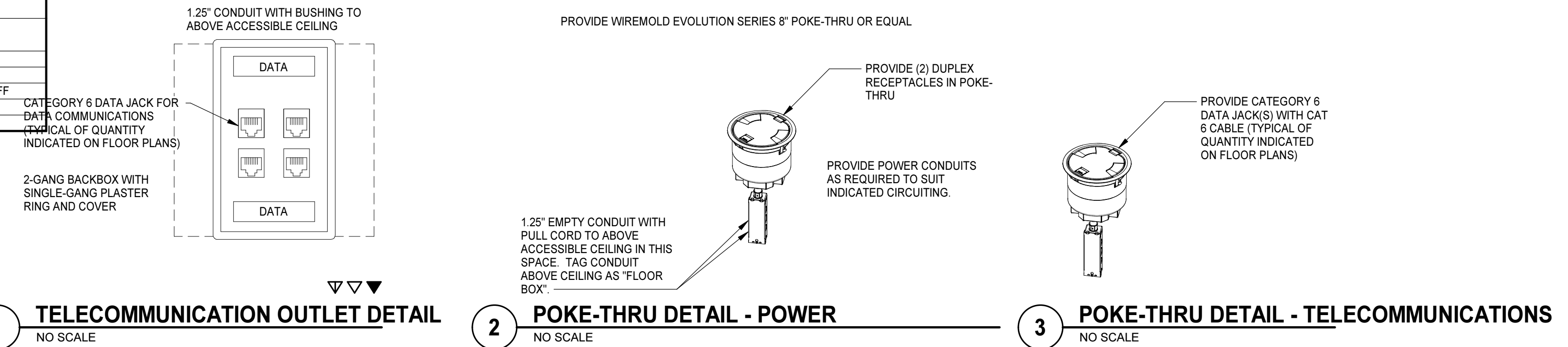

4 TELECOMMUNICATIONS OUTLET CONDUIT DETAIL - POKE THRU  
1/4" = 1'-0"

LOAD CALCULATION	
EXISTING PANEL MDP LOAD + 125%	343.8 KVA
ADDED LOAD	60.2 KVA
NET NEW LOAD	404 KVA
	486A

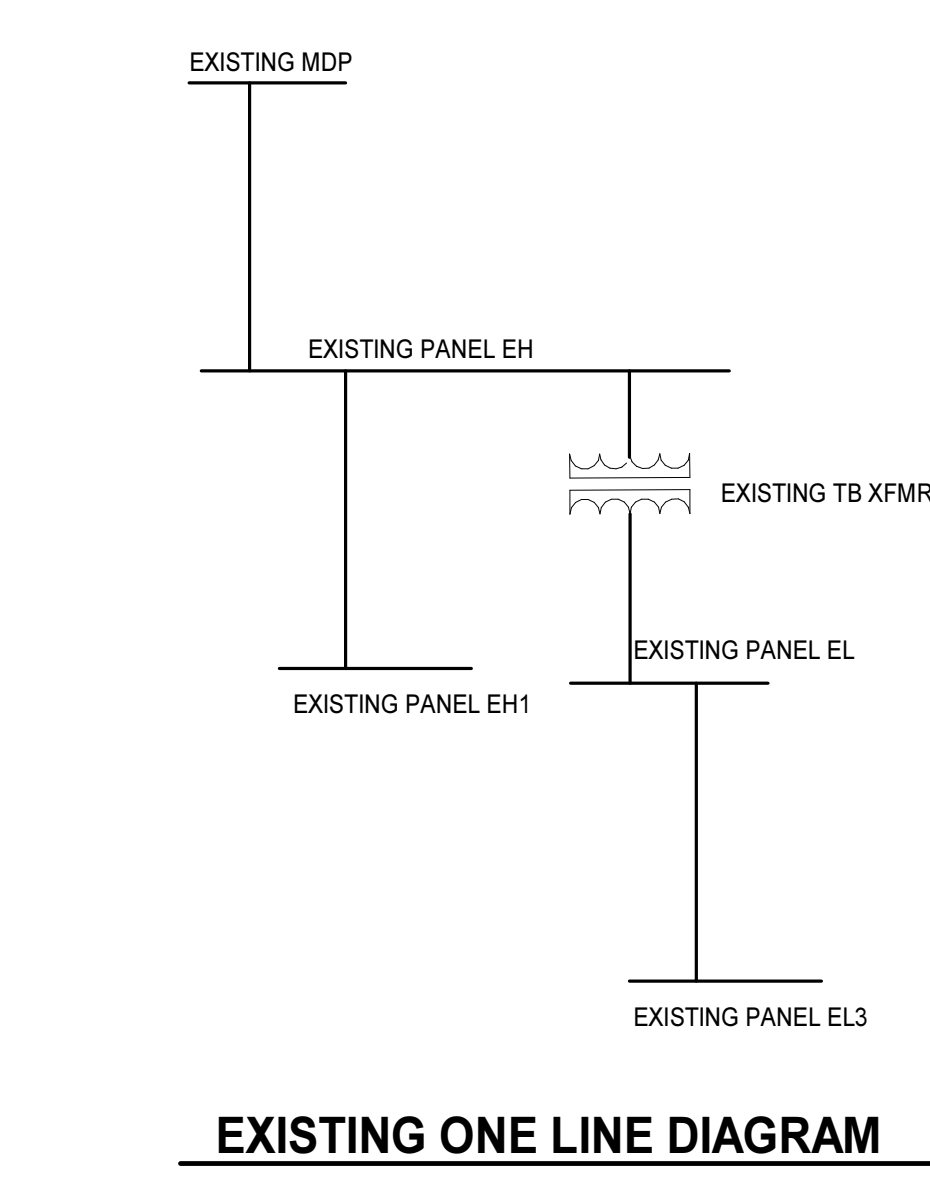

EXISTING PANELBOARD EL3										LOCATION: MECHANICAL 201	FED FROM:
100 AMP MCB	120/208 Wye			3 PH 4 W			MOUNT: SURFACE			PANEL ASSEMBLY RATED (KAIC): 10 KAIC	
CKT	BRKR	POLE	LOAD	A	B	C	LOAD	POLE	BRKR	CKT	
1	20 A	1	LUH-1	0.2	1.1		REC OFFICE 205 (EB)	1	20 A	2	
3	20 A	1	HVAC CONTROL PANEL		0.5	1.4	REC 203 204 202 213/212 (EB)	1	20 A	4	
5	20 A	1	HVAC CONTROL PANEL			0.5	1.1	REC 208 (EB)	1	20 A	
7	20 A	1	EF 29-01 (1110 HP)	0.1	1.1		REC 205 (EB)	1	20 A	8	
9	20 A	1	ROOFTOP REC		0.2	1.3	REC 206,207 (EB)	1	20 A	10	
11	--	1	SPACE ONLY			--	0.4	REC PRINTER 206 (EB)	1	20 A	
13	50 A	2	REC RANGE 213 (RB)	0.1	1.3		REC WORKSTATION 212 (EB)	1	20 A	14	
15	20 A	1	REC 213 (EB)		0.1	1.3	REC WORKSTATION 212 (EB)	1	20 A	16	
17	20 A	1	REC 213 (EB)			0.2	1.3	REC 207 (EB)	1	20 A	
19	20 A	3	SYSTEM FURNITURE 212 (RB)	0.2	1.3		REC 212 (EB)	1	20 A	20	
21	20 A	1	REC 213 (EB)		0.2	0.4	REC PRINTER 212 (EB)	1	20 A	22	
23	20 A	2	SYSTEM FURNITURE 212 (RB)			0.3	1.1	REC 215 (EB)	1	20 A	
25	20 A	1	REC 213 (EB)	0.3	1.3		REC 212,213 (EB)	1	20 A	24	
27	20 A	1	REC 202,216		1.4	0.3		SYSTEM FURNITURE 212 (RB)	2	20 A	
29	20 A	1	REC REFRIGERATOR 213 (GP)			0.2	0.3	REC 214 (EB)	1	20 A	
31	20 A	1	REC 213 (EB)	1.1	0.4			SOUND MASKING SYSTEM 202..	1	20 A	
33	20 A	1	REC 213 (EB)		0.4	1.1		REC 212 (EB)	1	20 A	
35	20 A	1	REC 211 (EB)			1.1	0.4	REC PRINTER 212 (PB)	1	20 A	
37	20 A	1	REC 210 (PB)	1.1	0.4			RECEPTACLES SPACE 20	1	20 A	
39	20 A	1	GARBAGE DISPOSAL		0.2	0.5		EXHAUST HOOD (PB)	1	20 A	
41	--	1	SPACE ONLY			--	--	SPACE ONLY	1	--	
				10 kVA	9 kVA	7 kVA					
				84 A	79 A	55 A					

EXISTING PANELBOARD EH1										LOCATION: MECHANICAL 201	FED FROM:
100 AMP MCB	480/277 Wye			3 PH 4 W			MOUNT: SURFACE			PANEL ASSEMBLY RATED (KAIC): 18 KAIC	
CKT	BRKR	POLE	LOAD	A	B	C	LOAD	POLE	BRKR	CKT	
1				2.1	0.6		PUMP P-1	3	15 A	2	
3	20 A	3	AHU-30		2.1	0.6				4	
5						2.1	0.6			6	
7				2.1	1.7					8	
9	20 A	3	AHU-29		2.1	0.0				10	
11						2.1	0.0			12	
13	20 A	1	TU-29-05,06,07,08	3.7	1.9					14	
15	20 A	1	TU-29-01,02,03-04			3.7	1.0			16	
17	20 A	1	SPARE			0.0	2.1			18	
19	20 A	1	SPARE	0.0	3.0					20	
21	20 A	1	SPARE		0.0	0.0				22	
23	20 A	1	SPARE			0.0	4.1			24	
25	20 A	1	SPARE	0.0	4.1					26	
27	20 A	1	SPARE		0.0	0.0				28	
29	20 A	1	SPARE			0.0	0.0			30	
31	20 A	1	SPARE	0.0	0.0					32	
33	20 A	1	SPARE			0.0	0.0			34	
35	20 A	1	SPARE			0.0	0.0			36	
37	20 A	1	SPARE	0.0	0.0					38	
39	20 A	1	SPARE		0.0	0.0				40	
41	20 A	1	SPARE			0.0	0.0			42	
				19 kVA	9 kVA	13 kVA					
				70 A	34 A	40 A					

**MOSELEY ARCHITECTS**  
 5200 NORFOLK STREET, RICHMOND, VA 23230  
 PHONE (804) 784-1857 FAX (804) 355-5690  
 MOSELEYARCHITECTS.COM

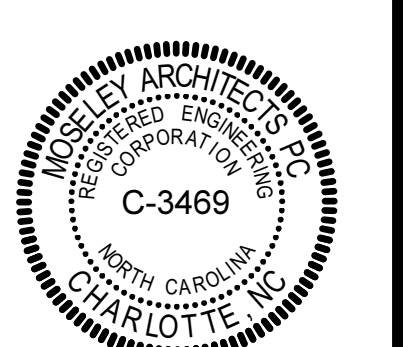
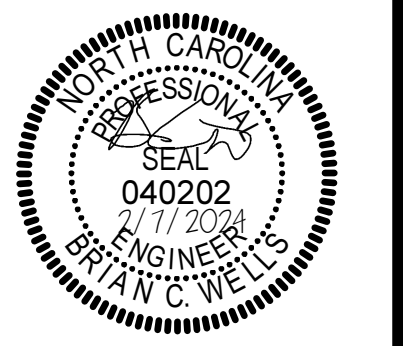

**HARNETT CO DSS UPFIT 2ND FLOOR**  
 631797  
 HARNETT CO DSS  
 311 W CORNELIUS HARNETT BLVD, LILLINGTON, NC 27546

PROJECT NO:	631797
DATE:	FEBRUARY 7, 2024
REVISIONS:	
DATE:	
DESCRIPTION:	

DIAGRAM, SCHEDULES & DETAILS

E5.1

2/8/2024 2:40:29 PM