



Reviewed for Fire Code Compliance  
Leslie Jackson  
10/20/2023 5:20:41 AM

# Application for Plan Review

Application # \_\_\_\_\_ - \_\_\_\_\_

Date Received: \_\_\_\_\_ Received By: \_\_\_\_\_

Name of Project: The Little Goat Soda Fountain and Candy

Physical Address of Project: 28 E Depot St

Angier, NC 27501

Plans Submitted By: Jennifer Sloan

Project Phone: ( 252 )-469 - 0450

Contact Person/Address: Jennifer Sloan

27 Wilma St

Angier, NC 27501

Contact Email: jsloan78@gmail.com

Contact Phone: ( 252 )-469 - 0450 (\_\_\_\_)-\_\_\_\_-\_\_\_\_

Contractor's Name/Info: Jennifer Sloan (heading up project); Brian Young, electrician

Dennis Mennella, plumber; Bob Jusnes, carpenter

Contractor's Phone: ( 252 )-469 - 0450

- Plans that are submitted will be reviewed as quickly as possible with an average time of review between 7-10 working days.
- Status checks may be conducted on plan reviews by visiting the website <http://htweb.harnett.org/Click2GovBP/Index.jsp> or by calling the Harnett County Central Permitting Office (910-893-7525, Option #2), or the Harnett County Fire Marshal's Office (910-893-7580).
- Approved plans must be picked up from the Central Permitting Office and all fees paid before any required inspections can be conducted.

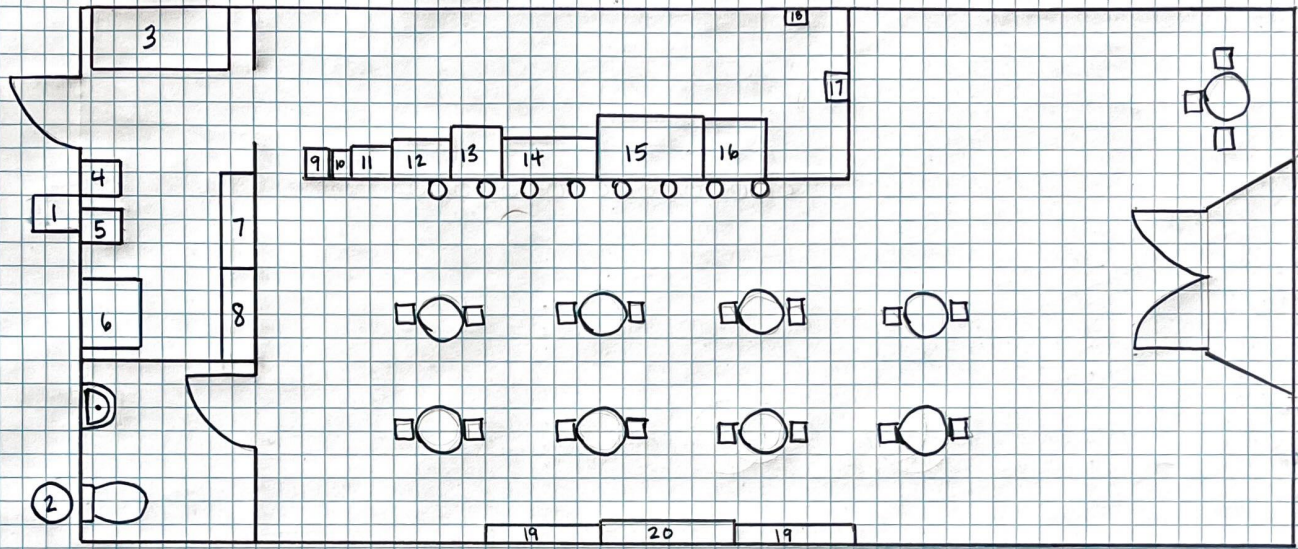

- 1. Utility Tub
- 2. Water Heater
- 3. Freezer
- 4. Ice Maker
- 5. Dishwasher
- 6. HVAC Ductwork
- 7.+8. Storage Racks

- 9. Hand sink
- 10. CO2
- 11. Carbonator
- 12. BIB rack
- 13. Ice bin
- 14. 3 compartment sink
- 15. ice cream dipping cabinet
- 16. refrigerator
- 17. P.O.S. system
- 18. Navor pump

- 19. display shelves
- 20. bench

- The Little Goat Soda Fountain + Candy
- 28 E Depot St, Angier
- Jennifer Sloan

1 sq = 1 foot



TOWN OF ANGIER  
COMMERCIAL PERMIT

55 NORTH BROAD ST WEST ANGIER, NC 27501-0278

Phone: 919-331-6702 FAX: 919-639-6130

DATE ISSUED: 09/08/2023

PERMIT #: 2023-000701

LOCATION	DISTRICT	TAX MAP PARCEL#
	CB	04067320100022
28 EAST DEPOT STREET	LOT	ZONING DISTRICT
		CB
OWNER: THE LITTLE GOAT SODA FOUNTAIN		TOTAL VALUATION
CONTRACTOR:		\$ 0

SUBCONTRACTOR ID/NAME

SUBCONTRACTOR TYPE

TYPE CONSTRUCTION: COMMERCIAL

OCCUPANCY GROUP: COMMERCIAL

<u>FEE CODE</u>	<u>FEE</u>
LAND USE RESIDENTIAL	50.00
TOTAL PAID: 50.00    **PAID IN FULL**	TOTAL AMOUNT: 50.00

REMARKS: ZONING COMPLIANCE/ NEW INCOMING BUSINESS PERMIT: RETAIL & RESTAURANT ; THE LITTLE GOAT SODA FOUNTAIN

\_\_\_\_\_  
(SIGNATURE OF CONTRACTOR/OWNER)

\_\_\_\_\_  
(DATE)

*Janet Spear*  
\_\_\_\_\_  
(ISSUED BY)

09/08/2023  
\_\_\_\_\_  
(DATE)

# Water Heater

2.



PRODUCTS

PRODUCT SELECTOR

SUPPORT

WHERE TO BUY



## RESOURCES

### Specifications

Nominal Capacity: ?	40	Type:	Short
Rated Storage Volume: ?	37	Height:	49 3/4"
UEF:	0.92	Diameter:	20 1/2"
Family Size:	3	Width:	20 1/2"
Self Cleaning:	Yes	Depth:	20 1/2"
Limited Warranty Tank:	6 years	Weight:	
Limited Warranty Parts:	6 years		
Max Wattage:	4500		
Voltage:	240		
Water Connection Location:	Top		
Water Connection Size:	3/4"		

Water Heater



LLC

ELECTRIC STORAGE  
TANK WATER HEATER



LISTED  
932N

MODEL NUMBER		SERIAL NUMBER			ITEM ID / PART NUMBER	
E6-40R45DV 110		2326134724811			100341521	
VOLTS - AC	PHASE	WATTS UPPER	WATTS LOWER	TOTAL WATTS CONNECTED	NOMINAL CAPACITY US GAL.	MAX WORKING PRESSURE
240	1	4500	4500	4500	40	150
VOLTS AC	ALTERNATE RATINGS WATTS UPPER	WATTS LOWER	TOTAL WATTS CONNECTED		CIRCUIT	
208	3380	3380	3380		A6	

A. O. SMITH CORPORATION  
HIGHWAY 1  
MCBEE, SC



Model Number E6-40R45DV 110

1700



Serial Number 2326134724811

# Chest Freezer

3

Frigidaire  
19.8 Cu. Ft. Chest Freezer

Overview Features Accessories Specs Reviews For Owners

\$948.00

Add to cart

## Controls

- Control Location
- Digital Display
- Door Ajar Alarm
- High Temp Alarm
- Power Failure Alarm

Side of Door

- Yes ADA Compliant
- No ENERGY STAR Certified
- Yes CSA Listed
- No ETL Listed
- NSF Certified

## Electrical Specifications

Minimum Circuit Required

15 Amps

- Casters
- Lid Finish
- Lock

## General Specifications

- Annual Energy 361 kWh
- Leveling Legs Yes
- Product Weight 181 lbs
- Prop 65 Label Yes
- Refrigerant Type R-600A
- Warranty - Labor 1 Year
- Warranty - Parts 1 Year

## Performance Certifications and Approvals

## Exterior

## Dimensions and Volume

- Height With Lid 31 3/4"
- No Height Without Hinge 31 3/4"
- No Width 73 11/16"
- Yes Depth of Cabinet 29 9/16"
- No Freezer Capacity 19.8 Cu. Ft.
- No

## Freezer

- Yes Baskets / Bins Material Plastic
- Smooth Interior Lighting LED
- Yes Manual Defrost Yes
- Pizza Bin No
- Number of Baskets / Bins 2



CHAT



Challenge A  
Accompl...nts-fave

**Scotsman**  
UNDERCOUNTER UNITS

# UN1520 - 150 lb Nugget Ice Machine

Self-Contained Undercounter Ice Machine with Storage

## Features and Benefits

### Space Saving Design:

- Only 20" wide, this ice maker can be placed in the tightest locations
- Front breathing - No side clearance required for flexible placement
- Optional floor mount kit allows for installation under 34" ADA counter tops

### Ease of Use:

- Unit specific QR code for quick access to service manuals, cleaning guides and warranty history
- Ergonomic slide back door allows easy access to ice in the bin
- Power cord, NEMA 5-15P plug, ice scoop and adjustable legs are included for quick and easy installation

### Reliability:

- Sealed, maintenance-free bearings for reduced preventative maintenance and long-lasting performance
- Stainless steel evaporator and auger for maximum durability
- Heavy duty, rust-free front panel and corrosion-resistant aluminum alloy side panels for maximum lifespan
- 3 Year parts and labor warranty
- Designed, engineered and assembled in the USA

### High Production:

- Produces up to 167 lb (76 kg) per day and stores 57 lb (26 kg), maximizing ice output despite its small footprint
- Maximized production ensures that you can keep up with growing demand for The Original Chewable® Nugget Ice

### Environmentally Friendly:

- Energy Star certified
- Meets US Safe Drinking Act low lead requirements
- Non-ozone depleting R-134A refrigerant

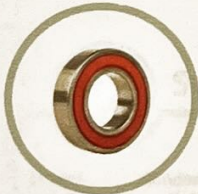

Sealed, maintenance-free bearings ensure maximum reliability and contribute to a long machine life



Unit specific QR code for quick access to service manuals, cleaning guides and warranty history



Ergonomic slide back door allows easy access to ice in the bin



ADA compliant with optional floor mount kit



## 24 Hour Volume Production

Air Cooled		
70°F/21°C	Air	90°F/32°C
50°F/10°C	Water	70°F/21°C
167/76		125/57
lb/kg		lb/kg



## Nugget Ice



The Original Chewable Ice®! Soft ice ideal for fountain beverages and blended fruit drinks.



## Certification



## Warranty

- 3 years parts and labor on all components
- Warranty valid in North, South & Central America for commercial installations
- Contact factory for warranty in other regions
- Residential Applications: 1 year parts and labor

UN1520 - 150 lb Self-Contained Ice Machine

**Scotsman**  
UNDERCOUNTER UNITS

# UN1520 - 150 lb Nugget Ice Machine

Self-Contained Undercounter Ice Machine with Storage

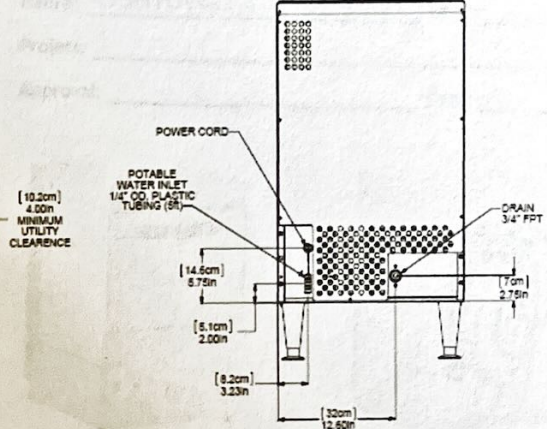
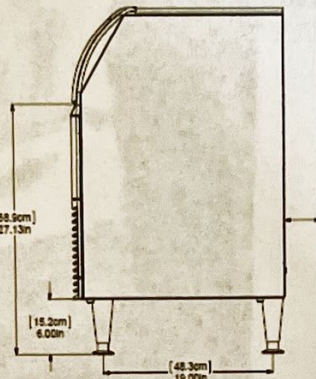
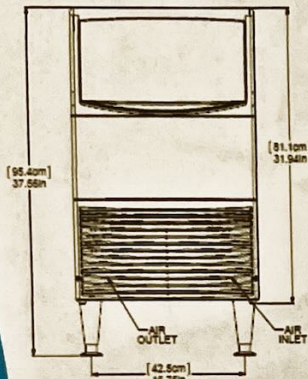
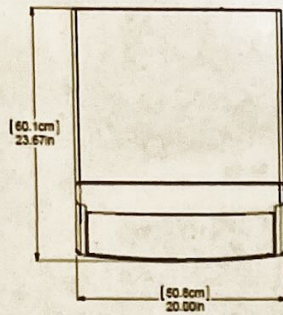

Front and no side clearance required, allowing for flexible placement

UN1520 - 150 lb Self-Contained Ice Machine



## Specifications

Model Number	Condenser Unit	Storage Capacity lb/kg	Basic Electrical Volts/Hz/Phase	Max. Fuse Size or HACR Circuit Breaker (amps)	Circuit Wires	Min. Circuit Ampacity	Energy Consumption kWh/100 lb (45.4 kg) 90°F(32°C)/70°F(21°C)	Potable Water Usage Gallons/100 lb (liters/45.4 kg) 90°F(32°C)/70°F(21°C)
UN1520A-1	Air	57/26	115/60/1	15	2	Cord	5.23	12/45.5



## All Models

### Dimensions (W x D x H):

Unit: 20" X 24" X 38"  
(50.8 x 61.0 x 96.5 cm)

Includes 6" (15.24 cm) adjustable legs

Shipping Carton: 22" x 27" x 38"  
(55.9 x 68.6 x 96.5 cm)

Shipping Weight: 129 lb / 59 kg

BTUs per hour: 4,100

Refrigerant: R-134A



## Accessories

Model Number	Description
KLP8S	Kit, Leg 6", Stainless Steel
KBC1	Kit, Casters
KUFM20	For ADA applications. Floor mount kit lowers overall height to 31.9"

Scotsman recommends all ice machines have water filtration. See Scotsman water filter specification sheet for details.



## Operating Requirements

	Minimum	Maximum
Air Temperatures	50°F (10°C)	100°F (38°C)
Water Temperatures	40°F (4.4°C)	100°F (38°C)
Water Pressures	20 PSIG (1.4 bar)	80 PSIG (5.5 bar)
Electrical Voltage	-5%	+10%

Specifications and design are subject to change without notice.



5.



## Noble Warewashing HTGW High-Temperature Underbar Glass Washer - 208V/240V, 1 Phase

#495HTGW22



Item #: 495HTGW22 Qty: \_\_\_\_\_

Project: \_\_\_\_\_

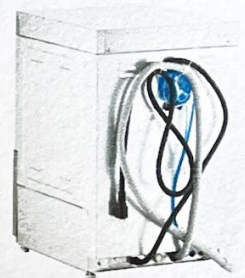

Approval: \_\_\_\_\_ Date: \_\_\_\_\_



### Features

- 304 stainless steel construction is durable and made to last
- Cleans up to 22 racks; 792 glasses per hour
- Electromechanical controls are convenient and easy to access
- Efficient heat element and 1/3 hp wash pump motor maintains final rinse temperatures
- Ideal for commercial kitchens, hotels, and restaurants

### Certifications

 ETL Sanitation
  ETL US & Canada
  3/4" Water Connection

 6-20P

### Technical Data

Width	18 1/2 Inches
Depth	20 5/8 Inches
Height	28 1/8 Inches
Interior Width	18 1/2 Inches
Interior Depth	16 1/2 Inches
Interior Height	11 3/4 Inches
Amps	13.3 Amps
Hertz	60 Hertz
Phase	1 Phase
Voltage	208/240 Volts

5. glass washer

Technical Data	
Booster Tank Capacity	1.1 gal.
Features	Booster Heater Included Built-In Detergent and Rinse Aid Dispenser Built-In Drain Pump
Glasses Per Hour	792
High or Low Temp	High Temp
Horsepower	1/3 HP
Interior Clearance	10 5/8 Inches
Minimum Water Inlet Temperature	120 Degrees F (140 Recommended)
Number of Wash Cycles	1 Wash Cycle
Plug Type	NEMA 6-20P
Racks Per Hour	22
Style	Rack
Type	Glass Washers
Wash Cycle Time	120 Seconds
Wash Tank Capacity	4 gal.
Water Inlet Size	3/4 Inches
Water Temperature	140 - 180 Degrees F
Water Usage	0.53 Gallons per Cycle

## Notes & Details

Choose a reliable product with this Noble Warewashing HTGW high-temperature underbar glass washer - 208V/240V, 1 phase. This glass washer is constructed with durable 304 stainless steel that is sleek and made to last. It is also extremely efficient. It uses only .53 gallons of water per cycle and can clean an impressive 22 racks; 792 glasses per hour. This high-temperature glass washer has an operating water temperature of 140 degrees Fahrenheit and a rinsing water temperature of 180 degrees Fahrenheit. This unit is perfect for commercial kitchens, hotels, and restaurant settings.

This glass washer sports a powerful 1/3 hp wash pump motor. Its heating element is extremely effective and maintains final rinse temperatures for each cycle. Its electromechanical controls are intuitive and easy to use. It operates using a 120 second cycle that is great for high-volume usage. To help keep your operation organized, this glass washer includes two flat 16" x 16" racks, a cutlery container, and a dish rack. It also includes a built-in detergent and rinse aid dispenser, and a booster heater. The booster heater tank has a 1.1 gallon capacity that is ideal for high-volume use. This unit also features a waste accumulator that is easy to clean and keeps the operation running effectively.

**⚠ WARNING:** This product can expose you to chemicals including lead, which are known to the State of California to cause cancer, birth defects, or other reproductive harm. For more information, go to [www.p65warnings.ca.gov](http://www.p65warnings.ca.gov).

7,8

**REGENCY**  
Space Solutions

**Regency 24" x 48" NSF Green Epoxy 4-Shelf Kit with 74" Posts**

#460EG2448KIT

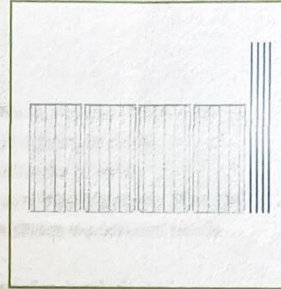
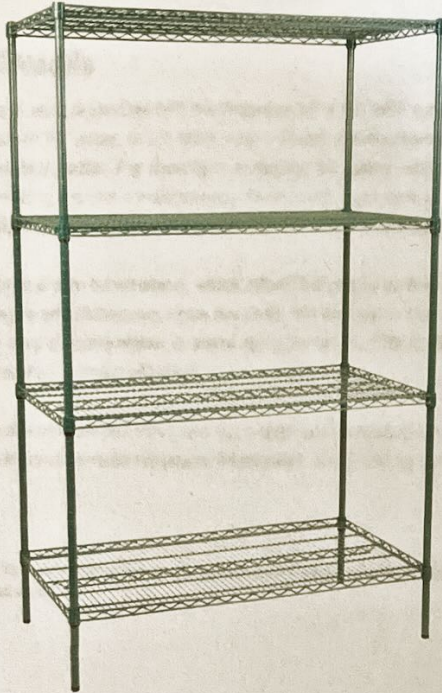

**Technical Data**

Length	48 Inches
Width	24 Inches
Height	74 Inches
Assembled	Assembly Required
Capacity	2400 lb.
Casters	Without Casters
Color	Green
Features	NSF Listed
Finish	Green Epoxy
Individual Shelf Capacity	600 lb.

**Features**

- Epoxy coating is corrosion resistant and suitable for moist/humid environments
- (4) 24" x 48" shelves accommodate up to 600 lb. each
- (4) 74" stationary posts allow for shelves to be adjusted; foot included and required for use
- Includes 16 pairs of split sleeves
- Wire design promotes proper air flow around stored products

**Certifications**



7,8

## Technical Data

Material	Epoxy-Coated Steel
Number of Shelves	4 Shelves
Style	Adjustable Stationary Vented
Type	Shelving Kits
Usage	All Environments Dry Environments Moist Environments

## Notes & Details

Keep your storage area organized with the Regency 24" x 48" NSF green epoxy shelf kit! This kit includes (4) 24" x 48" wire shelves and (4) 74" posts, which allow you to create a convenient storage solution for your janitorial closet, warehouse, or walk-in cooler. For maximum versatility, the epoxy coating allows for use in either dry or moist environments, making the unit a multipurpose investment that's sure to accommodate your ever-evolving needs. Plus, the unit's high-quality design is commercial grade and delivers the reliable performance every business expects and needs.

Each shelf features a wire construction, which allows for proper air flow around the stored supplies, products, or ingredients. They're adjustable, too; since the posts are marked in intervals and use a split sleeve system of assembly, the shelves are easy to move higher or lower along the posts. This is especially great for expanding businesses that may not have finalized their product offerings.

16 pairs of split sleeves are provided, and each shelf accommodates up to 600 lb. of weight. Likewise, a foot is provided for each post and must be used for proper installation. The shelving unit requires assembly.

**⚠ WARNING:** This product can expose you to chemicals including lead, which are known to the State of California to cause cancer, birth defects, or other reproductive harm. For more information, go to [www.p65warnings.ca.gov](http://www.p65warnings.ca.gov).

### Features

- 4 green epoxy-coated shelves included
- 4 heavy-duty 74" stainless steel posts
- 16 pairs of 24" x 48" NSF green epoxy shelves included
- 16 pairs of split sleeves included

### Applications



**REGENCY™**  
Tables and Sinks

**Regency 12" x 16" Wall Mounted Hand Sink with  
Gooseneck Faucet**

#600HS12

9.

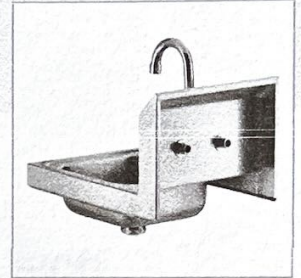

**Technical Data**

Length	12 Inches
Width	16 Inches
Height	10 Inches
Bowl Depth	4 Inches
Bowl Front to Back	9 Inches
Bowl Left to Right	9 Inches
Compliances	Commonwealth of Massachusetts
Faucet Centers	4 Inches
Features	Faucet Included NSF Listed

**Features**

- 8" gooseneck faucet included
- Perfect for hand washing throughout the workday
- 20-gauge type 304 stainless steel
- Single 9" x 9" x 4" bowl includes 1 1/2" IPS drain basket
- Holes punched on 4" centers; 8" backsplash

**Certifications**



9.

## Technical Data

Flow Rate	2 GPM
Gauge	20 Gauge
Installation Type	Wall Mounted
Material	Stainless Steel
Number of Compartments	1 Compartment
Number of Faucets	1
Stainless Steel Type	Type 304
Type	Hand Sinks

## Plan View

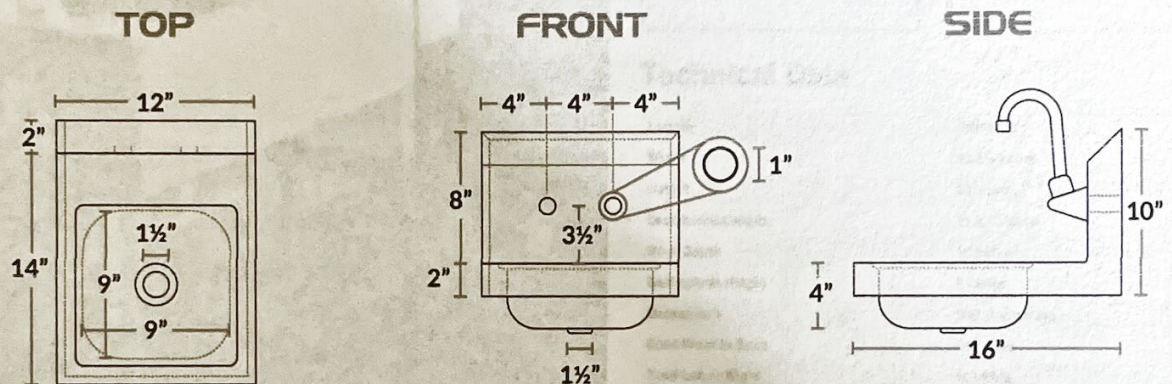

## Features

## Notes & Details

Keep your restaurant up to code without sacrificing space with this Regency HS-12 space saving hand sink. Each sink comes standard with a single 9" x 9" x 4" bowl and a convenient 8" high back splash. Additionally, this hand sink has two holes punched on 4" centers to accept the included Regency 8" gooseneck faucet.

This sink offers an economical, 20-gauge type 304 stainless steel construction along its top, bowl, and backsplash. It comes standard with a 1 1/2" IPS drain basket.

**WARNING:** This product can expose you to chemicals including Nickel and Lead, which are known to the State of California to cause cancer, birth defects, or other reproductive harm. For more information, go to [www.p65warnings.ca.gov](http://www.p65warnings.ca.gov).

14.

**REGENCY**  
Tables and Sinks

**Regency 3 Bowl Underbar Sink with Drainboard - 48" x 18 3/4" - Left Drainboard**

#600B3101413L

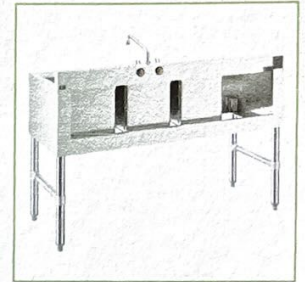
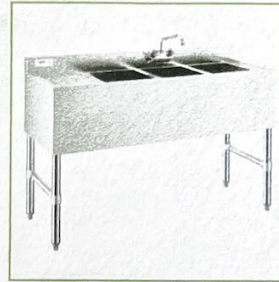

**Technical Data**

Length	48 Inches
Width	18 3/4 Inches
Height	33 Inches
Drainboard Length	11 3/4 Inches
Bowl Depth	10 Inches
Backsplash Height	3 Inches
Backsplash	With Backsplash
Bowl Front to Back	14 Inches
Bowl Left to Right	10 Inches
Compliances	Commonwealth of Massachusetts

**Features**

- Durable stainless steel construction
- Three 2" drains (1 1/2" IPS) with drain baskets included
- Galvanized legs with bullet feet
- Deep bowls accommodate tall glasses and pitchers
- Drainboard aids in fast drying

**Certifications**



## Technical Data

Features	NSF Listed
Gauge	18 Gauge
Leg Construction	Galvanized Steel
Material	Stainless Steel
Number of Bowls	3 Bowls
Number of Compartments	3 Compartments
Number of Drainboards	1 Drainboard
Stainless Steel Type	Type 304
Type	Bar Sinks

## Plan View

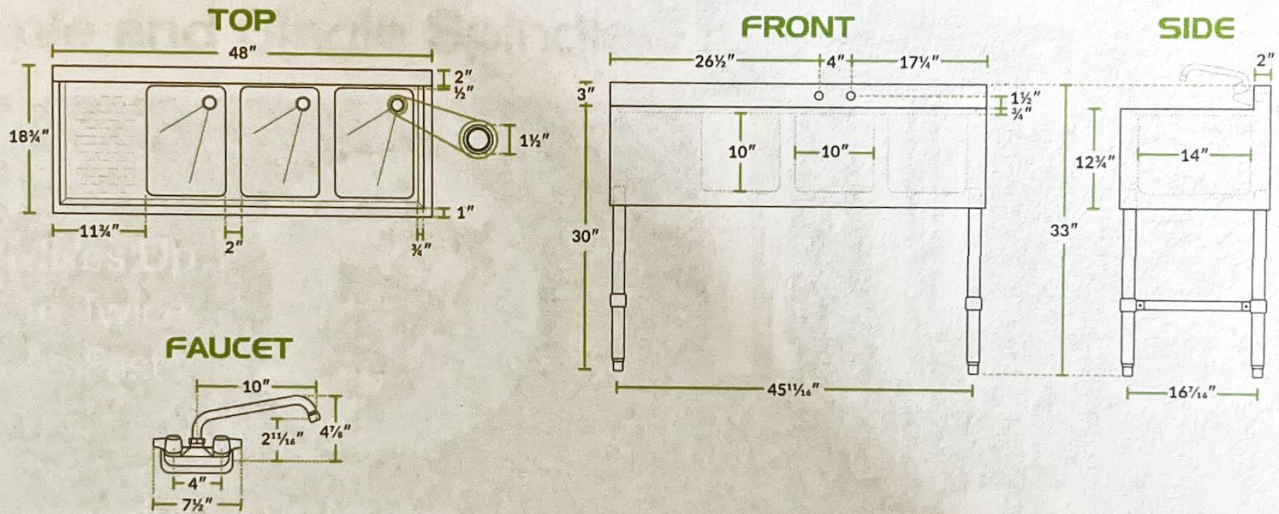

## Notes & Details

This 3-bowl bar sink is designed for a standard wash, rinse, and sanitize operation. It comes with your choice of a left- or right-side 11 3/4" drainboard for efficient washing and drying of your barware. The deep, 10" sink bowls accommodate all types of glasses, including pitchers! As an added convenience, it features a 3" high backsplash to keep your bar better protected from accidental spills. This 3-bowl underbar sink has two holes punched on 4" centers.

This sink offers a durable 18-gauge type 304 stainless steel construction along its top, bowls, and back. For maximum stability, it has 16-gauge galvanized steel legs with plastic bullet feet.

**WARNING:** This product can expose you to chemicals including lead, which are known to the State of California to cause cancer, birth defects, or other reproductive harm. For more information, go to [www.cd5warnings.ca.gov](http://www.cd5warnings.ca.gov).



15

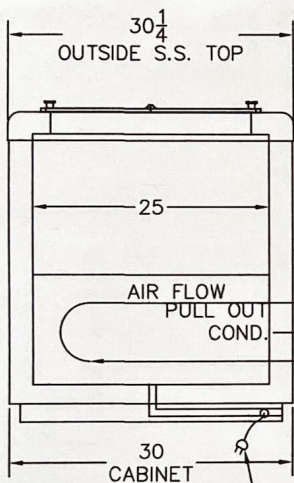

DIGITAL  
THERMOSTAT

CUT DOWN TO  
1/2" FOR VENTING

SERVICE CORD  
EXTENDS 7'  
FROM BASE

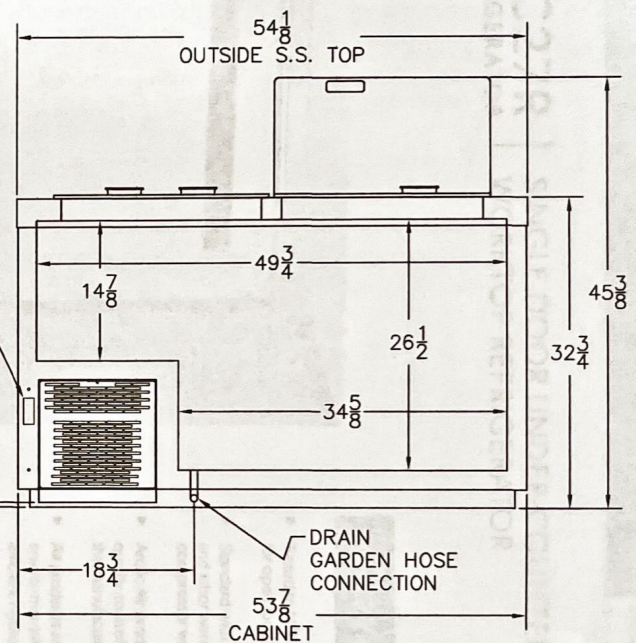

HP	Volts	Amps	Wt. lbs
1/3	115/220	8/4	325

REV.	C. NELSON MFG.		
TITLE:	BD8		
USED ON:	FINISHED GOODS	1 OF 1	
DWN. BY:	RMP	PART NO.:	BD8
DATE:	06/05/98		
SCALE:	AUTO		
REV.	NR		



Stainless design.  
Stellar performance.  
Superior value.

Project name: \_\_\_\_\_

Location: \_\_\_\_\_

Item #: \_\_\_\_\_ QTY: \_\_\_\_\_

Model #: \_\_\_\_\_

# AUC27R

REFRIGERATOR

# SINGLE DOOR UNDER-COUNTER WORKTOP REFRIGERATOR



## AUC27R

- ▶ Tested to NSF Standard 7 requirements for open food storage.
- ▶ Standard with full two year parts and labor warranty and a five year compressor warranty.
- ▶ Arctic Air products must pass numerous quality control inspections throughout the manufacturing process.
- ▶ All products are pressurized with environmentally friendly and more efficient Hydrocarbon gas.
- ▶ Energy Star approved.



COMMERCIAL FREEZERS & REFRIGERATORS

Division of Broich Enterprises, Inc. 7550 Market Place Dr Eden Prairie, MN 55344  
952-941-2270 Fax: 952-941-3066 www.arcticalco.com info@arcticalco.com



16

# AUC27R

REFRIGERATOR

## SINGLE DOOR UNDER-COUNTER WORKTOP REFRIGERATOR

All units come standard with heavy-duty worktop surface.

Exterior cabinet construction consists of full stainless steel front and sides.

One adjustable, heavy-duty epoxy coated wire shelves.

Interior cabinet walls are constructed of white epoxy coated steel liner with full hi-level stainless steel covered corner floor.

Efficient condensate hot gas loop built into condensate pan for energy saving evaporation of excess condensate water.

Electronic thermostat with external digital LED display for accurate control and easy reading.

Easy to mount casters (two lockable) are standard with all units.

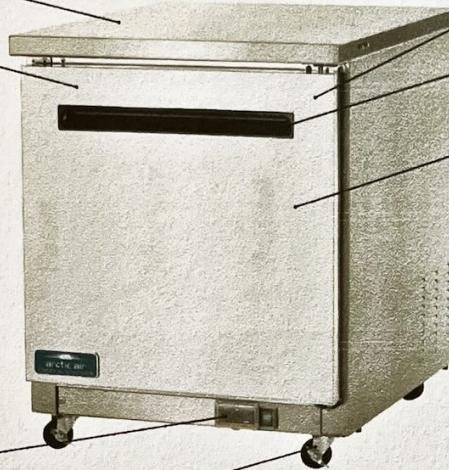

Vaulted self closing doors that remain open at 90 degrees.

Solid door construction with foamed-in-place recessed handle.

Magnetic door gaskets are removable and replaceable without tools.

Larger fan motors and blades for more efficient air flow ensuring faster recovery times.

Self-contained capillary tube system using environmentally friendly R600a Hydrocarbon gas.

- ▶ Tested to NSF Standard 7 requirements for open food storage.
- ▶ Standard with full two year parts and labor warranties and a five year compressor warranty.

### STAINLESS STEEL DESIGN • STELLAR PERFORMANCE • SUPERIOR VALUE

Model Number	External Dimensions			Doors	Epoxy Coated Shelves (horizontal)	Cubic Feet	Temperature Range	Cord Length	HP	AMPS	REF	NEMA Plug	Crate Weight
	Width	Depth	Height*										
AUC27R	27.875"	30"	35.625"	1	1	5.4	33°F to 41°F	8'	3/8	1.5	R600a	5-15P	185Lbs

Depth with door open 90° = 56.50"  
 \*Height includes 3" for casters  
 Height with worktop removed = 34.125"

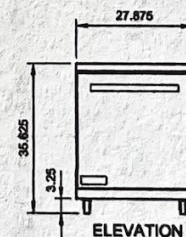
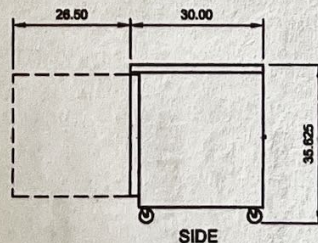
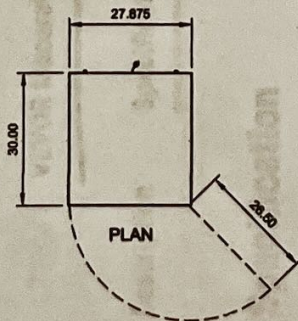



## VEVOR Macerator Pump, 350W, 6000 L/h Flow, 23 ft/7 m Head, Macerator Sewerage Sump Pump with 3 Water Inlets for B...

Description

**Specification**

Questions and Answers

Reviews

### Specification

Item Model Number	FLO300	Power	350W
Voltage	115V/60Hz	Max Flow Rate	6000 L/h
Max Head Lift	23 ft/7 m	Material	PP-GF20
Motor Speed	3600 RPM	Water Inlet Diameter	1.6"/40 mm
Water Outlet Diameter	1.1"/28 mm	Insulation Class	B
Waterproof Rating	IPX8	Product Weight	11.5 lbs/5.2 kg
Product Size (L x W x H)	11.8" x 6.5" x 7.1"/300 x 165 x 180 mm	Manual	<a href="#">↓ Download Link</a>