

- SYSTEM REQUIRES A MINIMUM OF 7 FT OF EQUIVALENT PIPE LENGTH BETWEEN TANK AND NEAREST APPLIANCE NOZZLE FOR MOST APPLIANCES. EACH 90 DEGREE ELBOW ADDS 1.3 FT OF EQUIVALENT LENGTH. SEE MANUAL FOR DETAILS

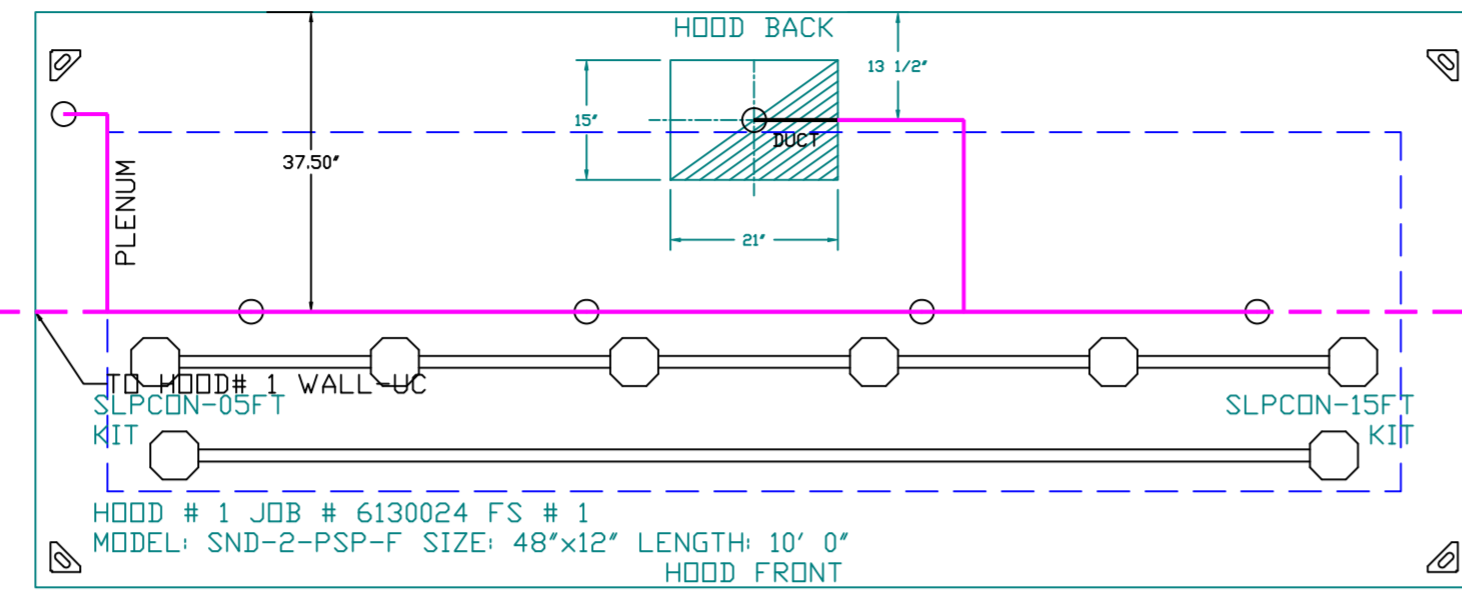

ALTERNATE FIELD-CONNECTION POINT

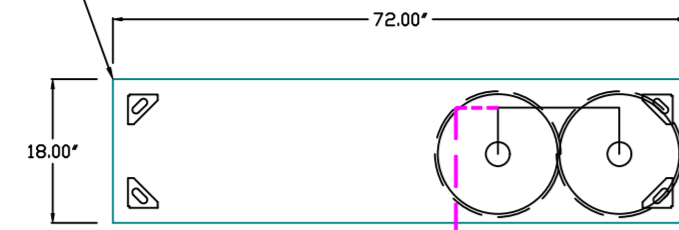
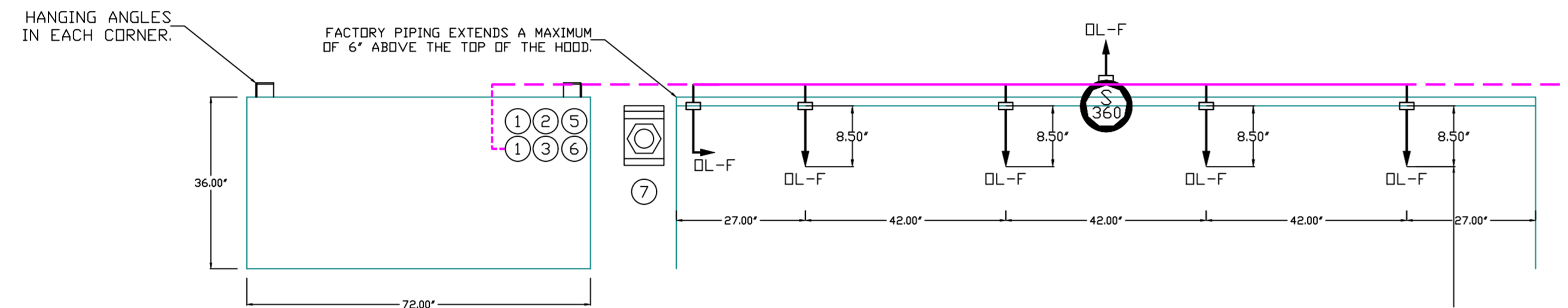

HANGING ANGLES IN EACH CORNER.

FACTORY PIPING EXTENDS A MAXIMUM OF 6' ABOVE THE TOP OF THE HOOD.

NOZZLE HEIGHT 35'-50" FROM COOKING SURFACE. 65'-80"

TANK OVERLAPPING PROTECTION - 30 HIGH PROXIMITY 108.00' L X 30.00' D

- FLAT TOP GRIDDLE HIGH PROXIMITY 36.00' L X 30.00' D
- FOUR BURNER RANGE HIGH PROXIMITY 24.00' L X 30.00' D
- TWO FRYERS HIGH PROXIMITY 30.00' L X 30.00' D

- NOTES
- FIELD PIPE DROPS AS SHOWN
  - PIPING, ELBOWS, TEES, AND NOZZLES SUPPLIED BY CAS.
  - FIELD INSTALLED DROP: FACTORY WILL PROVIDE QTY 2 60IN LONG PIECES OF CHROME PLATED PIPING SHIPPED LOOSE TO BE FIELD-INSTALLED.
  - SHIP LOOSE DROP: FACTORY WILL PROVIDE THE EXACT CHROME PIPE LENGTH NEEDED SHIPPED LOOSE TO BE FIELD-INSTALLED.
  - RELOCATE NOZZLES IF FLOW PATTERN IS BLOCKED BY SHELVING, SALAMANDERS, ETC.
  - OVERLAPPING COVERAGE SHALL NOT BE USED ON ANY APPLIANCE WITH AN OBSTRUCTION.
  - IF APPLICABLE, EXTENDED PRE-PIPED DROPS ARE SHIPPED LOOSE.
  - FACTORY PIPING EXTENDS A MAXIMUM OF 6' ABOVE THE TOP OF THE HOOD.

- APPLIANCE DIMENSIONS LISTED REPRESENT THE COOKING SURFACE SIZE, NOT THE OVERALL APPLIANCE SIZE.
- THIS FIRE SYSTEM COMPLIES WITH UL 300 REQUIREMENTS.

DL-F NOZZLE PART NUMBER REPLACES 3070-3/8H-10-SS

JOB #: 6130024  
JOB NAME: CORNER GRILL - ANGIER.

SYSTEM SIZE: TANK-SP-2-WC TOTAL FP REQUIRED: 28.  
HOOD # 1 10' 0.00' LONG x 48' WIDE x 12' HIGH.  
RISER # 1 SIZE: 10" x 14".  
HOOD # 1 METAL BLOW-OFF CAPS INCLUDED.

- HEAVY-DUTY APPLIANCES (RATED 600°F) WILL REQUIRE AN ADDITIONAL DOWNSTREAM FIRESTAT IN THE EVENT THAT THE DUCTWORK CONTAINS ANY HORIZONTAL RUNS OVER 25 FT IN LENGTH.
- MEDIUM TO LIGHT-DUTY APPLIANCES (RATED 450°F) WILL NOT REQUIRE ANY ADDITIONAL DOWNSTREAM DETECTION.

LEGEND - FIRE CABINET TANK SYSTEM

- 4 GALLON TANK.
- PRIMARY ACTUATOR RELEASE.
- SECONDARY ACTUATOR RELEASE.
- PRESSURE SUPERVISION SWITCH.
- PRIMARY HOSE ASSEMBLY.
- SECONDARY HOSE ASSEMBLY.
- REMOTE MANUAL ACTUATION DEVICE.

INCLUDES: FIELD INSTALLATION AND HOOKUP DURING NORMAL BUSINESS HOURS BY CERTIFIED INSTALLERS ONLY IN THE LOCATION NOTED ABOVE. TWO SITE VISITS ONLY (ONE VISIT TO SET PULL STATION & SYSTEM HOOKUP AND ONE VISIT FOR ONE TEST). ADDITIONAL VISITS WILL RESULT IN ADDITIONAL CHARGES. ONE MECHANICAL OR ELECTRICAL GAS VALVE PER SYSTEM AT A MAXIMUM SIZE OF 2". PERMIT AND SYSTEM TEST. EXCLUDES: UNION LABOR & PREVAILING WAGE LABOR & WAGES WILL BE ADDED IF APPLICABLE. GAS VALVE INSTALLATION, ELECTRICAL HOOKUP AND CONNECTIONS, HANGING OF FIRE CABINET, SHUNT TRIP, HANDHELD EXTINGUISHERS, ON-SITE RE-PIPING DUE TO EQUIPMENT LAYOUT CHANGES.

REVISIONS	
DESCRIPTION	DATE

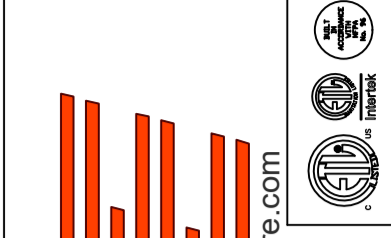

www.captiveaire.com



Eastern North Carolina

4641 Paragon Park Rd., Raleigh, NC, 27616 PHONE: (919) 825-3566 FAX: 9192275917 EMAIL: reg36@captiveaire.com

UL 300 HOOD FIRE SUPPRESSION SYSTEM  
TANK/CAS ELECTRIC WET CHEMICAL

The TANK / CAS-EWC Fire Suppression System has been tested and certified to the UL 1254 Standard for Pre-Engineered Chemical Extinguishing System Units and UL/ULC 300 Standard for Fire Extinguishing Systems For Protection of Commercial Cooking Equipment and is listed with Underwriters Laboratories (UL) under file number EX3553.

SEQUENCE OF OPERATIONS  
The TANK / CAS-EWC fire system is a self-contained pressurized fire suppression system. TANK / CAS-EWC is activated when the electric firestat contacts close (at determined firestat setting and/or temperature rate-of-rise of 40°F per minute) and/or the manual activation station is pushed, an electric signal is sent to the release solenoid of the fire system. When the release solenoid is opened, it allows stored pressure from the primary tank to travel through the primary actuator kit opening a pneumatic actuator. The pneumatic actuator forces the plunger in the tank valve body to open, allowing the liquid fire suppressant to be distributed throughout the fire system piping network over the protected hazard area.

CAPTIVE-AIRE HOODS ARE BUILT IN COMPLIANCE WITH:

CAPTIVE-AIRE HOODS ARE BUILT IN COMPLIANCE WITH

NFPA #96  
NSF  
UL 710 & ULC710 STANDARDS  
E.T.L. LISTED 3054804-001

\*FOR QUESTIONS\*  
CONTACT REGION 36  
EASTERN NORTH CAROLINA  
PHONE: (919) 825-3566  
EMAIL: REG36@CAPTIVEAIRE.COM

Corner Grill - Angier  
ANGIER, NC, 27501

DATE: 7/26/2023

DWG.#:  
6130024

DRAWN BY: REG 36

SCALE:  
1/2" = 1'-0"

MASTER DRAWING

SHEET NO.  
1

## Duct and Plenum Protection

The TANK Fire Suppression extinguishing system for duct and plenum coverage can be provided by independent fire suppression tanks and piping or integrated with the fire suppression tanks and piping used for protection of the appliances. Max of 5 nozzles per TANK for duct and plenum coverage only.

### Plenum Protection

The nozzle(s) (**page 7**), are used to protect plenum areas in both single bank and V-bank plenum configurations. The nozzle will protect up to a 4' wide x 10' long plenum section. For larger plenum areas, additional nozzles are added as required, with each nozzle protecting no more than a 4' wide by 10' long plenum section. Nozzles may be installed pointing in the same direction, and/or at opposite ends of the plenum, pointing toward each other. The nozzles must not be installed back-to-back when protecting plenum areas. When positioned at the end of the plenum, nozzles must be installed from 0 to 6" into plenum.

If the riser is not centered on the plenum, the plenum nozzle is placed on the side of the plenum closest to the riser.

The nozzle locations for plenum protection are shown in **Figure 17** and **Figure 18**.

**Figure 17 - Single Bank Filter Plenum**

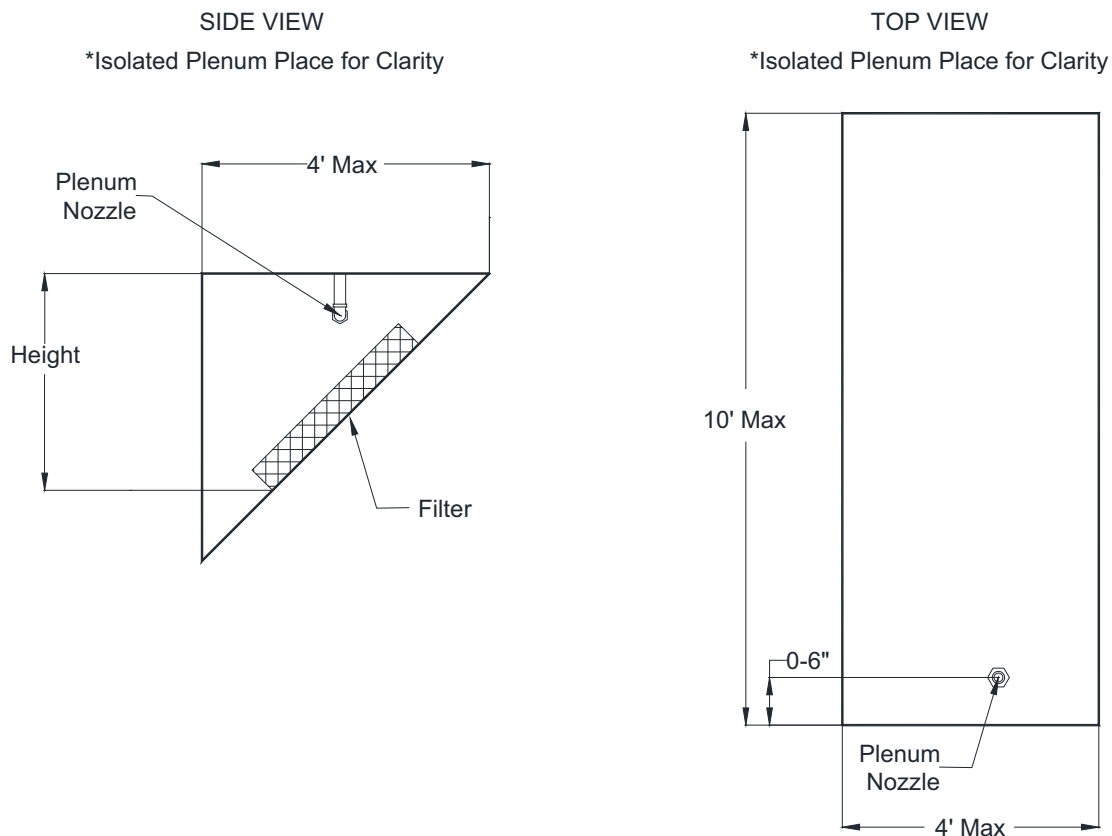

**Figure 18 - Dual V-Bank Filter Plenum**

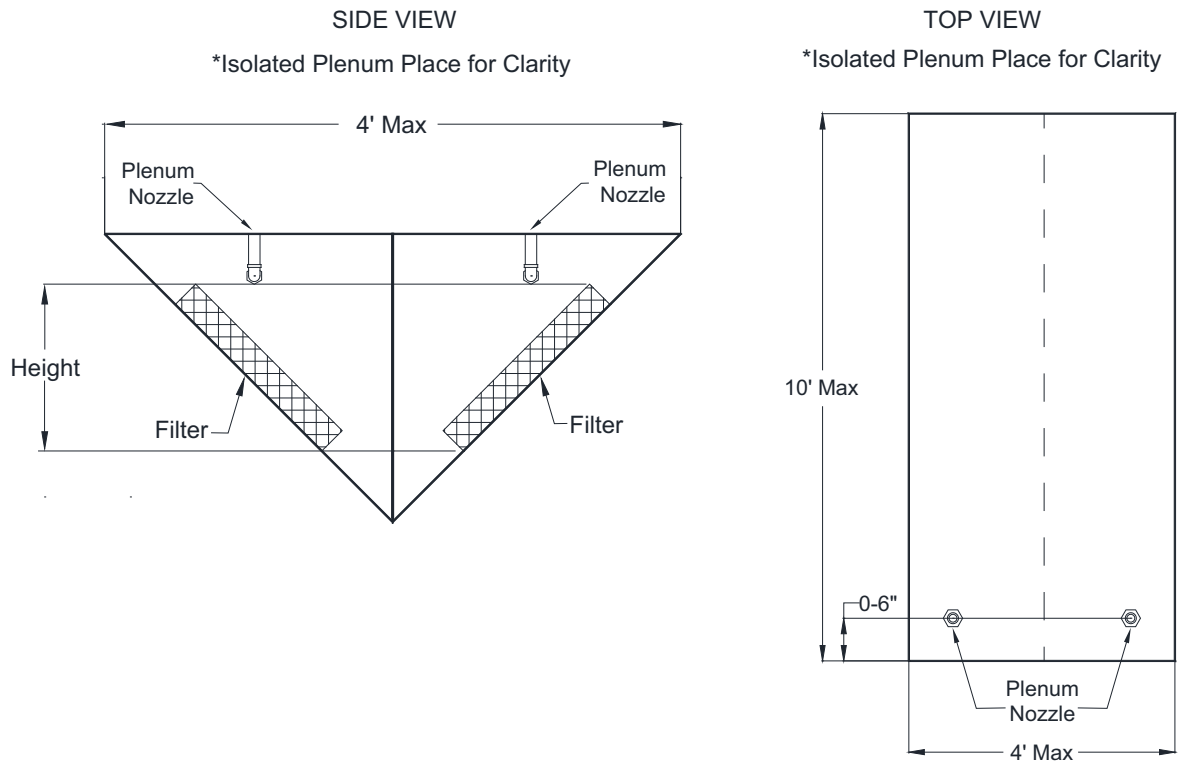

**Duct Protection**

The nozzle(s) (page 7) is used for the protection of exhaust ductwork and can protect any duct cross-section type (e.g. round, square, or rectangular). A sufficient quantity of nozzles must be provided to ensure that no single nozzle coverage exceeds 75" in perimeter.

A single nozzle will protect a duct up to 75" perimeter (22" nominal diameter) and unlimited length. Two nozzles are required for protection of 75-150" perimeter and unlimited length. A minimum of 3 nozzles is required for protection of ducts exceeding 150" perimeter (36" nominal diameter) and unlimited length.

When using multiple nozzles (modular protection), the coverage area for each nozzle must not exceed 75" perimeter.

**Figure 19 - Nozzle Duct Protection**

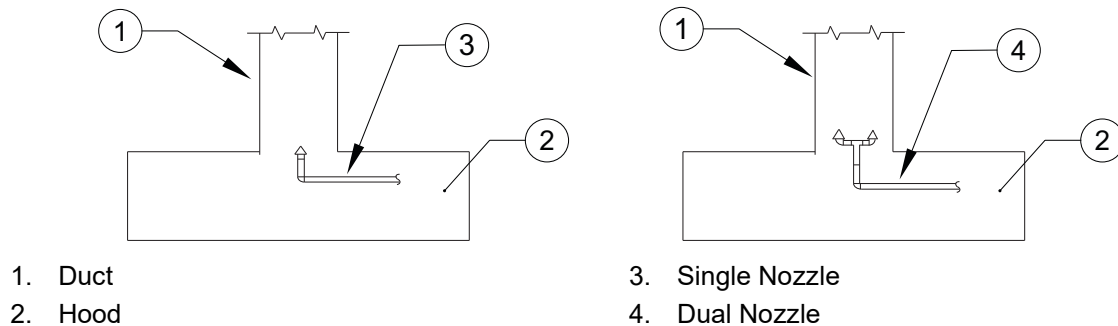

Nozzles must be installed from 0" to 6" into the protected area of the duct. When more than one nozzle is required (modular protection), each nozzle must be located at the center of its protected module area. Additional nozzles are not required for changes in direction\*. Duct obstructions and common ductwork must be protected in accordance with this manual, NFPA 17A and NFPA 96.

The nozzle location and aim for duct protection are shown in **Figure 20** and **Figure 21**.

\*When a change in direction occurs less than 6" from the duct entrance, the nozzle must be aimed as shown in **Figure 20** and **Figure 21**.

**Figure 20 - Single Nozzle Placement (0-75" Perimeter Duct)**

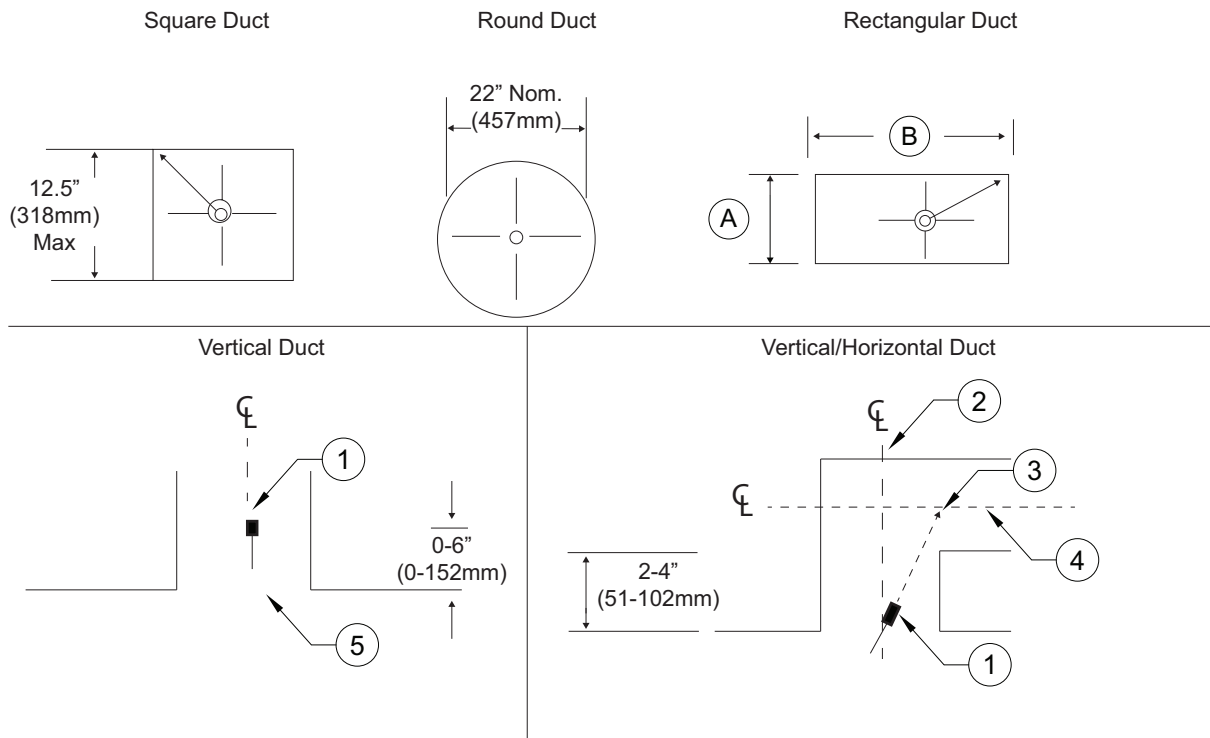

1. Nozzle
2. Horizontal Duct Centerline (CL)
3. Aim Point
4. Vertical Duct Centerline (CL)
5. Duct Entrance

- A. Rectangular Duct Width
- B. Rectangular Duct Length

- Duct perimeter up to and including 75" (1270mm).
- To determine the perimeter:  $2(A) + 2(B) = 75"$  (1905 mm).

**Figure 21 - Dual Nozzle Placement (75-150" Perimeter Duct)**

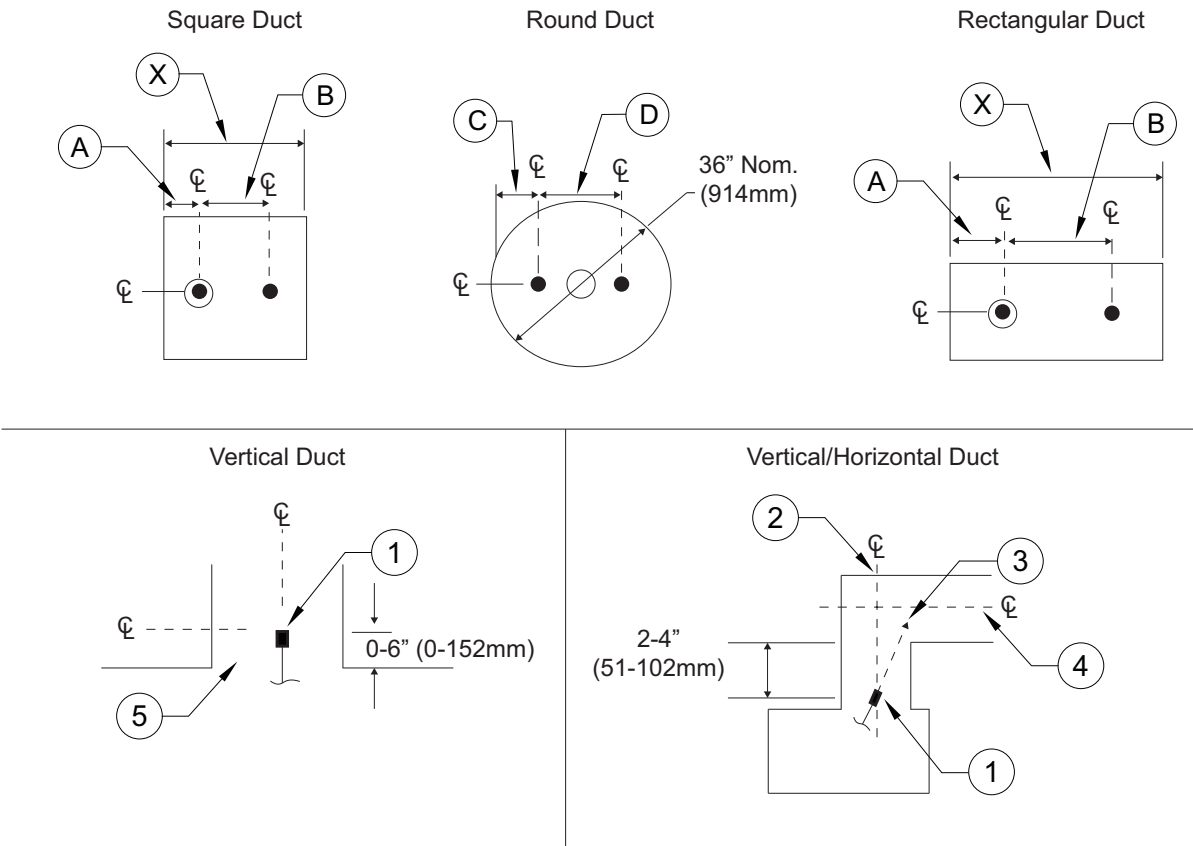

1. Nozzle
2. Vertical Duct Centerline (CL)
3. Aim Point
4. Horizontal Duct Centerline (CL)
5. Duct Entrance

- A. 1/4 of dimension X
- B. 1/2 of dimension X
- C. 1/4 of Duct Diameter
- D. 1/2 of Duct Diameter

## Ventilation Exhaust and Dampers

The TANK Fire Suppression extinguishing system can be used with the exhaust fan either on or off when the system is discharged. It is recommended that the exhaust fan remain on at the time of discharge to aid in the removal of smoke, gases, and other airborne materials from the hazard area in the event of a fire. If the Authority Having Jurisdiction (AHJ) requires that the damper closes in the event of a fire system discharge, the system designer shall provide for protection downstream of the damper in compliance with NFPA 96, local codes, and/or as approved by the AHJ.

## Electrostatic Precipitators (ESP)

An Electrostatic Precipitator (ESP) is designed to remove smoke and other airborne contaminants from the air flowing through the exhaust ductwork as a means of pollution control. Exhaust ductwork using ESPs requires Overlapping Male nozzle(s) (p/n OL-M [previously 3070-3/8HH-10-SS]) upstream, before the ESP. Distribution piping to the nozzles must not interfere with the function of the ESP unit.

A Pollution Control Unit (PCU) and/or Electrostatic Precipitator (ESP) covered with this fire system can utilize up to 12 nozzles per tank.

## Appliance Protection

The TANK Fire Suppression system utilizes both overlapping and dedicated nozzle appliance coverage, depending on the type of cooking appliance(s) requiring protection. For dedicated and overlapping nozzle information, refer to “**Nozzles**” on page 7.

Overlapping appliance coverage allows a given area under the hood, defined as the hazard zone, to be protected by overlapping nozzles. Nozzles are evenly spaced at the same height and alignment (front-to-back) relative to the hazard zone.

Dedicated appliance protection utilizes a nozzle, or nozzles, for protection of an individual appliance.

Overlapping, dedicated appliance, plenum, and duct protection may be incorporated in a single pipe network on the TANK Fire Suppression extinguishing system, as long as the number of nozzles per tank does not exceed five.

The following sections detail the different nozzle coverage and placement parameters for overlapping and dedicated nozzle appliance protection methodologies. Double row coverage is allowed for TANK.

### Overlapping Appliance Protection

A single hazard zone utilizing overlapping coverage is 30” deep, by the total length of the cooking surface of the protected appliances. The cooking surfaces of all appliances protected by overlapping nozzles must be located within the defined hazard zones. Cooking appliances eligible for overlapping protection are outlined in **Table 3 on page 19**. The lowest and highest cooking surfaces will determine the height of the fire suppression nozzles. All overlapping nozzles must be mounted at the same height in a single hazard zone.

For applications where overlapping protection cannot be used, such as an upright boiler, dedicated appliance protection must be used.

**Figure 22 - Overlapping Protection Option**

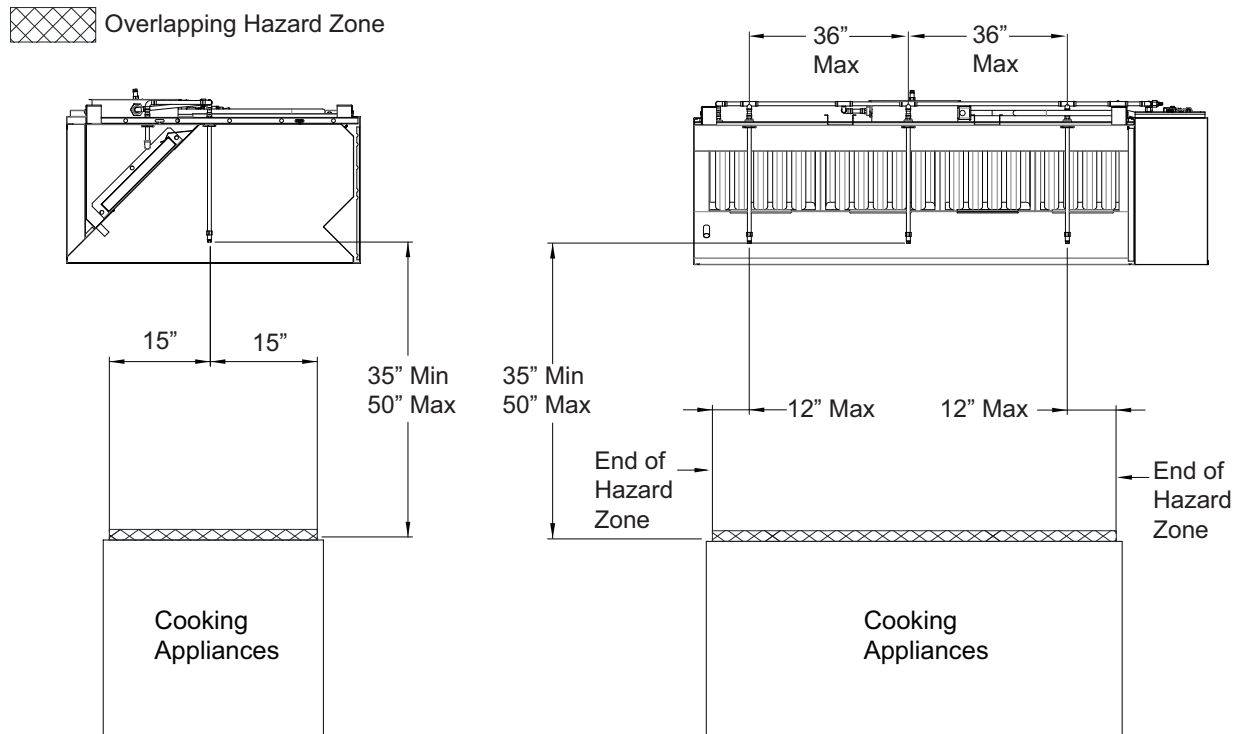

## Appliance Coverage

**Table 3** illustrates the maximum permitted cooking surface dimensions of each appliance that can be protected within a single overlapping zone. It is important to note that the cooking surface (area requiring protection) is different than the total appliance size.

**Table 3 - Standard Overlapping Protection 5 nozzles per tank (20 flow points),  
36" max nozzle spacing**

Hazard	Fuel Source	Maximum Depth of Cooking Surfaces	Maximum Length of Cooking Surfaces	Maximum Height of Fuel
Multi Vat Fryer <sup>(3)</sup> (with or w/o Drip-board)	Gas or Electric	30" deep	Unlimited	N/A
Split Vat Fryer, <sup>(3)</sup> (with or w/o Drip-board)	Gas or Electric	30" deep	Unlimited	N/A
Tilt Skillet	Gas or Electric	30" deep	Unlimited	N/A
Griddle	Gas or Electric	30" deep	Unlimited	N/A
Gas/Electric Radiant Charbroiler	Gas or Electric	30" deep	Unlimited	N/A
Upright Charbroiler/ Salamander, Chain*	Gas or Electric	30" deep	Unlimited	N/A
Appliance w/o Shelf/Obstruction*	Gas or Electric	30" deep	Unlimited	N/A
Range w/o Shelf/Obstruction*	Gas or Electric	30" deep	Unlimited	N/A
Wok	Gas or Electric	11-24" diameter	11-24" diameter	6-3/4" deep

### Notes:

1. All dimensions shown are based on overlapping protection.
2. All dimensions and areas shown reference the cooking surface of the appliance, which is typically smaller than the outside dimensions of the appliance itself.
3. For multi-vat fryers, no single fryer module (vat & drip board) can exceed the above limitations.
4. Protection for tilt skillets and braising pans are to be based on the coverage parameters provided for fryer protection. Tilt skillets should be placed at the back of the hazard zone. Tilt skillet coverage must not interfere with the edge of the nozzle discharge pattern.
5. All appliance hazard surfaces must be located within the hazard zone.
6. Smaller appliances can be positioned anywhere in the zone (e.g., moved left, right, forward, or backward, provided the cooking hazard does not extend beyond the perimeter of the zone).
7. When the depth of the appliance exceeds maximum cooking hazard dimensions, a second row of nozzle coverage should be added.
8. Deep Fat/Industrial Fryer/Tilt Skillets over 14" wide and up to 34" max depth will be overlapping with 4 nozzles per tank, 30" max spacing. Max oil capacity: 24.75 gallons.
9. Nozzle height(s) for fryers should be taken from the fryer's minimum level indicator.

**Figure 22** illustrates the placement of nozzles for TANK Fire Suppression overlapping protection.

Appliances denoted with an (\*) require dedicated coverage. Refer to **"Upright Broiler/Salamander Protection"** on page 25 and **"Appliance with Shelf"** on page 26 for details.

# TANK

## CERTIFICATE OF COMPLETION

CaptiveAire extends this certificate of attendance to

**Joshua McLamb**

for completing the

### ELECTRIC WET CHEMICAL TRAINING

Commercial Kitchen Fire Suppression System || Listed to UL Standard 300

TRAINING DATE

July 9, 2020

TRAINING LOCATION

Raleigh, NC

# CAPTIVEAIRE



ROBERT LUDDY  
PRESIDENT / CAPTIVEAIRE SYSTEMS, INC.